

1. GENERAL

The SIG60 Evaluation board allows quick testing of the SIG60 IC device in a network of SIG60 and SIG61 devices. The evaluation board has a host interface to user's UART port. This evaluation board will serve the user as a communication reference design when compared to its own built SIG60 application board. Multiple SIG60 boards can communicate over a DC power line using the UART/LIN interface. Network example is presented in Figure 1.1.

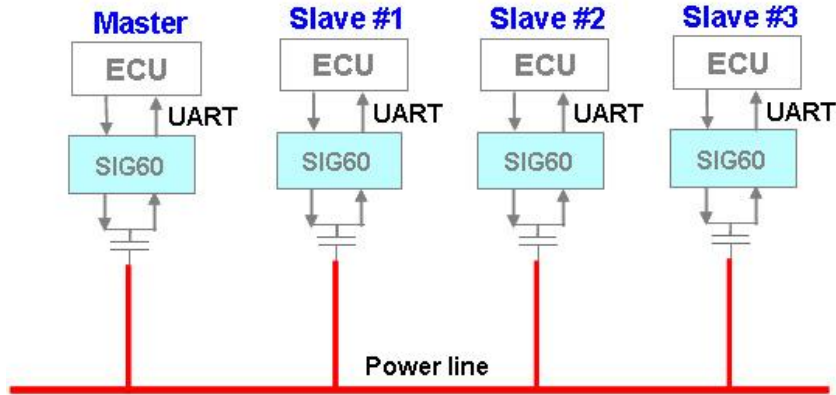

Figure 1.1 - System configuration example

2. SIG60 Board Description

2 .1. Block Diagram Description

The Module contains all the required hardware for device operation such as a line protection network, ceramic filters, and a power supply. The board performs an asynchronous UART protocol over DC power lines at data rates of up to 57.6Kbps. Operation at 115.2Kbps requires dedicated filters. The SIG60 may also be used as a new physical layer to the LIN protocol. The Module can be connected directly to a host (Micro controller with UART port or a PC) through its JP1 I/O connector. The EVB block diagram is described in Figure 2.1

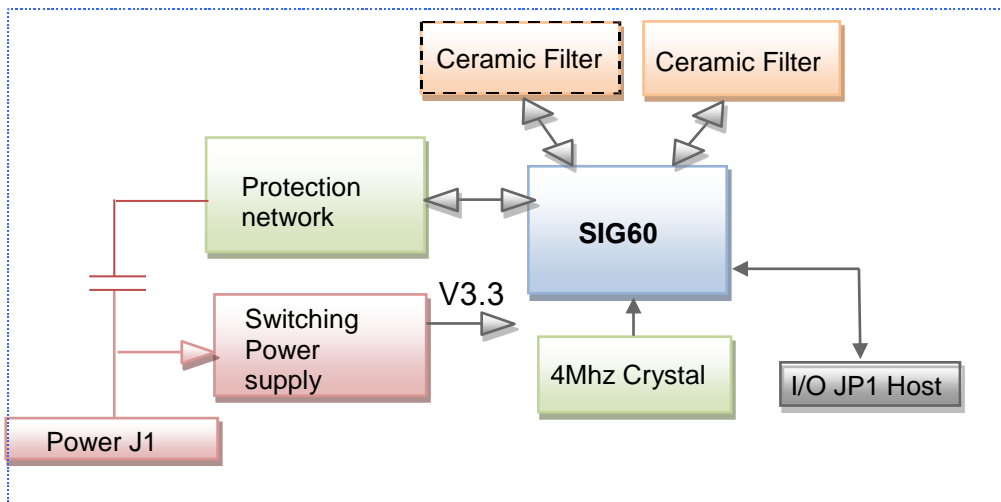

Figure 2.1 - SIG60 Board block diagram

The received data signal from the DC line passes through a protection network into the RxIn input pin to an Rx amplifier. The amplified signal passes via F0B or F1B pins to an external ceramic filter and back into RxP input. The SIG60 decodes the data and output it to HDO pin as an asynchronous bit stream.

On the transmitter side, the host sends UART data to the SIG60 via HDI pin. The asynchronous data is protected against errors and modulated inside the SIG60. The DTXO pin outputs the digitally modulated signal to the ceramic filter for shaping. The shaped signal enters the SIG60 via F0B or F1B pins into an output amplifier. The modulated data on TxO pin drives the DC line via the protection network. To connect HDI and HDO signals to a PC, additional RS232 or USB interface is required.

The switching power supply provides the 3.3V voltage required for the SIG60 operation. The power supply operates in a wide input voltage range between 10V and 36V. The module current consumption is in the range of 30mA depends on supply voltage.

The SIG60 internal registers, as described in the SIG60's datasheet, determine the operating communication frequency and bit rates. HDC signal is used for accessing the registers.

2 .2. Hardware features:

- Noise robust DC Power Line Communication
- UART serial interface
- Selectable data rates 9.6Kbps to 115.2Kbps
- One or two selectable operating frequencies
- Use of low cost ceramic filter(s)
- 10V to 36V operation using switching power supply
- Indication LEDs
- Small size board (40mm*27mm)

Connectors:

JP1 – Host interface, configuration pins and Test I/O connector.

JP2 – DC line connector and test points.

Display LEDs:

Tx LED - Indicates transmission.

Rx LED - Data output, indicates reception.

F1 LED - Indicates the selected channel (On=F1)

2 .3. Mechanical Data

The mechanical dimensions are shown in Figure 2.2.

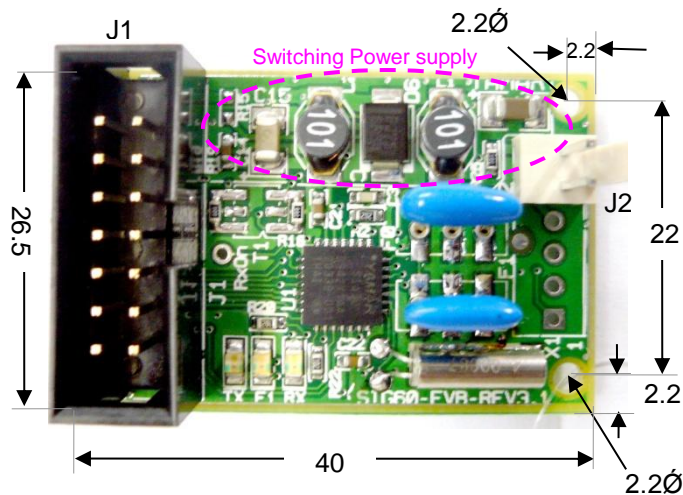

Figure 2.2 – SIG60 Module dimensions