

Understatement!



Performax® –
maximum output at minimum size

Dynamic. Robust. Powerful.

Performax®
Performax® Plus
HRL radial load stage

Performax® – the top-notch planetary gearhead concept

Performax® is an innovative powerful planetary gearhead concept, patent pending. Advanced in design, Performax® gearheads are impressive by virtue of outstanding power density, ultimate smoothness and unique reduction ranges. This opens up unlimited application options for modern drive requirements.

Performax® is a shining example of outstanding drive solutions and of the results of our more than 50 years of experience working in the drive technology sector. Increased efficiency, quality and lifetime are particularly important to us by way of ensuring that your investment pays off. Maximum energy efficiency goes without saying.

Performax® – the powerful basis

The Performax® series has been a success story for years. The design idea behind it makes it ideal for innumerable applications. Principally, it is this gearhead's maximum output power at minimum space requirement that makes it possible to use single-stage gearheads where the market can normally only provide two-stage gearheads.

With gear reductions of up to 17:1 in a single stage, Performax® impressively confirms its inimitability. Perfect balance of gearhead reduction and motor output makes Performax® gear-motors unbeatable.

A modular concept with utmost performance in mind.



Performax® – efficiently meeting the most stringent requirements

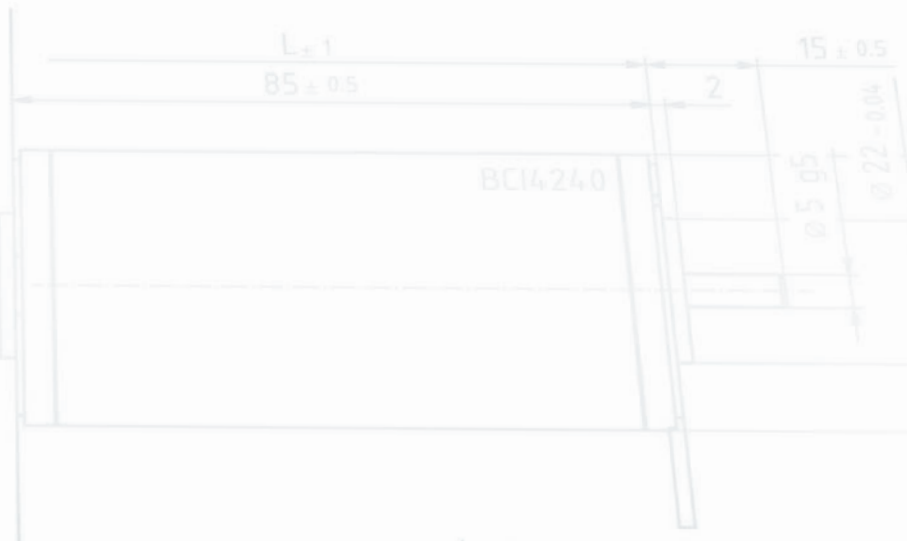

Performax® – more than just a gearhead

Continuous consistent further development of our efficient gearheads is what drives us. The results are perfected products, additional product elements and performance-oriented design variants that confirm our position as a leader in technology and a provider of almost unlimited application options for the user.



Performax® Plus – the robust variant

Difficult conditions and uses are child's play to power package Performax® Plus. This extremely powerful gearhead demonstrates its advantages in situations where ultimate output power is demanded.

Up to 100 percent increased max. transferable torque is achieved by means of large tooth widths in the input stage, the casing and the case hardened steel concave toothing in the output stage. This casing is also a guarantee for maximum impact resistance.

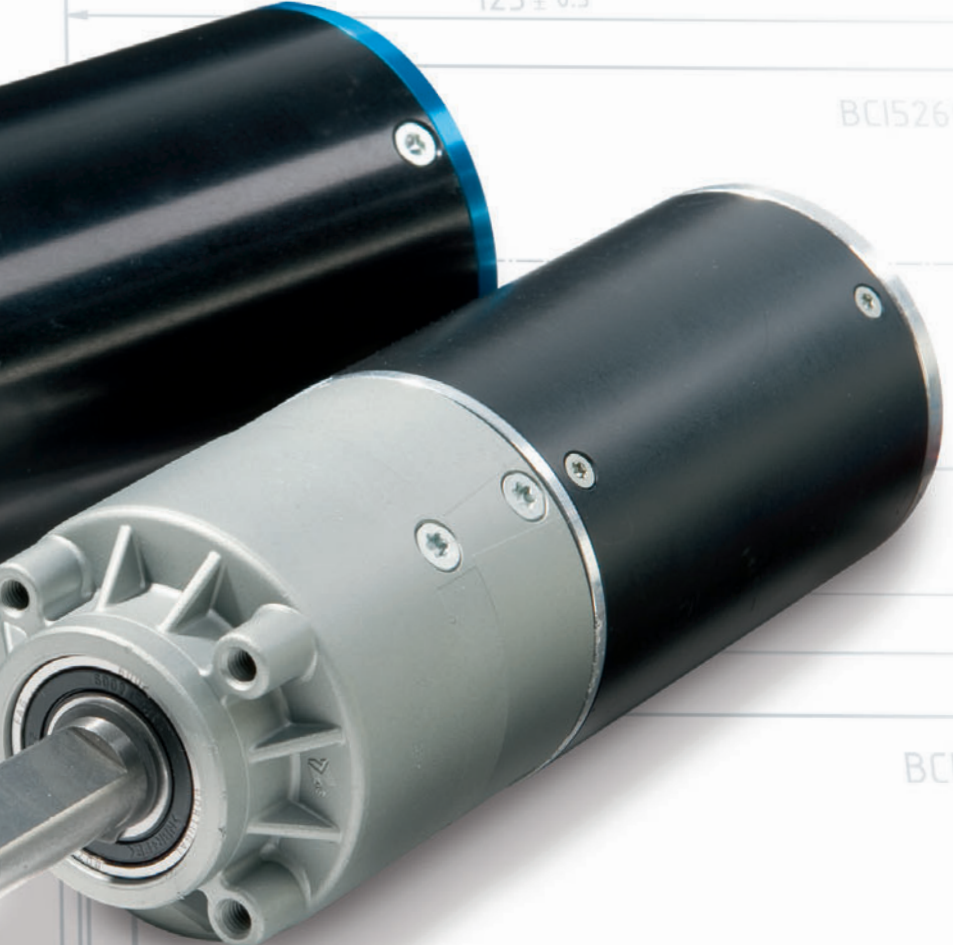

HRL radial load stage – powerful transmission of high radial loads

Our answer to extra high radial loads is our HRL (High Radial Load) radial load stage. By mounting both sides of the carrier on bearings the high radial loads of the drive shaft are easily coped with. This special design lends the gearhead outstanding performance capabilities. HRL is possible for both Performax® and Performax® Plus of whatever sizes and performance levels.

**We provide the best drive.
Out of principle.**

Performax® – impressive, stage for stage

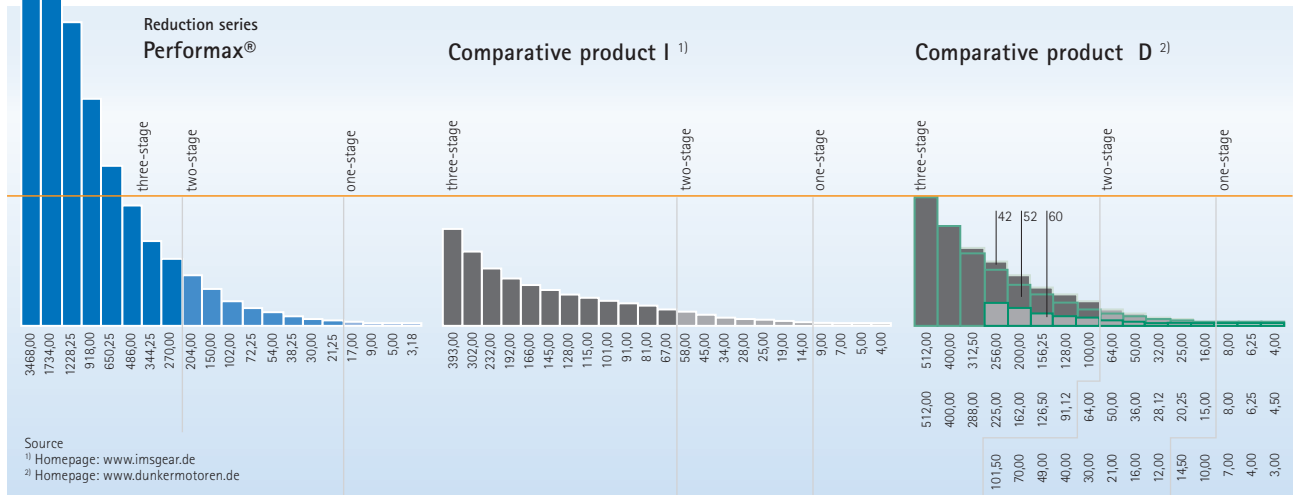

Unique density of reduction – max. output

The design principle is impressive from every point of view. As regards number of stages and installation space, Performax®, with the same number of gear stages, has the greatest density of reduction by a long way.

With gear reductions of 17 : 1 in a single stage, 204 : 1 in two stages and 3,468 : 1 in three stages, we convincingly keep our promise of "maximum performance at

minimum size". Single stage gearheads of better efficiency are still possible in situations where a two-stage competitor product is necessary. The gear reductions are harmoniously staged and are intentionally finely arranged in the smaller gear reductions range

The intelligent feature of the design is the radial screw joint for the individual casing elements that makes it possible to obtain maximum usable diameter for concave toothing. Our many years of experience

and leading position in toothing technology enables us to produce motor shafts with only three teeth. Connection to all normal DC, AC and EC motors is possible and available as standard. Another feature of this outstanding drive technology is helical-toothed plastic gearwheels in the first stage, for minimising sound emissions, and case hardened steel planetary wheels on needle bearings in the output stage.

Outstanding smoothness expertly achieved

Readings taken by a certified noise level testing laboratory confirm the outstanding smoothness of the Performax® gearheads. This is where optimum gear reduction stages plus the use of plastic for toothing in the first stage pay off.

The sound power level of an idling two-stage Performax® 52 is below 48.2 dB(A). The sound power level of a single stage gearhead with higher output revs is almost the same as that of the two-stage version.

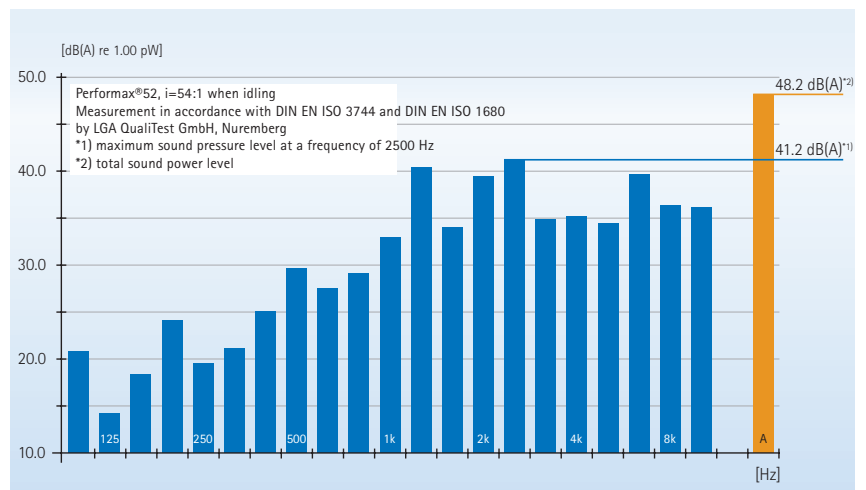

Possible material combinations for the Performax® standard modular range

	Plastic (POM)	Brass	Steel	Hardened steel	Stainless steel	Die-cast zinc
Sun wheel			● ◆	● ◆		
Planetary wheel	● ◆	● ◆	● ◆	● ◆		
Hollow wheel	● ◆		◆	◆	◆	
Sun wheel			● ◆	● ◆		
Planetary wheel	● ◆	● ◆	● ◆	● ◆		
Hollow wheel	● ◆					
Sun wheel			● ◆	● ◆		
Planetary wheel	● ◆	● ◆	● ◆	● ◆		
Hollow wheel	● ◆		◆	◆	◆	●
Drive shaft			● ◆	● ◆	● ◆	●

■ Standard material ○ Performax®
■ Special material ◇ Performax® Plus

Material combinations – based on requirements

We design your gearhead solutions expressly to your particular requirements and based on our unique standard modular system principle. Extra to the materials used for standard models, alternative materials are available for sun wheels, planetary wheels and hollow wheels as well as for drive shafts, depending on how we are to further optimise your custom solution in terms of smoothness, torque and output.

Connection options – optimised for best power transference

Normally, Performax® drives are supplied as complete units consisting of motor and gearhead. The sun wheel toothing in the first stage (pinion) is directly milled into the motor shaft. This provides ideal true running characteristics plus compactness.

Alternatively, motors can be connected using bonded pinions or clamp pinions.

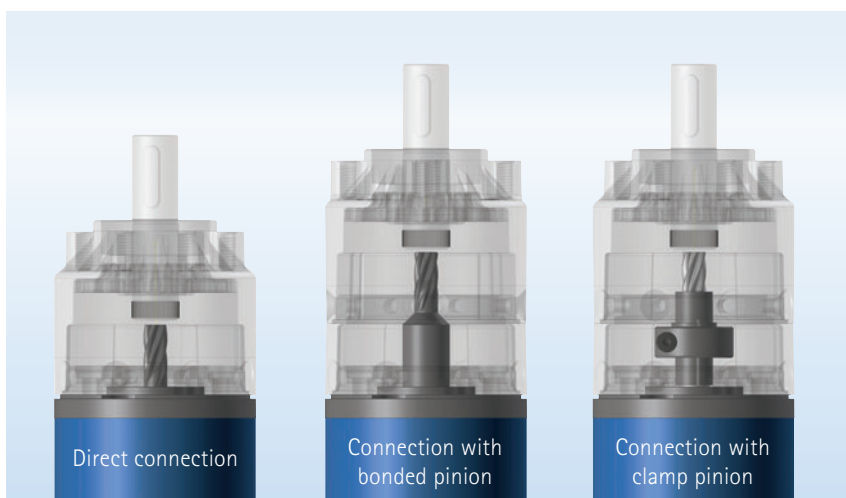

Output shaft – conceived for custom applications

As standard, Performax® gearheads transfer torque with either feather key connections or face connections. The use of case hardened steel or tempered steel makes both versions particularly wearproof. Of course, we also produce special output shafts with double surfaces, shoulders, front or circumferential side (tapped) holes, recesses or serrations, for instance. With Performax® Plus you also have the option of having input on the pitch circle, centring collar and casing shape.

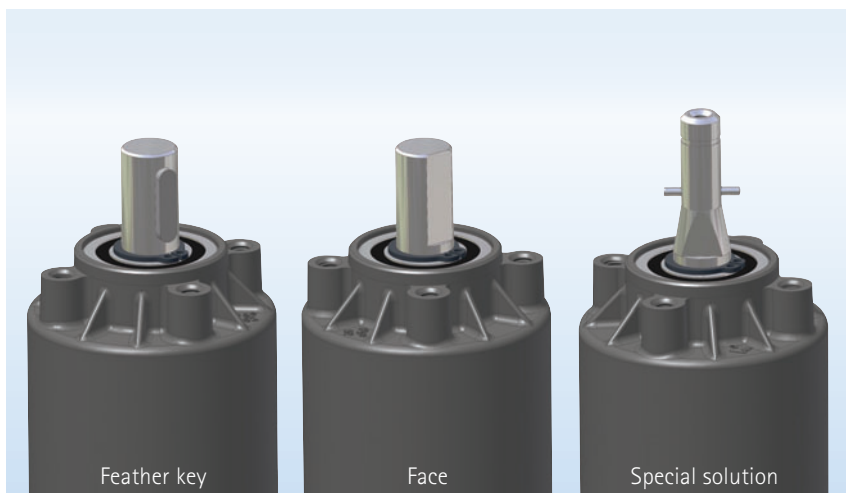

Performax® Plus – the power package for difficult conditions

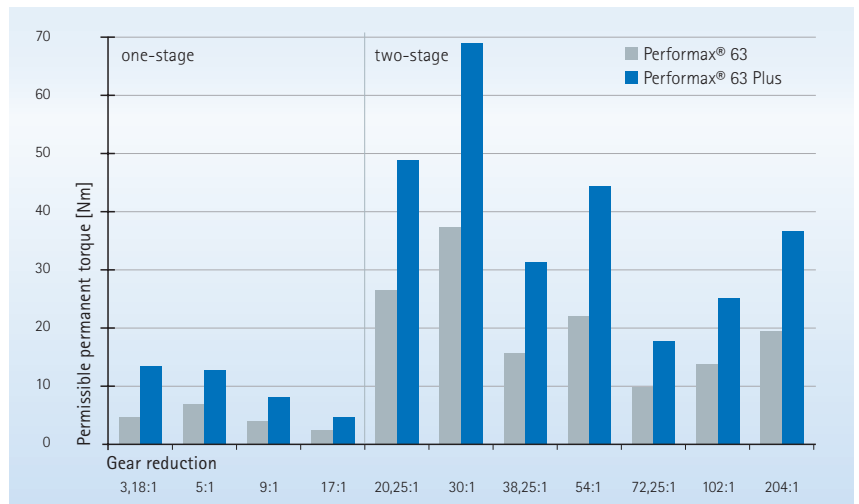

Performax® Plus – impressive performance

Everywhere where difficult conditions hold sway and robust construction as well as high output performance is required, Performax® Plus can demonstrate its special strengths.

Extra power transmission results from toothing in the input stage being up to 100 percent larger and from increased

strength obtained from concave toothing in hardened steel. Another advantage of the steel casing is its higher impact resistance.

Using brushless electronically commutated motors plus optimum configuration and appropriate power density, we can permit very high input torques up to 1 Nm.



Performax® Plus and HRL – an unbeatable duo

Combining Performax® Plus with the HRL radial load stage produces a drive power package that has no equal.

A powerful gearhead – designed for tough uses

HRL radial load stage – ready for any maximum radial load

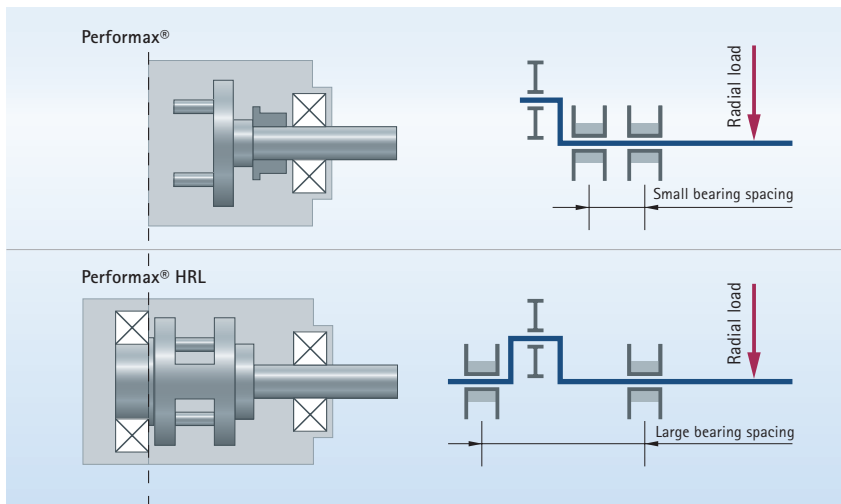
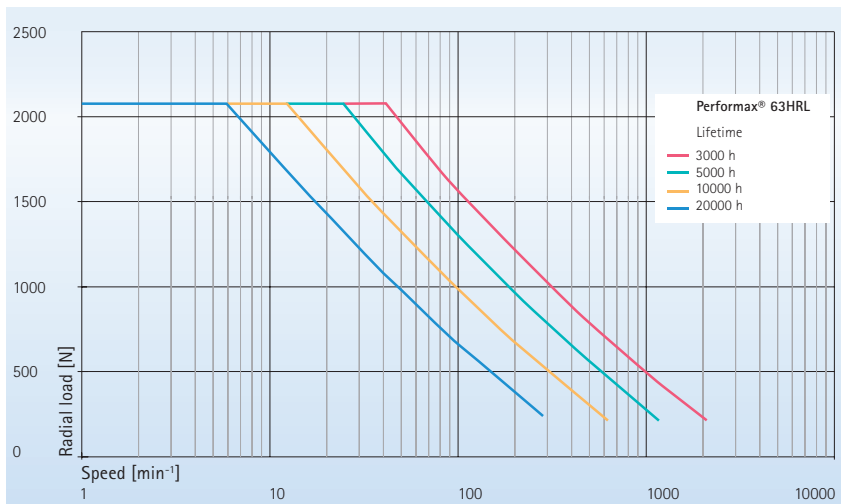

HRL radial load stage – defining performance limits new

A special carrier enables bearing-mountings both sides and the planetary wheel needles to be precisely run. In turn, the carrier is properly supported by an efficient deep groove ball bearing. The resulting large bearing spacing is responsible for the significant increase in transferrable radial loads.

This optimum union of carrier and output shaft is able to guarantee very high torque values. The results are best possible rotation characteristics as well as superb smoothness – even given the highest radial loads.

Performax® in detail

- First stage: Helical toothed planetary wheels and hollow wheel made of plastic for more even engagement conditions (more overlap) and good damping characteristics (minimising noise)
- Intermediate stage: With plastic hollow wheel for reducing noise, helical toothed planetary wheels made of a copper-zinc alloy for increased torque load, planetary wheels with pressed-in needle bearings for reducing bearing friction
- Output stage: Die cast zinc casing designed entirely for performance
- Cast spur toothing
- Drives and planetary wheels made of case hardened steel
- Planetary wheels on needle bearings

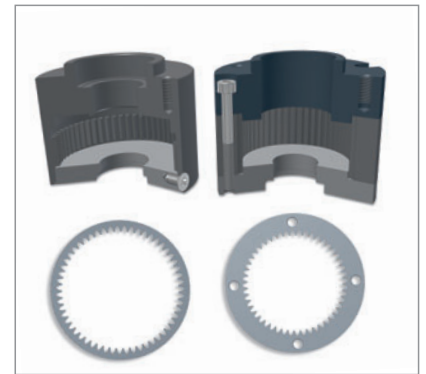

Maximum useable diameter achieved with radial screw joint, input torque up to 1 Nm possible

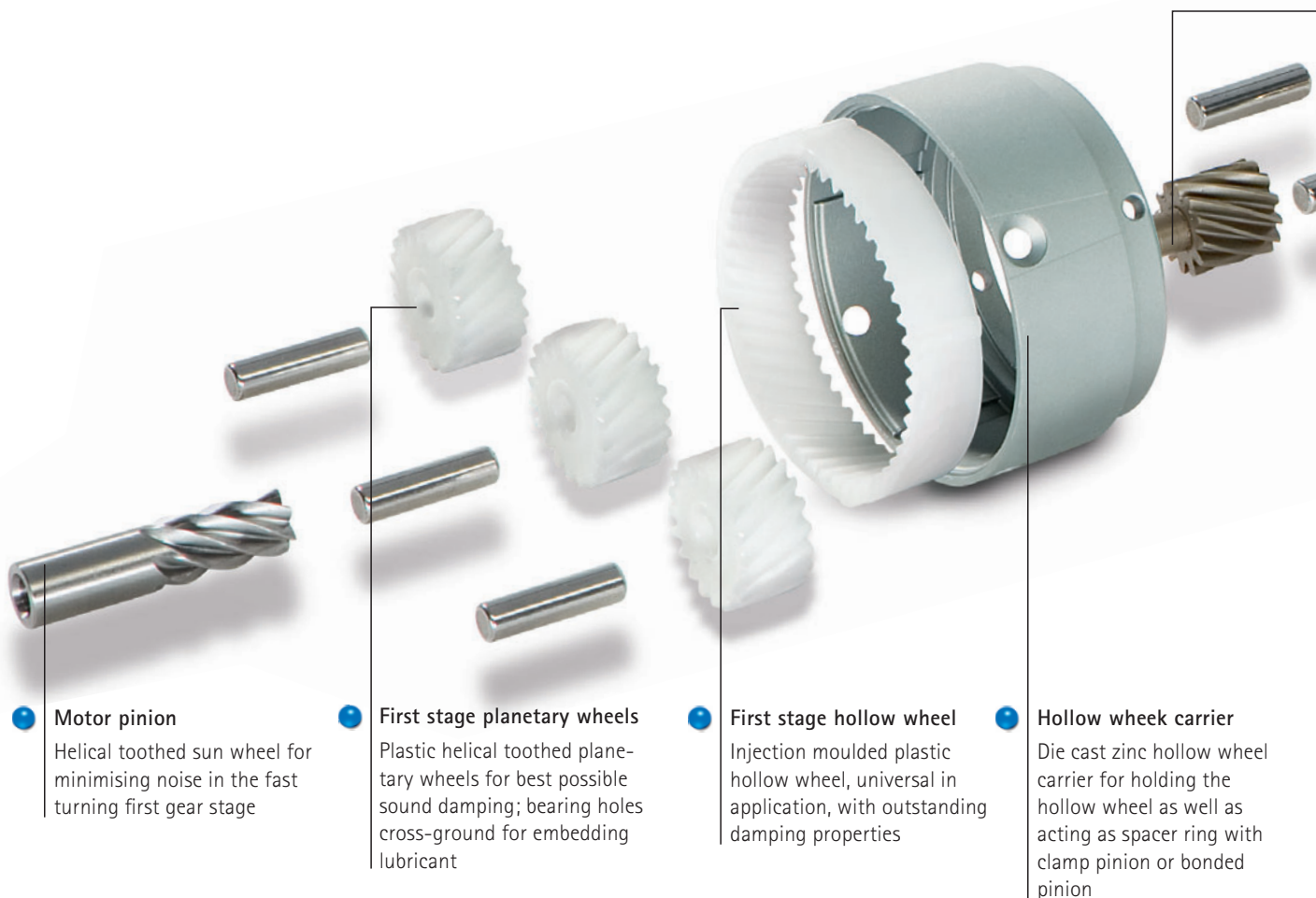

Motor pinion
Helical toothed sun wheel for minimising noise in the fast turning first gear stage

First stage planetary wheels
Plastic helical toothed planetary wheels for best possible sound damping; bearing holes cross-ground for embedding lubricant

First stage hollow wheel
Injection moulded plastic hollow wheel, universal in application, with outstanding damping properties

Hollow wheel carrier
Die cast zinc hollow wheel carrier for holding the hollow wheel as well as acting as spacer ring with clamp pinion or bonded pinion

● **Second stage drive**
Second stage drive (sun wheel) made of case hardened steel

● **Second stage planetary wheels**
Improved power transfer by means of helical toothed planetary wheels made of a copper-zinc alloy for extreme smoothness and increased strength

● **Third stage drive**
Third stage case hardened drive (sun wheel) – preventing axial loads by using spur toothing

● **Needle bushes and needle bearings**
Long-lasting and wear resistant Planetary wheels on rolling bearings and hardened needle bearings

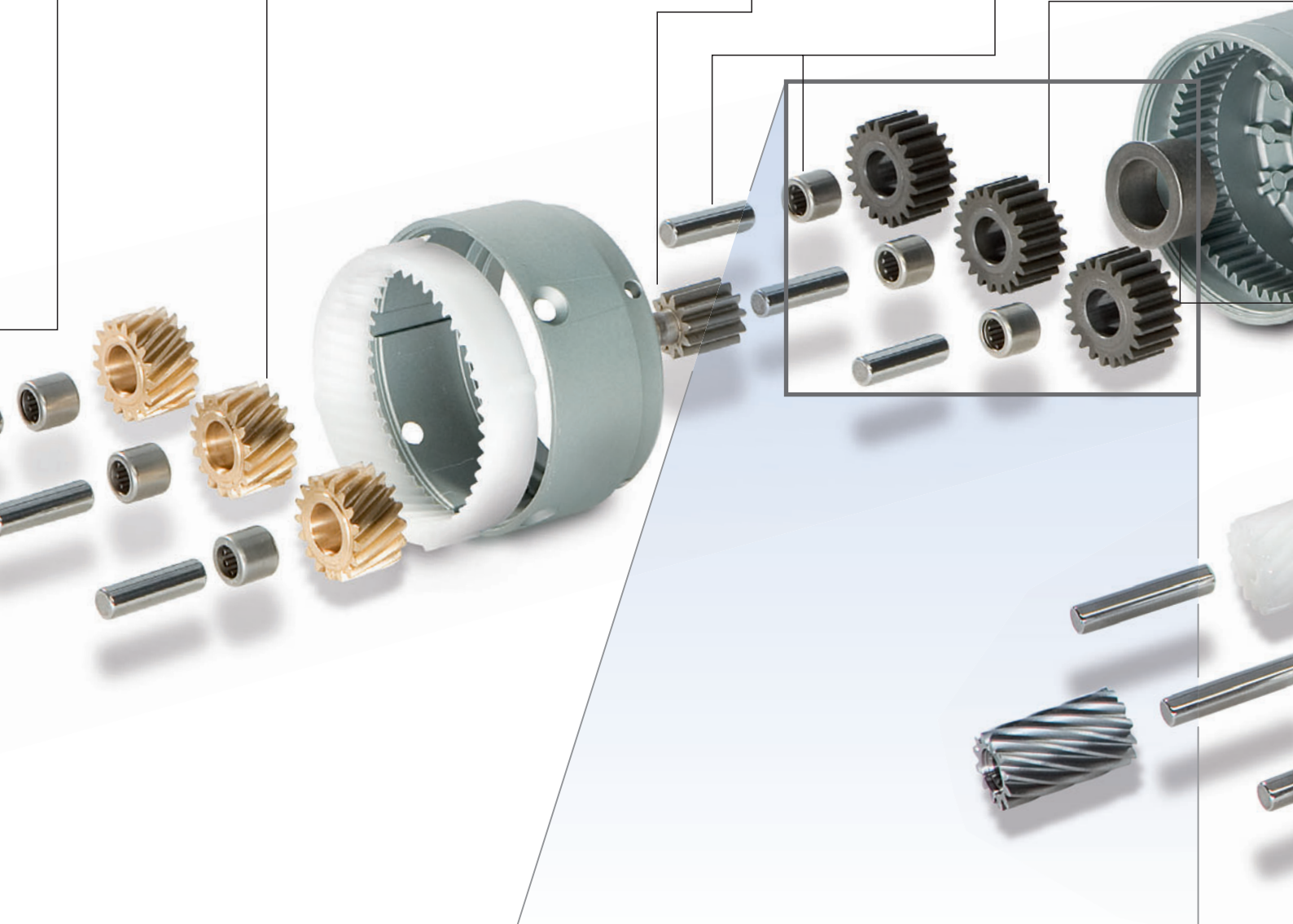

Performax® HRL in detail

- torsionally stiff carrier made of die cast zinc
- needle planetary axles supported both sides
- carrier run on deep groove ball bearing both input and output sides
- high torque transfer and optimum rotation characteristics achieved by recasting the knurled output shaft

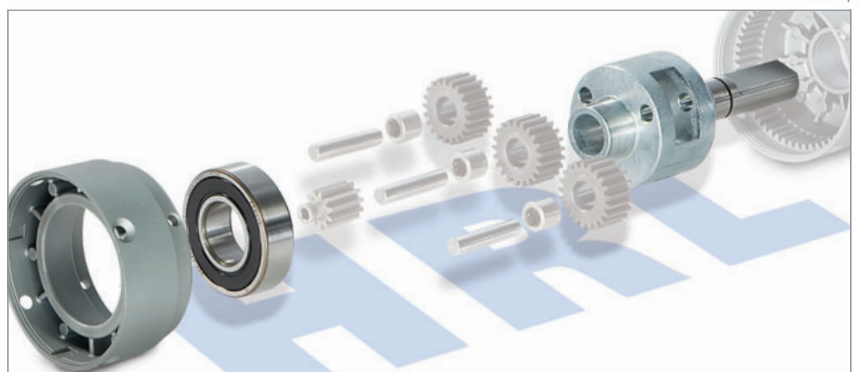

High-performance components for extra high radial loads

● **Third stage planetary wheels**
Spur toothed planetary wheels made of case hardened steel for transferring high loads

● **Planetary carrier**
Optimised die cast zinc carrier with cast internal tothing: sound damping achieved by high ductility of the material

● **Output shaft**
Hardened and polished output shaft as standard, optionally with feather key slot or face; diameter tolerance: h7

● **Slide bearing / ball bearing**
Long lasting sealed deep groove ball bearing and slide bearing for taking the radial and axial loads

● **Widened second stage**
Markedly wider (up to 100 %) for increased torque transfer

● **Widened first stage**
Markedly wider (up to 100 %) for increased torque transfer

Performax® Plus in detail

- Transfers up to 100 % more torque via greater tothing widths in fist stage
- Double bearing bushings and greater tothing widths in the intermediate stage
- Carrier made of hardened steel with spur tothing in the output stage

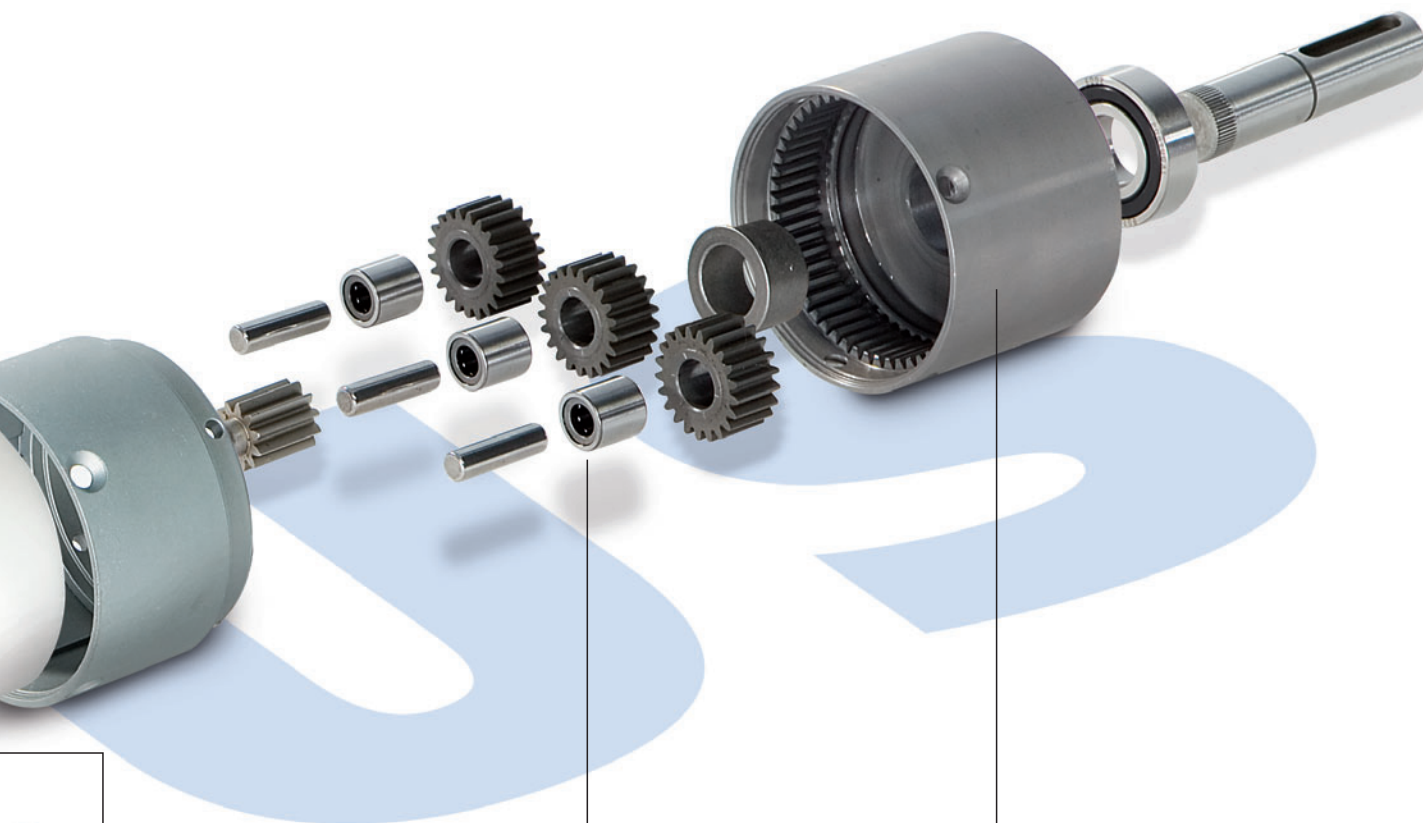

● **Double bearing bushes**
Improved running characteristics and more even load distribution

● **Strengthened bearing in output stage**
Increased load transfer achieved by replacing the bearing bushes with needle bearings

● **Carrier made of hardened steel in the output stage**
Higher torque achieved by increasing the strength of the toothing

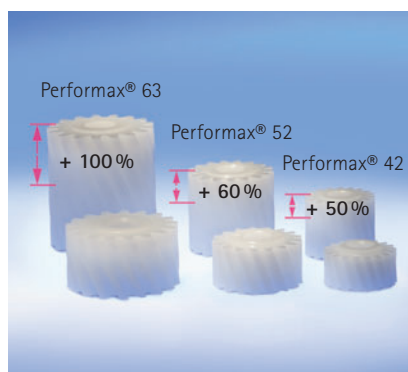

More torque from greater toothing widths

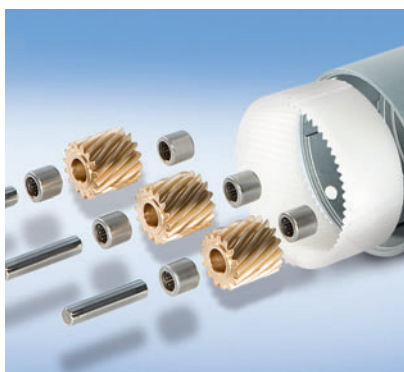

Additional optimisation of characteristics achieved with double bearing bushes



Made for hard work: hardened steel carrier

Performax® Plus

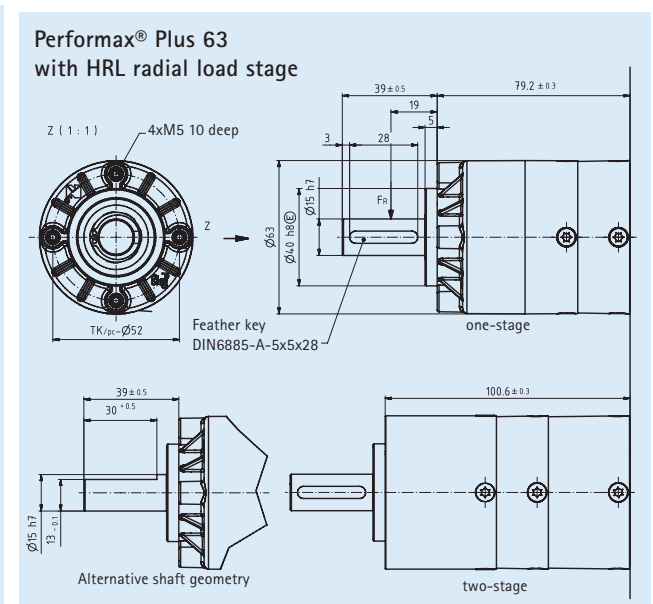
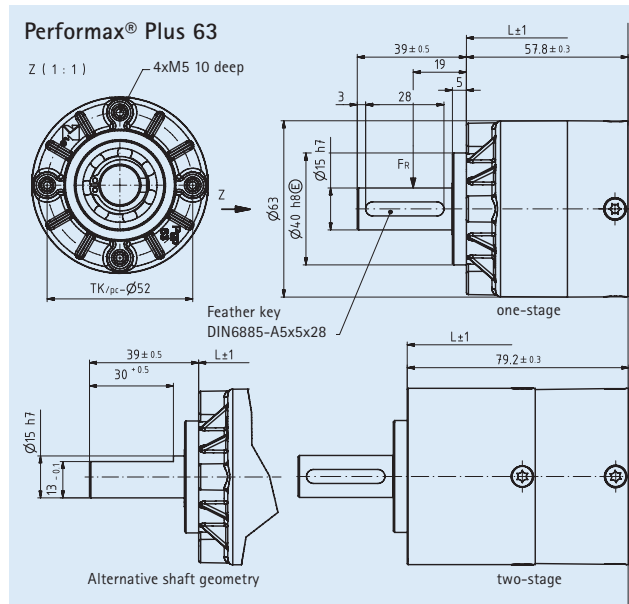
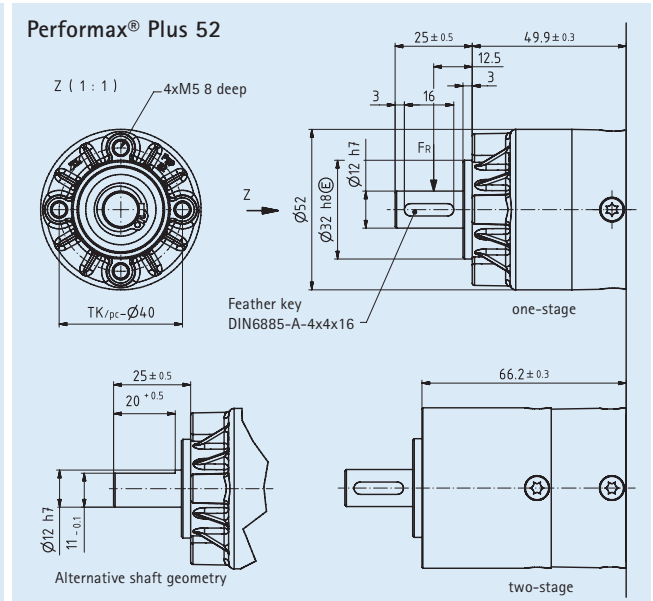
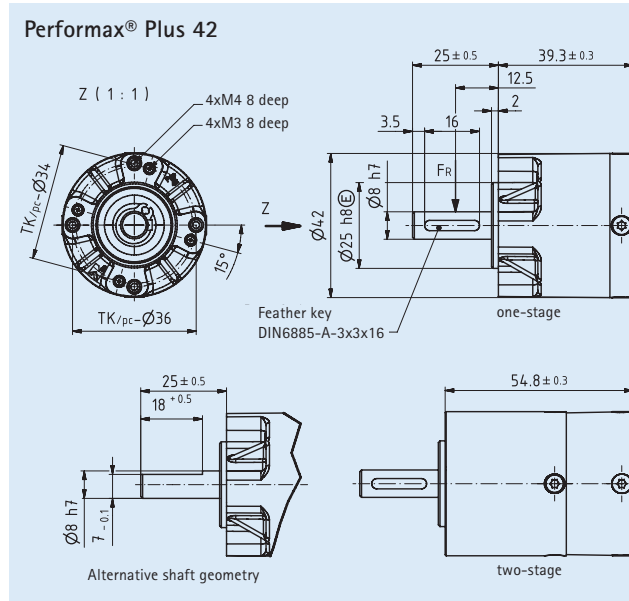

Available sizes	32	42	52	63
Performax®	●	●	●	●
Performax® Plus	○	●	●	●
HRL radial load stage	○	○	○	●

● Standard sizes available
○ Custom sizes possible

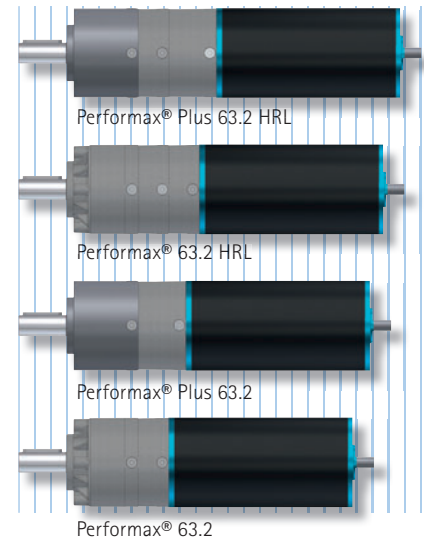

Performax® – top performance from the smallest of spaces

The Performax® series provides a large power spectrum in various different sizes. The impressive feature of the sophisticated design is the slight length differences

between the various types. Moreover, the same connection dimensions and geometries throughout guarantee optimum compatibility.

Performax® – performance that sets standards

Performax®

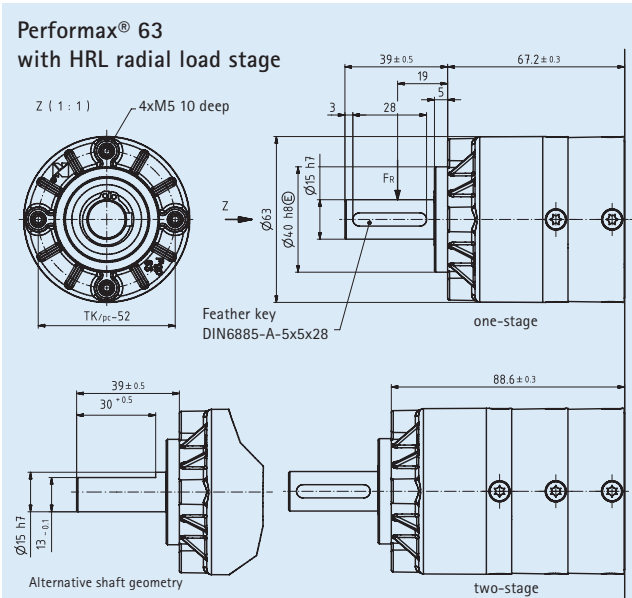
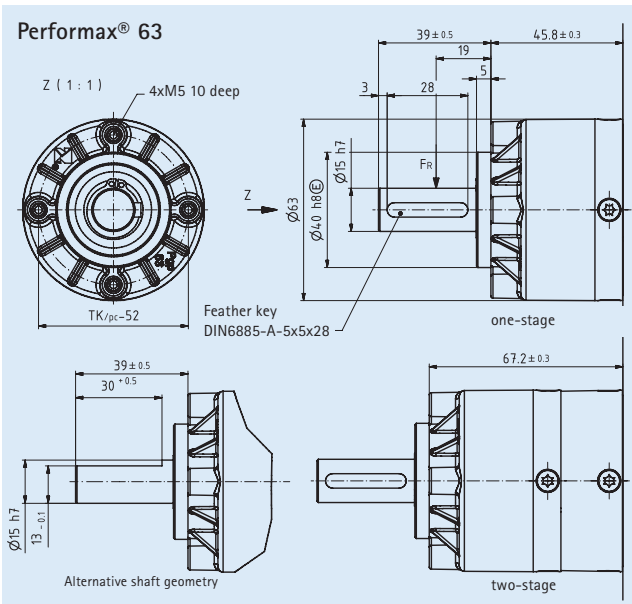
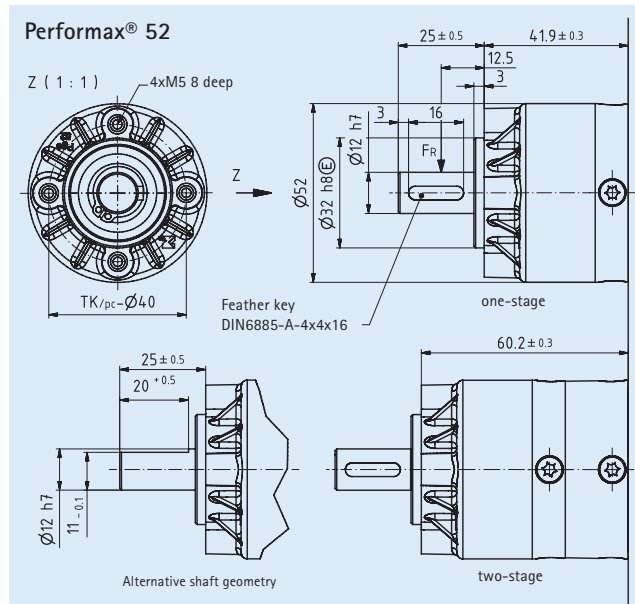
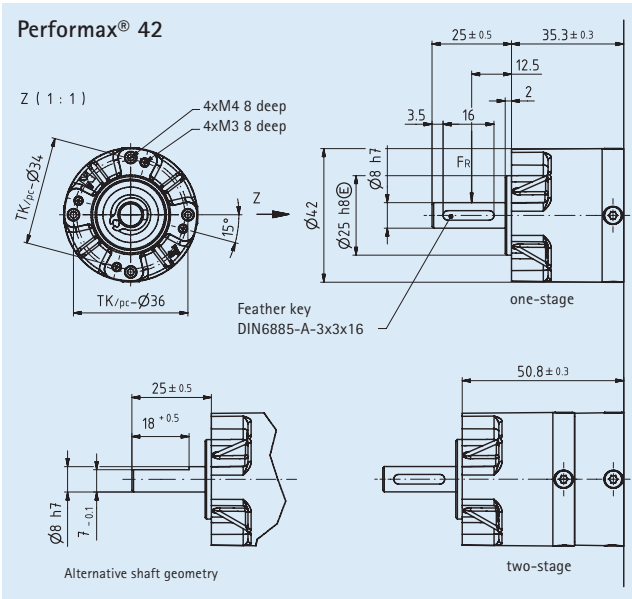
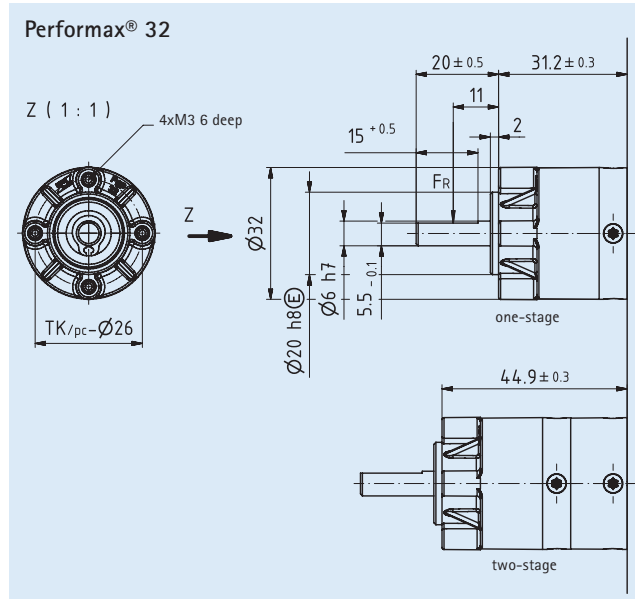

Performax® – ideal for challenging applications



Intralogistics

Hardly any other sector harbours as much savings and rationalisation potential as intralogistics. Effective Performax planetary gearhead drive solutions are used to optimise logistics processes. These gearheads combine outstanding power density and excellent smoothness with long life-time.

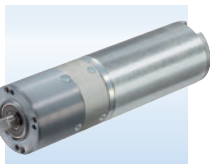

Special vehicle construction

When the fire service is called out, every minute counts. In an emergency, everything must be done right. In order to be able to respond quickly, the emergency services must have their technical equipment at the ready. The powerful Performax® Plus planetary gearhead guarantees reliability and robustness even under extremely challenging conditions.



Office equipment

Reliability, smoothness and durability are very much in demand in the office equipment sector. The fact that the design is as compact as possible whilst providing maximum power output and accommodating the highest radial loads makes our Performax HRL planetary gearhead tops in the sector.



Solutions for custom requirements



High-quality drive solutions demand perfection

Our competent engineering solutions are moving the market and setting benchmarks in industry. These facts have established us as a recognised technological leader.

Increasing our customers' success even further – motivates us particularly. To this end, we achieve top performance in every project and settle for nothing less than the best in terms of quality. For us, nothing is more important than using our top technologies to turn your visions into reality.

ZEITLAUF® – assuring you the decisive lead in your markets.



The focus is on your requirements

You will get a comprehensive performance package from us: from individual products from our standard modular system through tailor-made modified gearhead motors through to special developments as complete performances.

The ongoing intensive sounding out of new possibilities coupled with first-class engineering and maximum production quality guarantee us our leading role on the driving technologies market.

In-house software developments for the calculation and simulation of tooth-gear designs, basic research on the manufacturing of gear teeth, production of own rolling slotting machines as well as research projects with renowned colleges of higher education and technology companies underline our high level of competence.

With strict quality management in all internal processes and continual endurance tests we create an enormous added value for you and secure you worthwhile value creation advantages.

ZEITLAUF® is your competent partner for successful drive solutions.

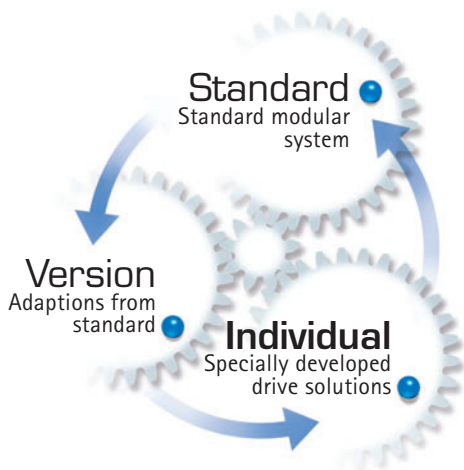

Our standard modular system – a unique concept



4,039 Drive solutions

For each demand, we have the correct drive. A high standard of engineering competency and logistical finesse, for optimal achievement and maximum efficiency, in an unbeatable modular system:

- 4,039 different drive solutions with unique power densities and application ranges
- "Assembling on demand" – fast and customised combination of the components you need to the highest standard of perfection.



48 Hours service

We react flexibly to the demands of a market with short-lived tendencies. After receipt of the order, we are able to dispatch to you your specifically configured drive – up to 20 pieces – within 48 hours*. Even a larger number of items and small-batch items can be ordered from our standard modular system.



Keep-Word-Warranty

We push back the limits with a singular warranty promise and go to exceptional lengths:

- replacement or repair of a defective gear motor, twice within a year – without question of blame
- an error log for the cause of failure with each return consignment
- in the case of overloading of the gear motor, you may exchange for a more powerful solution, which a full credit is applied to the price of the original drive cost



3D data available free of charge

For the purpose of speeding up and simplifying project planning, our Online Shop provides the user with all the specific data concerning our entire standard range. Users also benefit from a free CAD data call-up facility (3D models) in around 30 standard formats. It is simply not possible to design drive solutions faster and to better effect.



Standard modular system, online shop

Our unbeatable standard modular system is of course also available online. Our Internet portal contains a unique product configurator which you can use to put together all of our 4,039 solutions according to your specific requirements. Select and order the product you require intuitively, conveniently and smoothly.

Click our online shop – www.zeitlauf.com

* Subject to goods being sold.