



## Introduction

### This Manual

This manual describes the operation of the Chilli Dimmer. It is written for dimmers with the new white backlit user interface (see figure 1 - 1) running version 7.00 firmware onwards. For older dimmers with the green backlit user interface, please refer to the Issue 7 manual supplied with the dimmer.

This chapter contains a general overview of the unit followed by a brief description of the front panel controls and displays.

The Installation chapter provides information on installing the dimmer and connecting up the mains, loads, DMX, Chilli network and alarm input.

The User Interface chapter describes all the various functions of the dimmer which can be set up and operated via the front panel controls.

The manual concludes with a chapter on the technical specification of the dimmer.

### Conventions

Throughout this manual the following conventions are used. References to front panel controls appear in capital letters, for example:

ENT key, ESC key.

References to the LCD screen on the control panel are shown as follows:

DMX: 1 Temp: OK
--------------------

References to fields which appear on the LCD screen are shown in *italics*, for example:

*Manual Control, Set Chan Level etc.*

Dimmer Version	Breakers	Residual Current Device (RCD)	Mains Supply	Temperature Monitoring
Pro 4 x 10	Neutral Disconnect	-	Single Phase Only	-
Pro 4 x 10 HF	Neutral Disconnect	-	Single Phase Only	-
12 x 10	Single Pole	Option	Three Phase (see note)	Yes
Pro 12 x 10	Neutral Disconnect	Option	Three Phase (see note)	Yes
Pro 12 x 10 HF	Neutral Disconnect	-	Three Phase	-
12 x 16	Single Pole	Option	Three Phase (see note)	Yes
Pro 12 x 16	Neutral Disconnect	Option	Three Phase (see note)	Yes
24 x 10	Single Pole	Option	Three Phase (see note)	Yes
24 x 10 1212	Single Pole	Option	Three Phase (see note)	Yes
Pro 24 x 10	Neutral Disconnect	Option	Three Phase (see note)	Yes
Pro 24 x 10 1212	Neutral Disconnect	Option	Three Phase (see note)	Yes
Pro 24 x 16	Neutral Disconnect	-	Three Phase (see note)	Yes
Pro 24 x 16 1212	Neutral Disconnect	-	Three Phase (see note)	Yes
Pro 6 x 25	Neutral Disconnect	Option	Three Phase	Yes
Pro 24 x 10 Bypass	Neutral Disconnect	Option	Three Phase (see note)	Yes
Pro 24 x 16 Bypass	Neutral Disconnect	Option	Three Phase (see note)	Yes

**Table 1: Chilli Dimmer Variants**

## Note - Single Phase Conversion

Additional information detailing how to convert these dimmers for single phase operation is given in a separate document TU7806 available for download from the Zero 88 website.

## Overview

The Chilli Dimmers are available in several versions as shown in the table.

The channels may be patched as a block or individually to the DMX. The DMX control port supports RDM (Remote Device Management) functionality (version 7.00 firmware onwards).

Each channel has a manually adjustable output level. Each dimming channel can be set to follow one of four different dimming laws. Each relay channel must be set to 'switched' dimming law.

Preheat for individual channels can be set to between 0% and 20%. Each channel can be topsetted to limit its maximum output level.

Twelve programmable memories using an output grab method. Individual memories can be played back, when required. Editable memory fade times and channel levels.

Three programmable sequences using the memories. Sequences can be played back, when required.

DMX fail mode (DMX Hold, Fade to Black or Fade to Memory).  
Reset Dimmer function.

DMX status indication.

Alarm Input - alarm state and alarm messages (if networked).

HF ballast controller options of 0-10V analogue or DSI (410 HF and 1210HF versions only).

Lock function to prevent menu access.

Stand alone or network modes.

Areas assignable to channels in network mode, allowing memory and sequence playback on an area basis.

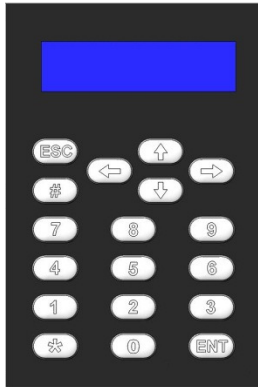

Figure 1-1: Control Panel

## Front Panel Controls

The control panel provides the user interface to the Chilli Dimmer.

### LCD Screen

The LCD screen comprises two lines of 16 characters. In this manual, the screen is shown as follows:

DMX: 1
Temp: OK

### Numeric Keys

The numeric keys (0 - 9) are used for entering numerical data (e.g. channel number, manual levels, DMX addresses etc.)

### Star Key

The function of the star key (\*) is not yet defined.

### Hash Key

The Hash key (#) is used to toggle the channel level between 0% and 100% in Manual Control or Edit memory.

### Cursor Keys

The cursor keys are used to scroll across menus, select options from a defined range, or increase or decrease the value in a selected field. The Up and Right keys are functionally identical. The Down and Left keys are functionally identical.

### Enter Key

The Enter key (ENT) is used to confirm numeric data entry, move down menu structures, confirm operations etc.

### Escape Key

The Escape key (ESC) is used to escape from the current menu to the menu level above.



Figure 2-1: The Chilli Pro 12 Channel Dimmer

## Installation

### Introduction

This chapter deals with installing the Chilli Dimmer and includes the following sections:

- Mounting the Dimmer
- Connecting to the Mains
- Load Connections
- DMX Connection
- Alarm Input Connection
- Chilli Network (Chilli Net)
- Network Terminals
- Termination Resistors
- Network Connection

**WARNING**  
**DISCONNECT THE DIMMER FROM THE MAINS SUPPLY**  
**BEFORE REMOVING THE FRONT COVER**

### 4 Channel Dimmers

This section covers the installation of the 4 X 10 and 4 X 10 HF dimmers.

### Mounting the Dimmer

The dimmer is provided with four 6mm diameter fixing holes for wall mounting. The mounting holes can be accessed by undoing the screws on the front cover and removing it.

The unit should be installed in a dry ventilated location, where ambient temperature and humidity are within the operating range of the unit (see chapter 4 for details).

The dimmers have ventilation slots on all sides to allow convection cooling and under no circumstances should these be blocked. Recommended minimum clearance around the dimmers is 100mm each side of the unit and 50mm above and below the unit if trunking with a depth greater than 50mm is used.

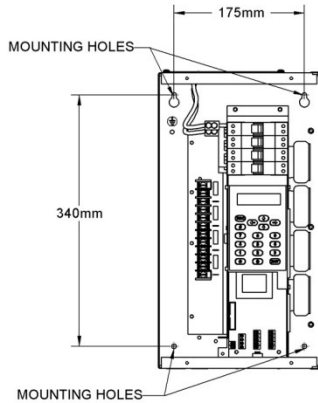

**Figure 2-2: Chilli Pro 4 Channel Dimmer**

## Connecting to the Mains

A separate isolator and secure mains earth are required. Phase to neutral voltage must not exceed 255V.

The dimmers are supplied with a selection of knockouts on the top of the dimmer for mains cable entry.

Appropriate cable glands should be fitted to the knockout holes provided to protect the mains cables from damage.

The 4 channel dimmers in the range are designed to run on a nominal 230V 50Hz single phase supply.

Ensure that all the mains connections are fully tightened and lock washers are used where supplied.

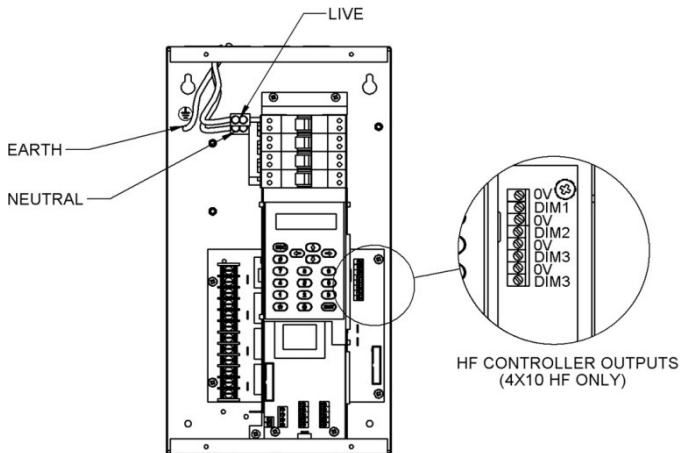

**Figure 2-3: Chilli Pro 4 Channel Dimmer**

## Load Connections

### 4 Channel Unit

The load cables are connected to the terminal strips located on the left hand side of the unit. The outputs will accept a maximum 6mm<sup>2</sup> cable.

Do not use a common neutral for multiple loads.

### 4 Channel HF Unit

The switched outputs are connected to the terminal strips located on the left hand side of the unit. The outputs will accept a maximum 6mm<sup>2</sup> cable.

Do not use a common neutral for multiple loads.

The HF controller outputs are connected to the terminal strip located on the right hand side of the unit and will accept a maximum 2.5mm<sup>2</sup> cable.

**NOTE - The HF controller outputs in this product are electrically isolated from mains earth and mains phase.**

They are only intended for connection to electronic ballasts for fluorescent fittings.

They are not intended to control, and should not be connected at any time, to any earth referenced electronics.  
**6 and 12 Channel Dimmers**

This section covers the installation of the 6 X 25, 12 X 10 and 12 X 16 dimmers.

### Mounting the Dimmer

The dimmer is provided with four 6mm diameter fixing holes for wall mounting.

The mounting holes can be accessed by undoing the screws on the front cover and removing it.

The unit should be installed in a dry ventilated location, where ambient temperature and humidity are within the operating range of the unit (see chapter 4 for details).

The dimmers have ventilation slots on all sides to allow convection cooling and under no circumstances should these be blocked. Recommended minimum clearance around the dimmers is 100mm each side of the unit and 50mm above and below the unit if trunking with a depth greater than 50mm is used.

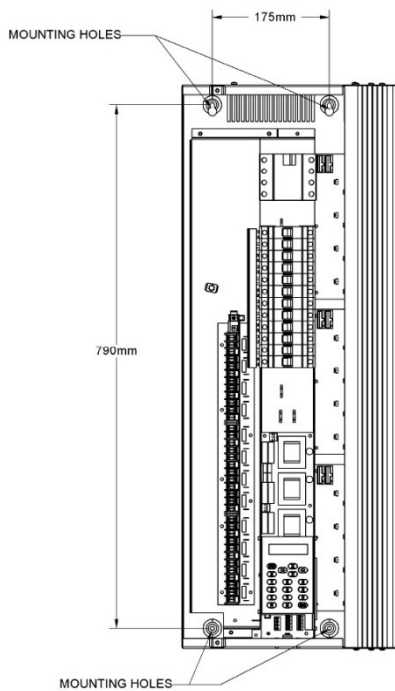

**Figure 2-4: Chilli 6 or 12 Channel Dimmer**

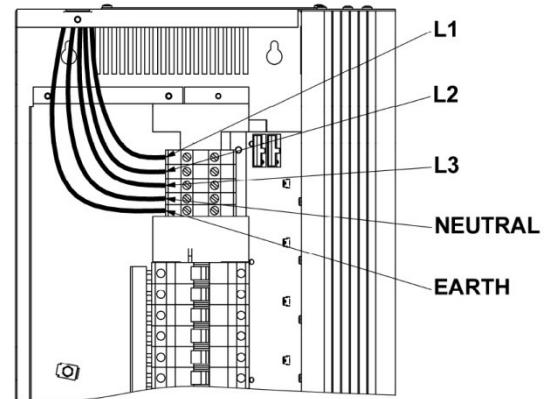
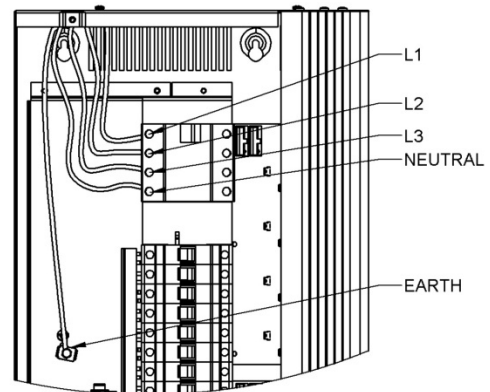

**Figure 2-5: Chilli 6 or 12 Channel Dimmer (No RCD)**

## Load Connections

### 6 and 12 Channel Units

The load cables are connected to the terminal strips located on the left hand side of the unit. The outputs are phase interleaved and the terminals are labelled L1, E, N1, L2, E, N2, etc. and will accept a maximum 6mm<sup>2</sup> cable. Do not use a common neutral for multiple loads.



**Figure 2-6: Chilli 6 or 12 Channel Dimmer (3 Phase RCD)**

## Connecting to the Mains

A separate isolator and secure mains earth are required. Phase to neutral voltage must not exceed 255V.

The dimmers are supplied with a selection of knockouts on the top of the dimmer for mains cable entry.

Appropriate cable glands should be fitted to the knockout holes provided to protect the mains cables from damage.

The 6 and 12 channel dimmers in the range are designed to run on a nominal 230V 50Hz 3-phase supply.

Ensure that all the mains connections are fully tightened and lock washers are used where supplied.

Other wiring options are available - please consult the factory for details.

## 12 Channel HF Dimmer

This section covers the installation of the 12 X 10 HF dimmer.

### Mounting the Dimmer

The dimmer is provided with four 6mm diameter fixing holes for wall mounting. The mounting holes can be accessed by undoing the screws on the front cover and removing it. The unit should be installed in a dry ventilated location, where ambient temperature and humidity are within the operating range of the unit (see chapter 4 for details).

The dimmers have ventilation slots on all sides to allow convection cooling and under no circumstances should these be blocked. Recommended minimum clearance around the dimmers is 100mm each side of the unit and 50mm above and below the unit if trunking with a depth greater than 50mm is used.

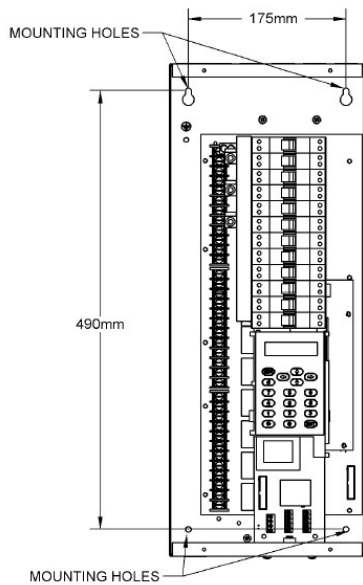

**Figure 2-7: Chilli Pro 1210 HF Dimmer**

## Connecting to the Mains

A separate isolator and secure mains earth are required. Phase to neutral voltage must not exceed 255V.

The dimmers are supplied with a selection of knockouts on the top of the dimmer for mains cable entry.

Appropriate cable glands should be fitted to the knockout holes provided to protect the mains cables from damage.

The 12 X 10 HF channel dimmer is designed to run on a nominal 230V 50Hz 3-phase supply.

Ensure that all the mains connections are fully tightened and lock washers are used where supplied.

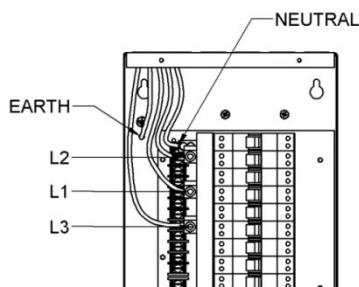

**Figure 2-8: Chilli Pro 1210 HF Dimmer – Wiring**

## Load Connections

### 12 Channel HF Unit

The switched outputs are connected to the terminal strips located on the left hand side of the unit. The outputs will accept a maximum 6mm<sup>2</sup> cable.

The outputs are phase interleaved and the terminals are labelled L1, E, N1, L2, E, N2, etc. and will accept a maximum 6mm<sup>2</sup> cable. Do not use a common neutral for multiple loads.

The HF controller outputs are connected to the terminal strip located on the right hand side of the unit and will accept a maximum 2.5 mm<sup>2</sup> cable.

The connectors are in 2 parts and the screw terminal parts may be removed from the PCB to ease making the connections.

If removed for wiring, ensure that the orientation is correct when replacing the connectors.

### Note

The HF controller outputs in this product are electrically isolated from mains earth and mains phase. They are only intended for connection to electronic ballasts for fluorescent fittings.

They are not intended to control, and should not be connected at any time, to any earth referenced electronics.

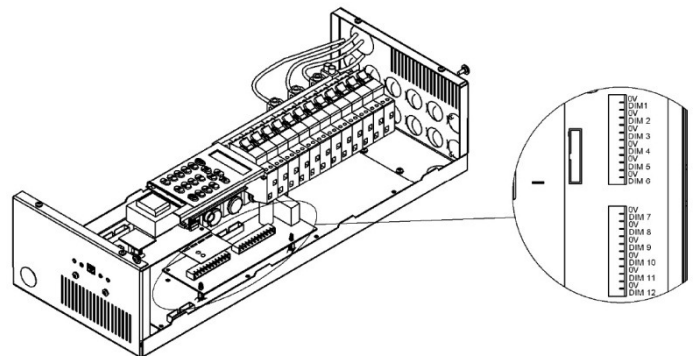

**Figure 2-9: Chilli Pro 1210 HF Dimmer – HF Controller Outputs**

## 24 Channel Dimmers

This section covers the installation of the 24 X 10 and 24 X 16 dimmers.

### Mounting the Dimmer

The dimmer is provided with four 6mm diameter fixing holes for wall mounting. The mounting holes can be accessed by undoing the screws on the front cover and removing it.

The unit should be installed in a dry ventilated location, where ambient temperature and humidity are within the operating range of the unit (see chapter 4 for details).

The dimmers have ventilation slots on all sides to allow convection cooling and under no circumstances should these be blocked.

Recommended minimum clearance around the dimmers is 100mm each side of the unit and 50mm above and below the unit if trunking with a depth greater than 50mm is used.

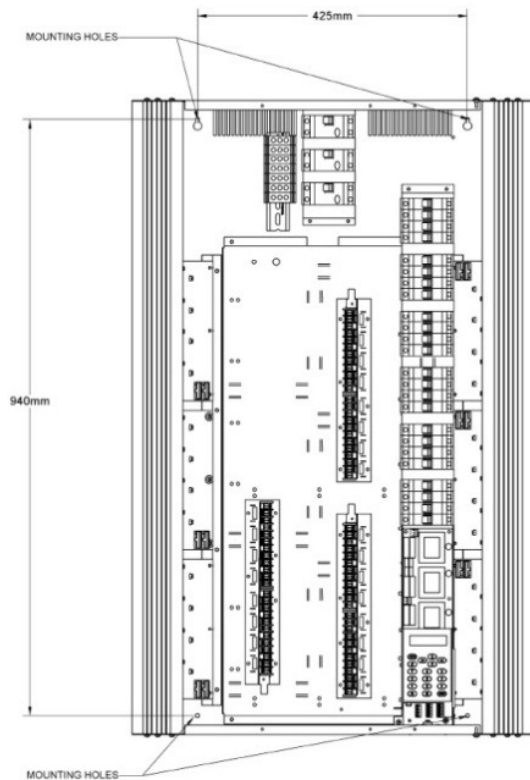

**Figure 2-10: Chilli 24 Channel Dimmer**

### Connecting to the Mains

A separate isolator and secure mains earth are required. Phase to neutral voltage must not exceed 255V. The dimmers are supplied with a selection of knockouts on the top of the dimmer for mains cable entry.

Appropriate cable glands should be fitted to the knockout holes provided to protect the mains cables from damage. The 24 channel dimmers are designed to run on a nominal 230V 50Hz 3-phase supply.

Ensure that all the mains connections are fully tightened and lock washers are used where supplied.

Other wiring options are available - please consult the factory for details.

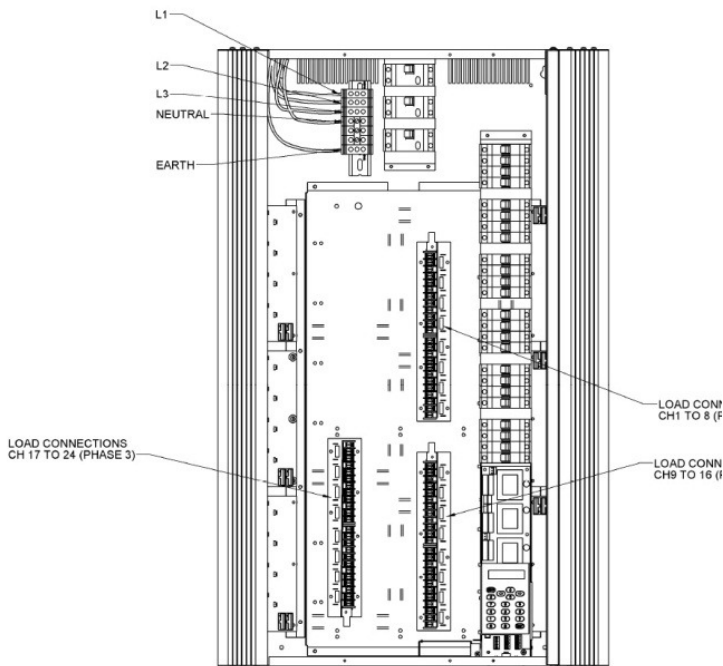

**Figure 2-11: Chilli 24 Channel Dimmer**

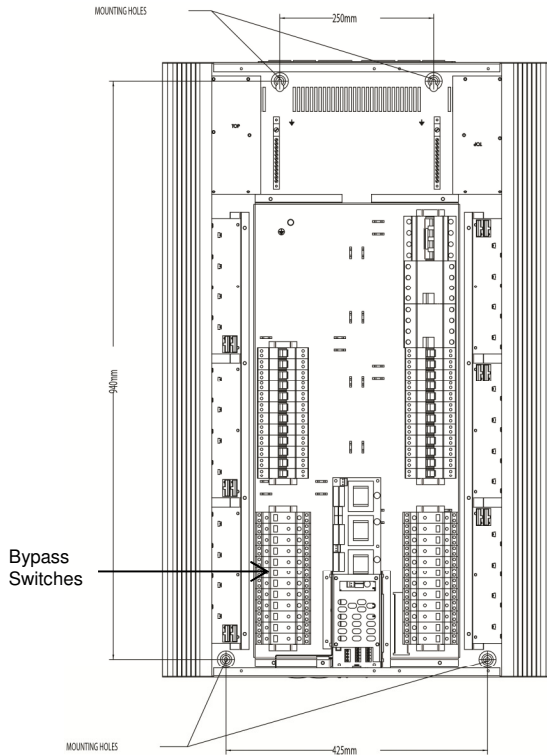

**Figure 2-12: Chilli 24 Bypass Channel Dimmer**

## Bypass switch unit

The Bypass unit includes 24 bypass switches for use when direct mains power is needed (e.g. for certain intelligent lights and LED light fittings). The dimming functionality on any of the 24 channels can be bypassed by pressing the relevant bypass switch (see 2-12). The bypass switches can be seen through a window in the door so that there is a visual indication of which channels are bypassed even when the door is locked.



## Load Connections

### 24 Channel Units

The load cables are connected to the terminal strips located in the centre of the unit in all versions other than the Bypass, where they are located at the top of the unit.

The outputs for the following units have output channels as follows:

### Triac only (Except units with Bypass switches) Non interleaved

Channels 1 - 8 Phase 1  
Channels 9 - 16 Phase 2  
Channels 17 - 24 Phase 3

### Triac & Relay (1212 versions) Non interleaved

Channels 1 - 4 Triac Phase 1  
Channels 5 - 8 Relay Phase 1

Channels 9 - 12 Triac Phase 2  
Channels 13 - 16 Relay Phase 2

Channels 17 - 20 Triac Phase 3  
Channels 21 - 24 Relay Phase 3

### Triac with Bypass switches Interleaved

Channels 1, 4, 7, 10, 13, 16, 19 & 22 Phase 1  
Channels 2, 5, 8, 11, 14, 17, 20 & 23 Phase 2  
Channels 3, 6, 9, 12, 15, 18, 21 & 24 Phase 3

Do not use a common neutral for multiple loads.

## DMX Connection

DMX input is connected through a 4-way screw terminal block located on the control PCB (Figure 2-11).

To loop through to another dimmer, simply connect both sets of wires into the same terminal block.

The terminals to be used are labelled RS485-, RS485+ and 0V.

The outputs for Bypass versions are interleaved with output channels as shown above.



## Network Connections

Connections for the ChilliNet network are located on the CPU card at the bottom of the unit with the cover removed. Zero 88 recommend Belden 1502P or 1502R data cable.

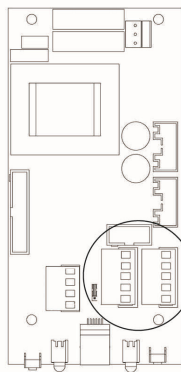

There are two 5-way green connectors for the network. Either of these may be used (as an in and an out) or a single used with the network cable doubled-up to it.

Please observe the standard wiring colour codes as follows:

Function	Belden 1502 Colour	Equivalent CAT5/6 Colour
+12V	Black	Green pair
CAN H	White	Blue
CANL	Silver	Brown pair
0V	Blue	Blue/white
Shield	Red	Orange pair

**IMPORTANT NOTE:** Connecting a mains potential cable to the ChilliNet Network terminals is likely to damage the unit and others connected, and invalidate warranty.

## Network Termination

Applies 120ohm resistor to the ChilliNet network. Required at each end of the network cable run only.

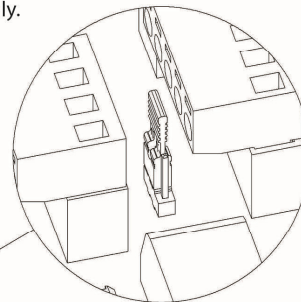
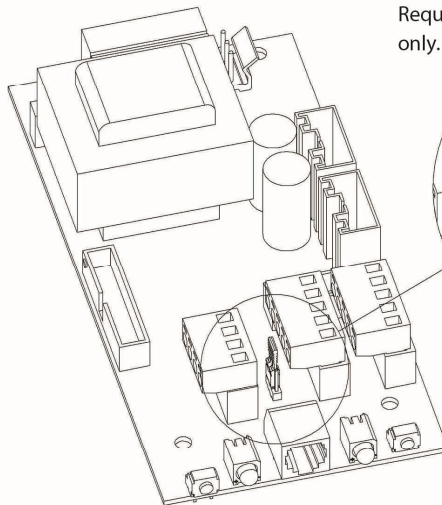

Termination On = Jumper across upper pins  
Termination Off = Jumper across lower pins

**IMPORTANT:** Remove jumper for all devices other than those at the the end-of-line.

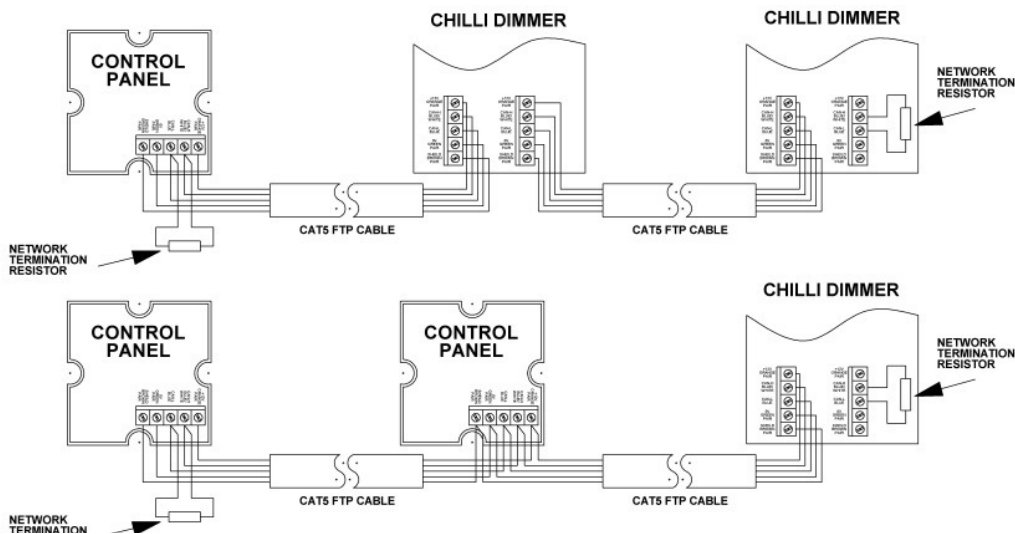

**Figure 2-13: Example Chilli Net System Schematic**

The connector is in 2 parts and the screw terminal part may be removed from the PCB to ease making the connections.

If removed for wiring, ensure that the orientation is correct when replacing the connector.

A 3-way DIP switch is located above the DMX terminations.

**Switch 1**

- TRIAC Units - Undefined.
- HF Units - Ballast Controller Mode:
- 0 - 10V Analogue - switch to left
- DSI - switch to right.

**Switch 2**

- Fail to ON - switch to left;
- Fail to OFF - switch to right

**Switch 3**

- DMX terminator OUT - switch to left;
- DMX terminator IN - switch to right

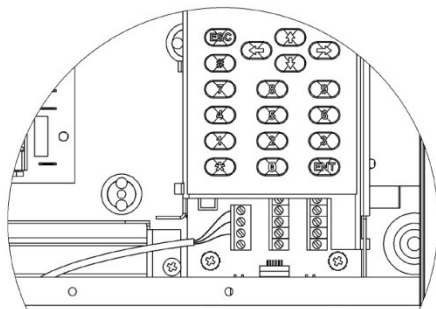

**Figure 2-14: DMX Connections**

**Alarm Input Connection**

The Alarm Input is connected through a 4-way screw terminal block located on the control PCB (Figure 2-15).

The terminals to be used for the Alarm Input are labelled 0V and AL. Any connection to the Alarm Input must be volt free and have a cable length of less than 50 metres. Cabling for this input should be segregated from power wiring.

The connector is in 2 parts and the screw terminal part may be removed from the PCB to ease making the connections. If removed for wiring, ensure that the orientation is correct when replacing the connector.

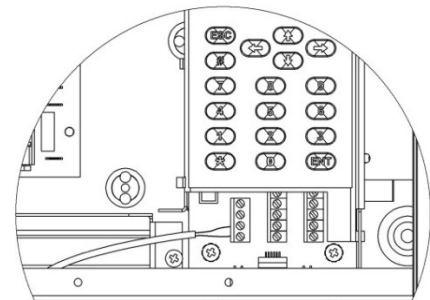

**Figure 2-15: Alarm Input Connections**

**Chilli Network (Chilli Net)**

The following devices can be connected to a Chilli Network system:

- Chilli Dimmer
- Chilli Control Panel
- Chilli Master Controller
- Chilli RS232 Node
- Chilli NetLink (hub)
- Spice Rack Dimmer
- Rack 6 / Install 6 Dimmers

Each device has a set of network terminals or an RJ12 socket provided for connection to the Chilli network.

The cable used to connect the various devices in the network must be CAT 5 (100MHz) FTP cable.

## Network Terminals

The Chilli Net terminals are labelled with the recommended colours of the pairs in CAT5 cable as follows:

Orange Pair	+12V
Blue/White	CAN-H
Blue	CAN-L
Green Pair	0V
Brown Pair	Shield

All devices in the Chilli network must be connected in serial. The devices in the network can be wired in any order (see examples in Figure 2-14 above).

## Termination Resistors

At the two ends of the Chilli network, a network termination resistor must be fitted (see Figure 2-13 above).

Each Chilli Dimmer is supplied with a termination resistor fitted. This resistor is 120 ohms, 0.25 Watt and is connected between the CAN-H and CAN-L terminals.

This resistor must be **removed**, unless the dimmer is at either end of the Chilli network.

## Network Connection

All network and control cables should enter the dimmer through the segregated route at the bottom of the dimmer. Segregation between control data cabling and power wiring should be maintained for reasons of safety and noise immunity.

Control data cabling should be run in separate or divided metal trunking or conduits. Where cables are run outside trunking or conduits there should be 300mm separation between them and where they cross they should do so at right angles.

Inside the dimmer, the terminals for network connections use two part connectors. Pull the connector from the PCB, connect the wires from the CAT 5 cable and push the connector back onto the PCB, ensuring correct orientation (see figure 2-15).

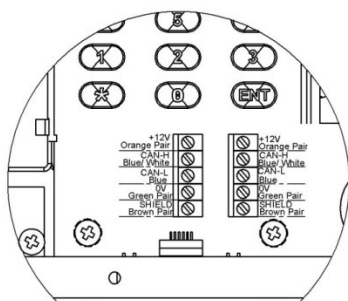

Figure 2-15: Network Connections

## User Interface

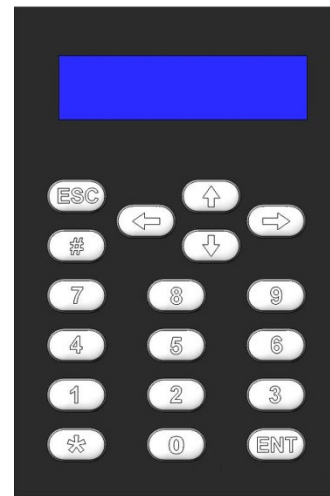

Figure 3-1: Control Panel

## Introduction

This chapter describes all the various dimmer functions. There are certain variations in menu options and screen displays between **Stand Alone** and **Network** modes.

## Main Screen

The main screen is shown shortly after the dimmer is powered up, and also if the user interface is not used for a period of 30 seconds. The data shown on the main screen depends on the operating mode and state of the dimmer as follows:

In **Stand Alone Mode** - the screen shows the *DMX* and *Temp* fields:

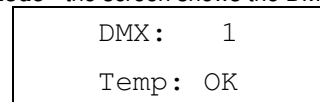

In **Network Mode** - the screen shows the *DMX* and *Chilli Net* fields:

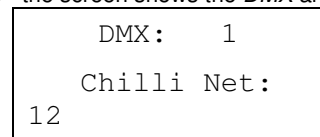

In the **Alarm State** - the screen shows:

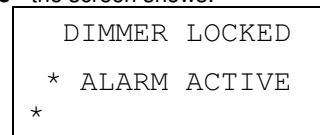

## DMX Field

The *DMX* field shows the status of the DMX input signal as follows.

Receiving valid DMX dimmer data:  
“DMX: xxx” (DMX start address), or  
“DMX: Patched”.

Receiving invalid DMX data:  
“NOT DIMMER”.

DMX errors are occurring:  
“DATA ERROR”.

No DMX data being received:  
“NO DATA”.

DMX input disabled:  
“DMX: DISABLED”

## Temp Field

The *Temp* field is shown on certain dimmers only – see Table 1 – and shows the temperature sensor state:

Internal temperature sensor fault:  
“Temp: No Val” (see note).

Normal operating temperature (<80 C)  
“Temp: OK”.

Hot (80 - 90 C):  
“Temp: HOT”.

Overheat shutdown (> 95 C)  
“Temp: FAIL”.

## Chilli Net Field

If the dimmer is operating in **Network Mode**, the second line of the screen shows “Chilli Net: xx”, where xx is the dimmer number. If the dimmer is in ‘dumb’ mode as a result of conflicting dimmer numbers on the network, the screen shows: “Chilli Net: CON”.

### Note

#### Temperature Field at Startup

The text “Temp: No Val” is shown briefly at startup as the dimmer is reading the sensor. This is normal behaviour.

## Menu Structure

From the Main Screen, press the ENT key to enter the menu structure. The menu structure is cyclic and the cursor keys are used for navigation.

After selecting a top level menu option, press the ENT key to enter the corresponding sub-menu. Hitting the ESC key on a screen generally returns to the menu level above the current one, except where specifically stated in this manual.

The top level menu options are:

- *Manual Control*
- *Memories*
- *Sequences*
- *Preheat*
- *Dimmer Laws*
- *Topset*
- *Reset Dimmer*
- *DMX Controls*
- *Security*
- *Chilli Net*
- *Area Control*

When there are other menu options available at the same level < and > symbols will appear at the left and right hand sides of the screen. For example:

```
<Manual  
Control>
```

## Manual Control

Select the *Manual Control* option from the top level menu options, and press the ENT key to enter the *Manual Control* menu. The following options are available:

- *Set Chan Level*
- *Set All Chans*

Use the cursor keys to scroll between the options. Press the ENT key to enter the menu for the selected option.

## Set Channel Level

This option allows you to set up a manual control level between 0 - 100% for each of the dimmer channels.

Select the *Set Chan Level* option from the menu, and press the ENT key to enter the menu.

**Stand Alone Mode** - the screen shows:

```
Channel: xx  
Level: xxx
```

The cursor is shown in the *Channel* field.

**Network Mode** - the screen shows:

```
A (xx) Channel :
xx
Level: xxx
```

The cursor is shown in the *Channel* field.  
The area number A(xx) shows the area that the dimmer channel is assigned to and is for information only.

In **Stand Alone** or **Network Mode**, individual channel levels can then be adjusted using the numeric keypad or cursor keys. Press the ENT key to move between the *Channel* and *Level* fields.

### Note - Using the # Key

The # key can be used as a quick method of setting the manual control levels to full or off. The first push will take it 100%, the second push will take it 0% etc.

### Set All Channels

**Stand Alone Mode** - Allows you to set a manual control level for all the channels on the dimmer in a single operation. Select the *Set All Chans* option from the menu, and press the ENT key. The screen shows:

```
All Channels
Level: 0
```

### Set All Channels

**Network Mode** - allows you to set a manual control level for all the channels in a specified area on the dimmer in a single operation. Select the *Set All Chans* option from the menu, and press the ENT key. The screen shows:

```
Area: 1
Level: 0
```

The cursor is in the *Area* field. Press the ENT key to move between the *Area* and *Level* fields. The area number must be valid (i.e. the dimmer has one or more channels assigned to that area) to adjust the *Level* field.

### Memories

The Chilli Dimmer can be programmed with up to 12 memories. The memories are programmed by grabbing the current outputs. The programmed memories can then be played back, when required. The channel levels and fade times for programmed memories can be edited.

In **Network Mode** - memories are recorded, played back, edited and cleared on an area basis.

### Memory Options

Select the *Memories* option from the top level options menu, and press the ENT key to enter the Memories menu. The following options are available:

- *Record Memory*
- *Play Memory*
- *Clear Memories*
- *Edit Memory*

Use the cursor keys to scroll between the options, then press the ENT key to enter the selected option.

### Record Memory

**Stand Alone Mode** - This option allows you to store the current **output levels** in one of the 12 memories in the dimmer. The fade time can also be adjusted, if required, during this operation. It is recommended that when recording memories, the topset level for all channels is set to 100%.

Select the *Record Memory* option from the Memories menu, and press the ENT key. The screen shows:

```
Record Memory
xx
```

The cursor appears in the memory number field (xx). Unprogrammed memories are indicated by an '\*' next to the memory number. Use the numeric keypad or cursor keys to select the required memory (1 - 12).

Press the ENT key to confirm the memory selection. The screen shows:

```
Memory: xx
Fade Time: xx
```

The *Memory* field is for information only and is not editable. The cursor appears in the *Fade Time* field. Use the numeric keypad or cursor keys to adjust the fade time as required (1 - 60 seconds).

Press the ENT key to save the fade time to the memory. The dimmer will then grab the current **output levels** and store them in the selected memory.

The screen will briefly show a confirmation, and then return to the *Record Memory* screen.

## Record Memory

**Network Mode** - This option allows you to store the current **output levels** in one of the 12 memories in the dimmer. Only the levels of the dimmer channels assigned to the specified area are recorded into the memory.

The fade time can also be adjusted, if required during this operation. It is recommended that when recording memories, the topset level for all channels is set to 100%.

Select the *Record Memory* option from the Memories menu, and press the ENT key. The screen shows:

Area: 1 Memory: xx
-----------------------

The cursor is in the *Area* field. Enter the required area number using the numeric keypad or cursor keys, then press the ENT key. If the area is valid, the cursor moves to the *Memory* field.

Use the numeric keypad or cursor keys to select the required memory (1 - 12).

Unprogrammed memories have an "\*" next to the memory number. Press the ENT key to confirm the memory selection. The screen shows:

Area xx Mem xx Fade Time: xx
---------------------------------

The *Area* and *Mem* fields are for information only. The cursor appears in the *Fade Time* field.

Use the numeric keypad or cursor keys to adjust the fade time as required (1 - 60 seconds).

Press the ENT key to save the fade time to the memory. The dimmer will then grab the current **output levels** for the selected area and store them in the selected memory.

The screen will briefly show a confirmation, and then return to the *Record Memory* screen.

## Play Memory

**Stand Alone Mode** - This option allows you to playback (output) one of the 12 memories programmed in the dimmer.

Select the *Play Memory* option from the Memories menu, and press the ENT key. The screen shows:

Playback Memory xx
-----------------------

The cursor appears in the memory number field (xx). If a memory is currently being output, then that number is shown in the field. Use the numeric keypad or cursor keys to select a memory to be output (0 - 12).

Press the ENT key to confirm the memory number selection. The dimmer performs the following:

**Memory Zero** - The outputs fade to zero in 3 seconds, and replace any previous memory or sequence being output.

**Programmed Memory** - The outputs fade to those in the selected memory in the memory's fade time, and replace any previous memory or sequence being output.

**Unprogrammed Memory** - \* is displayed and the outputs do not change.

The screen returns to the *Play Memory* screen.

### Note - Memory Zero

*Memory Zero is a fixed, non-editable memory, with a fade time of 3 seconds and all channels programmed at 0%.*

### Note - Memory Playback

**Stand Alone Mode** - A dimmer can only play back one memory at a time.

**Network Mode** - A dimmer can only play back one memory per area at a time, but may play back up to ten different memories if they are all in different areas.

## Play Memory

**Network Mode** - This option allows you to playback (output) one of the 12 memories programmed in the dimmer, or any other dimmer on the network, on an area basis.

Select the *Play Memory* option from the Memories menu, and press the ENT key. The screen shows:

Area: 1 Memory: xx
-----------------------

The cursor is in the *Area* field. Enter the required area number using the numeric keypad or cursor keys, then press the ENT key.

If the area number is valid, the cursor moves to the *Memory* field. If a memory for the selected area is currently being output from the dimmer, then that number is shown.

Use the numeric keypad or cursor keys to select a memory to be output (0 - 12).

Press the ENT key to confirm the memory number selection. The dimmer sends out the corresponding Play Memory / Area message onto the network.

If the dimmer has one or more channels assigned to the specified area it performs the following:

**Memory Zero** - The outputs fade to zero in 3 seconds, and replace any previous memory or sequence being output for the **selected area**.

**Programmed Memory** - The outputs fade to those in the selected memory in the memories fade time, and replace any previous memory or sequence being output for the **selected area**.

**Unprogrammed Memory** – \* is displayed and the outputs do not change.

The screen returns to the *Play Memory* screen.

## Clear Memories

**Stand Alone Mode** - This option allows you to clear all the 12 memories in the dimmer.

Select the *Clear Memories* option from the Memories menu, and press the ENT key. The screen shows:

Press ENT key to  
clear memories

Press the ENT key to clear all the memories and any programmed sequences in the dimmer.

The screen returns to the *Memories* screen.

## Clear Memories

**Network Mode** - This option allows you to clear all the 12 memories for a specified area in the dimmer.

Select the *Clear Memories* option from the Memories menu, and press the ENT key. The screen shows:

Area: 1  
ENT to clear

The cursor appears in the Area field. Use the numeric or cursor keys to select the required area number (0-10), then press the ENT key.

**Area 0: This is a special case.** The dimmer will clear all stored memories for all areas, and all programmed sequences on the dimmer.

**Area 1 -10:** The dimmer will clear all the stored memories for the selected area, and any programmed sequences for the selected area on the dimmer.

The screen returns to the *Memories* screen.

## Edit Memory

**Stand Alone Mode** - This option allows you to edit the channel values and fade time of a programmed memory stored on the dimmer.

Select the *Edit Memory* option from the Memories menu, and press the ENT key. The screen shows:

Edit Memory  
Xx

If the memory is **unprogrammed** - a star (\*) is shown next to the memory number and the memory cannot be edited.

Use the numeric keypad or cursor keys to select the required memory (1-12), then press the ENT key to confirm.

If the memory is **programmed** - the dimmer **outputs** the selected memory and the screen shows:

Channel: 1  
Level: xxx

The cursor is shown in the *Channel* field. The *Level* field shows the programmed value for the channel.

Adjust the level of each channel as required. This operation uses the same user interface as the *Set Channel Level* function in *Manual Control*.

Press the ESC key. The screen shows:

Memory: xx  
Fade Time: xx

The *Memory* field is for information only. The cursor appears in the *Fade Time* field.

Use the numeric keypad or cursor keys to adjust the fade time as required (1 - 60 seconds).

Press the ENT key to save the fade time and the channel levels into the memory. The screen briefly shows a confirmation, and then returns to the *Edit Memory* screen.

The memory is removed from the outputs.

## Edit Memory

**Network Mode** - This option allows you to edit the channel values and fade time of a programmed memory for a selected area stored on the dimmer.

Select the *Edit Memory* option from the Memories menu, and press the ENT key. The screen shows:

Area: 1  
Memory: xx

If the memory for the chosen area is **unprogrammed** - a star (\*) is shown next to the memory number and the memory cannot be edited.

The cursor appears in the *Area* field. Enter the required area number using the numeric keypad or cursor keys, then press the ENT key. If the area number is **valid**, the cursor moves to the *Memory* field.

Use the numeric keypad or cursor keys to select the required memory (1 - 12), then press the ENT key to confirm.

If the memory for the chosen area is **programmed** - the dimmer **outputs** the selected memory and the screen shows:

A(xx)Channel: 1  
Level: xxx

The area number field A(xx) is for information only. The cursor is shown in the *Channel* field.

The *Level* field shows the programmed value for that channel in the memory.

Adjust the level of each channel as required. This operation uses the same user interface as the *Set*

*Channel Level* function in *Manual Control*.

## Note

Only those channels which are assigned to the specified area may be selected and edited.

Press the ESC key. The screen shows:

```
Area xx Mem xx
Fade Time: xx
```

The Area and Memory fields are for information only and are not editable.

The cursor appears in the Fade Time field. Use the numeric keypad or cursor keys to adjust the fade time as required (1 - 60 seconds).

Press the ENT key to save the fade time and the channel levels into the memory.

The screen will briefly show a confirmation, and then return to the *Edit Memory* screen.

The memory is removed from the outputs.

## Sequences

The Chilli Dimmer can be programmed with up to 3 different sequences, each containing a maximum of 12 steps.

In **Stand Alone Mode** - Each step in a sequence is a reference to one of the **programmed** memories in the dimmer.

In **Network Mode** - Each sequence is associated with a specific area. Each step in a sequence is a reference to a memory in that area, but the memory does **not** have to be programmed in the dimmer itself.

Each sequence also has a cross-fade and dwell time which determines how the sequence runs:

**X-Fade Time** - The cross-fade time is the time it takes to fade between two steps in a sequence. The default crossfade time is 1 second.

**Dwell Time** - The dwell time is the time that the outputs remain on the values in the current step of the sequence before fading to the next step. The default dwell time is 1 second.

## Sequence Menu Options

Select the *Sequences* option from the top level options menu, and press the ENT key to enter the Sequences menu. The following options are available:

- *Program Sequence*
- *Playback Sequence*
- *Sequence Options*

## • *Clear Sequence*

Use the cursor keys to scroll between the options.

Press the ENT key to enter the selected option.

## Program Sequence

**Stand Alone Mode** - This option allows you to program one of the three sequences, using the programmed memories in the dimmer.

Select the *Program Sequence* option from the Sequences menu, and press the ENT key, the screen shows:

```
Select
Sequence: 1
```

Use the numeric or cursor keys to select the required sequence number, then press the ENT key. The screen shows:

```
Seq 1 Step: 1
Memory: xx
```

The cursor appears in the *Step* field.

The *Memory* field shows the contents of the step, if programmed, or "xx" if the step is not programmed.

Select the **first** step in the sequence, then press the ENT key. The cursor moves to the *Memory* field.

Use the cursor keys to select one of the **programmed** memories in the dimmer. Press the ENT key to assign the memory to the selected step. The cursor returns to the *Step* field.

Use the cursor keys to select the **next** step in the sequence, then press the ENT key. The cursor moves to the *Memory* field.

Use the cursor keys to select one of the **programmed** memories in the dimmer. Press the ENT key to assign the memory to the selected step. The cursor returns to the *Step* field.

Repeat the above process until all the steps in the sequence have been programmed (maximum of 12 steps).

## Program Sequence

**Network Mode** - This option allows you to program any of the three sequences in the dimmer with memories for a specific area.

Select the Program Sequence option from the Sequences menu, and press the ENT key. The screen shows:

```
Sequence: 1 (Axx)
Area: 1
```

The cursor appears in the *Sequence* field. Use the numeric or cursor keys to select the required sequence number.



Press the ENT key. The cursor moves to the *Area* field. Use the numeric or cursor keys to select the required area. Press the ENT key. The screen shows:

```
Seq 1 Step: 1(Axx)
Memory: xx
```

The cursor appears in the *Step* field. The *Memory* field shows the contents of the step, if programmed, or "xx" if not programmed.

Select the **first** step in the sequence, then press the ENT key. The cursor moves to the *Memory* field.

Use the cursor keys to select the required memory number (1 - 12). Press the ENT key to assign the memory to the selected step. The cursor returns to the *Step* field.

Use the cursor keys to select the **next** step in the sequence, then press the ENT key. The cursor moves to the *Memory* field.

Use the cursor keys to select the required memory number (1 - 12). Press the ENT key to assign the memory to the selected step. The cursor returns to the *Step* field.

Repeat the above process until all the steps in the sequence have been programmed (maximum of 12 steps).

## Playback Sequence

**Stand Alone Mode** - This option allows you to playback any of the three programmed sequences, and start and stop sequences running. Only one sequence can be running at a time.

Select the *Playback Sequence* option from the Sequences menu, and press the ENT key. If there is no sequence currently running in the dimmer, the screen shows:

```
Sequence: 1
ENT to start
```

If sequence X is currently running in the dimmer, the screen shows:

```
Sequence: X
ENT to stop
```

Use the cursor keys to select the required sequence. The second line of the screen shows the current state of the selected sequence.

### Starting a Sequence

Select the required sequence using the cursor keys, then press the ENT key.

The sequence will start running and replace any memory or sequence which was previously being output.

### Stopping a Sequence

Select the sequence that is currently running in the dimmer using the cursor keys, then press the ENT key.

The sequence will stop running.

## Playback Sequence

**Network Mode** - This option allows you to playback any of the three programmed sequences, and start and stop sequences running. Only one sequence can be running at a time.

Select the *Playback Sequence* option from the Sequences menu, and press the ENT key. If there is no sequence currently running in the dimmer, the screen shows:

```
Sequence: 1
ENT to start
```

If sequence X is currently running in the dimmer, the screen shows:

```
Sequence: X
ENT to stop
```

Use the cursor keys to select the required sequence. The second line of the screen shows the current state of the selected sequence.

## Starting a Sequence

Select the required sequence using the cursor keys, then press the ENT key.

The sequence will start running. The dimmer sends out a start sequence message onto the network, and then play memory / area messages at the appropriate times.

Starting a sequence in an area will replace any memory or sequence for that area currently being output by the dimmer.

## Stopping a Sequence

Select the sequence that is currently running in the dimmer using the cursor keys, then press the ENT key.

The sequence will stop running. The dimmer sends out a stop sequence message onto the network.

## Sequence Options

This option allows you to adjust the crossfade and dwell times for the sequences in the dimmer.

These times are global and apply to all three sequences in the dimmer.

Select the *Sequence Options* option from the Sequences menu, and press the ENT key, the screen shows:

```
X-Fade Time: xx
Dwell Time: xxx
```

The cursor appears in the *X-Fade Time* field. Use the numeric keypad or cursor keys to adjust the fade time as required (range 1 - 60 seconds).

Press the ENT key to confirm the crossfade time. The cursor moves to the *Dwell Time* field.

Use the numeric keypad or cursor keys to adjust the dwell time as required (range 1 - 600 seconds).

Press the ENT key to confirm the dwell time. The cursor moves to the *X-Fade Time* field.

## Clear Sequence

This option allows you to clear any of the sequences in the dimmer. Select the *Clear Sequence* option from the Sequences menu, and press the ENT key, the screen shows:

Select  
Sequence: 1

Use the numeric keypad or cursor keys to select the required sequence, then press the ENT key, the screen shows:

Push ENT key to  
clear sequence

Press the ENT key. The screen returns to the *Clear Sequence* screen.

## Preheat

Select the *Preheat* option from the top level menu options, and press the ENT key to enter the Preheat menu. The following two options are available:

- Set Preheat
- Clear Preheats

### Set Preheat

This option allows you to set up a preheat level (between 0 - 20%) for **each** of the dimmer channels.

Select the *Set Preheat* option from the menu, and press the ENT key. The screen shows:

Channel: xx  
Level: xx

The cursor is shown in the *Channel* field. Press the ENT key to move between the *Channel* and *Level* fields, and adjust the values using the numeric keypad or cursor keys.

### Clear Preheats

This option allows you to clear the preheat levels for **all** of the dimmer channels to 0%.

Select the *Clear Preheats* option from the menu, and press the ENT key. The screen shows:

Push ENT key to  
Clear Preheats

Press the ENT key to set all the channel preheat levels to 0%.

## Dimmer Laws

You can choose a dimmer law for **each** of the Triac dimmer channels, however only the Switched Law should be used on the relay card channels.

The dimmer laws determine the relationship between the control value and the output value supplied to the lamp.

The laws are characterised for TRIAC dimmers only. On the Chilli HF ballast controller, the results obtained may be different from those shown below, depending on the ballast used.

**Normal** - The standard output of the dimmer.

**Linear** - Suitable for most live or theatrical situations.

**Switch** - Output switches from zero to full when the input reaches 50%.

**Square** - For use with video cameras.

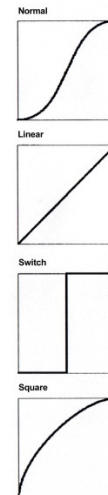

Figure 3-2: Dimmer Laws

## Set Laws

This option allows you to set up the dimmer law for each of the Triac dimmer channels.

Select the *Dimmer Laws* option from the top level menu options, and press the ENT key to enter the Dimmer Laws menu.

Select the *Set Laws* option from the menu, and press the ENT key. The screen shows:

Channel: xx  
Law: xxxxxx

The cursor is shown in the *Channel* field.

The channel is selected using the numeric keypad or cursor keys. Press the ENT key to move between the *Channel* and *Law* fields.

When the cursor is in the *Law* field, the cursor keys cycle through the laws.

The currently selected law for the channel is indicated by a “\*”, for example:

Channel: 10  
 Law: Normal\*

## Reset Laws

This option allows you to reset the dimmer laws for all dimmer channels.

Select the *Dimmer Laws* option from the top level menu options, and press the ENT key to enter the Dimmer Laws menu.

Select the *Reset Laws* option from the menu, and press the ENT key. The screen shows:

Push ENT key to  
 reset all laws

Press the ENT key to set the state of all Triac laws to normal, and Relay Laws to Switched. The screen will briefly show a confirmation, and then return to the *Dimmer Laws* screen.

## Topset

The Topset function is used to apply a scaling factor to the **final output level** of a channel, such that the input control range gets compressed into a smaller output range.

For example - If the input level of a channel is 80% and the Topset level of the channel is 50%, the output level will be  $80\% \times 50\% = 40\%$ .

## Topset Menu Options

Select the *Topset* option from the top level menu options, and press the ENT key to enter the Topset menu. The following two options are available:

- Set Topset
- Clear Topsets

## Set Topset

This option allows you to set up a topset level (between 0 - 100%) for each of the dimmer channels.

Select the *Set Topset* option from the menu, and press the ENT key. The screen shows:

Channel: xx  
 Level: xx

The cursor is shown in the *Channel* field. Press the ENT key to move between the *Channel* and *Level* fields, and adjust the values using the numeric keypad or cursor keys.

## Clear Topsets

This option allows you to clear (reset) the topset levels for all of the dimmer channels to 100%.

Select the *Clear Topsets* option from the menu, and press the ENT key. The screen shows:

Push ENT key to  
 Clear Topsets

Press the ENT key to set all the topset levels to 100%.

## Reset Dimmer

This option allows you to reset the dimmer to its default settings which are defined as follows:

- All Triac dimming laws set to Normal.
- All Relay dimming laws set to Switched.
- Preheat for all channels off (0%).
- All memories cleared.
- All memory fade times reset to 3s.
- All sequences cleared.
- Sequence crossfade reset to 1s.
- Sequence dwell time reset to 1s.
- DMX Fail mode - Fade to Black.
- DMX Address set to 1.
- DMX Input Mode - HTP Mix.
- RDM set to enabled.
- All Manual Control levels set to 0%.
- All Topset levels set to 100%.
- Chilli Net set to disabled.
- All channels assigned to Area 1.

Select the *Reset Dimmer* option from the top level options menu, and press the ENT key. The screen shows:

Push ENT key to  
 Reset Dimmer

Press the ENT key. The screen shows:

Push ENT key to  
 Confirm Reset

Press the ENT key to reset the dimmer as described above. The screen returns to the main screen.

## DMX Controls

This option allows you to set the DMX start address for the dimmer, patch individual channels to the DMX, or reset the DMX patch to default.

This option also allows you to decide how the DMX input signal is processed by the dimmer and set the DMX fail mode, where applicable.

Select the *DMX Controls* option from the top level menu options, and press the ENT key to enter the DMX Controls menu. The following options are available:

- Set Start Address
- Set DMX Patch
- Reset DMX Patch
- DMX Input
- RDM

## Set Start Address

This option allows you to set a DMX start address for the dimmer. The dimmer channels are then patched automatically as a contiguous block starting at the specified address.

Select the *Set Start Address* option from the menu, and press the ENT key. The screen shows:

DMX Address  
xxx

Enter the DMX address using the numeric keypad or cursor keys, then press the ENT key.

This sets the start address for the dimmer. The screen pauses briefly and then returns to the *DMX Controls* screen.

## Valid DMX Start Addresses

- 4 channel dimmer: 1 - 509
- 6 channel dimmer: 1 - 507
- 12 channel dimmer: 1 - 501
- 24 channel dimmer: 1 - 489

## Set DMX Patch

This option allows you to set an individual DMX address (1 - 512) for **each channel** of the dimmer.

Select the *Set DMX Patch* option from the menu, and press the ENT key. The screen shows:

Channel: xx  
DMX: xxx

The cursor appears in the *Channel* field. Press the ENT key to move between the *Channel* and *DMX* fields, and adjust the values using the numeric keypad or cursor keys.

## Reset DMX Patch

This option allows you to reset the start DMX address for the dimmer to DMX channel 1.

Select the *Reset DMX Patch* option from the menu, and press the ENT key. The screen shows:

Push ENT Key to  
Reset DMX Patch

Press the ENT key to reset the DMX patch. The screen returns to the *Reset DMX Patch* screen.

## DMX Input Modes

This option allows you to enable or disable the DMX input signal to the dimmer without having to physically disconnect the DMX cable.

When the DMX input is **enabled**, you can choose between two modes of operation - HTP mixing or DMX takes precedence.

If the dimmer is in **Network Mode**, you can also turn the selected DMX Input mode for the dimmer, on or off for each **area** defined on the dimmer.

If the DMX Input is **enabled**, you can select the DMX Fail Mode, that is, choose what happens to the dimmer outputs if the DMX input signal fails (Hold DMX, Fade to Black or Fade to Memory).

When the DMX Input is disabled, any DMX input signal is ignored.

## DMX Disabled

Any DMX Input is ignored by the dimmer. The outputs are determined by the manual control and memory or sequence levels only, which are HTP mixed together.

## DMX HTP Mix

The DMX Input signal is mixed on a HTP (highest takes precedence) basis with the manual control and memory or sequence levels to give the final output levels.

## DMX Takes Precedence

When the DMX Input signal is **available**, it takes precedence over the manual control and memory/sequence levels - the outputs go to the DMX Input levels.

When the DMX Input signal is **not available**, the outputs are determined by the manual control and memory or sequence levels which are HTP mixed.

## DMX Input - Stand Alone

Select the *DMX Input* option from the menu, and press the ENT key. The screen shows the current setting for the dimmer, for example:

< DMX DISABLED >

Use the cursor keys to set the DMX input to the required option (DMX DISABLED, DMX HTP MIX, or DMX PRECEDENCE).

Press the ENT key to confirm the DMX Input selection.

If DMX DISABLED was selected, the screen returns to the *DMX Input* screen, otherwise the screen shows:

DMX FAIL MODE  
< Hold DMX >

Select the required DMX fail Mode as follows:

**Hold DMX** - Use cursor keys to select this option. Press the ENT key.

**Fade to Black** - Use cursor keys to select this option. Press the ENT key.

**Fade to Memory** - Use cursor keys to select this option. The screen shows:

```
DMX FAIL MODE
<Fade to Mem:xx>
```

Use the numeric keypad to enter the required memory number, then press the ENT key.

After selecting the required fail mode and pressing the ENT key, the screen returns to the *DMX Input* screen.

## DMX Input - Network Mode

Select the *DMX Input* option from the menu, and press the ENT key. The screen shows the current setting for the dimmer, for example:

```
< DMX DISABLED >
```

Use the cursor keys to set the DMX input to the required option (DMX DISABLED, DMX HTP MIX or DMX PRECEDENCE).

Press the ENT key to confirm the DMX Input selection.

If DMX DISABLED was selected, the screen returns to the *DMX Input* screen, otherwise the screen shows:

```
Area: 1
DMX: ON
```

This screen allows you to turn the selected DMX Input Mode on or off for each area defined on the dimmer.

The cursor is shown in the *Area* field. Use the numeric keypad or cursor keys to select an area, then press the ENT key.

If the selected area is valid, the cursor moves to the *DMX* field.

Use the cursor keys to select On or Off as required. Press the ENT key. The cursor returns to the *Area* field.

Repeat the operation for each area defined on the dimmer.

Press the ESC key to move on to the DMX Fail Mode screen:

```
DMX FAIL MODE
< Hold DMX >
```

This screen allows you to set the DMX Fail Mode for the dimmer.

Select the required DMX Fail Mode for the area as follows:

**Hold DMX** - Use cursor keys to select this option. Press the ENT key.

**Fade to Black** - Use cursor keys to select this option. Press the ENT key.

**Fade to Memory** - Use cursor keys to select this option. The screen shows:

```
DMX FAIL MODE
<Fade to Mem:xx>
```

Use the numeric keypad to enter the required memory number, then press the ENT key.

After selecting the fail mode, the screen returns to the *DMX Input* screen.

## Notes - DMX Fail Modes

### Hold DMX

In HTP Mix mode, the last DMX input levels are held in the dimmer and mixed in as normal.

In DMX Precedence mode, the DMX inputs are removed from the output calculations.

### Fade To Black

The DMX Input values and any memory or sequence being output are faded to black (0%) over 3 seconds.

### Fade To Memory

If the dimmer is not outputting a memory or sequence, the outputs fade to the specified backup memory. If the dimmer is outputting the backup memory, the outputs fade to that memory. If the dimmer is outputting a **different** memory or sequence, the outputs will fade or snap to the memory or sequence.

### In Stand Alone Mode

The above statements apply to all dimmer channels.

### In Network Mode

the above statements are applied to the channels on an area basis, since each area could be outputting a different memory or sequence at the time of DMX failure.

## RDM

Select the *RDM* option from the menu, and press the ENT key. The screen shows the current setting for the dimmer, for example:

```
< RDM Control >
RDM is On
```

Use the cursor keys to alter this setting between *On* and *Off*, to enable or disable the DMX RDM (Remote Device Management) functionality of the Chilli Dimmer.

## Security

This option allows you to lock the dimmer, disabling all menu access. The dimmer is locked and unlocked manually by entering a four digit code.

### Global Unlock Code

There is also a global unlock code which will unlock the Chilli Dimmer.

Contact Zero 88 or your dealer for further information.

## Networked Dimmers

A networked dimmer can be locked locally as described in this section.

This will **not** prevent the dimmer from being controlled from a Chilli Master Controller or Chilli control panels connected to the network.

A networked dimmer can also be locked and unlocked from a Chilli Master Controller.

### Locking the Dimmer

Select the *Security* option from the top level options menu, and press the ENT key. The screen shows:

Lock Dimmer  
Code: xxxx

Use the numeric keypad to enter a 4 digit code and then press the ENT key. The screen shows:

Confirm Code  
Code: xxxx

Re-enter the same 4 digit code and then press the ENT key to confirm.

If the codes match - the dimmer is locked, the screen returns to the main screen, and all menu access is disabled.

If the codes do not match - an error message is briefly shown, and the screen returns to the *Lock Dimmer* screen above.

### Unlocking the Dimmer

If the dimmer is locked, the main screen will be shown, and all menu access will be disabled.

If the ENT key is pushed in order to gain access to the menus, the screen shows:

Dimmer Locked  
Code: xxxx

Enter the 4 digit code using the numeric keypad, and then press the ENT key.

If the correct code is entered - the dimmer is unlocked, and the screen shows the first screen in the top level menu structure (Manual Control).

If an incorrect code is entered - an error message is briefly shown and the screen returns to the main screen.

### Note - Unlocking the Dimmer

*If the code to unlock the dimmer has been forgotten, contact Zero 88 Technical Support who will supply a master unlock code.*

## Chilli Net

This option puts the dimmer into **Network Mode** so that it can be controlled remotely by a Chilli Master Controller, Chilli Control Panels or other Chilli Dimmers on the network via Chilli Net messages.

For the network to function correctly each dimmer on the network must have a **unique** dimmer number.

Select the *Chilli Net* option from the top level options menu, and press the ENT key. The screen shows:

State: Disabled  
Dimmer No: xxx

The cursor is in the *State* field. Use the cursor keys to select Enabled. Press the ENT key to move the cursor to the *Dimmer No* field:

State: Enabled  
Dimmer No: xxx

Enter the dimmer number using the numeric keypad or cursor keys. Press the ENT key to confirm.

The dimmer number is checked against other dimmers on the network. The screen shows:

Verifying  
Dimmer No

If the dimmer number is valid, the screen will briefly show:

Dimmer No  
Accepted

If the dimmer number is already used on the network, the screen will briefly show:

Dimmer No  
Already Used

## Area Control

This option is only available when the dimmer is in **Network Mode**. This option allows you to assign each of the dimmer channels to an Area (1 - 10).

Select the *Area Control* option from the top level menu options, and press the ENT key to enter the Area Control menu.

The following options are available:

- Set Chan Area
- Set All Chans

### Set Channel Area

This option allows you to assign an area to each of the dimmer channels individually.

Select the *Set Chan Area* option from the menu, and press the ENT key. The screen shows:

```
Channel: 1
Area: 1
```

The cursor is in the *Channel* field. Press the ENT key to move between the *Channel* and *Area* fields, and adjust the values using the cursor keys and numeric keypad.

Repeat operation for each channel.

## Set All Channels

This option allows you to assign an area to all the channels on the dimmer in a single operation.

Select the *Set All Chans* option from the menu, and press the ENT key. The screen shows:

```
All Channels
Area: 1
```

Use the numeric keypad or cursor keys to enter the required area number (1-10) and then press the ENT key.

## Alarm Input

The Chilli Dimmer has an alarm input, which when activated, causes it to enter an alarm state.

If the dimmer is networked, it will also send out alarm messages to ensure that all other devices on the network also enter the alarm state.

## Alarm Input Active

When the dimmer's Alarm Input is **activated**, the following will occur:

- The dimmer enters the Alarm State.
- All channel output levels fade to 80% over a period of 1s (see note).
- All menu access via the control panel is disabled.
- The screen shows:

```
DIMMER LOCKED
* ALARM ACTIVE *
```

- If the dimmer is in Network Mode it sends out an Alarm On message.
- The Alarm On message is repeated every 5 seconds while the Alarm Input remains active.

## Alarm Input Inactive

When the dimmer's Alarm Input changes from **active to inactive**, the following will occur:

- The dimmer exits the Alarm State.
- All output channels fade to their normal levels over a period of 1s.
- All menu access via the control panel is enabled.
- The screen shows the main screen.
- If the dimmer is in Network Mode it sends out an Alarm Off message.

## Alarm On Message

When a networked dimmer receives an **Alarm On message**, the following will occur:

- The dimmer enters the Alarm State.
- All channel output levels fade to 80% over a period of 1s (see note).
- All menu access via the control panel is disabled.
- The screen shows:

```
DIMMER LOCKED
* ALARM ACTIVE *
```

## Alarm Off Message

When a networked dimmer receives an Alarm Off message and its Alarm Input is not active, the following will occur:

- The dimmer exits the Alarm State.
- All output channels fade to their normal levels over a period of 1s.
- All menu access via the control panel is enabled.
- The screen shows the main screen.

## Notes

### Alarm State - Output Levels

When the dimmer is in the Alarm State, the output levels are subject to topset, but **not** temperature shutdown. Manual control levels, memories, sequences, preheat and DMX inputs do **not** have any contribution to the final output levels.

### Alarm State on Power Up

On power up, the alarm state of the dimmer is determined by the alarm input **only**, ie it does not remember any alarm messages previously received.

## Technical Specification

### Electrical

Supply Voltage:  
230V +10% / -15%

Supply Frequency:  
45 to 65Hz

Maximum Supply Current:  
 0410i: 40A Single phase  
 0410HF: 40A Single phase  
 1210i: 40A 3 phase star  
 1210HF: 40A 3 phase star  
 1216i: 64A 3 phase star  
 2410i: 80A 3 phase star  
 2410i 1212: 80A per phase  
 2410i Bypass: 80A per phase  
 2416i: 128A 3 phase star  
 2416i 1212: 128A per phase  
 2416i Bypass: 128A per phase  
 625i: 50A 3 phase star

Maximum Load per Channel  
 0410i: 10A Max  
 0410HF: 10A Max  
 1210i: 10A Max  
 1210HF: 10A Max  
 1216i: 16A Max  
 2410i: 10A Max  
 2410i 1212: 10A Max  
 2410i Bypass: 10A Max  
 2416i: 16A Max  
 2416i 1212: 16A Max  
 2416i Bypass: 10A Max  
 625i: 25A Max

DMX Input:  
USITT DMX512/1990  
Ground referenced receiver  
Internal switchable termination

### RDM Support:

Protocol Version:  
1.0

Device Model ID:  
The first 5 digits of the stock number are used for this, e.g. 01105 (0x0451) for the Chilli Pro 1210i.

Supported Parameters:  
*DMX\_START\_ADDRESS,*  
*SENSOR\_DEFINITION,*  
*SENSOR\_VALUE,*  
*DEVICE\_LABEL,*  
*MANUFACTURER\_LABEL,*  
*DEVICE\_MODEL\_DESCRIPTION*

Sub Devices:  
One per channel.

### Mechanical

Size:  
 0410i: 400 x 220 x 155 mm  
 0410HF: 400 x 220 x 155 mm  
 1210i: 850 x 325 x 155 mm  
 1210HF: 550 x 220 x 155 mm  
 1216i: 850 x 325 x 155 mm  
 2410i: 1000 x 632 x 155 mm  
 2410i 1212: 1000 x 632 x 155 mm  
 2410i Bypass: 1000 x 632 x 155 mm  
 2416i: 1000 x 632 x 155 mm  
 2416i 1212: 1000 x 632 x 155 mm  
 2416i Bypass: 1000 x 632 x 155 mm  
 625i: 850 x 325 x 155 mm

Maximum Weight:  
 0410i: 7.0 Kg  
 0410HF: 4.0 Kg  
 1210i: 18.0 Kg  
 1210HF: 9.0 Kg  
 1216i: 24.0 Kg  
 2410i: 47.0 Kg  
 2410i 1212: 47.0 Kg  
 2410i Bypass: 47.0 Kg  
 2416i: 50.0 Kg  
 2416i 1212: 49.5 Kg  
 2416i Bypass: 49.5 Kg  
 625i: 26.5 Kg

### Environmental

Operating Temperature Range:  
+5°C to +40°C

Relative Humidity:  
5% to 95% Non-condensing

### EMC

Emissions:  
 EN55015 : 2000  
 +A1 : 2001  
 +A2 : 2002

Immunity:  
 EN61000-6-1 : 2001  
 EN61000-6-3 : 2001

Electrical Safety:  
 EN60950-1 : 2002

### Notes

Zero 88 Ltd reserves the right to make changes to the equipment described in this manual without prior notice. (E&OE).

© Zero 88 Ltd (2014)