

Super High Voltage (SHV)

2220SV431-501A

● **OUTLINE DIMENSIONS**

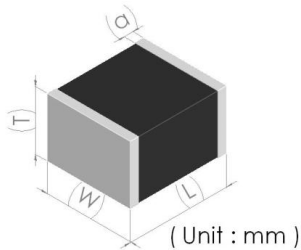

Model	2220
Length(L)	6.00 +0.7/ -0.3mm
Width(W)	5.30 +0.5/ -0.3mm
Thickness(T)	3.60 mm Max
Termination(a)	0.50 +0.35/ -0.1mm

1. Features of SHV Series

1. RoHS compliant
2. SMD type Body size 2220
3. Meet IEC61000-4-5 and UL 1449 Standard
4. Bidirectional and symmetrical V/I characteristics
5. Large withstanding surge current capability : 500A (@8/20μs)
6. Excellent low leakage current <20μA
7. Operating temperature range : -40 ~ +85 °C
8. Multi-Layers construction provides higher power dissipation

- ☆L **Body Inductance**
- ☆C **Device Capacitance**
- ☆VR **Voltage Variable Resistor**
- ☆R **Insulation Resistor**
- ☆Diode **Voltage clamped**
- ☆PTC **For low leakage current**

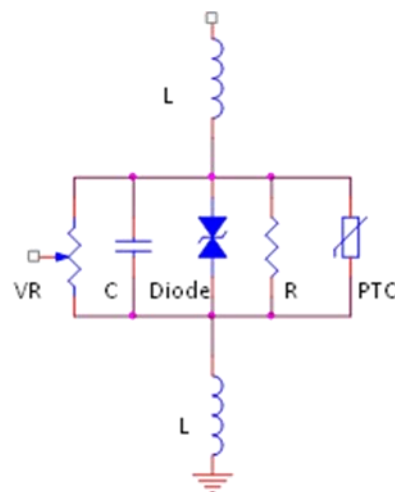

Super High Voltage (SHV)
2220SV431-501A

2.1 Technology Data	Symbol	Value	Unit
Maximum allowable continuous AC voltage at 50-60 Hz	V_{RMS}	275	V
Maximum allowable continuous DC voltage	V_{DC}	350	V
Breakdown voltage	V_B	430±10%)	V
Maximum allowable clamping voltage	V_C	705	V
Maximum peak current (8/20 μ s) (1 time)	I_{Peak}	500	A
Maximum peak current (8/20 μ s) (15 time)	I_{Peak}	250	A

2.2 Reference Data	Symbol	Value	Unit
Typical capacitance value measured at 1KHz	C	215	pF
Response time	T_{rise}	< 1	ns
Non-linear coefficient		> 20	
Leakage current at $V_B \times 80\%$ (at initial state)	I_{VB}	< 20	μ A
Leakage current at $V_B \times 80\%$ (after surge test)	I_{VBA}	< 100	μ A
Operation ambient temperature	T_{OPT}	-40 ~ +85	
Storage temperature range	T_{STG}	-40 ~ +125	

2.3 Other Data	Symbol	Value	Unit
Body		Nano Special Ceramic	
End termination		Ag/Ni/Sn	
Packaging		Reel	
Complies with Standard		IEC61000-4-5 UL 1449, File No. E334409-VZCA2	
Complies with RoHs Standard		Yes	
Lead Content		< 1000	ppm
Marking		None	

Notes :

- * 1 The breakdown voltage was measured at 1 mA current.
- * 2 The Clamping voltage was measured at 8/20 μ s standard current, 2220(10A).
- * 3 The surge current was tested at 8/20 μ s waveform.
- * 4 The capacitance value only for customer reference, it's not formal specification.
- * 5 The components shall be employed within 1 year, in the nitrogen condition.

Super High Voltage (SHV)

2220SV431-501A

3. Surge Wave Form

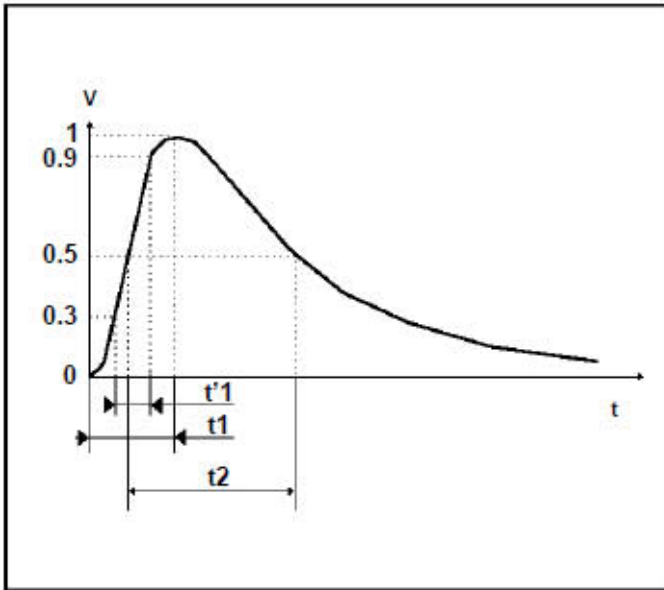

8/20us waveform current

IEC61000-4-5 Standards

SEVERITY LEVEL	t1 (=1.67t'1)	t2
1	10 μs	1000 μs
2	8 μs	20 μs

4. Recommended solder pad layout

(Unit : mm)

	A	B	C
2220	4.1~4.9	1.4~2.2	5.6~6.4

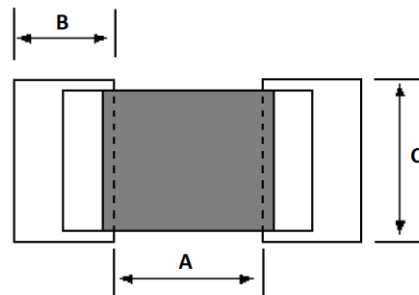

Super High Voltage (SHV)
2220SV431-501A

5. Packaging Specification

- 5.1 Carrier tape and transparent cover tape should be heat-sealed to carry the products, and the reel should be used to reel the carrier tape.
- 5.2 The adhesion of the heat-sealed cover tape shall be 40 +20/-15 grams.
- 5.3 Both the head and the end portion of the taping shall be empty for reel package and SMT auto-pickup machine. And a normal paper tape shall be connected in the head of taping for the operator to handle.

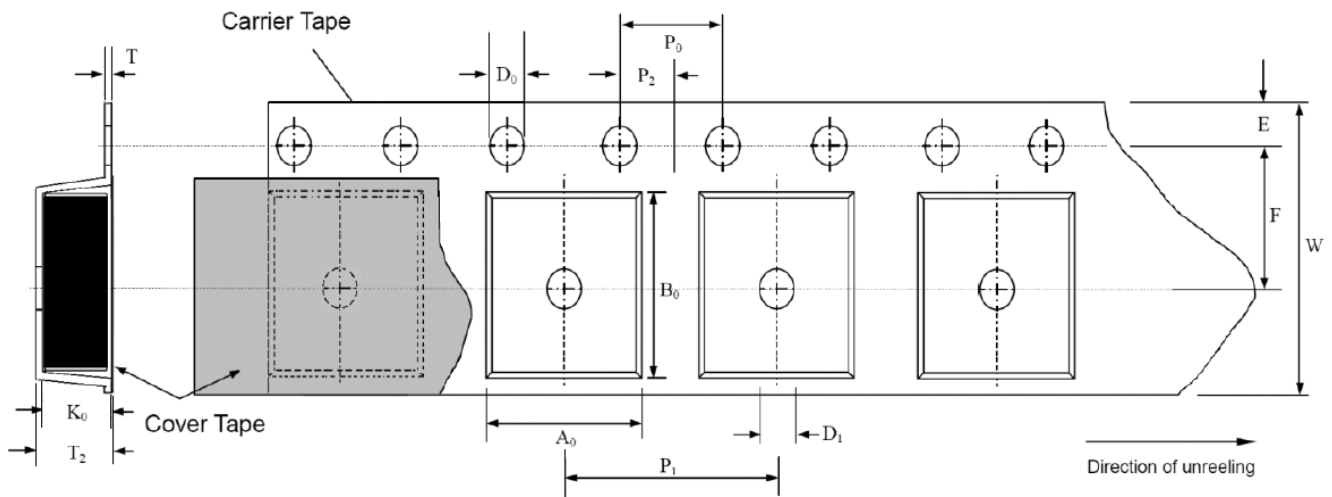

(Unit : mm)

Symbol	A ₀ ±0.10	B ₀ ±0.10	K ₀ ±0.10	T ±0.05	T ₂ ±0.05	D ₀ +0.10 -0.00	D ₁ ±0.05	P ₁ ±0.10	P ₂ ±0.05	P ₀ ±0.05	W ±0.20	E ±0.10	F ±0.05
2220	5.90	6.80	3.75	0.25	3.95	1.50	1.50	8.00	2.00	4.00	12.00	1.75	5.50

Super High Voltage (SHV)

2220SV431-501A

6. Reel Dimension

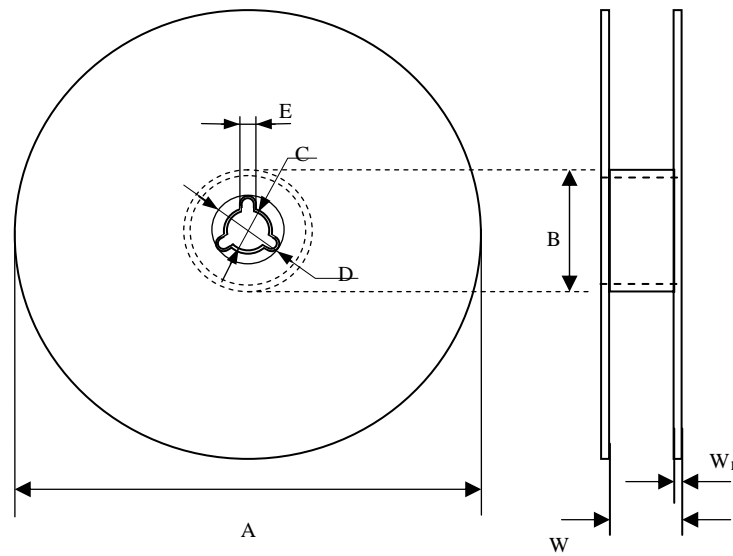

Unit(mm)

Symbol	A	B	C	D	E	W	W ₁
2220	178.0±1.0	60.0±0.5	13.5±0.1	21.0±0.2	2.0±0.5	13.6±0.2	1.5±0.1

7. Standard packaging

Size	2220
Pcs	500