

REVISIONS			
REV	DESCRIPTION	DATE	APPV
A	INITIAL RELEASE OF INTERNAL DOCUMENT	6-FEB-12	SAH
B	UPDATED AND REPOSITIONED LOGO, ADDED PART NUMBER TABLE	26-JUN-12	SAH

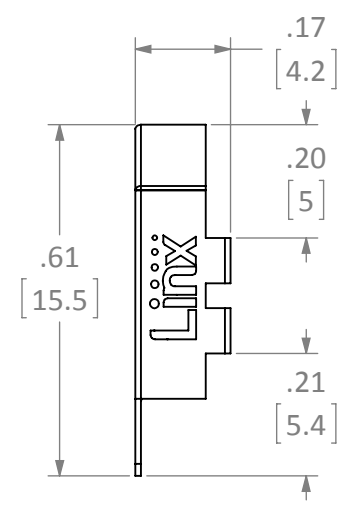

RECOMMENDED FOOTPRINT

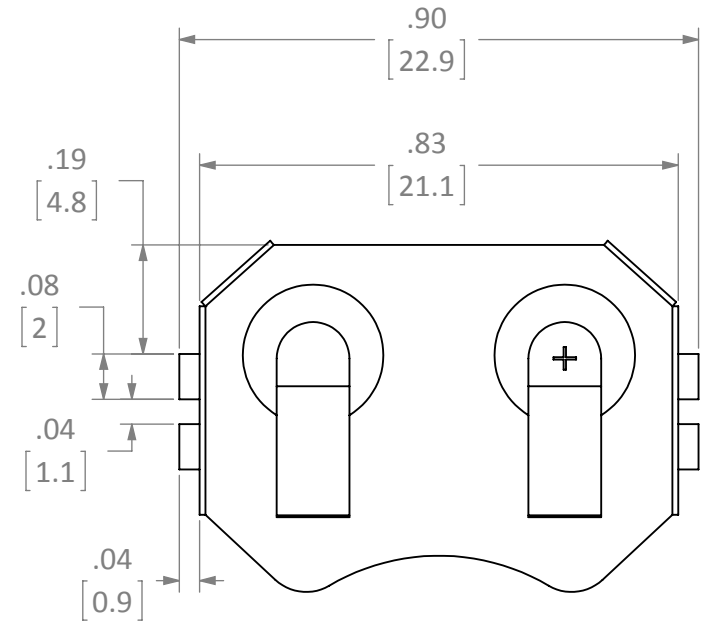
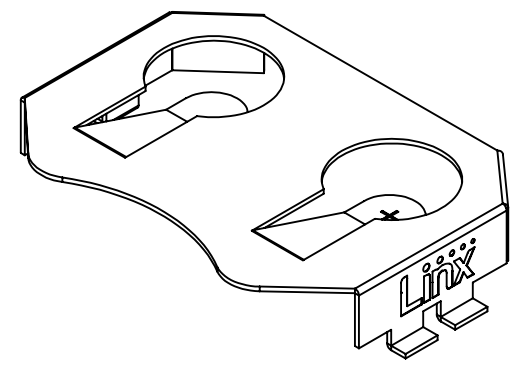
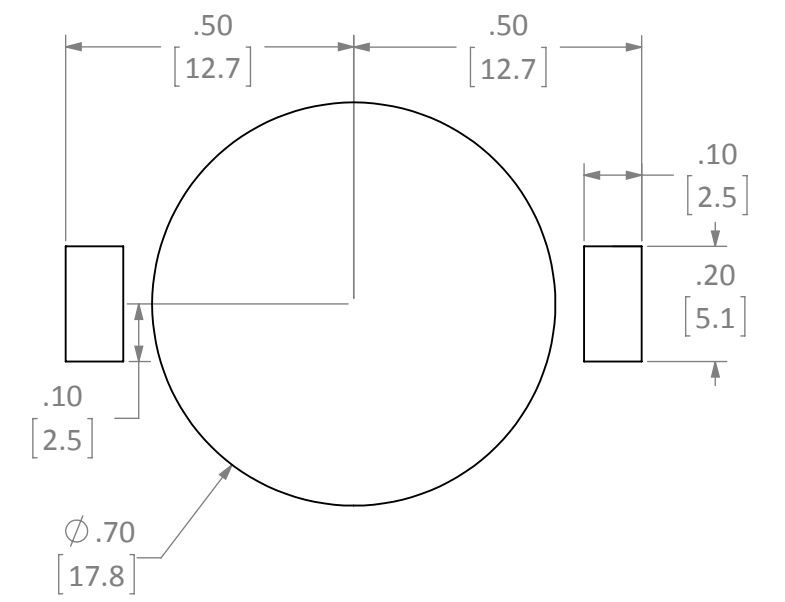

- NOTES: (UNLESS OTHERWISE SPECIFIED)
1. ALL DIMENSIONS ARE IN INCHES [mm].
 2. DIMENSIONS APPLY AFTER FINISHING.
 3. MANUFACTURE TO BE COMPLIANT WITH EU RoHS DIRECTIVE.
 4. SAFETY BREAK ALL SHARP CORNERS AND EDGES .02 MAXIMUM.

PART NUMBER	LOGO	PACKAGING
BAT-HLD-001	YES	BULK
BAT-HLD-001-NO	NO	BULK
BAT-HLD-001-TR	YES	TAPE & REEL

WARNING: THIS DRAWING CONTAINS PROPRIETARY INFORMATION THAT IS THE SOLE PROPERTY OF LINX TECHNOLOGIES, AND SHALL BE TREATED AS SUCH. NO DISCLOSURE OR REPRODUCTION OF THIS DOCUMENT IS PERMITTED, IN WHOLE OR IN PART, WITHOUT THE EXPRESS WRITTEN PERMISSION OF LINX TECHNOLOGIES OR ITS DESIGNATED AGENTS.

MATERIAL:
PHOSPHOR BRONZE
#C-5191

FINISH:
NICKEL PLATE

INTERPRET DIMENSIONS AND TOLERANCES PER ASME Y14.5.
SURFACE FINISH: $\sqrt{}$ ANGLES: $\pm 1^\circ$
TOLERANCES: .X \pm .1 .XX \pm .01 .XXX \pm .005

DRAWN: B.MURPHY DT: 25-MAY-12
ENGR: S.HOGAN DT: 25-MAY-12

Linx 159 ORT LANE
MERLIN, OR 97532

TITLE:
**BATTERY HOLDER OUTLINE
CR2032, CR2025 SURFACE MOUNT**

SIZE DWG. NO. REV
B BAT-HLD-001-xx-OTL **B**

SCALE: 3:1 DO NOT SCALE DRAWING SHEET 1 OF 1

8 7 6 5 4 3 2 1

D

D

C

C

B

B

A

A

8 7 6 5 4 3 2 1 LDCDFB_C