

DG180-191 High-Speed Driver With Junction FET Switches

FEATURES

- Constant ON-resistance for signals to $\pm 10V$ (DG182, 185, 188, 191), to $\pm 7.5V$ (all devices)
- $\pm 15V$ power supplies
- $< 2nA$ leakage from signal channel in both ON and OFF states
- TTL, DTL, RTL direct drive compatibility
- $t_{on}, t_{off} < 150ns$, break-before-make action
- Cross-talk and open switch isolation $> 50dB$ at 10MHz (75 Ω load)

GENERAL DESCRIPTION

The DG180 thru DG191 series of analog gates consists of 2 or 4 N-channel junction-type field-effect transistors (J-FET) designed to function as electronic switches. Level-shifting drivers enable low-level inputs (0.8 to 2V) to control the ON-OFF state of each switch. The driver is designed to provide a turn-off speed which is faster than turn-on speed, so that break-before-make action is achieved when switching from one channel to another. In the ON state, each switch conducts current equally well in both directions. In the OFF condition, the switches will block voltages up to 20V peak-to-peak. Switch-OFF input-output feedthrough is $> 50dB$ down at 10MHz, because of the low output impedance of the FET-gate driving circuit.

SCHEMATIC DIAGRAM (Typical Channel)

ONE AND TWO CHANNEL SPDT AND SPST
CIRCUIT CONFIGURATION

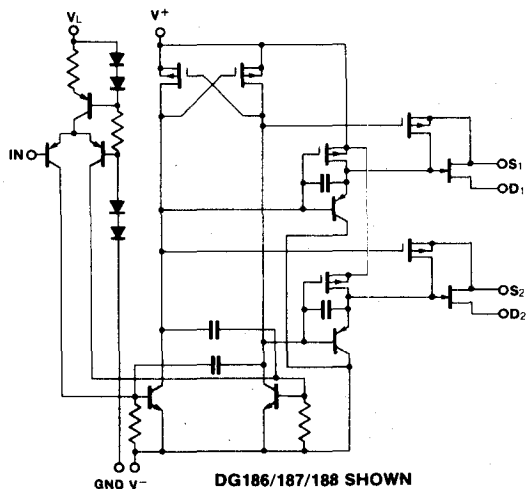

TWO CHANNEL DPST CIRCUIT CONFIGURATION

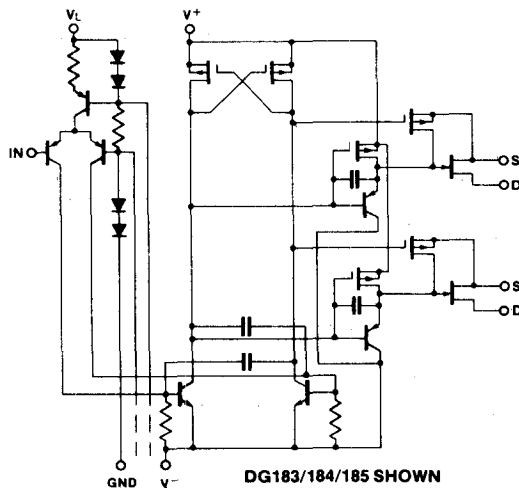

ORDERING INFORMATION

PART NUMBER	TYPE	$r_{DS(on)}$ (MAX)
DG180	Dual SPST	10
DG181	Dual SPST	30
DG182	Dual SPST	75
DG183	Dual DPST	10
DG184	Dual DPST	30
DG185	Dual DPST	75
DG186	SPDT	10
DG187	SPDT	30
DG188	SPDT	75
DG189	Dual SPDT	10
DG190	Dual SPDT	30
DG191	Dual SPDT	75

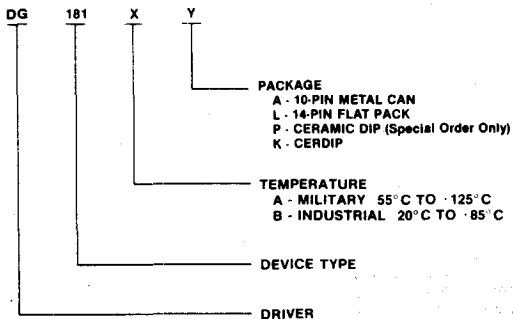

3

