

## DG180-191 High-Speed Driver With Junction FET Switches

### FEATURES

- Constant ON-resistance for signals to  $\pm 10V$  (DG182, 185, 188, 191), to  $\pm 7.5V$  (all devices)
- $\pm 15V$  power supplies
- $< 2nA$  leakage from signal channel in both ON and OFF states
- TTL, DTL, RTL direct drive compatibility
- $t_{on}, t_{off} < 150ns$ , break-before-make action
- Cross-talk and open switch isolation  $> 50dB$  at 10MHz (75 $\Omega$  load)

### GENERAL DESCRIPTION

The DG180 thru DG191 series of analog gates consists of 2 or 4 N-channel junction-type field-effect transistors (J-FET) designed to function as electronic switches. Level-shifting drivers enable low-level inputs (0.8 to 2V) to control the ON-OFF state of each switch. The driver is designed to provide a turn-off speed which is faster than turn-on speed, so that break-before-make action is achieved when switching from one channel to another. In the ON state, each switch conducts current equally well in both directions. In the OFF condition, the switches will block voltages up to 20V peak-to-peak. Switch-OFF input-output feedthrough is  $> 50dB$  down at 10MHz, because of the low output impedance of the FET-gate driving circuit.

### SCHEMATIC DIAGRAM (Typical Channel)

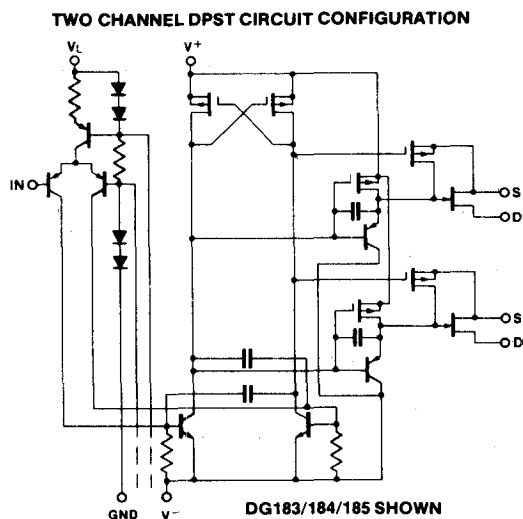
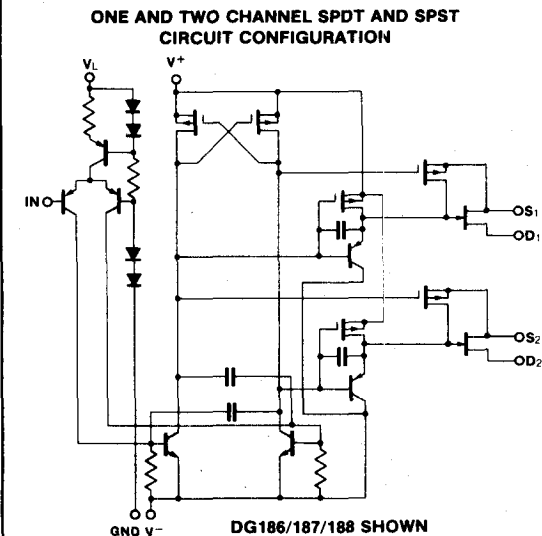

### ORDERING INFORMATION

PART NUMBER	TYPE	$r_{DS(on)}$ (MAX)
DG180	Dual SPST	10
DG181	Dual SPST	30
DG182	Dual SPST	75
DG183	Dual DPST	10
DG184	Dual DPST	30
DG185	Dual DPST	75
DG186	SPDT	10
DG187	SPDT	30
DG188	SPDT	75
DG189	Dual SPDT	10
DG190	Dual SPDT	30
DG191	Dual SPDT	75

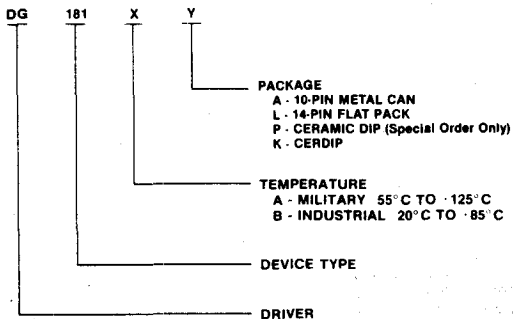

3

**ELECTRICAL CHARACTERISTICS (CONT'D)**  
 MAXIMUM RESISTANCES (r<sub>DS(ON)</sub> MAX)

DEVICE NUMBER	MILITARY TEMPERATURE			INDUSTRIAL TEMPERATURE			UNITS	CONDITIONS (Note 1)	
	-55°C	+25°C	+125°C	-20°C	+25°C	+85°C		V <sub>D</sub> = 15V, V <sub>S</sub> = -15V, V <sub>L</sub> = 5V	
DG180	10	10	20	15	15	25	Ω	V <sub>D</sub> = -7.5V	I <sub>S</sub> = -10mA  V <sub>IN</sub> = "ON"
DG181	30	30	60	50	50	75	Ω	V <sub>D</sub> = -7.5V	
DG182	75	75	100	100	100	150	Ω	V <sub>D</sub> = -10V	
DG183	10	10	20	15	15	25	Ω	V <sub>D</sub> = -7.5V	
DG184	30	30	60	50	50	75	Ω	V <sub>D</sub> = -7.5V	
DG185	75	75	150	100	100	150	Ω	V <sub>D</sub> = -10V	
DG186	10	10	20	15	15	25	Ω	V <sub>D</sub> = -7.5V	
DG187	30	30	60	50	50	75	Ω	V <sub>D</sub> = -7.5V	
DG188	75	75	150	100	100	150	Ω	V <sub>D</sub> = -10V	
DG189	10	10	20	15	15	25	Ω	V <sub>D</sub> = -7.5V	
DG190	30	30	60	50	50	50	Ω	V <sub>D</sub> = -7.5V	
DG191	75	75	150	100	100	150	Ω	V <sub>D</sub> = -10V	

**APPLICATION HINT** (for design only): Normally the minimum signal handling capability of the DG180 through DG191 family is 20V peak-to-peak for the 75Ω switches and 15V peak-to-peak for the 10Ω and 30Ω switches (refer I<sub>D</sub> and I<sub>S</sub> tests above). For other Analog Signals, the following guidelines can be used: proper switch turn-off requires that V<sub>S</sub> ≤ V<sub>ANALOG(peak)</sub> - V<sub>D</sub> where V<sub>D</sub> = 7.5V for the 10Ω and 30Ω switches and V<sub>D</sub> = 5.0V for 75Ω switches e.g., -10V minimum (-peak) analog signal and a 75Ω switch (V<sub>D</sub> = 5V), requires that V<sub>S</sub> ≤ -10V - 5V = -15V.

3

**SWITCHING TIME TEST CIRCUIT**

Switch output waveform shown for V<sub>S</sub> = constant with logic input waveform as shown. Note that V<sub>S</sub> may be + or - as per

switching time test circuit. V<sub>D</sub> is the steady state output with switch on. Feedthrough via gate capacitance may result in spikes at leading and trailing edge of output waveform.

LOGIC INPUT FOR "OFF" TO "ON" CONDITION (DG180/181/182 SHOWN)

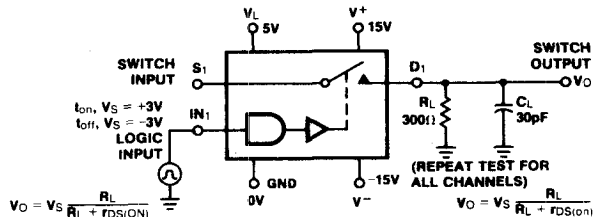
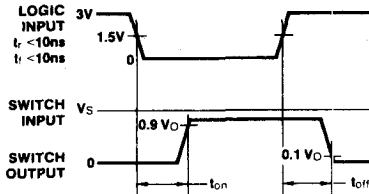

**DUAL SPST**  
 DG180/181/182

**DUAL DPST**  
 DG183/184/185

**SPDT**  
 DG186/187/188

**DUAL SPDT**  
 DG189/190/191

TEST CONDITIONS	
DG180/181/182	
V <sub>IN</sub> "ON" = 0.8V	All Channels
V <sub>IN</sub> "OFF" = 2.0V	All Channels

TEST CONDITIONS	
DG183/184/185	
V <sub>IN</sub> "ON" = 2.0V	All Channels
V <sub>IN</sub> "OFF" = 0.8V	All Channels

TEST CONDITIONS	
DG186/187/188	
V <sub>IN</sub> "ON" = 2.0V	Channel 1
V <sub>IN</sub> "ON" = 0.8V	Channel 2
V <sub>IN</sub> "OFF" = 2.0V	Channel 2
V <sub>IN</sub> "OFF" = 0.8V	Channel 1

TEST CONDITIONS	
DG189/190/191	
V <sub>IN</sub> "ON" = 2.0V	Channels 1 & 2
V <sub>IN</sub> "ON" = 0.8V	Channels 3 & 4
V <sub>IN</sub> "OFF" = 2.0V	Channels 3 & 4
V <sub>IN</sub> "OFF" = 0.8V	Channels 1 & 2

SWITCH STATES ARE FOR LOGIC "1" INPUT = 2.0V

SWITCH STATES ARE FOR LOGIC "1" INPUT = 2.0V

SWITCH STATES ARE FOR LOGIC "1" INPUT = 2.0V

SWITCH STATES ARE FOR LOGIC "1" INPUT = 2.0V