

## FEATURES

- Improved Specifications Compared to LF155/156 Devices
- *Guaranteed* Low Offset Voltage 500 $\mu$ V Max.
- *Guaranteed* Low Offset Drift 5 $\mu$ V/ $^{\circ}$ C Max.
- *Guaranteed* Bias Current Fully Warmed-Up over Temperature
- OP-15: LF156 Speed with LF155 Power Dissipation
  - Guaranteed* Supply Current 4mA Max.
  - Guaranteed* Slew Rate 10V/ $\mu$ s Min.
- OP-16:
  - Guaranteed* Faster Slew Rate 18V/ $\mu$ s Min.
  - No High Frequency Oscillation at Cold Temperatures
- No Phase Reversal when Negative Common-Mode Limit is Exceeded

## APPLICATIONS

Long Term Precision Integration  
 Current to Voltage Conversion  
 Medical Instrumentation—CAT Scanner  
 High Speed, Precision Sample and Hold

## DESCRIPTION

The OP-15/16 series devices feature distinct advantages over other JFET-input operational amplifiers, in particular compared to LF155/156 types.

The OP-15 has the speed of the LF156 design with the low power dissipation of the slower LF155. The OP-16 is considerably faster. Both devices offer offset voltages as low as 0.5mV, with guaranteed drift of 5 $\mu$ V/ $^{\circ}$ C. Input bias current at 125 $^{\circ}$ C is just a few nanoamperes.

Other manufacturers' OP-15/16 (and LF155/156) exhibit phase reversal at the output when the negative common-mode limit at the input is exceeded; i.e., driving from -12V to -15V with  $\pm$ 15V supplies. This can cause lock-up in servo systems. As shown in the application section, Linear Technology's OP-15/16 does not have this problem due to unique phase reversal protection circuitry.

In addition, Linear's OP-16 is free from high frequency oscillation problems at cold temperatures, as is illustrated in the "Voltage Follower Small Signal Pulse Response" photo. For applications requiring higher performance, see the LT1022, LT1055 and LT1056 data sheets.

Fast, 12-Bit Current Comparator

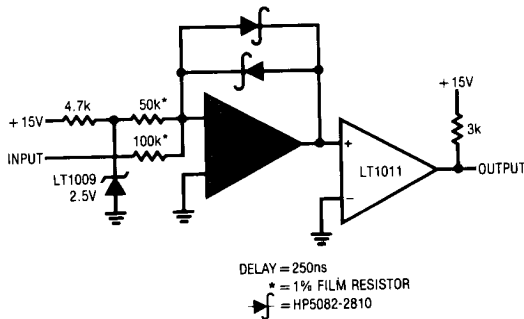

Voltage Follower Small Signal Pulse Response  
 $T_A = -55^{\circ}\text{C}$

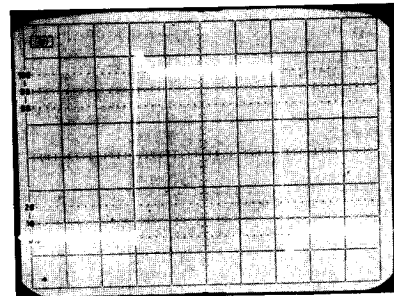

$C_1 = 100\text{pF}$   
 VERTICAL SCALE = 20mV/DIV  
 HORIZONTAL SCALE = 0.2 $\mu$ s/DIV

**ABSOLUTE MAXIMUM RATINGS**

Supply Voltage  
 A, B, E, F Grades . . . . . ± 22V  
 C, G Grades . . . . . ± 18V  
 Internal Power Dissipation . . . . . 500mW  
 Operating Temperature Range  
 A, B, C Grades . . . . . -55°C to 125°C  
 E, F, G Grades . . . . . 0°C to 70°C  
 Junction Temperature . . . . . 150°C  
 Differential Input Voltage  
 A, B, E, F Grades . . . . . ± 40V  
 C, G Grades . . . . . ± 30V  
 Input Voltage (Note 4)  
 A, B, E, F Grades . . . . . ± 20V  
 C, G Grades . . . . . ± 16V  
 Output Short Circuit Duration . . . . . Indefinite  
 Storage Temperature Range . . . . . -65°C to 150°C  
 Lead Temperature (Soldering, 10 sec.) . . . . . 300°C

**PACKAGE/ORDER INFORMATION**

TOP VIEW		ORDER PART NUMBER	
		OP-15AH	OP-16AH
		OP-15BH	OP-16BH
		OP-15CH	OP-16CH
		OP-15EH	OP-16EH
		OP-15FH	OP-16FH
		OP-15GH	OP-16GH
		OP-15GN8	OP-16GN8
		V <sub>OS</sub> is adjusted with a potentiometer ranging from 10k to 1M. The wiper is connected to V <sup>+</sup>	

**ELECTRICAL CHARACTERISTICS** V<sub>S</sub> = ± 15V, T<sub>A</sub> = 25°C unless otherwise noted.

SYMBOL	PARAMETER	CONDITIONS	OP-15A/E OP-16A/E			OP-15B/F OP-16B/F			OP-15C/G OP-16C/G			UNITS
			MIN	TYP	MAX	MIN	TYP	MAX	MIN	TYP	MAX	
V <sub>OS</sub>	Input Offset Voltage	R <sub>S</sub> = 50Ω	—	0.2	0.5	—	0.4	1.0	—	0.5	3.0	mV
I <sub>OS</sub>	Input Offset Current	T <sub>I</sub> = 25°C (Note 1) Warmed-Up OP-15 OP-16	—	3	10	—	6	20	—	12	50	pA
			—	5	22	—	10	40	—	20	100	pA
			—	5	25	—	10	50	—	20	125	pA
I <sub>B</sub>	Input Bias Current	T <sub>I</sub> = 25°C (Note 1) Warmed-Up OP-15 OP-16	—	± 15	± 50	—	± 30	± 100	—	± 60	± 200	pA
			—	± 18	± 110	—	± 40	± 200	—	± 80	± 400	pA
			—	± 20	± 130	—	± 40	± 250	—	± 80	± 500	pA
R <sub>IN</sub>	Input Resistance		—	10 <sup>12</sup>	—	—	10 <sup>12</sup>	—	—	10 <sup>12</sup>	—	Ω
A <sub>VOL</sub>	Large Signal Voltage Gain	R <sub>L</sub> ≥ 2kΩ V <sub>O</sub> = ± 10V	100	240	—	75	220	—	50	200	—	V/mV
V <sub>O</sub>	Output Voltage Swing	R <sub>L</sub> = 10kΩ R <sub>L</sub> = 2kΩ	± 12	± 13	—	± 12	± 13	—	± 12	± 13	—	V
			± 11	± 12.7	—	± 11	± 12.7	—	± 11	± 12.7	—	V
I <sub>S</sub>	Supply Current	OP-15 OP-16	—	2.7	4.0	—	2.7	4.0	—	2.8	5.0	mA
			—	4.6	7.0	—	4.6	7.0	—	4.8	8.0	mA
SR	Slew Rate	A <sub>VCL</sub> = +1 OP-15 OP-16	10	13	—	7.5	11	—	5	9	—	V/μs
			18	20	—	12	18	—	9	16	—	V/μs
GBW	Gain Bandwidth Product	(Note 3) OP-15 OP-16	4.0	6.0	—	3.5	5.7	—	3.0	5.4	—	MHz
			—	8.0	—	—	7.6	—	—	7.2	—	MHz
	Settling Time (Note 2)	to 0.01% to 0.10% OP-15	—	4.5	—	—	4.5	—	—	4.7	—	μs
			—	1.2	—	—	1.2	—	—	1.3	—	μs
		to 0.01% to 0.10% OP-16	—	3.8	—	—	3.8	—	—	4.0	—	μs
			—	0.9	—	—	0.9	—	—	1.0	—	μs
	Input Voltage Range		± 10.5	—	—	± 10.5	—	—	± 10.3	—	—	V
CMRR	Common-Mode Rejection Ratio	V <sub>CM</sub> = ± 10.5V V <sub>CM</sub> = ± 10.3V	86	100	—	86	100	—	82	96	—	dB
			—	—	—	—	—	—	—	—	—	dB
PSRR	Power Supply Rejection Ratio	V <sub>S</sub> = ± 10V to ± 18V V <sub>S</sub> = ± 10V to ± 15V	—	10	51	—	10	51	—	—	—	μV/V
			—	—	—	—	—	—	—	10	80	μV/V
e <sub>n</sub>	Input Noise Voltage Density	f <sub>0</sub> = 100Hz f <sub>0</sub> = 1000Hz	—	20	—	—	20	—	—	20	—	nV/√Hz
			—	15	—	—	15	—	—	15	—	nV/√Hz
i <sub>n</sub>	Input Noise Current Density	f <sub>0</sub> = 100Hz f <sub>0</sub> = 1000Hz	—	0.01	—	—	0.01	—	—	0.01	—	pA/√Hz
			—	0.01	—	—	0.01	—	—	0.01	—	pA/√Hz
C <sub>IN</sub>	Input Capacitance		—	3	—	—	3	—	—	3	—	pF

**ELECTRICAL CHARACTERISTICS**  $V_S = \pm 15V, -55^\circ C \leq T_A \leq 125^\circ C$  unless otherwise noted.

SYMBOL	PARAMETER	CONDITIONS		OP-15A OP-16A			OP-15B OP-16B			OP-15C OP-16C			UNITS
				MIN	TYP	MAX	MIN	TYP	MAX	MIN	TYP	MAX	
$V_{OS}$	Input Offset Voltage	$R_S = 50\Omega$	●	—	0.4	0.9	—	0.7	2.0	—	0.9	4.5	mV
$TCV_{OS}$	Average Input Offset Voltage Drift	$R_P = 100k\Omega$	●	—	2	5	—	3	10	—	4	15	$\mu V/^\circ C$
	Without External Trim		●	—	2	—	—	3	—	—	4	—	$\mu V/^\circ C$
$I_{OS}$	Input Offset Current	$T_J = 125^\circ C$ (Note 1) $T_A = 125^\circ C$ , Warmed-Up	●	—	0.6	4.0	—	0.8	6.0	—	1.0	9.0	nA
			●	—	0.8	7.0	—	1.2	11	—	1.5	17	nA
$I_B$	Input Bias Current	$T_J = 125^\circ C$ (Note 1) $T_A = 125^\circ C$ , Warmed-Up	●	—	$\pm 1.2$	$\pm 5.0$	—	$\pm 1.5$	$\pm 7.5$	—	$\pm 1.8$	$\pm 10$	nA
			●	—	$\pm 1.7$	$\pm 9.0$	—	$\pm 2.2$	$\pm 14$	—	$\pm 2.7$	$\pm 19$	nA
	Input Voltage Range		●	$\pm 10.4$	—	—	$\pm 10.4$	—	—	$\pm 10.25$	—	—	V
			●	85	97	—	85	97	—	80	93	—	—
$CMRR$	Common-Mode Rejection Ratio	$V_{CM} = \pm 10.4V$ $V_{CM} = \pm 10.25V$	●	—	—	—	—	—	—	—	—	—	dB
$PSRR$	Power Supply Rejection Ratio	$V_S = \pm 10V$ to $\pm 18V$ $V_S = \pm 10V$ to $\pm 15V$	●	—	15	57	—	15	57	—	—	—	$\mu V/V$
			●	—	—	—	—	—	—	23	100	—	$\mu V/V$
$A_{VOL}$	Large Signal Voltage Gain	$R_L \geq 2k\Omega$ $V_O = \pm 10V$	●	35	120	—	30	110	—	25	100	—	V/mV
$V_O$	Output Voltage Swing	$R_L \geq 10k\Omega$	●	$\pm 12$	$\pm 13$	—	$\pm 12$	$\pm 13$	—	$\pm 12$	$\pm 13$	—	V

**ELECTRICAL CHARACTERISTICS**  $V_S = \pm 15V, 0^\circ C \leq T_A \leq 70^\circ C$  unless otherwise noted.

SYMBOL	PARAMETER	CONDITIONS		OP-15E OP-16E			OP-15F OP-16F			OP-15G OP-16G			UNITS
				MIN	TYP	MAX	MIN	TYP	MAX	MIN	TYP	MAX	
$V_{OS}$	Input Offset Voltage	$R_S = 50\Omega$	●	—	0.3	0.75	—	0.55	1.5	—	0.7	3.8	mV
$TCV_{OS}$	Average Input Offset Voltage Drift	$R_P = 100k\Omega$	●	—	2	5	—	3	10	—	4	15	$\mu V/^\circ C$
	Without External Trim		●	—	2	—	—	3	—	—	4	—	$\mu V/^\circ C$
$I_{OS}$	Input Offset Current	$T_J = 70^\circ C$ (Note 1) $T_A = 70^\circ C$ , Warmed-Up	●	—	0.04	0.30	—	0.06	0.45	—	0.08	0.65	nA
			●	—	0.06	0.55	—	0.08	0.80	—	0.10	1.2	nA
$I_B$	Input Bias Current	$T_J = 70^\circ C$ (Note 1) $T_A = 70^\circ C$ , Warmed-Up	●	—	$\pm 0.10$	$\pm 0.40$	—	$\pm 0.12$	$\pm 0.60$	—	$\pm 0.14$	$\pm 0.80$	nA
			●	—	$\pm 0.13$	$\pm 0.75$	—	$\pm 0.16$	$\pm 1.1$	—	$\pm 0.19$	$\pm 1.5$	nA
	Input Voltage Range		●	$\pm 10.4$	—	—	$\pm 10.4$	—	—	$\pm 10.25$	—	—	V
			●	85	98	—	85	98	—	80	94	—	—
$CMRR$	Common-Mode Rejection Ratio	$V_{CM} = \pm 10.4V$ $V_{CM} = \pm 10.25V$	●	—	—	—	—	—	—	—	—	—	dB
$PSRR$	Power Supply Rejection Ratio	$V_S = \pm 10V$ to $\pm 18V$ $V_S = \pm 10V$ to $\pm 15V$	●	—	13	57	—	13	57	—	—	—	$\mu V/V$
			●	—	—	—	—	—	—	20	100	—	$\mu V/V$
$A_{VO}$	Large Signal Voltage Gain	$R_L \geq 2k\Omega$ $V_O = \pm 10V$	●	65	200	—	50	180	—	35	160	—	V/mV
$V_O$	Output Voltage Swing	$R_L \geq 10k\Omega$	●	$\pm 12$	$\pm 13$	—	$\pm 12$	$\pm 13$	—	$\pm 12$	$\pm 13$	—	V

The ● denotes the specifications which apply over full operating temperature range.

For MIL-STD components, please refer to LTC 883C data sheet for test listing and parameters.

**Note 1:** Input bias current is specified for two different conditions. The  $I_B$  specification is with the junction at ambient temperature; the warmed-up specification is with the device operating in a warmed-up condition at the ambient temperature specified.  $I_B$  and  $I_{OS}$  are measured at  $V_{CM} = 0$ .

**Note 2:** Settling time is defined here for a unity gain inverter connection using 2kΩ resistors. It is the time required for the error voltage (the voltage at the inverting input pin on the amplifier) to settle to within a specified percentage of its final value from the time a 10V step input is applied to the inverter.

**Note 3:** Sample tested.

**Note 4:** Unless otherwise specified, the absolute maximum negative input voltage is equal to the negative power supply voltage.



# APPLICATIONS

## Voltage Follower with Input Exceeding the Negative Common-Mode Range

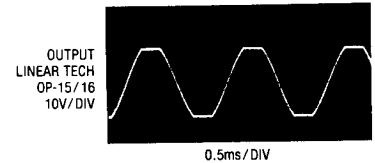
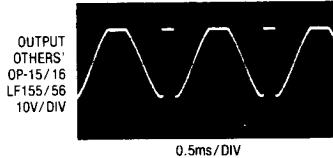
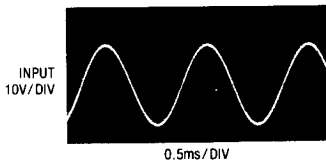
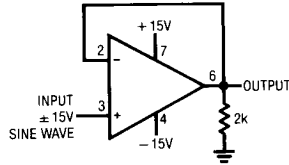

# PACKAGE DESCRIPTION

## H Package Metal Can

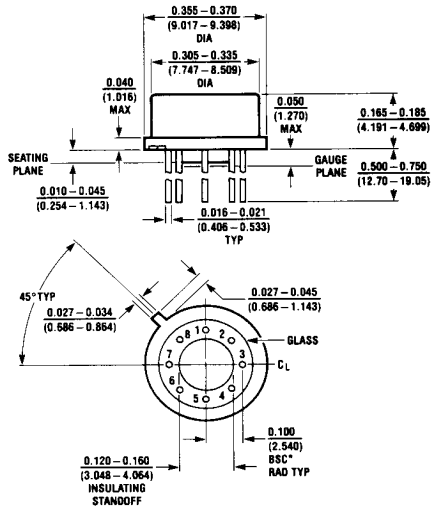

NOTE: DIMENSIONS IN INCHES

$T_{jmax}$	$\theta_{ja}$	$\theta_{jc}$
150°C	150°C/W	45°C/W

## N8 Package 8 Lead Plastic

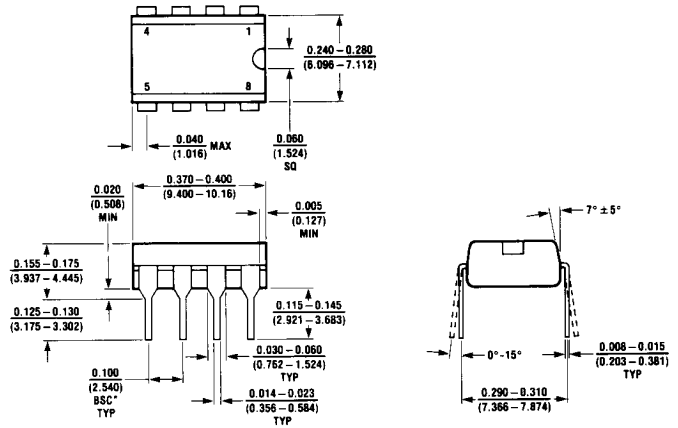

NOTE: DIMENSIONS IN INCHES UNLESS OTHERWISE NOTED  
\*LEADS WITHIN 0.007 OF TRUE POSITION (TP) AT GAUGE PLANE

$T_{jmax}$	$\theta_{ja}$
100°C	130°C/W