

<b>Consumer Electronics</b>	<b>MOS</b>
<b>Target Specification</b>	<b>Edition 11.94</b>

<b>SDA 5650</b>
<b>PDC plus</b>

<b>Document number: V66100-M692-X-1-7659</b>	<b>Date: 08.11.94</b>	<b>Page: ii</b>
--	-----------------------	-----------------

8235605 0079616 829

## Contents

<b>1</b>	<b>General Description</b> .....	<b>5</b>
<b>2</b>	<b>Features</b> .....	<b>5</b>
<b>3</b>	<b>Block Diagram</b> .....	<b>6</b>
<b>4</b>	<b>Pin Configurations</b> .....	<b>7</b>
4.1	Pin Description .....	8
<b>5</b>	<b>System Description</b> .....	<b>8</b>
5.1	Functions .....	8
5.2	I2C-Bus .....	10
5.2.1	General information .....	10
5.2.2	Chip Address .....	10
5.2.3	Write Mode .....	10
5.2.4	Read Mode .....	12
5.3	Order of Data Output on the I2C-Bus and Bit Allocation of PDC/VPS Operating Modes .....	13
5.4	Order of Data Output on the I2C-Bus and Bit Allocation for the Header Time Mode (MAB=0) .....	16
5.5	Description of DAVN and EHB outputs .....	24
<b>6</b>	<b>Electrical Characteristics</b> .....	<b>25</b>
<b>7</b>	<b>PDC/VPS-Receiver</b> .....	<b>28</b>
<b>8</b>	<b>Appendix</b> .....	<b>29</b>
8.1	Control register write (I2C Bus Write) .....	29
8.2	Data register read (I2C Bus Read) .....	30
8.3	DAVN and EHB timing .....	31
8.4	Position of Teletext and VPS Data Lines within the Vertical Blanking Interval .....	32
8.5	Definition of Voltage Levels for VPS Data Line .....	32
8.6	BDSP 8/30 Format 1 Bit Allocation .....	33
8.7	Structure of the Teletext Data Packet 8/30 Format 2 .....	34
8.8	BDSP 8/30 Format 2 Bit Allocation .....	35
8.9	Data Format of Programme Delivery Data in the Dedicated TV Line (VPS) .....	36

## 1 General Description

The PDC plus SDA 5650 decoder chip receives all VPS and 8/30 Format 1 and 2 data together with the teletxt header information for easy identification of broadcast transmitter. The SDA 5650 includes a storage capacity of 16 bytes which can be used in different ways depending on selected modes.

## 2 Features

- **Single chip receiver for PDC data for**  
Broadcast Data Service Packet (BDSP 8/30/2 according to CCIR teletext system B  
Data in dedicated line no. 16 of the vertical blanking interval (VPS)
- **Reception of BDSP packet 8/30/1**  
Unified Date and Time (UDT)  
Network identification code (NIC)  
Short program label (SPL)
- **Reception of teletext header row**  
Bytes no. 14 - 45 containing date, clock time and identification
- **On chip data slicer**
- **Low external component count**
- **I2C-Bus interface**  
communication with external micro-controller
- **PDC/VPS operation mode selectable via I2C Bus register**
- **Pin and software compatible to PDC/VPS decoder SDA 5649**
- **5V supply voltage**
- **Video input signal level: 0.7Vpp to 1.4 Vpp**
- **Technology: CMOS**
- **P-DIP-14 and P-DSO-20 package**

Siemens AG	Semiconductor Group	V66100-M692-X-1-7659	08.11.94	5
------------	---------------------	----------------------	----------	---

■ 8235605 0079618 6T1 ■

### 3 Block Diagram

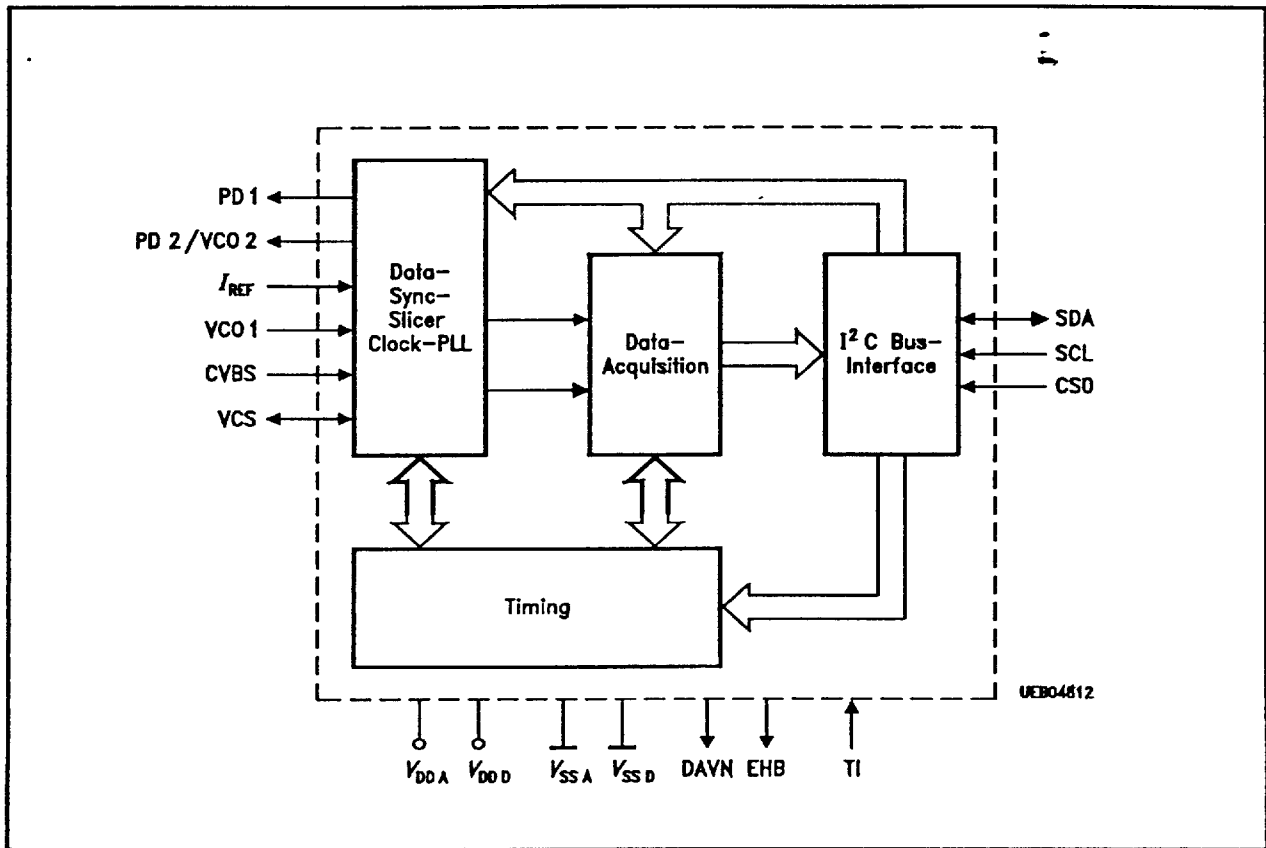

Siemens AG	Semiconductor Group	V66100-M692-X-1-7659	08.11.94	6
------------	---------------------	----------------------	----------	---

■ 8235605 0079619 538 ■

### 4 Pin Configurations

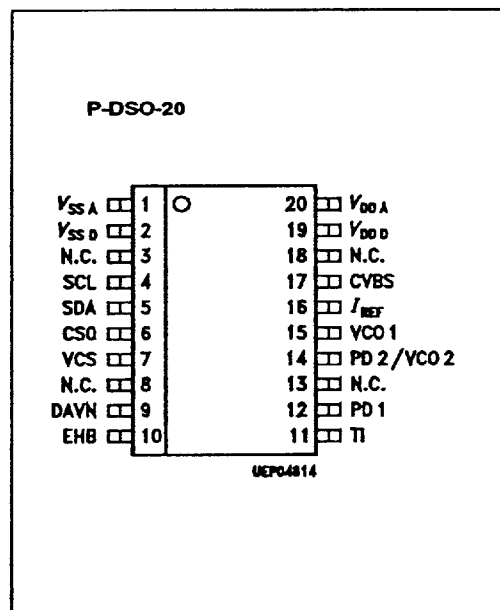
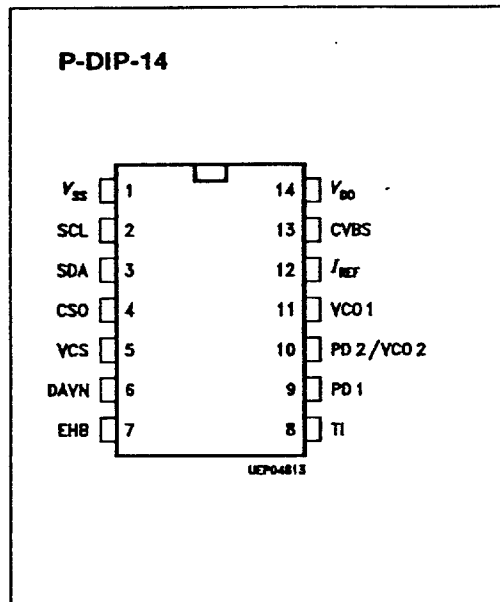

## 4.1 Pin Description

Pin No. P-DIP-14	Pin. No. P-DSO-20	Symbol	Function
1		VSS	Ground (0 V)
	1	VSSA	Analog ground (0 V)
	2	VSSD	Digital ground (0 V)
	3	N.C.	not connected
2	4	SCL	Serial clock input of I <sup>2</sup> C-Bus.
3	5	SDA	Serial data input of I <sup>2</sup> C-Bus.
4	6	CS0	Chip select input determining the I <sup>2</sup> C-Bus addresses: 20 <sub>H</sub> / 21 <sub>H</sub> , when pulled low 22 <sub>H</sub> / 23 <sub>H</sub> , when pulled high.
5	7	VCS	Video Composite Sync output from sync slicer used for PLL based clock generation.
	8	nc	not connected
6	9	DAVN	Data available output active low, when PDC/VPS data is received.
7	10	EHB	Output signaling the presence of the first field active high.
8	11	TI	Test input; activates test mode when pulled high. connect to ground for operating mode.
9	12	PD1	Phase detector/charge pump output of data PLL (DAPLL).
	13	N.C.	not connected
10	14	PD2/VCO2	Connector of the loop filter for the SYSPLL.
11	15	VCO1	Input to the voltage controlled oscillator #1 of the DAPLL.
12	16	I REF	Reference current input for the on-chip analog circuit.
13	17	CVBS	Composite video signal input.
	18	N.C.	not connected
14		VDD	Positive supply voltage (+ 5 V nom.).
	19	VDDD	Positive supply voltage for the digital circuits (+ 5 V nom.).
	20	VDDA	Positive supply voltage for the analog circuits (+ 5 V nom.).

## 5 System Description

### 5.1 Functions

Referring to the functional block diagram of the PDC / VPS decoder, the composite video signal with negative going sync pulses is coupled to the pin CVBS through a capacitor which is used for clamping the bottom of the sync pulses to an internally fixed level. The signal is passed on to the slicer, an analogue circuitry separating the sync and the data parts of the CVBS signal, thus yielding the digital composite sync signal VCS and a digital data signal for further processing by comparing those signals to internally generated slicing levels.

Siemens AG	Semiconductor Group	V66100-M692-X-1-7659	08.11.94	8
------------	---------------------	----------------------	----------	---

8235605 0079621 196

The output of the sync separator is forwarded, on one hand, to the output pin VCS, and on the other hand, to the clock generator and the Timing block. The VCS signal represents a key signal that is used for deriving a system clock signal by means of a PLL and all other timing signal.

The data slicer separates the data signal from the CVBS signal by comparing the video voltage to an internally generated slicing level which is found by averaging the data signal during TV line no. 16 in the VPS mode or by averaging the data signal during the clock run-in period of the teletext lines during the data entry window (DEW) in PDC mode.

The clock generator delivers the system clock needed for the basic timing as well as for the regeneration of the dataclock. It is based on two phase locked loops (PLL's) all parts of which are integrated on chip with the exception of the loop filter components. Each of the PLL's is composed of a voltage controlled relaxation oscillator (VCO), a phase/frequency detector (PFD), and a charge pump which converts the digital output signals of the PFD to an analogue current. That current is transformed to a control voltage for the VCO by the off-chip loop filter. The generated VCO frequencies are 10 MHz and 13.875 MHz for VPS mode and PDC mode, respectively.

All signals necessary for the control of sync and data slicing as well as for the data acquisition are generated by the Timing block.

The SDA 5650 can be operated in three different modes: Depending on the selected operating mode, either teletext lines carrying 8/30 packages, the dedicated TV line no. 16(VPS) or the teletext header bytes 38-45, 30-37, 22-29 and 14-21 are acquired.

In PDC mode, only teletext rows 8/30 containing Broadcast Data Service Package (BDSP) information are acquired. The relevant bytes of 8/30 format 1 (8/30/1) and 8/30 format 2 (8/30/2) are extracted. The 8/30/1-bytes are stored in the acquisition register in a transparent way without any bit manipulation, whereas the Hamming coded bytes of packet 8/30/2 are Hamming-checked and bytes with one bit error are corrected. The storage of error free or corrected 8/30/2-data bytes in the transfer register to the I<sup>2</sup>C bus is signalled by the DAVN output going low.

In VPS mode, the extracted data bits of TV line no. 16 are checked for biphasic errors. With no biphasic errors encountered, the acquired bytes are stored in the transfer register to the I<sup>2</sup>C bus. That transfer is signalled by a H/L transition of the DAVN output, as well.

In TTX header mode A bytes 38-45 and 30-37 are accessed in this order. This assures software compatibility to the SDA 5649. In mode B bytes 22-29 and 14-21 are accessed in this order.

In all three operating modes data are updated when a new data line has been received, provided that the chip is not accessed via the I<sup>2</sup>C bus at the same time.

A micro controller can read the stored bytes via the I<sup>2</sup>C bus interface at any time. However, one must be aware that the storage of new data from the acquisition interface is inhibited as long as the PDC decoder is being accessed via the I<sup>2</sup>C bus.

Siemens AG	Semiconductor Group	V66100-M692-X-1-7659	08.11.94	9
------------	---------------------	----------------------	----------	---

■ 8235605 0079622 022 ■

## 5.2 I<sup>2</sup>C-Bus

### 5.2.1 General information

The I<sup>2</sup>C-Bus interface implemented on the PDC decoder is a slave transmitter/receiver, i. e., both reading from and writing to the PDC / VPS decoder is possible. The clock line SCL is controlled only by the bus master usually being a micro controller, whereas the SDA line is controlled either by the master or by the slave. A data transfer can only be initiated by the bus master when the bus is free, i. e., both SDA and SCL lines are in a high state. As a general rule for the I<sup>2</sup>C-Bus, the SDA line changes state only when the SCL line is low. The only exception to that rule are the Start Condition and the Stop Condition. Further Details are given below. The following abbreviations are used:

START: Start Condition generated by master  
 AS: Acknowledge by slave  
 AM: Acknowledge by master  
 NAM: No Acknowledge by master  
 STOP: Stop condition generated by master

### 5.2.2 Chip Address

There are two pairs of chip addresses, which are selected by the CS0-input pin according to the following table:

CS0 Input	Write Mode	Read Mode
Low	20 (hex)	21 (hex)
High	22 (hex)	23 (hex)

### 5.2.3 Write Mode

For writing to the PDC decoder, the following format has to be used:

Start	Chipaddress and Write Mode	AS	Byte to set Control Register	AS	Stop
-------	----------------------------	----	------------------------------	----	------

#### Description of Data Transfer ( Write Mode )

- Step 1:** In order to start a data transfer the master generates a Start Condition on the bus by pulling the SDA line low while the SCL line is held high.
- Step 2:** The bus master puts the chip address on the SDA line during the next eight SCL pulses.
- Step 3:** The master releases the SDA line during the ninth clock pulse. Thus the slave can generate an acknowledge (AS) by pulling the SDA line to a low level.
- Step 4:** The controller transmits the data byte to set the Control register
- Step 5:** The slave acknowledges the reception of the byte.
- Step 6:** The master concludes the data communication by generating a Stop Condition.

Siemens AG	Semiconductor Group	V66100-M692-X-1-7659	08.11.94	10
------------	---------------------	----------------------	----------	----



The write mode is used to set the I<sup>2</sup>C-Bus control register which determines the operating mode:

Control register:

Bit Number:	7	6	5	4	3	2	1	0
	T4	T3	T2	T1	MAB	HDT	PDC/ -VPS	FOR1/ FOR2

Default: All bits are set to 0 on power-up.

Bits 3 through 7 are used for test purposes and must not be changed for normal operation by user software!

Bit 0: determines, which kind of data is accessed via the I<sup>2</sup>C-Bus when PDC mode is active:

Value	
0	1
BDSP 8/ 30/ 2 data accessible	BDSP 8/ 30/ 1 or header row data accessible (refer to description of Bit 2)

Bit 1: determines the operating mode:

Value	
0	1
VPS mode active	PDC mode active

Bit 2: determines whether BDSP 8/30/1-data or header row data is accessible:

Value	
0	1
BDSP 8/30/1 data accessible	Bytes of teletext header in mode A or B (see Bit 3)

Bit 3: determines mode of teletext header access:

Value	
0	1
Mode A: header bytes in order 38-45, 30-37	Mode B: header bytes in order 22-29, 14-21

Siemens AG	Semiconductor Group	V66100-M692-X-1-7659	08.11.94	11
------------	---------------------	----------------------	----------	----

8235605 0079624 9T5

### 5.2.4 Read Mode

For reading from the PDC decoder, the following format has to be used

Start	Chipaddress read Mode	AS	1st Byte	AM	.....	Last Byte	NAM	Stop
-------	-----------------------	----	----------	----	-------	-----------	-----	------

The contents of up to 13 registers (bytes) can be read starting with byte 1 bit 7 (refer to the table **Order of Data Output on the I<sup>2</sup>C-Bus and ...**) depending on the selected operating mode.

#### Description of Data Transfer ( Read Mode )

- Step 1:** To start a data transfer the master generates a Start Condition on the bus by pulling the SDA line low while the SCL line is held high. The byte address counter in the decoder is reset and points to the first byte to be output.
- Step 2:** The bus master puts the chip address on the SDA line during the next eight SCL pulses.
- Step 3:** The master releases the SDA line during the ninth clock pulse. Thus the slave can generate an acknowledge (AS) by pulling the SDA line to a low level. At this moment, the slave switches to transmitting mode.
- Step 4:** During the next eight clock pulses the slave puts the addressed data byte onto the SDA line.
- Step 5:** The reception of the byte is acknowledged by the master device which, in turn, pulls down the SDA line during the next SCL clock pulse. By acknowledging a byte, the master prompts the slave to increment its internal address counter and to provide the output of the next data byte.
- Step 6:** Steps no. 4 and no. 5 are repeated, until the desired amount of bytes have been read.
- Step 7:** The last byte is output by the slave since it will not be acknowledged by the master.
- Step 8:** To conclude the read operation, the master doesn't acknowledge the last byte to be received. A No Acknowledge by the master (NAM) causes the slave to switch from transmitting to receiving mode. Note that the master can prematurely cease any reading operation by not acknowledging a byte.
- Step 9:** The master gains control over the SDA line and concludes the data transfer by generating a Stop Condition on the bus, i. e., by producing a low/high transition on the SDA line while the SCL line is in a high state. With the SDA and the SCL lines being both in a high state, the I<sup>2</sup>C-Bus is free and ready for another data transfer to be started.

Siemens AG	Semiconductor Group	V66100-M692-X-1-7659	08.11.94	12
------------	---------------------	----------------------	----------	----

■ 8235605 0079625 831 ■

5.3 Order of Data Output on the I<sup>2</sup>C-Bus and Bit Allocation of PDC/VPS Operating Modes

I <sup>2</sup> C-Bus		PDC Packet 8/30				VPS Mode			
		Format 1		Format 2					
Byte 1	bit 7	byte 15	bit 0 <sup>2)</sup>	byte 16	bit 0 <sup>1)</sup>	byte 11	bit 0 <sup>2)</sup>		
	6		1		1		1		
	5		2		2		2		
	4		3		3		3		
	3		4		byte 17		bit 0	4	
	2		5					1	5
	1		6					2	6
	0		7		3		3	7	
Byte 2	bit 7	byte 16	bit 0	byte 18	bit 0	byte 12	bit 0		
	6		1		1		1		
	5		2		2		2		
	4		3		3		3		
	3		4		byte 19		bit 0	4	
	2		5					1	5
	1		6					2	6
	0		7		3		3	7	
Byte 3	bit 7	byte 17	bit 0	byte 20	bit 0	byte 13	bit 0		
	6		1		1		1		
	5		2		2		2		
	4		3		3		3		
	3		4		byte 21		bit 0	4	
	2		5					1	5
	1		6					2	6
	0		7		3		3	7	
Byte 4	bit 7	byte 18	bit 0	byte 22	bit 0	byte 14	bit 0		
	6		1		1		1		
	5		2		2		2		
	4		3		3		3		
	3		4		byte 23		bit 0	4	
	2		5					1	5
	1		6					2	6
	0		7		3		3	7	

1.) Message bit numbers according to EBU specification of PDC system.

2.) Transmission bit number

Order of Data Output on the I<sup>2</sup>C-Bus and Bit Allocation of PDC/VPS Operating Modes (cont'd)

I <sup>2</sup> C-Bus		PDC Packet 8/30				VPS Mode		
		Format 1		Format 2				
Byte 5	bit7	byte 19	bit0	byte 14	bit0	byte 5	bit0	
	6		1		1		1	
	5		2		2		2	
	4		3		3		3	
	3		4		byte 15		bit0	4
	2		5				1	5
	1		6				2	6
	0		7				3	7
Byte 6	bit7	byte 20	bit0	byte 24	bit0	byte 15	bit0	
	6		1		1		1	
	5		2		2		2	
	4		3		3		3	
	3		4		byte 25		bit0	4
	2		5				1	5
	1		6				2	6
	0		7				3	7
Byte 7	bit7	byte 21	bit0	byte 13	bit0	- set to "1" - set to "1" - set to "1" - set to "1" - set to "1" - set to "1" - set to "1" - set to "1"		
	6		1		1			
	5		2		2			
	4		3		3			
	3		4		- set to "1"			
	2		5					- set to "1"
	1		6					- set to "1"
	0		7					- set to "1"
Byte 8	bit7	byte 13	bit0					
	6		1					
	5		2					
	4		3					
	3		4					
	2		5					
	1		6					
	0		7					
Byte 9	bit7	byte 14	bit0					
	6		1					
	5		2					
	4		3					
	3		4					
	2		5					
	1		6					
	0		7					

Siemens AG	Semiconductor Group	V66100-M692-X-1-7659	08.11.94	14
------------	---------------------	----------------------	----------	----

8235605 0079627 604

I <sup>2</sup> C-Bus		PDC Packet 8/30		VPS Mode
		Format 1	Format 2	
Byte 10	bit7 6 5 4 3 2 1 0	byte 22	bit0 1 2 3 4 5 6 7	
Byte 11	bit7 6 5 4 3 2 1 0	byte 23	bit0 1 2 3 4 5 6 7	
Byte 12	bit7 6 5 4 3 2 1 0	byte 24	bit0 1 2 3 4 5 6 7	
Byte 13	bit7 6 5 4 3 2 1 0	byte 25	bit0 1 2 3 4 5 6 7	

Siemens AG	Semiconductor Group	V66100-M692-X-1-7659	08.11.94	15
------------	---------------------	----------------------	----------	----

8235605 0079628 540

5.4 Order of Data Output on the I<sup>2</sup>C-Bus and Bit Allocation for the Header Time Mode (MAB=0)

I <sup>2</sup> C-Bus		Header time Mode	
t ↓ Byte 1	bit 7	byte 38	bit 0 <sup>2)</sup>
	6		1
	5		2
	4		3
	3		4
	2		5
	1		6
	0		7
Byte 2	bit 7	byte 39	bit 0
	6		1
	5		2
	4		3
	3		4
	2		5
	1		6
	0		7
Byte 3	bit 7	byte 40	bit 0
	6		1
	5		2
	4		3
	3		4
	2		5
	1		6
	0		7
Byte 4	bit 7	byte 41	bit 0
	6		1
	5		2
	4		3
	3		4
	2		5
	1		6
	0		7

- 1.) Message bit numbers according to EBU specification of PDC system.
- 2.) Transmission bit number

**Order of Data Output on the I<sup>2</sup>C-Bus and Bit Allocation for the Header Time Mode**  
 (cont'd) (MAB=0)

I <sup>2</sup> C-Bus		Header Time Mode		
↓ t ↓	Byte 5	bit 7	byte 42	bit 0 <sup>2)</sup>
		6		1
		5		2
		4		3
		3		4
		2		5
		1		6
		0		7
	Byte 6	bit 7	byte 43	bit 0
		6		1
		5		2
		4		3
		3		4
		2		5
		1		6
		0		7
	Byte 7	bit 7	byte 44	bit 0
		6		1
		5		2
		4		3
		3		4
		2		5
		1		6
		0		7
	Byte 8	bit 7	byte 45	bit 0
		6		1
		5		2
		4		3
		3		4
		2		5
		1		6
		0		7

- 1.) Message bit numbers according to EBU specification of PDC system.
- 2.) Transmission bit number

**Order of Data Output on the I<sup>2</sup>C-Bus and Bit Allocation for the Header Time Mode**  
 (cont'd) (MAB=0)

I <sup>2</sup> C-Bus		Header Time Mode	
↓ Byte 9	bit 7	byte 30	bit 0 <sup>2)</sup>
	6		1
	5		2
	4		3
	3		4
	2		5
	1		6
	0		7
Byte 10	bit 7	byte 31	bit 0
	6		1
	5		2
	4		3
	3		4
	2		5
	1		6
	0		7
Byte 11	bit 7	byte 32	bit 0
	6		1
	5		2
	4		3
	3		4
	2		5
	1		6
	0		7
Byte 12	bit 7	byte 33	bit 0
	6		1
	5		2
	4		3
	3		4
	2		5
	1		6
	0		7

- 1.) Message bit numbers according to EBU specification of PDC system.
- 2.) Transmission bit number



Order of Data Output on the I<sup>2</sup>C-Bus and Bit Allocation for the Header Time Mode  
(cont'd) (MAB=0)

I <sup>2</sup> C-Bus		Header Time Mode		
↓ t	Byte 13	bit 7	byte 34	bit 0 <sup>2)</sup>
		6		1
		5		2
		4		3
		3		4
		2		5
		1		6
		0		7
	Byte 14	bit 7	byte 35	bit 0
		6		1
		5		2
		4		3
		3		4
		2		5
		1		6
		0		7
	Byte 15	bit 7	byte 36	bit 0
		6		1
		5		2
		4		3
		3		4
		2		5
		1		6
		0		7
	Byte 16	bit 7	byte 37	bit 0
		6		1
		5		2
		4		3
		3		4
		2		5
		1		6
		0		7

- 1.) Message bit numbers according to EBU specification of PDC system.
- 2.) Transmission bit number

**Order of Data Output on the I<sup>2</sup>C-Bus and Bit Allocation for the Header Time Mode**  
(cont'd) (MAB=1)

I <sup>2</sup> C-Bus		Header Time Mode		
↓ t	Byte 1	bit 7	byte 22	bit 0 <sup>2)</sup>
		6		1
		5		2
		4		3
		3		4
		2		5
		1		6
		0		7
Byte 2	bit 7	byte 23	bit 0	
	6		1	
	5		2	
	4		3	
	3		4	
	2		5	
	1		6	
	0		7	
Byte 3	bit 7	byte 24	bit 0	
	6		1	
	5		2	
	4		3	
	3		4	
	2		5	
	1		6	
	0		7	
Byte 4	bit 7	byte 25	bit 0	
	6		1	
	5		2	
	4		3	
	3		4	
	2		5	
	1		6	
	0		7	

- 1.) Message bit numbers according to EBU specification of PDC system.
- 2.) Transmission bit number

**Order of Data Output on the I<sup>2</sup>C-Bus and Bit Allocation for the Header Time Mode**  
(cont'd) (MAB=1)

I <sup>2</sup> C-Bus		Header Time Mode		
↓ t	Byte 5	bit 7	byte 26	bit 0 <sup>2)</sup>
		6		1
		5		2
		4		3
		3		4
		2		5
		1		6
		0		7
	Byte 6	bit 7	byte 27	bit 0
		6		1
		5		2
		4		3
		3		4
		2		5
		1		6
		0		7
	Byte 7	bit 7	byte 28	bit 0
		6		1
		5		2
		4		3
		3		4
		2		5
		1		6
		0		7
	Byte 8	bit 7	byte 29	bit 0
		6		1
		5		2
		4		3
		3		4
		2		5
		1		6
		0		7

- 1.) Message bit numbers according to EBU specification of PDC system.
- 2.) Transmission bit number

Order of Data Output on the I<sup>2</sup>C-Bus and Bit Allocation for the Header Time Mode  
(cont'd) (MAB=1)

I <sup>2</sup> C-Bus		Header Time Mode		
t ↓	Byte 9	bit 7	byte 14	bit 0 <sup>2)</sup>
		6		1
		5		2
		4		3
		3		4
		2		5
		1		6
		0		7
	Byte 10	bit 7	byte 15	bit 0
		6		1
		5		2
		4		3
		3		4
		2		5
		1		6
		0		7
	Byte 11	bit 7	byte 16	bit 0
		6		1
		5		2
		4		3
		3		4
		2		5
		1		6
		0		7
	Byte 12	bit 7	byte 17	bit 0
		6		1
		5		2
		4		3
		3		4
		2		5
		1		6
		0		7

- 1.) Message bit numbers according to EBU specification of PDC system.
- 2.) Transmission bit number

Order of Data Output on the I<sup>2</sup>C-Bus and Bit Allocation for the Header Time Mode  
(cont'd) (MAB=1)

I <sup>2</sup> C-Bus		Header Time Mode		
↓ t	Byte 13	bit 7	byte 18	bit0 <sup>2)</sup>
		6		1
		5		2
		4		3
		3		4
		2		5
		1		6
		0		7
	Byte 14	bit 7	byte 19	bit 0
		6		1
		5		2
		4		3
		3		4
		2		5
		1		6
		0		7
	Byte 15	bit 7	byte 20	bit 0
		6		1
		5		2
		4		3
		3		4
		2		5
		1		6
		0		7
	Byte 16	bit 7	byte 21	bit 0
		6		1
		5		2
		4		3
		3		4
		2		5
		1		6
		0		7

- 1.) Message bit numbers according to EBU specification of PDC system.
- 2.) Transmission bit number

## 5.5 Description of DAVN and EHB outputs

DAVN (Data Valid active low)

EHB (First Field active high)

signal output	VPS mode	PDC mode		
		8/30/2 mode	8/30/1 mode	Header Time
<b>DAVN</b>				
H/L-transition (set low)	in line 16 when valid VPS data is received	in the line carrying valid 8/30/2 data	in the line carrying valid 8/30/1 data	in the line carrying valid header row X/0 data
L/H-transition (set high)	at the start of line 16	at the beginning of the next field i.e., at the start of the next data entry window		
always set high	on power-up or during I2C bus accesses when the bus master doesn't acknowledge in order to generate the stop condition			
<b>EHB</b>				
L/H-transition	at the beginning of the first field			
H/L-transition	at the beginning of the second field			

In test mode (i.e. TI = high), both DAVN and EHB are controlled by the CS0 pin and reproduce the state of the CS0 input.

Siemens AG	Semiconductor Group	V66100-M692-X-1-7659	08.11.94	24
------------	---------------------	----------------------	----------	----

## 6 Electrical Characteristics

### Absolute Maximum Ratings

$T_A = 25\text{ }^\circ\text{C}$

Parameter	Symbol	Limit Values			Unit	Test Condition
		min.	typ.	max.		
Ambient temperature	$T_A$	0		70	$^\circ\text{C}$	in operation
Storage temperature	$T_{stg}$	-40		125	$^\circ\text{C}$	by storage
Total power dissipation	$P_{tot}$			300	mW	
Power dissipation per output	$P_{DQ}$			10	mW	
Input voltage	$V_{IM}$	-0.3		6	V	
Supply voltage	$V_{DD}$	-0.3		6	V	
Thermal resistance	$R_{th\text{ SU}}$			80	K/W	

### Operating Range

Supply voltage	$V_{DD}$	4.5	5	5.5	V	
Supply current	$I_{DD}$		5	15	mA	
Ambient temperature range	$T_A$	0		70	$^\circ\text{C}$	

### Characteristics

$T_A = 25\text{ }^\circ\text{C}$

Parameter	Symbol	Limit Values			Unit	Test Condition
		min.	typ.	max.		

#### Input Signals SDA, SCL, CS0

H-input voltage	$V_{IH}$	$0.7 \times V_{DD}$		$V_{DD}$	V	
L-input voltage	$V_{IL}$	0		$0.3 \times V_{DD}$	V	
Input capacitance	$C_I$			10	pF	
Input current	$I_{IM}$			10	$\mu\text{A}$	

#### Input Signal TI

H-input voltage	$V_{IH}$	$0.9 \times V_{DD}$		$V_{DD}$	V	
L-input voltage	$V_{IL}$	0		$0.1 \times V_{DD}$	V	
Input capacitance	$C_I$			10	pF	
Input current	$I_{IM}$			10	$\mu\text{A}$	

MC Input Filter Adjustment

$R_1$	$R_2$	$R_3$	$R_4$	$R_5$	$R_6$	$R_7$	$R_8$	$R_9$	$R_{10}$	$R_{11}$	$R_{12}$	$R_{13}$	$R_{14}$	$R_{15}$	$R_{16}$	$R_{17}$	$R_{18}$	$R_{19}$	$R_{20}$	$R_{21}$	$R_{22}$	$R_{23}$	$R_{24}$	$R_{25}$	$R_{26}$	$R_{27}$	$R_{28}$	$R_{29}$	$R_{30}$	$R_{31}$	$R_{32}$	$R_{33}$	$R_{34}$	$R_{35}$	$R_{36}$	$R_{37}$	$R_{38}$	$R_{39}$	$R_{40}$	$R_{41}$	$R_{42}$	$R_{43}$	$R_{44}$	$R_{45}$	$R_{46}$	$R_{47}$	$R_{48}$	$R_{49}$	$R_{50}$	$R_{51}$	$R_{52}$	$R_{53}$	$R_{54}$	$R_{55}$	$R_{56}$	$R_{57}$	$R_{58}$	$R_{59}$	$R_{60}$	$R_{61}$	$R_{62}$	$R_{63}$	$R_{64}$	$R_{65}$	$R_{66}$	$R_{67}$	$R_{68}$	$R_{69}$	$R_{70}$	$R_{71}$	$R_{72}$	$R_{73}$	$R_{74}$	$R_{75}$	$R_{76}$	$R_{77}$	$R_{78}$	$R_{79}$	$R_{80}$	$R_{81}$	$R_{82}$	$R_{83}$	$R_{84}$	$R_{85}$	$R_{86}$	$R_{87}$	$R_{88}$	$R_{89}$	$R_{90}$	$R_{91}$	$R_{92}$	$R_{93}$	$R_{94}$	$R_{95}$	$R_{96}$	$R_{97}$	$R_{98}$	$R_{99}$	$R_{100}$
-------	-------	-------	-------	-------	-------	-------	-------	-------	----------	----------	----------	----------	----------	----------	----------	----------	----------	----------	----------	----------	----------	----------	----------	----------	----------	----------	----------	----------	----------	----------	----------	----------	----------	----------	----------	----------	----------	----------	----------	----------	----------	----------	----------	----------	----------	----------	----------	----------	----------	----------	----------	----------	----------	----------	----------	----------	----------	----------	----------	----------	----------	----------	----------	----------	----------	----------	----------	----------	----------	----------	----------	----------	----------	----------	----------	----------	----------	----------	----------	----------	----------	----------	----------	----------	----------	----------	----------	----------	----------	----------	----------	----------	----------	----------	----------	----------	----------	----------	-----------

Siemens AG	Semiconductor Group	V66100-M692-X-1-7659	08.11.94	25
------------	---------------------	----------------------	----------	----

8235605 0079638 49T

PAGE(S) INTENTIONALLY BLANK

■ 8235605 0079639 326 ■

26



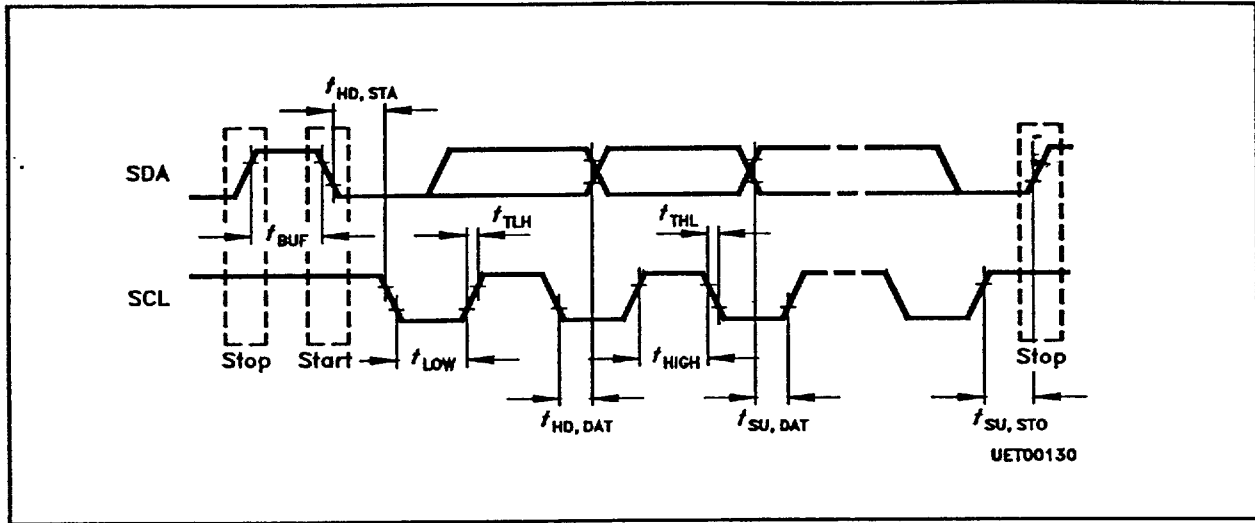

UET00130

I<sup>2</sup>C BUS Timing

Parameter	Symbol	Limit Values		Unit
		min.	max.	
Clock frequency	f SCL	0	100	kHz
Inactive time prior to new transmission start-up	t BUF	4.7		μs
Hold time during start condition	t HD;STA	4.0		μs
Low-period of clock	t LOW	4.7		μs
High-period of clock	t HIGH	4.0		μs
Set-up time for data	t SU;DAT	250		ns
Rise time for SDA and SCL signal	t TLH		1	μs
Fall time for SDA and SCL signal	t THL		300	ns
Set-up time for SCL clock during stop condition	t SU;STO	4.7		μs

All values referred to VIH and VIL levels.

7 PDC/VPS-Receiver

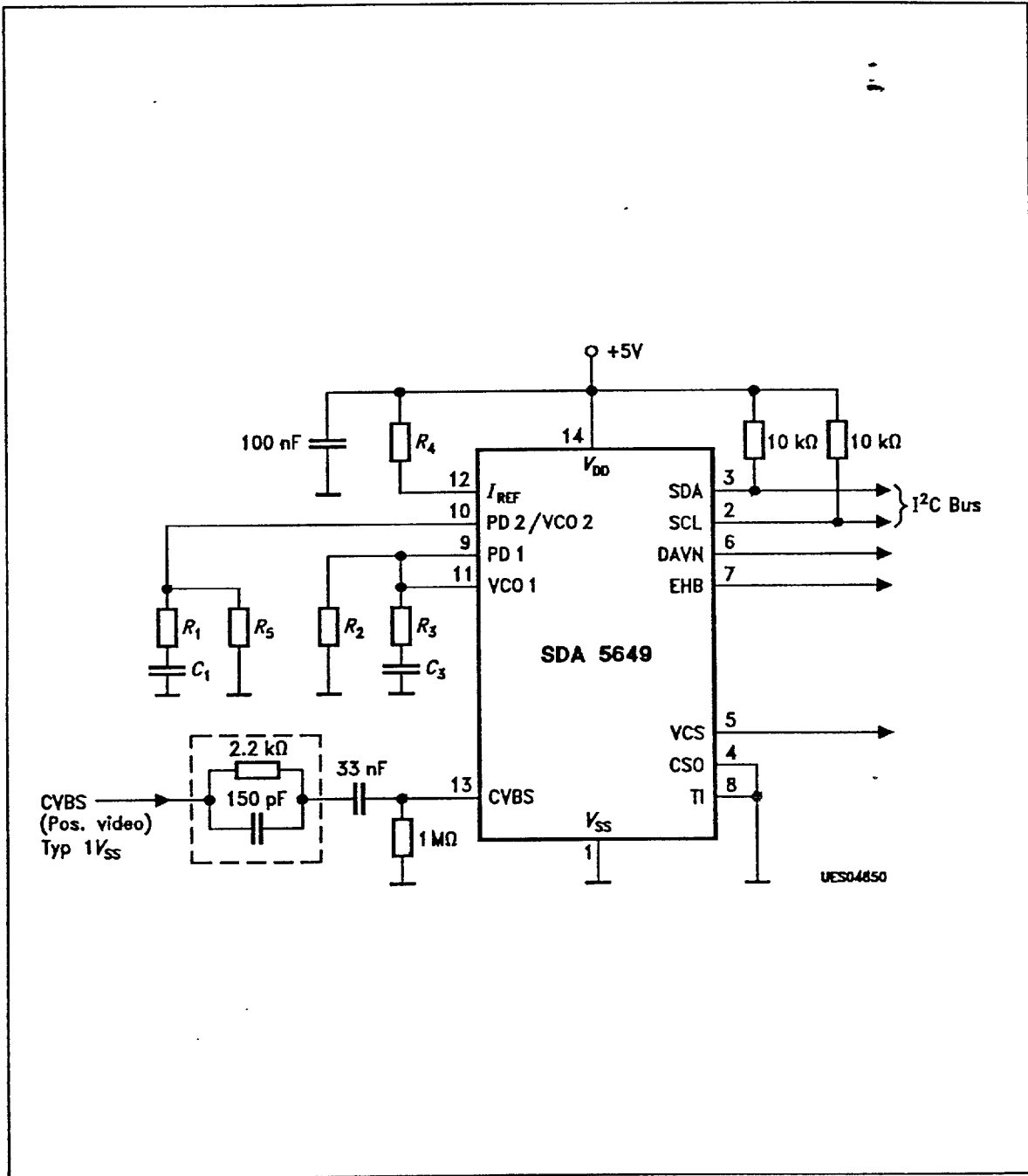

Siemens AG	Semiconductor Group	V66100-M692-X-1-7659	08.11.94	28
------------	---------------------	----------------------	----------	----

8235605 0079641 T84

## 8 Appendix

### 8.1 Control register write (I<sup>2</sup>C Bus Write)

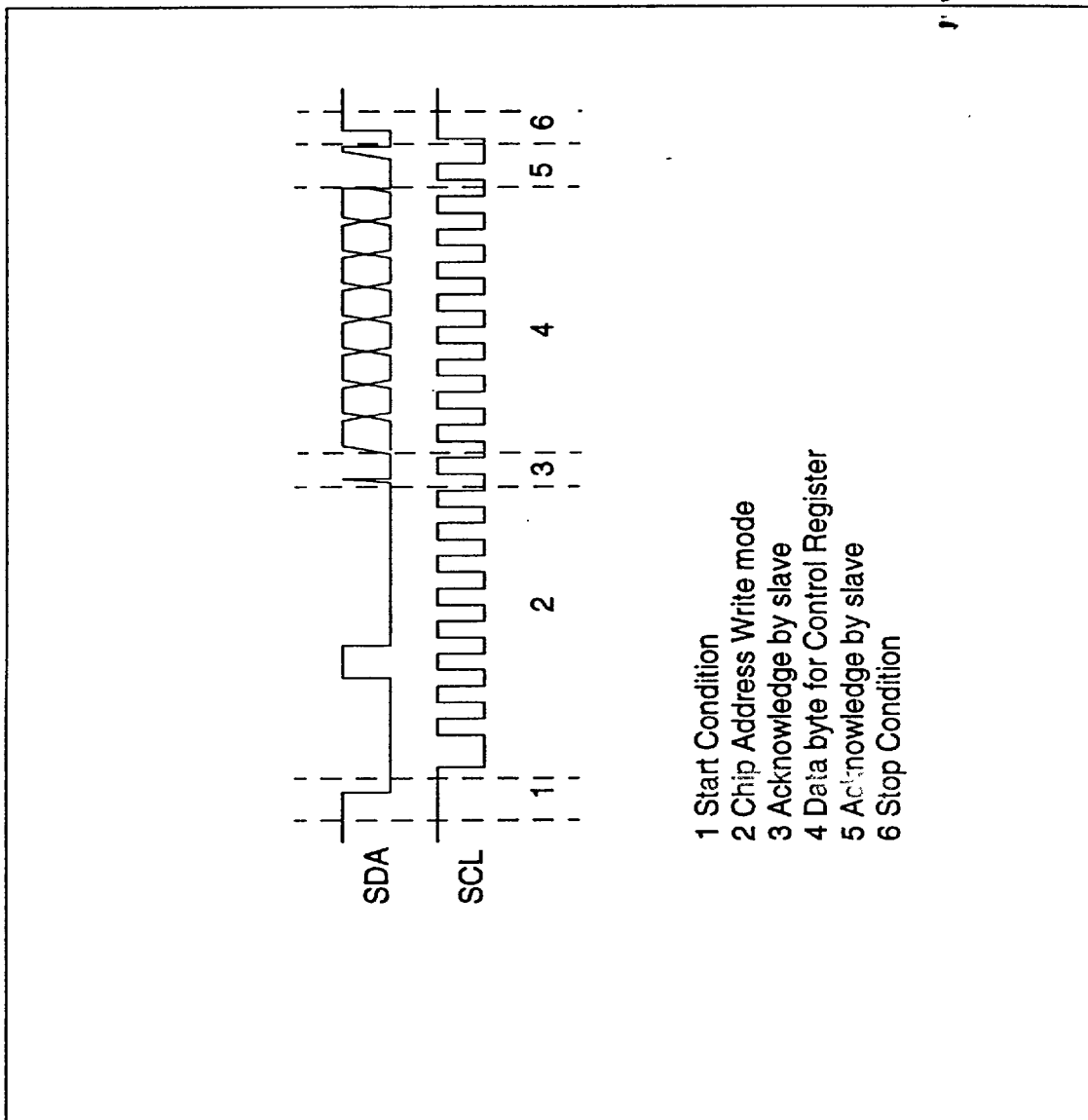

- 1 Start Condition
- 2 Chip Address Write mode
- 3 Acknowledge by slave
- 4 Data byte for Control Register
- 5 Acknowledge by slave
- 6 Stop Condition

8.2 Data register read (I<sup>2</sup>C Bus Read)

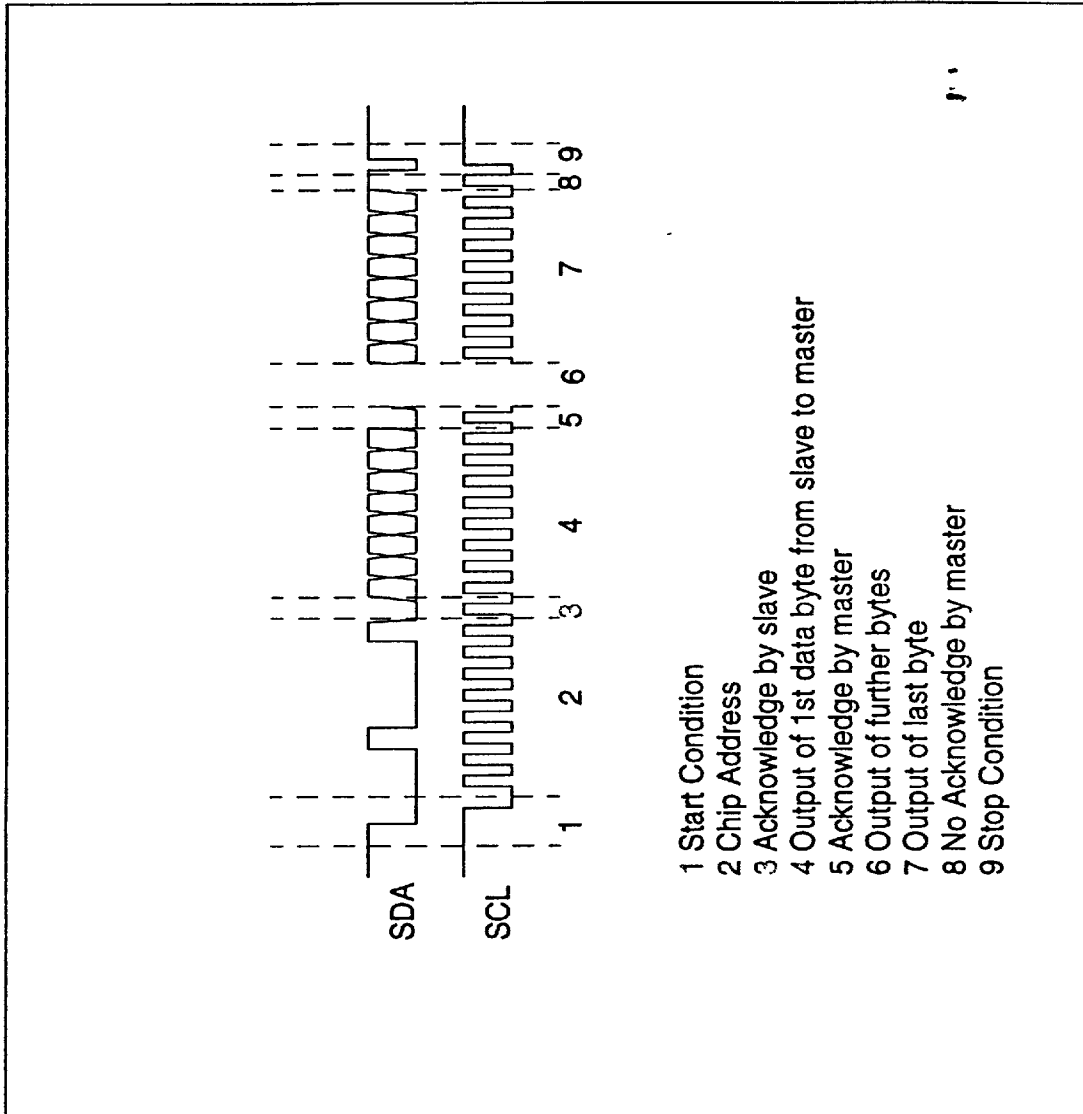

8.3 DAVN and EHB timing

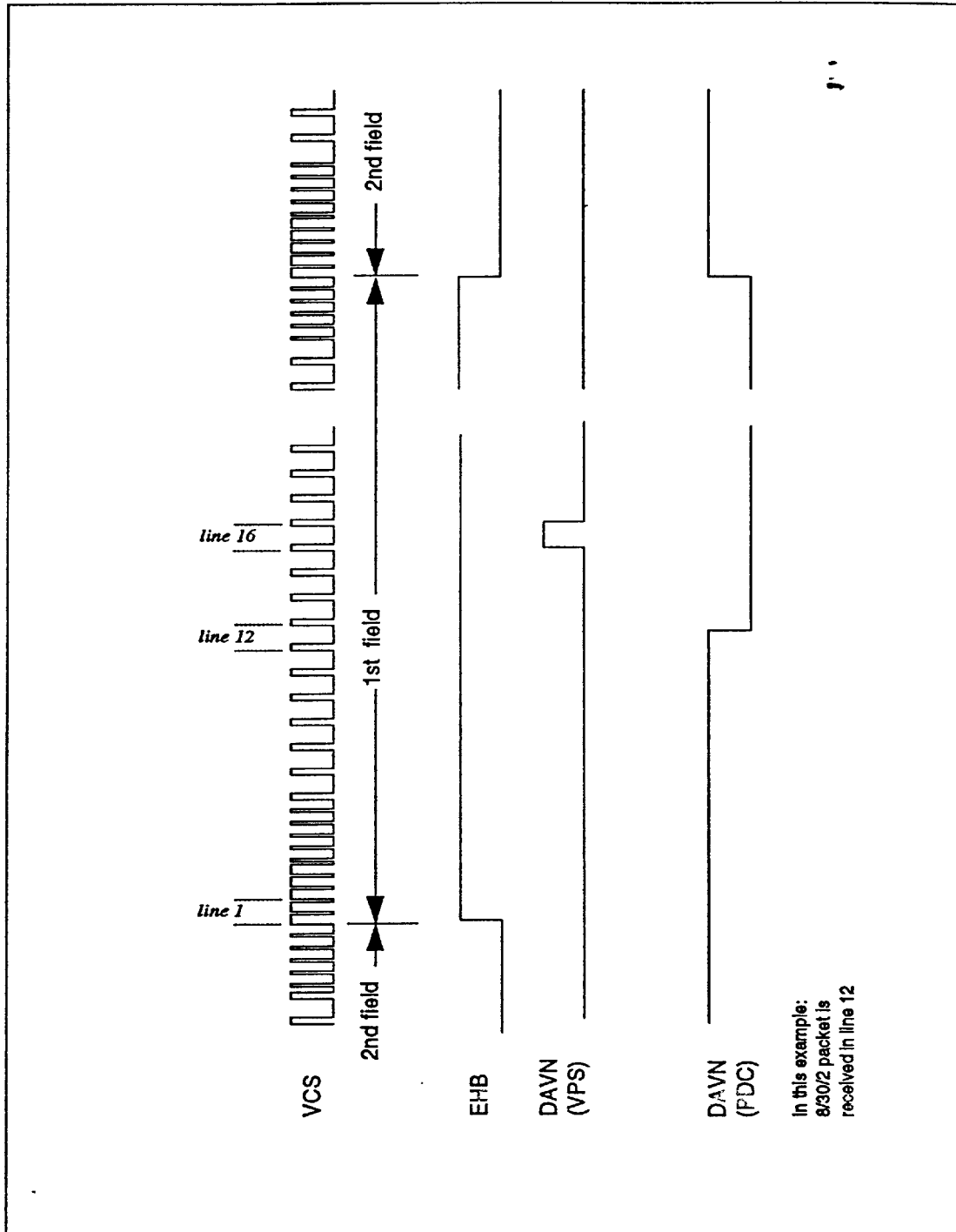

8.4 Position of Teletext and VPS Data Lines within the Vertical Blanking Interval

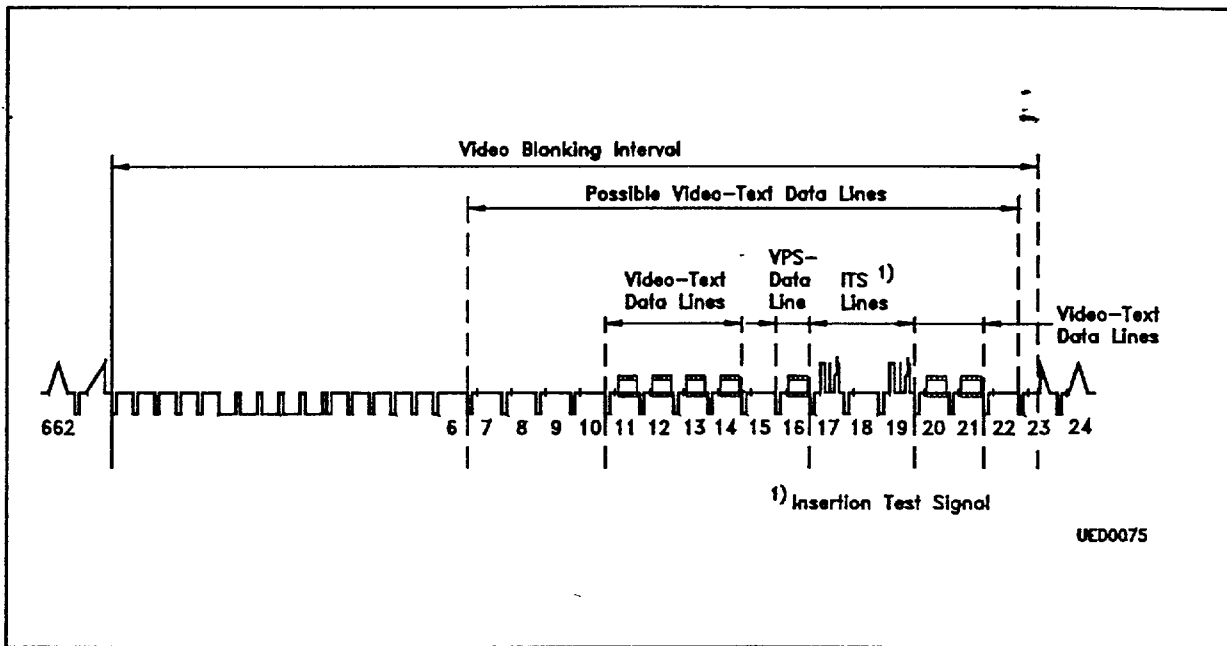

I  
(shown for first field)

8.5 Definition of Voltage Levels for VPS Data Line

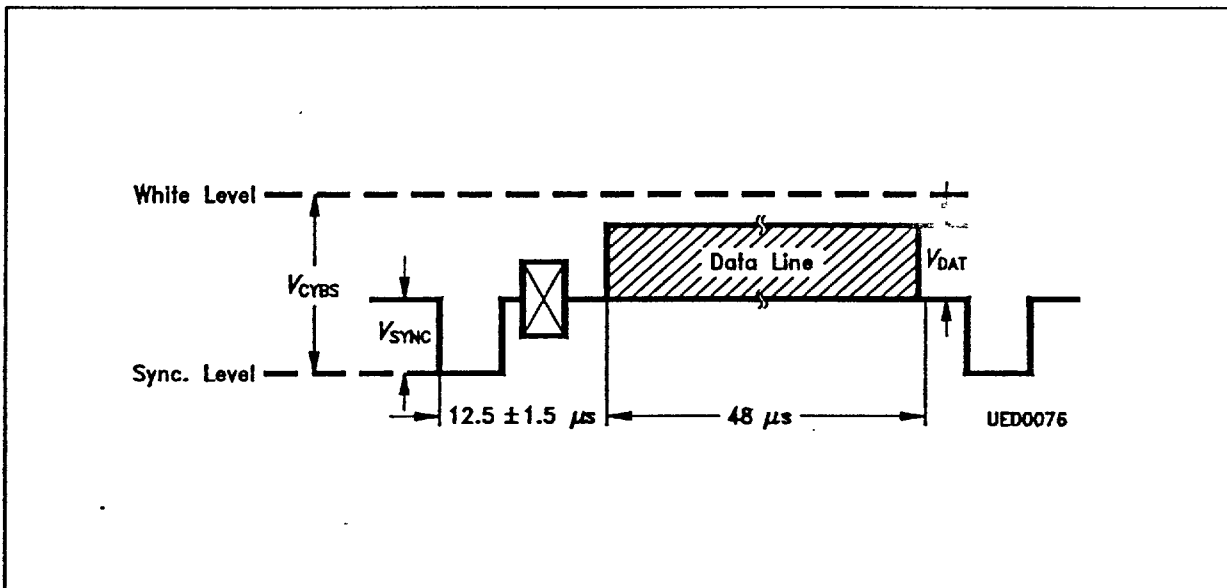

Siemens AG	Semiconductor Group	V66100-M692-X-1-7659	08.11.94	32
------------	---------------------	----------------------	----------	----

8235605 0079645 62T

8.6 BDSP 8/30 Format 1 Bit Allocation

Byte No.	Bit No.								Contents
	0	1	2	3	4	5	6	7	
13									Network Identification 1. Byte
14									Network Identification 2. Byte
15	Weight			Weight			Sign		Time Offset Code
	$2^{-2}$	$2^{-1}$	$2^0$	$2^1$	$2^2$	$2^3$	0 1		
16	MJD Digit Weight $10^4$			1 1 1 1				Modified Julian Date (MJD) 1. Byte	
17	MJD Digit Weight $10^2$			MJD Digit Weight $10^3$				Modified Julian Date 2. Byte	
18	MJD Digit Weight $10^0$			MJD Digit Weight $10^1$				Modified Julian Date (MJD) 3. Byte	
19	UTC Hours Units			UTC Hours Tens				Universal Time Coordinated (UTC) 1. Byte	
20	UTC Minutes Units			UTC Minutes Tens				Universal Time Coordinated 2. Byte	
21	UTC Seconds Units			UTC Seconds Tens				Universal Time Coordinated 3. Byte	
22									Short Programme Label 1. Byte
23									Short Programme Label 2. Byte
24									Short Programme Label 3. Byte
25									Short Programme Label 4. Byte

This corresponds to the coding adopted in CCIR teletext system B BDSP 8/30 format 1.

NB: The received bytes are output on the I<sup>2</sup>C-bus in a transparent way, i.e., on a bit-first-in-first-out basis. No bit manipulation is performed on the chip in this operating mode.

Concerning bytes no. 16 through 21: When evaluating the numbers, note that each 4-bit-digit has been incremented by one prior to transmission, and the least significant bits are transmitted first.

8.7.3.3 Structure of the Teletext Data Packet 8/30 Format 2

