

Intronics

C 300/400 SERIES MONOLITHIC WIDEBAND CRT DISTORTION CORRECTION DEVICE

FEATURES

- 16 pin ceramic dip (C300 Series)
- Minimum of external components required
- Easily adjusts for yoke errors
- Accuracy better than 0.5% Max (C312)
- Bandwidth compatible with 10MHz systems
- Both geometry and focus available
- MIL 883C available
- Low cost

APPLICATIONS (for Vector Displays Only)

- Military Displays
 - HUDS
 - ATC
 - HDSS
 - PPI
- Simulators
 - Beam Penetration
 - Shadow mask
- Phototypesetting equipment
- Computer Output Microfilm displays
- Computer driven graphic displays
- Medical monitors
- CAD displays
- TV Cameras and projection systems

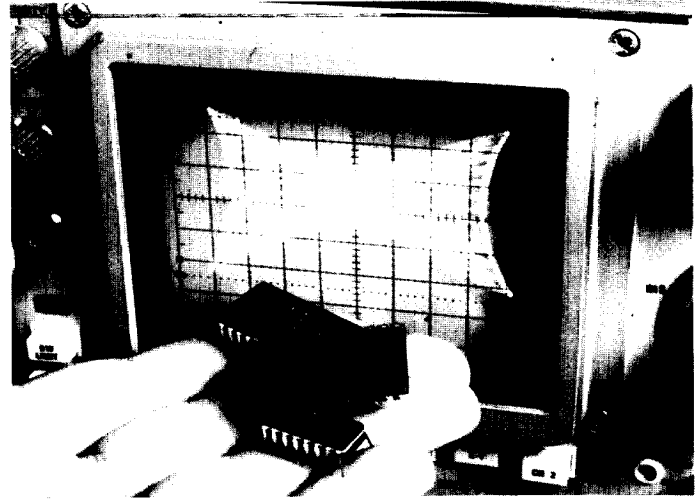

TRANSFER FUNCTION: GEOMETRY CORRECTION FOCUS CORRECTION

$$V_X = -x(x^2 + y^2)$$

$$V_Y = -y(x^2 + y^2)$$

$$V_F = -(x^2 + y^2)$$

PINOUT

H = HORIZONTAL
V = VERTICAL

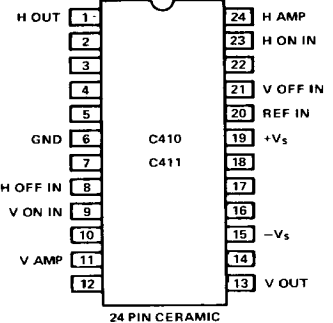
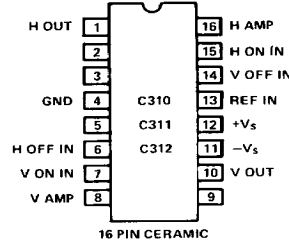

DESCRIPTION

The Intronics C300/400 Series are monolithic devices that accurately correct for geometric or focus distortion in CRT displays. The C300 (16 pin DIP) series provides wideband, accurate full face geometry or focus correction with few external components. These units connect between the horizontal and vertical inputs and their deflection amplifiers. Simple external adjustments provide for correction magnitude, horizontal/vertical keystone and curvature symmetry. The C400 series (24 pin DIP) is a full Mil temp range, -55°C to +125°C device.

The principle of operation is based on circuitry which smoothly synthesizes a correction function that closely approximates the exact mathematical correction function.

TOP VIEW

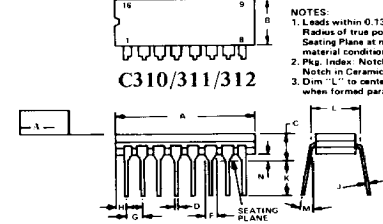

MECHANICAL DIMENSIONS

DIM	MILLIMETERS		INCHES	
	MIN	MAX	MIN	MAX
A	19.05	19.81	0.750	0.780
B	6.22	6.98	0.245	0.275
C	4.05	5.08	0.160	0.200
D	0.38	0.51	0.015	0.020
F	1.40	1.65	0.055	0.065
G	2.54 BSC		0.100 BSC	
H	0.51	1.14	0.020	0.045
J	0.20	0.30	0.003	0.012
K	3.18	4.06	0.125	0.160
L	7.37	7.87	0.029	0.310
M	-		15°	15°
N	0.51	1.02	0.020	0.040

TOP VIEW

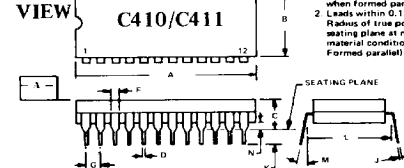

DIM	MILLIMETERS		INCHES	
	MIN	MAX	MIN	MAX
A	31.24	32.26	1.230	1.270
B	12.70	13.72	0.500	0.540
C	4.06	5.03	0.150	0.200
D	0.41	0.51	0.016	0.020
F	1.27	1.52	0.050	0.060
G	2.54 BSC		0.100 BSC	
J	0.20	0.30	0.008	0.012
K	2.92	3.43	0.115	0.135
L	15.31 BSC	0.606 BSC		
M	5°	15°	5°	15°
N	0.51	0.76	0.020	0.030

57 Chapel Street, Newton, MA 02158 • (617) 964-4000 • TWX 710-335-6835 • TELEX 200095 INTL UR • FAX (617) 527-3310

INTRONICS
C300/400 SERIES TECHNICAL SPECIFICATIONS

ABSOLUTE MAXIMUM RATINGS

SUPPLY VOLTAGE
(Between $V_S +$ and $V_S -$) 20V

OPERATING TEMPERATURE

C310 SERIES $-25^{\circ}\text{C} \leq T_A \leq +85^{\circ}\text{C}$
C410 SERIES $-55^{\circ}\text{C} \leq T_A \leq +125^{\circ}\text{C}$

INTERNAL POWER DISSIPATION
700mW max
(includes external load resistors)

STORAGE TEMPERATURE

C310 SERIES $-25^{\circ}\text{C} \leq T_A \leq +85^{\circ}\text{C}$
C410 SERIES $-55^{\circ}\text{C} \leq T_A \leq +150^{\circ}\text{C}$

PERFORMANCE SUMMARY (TYPICAL AT $+25^{\circ}\text{C}$, RATED SUPPLIES, TEST CIRCUIT FIG. 3($\pm 6\text{VDC}$), UNLESS OTHERWISE NOTED)

SPECIFICATIONS-GEOMETRY	C310 SERIES C310/C311/C312	C410 SERIES C410/C411
Horizontal/Vertical		
Correction Function		
Output (for geometry configuration)		
Horizontal Output	1V F.S.	1V F.S.
Vertical Output	1V F.S.	1V F.S.
Bandwidth		
Correction only	2MHZ Min. See note (1)	2MHZ Min. See note (1)
Resulting corrected signal	6MHZ Min.	6MHZ Min.
Slew Rate		
Correction only	15V/ μs	15V/ μs
Resulting corrected signal	120V/ μs	120V/ μs
Settling Time To 1%		
Correction only	300ns	300ns
Resulting corrected signal	2 μs	2 μs
Delay Time	50ns	50ns
Offset Temperature	50 $\mu\text{V}/^{\circ}\text{C}$	50 $\mu\text{V}/^{\circ}\text{C}$
Stability		
Output Resistance	40 Ω Max	40 Ω Max
Accuracy		

FIG. 1

Resulting Accuracy
of Corrected Function
by total deflection angle
(test circuit Fig. 3)

	Uncorrected	C310	C311	C312	C410	C411	
20°	1.5	.30	.15	.08	.15	.08	% Max
30°	3.5	.68	.34	.17	.34	.17	% Max
40°	6.4	1.24	.62	.31	.62	.31	% Max
50°	10.3	2.00	1.00	.50	1.00	.50	% Max
60°	15.5	3.00	1.50	.75	1.50	.75	% Max
70°	22.0	4.28	2.14	1.07	2.14	1.07	% Max
80°	31.0	6.00	3.00	1.50	3.00	1.50	% Max

SPECIFICATIONS-FOCUS (FIG.5)

Bandwidth	2MHZ Min.	2MHZ Min.
Slew Rate	15V/ μs	15V/ μs
Horizontal Output	-1.00V F.S.	-1.00V F.S.
Vertical Output	-1.00V F.S.	-1.00V F.S.
Offset Temperature	50 $\mu\text{V}/^{\circ}\text{C}$	50 $\mu\text{V}/^{\circ}\text{C}$
Stability		
Output resistance	40 Ω Max	40 Ω Max
Accuracy		
Horizontal	2% F.S.	2% F.S.
Vertical	2% F.S.	2% F.S.

SPECIFICATIONS-GENERAL

Transfer Function		
Geometry		
Horizontal	$-x(x^2+y^2)$	$-x(x^2+y^2)$
Vertical	$-y(x^2+y^2)$	$-y(x^2+y^2)$
Focus		
Horizontal	$-x^2$	$-x^2$
Vertical	$-y^2$	$-y^2$
Temperature Range for full rated performance		
Rated Specifications	0 $^{\circ}\text{C}$ to +70 $^{\circ}\text{C}$	-40 $^{\circ}\text{C}$ to +125 $^{\circ}\text{C}$
Storage	-25 $^{\circ}\text{C}$ to +85 $^{\circ}\text{C}$	-55 $^{\circ}\text{C}$ to +150 $^{\circ}\text{C}$
Power Supply ($\pm V_S$)	$\pm 6\text{V}$	$\pm 6\text{V}$
Quiescent Current	32mA typical	32mA typical

NOTE 1. For wide bandwidth use Intronics A504

TYPICAL APPLICATION CIRCUIT (C310); GEOMETRY CORRECTION
FIG. 2

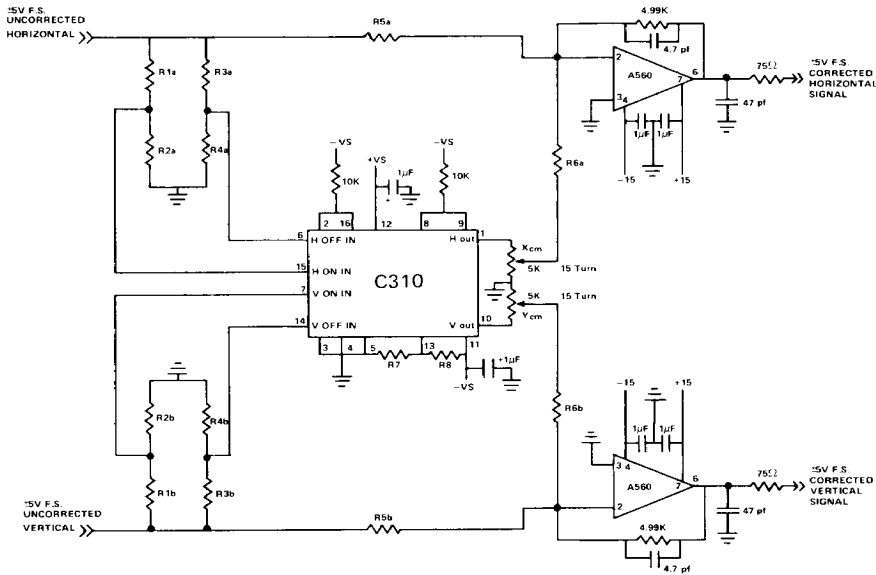

C310 ADJUSTMENT PROCEDURE

1. Adjust Horizontal Correction Magnitude potentiometer for optimonly straight vertical lines.
2. Adjust Vertical Correction Magnitude potentiometer for optimonly straight horizontal lines.

NOTE: 1. The circuit shown is a typical configuration to correct for 'pincushion' distortion.
 2. Only 2 potentiometers (X_{cm} and Y_{cm}) are required for 2% FS accuracy (50° full angle deflection).

TYPICAL APPLICATION CIRCUIT C311, 312, 410, 411; GEOMETRY CORRECTION

FIG. 3

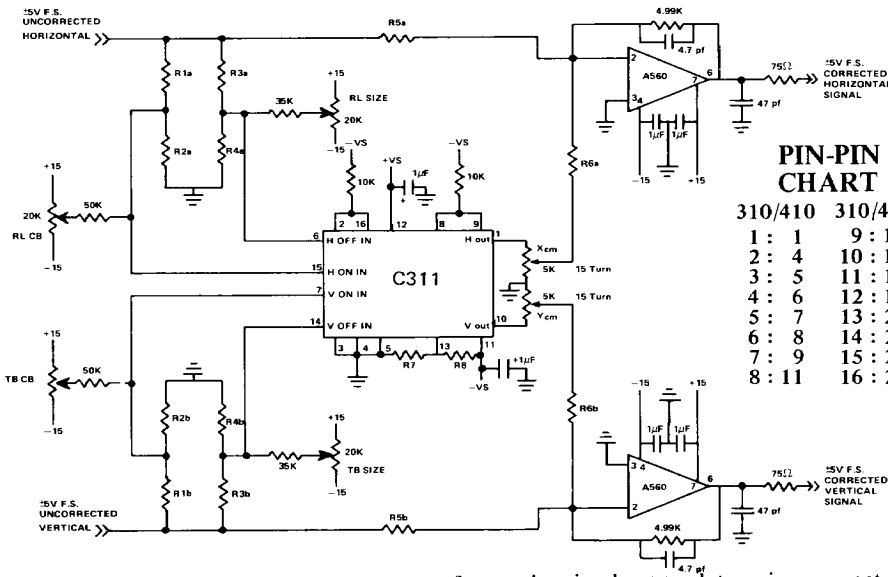

C311, 312, 410, 411

1. Adjust Horizontal Correction Magnitude potentiometer for optimonly straight vertical lines.
2. Adjust Vertical Correction Magnitude potentiometer for optimonly straight horizontal lines.
3. Adjust right/left curvature balance potentiometer for optimonly straight vertical "On-Axis" line.
4. Adjust top/bottom curvature balance potentiometer for optimonly straight horizontal "On-Axis" line.
5. Adjust right/left size potentiometer until right side is same size as left side.
6. Adjust top/bottom size potentiometer until top is same size as bottom.
7. Repeat steps 1-6 until desired accuracy is obtained.

PIN-PIN CHART

310/410	310/410
1 : 1	9 : 12
2 : 4	10 : 13
3 : 5	11 : 15
4 : 6	12 : 19
5 : 7	13 : 20
6 : 8	14 : 21
7 : 9	15 : 23
8 : 11	16 : 24

Note: C311 is shown. For C410-411 refer to pin-pin chart to determine correct pin designations.

FIG. 4

COMPONENT VALUES (K OHM) FOR $\pm 5V$ FULL SCALE INPUT AND OUTPUT
NOTE: VALUES SHOWN ARE CALCULATED-TOLERANCE RECOMMENDED $\pm 5\%$

TOTAL DEFLECTION	R1	R2	R3	R4	R5	R6	R7	R8
20°	2.1K	.4K	2K	.475K	4.92K	20K	.13K	1.07K
30°	2.1K	.4K	2.05K	.45K	4.83K	20K	.20K	1.0K
40°	2.1K	.4K	2.1K	.425K	4.69K	10K	.26K	.94K
50°	2.1K	.4K	2.1K	.425K	4.53K	5K	.32K	.88K
60°	2.1K	.4K	2.1K	.425K	4.33K	4K	.36K	.84K
70°	2.1K	.4K	2.1K	.425K	4.09K	3K	.39K	.81K
80°	2.1K	.4K	2.1K	.425K	3.83K	2K	.42K	.78K
90°	2.1K	.4K	2.1K	.425K	3.53K	1.5K	.46K	.77K

**RESULTING INPUT LEVELS VERSUS DEFLECTION ANGLES,
TO BE USED FOR OTHER FULL SCALE INPUT LEVELS.**

TOTAL DEFLECTION	HORIZONTAL/VERTICAL ON AXIS INPUTS	HORIZONTAL/VERTICAL OFF AXIS INPUTS	REF IN
20°	.8V PEAK F.S.	.95V PEAK F.S.	-.65V
30°	.8V PEAK F.S.	.90V PEAK F.S.	-1.00V
40°	.8V PEAK F.S.	.85V PEAK F.S.	-1.30V
50°	.8V PEAK F.S.	.85V PEAK F.S.	-1.60V
60°	.8V PEAK F.S.	.85V PEAK F.S.	-1.80V
70°	.8V PEAK F.S.	.85V PEAK F.S.	-1.95V
80°	.8V PEAK F.S.	.85V PEAK F.S.	-2.10V
90°	.8V PEAK F.S.	.85V PEAK F.S.	-2.20V

TYPICAL APPLICATION CIRCUIT - FOCUS

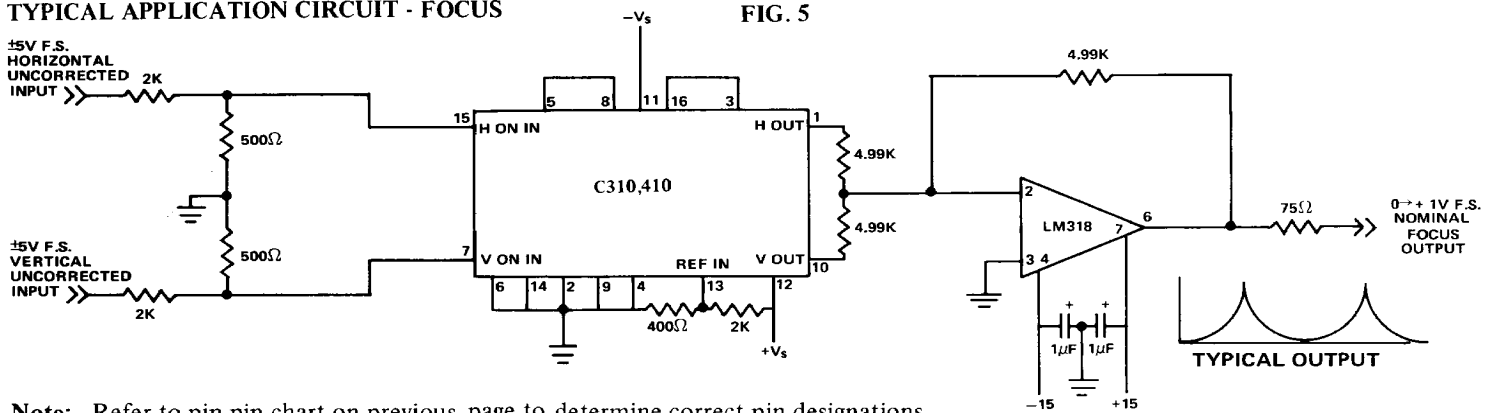

Note: Refer to pin-pin chart on previous page to determine correct pin designations.
Pins shown above are for C300 series.

NOTES:

- IF WIDER BANDWIDTH IS DESIRED USE INTRONICS A560 OR A504 IN PLACE OF LM318.

RESULTING CORRECTED SIGNAL

	LM318	A504
BANDWIDTH	2MHz	10MHz
SLEW RATE	10V/μs	200V/μs
SETTLING TO 1%	1μs	100ns

- WHEN USING C410, 411 DELETE R7 AND USE THE FOLLOWING VALUES:

20°	750*Ω//156Ω±10%
30°	750*Ω//270Ω±10%
40°	750*Ω//392Ω±10%
50°	750*Ω//547Ω±10%
60°	750*Ω//676Ω±10%
70°	750*Ω//790Ω±10%
80°	750*Ω//924Ω±10%
90°	750*Ω//1142Ω±10%

* 3600 PPM wire wound resistor (Available from KRL Electronics or equivalent).

OFF AXIS AND NON-ORTHOGONAL GUNS

IF THE ADJUSTMENTS DETAILED ABOVE WERE NOT SUFFICIENT TO CORRECT FOR SYSTEM ERRORS BECAUSE A GUN IS OFF AXIS IN EXCESS OF 5° OR NOT 90° WITH RESPECT TO THE OTHER, CALL OR WRITE FOR APPLICATION NOTES. THESE ERRORS CAN BE CORRECTED EASILY WITH THE C310 OR C410 SERIES.

FIG. 6

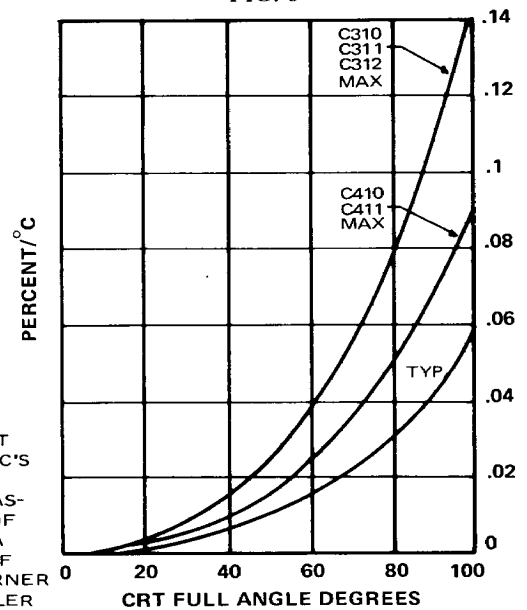

FIG. 6 SYSTEM TEMP—ERATURE DRIFT USING INTRONICS A560 SUMMING AMPLIFIER MEASURED AT END OF EACH AXIS AS A PERCENTAGE OF FULL AXIS, CORNER DRIFT IS SMALLER

016477 X X