HD66727

(Low-Power Dot-Matrix Liquid Crystal Display Controller/Driver
with Key Scan Function)

HITACHI

ADE-207-311(Z)
'99.9
Rev. 0.0

Description

The HD66727, dot-matrix liquid crystal display controller and driver LSI incorporating a key scan function, displays alphanumerics, katakana, hiragana, and symbols. It can be configured to drive a dot-matrix liquid crystal display and control key scan functions under the control of an I²C bus or a clock-synchronized serial microprocessor. A single HD66727 is capable of displaying up to four 12-character lines, 40 segments, and 12 annunciators, and controlling up to a 4-by-8 key matrix, and driving three LED. The HD66727 incorporates all the functions required for driving a dot-matrix liquid crystal display such as display RAM, character generator, and liquid crystal drivers, and it also incorporates a booster for the LCD power supply and key scan functions.

The HD66727 provides various functions to reduce the power consumption of an LCD system such as low-voltage operation of 2.4V or less, a booster for generating a maximum of triple LCD drive voltage from the supplied voltage, and voltage-followers for decreasing the direct current flow in the LCD drive bleeder-resistors. Combining these hardware functions with software functions such as standby and sleep modes allows a fine power control. The HD66727, with the above functions, is suitable for any portable battery-driven product requiring long-term driving capabilities and small size.

Features

- Control and drive of a dot-matrix LCD with built-in key scan functions
- Four 12-character lines, 40 segments, and 12 annunciators
- Control of up to a 4 × 8-key matrix, 3 LED ports and 3 general ports
- Low-power operation support:
 - 2.4 to 5.5V (low voltage)
 - Double or triple booster for liquid crystal drive voltage
 - Contrast adjuster and voltage followers for decreasing the direct current flow in the LCD drive bleeder-resistors
 - Standby mode and sleep mode
 - Displays up to 12 static annunciators
- I²C bus or clock-synchronized serial interface
- 60 × 8-bit display data RAM (60 characters max)

HITACHI

HD66727

- 11,520-bit character generator ROM
 - 240 characters (6 × 8 dots)
- 32 × 6-bit character generator RAM
 - 4 characters (6 × 8 dots)
- 8 × 6-bit segment RAM
 - 40 segment-icons and marks max
- 60-segment × 34-common liquid crystal display driver
- Programmable display sizes and duty ratios (see Table 1)
- Vertical smooth scroll
- Vertical double-height display of all character fonts
- Horizontal double display with dedicated character fonts (6-dot font width used)
- Wide range of instruction functions:
 - Clear display, display on/off control, icon and mark control, character blink, white-black inverting blinking cursor, icon and mark blink, return home, cursor on/off, white-black inverting raster-row
- Internal oscillation with an external resistor
- Hardware reset
- Wide range of LCD drive voltages
 - 3.0V to 13.0V
- Slim chip with bumps for chip-on-glass (COG) mounting, slim chip without bumps for chip-on-board (COB) mounting, and tape carrier package (TCP) (under development)

Table 1 Programmable Display Sizes and Duty Ratios

Display Size	Duty Ratio	Oscillation Frequency	Current Consumption	Multi-plexed-Drive Segments	Static-Drive Annunciators	Scanned Keys	LED Drive	General Port
1 line × 12 characters	1/10	40 kHz	8 μA	40	12	32 (4 × 8)	3	3
2 lines × 12 characters	1/18	80 kHz	15 μA	40	12	32 (4 × 8)	3	3
3 lines × 12 characters	1/26	120 kHz	23 μA	40	12	32 (4 × 8)	3	3
4 lines × 12 characters	1/34	160 kHz	30 μA	40	12	32 (4 × 8)	3	3

Note: Current consumption excludes that for LCD power supply source; $V_{CC} = 3V$.

Type Name

Type Name	External Dimension	Operation Voltage	Internal Font
HD66727A03TA0L	TCP	2.4V to 5.5V	Japanese and European fonts
HCD66727A03	Bare chip		
HCD66727A03BP	Au-bumped chip		
HD66727A04TA0L	TCP	2.4V to 5.5V	PHS & Pager fonts
HCD66727A04	Bare chip		
HCD66727A04BP	Au-bumped chip		

HD66727

LCD-II Family Comparison

Item	LCD-II (HD44780U)	HD66702R	HD66710	HD66712U
Power supply voltage	2.7V to 5.5V	5V ± 10% (standard) 2.7 V to 5.5V (low voltage)	2.7V to 5.5V	2.7V to 5.5V
Liquid crystal drive voltage	3.0 to 11.0V	3.0V to 8.3V	3.0 to 13.0V	2.7 to 11.0V
Maximum display - characters per chip	8 characters × 2 lines	20 characters × 2 lines	16 characters × 2 lines/ 8 characters × 4 lines	24 characters × 2 lines/ 12 characters × 4 lines
Segment display	None	None	40	60 (extended to 80)
Display duty ratio	1/8, 1/11, and 1/16	1/8, 1/11, and 1/16	1/17 and 1/33	1/17 and 1/33
CGROM	9,920 bits (208 5-x-8 dot characters and 32 5-x-10 dot characters)	7,200 bits (160 5-x-7 dot characters and 32 5-x-10 dot characters)	9,600 bits (240 5-x-8 dot characters)	9,600 bits (240 5-x-8 dot characters)
CGRAM	64 bytes	64 bytes	64 bytes	64 bytes
DDRAM	80 bytes	80 bytes	80 bytes	80 bytes
SEGRAM	None	None	8 bytes	16 bytes
Segment signals	40	100	40	60
Common signals	16	16	33	34
Liquid crystal drive waveform	A	B	B	B
Clock source	External resistor or external clock	External resistor or external clock	External resistor or external clock	External resistor or external clock
Rf oscillation frequency	270 kHz ± 30%	320 kHz ± 30%	270 kHz ± 30%	270 kHz ± 30%
Liquid crystal voltage booster circuit	None	None	Double or triple booster circuit	Double or triple booster circuit
Liquid crystal drive operational amplifier	None	None	None	None
Bleeder-resistor for liquid crystal drive	External	External	External	External
Liquid crystal contrast adjuster	None	None	None	None
Key scan circuit	None	None	None	None
Extension driver control signal	Independent control signal	Independent control signal	Used in common with a driver output pin	Independent control signal
Reset function	Internal reset circuit	Internal reset circuit	Internal reset circuit	Internal reset circuit or reset input
Horizontal smooth scroll	Impossible	Impossible	Dot unit	Dot unit and line unit
Vertical smooth scroll	Impossible	Impossible	Impossible	Impossible
Number of displayed lines	1 or 2	1 or 2	1, 2, or 4	1, 2, or 4
Low power control	None	None	Low power mode	Low power mode
Bus interface	4 or 8 bits	4 or 8 bits	4 or 8 bits	Serial, 4, or 8 bits
Package	80-pin QFP1420 80-pin TQFP1414 80-pin bare chip	144-pin FQFP2020 144-pin bare chip	100-pin QFP1420 100-pin TQFP1414 100-pin bare chip	128-pin TCP 128-pin bare chip

HITACHI

LCD-II Family Comparison (cont)

Item	HD66720	HD66717	HD66727
Power supply voltage	2.7V to 5.5V	2.4V to 5.5V	2.4V to 5.5V
Liquid crystal drive voltage	3.0 to 11.0V	3.0 to 13.0V	3.0 to 13.0V
Maximum display characters per chip	10 characters × 1 line/ 8 characters × 2 lines	12 characters × 1 line/2 lines/3 lines/4 lines	12 characters × 1 line/2 lines/3 lines/4 lines
Segment display	42 (extended to 80)	40 (and 10 annunciators)	40 (and 12 annunciators)
Display duty ratio	1/9 and 1/17	1/10, 1/18, 1/26, and 1/34	1/10, 1/18, 1/26, and 1/34
CGROM	9,600 bits (240 5-x-8 dot characters)	9,600 bits (240 5-x-8 dot characters)	11,520 bits (240 6-x-8 dot characters)
CGRAM	64 bytes	32 bytes	32 bytes
DDRAM	40 bytes	60 bytes	60 bytes
SEGRAM	16 bytes	8 bytes	8 bytes
Segment signals	42	60	60
Common signals	17	34	34
Liquid crystal drive waveform	B	B	B
Clock source	External resistor or external clock	External resistor or external clock	External resistor or external clock
Rf oscillation frequency	160 kHz ± 30%	1-line mode: 40 kHz ± 30% 2-line mode: 80 kHz ± 30% 3-line mode: 120 kHz ± 30% 4-line mode: 160 kHz ± 30%	1-line mode: 40 kHz ± 30% 2-line mode: 80 kHz ± 30% 3-line mode: 120 kHz ± 30% 4-line mode: 160 kHz ± 30%
Liquid crystal voltage booster circuit	Double or triple booster circuit	Double or triple booster circuit	Double or triple booster circuit
Liquid crystal drive operational amplifier	None	Built-in for each V1 to V5	Built-in for each V1 to V5
Bleeder-resistor for liquid crystal drive	External	Internal 1/4 and 1/6 bias resistors	Internal 1/4 and 1/6 bias resistors
Liquid crystal contrast adjuster	None	Incorporated	Incorporated
Key scan circuit	5 × 6 = 30 keys	None	4 × 8 = 32 keys
Extension driver control signal	Independent control signal	None	None
Reset function	Internal reset circuit or reset input	Reset input	Reset input
Horizontal smooth scroll	Dot unit and line unit	Impossible	Impossible
Vertical smooth scroll	Impossible	Dot (raster-row) unit	Dot (raster-row) unit
Number of displayed lines	1 or 2	1, 2, 3, or 4	1, 2, 3, or 4
Low power control	Low power mode and sleep mode	Standby mode and sleep mode	Standby mode and sleep mode
Bus interface	Serial	I ² C, serial, 4, or 8 bits	I ² C or clock-synchronized serial
Package	100-pin QFP1420 100-pin TQFP1414 100-pin bare chip	Slim chip with/without bumps TCP	Slim chip with/without bumps TCP

HD66727

HD66727 Block Diagram

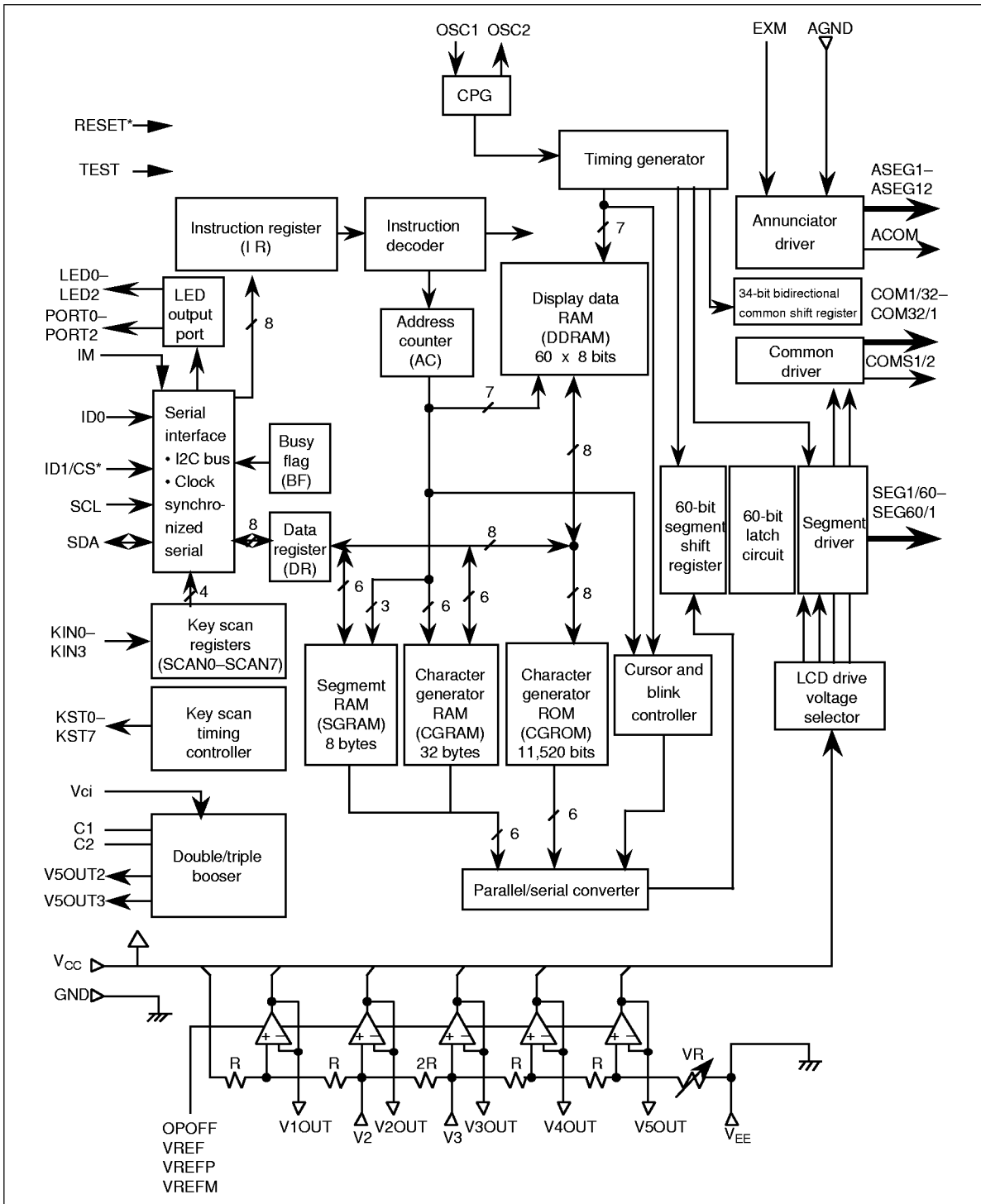

HITACHI

HD66727 Pad Coordinates

No.	Pad Name	X	Y	No.	Pad Name	X	Y	No.	Pad Name	X	Y	No.	Pad Name	X	Y
—	DUM1	-5446	-1244	46	KIN1	1737	-1173	88	ASEG3	4212	1191	136	SEG39/22	-1905	1196
1	V _{CC}	-5146	-1244	47	KIN2	1904	-1173	89	ASEG4	4088	1191	137	SEG40/21	-2029	1196
2	V _{CC}	-5022	-1244	48	KIN3	2071	-1173	90	ASEG5	3963	1191	138	SEG41/20	-2153	1196
3	V _{CC}	-4898	-1244	49	KST0	2261	-1173	91	ASEG6	3839	1191	139	SEG42/19	-2278	1196
—	DUM2	-4648	-1244	50	KST1	2421	-1173	92	ASEG7	3714	1191	140	SEG43/18	-2402	1196
—	DUM3	-4524	-1244	51	KST2	2581	-1173	93	ASEG8	3590	1191	141	SEG44/17	-2527	1196
4	V1OUT	-4336	-1169	52	KST3	2740	-1173	94	ASEG9	3465	1191	142	SEG45/16	-2651	1196
5	V2OUT	-4216	-1169	53	KST4	2900	-1173	95	ASEG10	3341	1191	143	SEG46/15	-2776	1196
6	V3OUT	-4095	-1169	54	KST5	3060	1173	96	ASEG11	3217	1191	144	SEG47/14	-2900	1196
7	V4OUT	-3975	-1169	55	KST6	3220	-1173	97	ASEG12	3092	1191	145	SEG48/13	-3024	1196
8	V5OUT	-3855	-1169	56	KST7	3380	-1173	98	SEG1/60	2824	1196	146	SEG49/12	-3149	1196
9	VREFP	-3734	-1169	57	IRQ*	3539	-1173	99	SEG2/59	2700	1196	147	SEG50/11	-3273	1196
10	VREF	-3614	-1169	58	LED0	3716	-1173	100	SEG3/58	2575	1196	148	SEG51/10	-3398	1196
11	VREFM	-3494	-1169	59	LED1	3876	-1173	101	SEG4/57	2451	1196	149	SEG52/9	-3522	1196
12	V2	-3373	-1169	60	LED2	4036	-1173	102	SEG5/56	2326	1196	150	SEG53/8	-3647	1196
13	V3	-3253	-1169	61	PORT0	4228	-1173	103	SEG6/55	2202	1196	151	SEG54/7	-3771	1196
14	V _{EE}	-3106	-1168	62	PORT1	4403	-1173	104	SEG7/54	2078	1196	152	SEG55/6	-3896	1196
15	V _{EE}	2985	-1168	63	PORT2	4578	-1173	105	SEG8/53	1953	1196	153	SEG56/5	-4020	1196
16	V5OUT3	-2829	-1168	64	GND	4735	-1201	106	SEG9/52	1829	1196	154	SEG57/4	-4144	1196
17	V5OUT3	-2708	-1168	65	GND	4855	-1201	107	SEG10/51	1704	1196	155	SEG58/3	-4269	1196
18	V5OUT2	-2528	-1168	66	GND	5054	-1201	108	SEG11/50	1580	1196	156	SEG59/2	-4393	1196
19	V5OUT2	-2407	-1168	67	AGND	5263	-1201	109	SEG12/49	1455	1196	157	SEG60/1	-4518	1196
20	C1	-2216	-1168	—	DUM4	5446	-1201	110	SEG13/48	1331	1196	—	DUM10	-4773	1260
21	C1	-2095	-1168	68	COM16/17	5446	-1020	111	SEG14/47	1206	1196	—	DUM11	-4898	1260
22	C1	-1975	-1168	69	COM15/18	5446	-896	112	SEG15/46	1082	1196	—	DUM12	-5022	1260
23	C2	-1822	-1168	70	COM14/19	5446	-772	113	SEG16/45	958	1196	—	DUM13	-5146	1260
24	C2	-1701	-1168	71	COM13/20	5446	-647	114	SEG17/44	833	1196	—	DUM14	-5446	1260
25	C2	-1580	-1168	72	COM12/21	5446	-523	115	SEG18/43	709	1196	158	COM17/16	-5446	970
26	VCI	-1389	-1168	73	COM11/22	5446	-398	116	SEG19/42	584	1196	159	COM18/15	-5446	845
27	VCI	-1268	-1168	74	COM10/23	5446	-274	117	SEG20/41	460	1196	160	COM19/14	-5446	721
28	GND	-1083	-1168	75	COM9/24	5446	-149	118	SEG21/40	335	1196	161	COM20/13	-5446	596
29	GND	-962	-1168	76	COM8/25	5446	-25	119	SEG22/39	211	1196	162	COM21/12	-5446	472
30	V _{CC}	-792	-1168	77	COM7/26	5446	100	120	SEG23/38	87	1196	163	COM22/11	-5446	348
31	V _{CC}	-672	-1168	78	COM6/27	5446	224	121	SEG24/37	-38	1196	164	COM23/10	-5446	223
32	OSC2	-459	-1173	79	COM5/28	5446	348	122	SEG25/36	-162	1196	165	COM24/9	-5446	99
33	OSC1	-315	-1173	80	COM4/29	5446	473	123	SEG26/35	-287	1196	166	COM25/8	-5446	-26
34	EXM	-148	-1173	81	COM3/30	5446	597	124	SEG27/34	-411	1196	167	COM26/7	-5446	-150
35	OPOFF	19	-1173	82	COM2/31	5446	722	125	SEG28/33	-536	1196	168	COM27/6	-5446	-275
36	TEST	185	-1173	83	COM1/32	5446	846	126	SEG29/32	-660	1196	169	COM28/5	-5446	-399
37	RESET*	352	-1173	84	COMS2/S1	5446	971	127	SEG30/31	-785	1196	170	COM29/4	-5446	-524
38	IM	519	-1173	—	DUM5	5446	1246	128	SEG31/30	-909	1196	171	COM30/3	-5446	-648
39	VCCDUM1	666	-1173	—	DUM6	5194	1246	129	SEG32/29	-1033	1196	172	COM31/2	-5446	-772
40	ID0	789	-1173	—	DUM7	5070	1246	130	SEG33/28	-1158	1196	173	COM32/1	-5446	-897
41	VCCDUM2	937	-1173	—	DUM8	4945	1246	131	SEG34/27	-1282	1196	174	COMS1/S2	-5446	-1021
42	ID1	1059	-1173	—	DUM9	4821	1246	132	SEG35/26	-1407	1196				
43	SCL	1226	-1173	85	ACOM1	4585	1191	133	SEG36/25	-1531	1196				
44	SDA	1392	-1173	86	ASEG1	4461	1191	134	SEG37/24	-1656	1196				
45	KIN0	1571	-1173	87	ASEG2	4337	1191	135	SEG38/23	-1780	1196				

HD66727

HD66727 Pad Arrangement

Chip size: 11.39 μm \times 2.89 μm
 Pad coordinates: Pad center
 Coordinate origin: Chip center
 Pad pitch: 120 μm
 Al pad size: 90 μm \times 90 μm
 Au bump size: 70 μm \times 70 μm

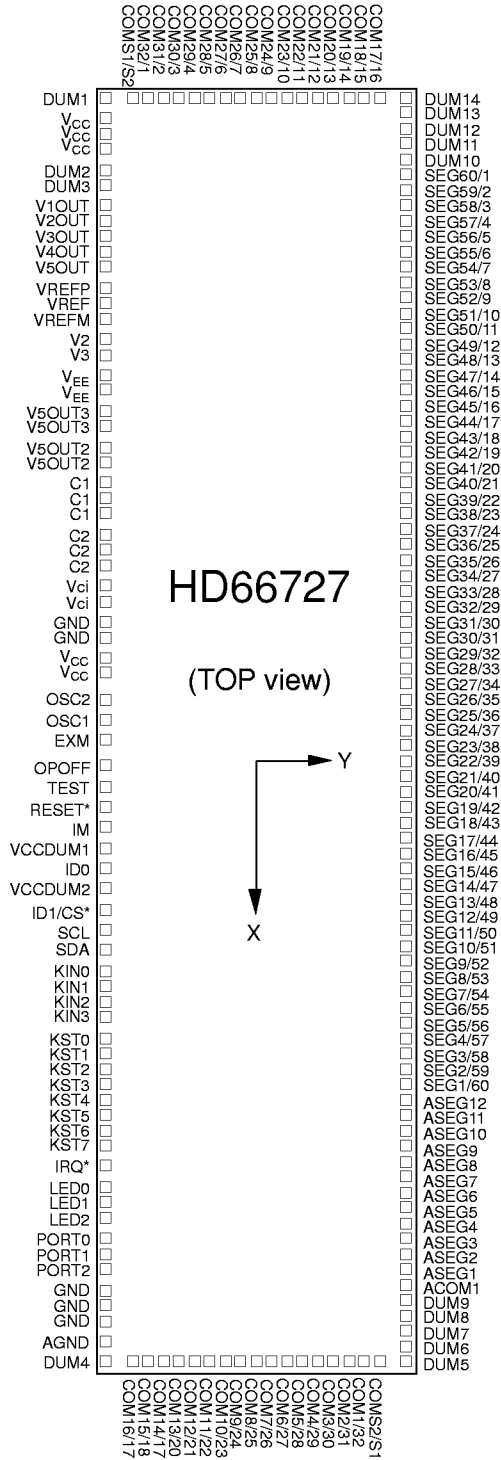

Chip-on-Glass (COG) Mounting and Routing Examples

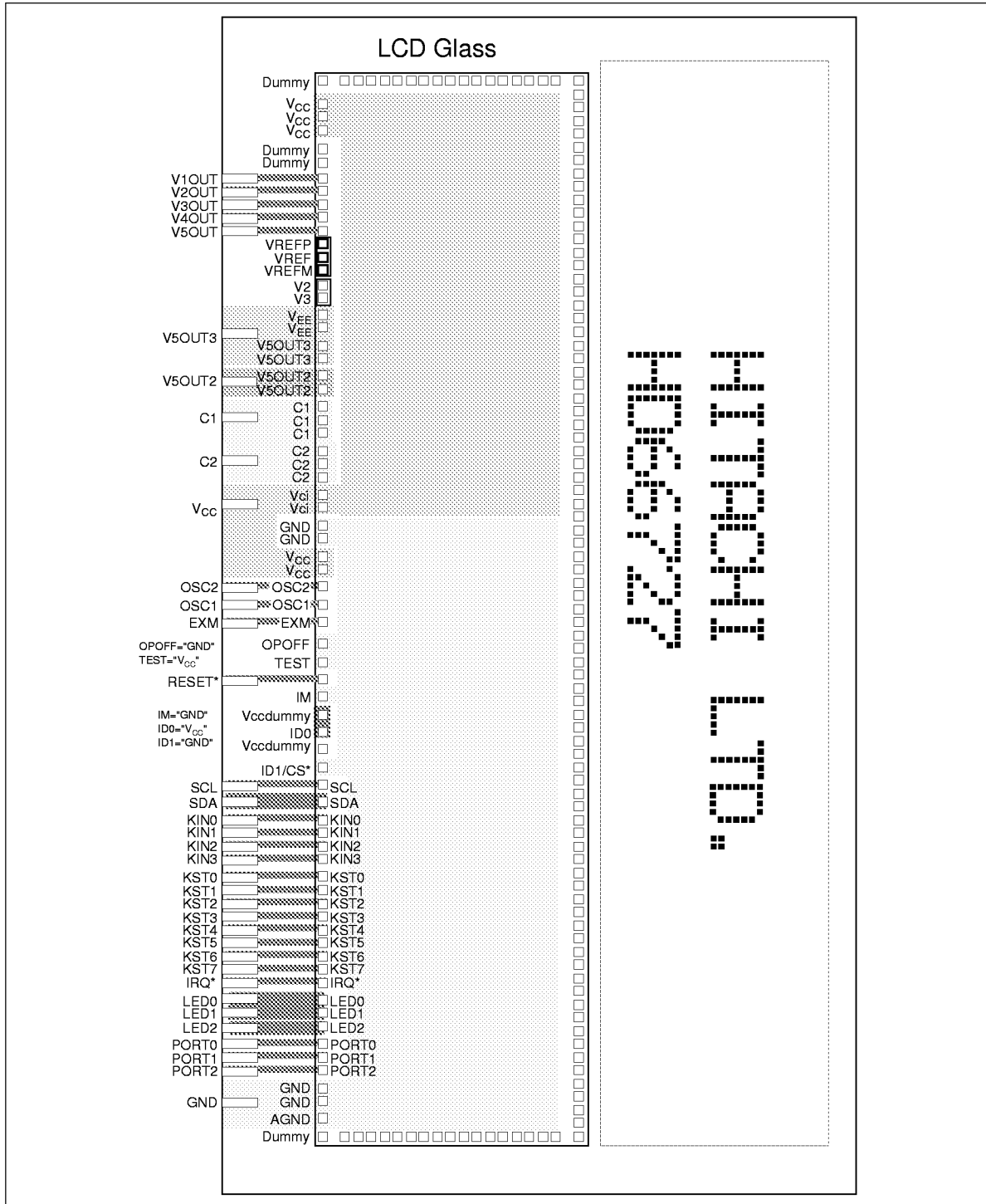

HD66727

TCP Dimensions

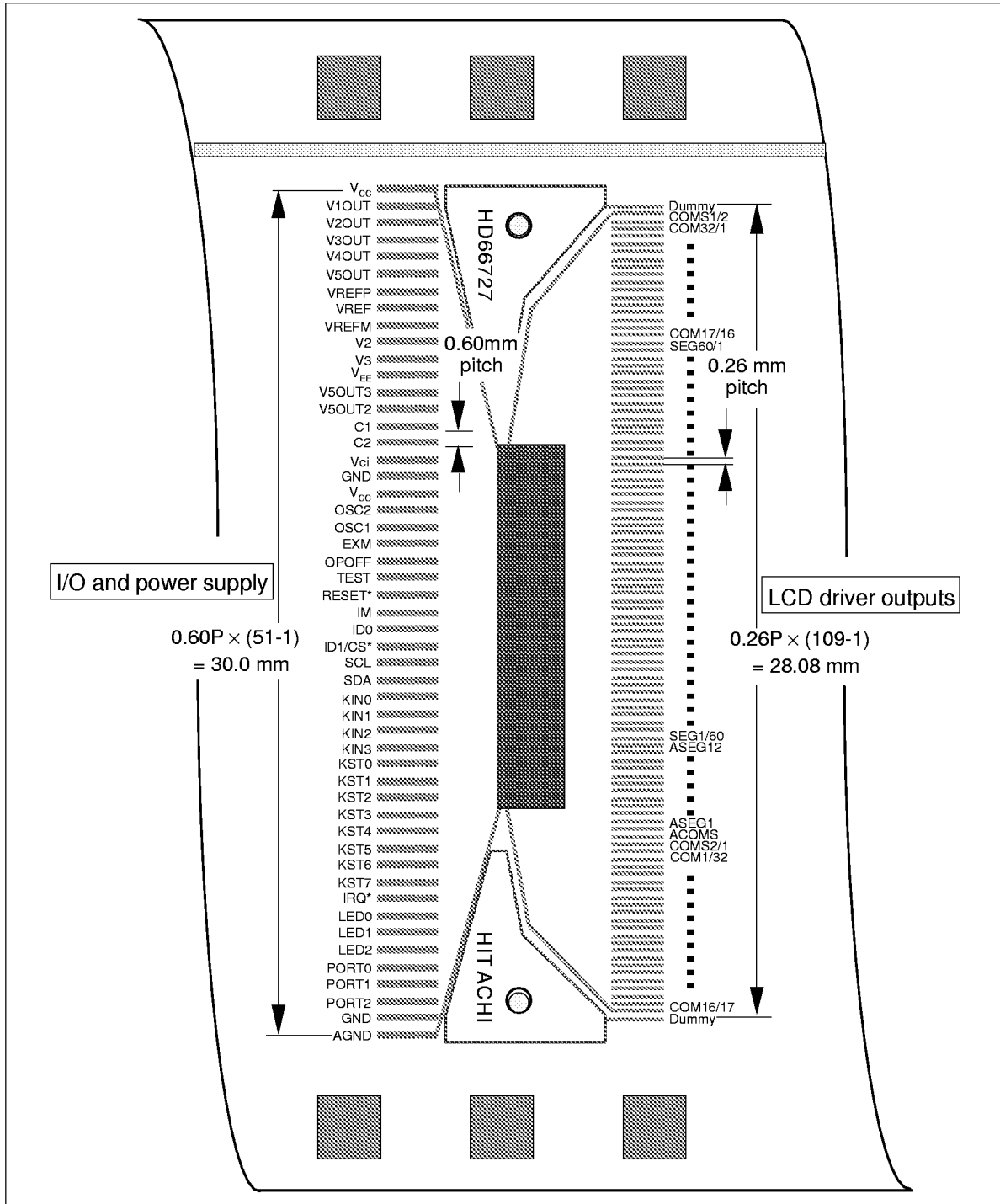

HITACHI

HD66727 Mounting Variations and Key-Matrix Configurations

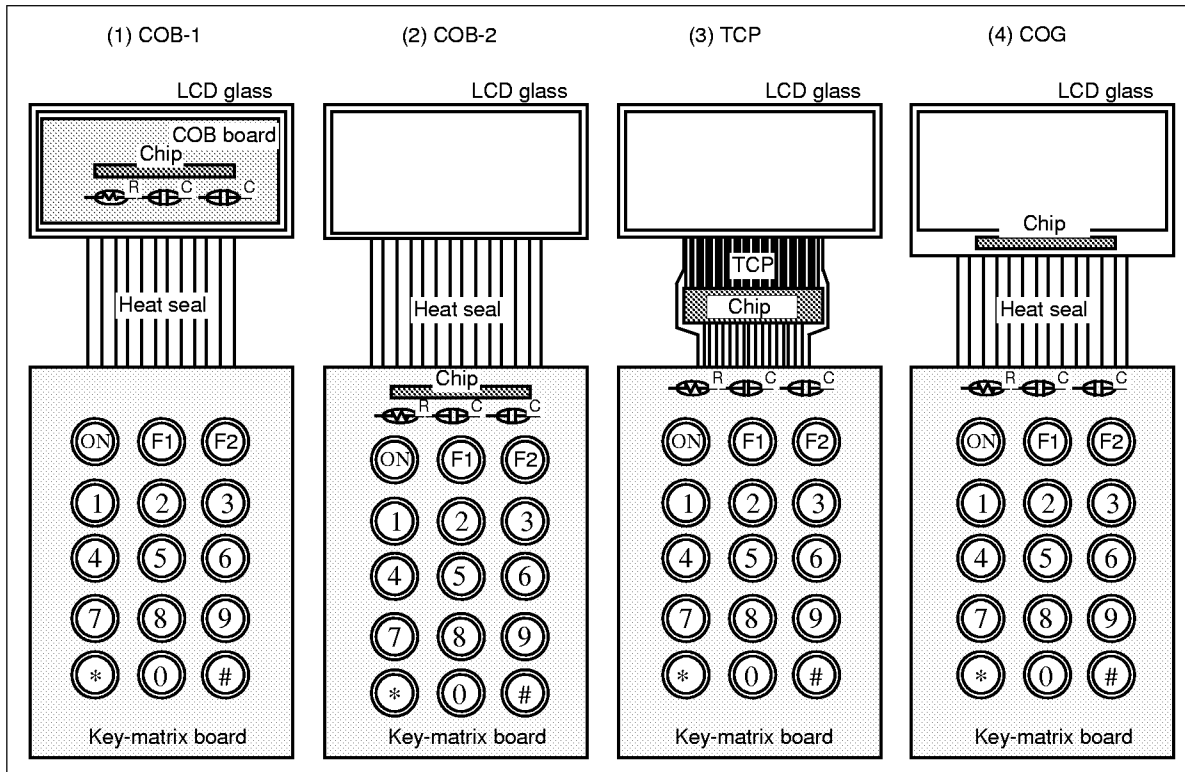

Figure 1 HD66727 Mounting Variations

Table 2 Configurations of LCD Modules (LCM) with Key Scan Function for Different Mounting Methods

Parts	Chip-on-Board (COB) Mounting 1	Chip-on-Board (COB) Mounting 2	Tape-Carrier-Package (TCP) Mounting	Chip-on-Glass (COG) Mounting
LCD glass	Necessary	Necessary	Necessary	Necessary
LCM (COB) substrate	Necessary	Not necessary	Not necessary	Not necessary
HD66727 package	Bare chip	Bare chip	TCP	Bumped chip
Heat seal	Necessary	Necessary	Optional	Necessary
Key matrix substrate	Necessary	Necessary	Necessary	Necessary

HD66727

Pin Functions

Table 3 Pin Functional Description

Signal	Number of Pins	I/O	Connected to	Function
IM	1	I	V _{CC} or GND	Selects the MPU interface mode: Low: I ² C bus mode High: Clock-synchronized serial mode
ID1/ CS*	1	I	ID1: V _{CC} or GND CS*: MPU	Inputs the HD66727's identification code (ID1) in the I ² C bus mode. Selects the HD66727 in the clock-synchronized serial mode: Low: HD66727 is selected and can be accessed High: HD66727 is not selected and cannot be accessed
SDA	1	I/O	MPU	Inputs/outputs serial (receive/transmit) data and outputs the acknowledge bit in the I ² C bus mode. Inputs/outputs serial (receive/transmit) data in the clock-synchronized serial mode.
SCL	1	I	MPU	Inputs serial clock pulses. Serial data is latched at the rising edge of each clock pulse.
ID0	1	I	V _{CC} or GND	Inputs the HD66727's identification code in both interface modes; must be fixed to high or low.
IRQ*	1	O	MPU	Generates the key scan interrupt signal.
KST0–KST7	8	O	Key matrix	Generates strobe signals for latching scanned data from the key matrix at specific time interval.
KIN0–KIN3	4	I	Key matrix	Samples key state from key matrix synchronously with strobe signals.
LED0–LED2	3	O	LED back light	Output ports for control of LED or back light. Can draw 2 mA–3 mA sink current. Also used as general ports.
PORT0–PORT2	3	O	General output	General output ports. These ports cannot drive current such as LED control.
COMS1/2, COMS2/1	2	O	LCD	Common output signals for segment-icon display.
COM1/32–COM32/1	32	O	LCD	Common output signals for character display: COM1 to COM8 for the first line; COM9 to COM16 for the second line, COM17 to COM24 for the third line, and COM25 to COM32 for the fourth line. All the unused pins output deselection waveforms. In the sleep mode (SLP = 1) or standby mode (STB = 1), all pins output V _{CC} level. The CMS bit can change the shift direction of the common signal. For example, if CMS = 0, COM1/32 is COM1. If CMS = 1, COM1/32 is COM32.

Table 3 Pin Functional Description (cont)

Signal	Number of Pins	I/O	Connected to	Function										
SEG1/60– SEG60/1	60	O	LCD	Segment output signals for segment-icon display and character display. In the sleep mode (SLP = 1) or standby mode (STB = 1), all pins output V_{CC} level. The SGS bit can change the shift direction of the segment signal. For example, if SGS = 0, SEG1/60 is SEG1. If SGS = 1, SEG1/60 is SEG60.										
ACOM	1	O	LCD	Common output signal for annunciator display; can drive display statically between V_{CC} and AGND levels; outputs V_{CC} level while annunciator display is turned off (DA = 0).										
ASEG1– ASEG12	12	O	LCD	Segment output signals for annunciator display; can drive display statically between V_{CC} and AGND levels; output V_{CC} level while annunciator display is turned off (DA = 0).										
V2, V3	2	I	Open or short-circuited	V2 and V3 are voltage levels for the internal operational amplifiers; can drive LCD with 1/4 bias when V2 and V3 are short-circuited and with 1/6 bias when they are left disconnected.										
VREFP, VREF, VREFM	3	I	Open or short-circuited	Adjusts the driving capability of the internal operational amplifiers according to the LCD power supply voltage.										
				<table border="1"> <thead> <tr> <th>LCD Power Supply Voltage ($V_{CC}-V_{EE}$)</th> <th>Pin Settings VREF, VREFP, and VREFM</th> </tr> </thead> <tbody> <tr> <td>$V_{CC}-V_{EE}$: 3V–5V</td> <td>Only VREF and VREFP shorted</td> </tr> <tr> <td>$V_{CC}-V_{EE}$: 4V–6V</td> <td>All pins open</td> </tr> <tr> <td>$V_{CC}-V_{EE}$: 5V–8V</td> <td>All pins shorted</td> </tr> <tr> <td>$V_{CC}-V_{EE}$: 7V or more</td> <td>Only VREF and VREFM shorted</td> </tr> </tbody> </table>	LCD Power Supply Voltage ($V_{CC}-V_{EE}$)	Pin Settings VREF, VREFP, and VREFM	$V_{CC}-V_{EE}$: 3V–5V	Only VREF and VREFP shorted	$V_{CC}-V_{EE}$: 4V–6V	All pins open	$V_{CC}-V_{EE}$: 5V–8V	All pins shorted	$V_{CC}-V_{EE}$: 7V or more	Only VREF and VREFM shorted
LCD Power Supply Voltage ($V_{CC}-V_{EE}$)	Pin Settings VREF, VREFP, and VREFM													
$V_{CC}-V_{EE}$: 3V–5V	Only VREF and VREFP shorted													
$V_{CC}-V_{EE}$: 4V–6V	All pins open													
$V_{CC}-V_{EE}$: 5V–8V	All pins shorted													
$V_{CC}-V_{EE}$: 7V or more	Only VREF and VREFM shorted													
V1OUT– V5OUT	5	I or O	Open or external bleeder-resistor	Used for output from the internal operational amplifiers when they are used (OPOFF = GND); when amplifiers' driving capability is insufficient, attach a capacitor to stabilize the output. Especially these capacitors for V1OUT and V4OUT must be attached in 1/26 duty and 1/34 duty. When the amplifiers are not used (OPOFF = V_{CC}), V1 to V5 voltages can be supplied to these pins externally.										
V_{EE}	2	—	Power supply	GND power supply for LCD drive. $V_{CC} - V_{EE} \leq 13V$.										
V_{CC} , GND	8	—	Power supply	V_{CC} : +2.4V to +5.5V; GND (logic): 0V										
AGND	1	—	Power supply	Low level power supply for annunciator display; can adjust contrast of annunciators; $AGND \geq GND$.										
OSC1, OSC2	2	—	Oscillation-resistor or clock	For R-C oscillation, connect an external resistor. For external clock supply, input clock pulses to OSC1.										

HD66727

Table 3 Pin Functional Description (cont)

Signal	Number of Pins	I/O	Connected to	Function
Vci	2	I	Power supply	Inputs a reference voltage and supplies power to the booster; generates the liquid crystal display drive voltage from the operating voltage. $V_{ci} = 1.0V \text{ to } 5.0V \leq V_{cc}$
V5OUT2	3	O	V_{EE} pin/booster capacitance	Voltage input to the Vci pin is boosted twice and output. When the voltage is boosted three times, the same capacitance as that of C1–C2 should be connected here.
V5OUT3	2	O	V_{EE} pin	Voltage input to the Vci pin is boosted three times and output.
C1, C2	6	—	Booster capacitance	External capacitance should be connected here when using the booster.
RESET*	1	I	MPU or external R-C circuit	Reset pin. Initializes the LSI when low. Be sure to input this signal after power-on.
EXM	1	I	MPU	External alternating signal used for annunciator display in the standby mode. If annunciator display is not used, EXM must be fixed to V_{cc} or GND.
OPOFF	1	I	V_{cc} or GND	Turns the internal operational amplifier off when OPOFF = V_{cc} , and turns it on when OPOFF = GND. If the amplifier is turned off (OPOFF = V_{cc}), V1 to V5 must be supplied to the V1OUT to V5OUT pins.
V_{cc} dummy	2	0	Input pad	Outputs V_{cc} supply level; can fix the input pads to V_{cc} level.
TEST	1	I	GND	Test pin. Must be fixed at GND level.

Block Function Description

System Interface

The HD66727 has two types of system interfaces: I²C bus and clock-synchronized serial. The interface mode is selected by the IM pin.

The HD66727 has two 8-bit registers: an instruction register (IR) and a data register (DR).

The IR stores instruction codes, such as clear display, return home, and display control, and address information for display data RAM (DDRAM), character generator RAM (CGRAM), and segment RAM (SEGRAM). The IR can only be written to by MPU and cannot be read from.

The DR temporarily stores data to be written into DDRAM, CGRAM, SEGRAM, or annunciator. Data written into the DR from the MPU is automatically written into DDRAM, CGRAM, SEGRAM, or annunciator by an internal operation. The DR is also used for data storage when reading data from DDRAM, CGRAM, or SEGRAM. When address information is written into the IR, data is read and then stored into the DR from DDRAM, CGRAM, or SEGRAM by an internal operation. Data transfer between the MPU is then completed when the MPU reads the DR. After the read, data in DDRAM, CGRAM, or SEGRAM at the next address is sent to the DR for the next read from the MPU.

These two registers and the operations can be selected by the register select bit (RS) and the read/write bit (R/W) as listed in Table 4. For details, see the Serial Data Transfer section.

Table 4 Register Selection by RS and R/W Bits

RS Bit	R/W Bit	Operation
0	0	IR write as an internal operation
0	1	Read busy flag (DB7) and key scan data (DB3 to DB0)
1	0	DR write as an internal operation (DR to DDRAM, CGRAM, SEGRAM, or annunciator)
1	1	DR read as an internal operation (DDRAM, CGRAM, or SEGRAM to DR)

Busy Flag (BF)

When the busy flag is 1, the HD66727 is in the internal operation mode, and the next instruction will not be accepted. When RS = 0 and R/W = 1, the busy flag is output from DB7. The next instruction must be written after ensuring that the busy flag is 0, or data must be transferred in appropriate timing considering instruction execution times.

HD66727

Key Scan Registers (SCAN0 to SCAN7)

The key matrix scanner senses and holds the key states at each rising edge of the key strobe signals that are output by the HD66727. The key strobe signals are output as time-multiplexed signals from KST0 to KST7. After passing through the key matrix, these strobe signals are used to sample the key status on four inputs KIN0 to KIN3, enabling up to 32 keys to be scanned.

The states of inputs KIN0 to KIN3 are sampled by key strobe signal KST0 and latched into register SCAN0. Similarly, the data sampled by strobe signals KST1 to KST7 is latched into registers SCAN1 to SCAN7, respectively.

Address Counter (AC)

The address counter (AC) assigns addresses to DDRAM, CGRAM, or SEGRAM. When the address set instruction is written into the IR, the address information is sent from the IR to the AC. Selection of DDRAM, CGRAM, and SEGRAM is also determined concurrently by the instruction. Figure 2 shows the address counter and a sample DDRAM address setting to the address counter.

After writing into (reading from) DDRAM, CGRAM, or SEGRAM, the AC is automatically incremented by 1 (or decremented by 1).

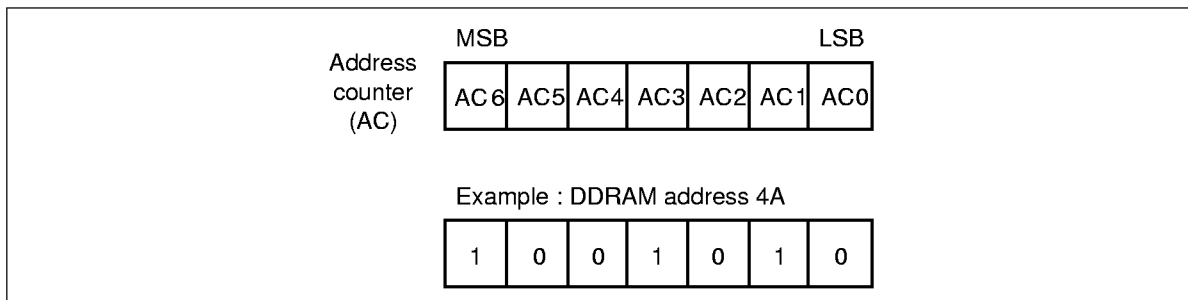

Figure 2 Address Counter and Sample DDRAM Address Setting

Display Data RAM (DDRAM)

Display data RAM (DDRAM) stores display data represented in 8-bit character codes. Its capacity is 60×8 bits, or 60 characters, which is equivalent to an area of 12 characters \times 5 lines. Any number of display lines (LCD drive duty ratio) from 1 to 4 can be selected by software. Here, assignment of DDRAM addresses is the same for all display modes (Table 5). The line to be displayed at the top of the display (display-start line) can also be selected by register settings. See Table 6.

Table 5 DDRAM Addresses and Display Positions

Display Line	1st Char.	2nd Char.	3rd Char.	4th Char.	5th Char.	6th Char.	7th Char.	8th Char.	9th Char.	10th Char.	11th Char.	12th Char.
1st	00	01	02	03	04	05	06	07	08	09	0A	0B
2nd	10	11	12	13	14	15	16	17	18	19	1A	1B
3rd	20	21	22	23	24	25	26	27	28	29	2A	2B
4th	30	31	32	33	34	35	36	37	38	39	3A	3B
5th	40	41	42	43	44	45	46	47	48	49	4A	4B

Note: Char. indicates character position.

Table 6 Display-Line Modes, Display-Start Line, and DDRAM Addresses

Display-Line Mode	Duty Ratio	Common Pins	Display-Start Lines				
			1st Line (SN = 000)	2nd Line (SN = 001)	3rd Line (SN = 010)	4th Line (SN = 011)	5th Line (SN = 100)
1-line (NL = 00)	1/10	COM1–COM8	"00"H–"0B"H	"10"H–"1B"H	"20"H–"2B"H	"30"H–"3B"H	"40"H–"4B"H
		COM9–COM16	"10"H–"1B"H	"20"H–"2B"H	"30"H–"3B"H	"40"H–"4B"H	"00"H–"0B"H
2-line (NL = 01)	1/18	COM1–COM8	"00"H–"0B"H	"10"H–"1B"H	"20"H–"2B"H	"30"H–"3B"H	"40"H–"4B"H
		COM9–COM16	"10"H–"1B"H	"20"H–"2B"H	"30"H–"3B"H	"40"H–"4B"H	"00"H–"0B"H
		COM17–COM24	"20"H–"2B"H	"30"H–"3B"H	"40"H–"4B"H	"00"H–"0B"H	"10"H–"1B"H
3-line (NL = 10)	1/26	COM1–COM8	"00"H–"0B"H	"10"H–"1B"H	"20"H–"2B"H	"30"H–"3B"H	"40"H–"4B"H
		COM9–COM16	"10"H–"1B"H	"20"H–"2B"H	"30"H–"3B"H	"40"H–"4B"H	"00"H–"0B"H
		COM17–COM24	"20"H–"2B"H	"30"H–"3B"H	"40"H–"4B"H	"00"H–"0B"H	"10"H–"1B"H
4-line (NL = 11)	1/34	COM1–COM8	"00"H–"0B"H	"10"H–"1B"H	"20"H–"2B"H	"30"H–"3B"H	"40"H–"4B"H
		COM9–COM16	"10"H–"1B"H	"20"H–"2B"H	"30"H–"3B"H	"40"H–"4B"H	"00"H–"0B"H
		COM17–COM24	"20"H–"2B"H	"30"H–"3B"H	"40"H–"4B"H	"00"H–"0B"H	"10"H–"1B"H
		COM25–COM32	"30"H–"3B"H	"40"H–"4B"H	"00"H–"0B"H	"10"H–"1B"H	"20"H–"2B"H

Character Generator ROM (CGROM)

Character generator ROM (CGROM) generates 6 × 8-dot character patterns from 8-bit character codes. It can generate 240 6 × 8-dot character patterns. Table 7 illustrates the relation between character codes and character patterns for the Hitachi standard CGROM. User-defined character patterns are also available using a mask-programmed ROM (see the Modifying Character Patterns section).

Table 7 Relation between Character Codes and Character Patterns (ROM code: A03)

Character Code	x 0	x 1	x 2	x 3	x 4	x 5	x 6	x 7	x 8	x 9	x A	x B	x C	x D	x E	x F
0 y	CGRAM (1)	CGRAM (2)	CGRAM (3)	CGRAM (4)	CGRAM (1)	CGRAM (2)	CGRAM (3)	CGRAM (4)	CGRAM (1)	CGRAM (2)	CGRAM (3)	CGRAM (4)	CGRAM (1)	CGRAM (2)	CGRAM (3)	CGRAM (4)
1 y	0	1	2	3	4	5	6	7	8	9	A	B	C	D	E	F
2 y	!	"	#	\$	%	&	'	()	*	+	,	-	.	/	
3 y	0	1	2	3	4	5	6	7	8	9	:	;	<	=	>	?
4 y	a	b	c	d	e	f	g	h	i	j	k	l	m	n	o	
5 y	p	q	r	s	t	u	v	w	x	y	z	[\]	^	_
6 y	ˆ	a	b	c	d	e	f	g	h	i	j	k	l	m	n	o
7 y	p	q	r	s	t	u	v	w	x	y	z	[\]	^	_
8 y	0	1	2	3	4	5	6	7	8	9	:	;	<	=	>	?
9 y	0	1	2	3	4	5	6	7	8	9	:	;	<	=	>	?
A y	ˆ	a	ˆ	ˆ	ˆ	ˆ	ˆ	ˆ	ˆ	ˆ	ˆ	ˆ	ˆ	ˆ	ˆ	ˆ
B y	ˆ	ˆ	ˆ	ˆ	ˆ	ˆ	ˆ	ˆ	ˆ	ˆ	ˆ	ˆ	ˆ	ˆ	ˆ	ˆ
C y	ˆ	ˆ	ˆ	ˆ	ˆ	ˆ	ˆ	ˆ	ˆ	ˆ	ˆ	ˆ	ˆ	ˆ	ˆ	ˆ
D y	ˆ	ˆ	ˆ	ˆ	ˆ	ˆ	ˆ	ˆ	ˆ	ˆ	ˆ	ˆ	ˆ	ˆ	ˆ	ˆ
E y	ˆ	ˆ	ˆ	ˆ	ˆ	ˆ	ˆ	ˆ	ˆ	ˆ	ˆ	ˆ	ˆ	ˆ	ˆ	ˆ
F y	ˆ	ˆ	ˆ	ˆ	ˆ	ˆ	ˆ	ˆ	ˆ	ˆ	ˆ	ˆ	ˆ	ˆ	ˆ	ˆ

Table 7 Relation between Character Codes and Character Patterns (ROM code: A04)

Lower Upper	x 0	x 1	x 2	x 3	x 4	x 5	x 6	x 7	x 8	x 9	x A	x B	x C	x D	x E	x F
0 y	CGRAM (1)	CGRAM (2)	CGRAM (3)	CGRAM (4)	CGRAM (1)	CGRAM (2)	CGRAM (3)	CGRAM (4)	CGRAM (1)	CGRAM (2)	CGRAM (3)	CGRAM (4)	CGRAM (1)	CGRAM (2)	CGRAM (3)	CGRAM (4)
1 y	0	1	2	3	4	5	6	7	8	9	A	B	C	D	E	F
2 y		!	@	#	\$	%	&	'	()	*	+	,	-	.	/
3 y	0	1	2	3	4	5	6	7	8	9	A	B	C	D	E	F
4 y	a	b	c	d	e	f	g	h	i	j	k	l	m	n	o	
5 y	P	R	S	T	U	V	W	X	Y	Z	[]	^	_		
6 y	a	b	c	d	e	f	g	h	i	j	k	l	m	n	o	
7 y	P	R	S	T	U	V	W	X	Y	Z	[]	^	_		
8 y	0	1	2	3	4	5	6	7	8	9	A	B	C	D	E	F
9 y	0	1	2	3	4	5	6	7	8	9	A	B	C	D	E	F
A y	a	b	c	d	e	f	g	h	i	j	k	l	m	n	o	
B y	0	1	2	3	4	5	6	7	8	9	A	B	C	D	E	F
C y	0	1	2	3	4	5	6	7	8	9	A	B	C	D	E	F
D y	0	1	2	3	4	5	6	7	8	9	A	B	C	D	E	F
E y	0	1	2	3	4	5	6	7	8	9	A	B	C	D	E	F
F y	0	1	2	3	4	5	6	7	8	9	A	B	C	D	E	F

HD66727

Character Generator RAM (CGRAM)

Character generator RAM (CGRAM) of 32×6 bits allows the user to redefine the character patterns. In the case of 6×8 -dot characters, up to four characters may be redefined.

Write the character codes at addresses “00”H to “03”H into DDRAM to display the character patterns stored in CGRAM (Table 8).

Table 8 Example of Relationships between Character Code (DDRAM) and Character Pattern (CGRAM Data)

Character code (DDRAM data)								CGRAM address					MSB		CGRAM data						LSB
D7	D6	D5	D4	D3	D2	D1	D0	A4	A3	A2	A1	A0	O7	O6	O5	O4	O3	O2	O1	O0	
0	0	0	0	*	*	0	0	0	0	0	0	0	*	*	0	1	0	0	0	1	Character pattern (1)
↓								↓					(Don't care) ↓		0	1	0	0	0	1	
															0	1	0	0	0	1	
															0	1	0	0	0	1	
															0	0	1	0	1	0	
															0	0	0	1	0	0	
															0	0	0	1	0	0	
															0	0	0	1	0	0	
															0	0	0	0	0	0	
0	0	0	0	0	0	1	1	0	0	0	*	*	0	1	0	0	0	1	Character pattern (4)		
↓								↓					(Don't care) ↓		0	1	0	0		0	1
															0	1	0	0		0	1
															0	1	0	0		0	1
															0	0	1	0		1	0
															0	0	0	1		0	0
															0	0	0	1		0	0
															0	0	0	1		0	0
															0	0	0	0	0	0	

- Notes:
- The lower 2 bits of the character code correspond to the upper two bits of the CGRAM address (2 bits: 4 types).
 - CGRAM address bits 0 to 2 designate the character pattern raster-row position. The 8th raster-row is the cursor position and its display is formed by a logical OR with the cursor.
 - In the 5-dot font width, the higher three bits of the CGRAM data are invalid; use the lower five bits (O4 to O0). In the 6-dot font width, the higher two bits are invalid.
 - When the upper four bits (bits 7 to 4) of the character code are 0, CGRAM is selected.
Bits 3 and 2 of the character code are invalid (*). Therefore, for example, the character codes 00H and 08H correspond to the same CGRAM address.
 - A set bit in the CGRAM data corresponds to display selection, and 0 to non-selection.

Segment RAM (SEGRAM)

Segment RAM (SEGRAM) is used to enable control of segments such as icons and marks by the user program. Segments and characters are driven by a multiplexing drive method.

SEGRAM has a capacity of 8×6 bits, for controlling the display of a maximum of 40 (48 in the 6-dot font width) icons and marks. While COMS1 and COMS2 outputs are being selected, SEGRAM is read and segments (icons and marks) are displayed by a multiplexing drive method (20 segments each during COMS1 and COMS2 selection).

Bits in SEGRAM corresponding to segments to be displayed are directly set by the MPU, regardless of the contents of DDRAM and CGRAM.

Tables 9 and 10 illustrate the correspondence between SEGRAM addresses and driver signals.

Table 9 Correspondence between Segment Display SEGRAM Addresses (ASEG) and Driver Signals in the 5-Dot Font Width

ASEG Address				Segment Signals							Common Signal	
MSB		LSB	D7	D6	D5	D4	D3	D2	D1	D0		
1	0	0	0	*	*	*	SEG1, SEG21, SEG41	SEG2, SEG22, SEG42	SEG3, SEG23, SEG43	SEG4, SEG24, SEG44	SEG5, SEG25, SEG45	COMS1
1	0	0	1	*	*	*	SEG6, SEG26, SEG46	SEG7, SEG27, SEG47	SEG8, SEG28, SEG48	SEG9, SEG29, SEG49	SEG10, SEG30, SEG50	COMS1
1	0	1	0	*	*	*	SEG11, SEG31, SEG51	SEG12, SEG32, SEG52	SEG13, SEG33, SEG53	SEG14, SEG34, SEG54	SEG15, SEG35, SEG55	COMS1
1	0	1	1	*	*	*	SEG16, SEG36, SEG56	SEG17, SEG37, SEG57	SEG18, SEG38, SEG58	SEG19, SEG39, SEG59	SEG20, SEG40, SEG60	COMS1
1	1	0	0	*	*	*	SEG1, SEG21, SEG41	SEG2, SEG22, SEG42	SEG3, SEG23, SEG43	SEG4, SEG24, SEG44	SEG5, SEG25, SEG45	COMS2
1	1	0	1	*	*	*	SEG6, SEG26, SEG46	SEG7, SEG27, SEG47	SEG8, SEG28, SEG48	SEG9, SEG29, SEG49	SEG10, SEG30, SEG50	COMS2
1	1	1	0	*	*	*	SEG11, SEG31, SEG51	SEG12, SEG32, SEG52	SEG13, SEG33, SEG53	SEG14, SEG34, SEG54	SEG15, SEG35, SEG55	COMS2
1	1	1	1	*	*	*	SEG16, SEG36, SEG56	SEG17, SEG37, SEG57	SEG18, SEG38, SEG58	SEG19, SEG39, SEG59	SEG20, SEG40, SEG60	COMS2

- Notes: 1. When the SFT pin is grounded, the SEG1 pin output is connected to the far left of the LCD panel, and when the SFT pin is high, the SEG60 pin output is connected to the far left.
2. SEG1 to SEG20 data is identical to SEG21 to SEG40 and SEG41 to SEG60 data.
3. The lower five bits (D4 to D0) of SEGRAM data determine on or off display of each segment. A segment is selected (turned on) when the corresponding data is 1, and is deselected (turned off) when the corresponding data is 0. The upper three bits (D7 to D5) are invalid.

HD66727

Table 10 Correspondence between Segment Display SEGRAM Addresses (ASEG) and Driver Signals in the 6-Dot Font Width

ASEG Address		Segment Signals										Common Signal
MSB	LSB	D7	D6	D5	D4	D3	D2	D1	D0			
1	0	0	0	*	*	SEG1, SEG25, SEG49	SEG2, SEG26, SEG50	SEG3, SEG27, SEG51	SEG4, SEG28, SEG52	SEG5, SEG29, SEG53	SEG6, SEG30, SEG54	COMS1
1	0	0	1	*	*	SEG7, SEG31, SEG55	SEG8, SEG32, SEG56	SEG9, SEG33, SEG57	SEG10, SEG34, SEG58	SEG11, SEG35, SEG59	SEG12, SEG36, SEG60	COMS1
1	0	1	0	*	*	SEG13, SEG37	SEG14, SEG38	SEG15, SEG39	SEG16, SEG40	SEG17, SEG41	SEG18, SEG42	COMS1
1	0	1	1	*	*	SEG19, SEG43	SEG20, SEG44	SEG21, SEG45	SEG22, SEG46	SEG23, SEG47	SEG24, SEG48	COMS1
1	1	0	0	*	*	SEG1, SEG25, SEG49	SEG2, SEG26, SEG50	SEG3, SEG27, SEG51	SEG4, SEG28, SEG52	SEG5, SEG29, SEG53	SEG6, SEG30, SEG54	COMS2
1	1	0	1	*	*	SEG7, SEG31, SEG55	SEG8, SEG32, SEG56	SEG9, SEG33, SEG57	SEG10, SEG34, SEG58	SEG11, SEG35, SEG59	SEG12, SEG36, SEG60	COMS2
1	1	1	0	*	*	SEG13, SEG37	SEG14, SEG38	SEG15, SEG39	SEG16, SEG40	SEG17, SEG41	SEG18, SEG42	COMS2
1	1	1	1	*	*	SEG19, SEG43	SEG20, SEG44	SEG21, SEG45	SEG22, SEG46	SEG23, SEG47	SEG24, SEG48	COMS2

- Notes:
1. When the SFT pin is grounded, the SEG1 pin output is connected to the far left of the LCD panel, and when the SFT pin is high, the SEG60 pin output is connected to the far left.
 2. SEG1 to SEG24 data are identical to SEG25 to SEG48 and SEG49 to SEG60 data.
 3. The lower six bits (D5 to D0) of SEGRAM data determine on or off display for each segment. A segment is selected (turned on) when the corresponding bit is 1, and is deselected (turned off) when the corresponding bit is 0. The upper two bits (D7 to D6) are invalid.

Timing Generation Circuit

The timing generation circuit generates timing signals for the operation of internal circuits such as DDRAM, CGROM, CGRAM, and SEGRAM. RAM read timing for display and internal operation timing by MPU access are generated separately to avoid interfering with each other. Therefore, when writing data to DDRAM, for example, there will be no undesirable interferences, such as flickering, in areas other than the display area.

Cursor/Blink Control Circuit

The cursor/blink (or white-black inversion) control is used to produce a cursor or a flashing area on the display at a position corresponding to the location stored in the address counter (AC).

For example (Figure 3), when the address counter is 08H, a cursor is displayed at a position corresponding to DDRAM address “08”H.

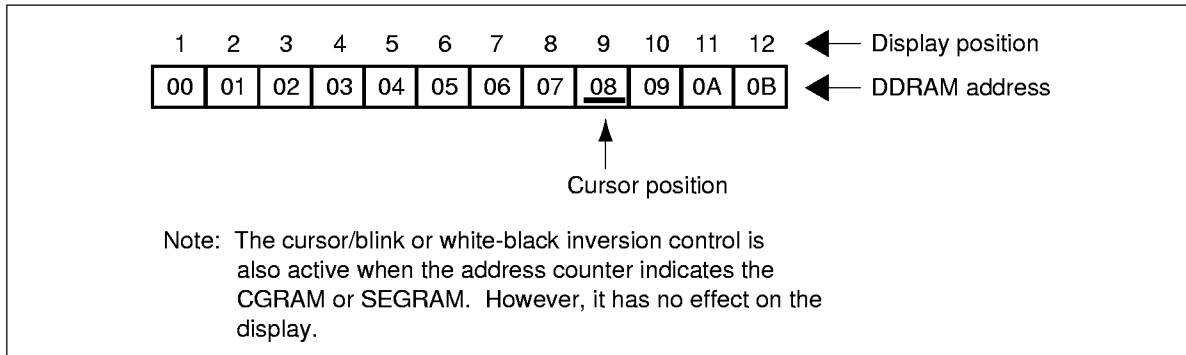

Figure 3 Cursor Position and DDRAM Address

Multiplexing Liquid Crystal Display Driver Circuit

The multiplexing liquid crystal display driver circuit consists of 34 common signal drivers (COM1 to COM32, COMS1, COMS2) and 60 segment signal drivers (SEG1 to SEG60). When the number of lines are selected by a program, the required common signal drivers automatically output drive waveforms, while the other common signal drivers continue to output deselection waveforms.

Character pattern data is sent serially through a 60-bit shift register and latched when all needed data has arrived. The latched data then enables the segment signal drivers to generate drive waveform outputs.

The shift direction of 60-bit data can be changed by the SGS bit. The shift direction of the common driver can also be changed by the CMS bit; select the direction appropriate for the device mounting configuration.

When multiplexing drive is not used, or during the standby or sleep mode, all the above common and segment signal drivers output the V_{CC} level, halting display.

Annunciator Driver Circuit

The static annunciator drivers, which are specially used for displaying icons and marks, consists of 1 common signal driver (ACOM) and 12 segment signal drivers (ASEG1 to ASEG12). Since this driver circuit operates at the logic operating voltage (V_{CC} to AGND), the LCD drive power supply circuit is not necessary, and low-power consumption can be achieved. It is suitable for mark indication during system standby because of its drive capability during the standby and sleep modes. When multiplexing drive is not used, or during the standby or sleep mode, all the above common and segment signal drivers output the V_{CC} level, halting display.

Tables 11 to 13 illustrate the correspondence between the annunciator addresses (AAN) and driver signals.

HD66727

Table 11 Correspondence between Annunciator Display Addresses (AAN) and Driver Signals

AAN Address				Annunciator Segment Signals								Common Signal
MSB	LSB			D7	D6	D5	D4	D3	D2	D1	D0	
0	0	0	0	ASEG1		ASEG2		ASEG3		ASEG4		ACOM
0	0	0	0	Blink	Data	Blink	Data	Blink	Data	Blink	Data	ACOM
0	0	0	1	ASEG5		ASEG6		ASEG7		ASEG8		ACOM
0	0	0	1	Blink	Data	Blink	Data	Blink	Data	Blink	Data	ACOM
0	0	1	0	ASEG9		ASEG10		ASEG11		ASEG12		ACOM
0	0	1	0	Blink	Data	Blink	Data	Blink	Data	Blink	Data	ACOM

- Notes: 1. The annunciator is turned on when the corresponding even bit (data) is 1, and is turned off when 0.
 2. The turned-on annunciator blinks when the corresponding odd bit (blink) is 1. Blinking is provided by repeatedly turning on the annunciator for 32 frames and then turning it off for the next 32 frames.

Table 12 Correspondence between LED Driving Port Addresses (AAN) and Driver Signals

AAN Address				LED Driving and General Output Port							
MSB	LSB			D7	D6	D5	D4	D3	D2	D1	D0
0	0	1	1	*	*	Port2	Port1	Port0	LED2	LED1	LED0
						General output port		LED driving port			

- Notes: 1. The LED bits are inverted and output from each LED pin. If 0 is set, the V_{CC} level is output from the LED pin. If 1 is set, the GND level is output from the LED pin.
 2. The port bits output from each port pin. If 0 is set, the GND level is output from the PORT pin. If 1 is set, the V_{CC} level is output from the PORT pin.
 3. Current cannot be driven for outputs of the V_{CC} level in LED2–LED0 and the V_{CC} and GND levels in PORT2–PORT0.
 4. The upper two bits (D7 and D6) are invalid.

Table 13 Correspondence between SEG/COM Addresses (AAN) and Driver Signals

AAN Address				Shift Direction of SEG/COM Driver							
MSB	LSB			D7	D6	D5	D4	D3	D2	D1	D0
0	1	0	0	*	*	*	*	*	*	CMS	SGS

- Notes: 1. If CMS = 0, COM1/32 is the first line of the first column, and COM32/1 is the 8th line of the fourth column. If CMS = 1, COM1/32 is the 8th line of the fourth column, and COM32/1 is the first line of the first column. If CMS = 0, COMS1/2 is COMS1, and COMS2/1 is COM2.
 2. If SGS = 0, SEG1/60 is SEG1 in the left of the display, and SEG60/1 is SEG60 in the right of the display. If SGS = 1, the shift direction of the SEG is reversed.
 3. The upper six bits (D7–D2) are invalid.

LED Output Port

The HD66727 includes three LED/back-light driving output ports and three general output ports. These ports can control the LED from the microcomputer through the serial interface.

Booster (DC-DC Converter)

The booster doubles or triples a voltage input to the V_{ci} pin. With this function, both the internal logic units and LCD drivers can be controlled with a single power supply.

Oscillator (OSC)

The HD66727 can provide R-C oscillation simply by adding an external oscillation-resistor between the OSC1 and OSC2 pins. The appropriate oscillation frequency for operating voltage, display size, and frame frequency can be obtained by adjusting the external-resistor value. Clock pulses can also be supplied externally. Since R-C oscillation is halted during the standby mode, current consumption can be reduced.

V-Pin Voltage Followers

A voltage follower for each voltage level (V1 to V5) reduces current consumption by the LCD drive power supply circuit. No external resistors are required because of the internal bleeder-resistor, which generates different levels of LCD drive voltage. The voltage followers can be turned off while multiplexing drive is not being used.

Contrast Adjuster

The contrast adjuster can adjust LCD contrast by varying LCD drive voltage by software. This function is suitable for selecting appropriate brightness of the LCD or for temperature compensation.

Modifying Character Patterns

Character pattern development procedure

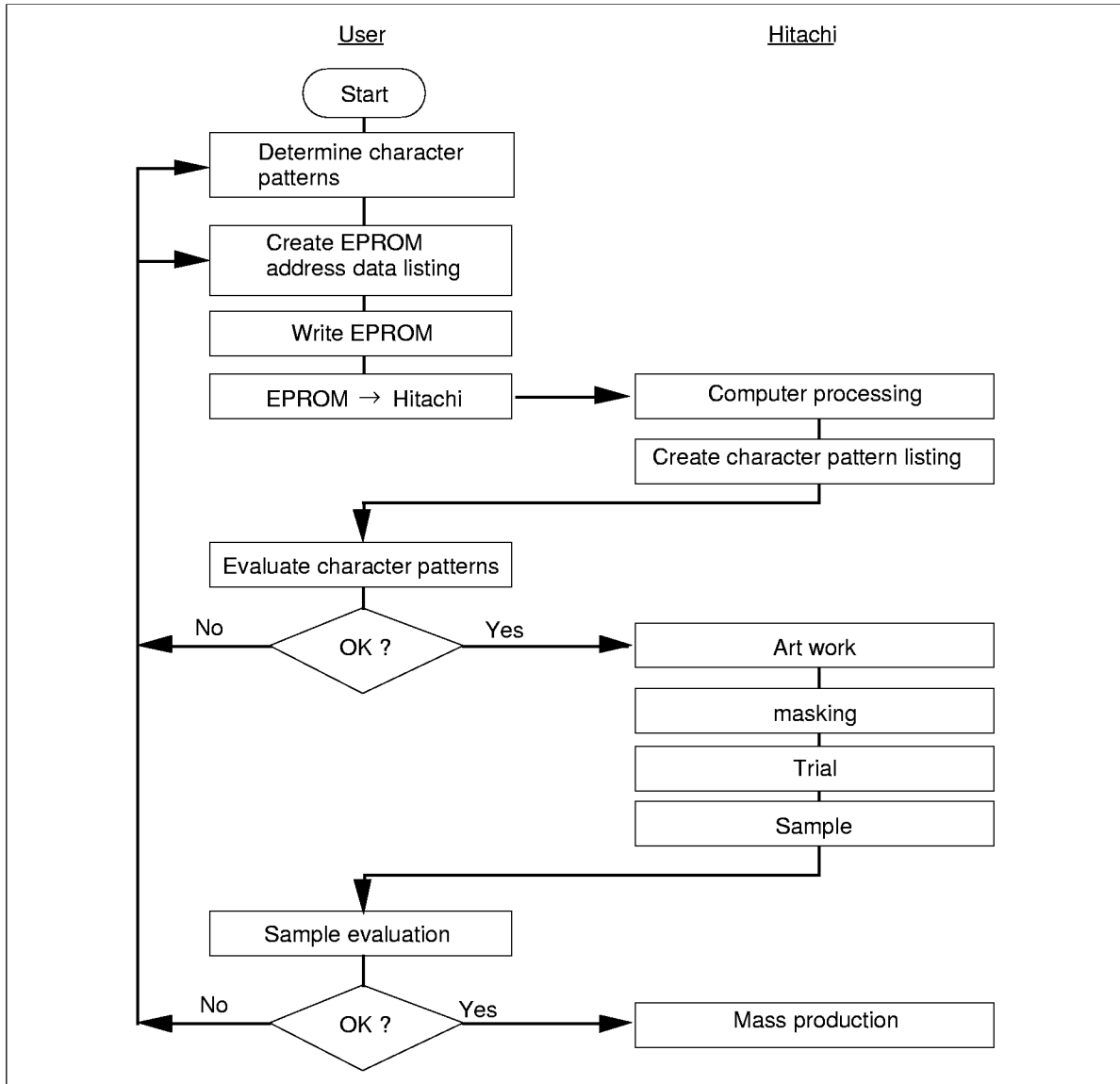

Figure 4 Character Pattern Development Procedure

The following operations correspond to the numbers listed in Figure 4:

1. Determine the correspondence between character codes and character patterns.
2. Create a listing indicating the correspondence between EPROM addresses and data.
3. Program the character patterns into an EPROM.
4. Send the EPROM to Hitachi.
5. Computer processing of the EPROM is performed at Hitachi to create a character pattern listing, which is sent to the user.
6. If there are no problems within the character pattern listing, a trial LSI is created at Hitachi and samples are sent to the user for evaluation. When it is confirmed by the user that the character patterns are correctly written, mass production of the LSI will proceed at Hitachi.

HD66727

Programming Character Patterns

This section explains the correspondence between addresses and data used to program character patterns in EPROM.

Programming to EPROM: The HD66727 character generator ROM can generate 240 6×8 -dot character patterns. Table 14 shows correspondence between the EPROM address, data, and the character pattern.

Table 14 Example of Correspondence between EPROM Address, Data, and Character Pattern (6×8 Dots)

EPROM Address											Data						
A11	A10	A9	A8	A7	A6	A5	A4	A3	A2	A1	A0	MSB	Data				LSB
											O5	O4	O3	O2	O1	O0	
0	1	0	1	1	0	0	1	0	0	0	0	0	1	0	0	0	1
								0	0	0	1	0	1	0	0	0	1
								0	0	1	0	0	1	0	0	0	1
								0	0	1	1	0	0	1	0	1	0
								0	1	0	0	0	0	0	1	0	0
								0	1	0	1	0	0	0	1	0	0
								0	1	1	0	0	0	0	1	0	0
								0	1	1	1	0	0	0	0	0	0

Character code
0
Line position

- Notes:
1. EPROM address bits A11 to A4 correspond to a character code.
 2. EPROM address bits A2 to A0 specify the line position of the character pattern. EPROM address bit A3 must be set to 0.
 3. EPROM data bits O5 to O0 correspond to character pattern data.
 4. Areas which are lit (indicated by shading) are stored as 1, and unlit areas as 0.
 5. The eighth raster-row is also stored in the CGROM, and must also be programmed. If the eighth raster-row is used for a cursor, this data must all be set to zero.
 6. EPROM data bits O7 to O6 are invalid. 0 must be written in all bits.

Handling Unused Character Patterns:

1. EPROM data outside the character pattern area: This is ignored by character generator ROM for display operation so any data is acceptable.
2. EPROM data in CGRAM area: Always fill with zeros.
3. Treatment of unused user patterns in the HD66727 EPROM: According to the user application, these are handled in either of two ways:
 - a. When unused character patterns are not programmed: If an unused character code is written into DDRAM, all its dots are lit, because the EPROM is filled with 1s after it is erased.
 - b. When unused character patterns are programmed as 0s: Nothing is displayed even if unused character codes are written into DDRAM. (This is equivalent to a space.)

Instructions

Outline

Only the instruction register (IR) and the data register (DR) of the HD66727 can be controlled by the MPU. Before starting internal operation of the HD66727, control information is temporarily stored in these registers to allow interfacing with various peripheral control devices or MPUs which operate at different speeds. The internal operation of the HD66727 is determined by signals sent from the MPU. These signals, which include register selection bit (RS), read/write bit (R/W), and the data bus (DB0 to DB7), make up the HD66727 instructions. There are four categories of instructions that:

- Control display
- Control key scan
- Control power management
- Set internal RAM addresses
- Perform data transfer with internal RAM

Normally, instructions that perform data transfer with internal RAM are used the most. However, auto-incrementation by 1 (or auto-decrementation by 1) of internal HD66727 RAM addresses after each data write can lighten the program load of the MPU.

While an instruction is being executed for internal operation, or during reset, no instruction other than the busy flag/key scan read instruction can be executed.

Because the busy flag is set to 1 while an instruction is being executed, check it to make sure it is 0 before sending another instruction from the MPU. If an instruction is sent without checking the busy flag, the time between the first instruction issue and next instruction issue must be longer than the instruction execution time itself. Refer to Table 23 for the list of each instruction execution cycles (clock pulses). The execution time depends on the operating clock frequency (oscillation frequency).

Instruction Description

Busy Flag/Key Scan Read

The busy flag/key scan read instruction (Figure 5) reads scan data SD3 to SD0 latched into scan registers SCAN0 to SCAN7, scan cycle state SF1 and SF0, and transfer flag TF, sequentially. It also reads the busy flag (BF) indicating that the system is now internally operating on a previously received instruction. If BF is 1, the internal operation is in progress. The next instruction will not be accepted until BF is cleared to 0. Adjust the data transfer rate so that the last bit of the next instruction is received after BF is cleared to 0.

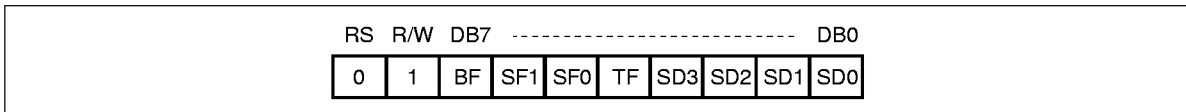

Figure 5 Busy Flag/Key Scan Read Instruction

Clear Display

The clear display instruction (Figure 6) writes space code 20H (character pattern for character code 20H must be a blank pattern) into all DDRAM addresses. It then sets DDRAM address 0 into the address counter. It also sets I/D to 1 (increment mode) in the entry mode set instruction.

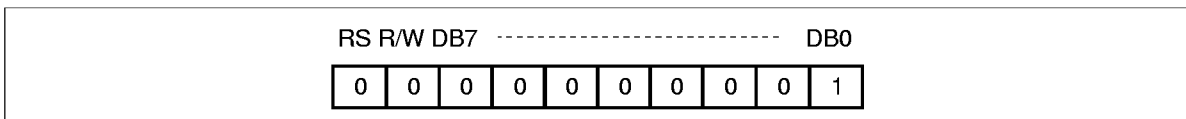

Figure 6 Clear Display Instruction

Return Home

The return home instruction (Figure 7) sets DDRAM address 0 into the address counter. The DDRAM contents do not change. The cursor or blinking goes to the top left of the display.

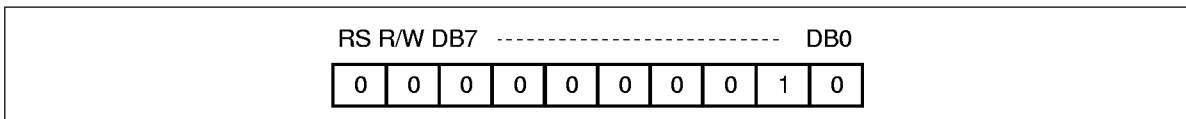

Figure 7 Return Home Instruction

Start Oscillator

The start oscillator instruction (Figure 8) re-starts the oscillator from a halt state in the standby mode. After issuing this instruction, wait at least 10 ms for oscillation to become stable before issuing the next instruction. (Refer to the Standby Mode section.)

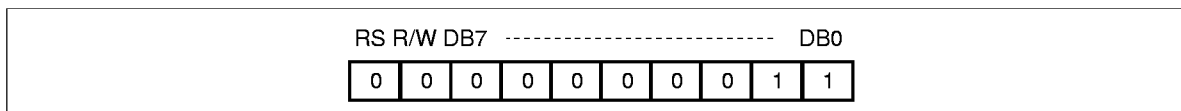

Figure 8 Start Oscillator Instruction

Entry Mode Set

The entry mode set instruction (Figure 9) includes the I/D and OSC bits.

I/D: Increments (I/D = 1) or decrements (I/D = 0) the DDRAM address by 1 when a character code is written into or read from DDRAM. The cursor or blinking moves to the right when incremented by 1 and to the left when decremented by 1. The same applies to writing and reading of CGRAM and SEGRAM.

OSC: Divides the external clock frequency by four (OSC = 1) and uses the resulting clock as an operating clock for all internal operations. The execution time for this instruction and subsequent ones is therefore quadrupled. The execution time of clearing this bit (OSC = 0) is also quadrupled. Note that, the key scan cycle is affected. For details, refer to the Partial-Display-Off Function section.

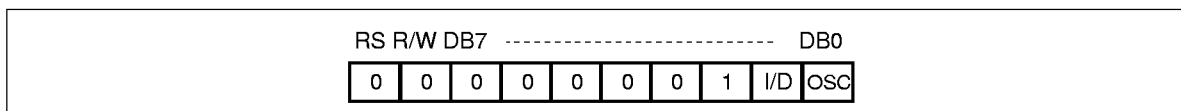

Figure 9 Entry Mode Set Instruction

Cursor Control

The cursor control instruction (Figure 10) includes the B/W, C, and B bits.

B/W: When B/W is 1, the character at the cursor position is cyclically (every 32 frames) displayed with black-white inversion.

C: The cursor is displayed on the 8th raster-row when C is 1. The cursor is displayed using 5 dots in the 8th raster-row for 5 × 8-dot character font, or 6 dots in the 8th raster-row for 6 × 8 dot character font.

B: The character indicated by the cursor blinks when B is 1. The blinking is displayed as switching between all black dots and displayed characters every 32 frames. The cursor and blinking can be set to display simultaneously. When LC and B = 1, the blinking is displayed as switching between all white dots and displayed characters.

Figure 11 shows cursor control examples.

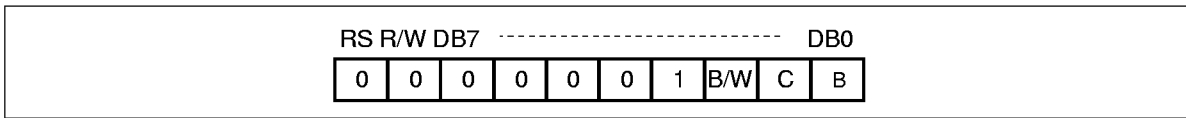

Figure 10 Cursor Control Instruction

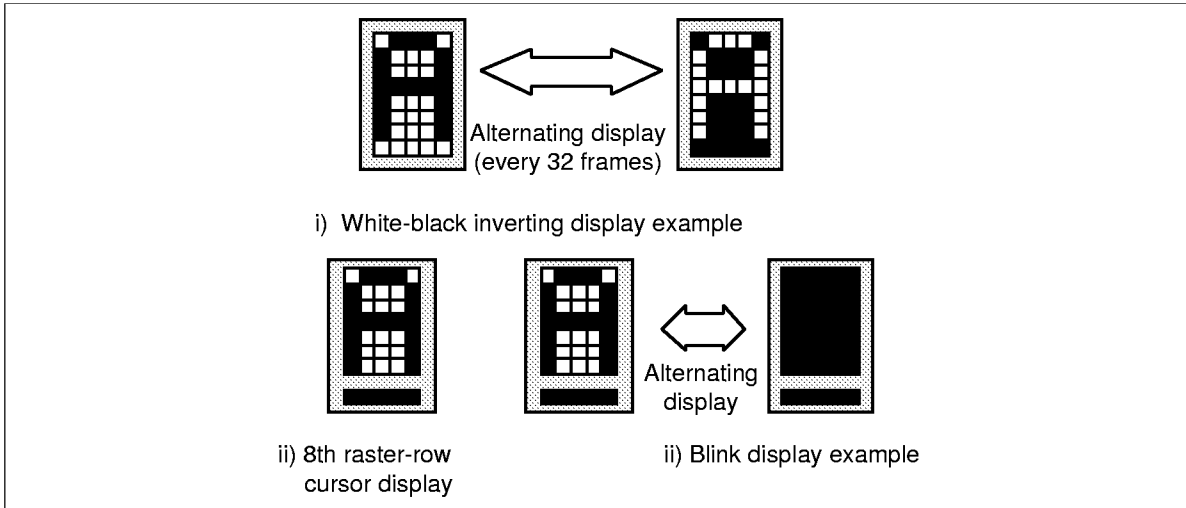

Figure 11 Cursor Control Examples

Display On/Off Control

The display on/off control instruction (Figure 12) includes the D, FW, and LC bits.

D: The character display and the segment display for multiplexing icon are on when D is 1. When off, the display data remains in DDRAM or SEGRAM, and can be displayed instantly by setting D to 1. When D is 0, multiplexing LCD drive halts and the display is off with the SEG1 to SEG60 outputs, COM1 to COM32 outputs, and COMS1/2 output set to V_{CC} level and off. Because of this, the HD66727 can control charging current for the LCD with driving.

FW: When FW = 0, the font width is 5 dots. When FW = 1, the font width is 6 dots.

LC: When LC = 1, a cursor attribute is assigned to the line that contains the address counter (AC) value. Cursor mode can be selected with the B/W, C, and B bits. Refer to the Line-Cursor Display section.

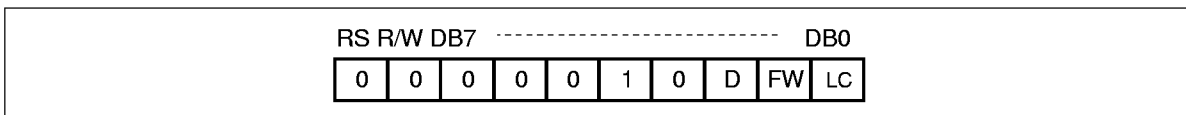

Figure 12 Display On/Off Control Instruction

Power Control

The power control instruction (Figure 13) includes the AMP, SLP, and STB bits.

AMP: When AMP = 1, each voltage follower for V1 to V5 pins and the booster are turned on. When AMP = 0, current consumption can be reduced while character or segment display controlled by the multiplexing drive method is not being used.

SLP: When SLP = 1, the HD66727 enters the sleep mode, where all the internal operations are halted except for the annunciator display function, key scan function, and the R-C oscillator, thus reducing current consumption. For details, refer to the Sleep Mode section. Only the following instructions can be executed during the sleep mode.

1. Annunciator address (AAN) set
2. Annunciator data write
3. LED drive/general output port data write
4. Annunciator display on or off (DA = 1 or 0)
5. Voltage follower on or off (AMP = 1 or 0)
6. Standby mode set (STB = 1)
7. Sleep mode cancel (SLP = 0)
8. Key scan data (SD) read
9. Key scan interrupt generation enable/disable (IRE = 1 or 0)
10. Key scan cycle (KF) set

During the sleep mode, the other RAM data and instructions cannot be updated but they are retained.

STB: When STB = 1, the HD66727 enters the standby mode, where the device completely stops, halting all the internal operations including the internal R-C oscillator and no external clock pulses are supplied. However, annunciator display alone is available when the alternating signal for annunciator-driving signals is supplied to the EXM pin. When the annunciator display is not needed, make sure to turn off display (DA = 0). Normal key scanning is also halted in the standby mode. However, the HD66727 can detect four key inputs connected with strobe signal KST0, thus generating the key scan interrupt (IRQ*). For details, refer to the Standby Mode section and the Key Scan Interrupt section. Only the following instructions can be executed during the standby mode.

1. Annunciator address (AAN) set
2. Annunciator data write
3. LED drive/general output port data write
4. Annunciator display on or off (DA = 1 or 0)
5. Voltage follower on or off (AMP = 1 or 0)
6. Start oscillator
7. Standby mode cancel (STB = 0)
8. Key scan interrupt generation enable/disable (IRE = 1 or 0)

HD66727

During the standby mode, the other RAM data and instructions may be lost; they must be set again after the standby mode is canceled.

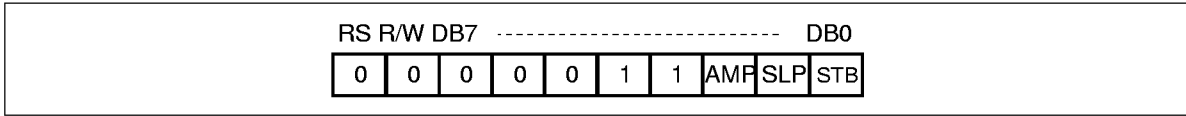

Figure 13 Power Control Instruction

Display Control

The display control instruction (Figure 14) includes the NL and DL bits.

NL1, NL0: Designates the number of display lines. This value determines the LCD drive multiplexing duty ratio (Table 15). The address assignment is the same for all display line modes.

DL3–DL1: Doubles the height of characters on a specified line. The first, second, or third line is doubled in height when DL1, DL2, or DL3 = 1, respectively. Two lines can be simultaneously doubled in a 4-line display. Refer to the Double-Height Display section.

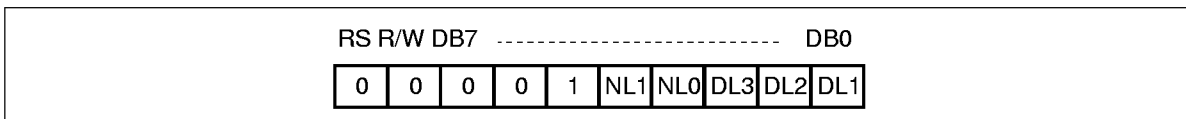

Figure 14 Display Control Instruction

Table 15 NL Bits and Display Lines

NL1	NL0	Number of Display Lines	LCD Drive Multiplexing Duty Ratio
0	0	1	1/10
0	1	2	1/18
1	0	3	1/26
1	1	4	1/34

Contrast Control

The contrast control instruction (Figure 15) includes the SN and CT bits.

SN2: Combined with the SN1 and SN0 bits described in the Scroll Control section to select the top line to be scrolled (display-start line).

CT3–CT0: Controls the LCD drive voltage (potential difference between V_{CC} and V5) to adjust contrast (Figure 16 and Table 16). For details, refer to the Contrast Adjuster section.

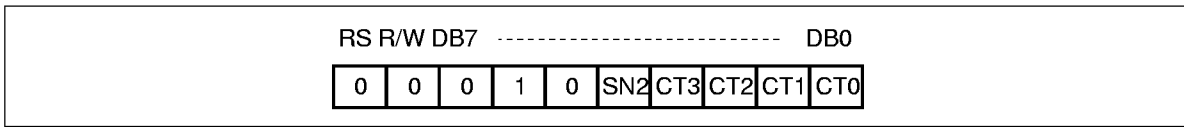

Figure 15 Contrast Control Instruction

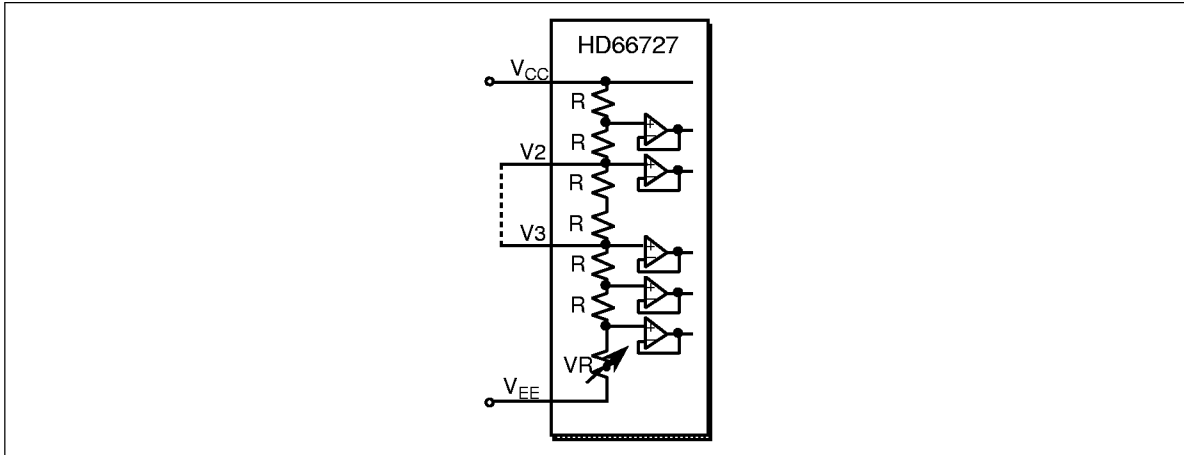

Figure 16 Contrast Adjuster

Table 16 CT Bits and Variable Resistor Value of Contrast Adjuster

CT3	CT2	CT1	CT0	Variable Resistor Value (VR)
0	0	0	0	6.4 x R
0	0	0	1	6.0 x R
0	0	1	0	5.6 x R
0	0	1	1	5.2 x R
0	1	0	0	4.8 x R
0	1	0	1	4.4 x R
0	1	1	0	4.0 x R
0	1	1	1	3.6 x R
1	0	0	0	3.2 x R
1	0	0	1	2.8 x R
1	0	1	0	2.4 x R
1	0	1	1	2.0 x R
1	1	0	0	1.6 x R
1	1	0	1	1.2 x R
1	1	1	0	0.8 x R
1	1	1	1	0.4 x R

HD66727

Scroll Control

The scroll control instruction (Figure 17) includes the SN and SL bits.

SN1, SN0: Combined with the SN2 bit described in the Contrast Control section to select the top line to be displayed (display-start line) through the data output from the COM1 pin (Table 17). After first five lines are displayed from the top line, the cycle is repeated and scrolling continues.

SL2–SL0: Selects the top raster-row to be displayed (display-start raster-row) in the display-start line specified by SN2 to SN0. Any raster-row from the first to eighth can be selected (Table 18). This function is used to perform vertical smooth scroll together with SN2 to SN0. For details, refer to the Vertical Smooth Scroll section.

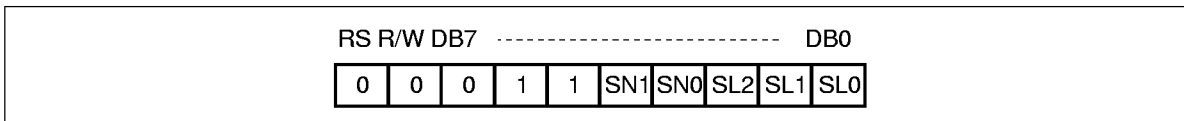

Figure 17 Scroll Control Instruction

Table 17 SN Bits and Display-Start Lines

SN2	SN1	SN0	Display-Start Line
0	0	0	1st line
0	0	1	2nd line
0	1	0	3rd line
0	1	1	4th line
1	0/1	0/1	5th line

Table 18 SN Bits and Display-Start Raster-Rows

SL2	SL1	SL0	Display-Start Raster-Row
0	0	0	1st raster-row
0	0	1	2nd raster-row
0	1	0	3rd raster-row
0	1	1	4th raster-row
1	0	0	5th raster-row
1	0	1	6th raster-row
1	1	0	7th raster-row
1	1	1	8th raster-row

Annunciator/SEGRAM Address Set

The annunciator/SEGRAM address set instruction (Figure 18) includes the DA and A (AAN/ASEG) bits.

DA: Turns annunciator display on or off. When DA = 1, annunciator display is turned on and driven statically. When DA = 0, annunciator display is turned off with ASEG1 to ASEG10 and ACOM pins held to V_{CC} level.

The internal operating clock supply is halted during the standby mode; make sure to turn off display (DA = 0) if the external alternating signal is not supplied. For details, refer to the Segment Display and Annunciator Display section and the Standby Mode section.

AAAA: Used for setting the SEGRAM address into the address counter (AC) or for directly setting the annunciator address. The SEGRAM addresses range from 1000H to 1111H (8 addresses), while the annunciator addresses range from 0000H to 0010H (3 addresses).

The annunciator address is directly set without using the address counter, and consequently must be updated for each access. The annunciator address can be set even during the sleep and standby modes.

Once the SEGRAM address is set, data in the SEGRAM can be accessed consecutively since the address counter is automatically incremented or decremented by one according to the I/D bit setting after each access. The SEGRAM address cannot be set during the sleep or standby mode.

AAAA is the address for setting the 0011 LED/general port data; 0100 is the address for setting the SEG/COM shift direction. See 'Annunciator Driver Circuit' for details.

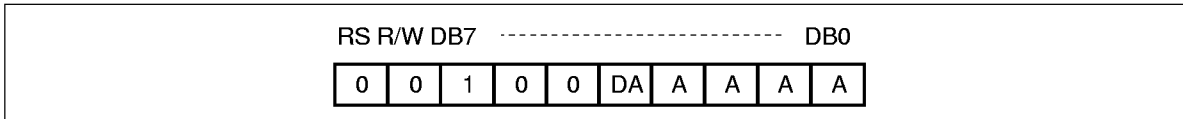

Figure 18 Annunciator/SEGRAM Address Set Instruction

HD66727

Table 19 Annunciator/LED/SEG/COM Shift Direction/SEGRAM Address Set

Address	A	A	A	A	DB7	DB6	DB5	DB4	DB3	DB2	DB1	DB0
Annunciator address	0	0	0	0	ASEG1		ASEG2		ASEG3		ASEG4	
	0	0	0	1	ASEG5		ASEG6		ASEG7		ASEG8	
	0	0	1	0	ASEG9		ASEG10		ASEG11		ASEG12	
LED port address	0	0	1	1	*	*	PORT2	PORT1	PORT0	LED2	LED1	LED0
SEG/COM shift direction address	0	1	0	0	*	*	*	*	*	*	CMS	SGS
SEGRAM address	1	0	0	0	*	*	SEGRAM data in COMS1 side					
	1	0	0	1	*	*						
	1	0	1	0	*	*						
	1	0	1	1	*	*						
	1	1	0	0	*	*	SEGRAM data in COMS2 side					
	1	1	0	1	*	*						
	1	1	1	0	*	*						
	1	1	1	1	*	*						

CGRAM Address Set

The CGRAM address set instruction (Figure 19) includes the A (ACG) bits.

AAAAA: Used for setting the CGRAM address into the address counter (AC). The CGRAM addresses range from 00H to 1FH (32 addresses) (Table 19).

Once the CGRAM address is set, data in the CGRAM can be accessed consecutively since the address counter is automatically incremented or decremented according to the I/D bit setting after each access. The CGRAM address cannot be set during the sleep or standby mode.

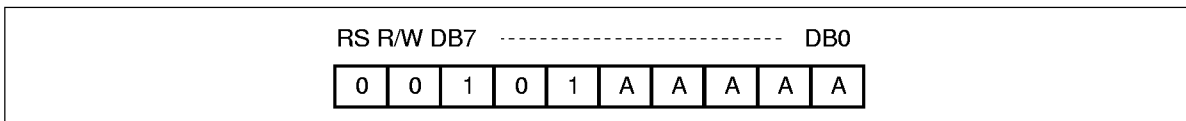

Figure 19 CGRAM Address Set Instruction

Table 20 CGRAM Addresses and Character Codes

Displayed Character	CGRAM Address	Character Codes
1st character	"00"H to "07"H	"00"H
2nd character	"08"H to "0F"H	"01"H
3rd character	"10"H to "17"H	"02"H
4th character	"18"H to "1F"H	"03"H

DDRAM Address Set

The DDRAM address set instruction (Figure 20) includes the A (ADD), IRE, and KF bits.

AAAAAA: Used for setting the DDRAM address into the address counter (AC). The DDRAM addresses range from "00"H to "4B"H (60 addresses) (Table 21).

Once the DDRAM address is set, data in the DDRAM can be accessed consecutively since the address counter is automatically incremented or decremented according to the I/D bit setting after each access. Here, invalid addresses are automatically skipped. The DDRAM address cannot be set during the sleep or standby mode.

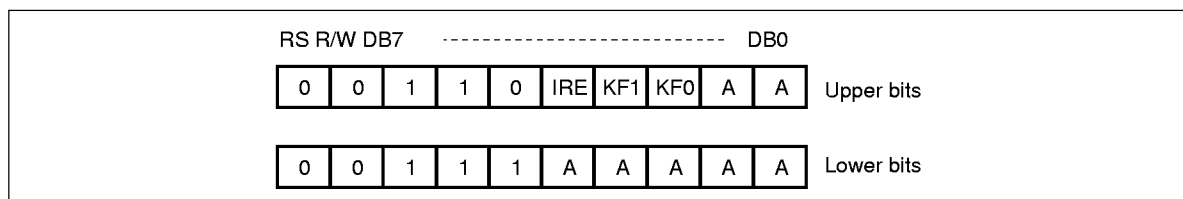

Figure 20 DDRAM Address Set Instruction

Table 21 DDRAM Addresses and Invalid Addresses

Displayed Line	DDRAM Address	Invalid Addresses
1st line	"00"H to "0B"H	"0C"H to "0F"H
2nd line	"10"H to "1B"H	"1C"H to "1F"H
3rd line	"20"H to "2B"H	"2C"H to "2F"H
4th line	"30"H to "3B"H	"3C"H to "3F"H
5th line	"40"H to "4B"H	"4C"H and subsequent addresses

HD66727

IRE: When IRE is 1, the key scan interrupt (IRQ*) generation is enabled. When a key is pressed, the IRQ* pin outputs a low level signal.

KF1, KF0: Used for specifying the key scan cycle. Set these bits according to the mechanical characteristics of the keys and the oscillation frequency (Table 22).

Table 22 KF Bits and Key Scan Cycles

NL1	KF1	KF0	Key Scan Cycle	Key Strobe Width
1 or 2 display lines (NL1=0)	0	0	160/fosc	20/fosc
1 or 2 display lines (NL1=0)	0	1	320/fosc	40/fosc
1 or 2 display lines (NL1=0)	1	0	640/fosc	80/fosc
1 or 2 display lines (NL1=0)	1	1	1,280/fosc	160/fosc
3 or 4 display lines (NL1=1)	0	0	320/fosc	40/fosc
3 or 4 display lines (NL1=1)	0	1	640/fosc	80/fosc
3 or 4 display lines (NL1=1)	1	0	1,280/fosc	160/fosc
3 or 4 display lines (NL1=1)	1	1	2,560/fosc	320/fosc

Note: fosc is the oscillation frequency or external clock frequency.

Write Data to RAM

The write data to RAM instruction (Figure 21) writes 8-bit data to annunciator or DDRAM, lower 6-bit data to LED port, SEGRAM or CGRAM, or lower two bits to shift direction change bits of SEG/COM that is selected by the previous specification of the address set instruction (annunciator/LED/SEGRAM address set, CGRAM address set, or DDRAM address set).

After a write, the address is automatically incremented or decremented by 1 according to the I/D bit setting in the entry mode set instruction. The annunciator or LED port address is not automatically updated; it must be specifically updated to write data to a different address. During the sleep and standby modes, DDRAM, CGRAM, or SEGRAM cannot be accessed.

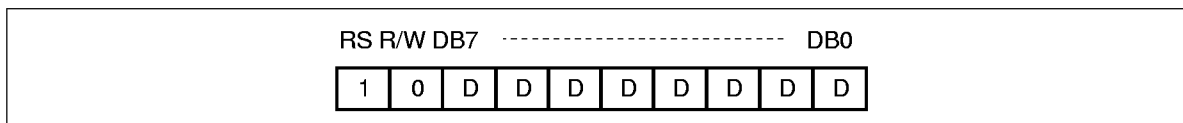

Figure 21 Write Data to RAM Instruction

Read Data from RAM

The read data from RAM instruction (Figure 22), reads 8-bit data from DDRAM, or 5-bit data from CGRAM or SEGRAM that is selected by the previous specification of the address set instruction (SEGRAM address set, CGRAM address set, or DDRAM address set). The unused upper three bits of CGRAM or SEGRAM data are read as 000; annunciator data cannot be read. If no address is specified by the address set instruction just before this instruction, the first data read will be invalid. When executing consecutive read instructions, the next data is normally read from the next address.

After a read, the address is automatically incremented or decremented by 1 according to the I/D bit setting in the entry mode set instruction.

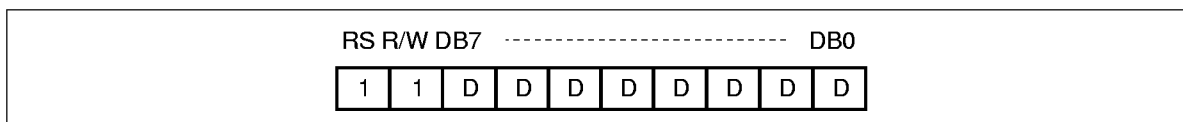

Figure 22 Read Data from RAM Instruction

HD66727

Table 23 Instruction List

No.	Instruction	Code										Description	Execution Cycle *1	
		R/W	RS	DB7	DB6	DB5	DB4	DB3	DB2	DB1	DB0			
KS	Busy flag/key scan read	1	0	BF	SF	TF			SD				Reads busy flag (BF), key-scan state (SF and TF), and data in key scan registers (SD).	0
CL	Clear display	0	0	0	0	0	0	0	0	0	0	1	Clears entire display and sets address 0 into the address counter.	310
CH	Return home	0	0	0	0	0	0	0	0	0	1	0	Sets DDRAM address 0 into the address counter.	5
OS	Start oscillator	0	0	0	0	0	0	0	0	0	1	1	Starts the oscillation standby mode.	—
EM	Entry mode set	0	0	0	0	0	0	0	1	I/D	OSC		Sets the address update direction after RAM access (I/D), and system clock division (OSC).	5
CR	Cursor control	0	0	0	0	0	0	1	B/W	C	B		Sets black-white inverting cursor (B/W), 8th raster-row cursor (C), and blink cursor (B).	5
DO	Display on/off control	0	0	0	0	0	1	0	D	FW	LC		Sets character/segment display on (D), font width (FW), and line-cursor display (LC).	5
PW	Power control	0	0	0	0	0	1	1	AMP	SLP	STB		Turns on LCD power supply (AMP), and sets the sleep mode (SLP) and standby mode (STB).	5
DC	Display control	0	0	0	0	1	NL1	NL0	DL3	DL2	DL1		Sets the number of display lines (NL) and the lines to be doubled in height.	5
CN	Contrast control	0	0	0	1	0	SN2				CT		Sets the display-start line (SN2) and contrast-adjusting value (CT).	5
SC	Scroll control	0	0	0	1	1	SN1	SN0			SL		Sets the display-start line (SN) and display-start raster-row (SL).	5
AS	Annunciator/SEGRAM address set	0	0	1	0	0	DA				AAN/ASEG		Turns on the annunciator display (DA) and sets annunciator/SEGRAM address.	5
CA	CGRAM address set	0	0	1	0	1					ACG		Sets the initial CGRAM address to the address counter.	5

Table 23 Instruction List (cont)

No.	Instruction	Code										Description	Execution Cycle ¹
		R/W	RS	DB7	DB6	DB5	DB4	DB3	DB2	DB1	DB0		
DA	DDRAM address set (upper bits)	0	0	1	1	0	IRE	KF1	KF0	ADD (upper bits)		Sets the initial higher DDRAM address to the address counter, and key scan cycle.	5
DA	DDRAM address set (lower bits)	0	0	1	1	1				ADD (lower bits)		Sets the initial lower DDRAM address to the address counter.	5
WD	Write data to RAM	0	1							Write data		Writes data to DDRAM, CGRAM, SEGRAM, annunciator/LED/general port, or SEG/COM shift direction.	5
RD	Read data from RAM	1	1							Read data		Reads data from DDRAM, CGRAM, or SEGRAM.	5

Note: 1. Represented by the number of operating clock pulses; the execution time depends on the supplied clock frequency or the internal oscillation frequency.

Bit definition:

- BF = 1: Internally operating
- SF: Key-scan state
- TF = 1: Key-scan internally operating
- SD: Key-scanned data
- I/D = 1: Address increment
- I/D = 0: Address decrement
- OSC = 1: System clock divided by four
- B/W = 1: Black-white inverting cursor on
- C = 1: 8th raster-row cursor on
- B = 1: Blink cursor on
- D = 1: Character/segment display on
- FW = 0: 5-dot font width
- FW = 1: 6-dot font width
- LC = 1: Line containing AC given cursor attribute
- AMP = 1: Voltage followers and booster on
- SLP = 1: Sleep mode
- STB = 1: Standby mode
- CT: Contrast adjustment
- NL1, NL0: Number of display lines [00: 1 line (1/10 duty ratio), 01: 2 lines (1/18 duty ratio), 10: 3 lines (1/26 duty ratio), 11: 4 lines (1/34 duty ratio)]
- DL3–DL1: Double-height lines (DL1 = 1: 1st line, DL2 = 1: 2nd line, DL3 = 1: 3rd line)
- SN2–SN0: Display-start line (000: 1st line, 001: 2nd line, 010: 3rd line, 011: 4th line, 100: 5th line)
- SL2–SL0: Display-start raster-row (000: 1st raster-row ... 111: 8th raster-row)
- DA = 1: Annunciator display on
- AAN/ASEG: Annunciator address (0000–0010), LED/general port address (PORT2–PORT0, LED2–LED0) (0011)
- AAN/ASEG: SEG/COM shift change address (CMS, SGS) (0100), SEGRAM address (1000–1111)

HD66727

ACG: CGRAM address (00000–11111)
ADD: DDRAM address (0000000–1001011)
IRE = 1: Key scan interrupt generation enabled
KF1, KF0: Key scan cycle set

Reset Function

Initialization by Internal Reset Circuit

The HD66727 is internally initialized by RESET* input. During initialization, the system executes the instructions as described below. Here, the busy flag (BF) therefore indicates a busy state (BF = 1), accepting no instruction or RAM data access from the MPU. Here, reset input must be held at least 10 ms.

After releasing power-on reset, clear display instruction is operated. So wait for 1,000 clock-cycles or more.

Make sure to reset the HD66727 immediately after power-on.

Initialization of Instruction Sets, RAM, and Pins

Instruction set initialization:

1. Clear display executed
Writes 20H to DDRAM after releasing reset.
2. Return home executed
Sets the address counter (AC) to 00H to select DDRAM
3. Start oscillator executed
4. Entry mode set
I/D = 1: Increment by 1
OSC = 0: Clock frequency not divided
5. Cursor control
B/W = 0: White-black inverting cursor off
C = 0: 8th raster-row cursor off
B = 0: Blink cursor off
6. Display on/off control
D = 0: Character/segment display off
FW = 0: 5-dot font width
LC = 0: Line-cursor off
7. Power control
AMP = 0: LCD power supply off
SLP = 0: Sleep mode off
STB = 0: Standby mode off

8. Display control
 - NL1, NL0 = 11: 4-line display (1/34 multiplexing duty ratio)
 - DL3–DL1 = 000: Double-height display off
9. Contrast adjust
 - CT = 0000: Weak contrast
10. Scroll control
 - SN2–SN0 = 000: First line displayed at the top
 - SL2–SL0 = 000: First raster-row displayed at the top of the first line
11. Annunciator control
 - DA = 0: Annunciator display off
12. Key scan control
 - IRE = 0: Key scan interrupt (IRQ*) generation disabled
 - KF1, KF0 = 00: Key scan cycle set to 320 clock cycles
13. LED/general port
 - LED2/LED1/LED0 = 000: LED2/LED1/LED0 outputs = V_{CC} level
 - PORT2/ PORT1/ PORT0 = 000: PORT2/ PORT1/ PORT0 outputs = GND level
14. LCD driver output direction
 - CMS = 0: Starts shift from COM1/32
 - SGS = 0: Starts shift from SEG1/60

RAM data initialization:

1. DDRAM
 - All addresses are initialized to 20H by the clear display instruction
2. CGRAM/SEGRAM
 - Not automatically initialized by reset input; must be initialized by software while display is off (D = 0)
3. Annunciator data
 - Not automatically initialized by reset input; must be initialized by software while display is off (DA = 0)

Output pin initialization:

1. LCD driver output pins (SEG/COM, ASEG/ACOM): Outputs V_{CC} level
2. Booster output pins (V5OUT2 and V5OUT3): Outputs GND level
3. Oscillator output pin (OSC2): Outputs oscillation signal
4. Key strobe pins (KST0 to KST7): Outputs strobe signals at a specified time interval
5. Key scan interrupt pin (IRQ*): Outputs V_{CC} level
6. LED driving port (LED0–LED2): Outputs V_{CC} level
7. General output port (PORT0–PORT2): Outputs GND level

Serial Data Transfer

I²C Bus Interface

Grounding the IM pin (interface mode pin) allows serial data transfer conforming to the I²C bus interface using the serial data line (SDA) and serial transfer clock line (SCL). Here, the HD66727 operates in an transmit/receive slave mode.

The HD66727 initiates serial data transfer by transferring the first byte when a high SCL level at the falling edge of the SDA input is sampled; it ends serial data transfer when a high SCL level at the rising edge of the SDA input is sampled.

Table 24 illustrates the first bytes of I²C bus interface data and Figure 23 shows the I²C bus interface timing sequence.

The HD66727 is selected when the higher six bits of the 7-bit slave address in the first byte transferred from the master device match the 6-bit device identification code assigned to the HD66727. The HD66727, when selected, receives the subsequent data string. The lower bits of the identification code can be determined by the ID1 and ID0 pins; select an appropriate code that is not assigned to any other slave device. The upper four bits is fixed to 0111. Two different slave addresses must be assigned to a single HD66727 because the least significant bit (LSB) of the slave address is used as a register select bit (RS): when RS = 0, an instruction can be issued or key scan data can be read, and when RS = 1, data can be written to or read from RAM. Read or write is selected according to the eighth bit of the first byte (R/W bit) as shown in Table 25.

The ninth bit of the first byte is a receive-data acknowledge bit (ACK). When the received slave address matches the device ID code, the HD66727 pulls down the ACK bit to a low level. Therefore, the ACK output buffer is an open-drain structure, only allowing low-level output. However, the ACK bit is undetermined immediately after power-on; make sure to initialize the LSI using the RESET* input.

After identifying the address in the first byte, the HD66727 receives the subsequent data as an HD66727 instruction or as RAM data, or transmits key scan data or RAM data. Having received or transmitted 8-bit data normally, the HD66727 pulls down the ninth bit (ACK) to a low level. Therefore, if the ACK is not returned, the data must be transferred again. Multiple bytes of data can be consecutively transferred until the transfer-end condition is satisfied. Here, when the serial data transfer rate is longer than the HD66727 instruction execution time, effective data transfer is possible without retransmission (see Table 23, Instruction List). Note that the display clear instruction alone requires longer execution time than the others.

Table 24 First Bytes of I²C Bus Interface Data

First Byte of	Transferred Bit String									
	S	Bit 1	Bit 2	Bit 3	Bit 4	Bit 5	Bit 6	Bit 7	Bit 8	Bit 9
I ² C bus system * ¹	Transfer start	A6	A5	A4	A3	A2	A1	A0	R/W	ACK
HD66727 * ²	Transfer start	0	1	1	1	ID1	ID0	RS	R/W	ACK

Notes: 1. Bits 1 to 7 of the first byte of the I²C bus system indicate the I²C slave address.
 2. Bits 1 to 6 of the first byte of the HD66727 indicate the device ID code.

Table 25 RS and R/W Bit Function of I²C Bus Interface Data

RS	R/W	Function
0	0	Writes instruction
0	1	Reads key scan data and BF flag
1	0	Writes RAM data
1	1	Reads RAM data

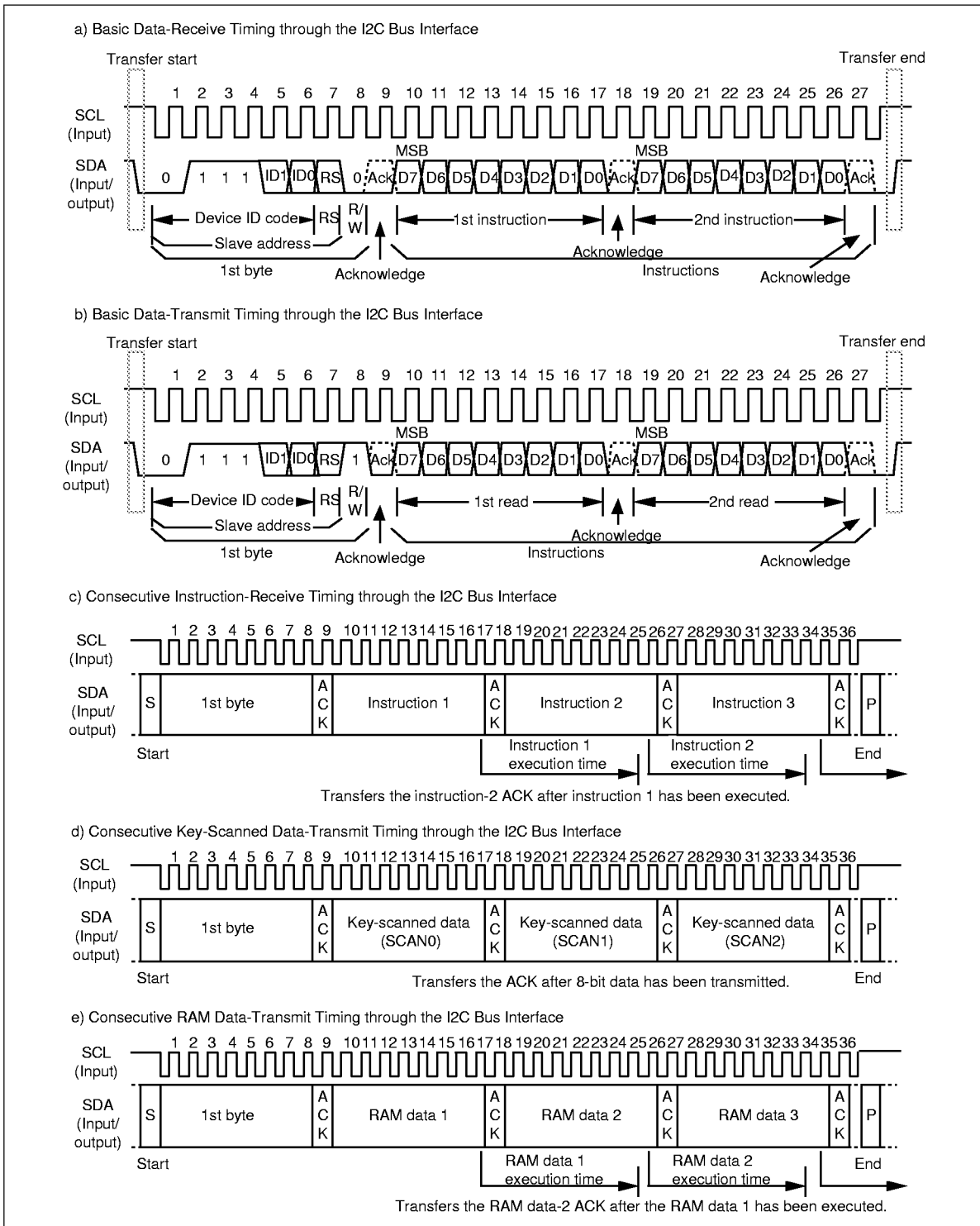

Figure 23 I²C Bus Interface Timing Sequence

Clock-Synchronized Serial Interface

Setting the IM pin (interface mode pin) to the high level allows standard clock-synchronized serial data transfer, using the chip select line (CS*), serial data line (SDA), and serial transfer clock line (SCL).

The HD66727 initiates serial data transfer by transferring the start byte at the falling edge of the CS* input. It ends serial data transfer at the rising edge of the CS* input.

Table 24 illustrates the first bytes of I²C bus interface data and Figure 24 shows the clock-synchronized serial interface timing sequence.

The HD66727 is selected when the 6-bit chip address in the start byte transferred from the transmitting device matches the 6-bit device identification code assigned to the HD66727. The HD66727, when selected, receives the subsequent data string. The least significant bit of the identification code can be determined by the ID0 pin. The upper five bits must be 01110. Two different chip addresses must be assigned to a single HD66727 because the seventh bit of the start byte is used as a register select bit (RS): when RS = 0, an instruction can be issued or key scan data can be read, and when RS = 1, data can be written to or read from RAM. Read or write is selected according to the eighth bit of the start byte (R/W bit) as shown in Table 27.

After receiving the start byte, the HD66727 receives or transmits the subsequent data byte-by-byte. Data is transferred with the MSB first. To transfer data consecutively, adjust the data transfer rate so that the HD66727 can complete the current instruction before the eighth bit of the next instruction is transferred (see Table 23, Instruction List). If the next instruction is transferred during execution of the current instruction, the next instruction will be ignored. Note that the display-clear instruction alone requires longer execution time than the others.

Table 26 Start Byte of Clock-Synchronized Serial Interface Data

S	Bit 1	Bit 2	Bit 3	Bit 4	Bit 5	Bit 6	Bit 7	Bit 8
Transfer start	0	1	1	1	0	ID0	RS	R/W

Note: Bits 1 to 6 indicate the device ID code.

Table 27 RS and R/W Bit Function of Clock-Synchronized Serial Interface Data

RS	R/W	Function
0	0	Writes instruction
0	1	Reads key scan data and BF flag
1	0	Writes RAM data
1	1	Reads RAM data

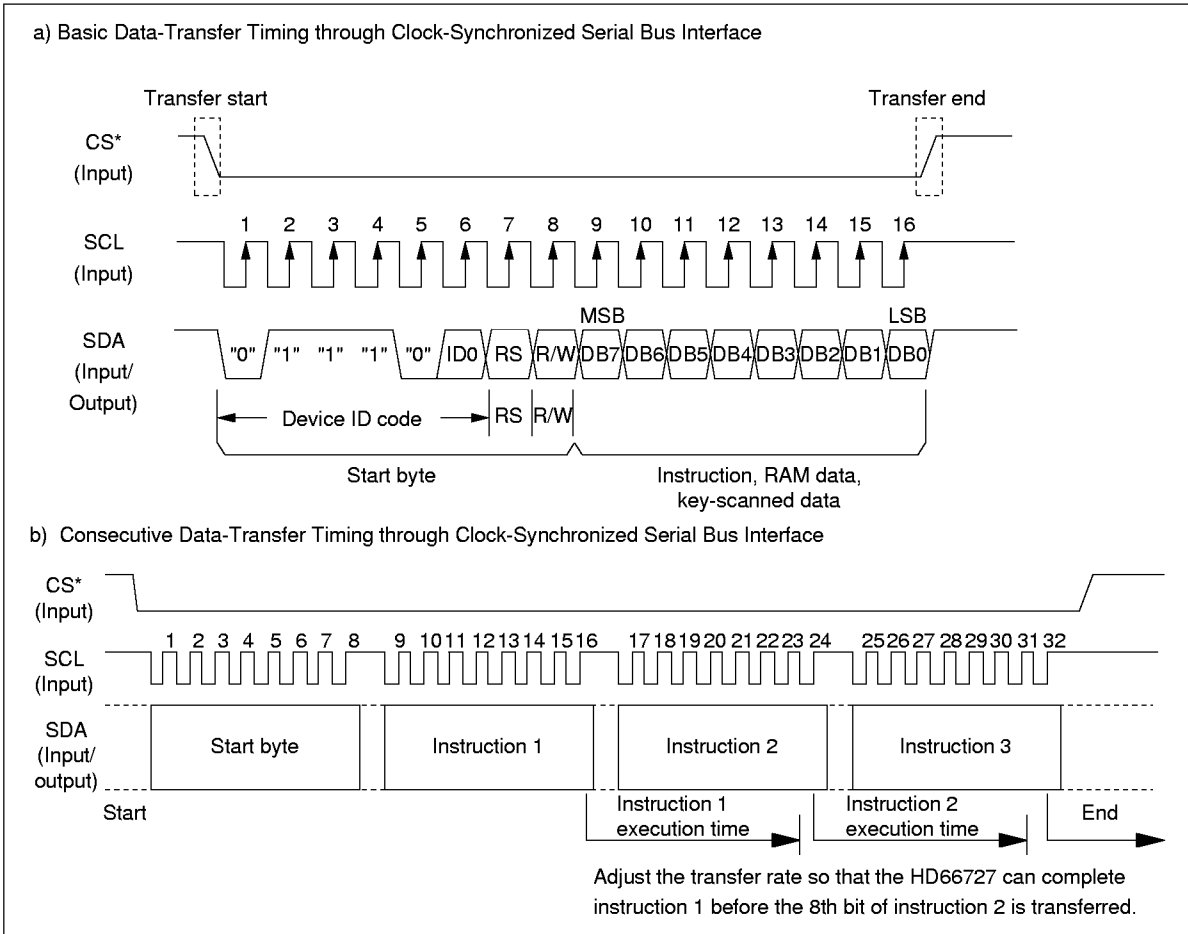

Figure 24 Clock-Synchronized Serial Interface Timing Sequence

Key Scan Control

Key Scan Mechanism

The key matrix scanner senses and holds the key states at each rising edge of the key strobe signals (KST) that are output by the HD66727. The key strobe signals are output as time-multiplexed signals from KST0 to KST7. After passing through the key matrix, these strobe signals are used to sample the key state on four inputs KIN0 to KIN3, enabling up to 32 keys to be scanned (Figure 25).

The states of inputs KIN0 to KIN3 are sampled by key strobe signal KST0 and latched into the SCAN0 register. Similarly, the data sampled by strobe signals KST1 to KST7 is latched into the SCAN1 to SCAN7 registers, respectively (Figure 26). Key pressing is stored as 1 in these registers.

The generation cycle and pulse width of the key strobe signals depend on the operating frequency (oscillation frequency) of the HD66727, the display line determined by the NL1 bit, and the key scan cycle determined by the KF0 and KF1 bits. For example, when the operating frequency is 160 kHz, NL1 is 1, and KF0 and KF1 are both 0, the generation cycle is 8.0 ms and the pulse width is 1.0 ms (Figure 27). When the operating frequency (oscillation frequency) is changed, the above generation cycle and the pulse width are also changed in inverse proportion (Table 28).

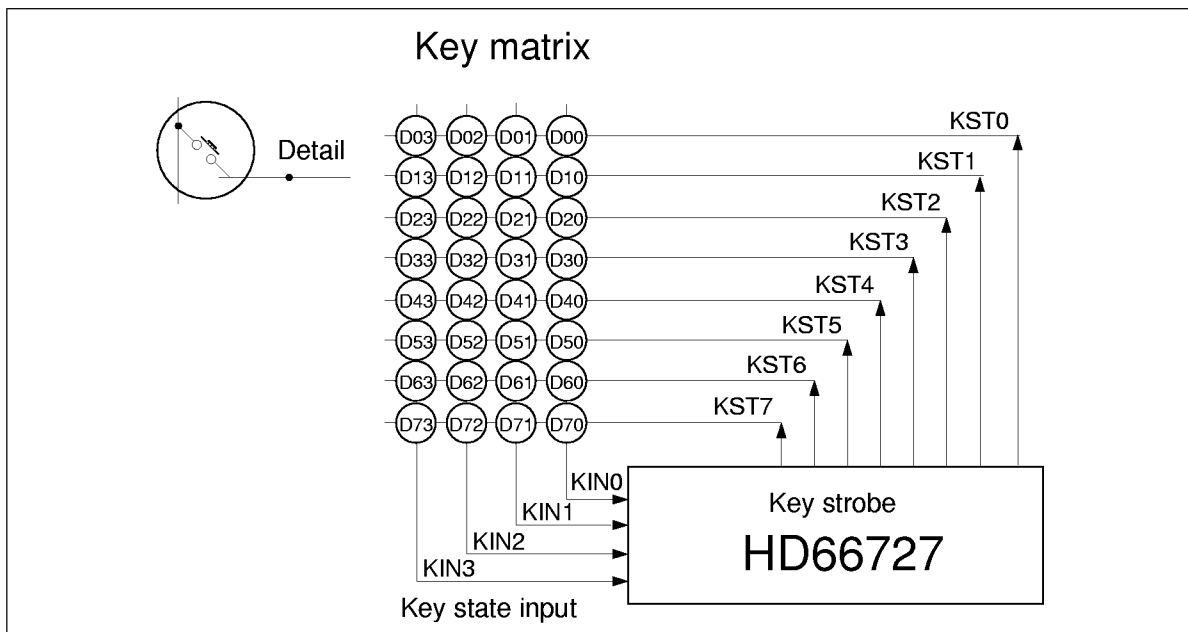

Figure 25 Key Scan Configuration

	KIN3	KIN2	KIN1	KIN0	
SCAN0	D03	D02	D01	D00	(KST0 ↑)
SCAN1	D13	D12	D11	D10	(KST1 ↑)
SCAN2	D23	D22	D21	D20	(KST2 ↑)
SCAN3	D33	D32	D31	D30	(KST3 ↑)
SCAN4	D43	D42	D41	D40	(KST4 ↑)
SCAN5	D53	D52	D51	D50	(KST5 ↑)
SCAN6	D63	D62	D61	D60	(KST6 ↑)
SCAN7	D73	D72	D71	D70	(KST7 ↑)

Figure 26 Key Scan Register Configuration

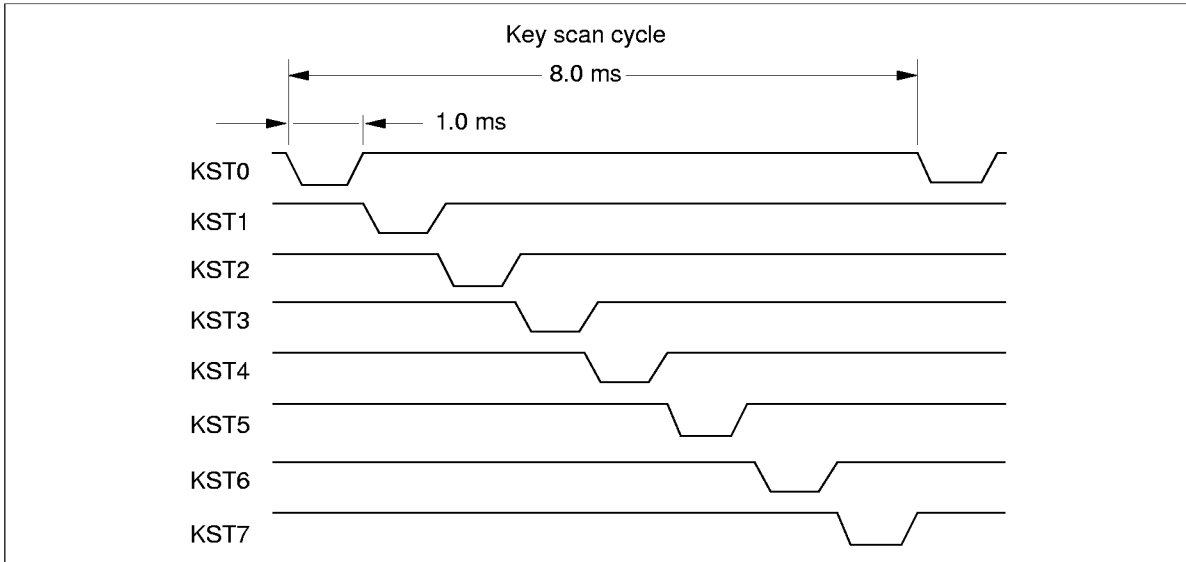

Figure 27 Key Strobe Output Timing (NL1 = 1, KF1/0 = 10, fcp/fosc = 160 kHz)

Table 28 Key Scan Cycles for Each Operating Frequency

Register	Key Scan Cycle							
	NL1	KF1	KF0	Clock Cycle	160 kHz	120 kHz	80 kHz	40 kHz
0 (1, 2 lines)	0	0	160		(1.0 ms)*	(1.3 ms)*	2.0 ms	4.0 ms
0 (1, 2 lines)	0	1	320		(2.0 ms)*	(2.7 ms)*	4.0 ms	8.0 ms
0 (1, 2 lines)	1	0	640		(4.0 ms)*	(5.3 ms)*	8.0 ms	16.0 ms
0 (1, 2 lines)	1	1	1,280		(8.0 ms)*	(10.7 ms)*	16.0 ms	32.0 ms
1 (3, 4 lines)	0	0	320		2.0 ms	2.7 ms	(4.0 ms)*	(8.0ms)*
1 (3, 4 lines)	0	1	640		4.0 ms	5.3 ms	(8.0ms)*	(16.0ms)*
1 (3, 4 lines)	1	0	1,280		8.0 ms	10.7 ms	(16.0 ms)*	(32.0ms)*
1 (3, 4 lines)	1	1	2,560		16.0 ms	21.3 ms	(32.0 ms)*	(64.0ms)*

Note: * Reference value

In order to compensate for the mechanical features of the keys, such as chattering and noise and for the key-strobe generation cycle and the pulse width of the HD66727, software should read the scanned data two or three times in succession to obtain valid data. Multiple keypress combinations should also be processed in software. Up to three keys can be pressed simultaneously. Note, however, that if the third key is pressed on an intersection between the rows and columns of the first two keys pressed, incorrect data will be sampled. For three-key input, the third key must be on a separate column and row.

The input pins KIN0 to KIN3 are pulled up to V_{CC} with internal MOS transistors (see the Electrical Characteristics section). External resistors may also be required to further pull up the voltages when the internal pull-ups are insufficient for the desired noise margins or for a large key matrix.

Key Scan Data Transfer

The key-scanned data can be read by an MPU via a serial interface as shown in Figure 28. First, a start byte should be transferred. After the HD66727 has received the start byte, the MPU reads scan data SD0 to SD3 from the SCAN0 register starting from the MSB. Similarly, the MPU reads data from SCAN1, SCAN2, SCAN3, SCAN4, SCAN5, SCAN6, and SCAN7 in that order. After reading SCAN7, the MPU starts at SCAN0 again. While reading the scanned data, the MPU also reads the scan flags (SF1 and SF0) and the transfer flag (TF). The scan flags reflect the value of the scan cycle counter, which automatically increments its value by one for each scan cycle from 00 to 11 (after 11, it is reset to 00). If the scan data is read more than once to be confirmed, and the corresponding scan counter values are the same, the scan data might have been erroneously latched into the scan register at the same timing; it should be reconfirmed as required. Also, if the transfer flag is read as 1, the HD66727 has been read out while it is latching scan data and is thus unstable; it should also be reconfirmed as required.

a) Scan Data Read Timing through Clock-Synchronized Serial Bus Interface

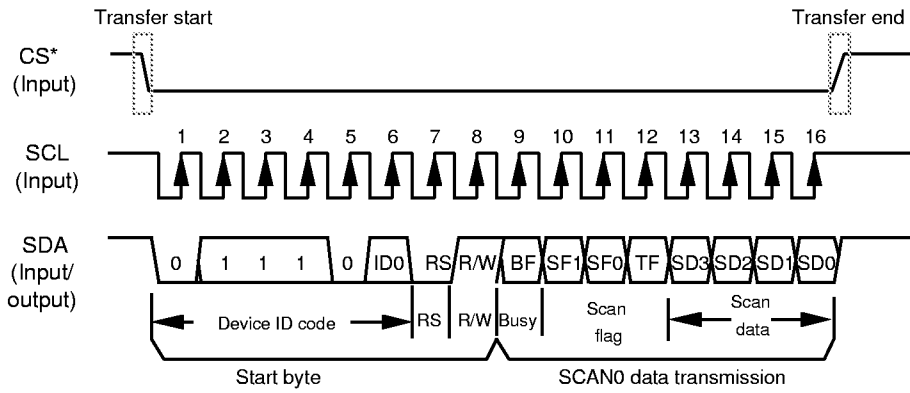

b) Scan Data Read Timing through I2C Bus Interface

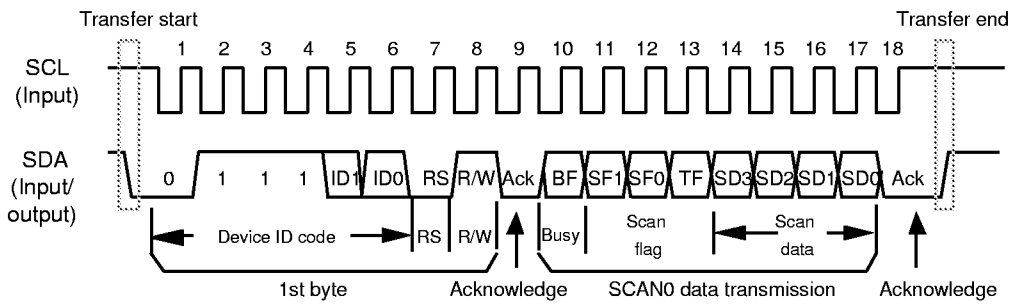

c) Consecutive Scan Data Read Timing

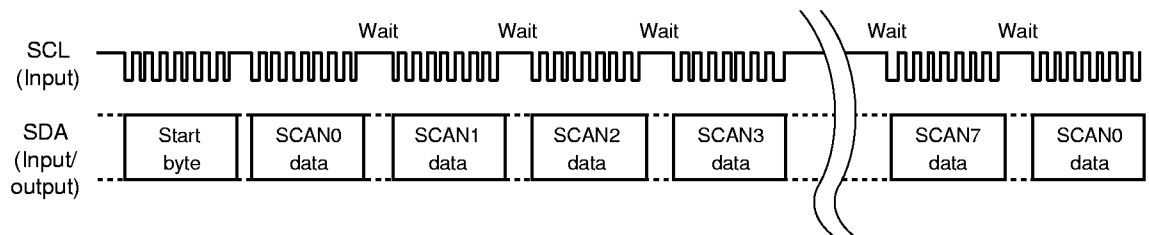

Figure 28 Scan Data Serial Transfer Timing

Key Scan Interrupt (Wake-Up Function)

If the interrupt enable bit (IRE) is set to 1, the HD66727 sends an interrupt signal to the MPU on detecting that a key has been pressed in the key scan circuit by setting the IRQ* output pin to a low level. An interrupt signal can be generated by pressing any key in a 32-key matrix. The interrupt level continues to be output during the key scan cycle in which the key is being pressed. See Figure 29.

Normal key scanning is performed and interrupts can occur in the HD66727 sleep mode (SLP = 1). Accordingly, power consumption can be minimized in the sleep mode, where only annunciators can be displayed, by triggering the MPU to read key states via the interrupt generated only when the HD66727 detects a key input from the 32-key matrix. For details, refer to the Sleep Mode section.

On the other hand, normal key scanning and the internal operating clock are halted in the standby mode (STB = 1). During this period, the KST0 output is kept low, so the HD66727 can always sense four key inputs D00 to D03, connected with KIN0 to KIN3, respectively. Therefore, if any of the four keys is pressed in the standby mode, an interrupt occurs. Accordingly, power consumption can be further minimized in the standby mode, where the whole system is inactive, by triggering the MPU via the interrupt generated only when the HD66727 detects a key input from the above four keys. Note that the interrupt generated in the standby mode automatically starts internal R-C oscillation. For details, refer to the Standby Mode section.

The IRQ* output pin is pulled up to the V_{CC} with an internal MOS resistor of approximately 50 k Ω ; additional external resistors may be required to obtain stronger pull-ups. Interrupts may occur if noise occurs in KIN input during key scanning. Interrupts must be inhibited if not needed by setting the interrupt enable bit (IRE) to 0.

Figure 30 shows key scan interrupt processing flow in sleep and standby modes.

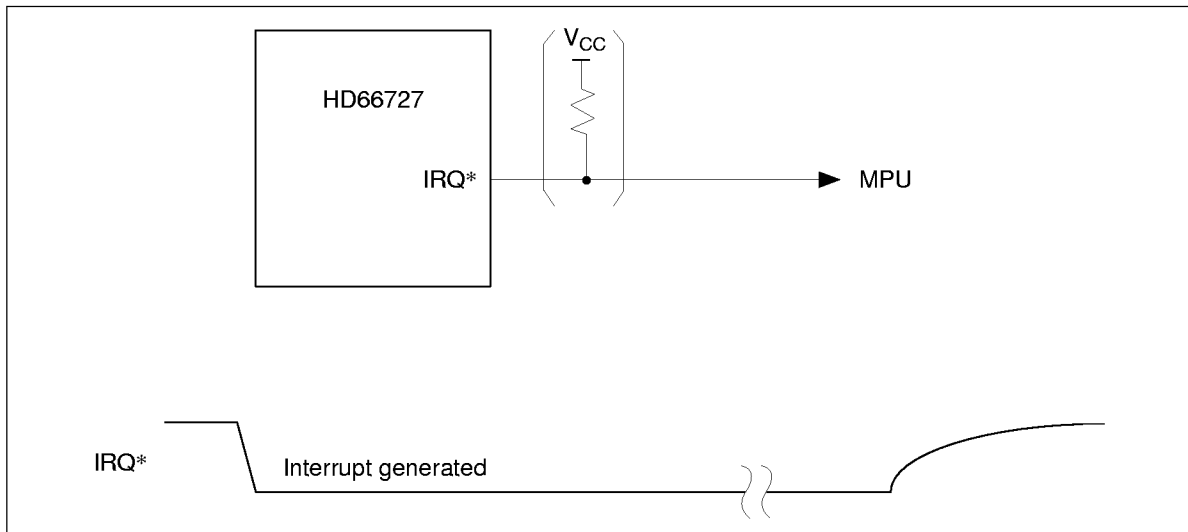

Figure 29 Interrupt Generation

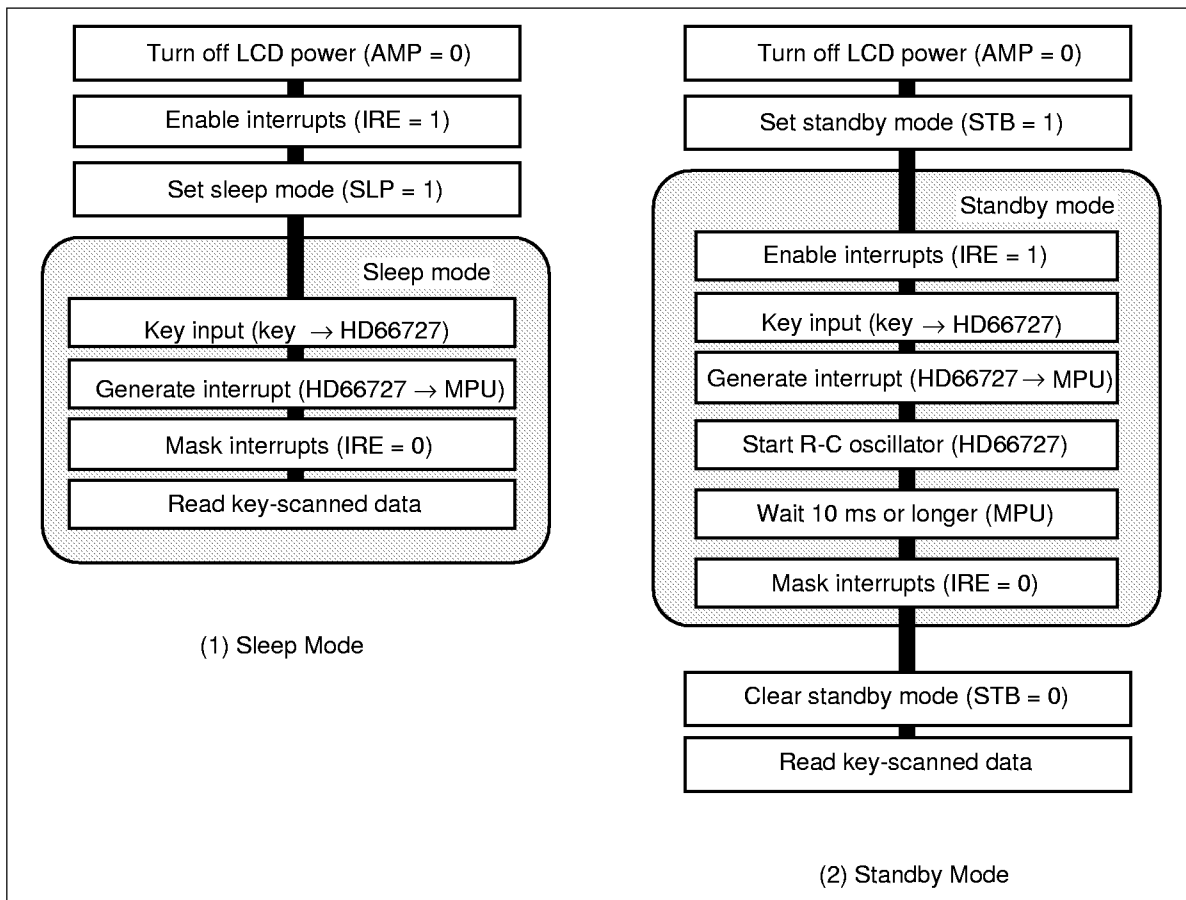

Figure 30 Key Scan Interrupt Processing Flow in Sleep and Standby Modes

Oscillator Circuit

The HD66727 can either be supplied with operating clock pulses externally (external clock mode) or oscillate using an internal R-C oscillator and an external oscillator-resistor (internal oscillation mode), as shown in Figure 31. An appropriate oscillator-resistor must be used to obtain the optimum clock frequency according to the number of display lines (Table 29). Instruction execution times change in proportion to the operating clock frequency or R-C oscillation frequency; MPU data transfer rate must be appropriately adjusted (see Table 23, Instruction List). Figure 32 shows a sample LCD drive output waveform, where 4-lines are displayed with 1/34 multiplexing duty ratio.

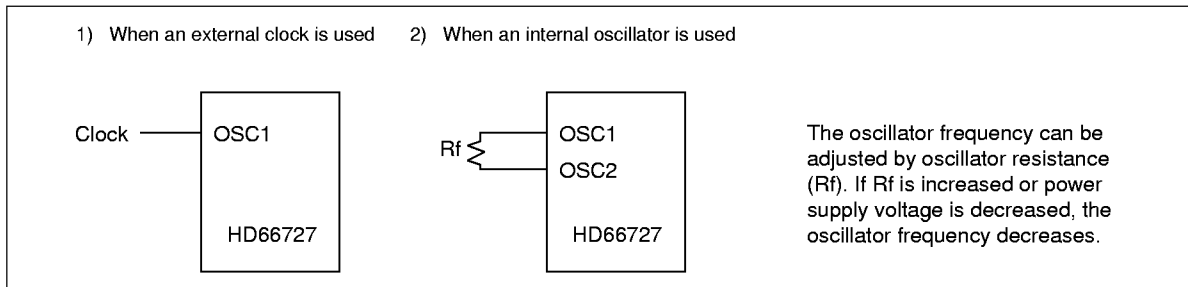

Figure 31 Oscillator Circuit

Table 29 Oscillation Frequency and LCD Frame Frequency

Item	1-Line Display (NL1, NL0 = 00)	2-Line Display (NL1, NL0 = 01)	3-Line Display (NL1, NL0 = 10)	4-Line Display (NL1, NL0 = 11)
Multiplexing duty ratio	1/10	1/18	1/26	1/34
R-C oscillation frequency (recommended value)	40 kHz	80 kHz	120 kHz	160 kHz
1-line drive frequency	0.66 kHz	1.3 kHz	2.0 kHz	2.7 kHz
Frame frequency	67 Hz	74 Hz	77 Hz	78 Hz

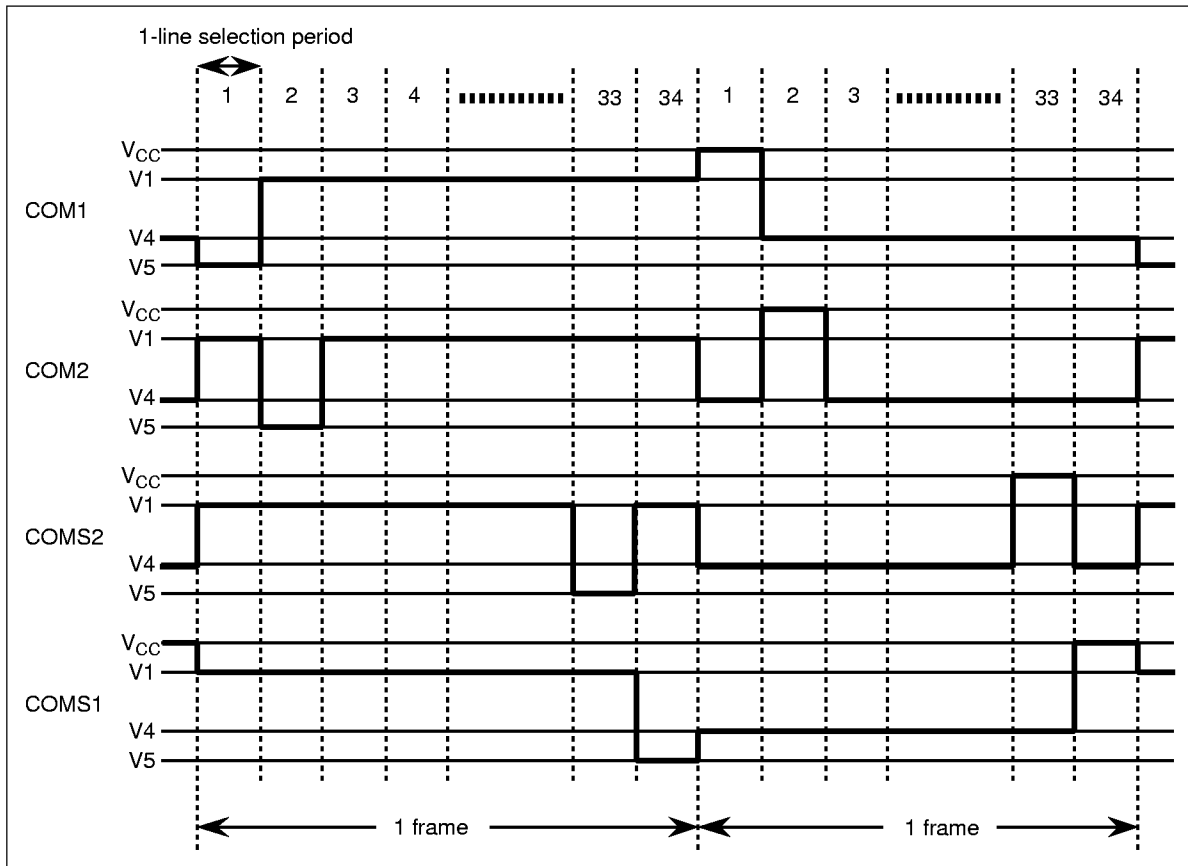

Figure 32 LCD Drive Output Waveform Example (4-line display with 1/34 multiplexing duty ratio)

Power Supply for Liquid Crystal Display Drive

When External Power Supply and Internal Operational Amplifiers are Used

To supply LCD drive voltage directly from the external power supply without using the internal booster, circuits should be connected as shown in Figure 33. Here, contrast can be adjusted through the CT bits of the contrast control instruction.

The HD66727 incorporates a voltage-follower operational amplifier for each of V1 to V5 to reduce current flowing through the internal bleeder-resistors, which generate different levels of liquid-crystal drive voltages. Thus, potential differences between V_{CC} and V1 and between V_{EE} and V5 must be 0.4V or greater. Note that the OPOFF pin must be grounded when using the operational amplifiers.

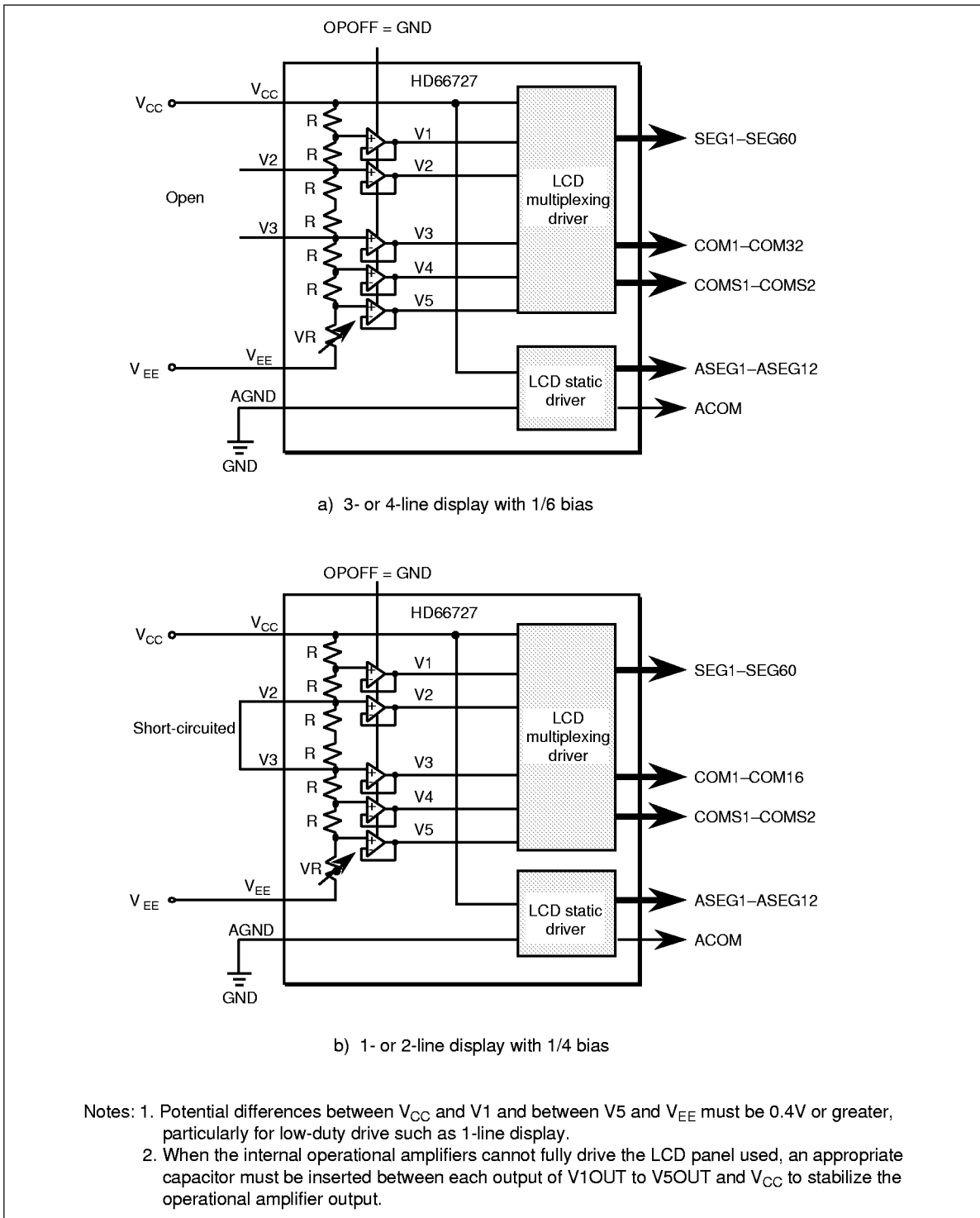

Figure 33 External Power Supply Circuit Example for LCD Drive Voltage Generation

When an Internal Booster and Internal Operational Amplifiers are Used

To supply LCD drive voltage using the internal booster, circuits should be connected as shown in Figure 34. Here, contrast can be adjusted through the CT bits of the contrast control instruction. Temperature can be compensated either through the CT bits or by controlling the reference voltage for the booster (Vci pin) using a thermistor.

Note that Vci is both a reference voltage and power supply for the booster; the reference voltage must therefore be adjusted using an emitter-follower or a similar element so that sufficient current can be supplied. In this case, Vci must be equal to or smaller than the V_{CC} level.

The HD66727 incorporates a voltage-follower operational amplifier for each of V1 to V5 to reduce current flowing through the internal bleeder-resistors, which generate different levels of liquid-crystal drive voltages. Thus, potential differences between V_{CC} and V1 and between V_{EE} and V5 must be 0.4V or greater. Note that the OPOFF pin must be grounded when using the operational amplifiers.

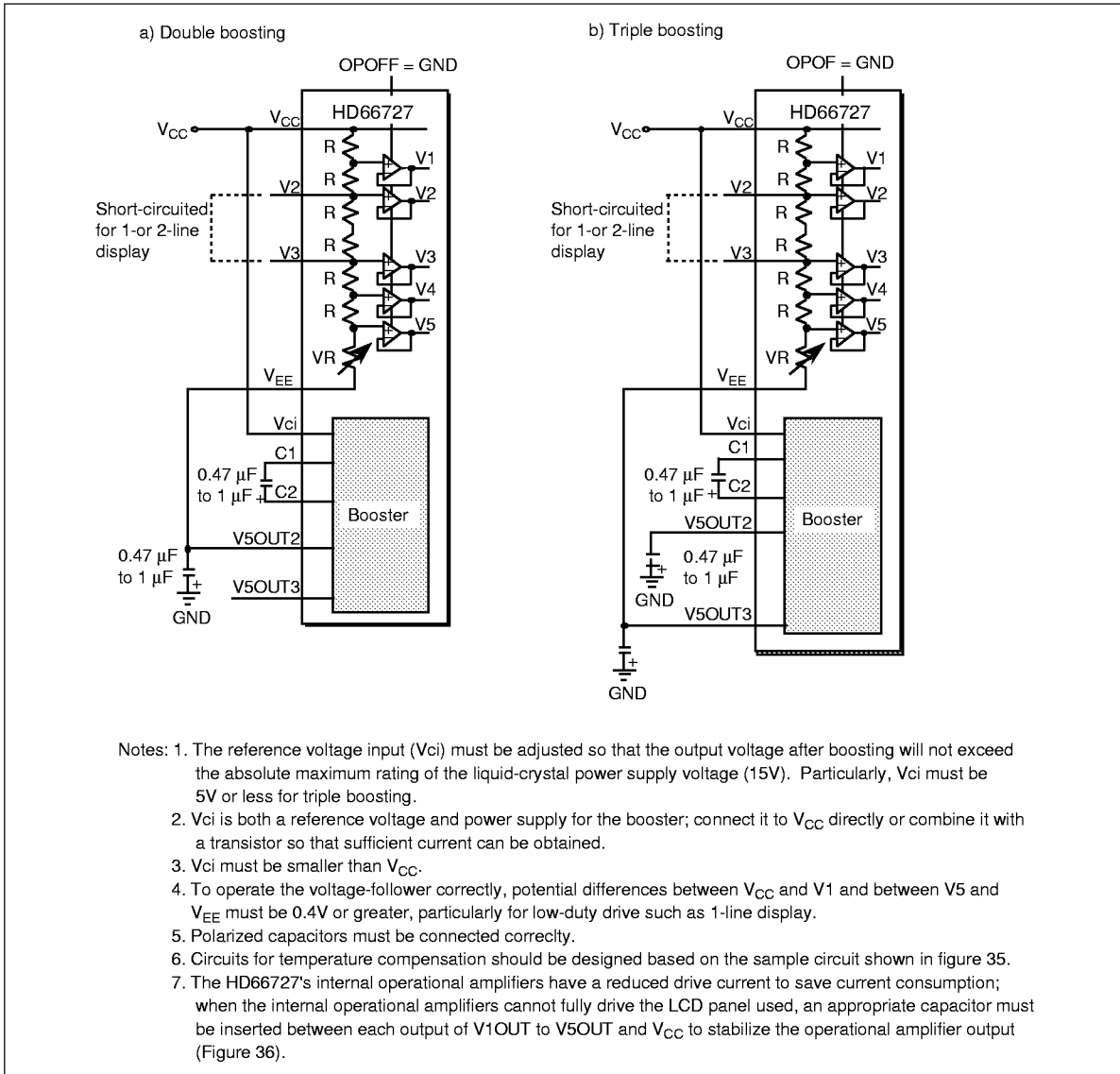

Figure 34 Internal Power Supply Circuit Example for LCD Drive Voltage Generation

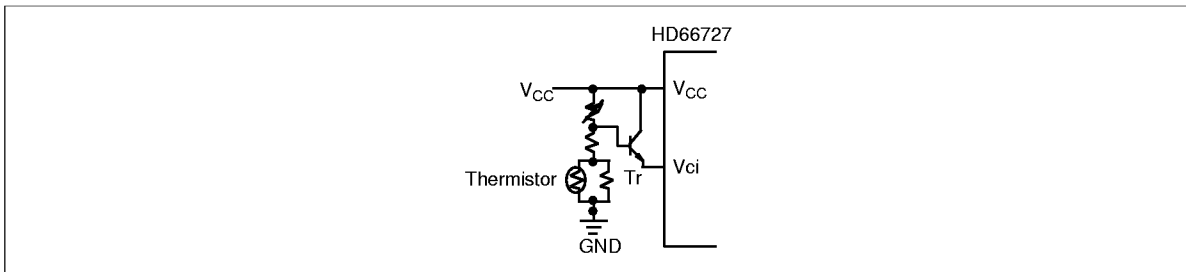

Figure 35 Temperature Compensation Circuit Example

Example of Using Internal Operational Amplifier when Driving Large Size of LCD

The driving current of the internal operational amplifier in the HD66727 is reduced to control the consumption current. When load current is apparently large such as when driving large size of LCD panel, insert a capacitor between V1OUT–V5OUT outputs and V_{CC} power supply, and stabilize the output level of the operational amplifier. Especially the capacitors for V1OUT and V4OUT must be inserted when 1/26 duty or 1/34 duty drives.

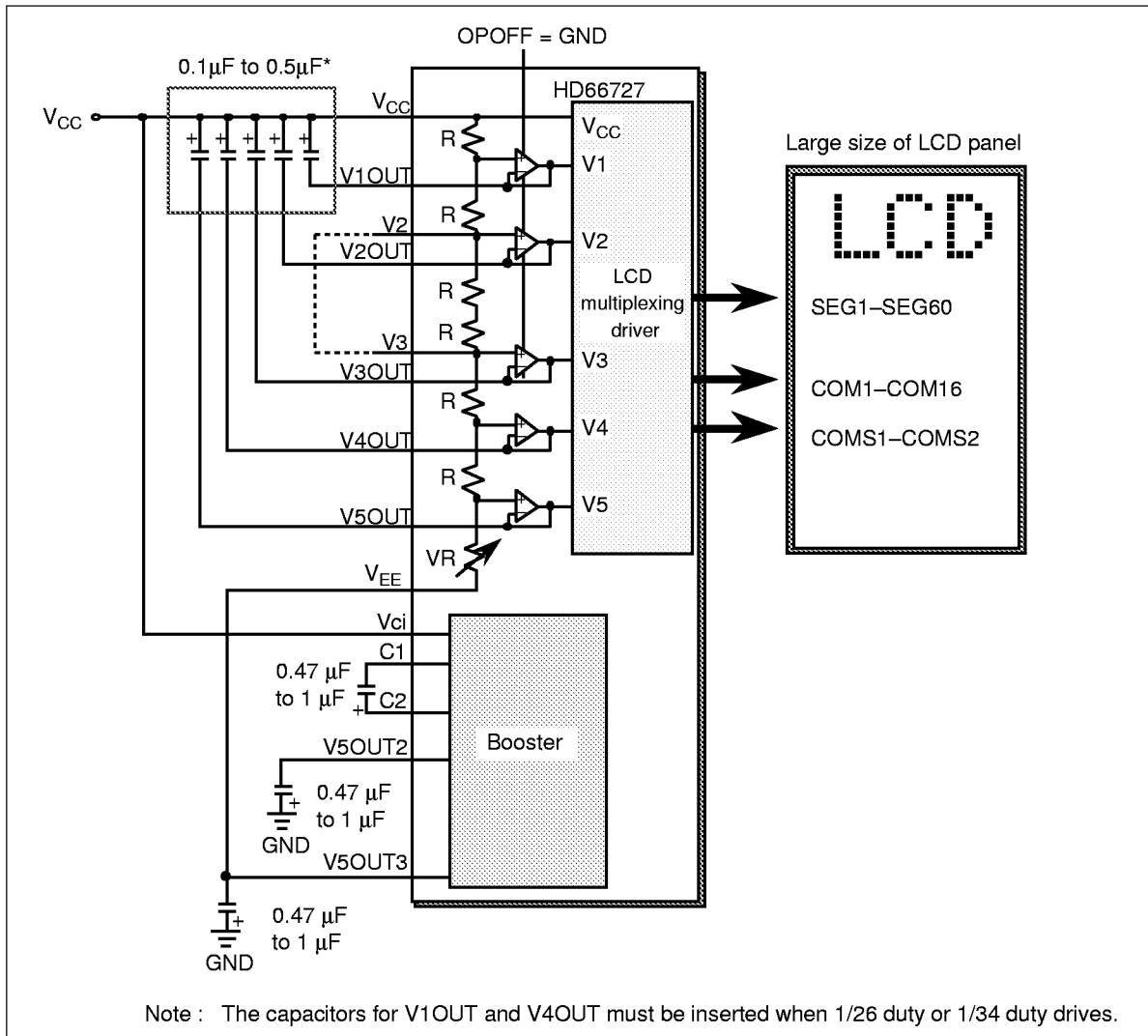

Figure 36 Operational Amplifier Output Stabilization Circuit Example when Driving Large Size of LCD Panel

HD66727

LCD driving current (I_{EE})*2	When 1/10, 1/18-duty drive (1 line, 2 lines)	When 1/26, 1/34-duty drive (3 lines, 4 lines)
When $I_{EE} \leq 15 \mu\text{A}$	Capacitors for V1OUT to V5OUT must be inserted.	Capacitors for V1OUT to V5OUT must be inserted.
When $15 \mu\text{A} \leq I_{EE} \leq 40 \mu\text{A}$	Capacitors for V1OUT and V4OUT must be inserted.	Capacitors for V1OUT and V4OUT must be inserted.
When $I_{EE} \geq 40 \mu\text{A}$	Capacitors for V1OUT and V4OUT may be inserted after confirming the display quality.	And additional capacitors for other VnOUTs may be inserted after confirming the display quality.

- Notes:
1. These relationships between LCD driving current (I_{EE}) and the external capacitors are applied to designing LCM, but they cannot guarantee the practical display quality. This display quality depends on LCD panel size and LCD material used, and it must be checked and confirmed with your LCD panel.
 2. These LCD driving currents (I_{EE}) depend on the LCD driving voltage between V_{CC} and V_{EE} , and setting of VREF, VREFP and VREFP pins.
 3. Especially the capacitors for V1OUT and V4OUT are most efficient for display quality.
 4. This condition is an example when the frame frequency is 60Hz to 100Hz. If higher frame frequency is used, these external capacitors should be enhanced to prevent the cross-talk.

When an Internal Booster and External Bleeder-Resistors are Used

When the internal operational amplifiers cannot fully drive the LCD panel used, V1 to V5 voltages can be supplied through external bleeder-resistors (Figure 37). Here, the OPOFF pin must be set to the V_{CC} level to turn off the internal operational amplifiers. Since the internal contrast adjuster is disabled in this case, contrast must be adjusted externally. Double- and triple-boosters can be used as they are.

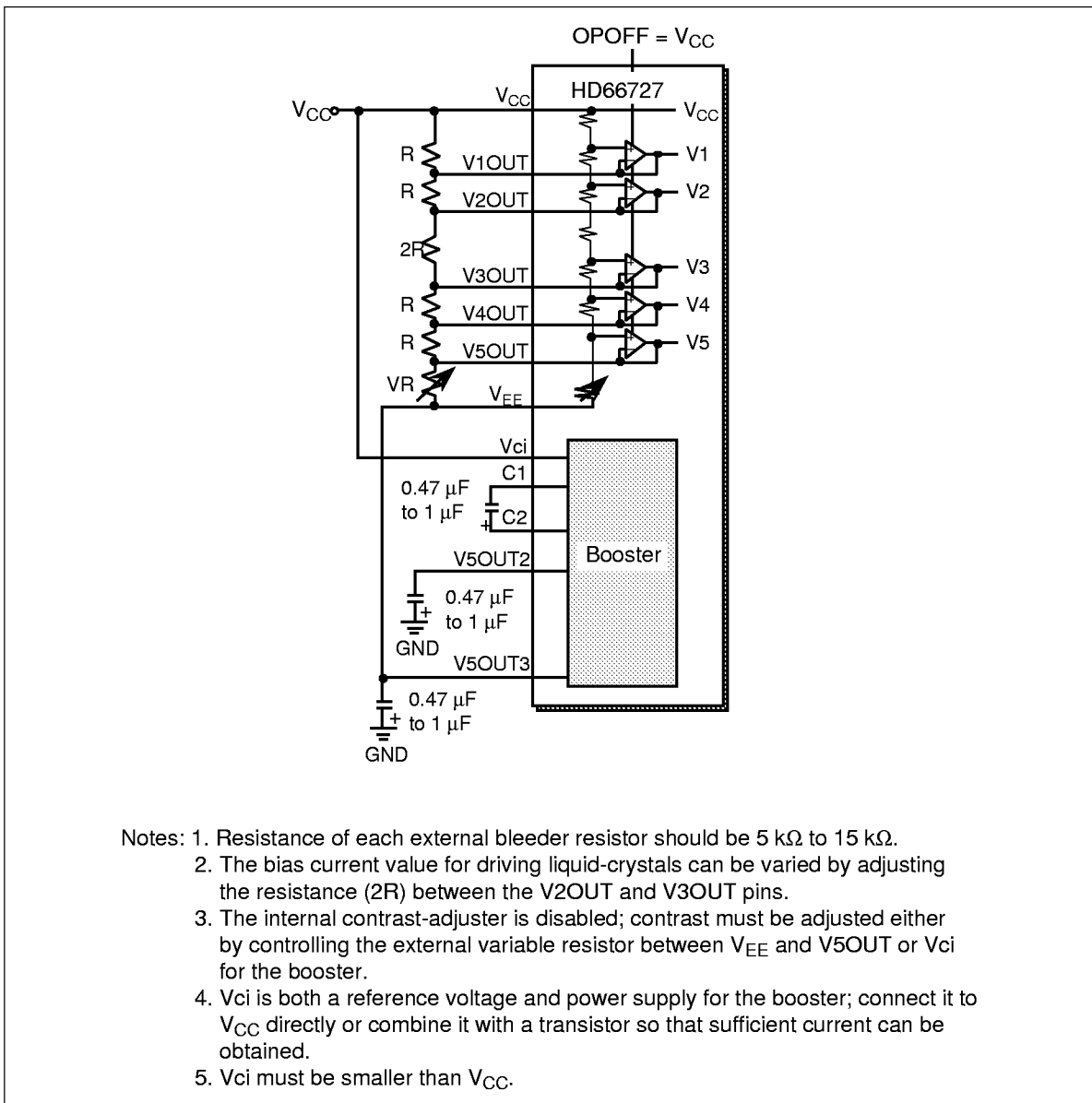

Figure 37 Power Supply Circuit Example Using External Bleeder-Resistor for LCD Drive Voltage Generation

Contrast Adjuster

Multiplexing Drive System

Contrast for an LCD controlled by the multiplexing drive method can be adjusted by varying the liquid-crystal drive voltage (potential difference between V_{CC} and V5) through the CT bits of the contrast control instruction (electron volume function). See Figure 38 and Table 30. The value of a variable resistor (VR) can be adjusted within the range from $0.4 \times R$ through $6.4 \times R$, where R is a reference resistance obtained by dividing the total resistance between V_{CC} and V5.

The HD66727 incorporates a voltage-follower operational amplifier for each of V1 to V5 to reduce current flowing through the internal bleeder-resistors, which generate different levels of liquid-crystal drive voltages. Thus, potential differences between V_{CC} and V1 and between V_{EE} and V5 must be 0.4V or greater. Note that the OPOFF pin must be grounded when using the operational amplifiers.

1/6 bias (V2 and V3 pins left open):

LCD drive voltage VLCD: $6R \times (V_{CC} - V_{EE}) / (6R + VR)$ (VR = a value within the range from 0.4R to 6.4R)

VLCD adjustable range: $0.484 \times (V_{CC} - V_{EE}) \leq VLCD \leq 0.938 \times (V_{CC} - V_{EE})$

Potential difference between V_{CC} and V1: $R \times (V_{CC} - V_{EE}) / (6R + VR) \geq 0.4$ (V)

Potential difference between V5 and V_{EE} : $VR \times (V_{CC} - V_{EE}) / (6R + VR) \geq 0.4$ (V)

1/4 bias (V2 and V3 pins short-circuited):

LCD drive voltage VLCD: $4R \times (V_{CC} - V_{EE}) / (4R + VR)$ (VR = a value within the range from 0.4R to 6.4R)

VLCD adjustable range: $0.385 \times (V_{CC} - V_{EE}) \leq VLCD \leq 0.909 \times (V_{CC} - V_{EE})$

Potential difference between V_{CC} and V1: $R \times (V_{CC} - V_{EE}) / (4R + VR) \geq 0.4$ (V)

Potential difference between V5 and V_{EE} : $VR \times (V_{CC} - V_{EE}) / (4R + VR) \geq 0.4$ (V)

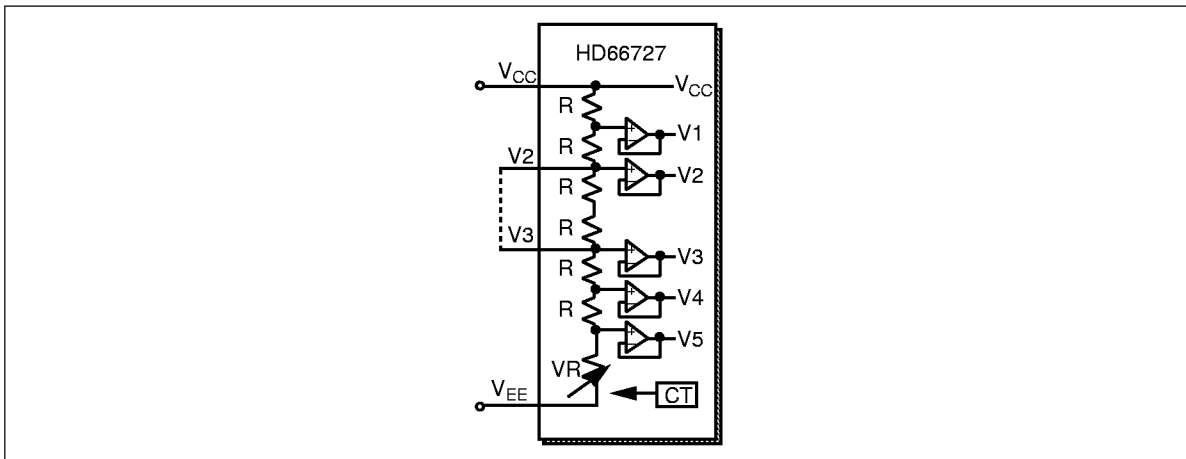

Figure 38 Contrast Adjuster

Table 30 Contrast-Adjust Bits (CT) and Variable Resistor Values

CT3	CT2	CT1	CT0	Variable Resistor Value (VR)
0	0	0	0	6.4 R
0	0	0	1	6.0 R
0	0	1	0	5.6 R
0	0	1	1	5.2 R
0	1	0	0	4.8 R
0	1	0	1	4.4 R
0	1	1	0	4.0 R
0	1	1	1	3.6 R
1	0	0	0	3.2 R
1	0	0	1	2.8 R
1	0	1	0	2.4 R
1	0	1	1	2.0 R
1	1	0	0	1.6 R
1	1	0	1	1.2 R
1	1	1	0	0.8 R
1	1	1	1	0.4 R

Static Drive System

Contrast for a statically-driven LCD, that is, annunciator display, can be adjusted through the AGND pin. The annunciators are driven statically by the potential difference between V_{CC} and AGND. The AGND pin level must be equal to or greater than the GND level.

HD66727

LCD Panel Interface

The HD66727 can change the shift direction of common drivers COM1–COM32 and COMS1 and COMS2 and segment drivers SEG1–SEG60 with the CMS and SGS bits. These bits can be selected according to the mounting method such as the chip arrangement or wire leading. However, the output position of annunciator drivers ASEG1–ASEG12 cannot be changed, so adjust it by software.

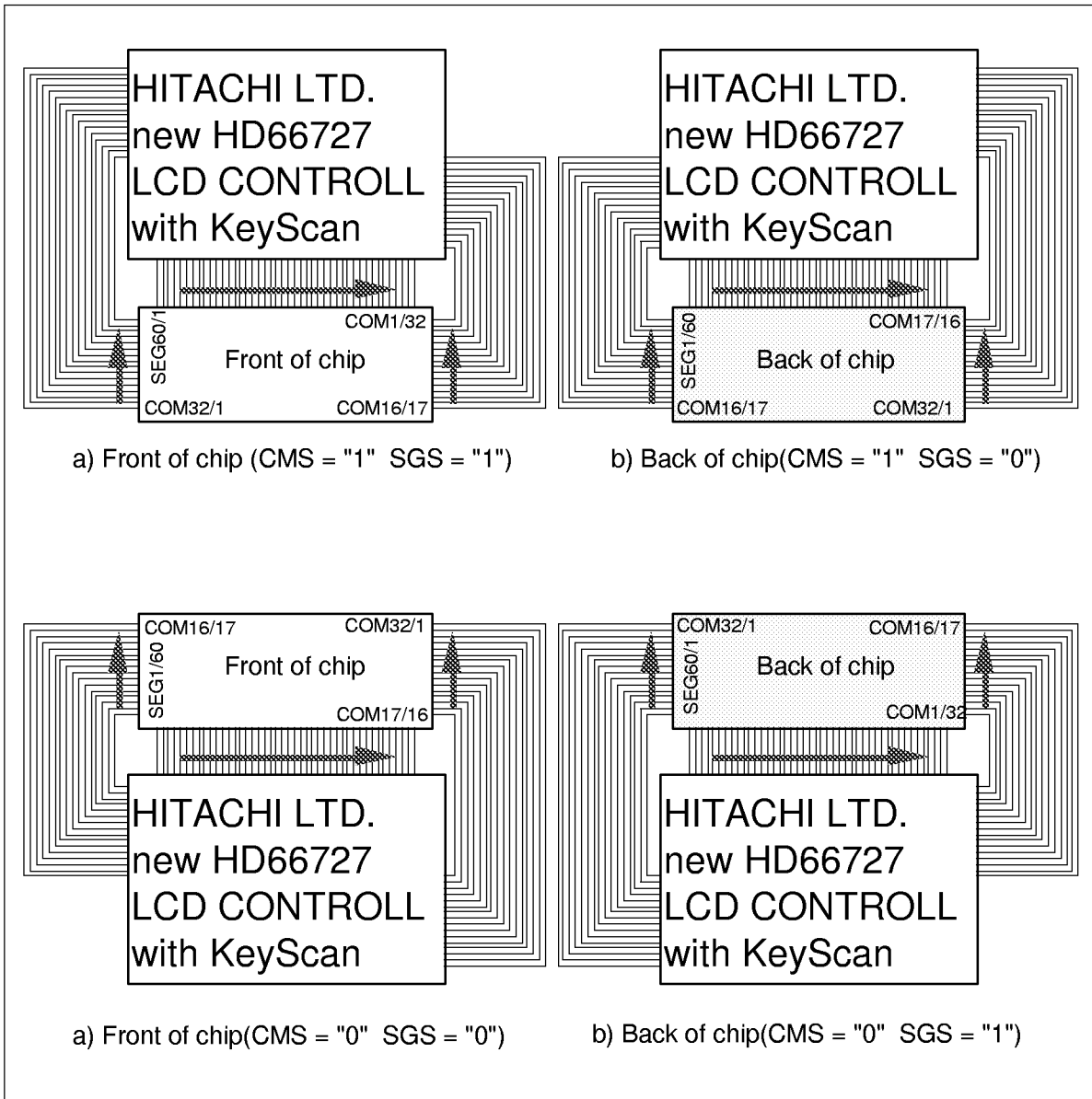

Figure 39 LCD Module Interface Examples

Segment Display and Annunciator Display

The HD66727 provides both segment display, which is driven by the multiplexing method, and annunciator display, which is driven statically. Annunciator display is driven at a logic operating voltage ($V_{CC} - AGND$) and is thus also available while the LCD drive power supply is turned off. Accordingly, annunciator display is suitable for displaying marks during system standby, when it is desirable to reduce current consumption. It is available in the sleep mode, where internal multiplexing operations for character or segment display are halted. If an alternating signal is supplied to the EXM pin, it is also available in the standby mode, where the internal R-C oscillator is halted. Here, AGND must be equal to or above the GND level.

Note that annunciator display cannot share character display drivers SEG and COM but require special drivers ASEG and ACOM that require long routing.

Tables 31 to 34 compare segment display to annunciator display. Figure 40 shows annunciator drive output waveforms in two modes.

Table 31 Comparison between Segment Display and Annunciator Display

Item	Segment Display	Annunciator Display
Number of driven elements	40 each by 5-dot font width 48 each by 6-dot font width	12
Blinking	Impossible	Possible
Segment drivers	SEG1–SEG60 (shared with character display)	ASEG1–ASEG12 (independent of character display)
Common drivers	COMS1, COMS2	ACOM
LCD power supply	$V_{CC} - V_5$ (LCD power supply necessary)	$V_{CC} - AGND$ (LCD power supply unnecessary)
Normal mode display	Possible together with character display by multiplexing drive	Possible by static drive
Sleep mode display	Impossible (SEG and COM output V_{CC})	Possible by static drive
Standby mode display (without oscillation)	Impossible (SEG and COM output V_{CC})	Possible by supplying alternating signal to the EXM pin

HD66727

Table 32 Correspondence between Segment Display SEGRAM Addresses (ASEG) and Driver Signals when 5-Dot Font Width

ASEG Address				Common Signal	Segment Signal				
MSB	LSB				Bit 4	Bit 3	Bit 2	Bit 1	Bit 0
1	0	0	0	COMS1	SEG1/21/41	SEG2/22/42	SEG3/23/43	SEG4/24/44	SEG5/25/45
1	0	0	1	COMS1	SEG6/26/46	SEG7/27/47	SEG8/28/48	SEG9/29/49	SEG10/30/50
1	0	1	0	COMS1	SEG11/31/51	SEG12/32/52	SEG13/33/53	SEG14/34/54	SEG15/35/55
1	0	1	1	COMS1	SEG16/36/56	SEG17/37/57	SEG18/38/58	SEG19/39/59	SEG20/40/60
1	1	0	0	COMS2	SEG1/21/41	SEG2/22/42	SEG3/23/43	SEG4/24/44	SEG5/25/45
1	1	0	1	COMS2	SEG6/26/46	SEG7/27/47	SEG8/28/48	SEG9/29/49	SEG10/30/50
1	1	1	0	COMS2	SEG11/31/51	SEG12/32/52	SEG13/33/53	SEG14/34/54	SEG15/35/55
1	1	1	1	COMS2	SEG16/36/56	SEG17/37/57	SEG18/38/58	SEG19/39/59	SEG20/40/60

Table 33 Correspondence between Segment Display SEGRAM Addresses (ASEG) and Driver Signals when 6-Dot Font Width

ASEG Address				Common Signal	Segment Signal							
MSB	LSB				Bit 7	Bit 6	Bit 5	Bit 4	Bit 3	Bit 2	Bit 1	Bit 0
1	0	0	0	COMS1	*	*	SEG1/25/49	SEG2/26/50	SEG3/27/51	SEG4/28/52	SEG5/29/53	SEG6/30/54
1	0	0	1	COMS1	*	*	SEG7/31/55	SEG8/32/56	SEG9/33/57	SEG10/34/58	SEG11/35/59	SEG12/36/60
1	0	1	0	COMS1	*	*	SEG13/37	SEG14/38	SEG15/39	SEG16/40	SEG17/41	SEG18/42
1	0	1	1	COMS1	*	*	SEG19/43	SEG20/44	SEG21/45	SEG22/46	SEG23/47	SEG24/48
1	1	0	0	COMS2	*	*	SEG1/25/49	SEG2/26/50	SEG3/27/51	SEG4/28/52	SEG5/29/53	SEG6/30/54
1	1	0	1	COMS2	*	*	SEG7/31/55	SEG8/32/56	SEG9/33/57	SEG10/34/58	SEG11/35/59	SEG12/36/60
1	1	1	0	COMS2	*	*	SEG13/37	SEG14/38	SEG15/39	SEG16/40	SEG17/41	SEG18/42
1	1	1	1	COMS2	*	*	SEG19/43	SEG20/44	SEG21/45	SEG22/46	SEG23/47	SEG24/48

Table 34 Correspondence between Annunciator Display Addresses (AAN) and Driver Signals

AAN Address				Common Signal	Segment Signal			
MSB	LSB				Bits 7, 6	Bits 5, 4	Bits 3, 2	Bits 1, 0
0	0	0	0	ACOM	ASEG1	ASEG2	ASEG3	ASEG4
0	0	0	1	ACOM	ASEG5	ASEG6	ASEG7	ASEG8
0	0	1	0	ACOM	ASEG9	ASEG10	ASEG11	ASEG12

Note: The annunciator is turned on when the corresponding even bit (bit 6, 4, 2, or 0) is 1, and the turned-on annunciator blinks when the corresponding odd bit (bit 7, 5, 3, or 1) is 1.

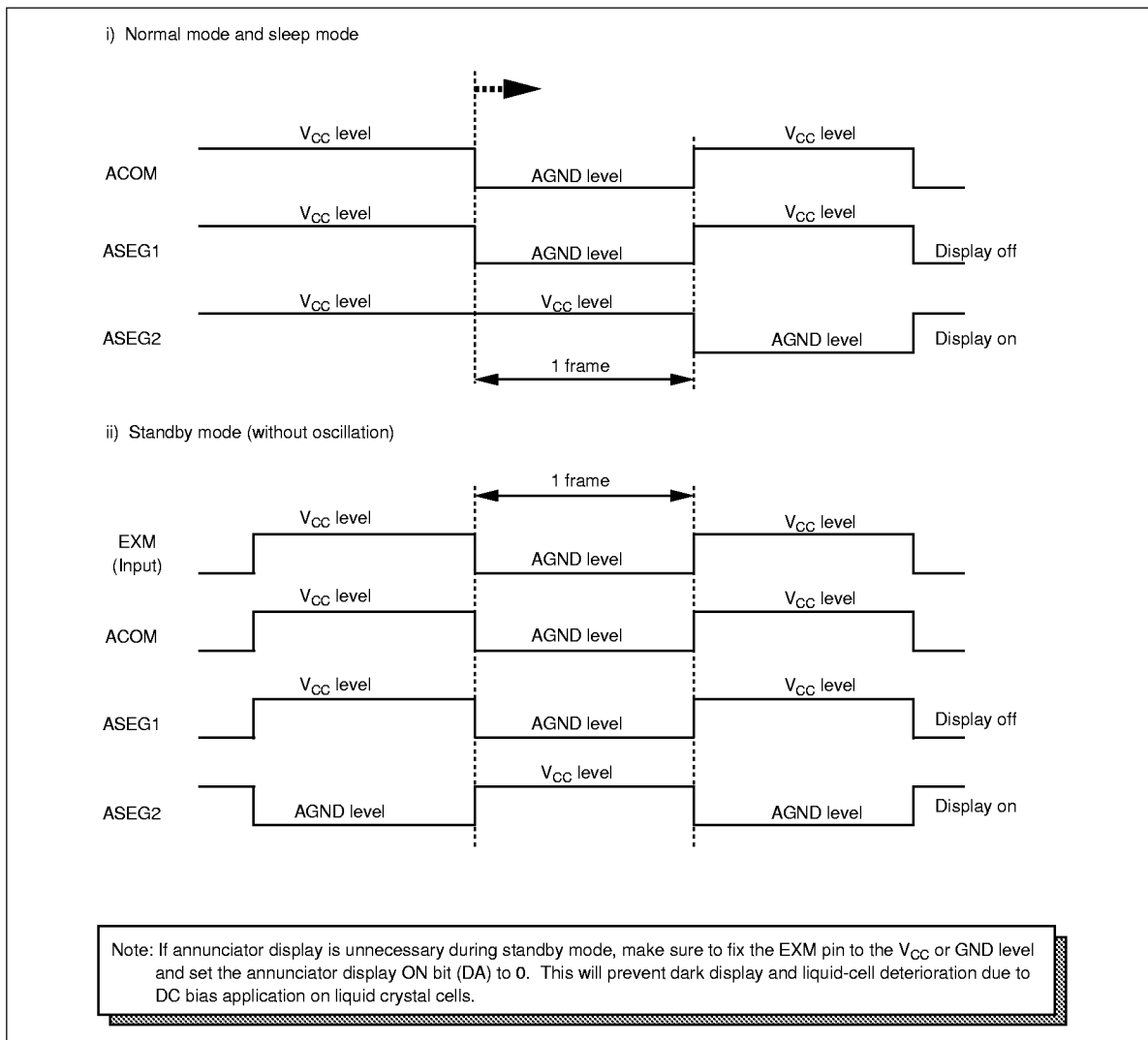

Figure 40 Annunciator Drive Output Waveforms

Vertical Smooth Scroll

The HD66727 can scroll in the vertical direction in units of raster-rows. This function is achieved by writing character codes into DDRAM area that is not being used for display. In other words, since DDRAM corresponds to a 5-line \times 12-character display, one of the lines can be used to achieve continuous smooth vertical scroll even in a 4-line display. Here, after the fifth line is displayed, the first line is displayed again. Specifically, this function is controlled by incrementing or decrementing the value in the display-start line bits (SL2 to SL0) and display-start raster-row bits (SN2 to SN0) by 1. For example, to smoothly scroll up, first set SN2 to SN0 to 000, and increment SL2 to SL0 by 1 from 000 to 111 to scroll seven raster-rows. Then increment SN2 to SN0 to 001, and again increment SL2 to SL0 by 1 from 000 to 111. To start displaying and scrolling from the first raster-row of the second line, update the first line of DDRAM data as desired during its non-display period.

Figure 41 shows an example of vertical smooth scrolling and Figure 42 shows an example of setting instructions for vertically scrolling upward in a 4-line display (NL1 and NL0 = 11).

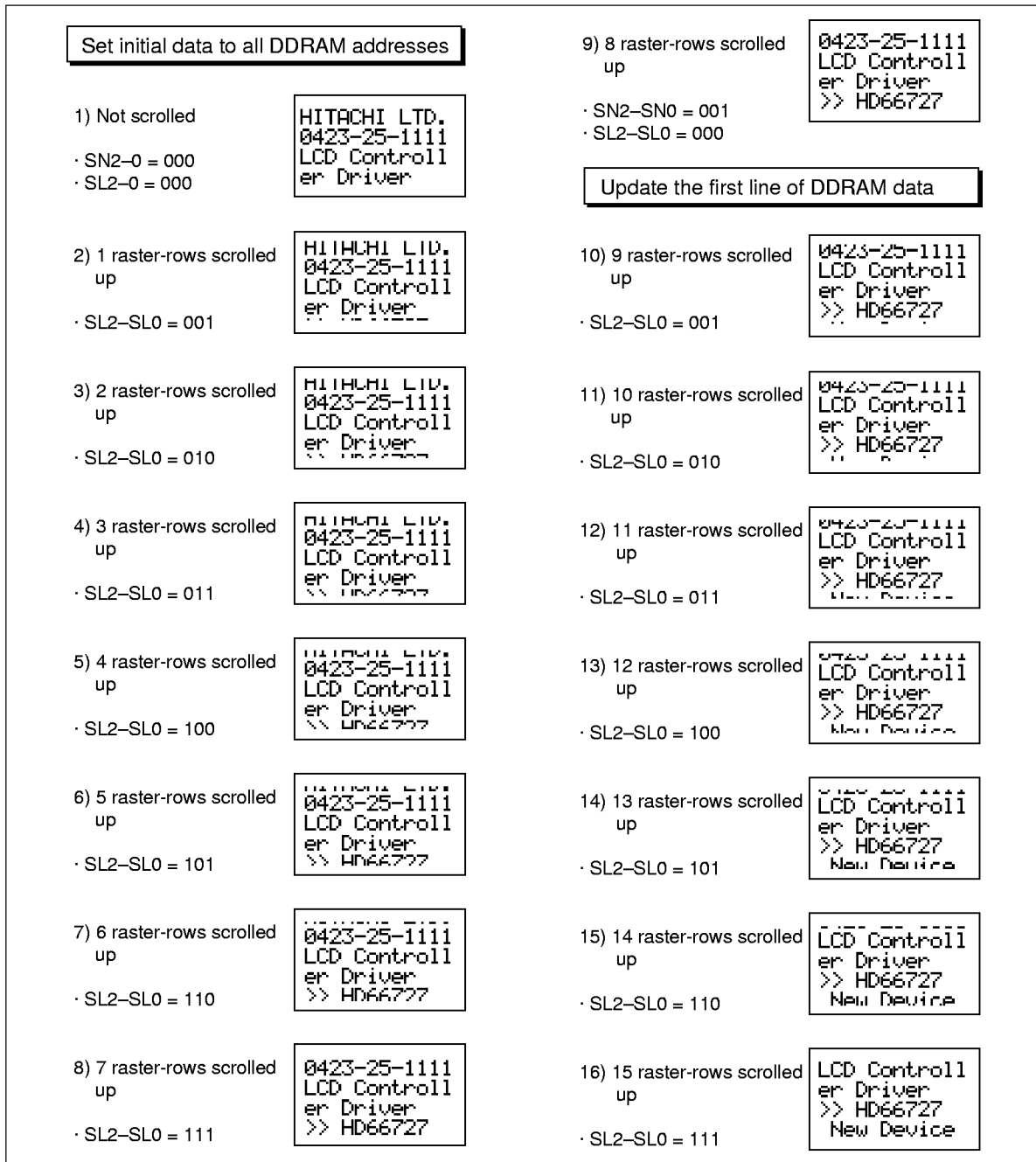
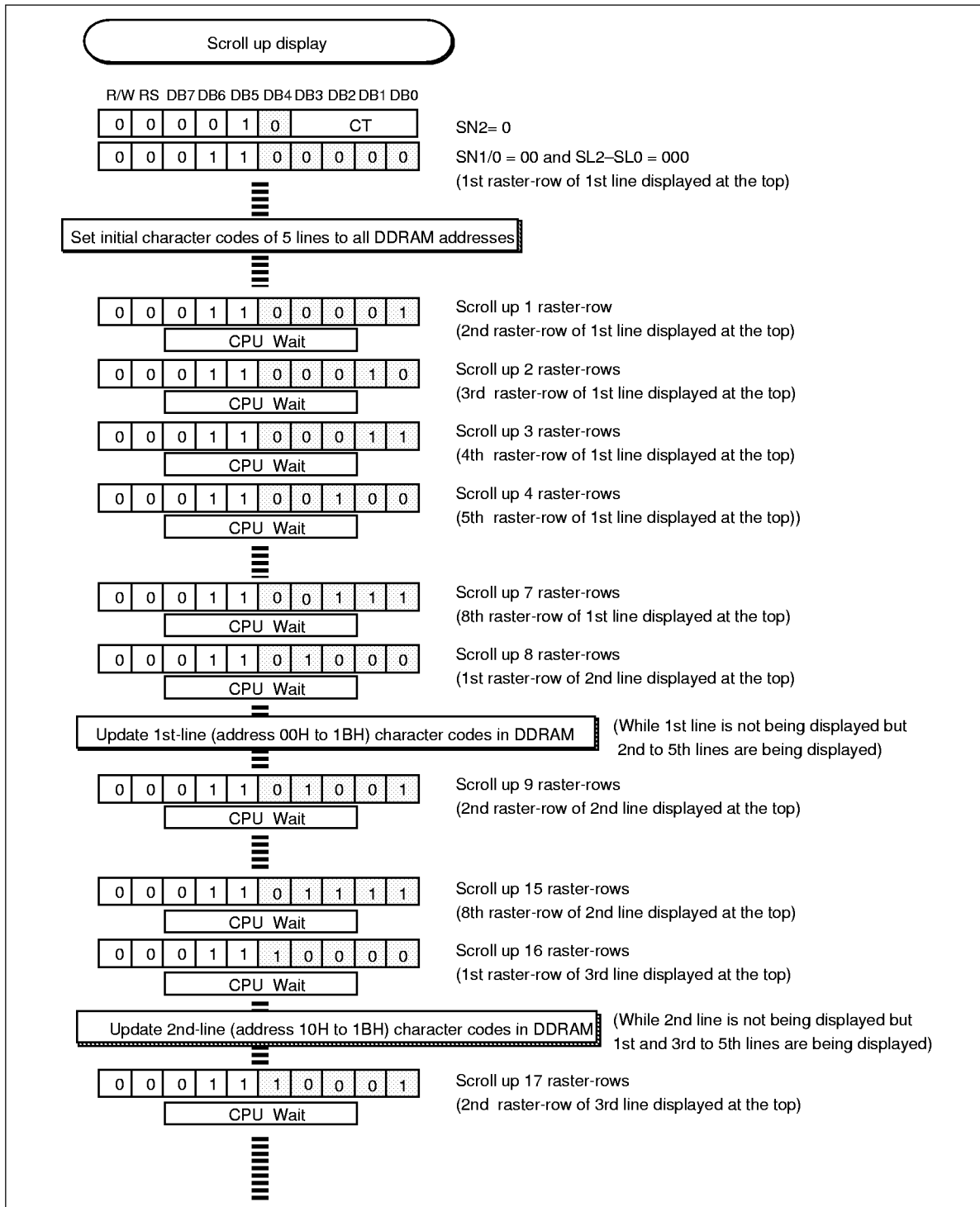

Figure 41 Example of Vertical Smooth Scrolling



**Figure 42 Example of Setting Instructions for Vertical Smooth Scroll
(4-line display (NL1 and NL0 = 11))**

Line-Cursor Display

The HD66727 can assign a cursor attribute to an entire line corresponding to the address counter value by setting the LC bit to 1 (Table 35). One of three line-cursor modes can be selected: a black-white inverting blink cursor (B/W = 1), an underline cursor (C = 1), and a blink cursor (B = 1). The blink cycle for a black-white inverting cursor and for a blink cursor is 32 frames. These line-cursors are suitable for highlighting an index and/or marker, and for indicating an item in a menu with a cursor or an underline.

Figures 43 to 45 show three line-cursor examples.

Table 35 Address Counter Value and Line-Cursor

Address Counter Value (AC)	Selected Line for Line-Cursor
"00"H to "0B"H	Entire 1st line (12 characters)
"10"H to "1B"H	Entire 2nd line (12 characters)
"20"H to "2B"H	Entire 3rd line (12 characters)
"30"H to "3B"H	Entire 4th line (12 characters)
"40"H to "4B"H	Entire 5th line (12 characters)

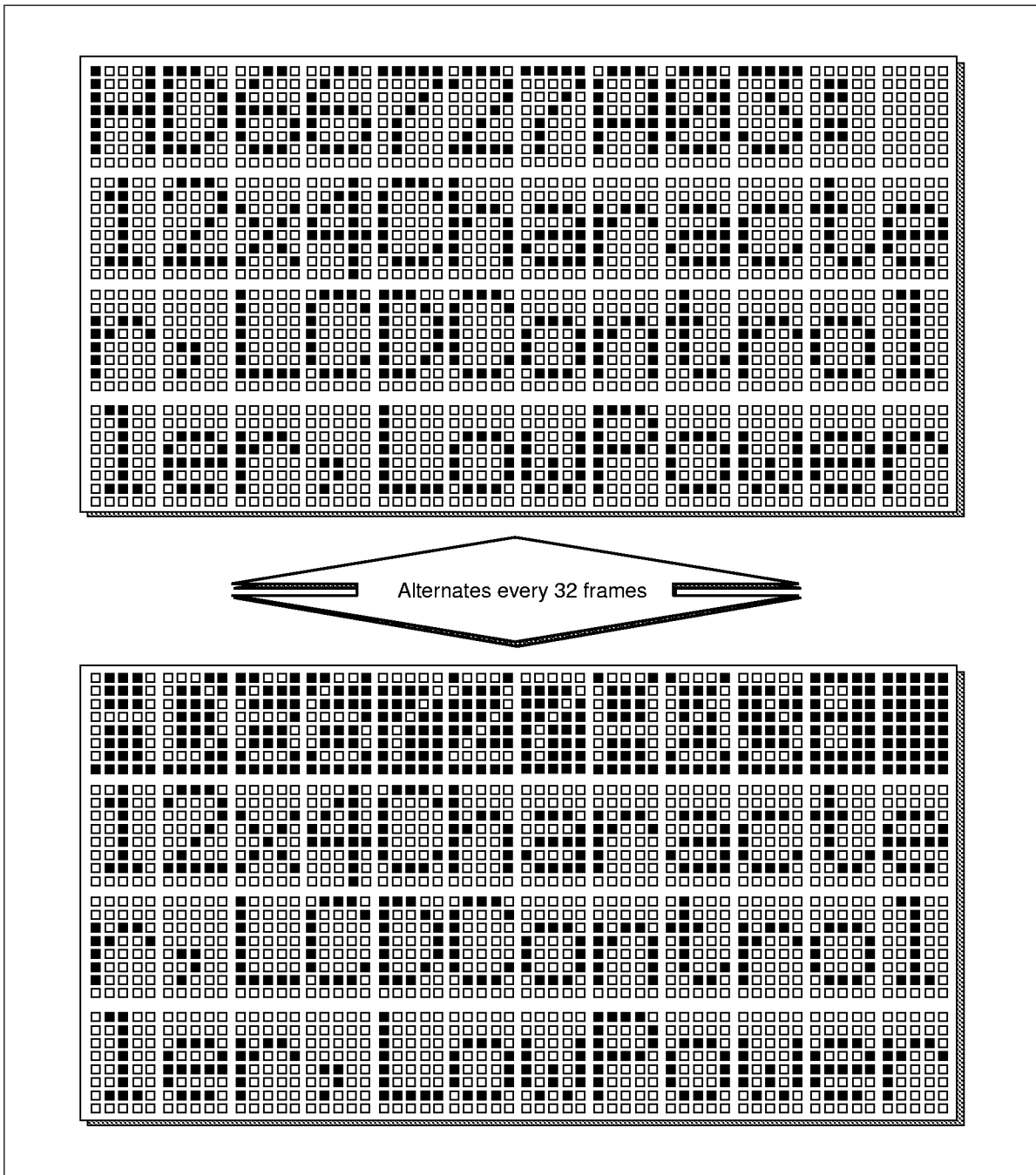

Figure 43 Example of Black-White Inverting Blink Cursor (LC = 1; B/W = 1)

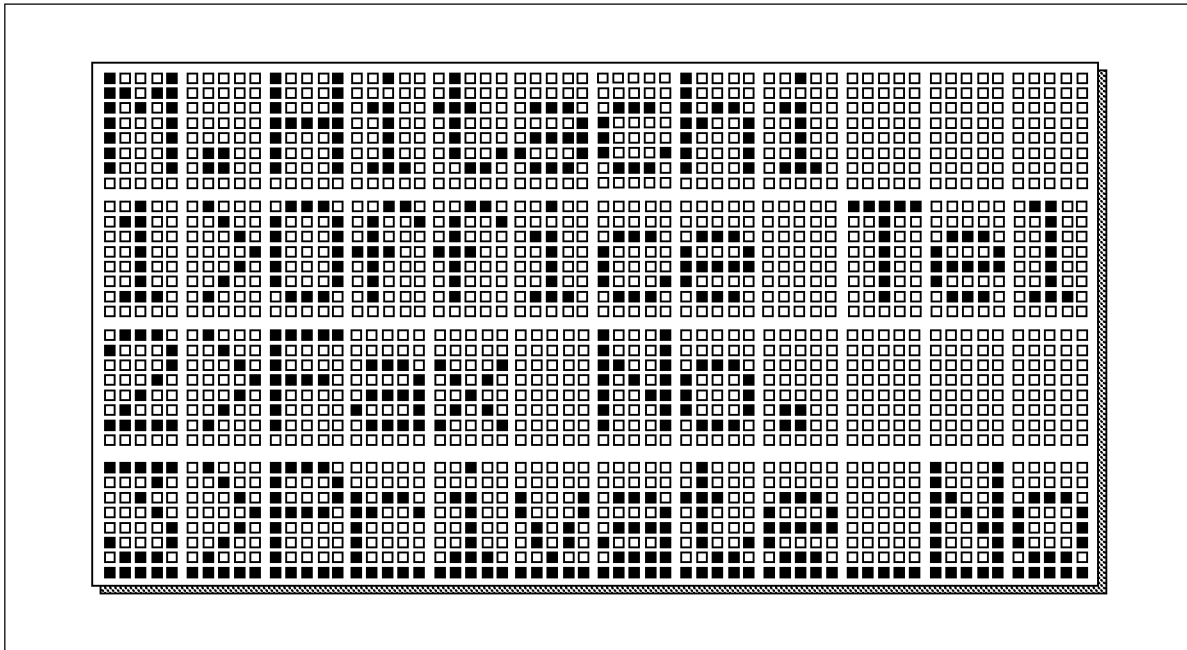

Figure 44 Example of Underline Cursor (LC = 1; C = 1)

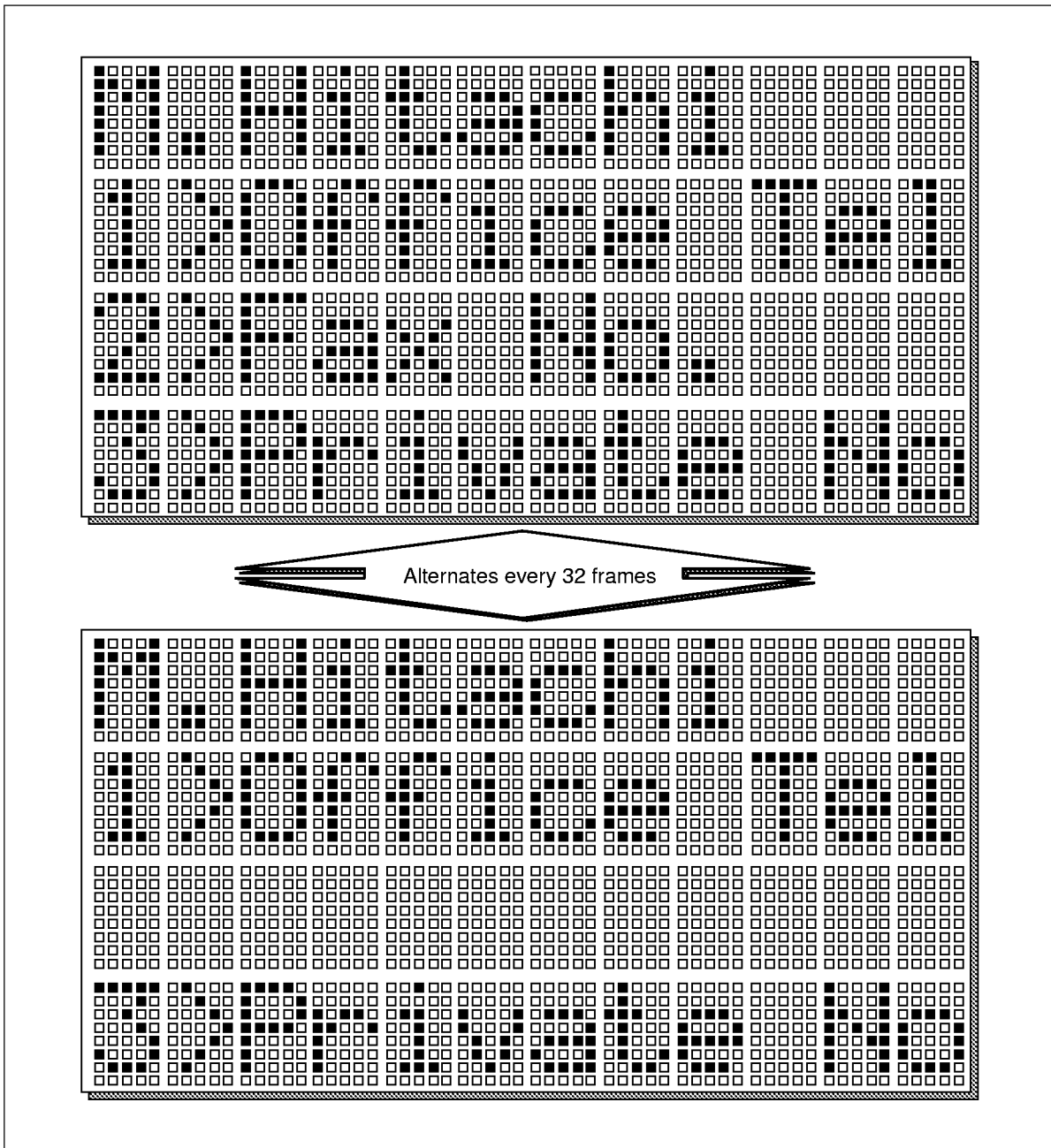

Figure 45 Example of Blink Cursor (LC = 1; B = 1)

Double-Height Display

The HD66727 can double the height of any desired line from the first to third lines. A line can be selected by the DL3 to DL1 bits as listed in Table 36. All the standard font characters stored in the CGROM and CGRAM can be doubled in height, providing an easy-to-see display. Note that there should be no space between lines for double-height display (Figure 46).

Table 36 Double-Height Display Specifications

DL3	DL2	DL1	2-Line Display (NL1, NL0 = 01)	3-Line Display (NL1, NL0 = 10)	4-Line Display (NL1, NL0 = 11)
0	0	0	1st & 2nd lines: normal	1st to 3rd lines: normal	1st to 4th lines: normal
0	0	1	1st line: double-height	1st line: double-height 2nd line: normal	1st line: double-height 2nd & 3rd lines: normal
0	1	0	Disabled	2nd line: double-height 1st line: normal	2nd line: double-height 1st & 3rd lines: normal
0	1	1	1st line: double-height	Disabled	1st & 2nd lines: double-height
1	0	0	1st & 2nd lines: normal	Disabled	3rd line: double-height 1st & 2nd lines: normal
1	0	1	1st line: double-height	1st line: double-height 2nd line: normal	Disabled
1	1	0	Disabled	2nd line: double-height 1st line: normal	Disabled
1	1	1	1st line: double-height	Disabled	1st & 2nd lines: double-height

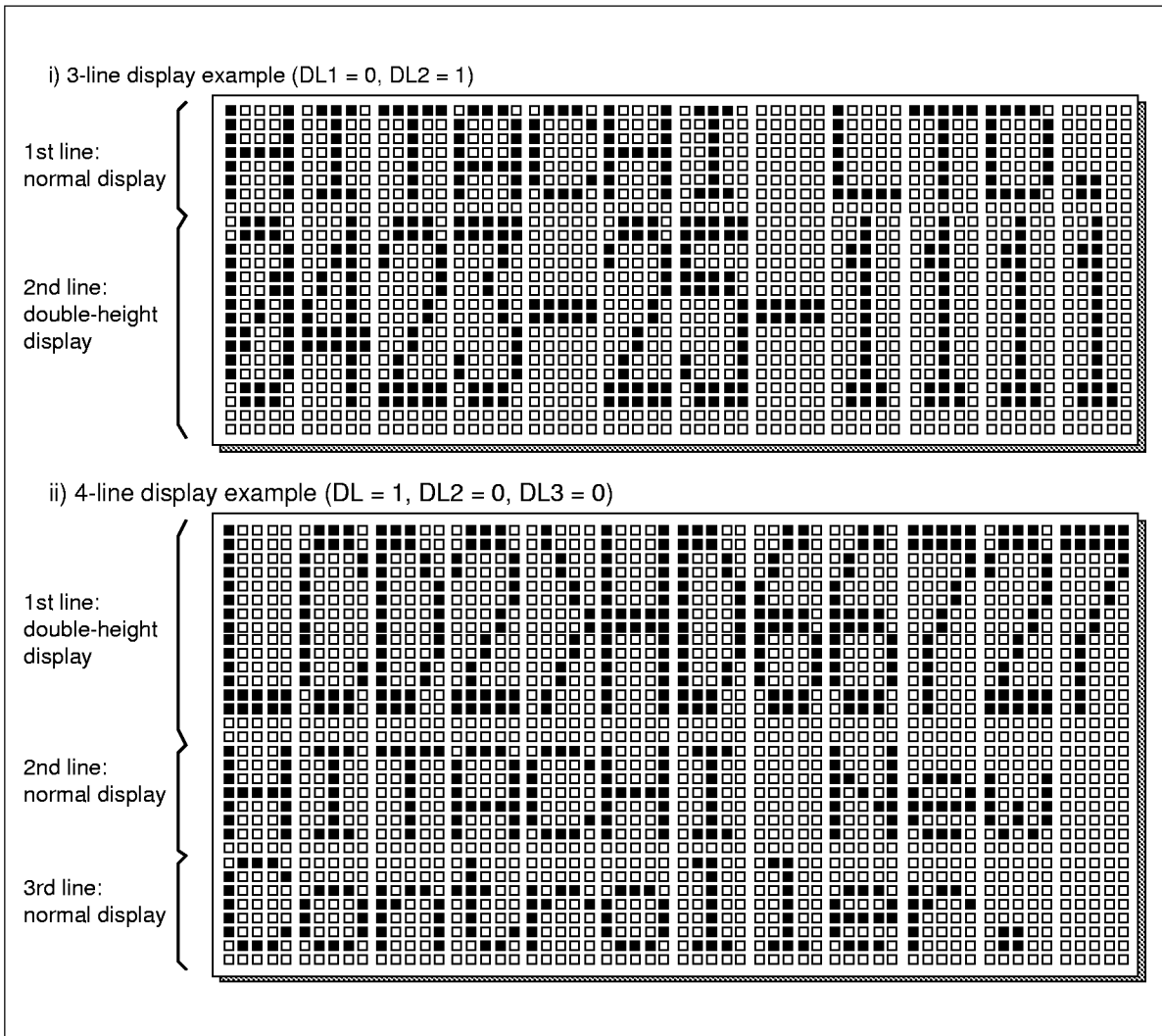

Figure 46 Double-Height Display Examples

Double-Width Display

When the font width bit (FW) is set, the width is 5 dots or 6 dots. When FW = 0, the font width is 5 dots and can be displayed horizontally up to 12 digits. However, the spaces between characters should hold the ITO wiring on the LCD glass. When FW = 1, the font width is 6 dots and can be displayed horizontally up to 10 digits. However, when displaying double-width characters with the font in the CGROM, a special double-width font is needed. In that case, a custom ROM is used.

Double-height characters can be displayed by setting the register in combination with the above double-width display.

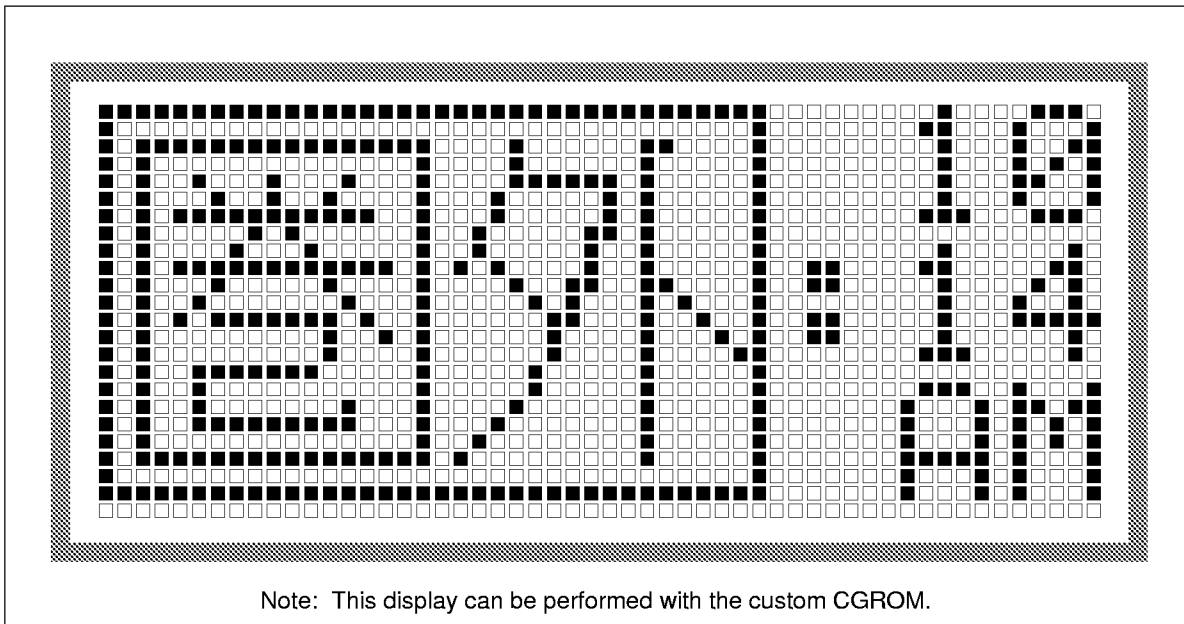

Figure 47 Triple-Width Display Examples

HD66727

LED/Back Light Control

The HD66727 has three LED ports to control the LED and back light, which need current driving, and three general ports, which do not need current driving. However, the sink current in the LED port output is up to 3 mA. If the back light or LED needs more current, increase the current width with the transistor.

Table 37 LED Driving and General Output Port

AAN Address			LED Driving/General Output Port								
MSB	LSB	Bit 7	Bit 6	Bit 5	Bit 4	Bit 3	Bit 2	Bit 1	Bit 0		
0	0	1	1	*	*	PORT2	PORT1	PORT0	LED2	LED1	LED0

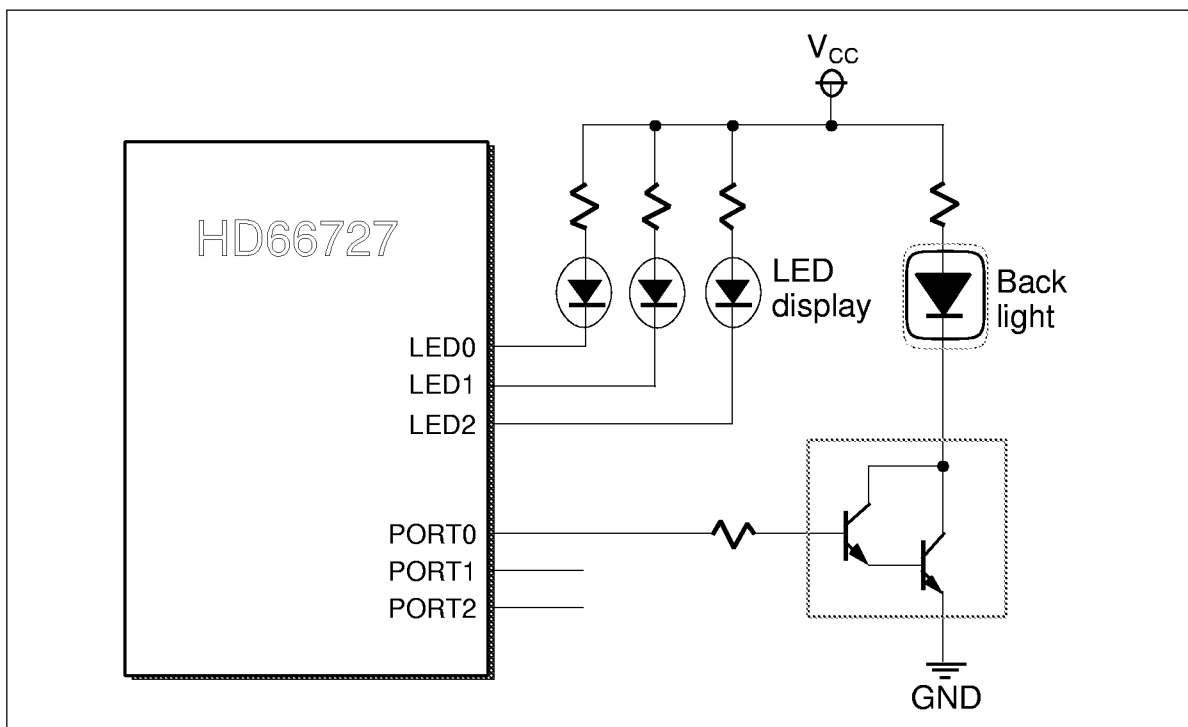

Figure 48 LED Driving Control Circuit Examples

Partial-Display-Off Function

The HD66727 can program the number of display lines (NL bits), divide the internal operating frequency by four (OSC bit), and adjust the display contrast (CT bits). Combining these functions, the HD66727 can turn off the second and/or subsequent lines, displaying only the characters in the first line to reduce internal current consumption (partial-display-off function). This function is suitable for calendar or time display, which needs to be continuous during system standby with minimal current consumption. Here, the second to fourth non-displayed lines are constantly driven by the deselection level voltage, thus turning off the LCD for the lines.

Note that internal clock frequency is reduced to a quarter, quadrupling execution time of each instruction; MPU data transfer rate must be appropriately adjusted. Moreover, as being affected by the NL1 bit and the OSC1 bit, the key-scan cycle for partial-display-off is not the same as that for normal display. Adjust the key-scan cycle by the KF1 and KF0 bits.

Table 38 lists partial-display-off function specifications and Figure 49 shows a sample display using the partial-display-off function

Table 38 Partial-Display-Off Function

Function Item	Normal 4-Line Display	Partially-Off Display
Character display	1st to 4th lines displayed	Only 1st line displayed
Segment display	Possible	Possible
Annunciator display	Possible	Possible
R-C oscillation frequency	160 kHz	160 kHz
Internal operating frequency	160 kHz (OSC = 0)	40 kHz (OSC = 1)
LCD single-line drive frequency	2.7 kHz (1/34 duty ratio)	0.7 kHz (1/10 duty ratio)
Frame frequency	78 Hz	66 Hz
Key scan cycle	320 to 2,560 clock cycles (Clock cycle = 1 / internal operating frequency)	160 to 1,280 clock cycles (Clock cycle = 1 / internal operating frequency)

Note: Select an optimum LCD drive voltage (between V_{CC} and V5) for the multiplexing duty ratio used, using a reference voltage input pin (Vci) for the booster or the contrast adjust bits (CT) .

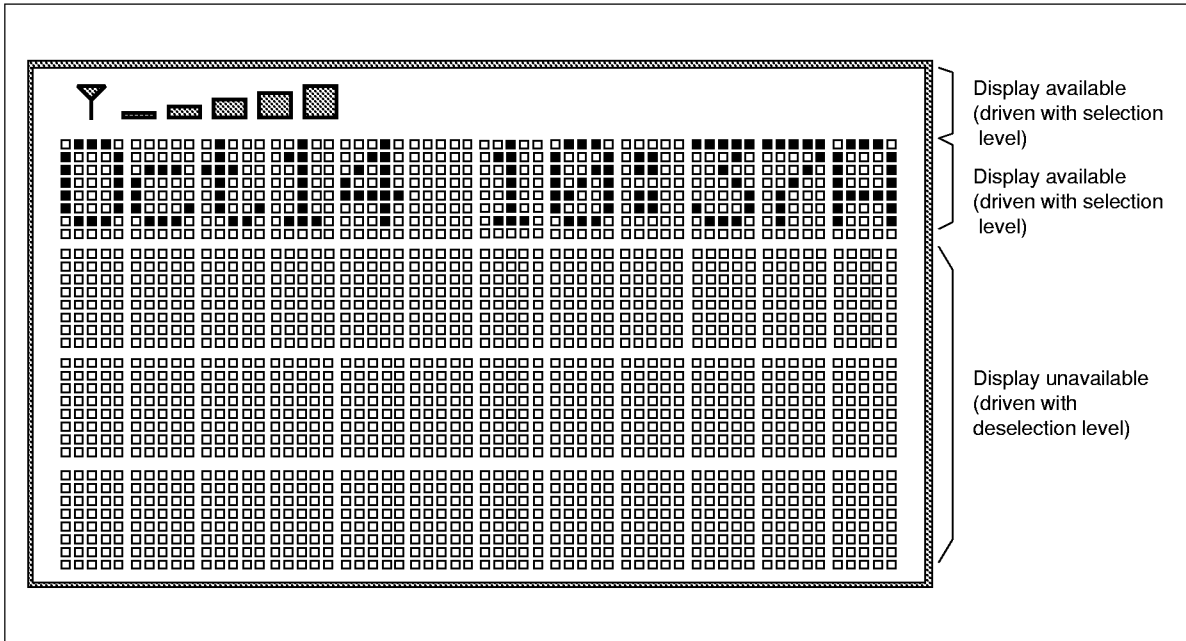

Figure 49 Example of Partially-Off Display (date and time indicated)

Sleep Mode

Setting the sleep mode bit (SLP) to 1 puts the HD66727 in the sleep mode, where the device halts all the internal display operations except for annunciator display and key scan operations, thus reducing current consumption. Specifically, character and segment displays, which are controlled by the multiplexing drive method, are completely halted. Here, all the SEG (SEG1 to SEG60) and COM (COM1 to COM34) pins output the V_{CC} level, resulting in no display. If the AMP bit is set to 0 in the sleep mode, the LCD drive power supply can be turned off, reducing the total current consumption of the LCD module.

Annunciators can be normally displayed in the sleep mode. Since they are driven at logic operating power supply voltage ($V_{CC} - AGND$), they are available even if the LCD power supply is turned off (AMP = 0). This function allows time and alarm marker indication during system standby with reduced current consumption.

During the sleep mode, no instructions can be accepted for character/segment display and neither DDRAM, CGRAM, nor SEGRAM can be accessed.

The key scan circuit operates normally in the sleep mode, thus allowing normal key scan and key scan interrupt generation. All keys can be scanned while only displaying annunciators. For details, refer to the Key Scan Control section.

Table 38 compares the functions of the sleep mode and standby mode.

Table 38 Comparison of Sleep Mode and Standby Mode

Function	Sleep Mode (SLP = 1)	Standby Mode (STB = 1)
Character display	Turned off	Turned off
Segment display	Turned off	Turned off
Annunciator display	Can be turned on	Can be turned on when an alternating signal is supplied to the EXM pin
R-C oscillation	Operates normally	Halted
Key scan	Can operate normally	Halted but IRQ* can be generated

Standby Mode

Setting the standby mode bit (STB) to 1 puts the HD66727 in the standby mode, where the device stops completely, halting all internal operations including the R-C oscillator, thus further reducing current consumption compared to that in the sleep mode. Specifically, character and segment displays, which are controlled by the multiplexing drive method, are completely halted. Here, all the SEG (SEG1 to SEG60) and COM (COM1 to COM34) pins output the V_{CC} level, resulting in no display. If the AMP bit is set to 0 in the standby mode, the LCD drive power supply can be turned off.

Annunciators can be displayed simply by supplying an approximately 40-Hz alternating signal for the LCD drive signals to the EXM pin externally. If annunciator display is unnecessary during the standby mode, the EXM pin must be fixed to the V_{CC} or GND level and the annunciator display on bit (DA) set to 0.

During the standby mode, no instructions can be accepted other than those for annunciator display, the start-oscillator instruction, and the key scan interrupt generation enable instruction. To cancel the standby mode, issue the start oscillator instruction to stabilize R-C oscillation before setting the STB bit to 0.

Although key scan is halted in the standby mode, the HD66727 can detect four key inputs connected with strobe signal KST0, thus generating the key scan interrupt (IRQ*). This means, the system can be activated from the completely inactive state. For details, refer to the Key Scan Control section.

Figure 50 shows the procedure for setting and canceling the standby mode.

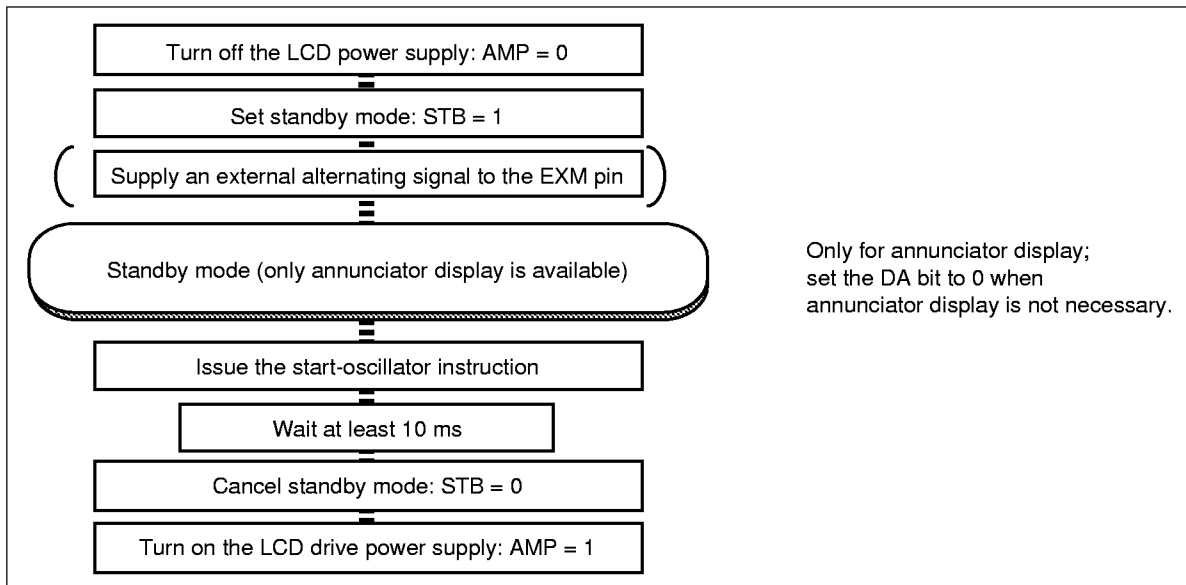

Figure 50 Procedure for Setting and Canceling Standby Mode

Absolute Maximum Ratings *

Item	Symbol	Unit	Value	Notes**
Power supply voltage (1)	V_{CC}	V	-0.3 to +7.0	1
Power supply voltage (2)	$V_{CC} - V_{EE}$	V	-0.3 to +15.0	1, 2
Input voltage	V_t	V	-0.3 to $V_{CC} + 0.3$	1
Operating temperature	T_{opr}	°C	-30 to +75	
Storage temperature	T_{stg}	°C	-55 to +110	4

Note: * If the LSI is used above these absolute maximum ratings, it may become permanently damaged. Using the LSI within the following electrical characteristic limits is strongly recommended for normal operation. If these electrical characteristic conditions are also exceeded, the LSI will malfunction and cause poor reliability.

HD66727

DC Characteristics ($V_{CC} = 2.4$ to $5.5V$, $T_a = -30$ to $+75^{\circ}C^{*3}$)

Item	Symbol	Min	Typ	Max	Unit	Test Condition	Notes
Input high voltage	V_{IH}	$0.7V_{CC}$	—	V_{CC}	V		6
Input low voltage	V_{IL}	-0.3	—	$0.15V_{CC}$	V	$V_{CC} = 2.4$ to $3.0V$	6
Input low voltage	V_{IL}	-0.3	—	0.6	V	$V_{CC} = 3.0$ to $5.5V$	6
Output high voltage (1) (SDA pin)	$VOH1$	$0.75V_{CC}$	—	—	V	$I_{OH} = -0.1$ mA	7
Output low voltage (1) (SDA pin)	$VOL1$	—	—	$0.2V_{CC}$	V	$V_{CC} = 2.4$ to $4.5V$, $I_{OL} = 0.4$ mA	5
Output low voltage (1) (SDA pin)	$VOL1$	—	—	0.4	V	$V_{CC} = 4.5$ to $5.5V$, $I_{OL} = 1.0$ mA	5
Output high voltage (2) (KST0-7, IRQ* pins)	$VOH2$	$0.7V_{CC}$	—	—	V	$-I_{OH} = 0.5$ μA , $V_{CC} = 3V$	5
Output low voltage (2) (KST0-7, IRQ* pins)	$VOL2$	—	—	$0.2V_{CC}$	V	$I_{OL} = 0.1$ mA	5
Output high voltage (3) (LED0-2 pins)	$VOH3$	$0.75V_{CC}$	—	—	V	$-I_{OH} = 0.1$ mA	5
Output low voltage (3) (LED0-2 pins)	$VOL3$	—	0.2	1.0	V	$I_{OL} = 3$ mA $V_{CC} = 3V$	5
Output high voltage (4) (PORT0-2 pins)	$VOH4$	$0.75V_{CC}$	—	—	V	$-I_{OH} = 0.1$ mA	5
Output low voltage (4) (PORT0-2 pins)	$VOL4$	—	—	$0.2V_{CC}$	V	$I_{OL} = 0.1$ mA	5
Driver ON resistance (COM pins)	R_{COM}	—	2	20	$k\Omega$	$\pm I_d = 0.05$ mA, VLCD = 4V	8
Driver ON resistance (SEG pins)	R_{SEG}	—	2	30	$k\Omega$	$\pm I_d = 0.05$ mA, VLCD = 4V	8
I/O leakage current	I_{LI}	-1	—	1	μA	$V_{in} = 0$ to V_{CC}	9
Pull-up MOS current 1 (KIN0-3 pins)	$-I_{p1}$	1	10	40	μA	$V_{CC} = 3V$, $V_{in} = 0V$	
Pull-up MOS current 2 (RESET* pins)	$-I_{p2}$	5	50	120	μA	$V_{CC} = 3V$, $V_{in} = 0V$	
Current consumption during normal operation (V_{CC} -GND)	I_{OP}	—	30	60	μA	R-C oscillation, $V_{CC} = 3V$, $f_{osc} = 160$ kHz (1/34 duty)	10, 11
Current consumption during sleep mode (V_{CC} -GND)	I_{SL}	—	25	—	μA	R-C oscillation, $V_{CC} = 3V$, $f_{osc} = 160$ kHz (1/34 duty)	10, 11
Current consumption during standby mode (V_{CC} -GND)	I_{ST}	—	0.1	5	μA	No R _i oscillation, $V_{CC} = 3V$, $T_a = 25^{\circ}C$	10, 11

Note: For the numbered notes, refer to the Electrical Characteristics Notes section following these tables.

DC Characteristics ($V_{CC} = 2.4$ to $5.5V$, $T_a = -30$ to $+75^{\circ}C^{*3}$) (cont)

Item	Symbol	Min	Typ	Max	Unit	Test Condition	Notes
LCD drive power supply current ($V_{CC}-V_{EE}$)	I_{EE}	—	25	60	μA	$V_{CC} - V_{EE} = 7V$, $f_{OSC} = 160$ kHz	11
LCD drive voltage with 1/4 bias ($V_{CC}-V_{EE}$)	VLCD1	3.0	—	13.0	V	V2-V3 short-circuited	12
LCD drive voltage with 1/6 bias ($V_{CC}-V_{EE}$)	VLCD2	3.0	—	13.0	V	V2-V3 open	12

Note: For the numbered notes, refer to the Electrical Characteristics Notes section following these tables.

Booster Characteristics

Item	Symbol	Min	Typ	Max	Unit	Test Condition	Notes
Output voltage (V5OUT2 pin)	VUP2	8.0	8.8	—	V	$V_{CC} = V_{ci} = 4.5V$, $I_o = 0.1$ mA, $C = 1$ μF , $f_{OSC} = 160$ kHz, $T_a = 25^{\circ}C$	15
Output voltage (V5OUT3 pin)	VUP3	7.0	7.9	—	V	$V_{CC} = V_{ci} = 2.7V$, $I_o = 0.1$ mA, $C = 1$ μF , $f_{OSC} = 160$ kHz, $T_a = 25^{\circ}C$	15
Input voltage	V _{ci}	1.0	—	5.0	V	$V_{ci} \leq V_{CC}$	15

Note: For the numbered notes, refer to the Electrical Characteristics Notes section following these tables.

AC Characteristics ($V_{CC} = 2.4$ to $5.5V$, $T_a = -30$ to $+75^{\circ}C^{*3}$)

Clock Characteristics

Item	Symbol	Min	Typ	Max	Unit	Test Condition	Notes
External clock frequency	f_{cp}	20	160	350	kHz		13
External clock duty ratio	Duty	45	50	55	%		13
External clock rise time	t_{rtp}	—	—	0.2	μs		13
External clock fall time	t_{fcp}	—	—	0.2	μs		13
Internal Rf oscillation frequency	t_{OSC}	120	160	200	kHz	$R_i = 150$ k Ω , $V_{CC} = 3V$	14

Note: For the numbered notes, refer to the Electrical Characteristics Notes section following these tables.

HD66727

Clock-Synchronized Serial Interface Timing

Item	Symbol	Min	Typ	Max	Unit	Test Condition
Serial clock cycle time	t_{SCYC}	1	—	20	μs	Figures 57 and 58
Serial clock high-level width	t_{SCH}	400	—	—	ns	Figures 57 and 58
Serial clock low-level width	t_{SCL}	400	—	—	ns	Figures 57 and 58
Serial clock rise/fall time	t_{scr}, t_{scf}	—	—	50	ns	Figures 57 and 58
Chip select set-up time	t_{CSU}	60	—	—	ns	Figures 57 and 58
Chip select hold time	t_{CH}	200	—	—	ns	Figures 57 and 58
Serial input data set-up time	t_{SISU}	200	—	—	ns	Figure 57
Serial input data hold time	t_{SIH}	200	—	—	ns	Figure 57
Serial output data delay time	t_{SOD}	—	—	400	ns	Figure 58
Serial output data hold time	t_{SOH}	0	—	—	ns	Figure 59

I²C bus Interface Timing

Item	Symbol	Min	Typ	Max	Unit	Test Condition
SCL clock cycle time	t_{SCL}	2	—	20	μs	Figure 59
SCL clock high-level width	t_{SCLH}	500	—	—	ns	Figure 59
SCL clock low-level width	t_{SCLL}	1000	—	—	ns	Figure 59
SCL/SDA rise/fall time	t_{sr}, t_{sf}	—	—	300	ns	Figure 59
Bus free time	t_{BUF}	140	—	—	ns	$V_{CC} = 2.4\text{--}4.5\text{V}$
Bus free time	t_{BUF}	100	—	—	ns	$V_{CC} = 4.5\text{--}5.5\text{V}$
Start hold time	t_{STAH}	500	—	—	ns	Figure 59
Retransmit start set-up time	t_{STAS}	500	—	—	ns	Figure 59
Stop set-up time	t_{STOS}	500	—	—	ns	Figure 59
SDA data set-up time	t_{SDAS}	140	—	—	ns	$V_{CC} = 2.4\text{--}4.5\text{V}$
SDA data set-up time	t_{SDAS}	100	—	—	ns	$V_{CC} = 4.5\text{--}5.5\text{V}$
SDA data hold time	t_{SDAH}	0	—	—	ns	Figure 59

Reset Timing

Item	Symbol	Min	Typ	Max	Unit	Test Condition
Reset low-level width	t_{RES}	10	—	—	ms	Figure 60

Electrical Characteristics Notes

1. All voltage values are referred to GND = 0V. If the LSI is used above the absolute maximum ratings, it may become permanently damaged. Using the LSI within the given electrical characteristic is strongly recommended to ensure normal operation. If these electrical characteristic are exceeded, the LSI may malfunction or exhibit poor reliability.
2. $V_{CC} > V1 \geq V2 \geq V3 \geq V4 \geq V5 > V_{EE}$ must be maintained.
3. For bare die products, specified at 75°C.
4. For bare die products, specified by the common die shipment specification.
5. The following four circuits are I/O pin configurations except for liquid crystal display output (Figure 51).

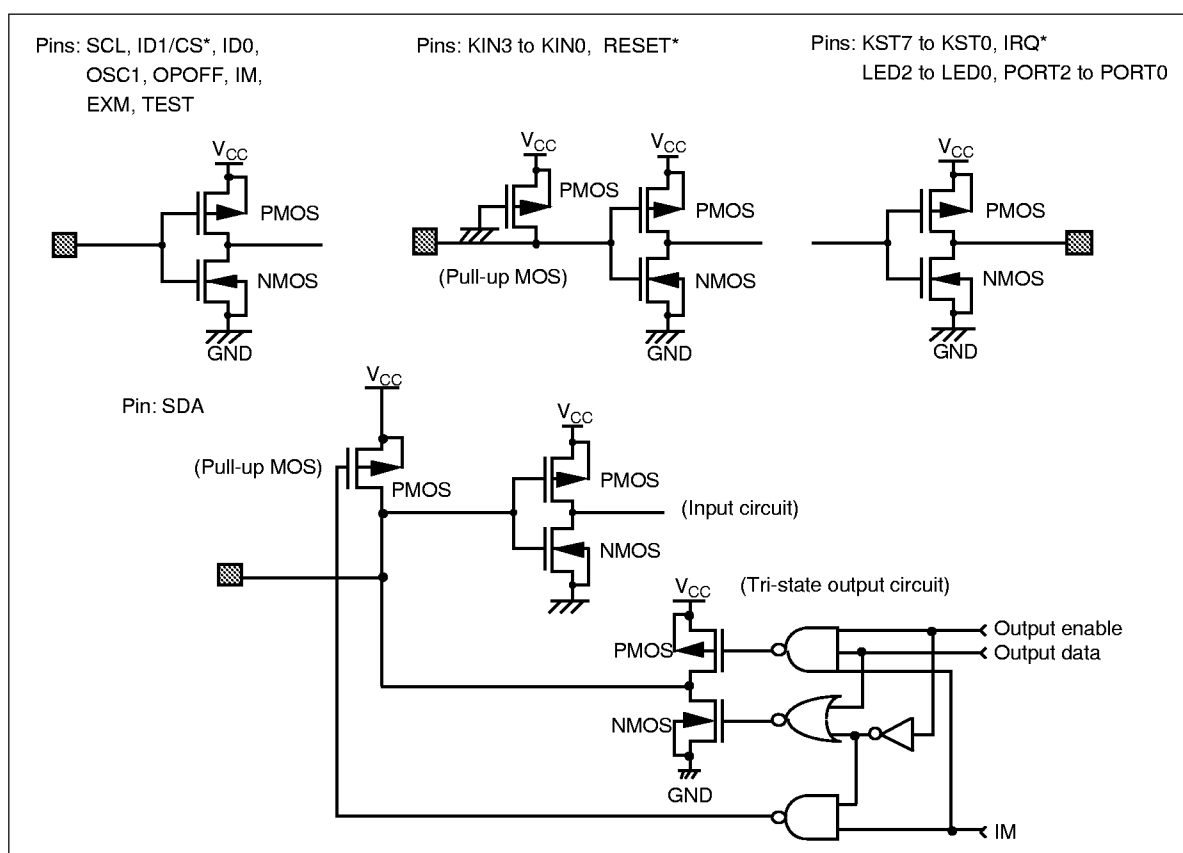

Figure 51 I/O Pin Configurations

6. The TEST pin must be grounded and the ID1 and ID0, IM, EXM, and OPOFF pins must be grounded or connected to V_{CC}.
7. Corresponds to the high output for clock-synchronized serial interface.

HD66727

8. Applies to resistor values (R_{COM}) between power supply pins V_{CC} , V1OUT, V4OUT, V5OUT and common signal pins (COM1 to COM32, COMS1, and COMS2), and resistor values (R_{SEG}) between power supply pins V_{CC} , V2OUT, V3OUT, V5OUT and segment signal pins (SEG1 to SEG60).
9. This excludes the current flowing through pull-up MOSs and output drive MOSs.
10. This excludes the current flowing through the input/output units. The input level must be fixed high or low because through current increases if the CMOS input is left floating.
11. The following shows the relationship between the operation frequency (f_{OSC}) and current consumption (I_{CC}) (Figure 52).

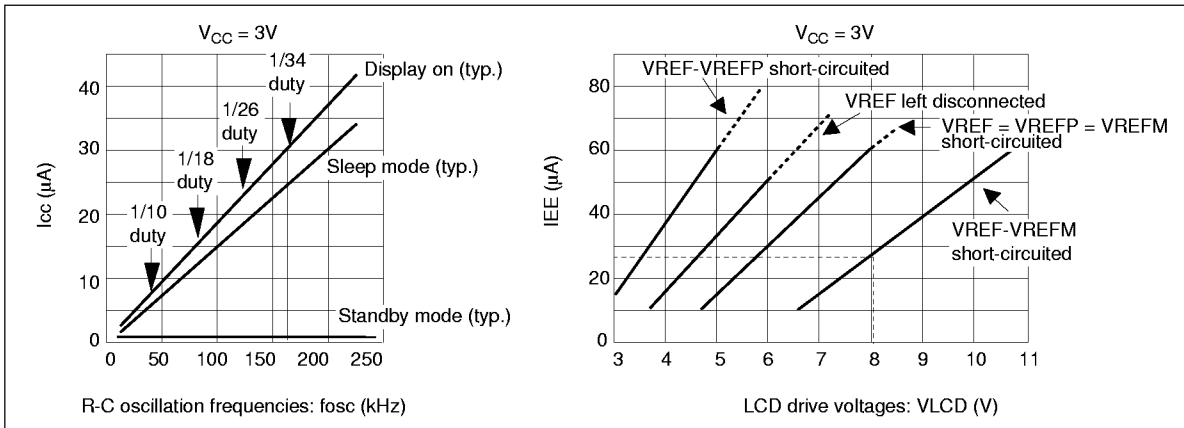

Figure 52 Relationship between the Operation Frequency and Current Consumption

12. Each COM and SEG output voltage is within $\pm 0.15V$ of the LCD voltage (V_{CC} , V1, V2, V3, V4, V5) when there is no load.
13. Applies to the external clock input (Figure 53).

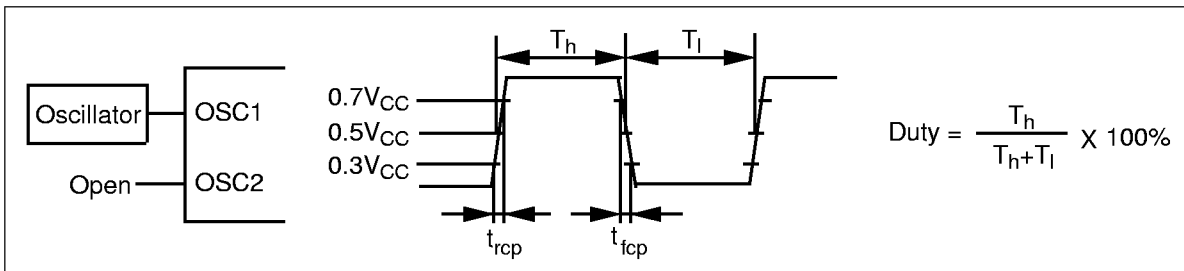

Figure 53 External Clock Supply

14. Applies to the internal oscillator operations using oscillation resistor R_f (Figure 54).

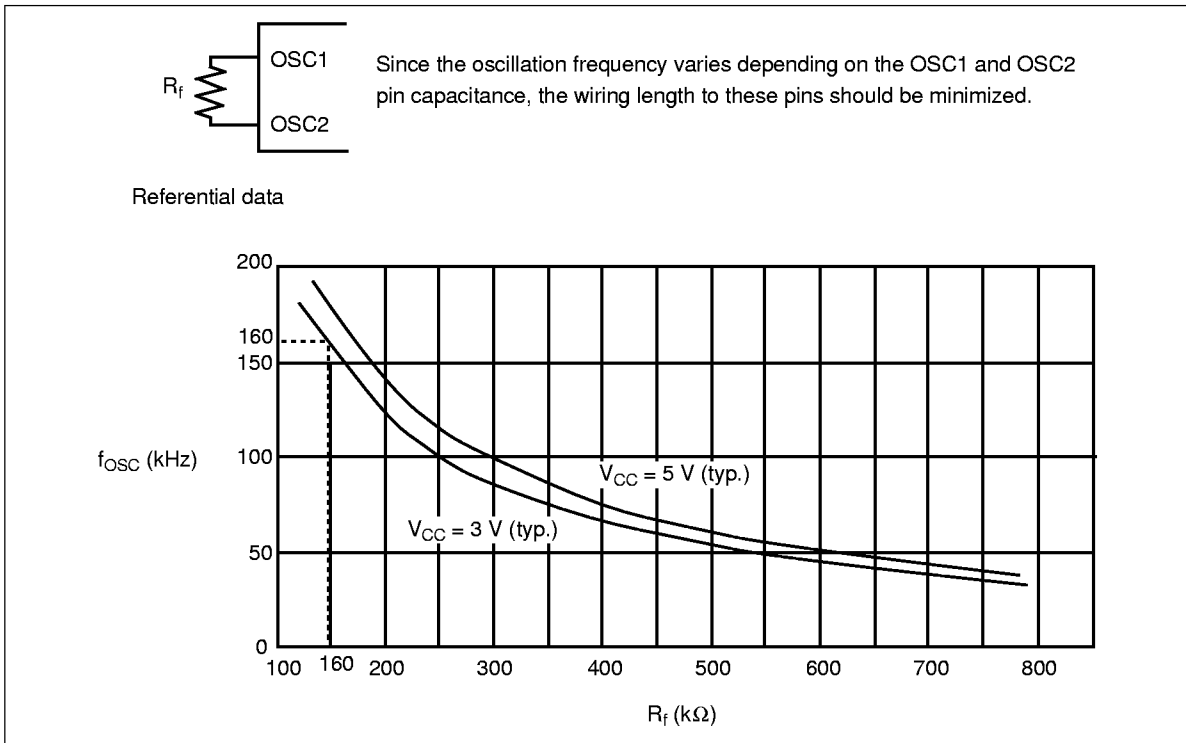

Figure 54 Internal Oscillation

15. Booster characteristics test circuits are shown in Figure 55.

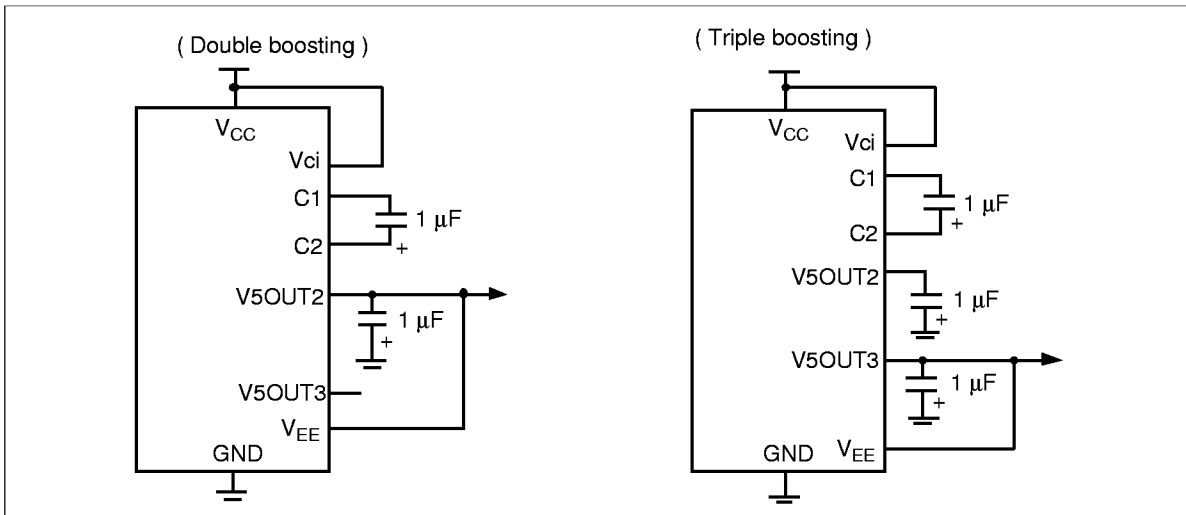
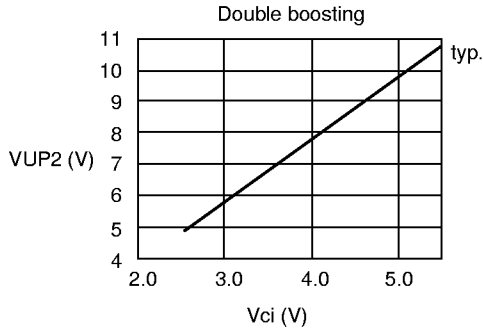

Figure 55 Booster

Referential data

$VUP2 = V_{CC} - V5OUT2$; $VUP3 = V_{CC} - V5OUT3$

(i) Relation between the obtained voltage and input voltage



$V_{ci} = V_{CC}$, $f_{cp} = 160$ kHz, $T_a = 25^\circ\text{C}$

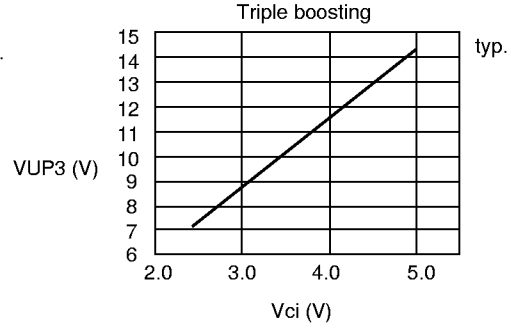

$V_{ci} = V_{CC}$, $f_{cp} = 160$ kHz, $T_a = 25^\circ\text{C}$

(ii) Relation between the obtained voltage and temperature

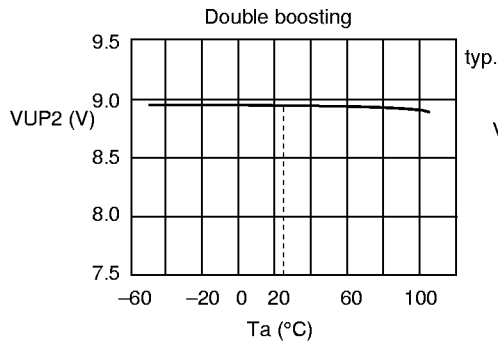

$V_{ci} = V_{CC} = 4.5$ V, $R_f = 180$ k Ω , $I_o = 0.1$ mA

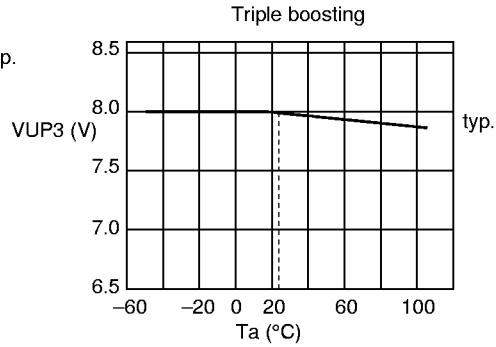

$V_{ci} = V_{CC} = 2.7$ V, $R_f = 150$ k Ω , $I_o = 0.1$ mA

(iii) Relation between the obtained voltage and capacitance

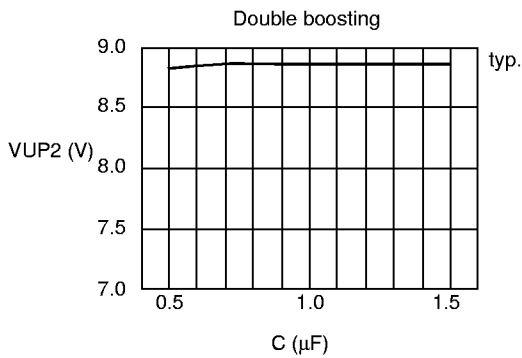

$V_{ci} = V_{CC} = 4.5$ V, $R_f = 180$ k Ω , $I_o = 0.1$ mA

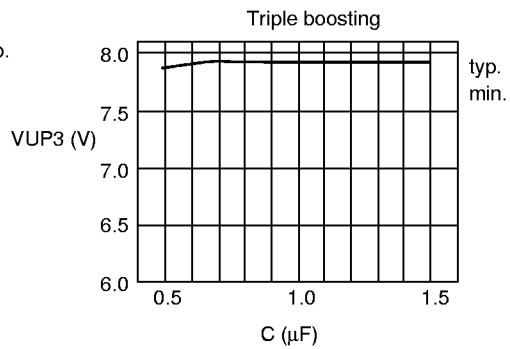

$V_{ci} = V_{CC} = 2.7$ V, $R_f = 150$ k Ω , $I_o = 0.1$ mA

Figure 55 Booster (cont)

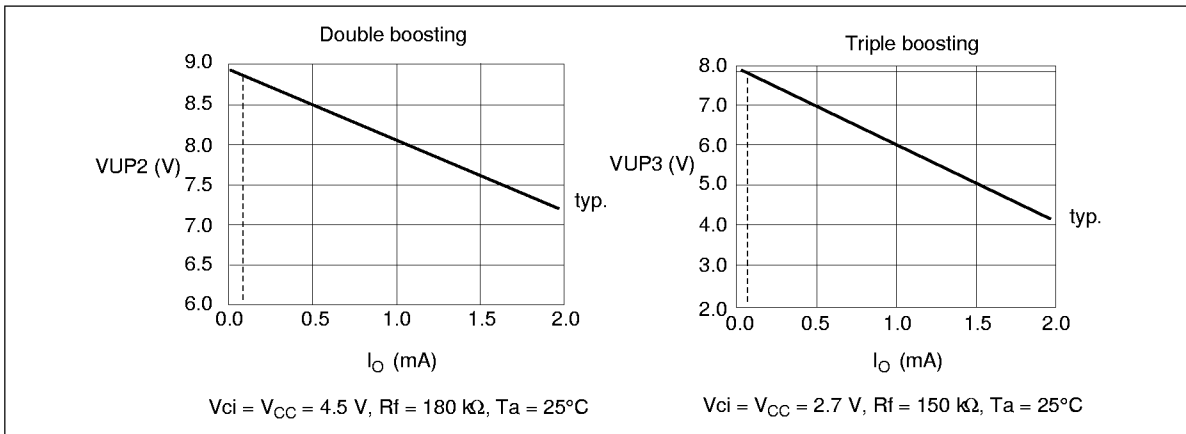

Load Circuits

AC Characteristics Test Load Circuits

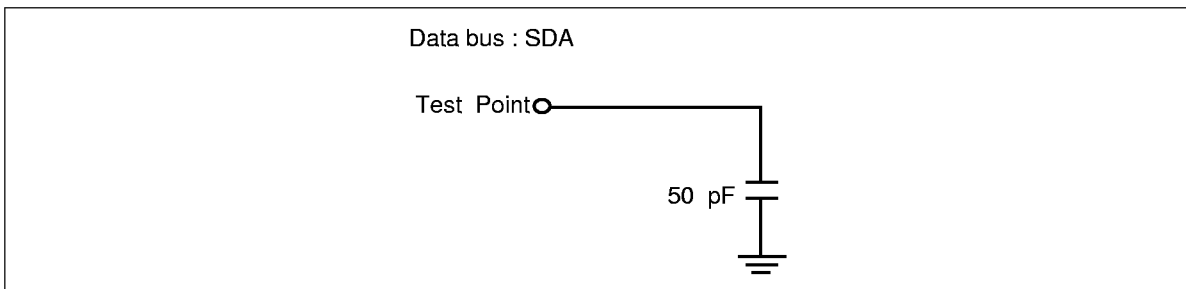

Figure 56 Load Circuit

Timing Characteristics

Clock-Synchronized Serial Interface Timing

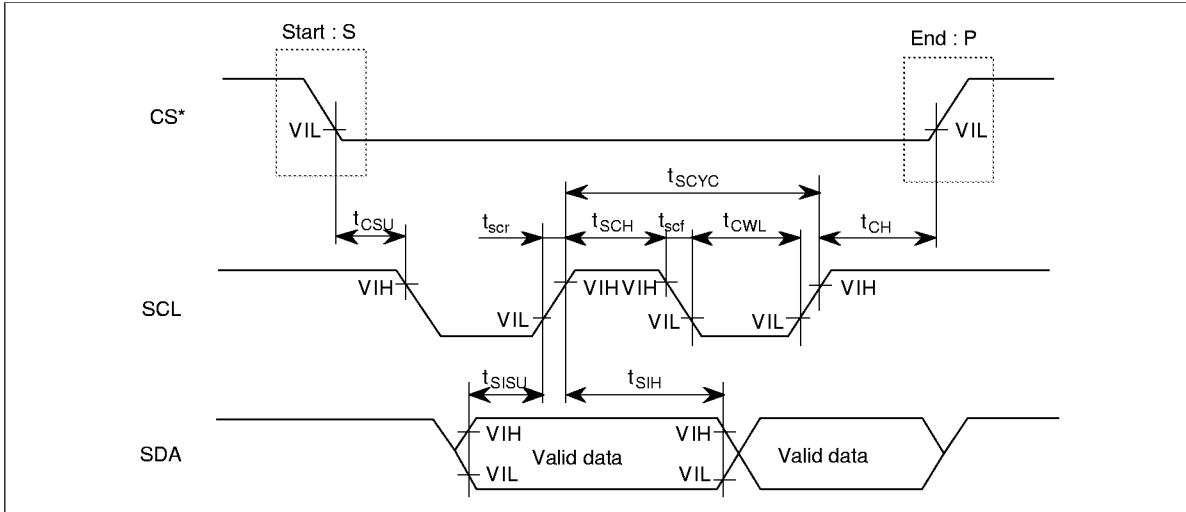

Figure 57 Clock-Synchronized Serial Interface Input Timing

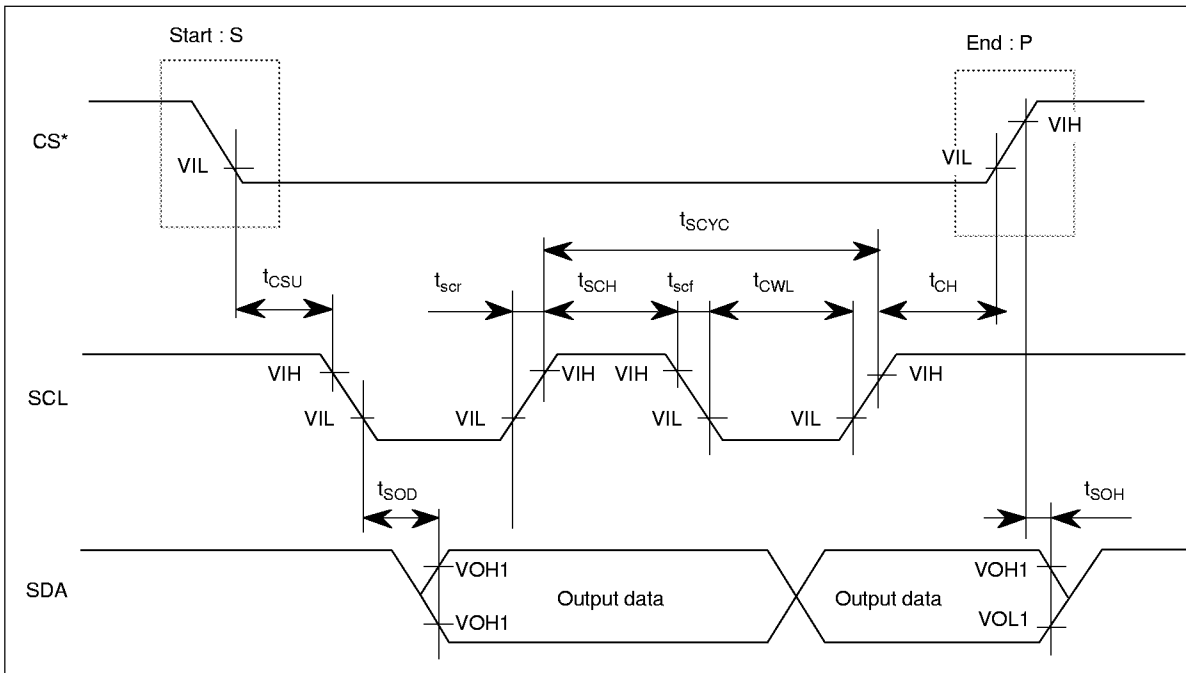

Figure 58 Clock-Synchronized Serial Interface Output Timing

I²C Bus Interface Timing

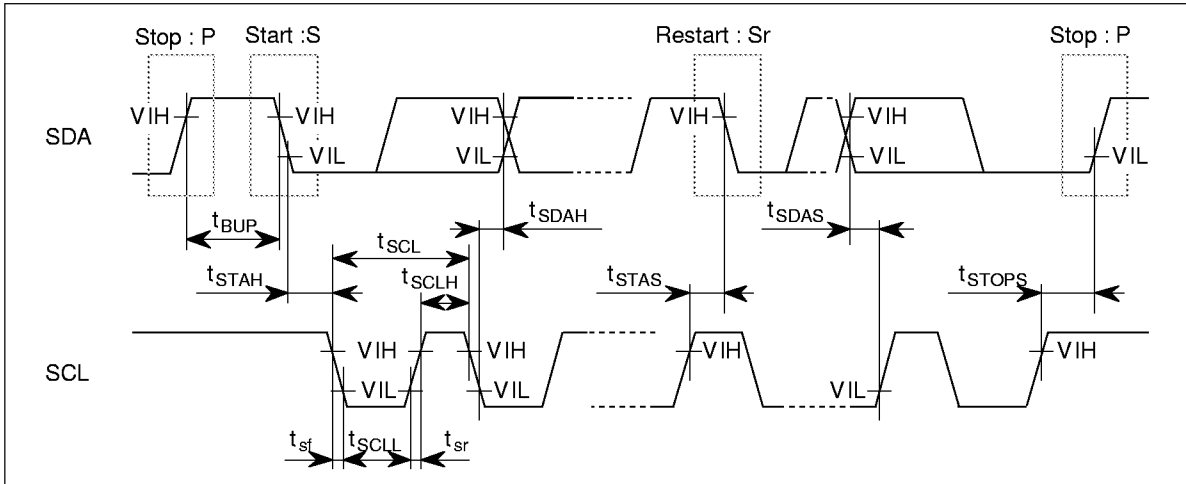

Figure 59 I²C Bus Interface Timing

Reset Timing

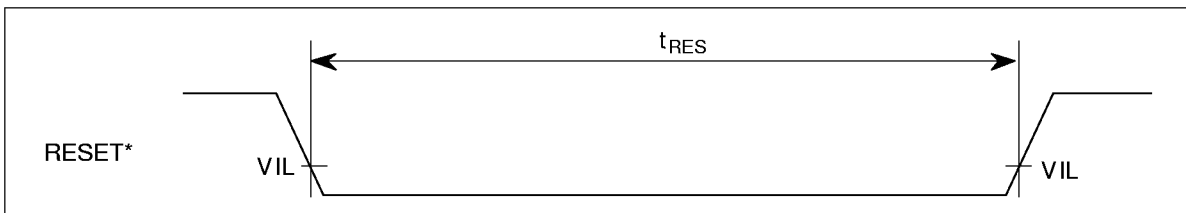

Figure 60 Reset Timing