

GENERAL DESCRIPTION

The HI-8382 and HI-8383 bus interface products are silicon gate CMOS devices designed as a line driver in accordance with the ARINC 429 bus specifications.

Inputs are provided for clocking and synchronization. These signals are AND'd with the DATA inputs to enhance system performance and allow the HI-8382 to be used in a variety of applications. Both logic and synchronization inputs feature built-in 2,000V minimum ESD input protection as well as TTL and CMOS compatibility.

The differential outputs of the HI-8382 are independently programmable to either the high speed or low speed ARINC 429 output rise and fall time specifications through the use of two external capacitors. The output voltage swing is also adjustable by the application of an external voltage to the VREF input. The HI-8382 has on-chip Zener diodes in series with a fuse to each differential output protecting the ARINC bus from an overvoltage failure. The outputs each have a series resistance of 37.5 ohms. The HI-8383 is identical to the HI-8382 except that the series resistors are 13 ohms and the overvoltage protection circuitry has been eliminated.

The HI-8382 and HI-8383 are intended for use where logic signals must be converted to ARINC 429 levels such as a user ASIC or the HI-8282 ARINC 429 Serial Transmitter/Dual Receiver or the HI-6010 ARINC 429 Transmitter/Receiver. Holt products are readily available for both industrial and military applications. Please contact the Holt Sales Department for additional information, including data sheets for the HI-8282 and HI-6010 products.

FEATURES

- Low power CMOS
- TTL and CMOS compatible inputs
- Programmable output voltage swing
- Adjustable ARINC rise and fall times
- Operates at data rates up to 100 Kbits
- Overvoltage protection
- Industrial and Military temperature ranges
- DESC SMD part number

PIN CONFIGURATION (Top View)

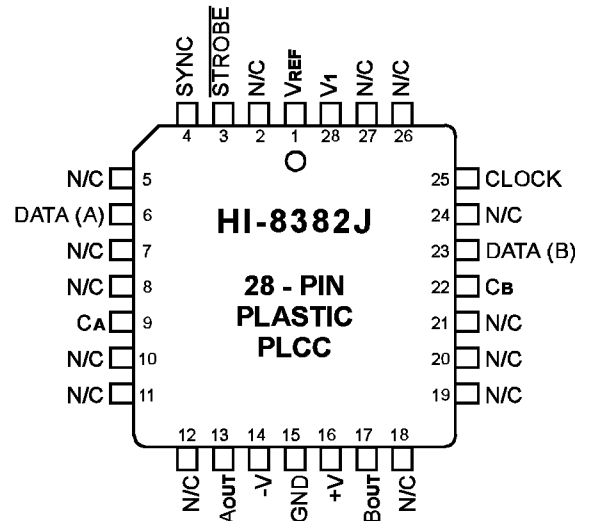

(See Page 4-31 for additional package pin configurations)

FUNCTION

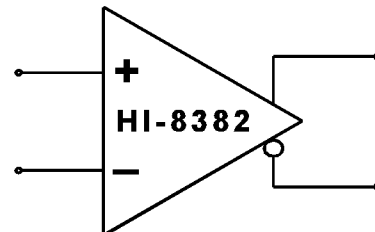

ARINC 429 DIFFERENTIAL LINE DRIVER

TRUTH TABLE

SYNC	CLOCK	DATA(A)	DATA(B)	AOUT	BOUT	COMMENTS
X	L	X	X	0V	0V	NULL
L	X	X	X	0V	0V	NULL
H	H	L	L	0V	0V	NULL
H	H	L	H	-VREF	+VREF	LOW
H	H	H	L	+VREF	-VREF	HIGH
H	H	H	H	0V	0V	NULL

FUNCTIONAL DESCRIPTION

The SYNC and CLOCK inputs establish data synchronization utilizing two AND gates, one for each data input. Each logic input, including the power enable (STROBE) input, are TTL/CMOS compatible. Besides reducing chip current drain, STROBE also floats each output. However the overvoltage fuses and diodes of the HI-8382 are not switched out.

Figure 1 illustrates a typical ARINC 429 bus application. Three power supplies are necessary to operate the HI-8382; typically +15V, -15V and +5V. The chip also works with $\pm 12V$ supplies. The +5V supply can also provide a reference voltage that determines the output voltage swing. The differential output voltage swing will equal $2V_{REF}$. If a value of V_{REF} other than +5V is needed, a separate +5V power supply is required for pin V1.

With the DATA (A) input at a logic high and DATA (B) input at a logic low, AOUT will switch to the +VREF rail and BOUT will switch to the -VREF rail (ARINC HIGH state). With both data input signals at a logic low state, the outputs will both switch to 0V (ARINC NULL state).

The driver output impedance, R_{OUT} , is nominally 75 ohms. The rise and fall times of the outputs can be calibrated through the selection of two external capacitor values that are connected to the CA and CB input pins. Typical values for high-speed operation (100KBPS) are $C_A = C_B = 75pF$ and for low-speed operation (12.5 to 14KBPS) $C_A = C_B = 500pF$.

The driver can be externally powered down by applying a logic high to the STROBE input pin. If this feature is not being used, the pin should be tied to ground.

The CA and CB pins are inputs to unity gain amplifiers. Therefore they must be allowed to swing to -5V. Provision to switch capacitors must be done with analog switches that allow voltages below their ground.

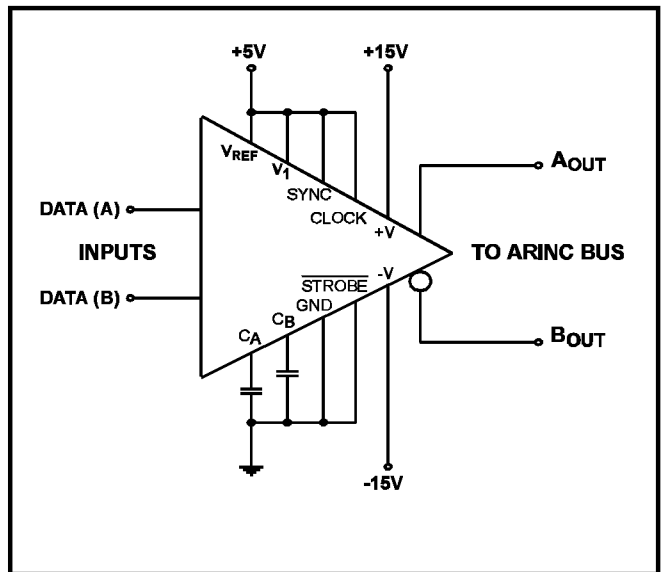

Figure 1. ARINC 429 BUS APPLICATION

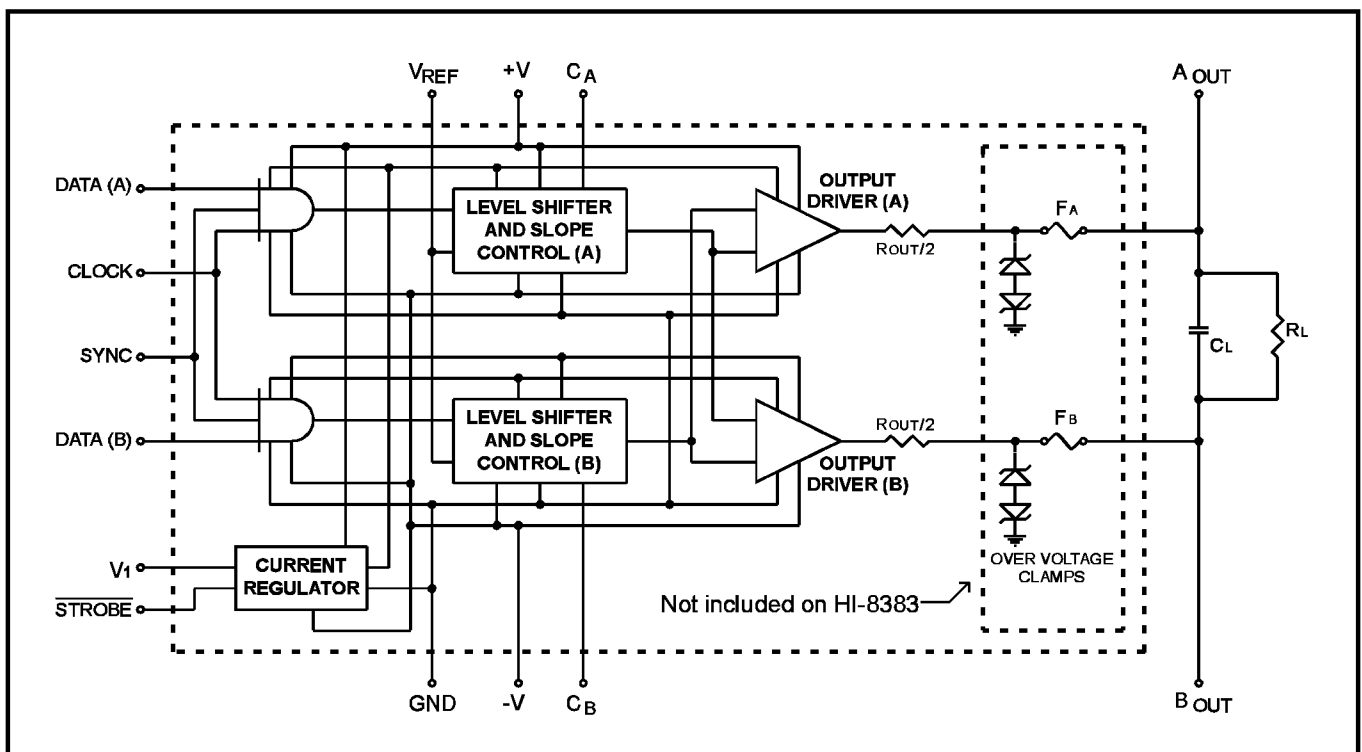

Figure 2. FUNCTIONAL BLOCK DIAGRAM

HI-8382, HI-8383

PIN DESCRIPTIONS

SYMBOL	FUNCTION	DESCRIPTION
V _{REF}	POWER	THE REFERENCE VOLTAGE USED TO DETERMINE THE OUTPUT VOLTAGE SWING
STROBE	INPUT	A LOGIC HIGH ON THIS INPUT PLACES THE DRIVER IN POWER DOWN MODE
SYNC	INPUT	SYNCHRONIZES DATA INPUTS
DATA (A)	INPUT	DATA INPUT TERMINAL A
CA	INPUT	CONNECTION FOR DATA (A) SLEW-RATE CAPACITOR
A _{OUT}	OUTPUT	ARINC OUTPUT TERMINAL A
-V	POWER	-12V to -15V
GND	POWER	0.0V
+V	POWER	+12V to +15V
B _{OUT}	OUTPUT	ARINC OUTPUT TERMINAL B
C _B	INPUT	CONNECTION FOR DATA (B) SLEW-RATE CAPACITOR
DATA (B)	INPUT	DATA INPUT TERMINAL B
CLOCK	INPUT	SYNCHRONIZES DATA INPUTS
V ₁	POWER	+5V ±5%

ABSOLUTE MAXIMUM RATINGS

All Voltages referenced to GND, T_A = Operating Temperature Range (unless otherwise specified)

PARAMETER	SYMBOL	CONDITIONS	OPERATING RANGE	MAXIMUM	UNIT
Differential Voltage	V _{DIF}	Voltage between +V and -V terminals		40	V
Supply Voltage	+V -V V ₁		+10.8 to +16.5 -10.8 to -16.5 +5 ±10%	+7	V V V
Voltage Reference	V _{REF}	For ARINC 429 For Applications other than ARINC	+5 ±5% 0 to 6	6 6	V V
Input Voltage Range	V _{IN}			≥ GND -0.3 ≤ V ₁ +0.3	V V
Output Short-Circuit Duration		See Note: 1			
Output Overvoltage Protection		See Note: 2			
Operating Temperature Range	T _A	Hi-temp & Military Industrial	-55 to +125 -40 to +85		°C °C
Storage Temperature Range	T _{STG}	Ceramic & Plastic	-65 to +150		°C
Lead Temperature		Soldering, 10 seconds		+275	°C
Junction Temperature	T _J			+175	°C
Power Dissipation	P _D	16-Pin Ceramic DIP 28-Pin Ceramic LCC 28-Pin Plastic PLCC 32-Pin CERQUAD	See Note: 3 See Note: 3 See Note: 3 See Note: 3	1.725 1.120 2.143 1.725	W W W W
Thermal Resistance, (Junction-to-Ambient)	Ø _{JA}	16-Pin Ceramic DIP 28-Pin Ceramic LCC 28-Pin Plastic PLCC 32-Pin CERQUAD		86.5 133.7 70.0 86.5	°C/W °C/W °C/W °C/W

Note 1. Heatsinking may be required for Output Short Circuit at +125°C and for 100KBPS at +125°C.

Note 2. The fuses used for Output Overvoltage Protection may be blown by the presence of a voltage at either output that is greater than ±12.0V with respect to GND. (HI-8382 only)

Note 3. Derate above +25°C, 11.5mW/°C for 16-PIN DIP and 32-PIN CERQUAD, 7.5 mW/°C for 28-PIN LCC, 14.2 mW/°C for 28-PIN PLCC

NOTE: Stresses above those listed under "Absolute Maximum Ratings" may cause permanent damage to the device. These are stress ratings only. Functional operation of the device at these or any other conditions above those indicated in the operational sections of the specifications is not implied. Exposure to absolute maximum rating conditions for extended periods may affect device reliability.

HI-8382, HI-8383

DC ELECTRICAL CHARACTERISTICS

+V = +15V, -V = -15V, V₁ = V_{REF} = +5.0V, T_A = Operating Temperature Range (unless otherwise specified).

PARAMETER	SYMBOL	CONDITION	MIN	TYP	MAX	UNITS
Supply Current +V (Operating)	ICCOP (+V)	No Load (0 - 100KBPS)			+11	mA
Supply Current -V (Operating)	ICCOP (-V)	No Load (0 - 100KBPS)	-11			mA
Supply Current V ₁ (Operating)	ICCOP (V ₁)	No Load (0 - 100KBPS)			500	μA
Supply Current V _{REF} (Operating)	ICCOP (V _{REF})	No Load (0 - 100KBPS)			500	μA
Supply Current +V (Power Down)	ICCPD (+V)	STROBE = HIGH			475	uA
Supply Current -V (Power Down)	ICCPD (-V)	STROBE = HIGH	-475			uA
Supply Current +V (During Short Circuit Test)	ISC (+V)	Short to Ground (See Note: 1)			150	mA
Supply Current -V (During Short Circuit Test)	ISC (-V)	Short to Ground (See Note: 1)	-150			mA
Output Short Circuit Current (Output High)	I _{OHSC}	Short to Ground V _{MIN} =0 (See Note: 2)			-80	mA
Output Short Circuit Current (Output Low)	I _{OLSC}	Short to Ground V _{MIN} =0 (See Note: 2)	+80			mA
Input Current (Input High)	I _{IH}				1.0	μA
Input Current (Input Low)	I _{IL}				-1.0	μA
Input Voltage High	V _{IH}		2.0			V
Input Voltage Low	V _{IL}				0.5	V
Output Voltage High (Output to Ground)	V _{OH}	No Load (0 - 100KBPS)	+V _{REF} -0.25		+V _{REF} +0.25	V
Output Voltage Low (Output to Ground)	V _{OL}	No Load (0 - 100KBPS)	-V _{REF} -0.25		-V _{REF} +0.25	V
Output Voltage Null	V _{NULL}	No Load (0-100KBPS)	-250		+250	mV
Input Capacitance	C _{IN}	See Note 1		15		pF

Note 1. Not tested, but characterized at initial device design and after major process and/or design change which affects this parameter.
 Note 2. Interchangeability of force and sense is acceptable.

AC ELECTRICAL CHARACTERISTICS

+V = +15V, -V = -15V, V₁ = V_{REF} = +5.0V, T_A = Operating Temperature Range (unless otherwise specified).

PARAMETER	SYMBOL	CONDITION	MIN	TYP	MAX	UNITS
Rise Time (AOUT, BOUT)	t _R	CA = CB = 75pF See Figure 3.	1.0		2.0	μs
Fall Time (AOUT, BOUT)	t _F	CA = CB = 75pF See Figure 3.	1.0		2.0	μs
Propagation Delay Input to Output	t _{PLH}	CA = CB = 75pF See Figure 3.			3.0	μs
Propagation Delay Input to Output	t _{PHL}	CA = CB = 75pF See Figure 3.			3.0	μs

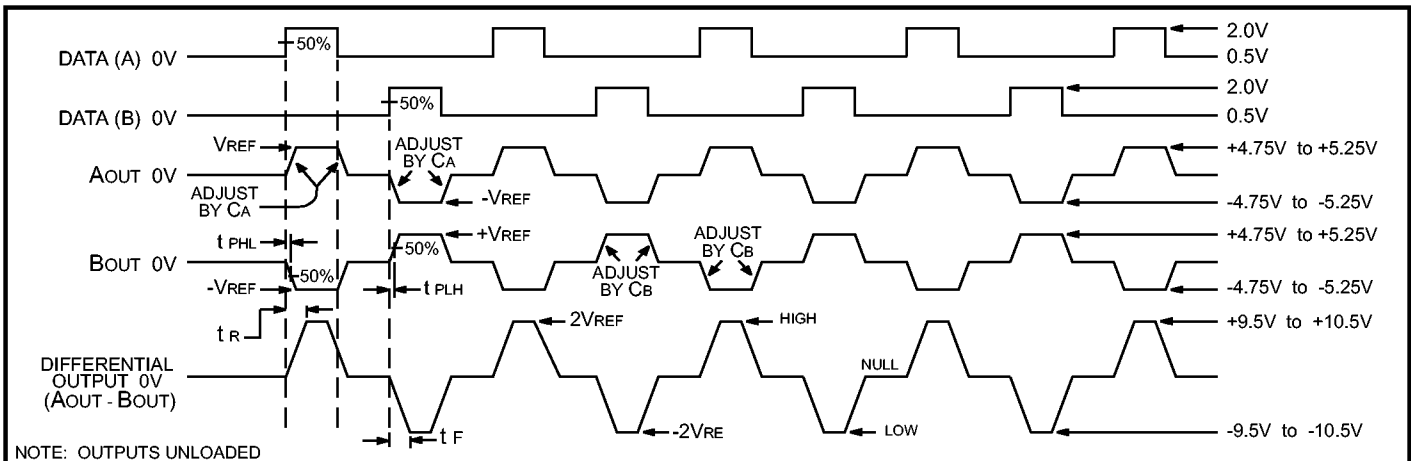
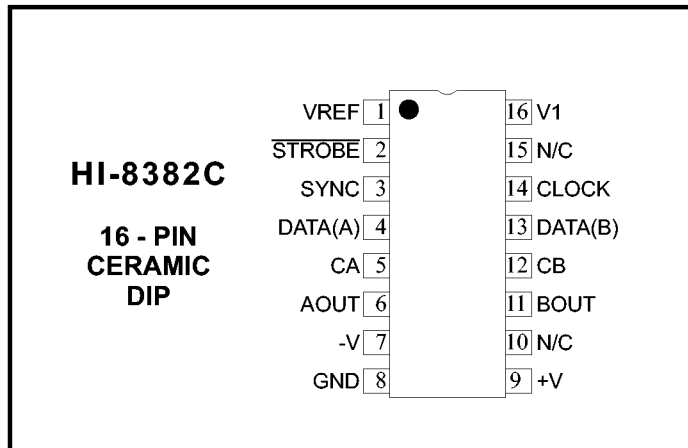
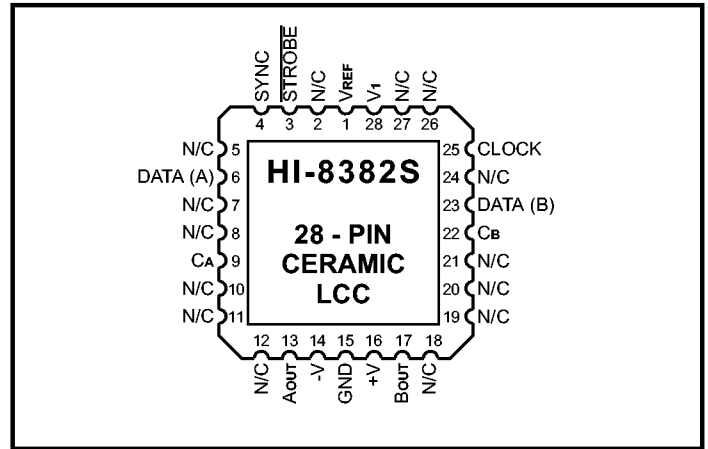
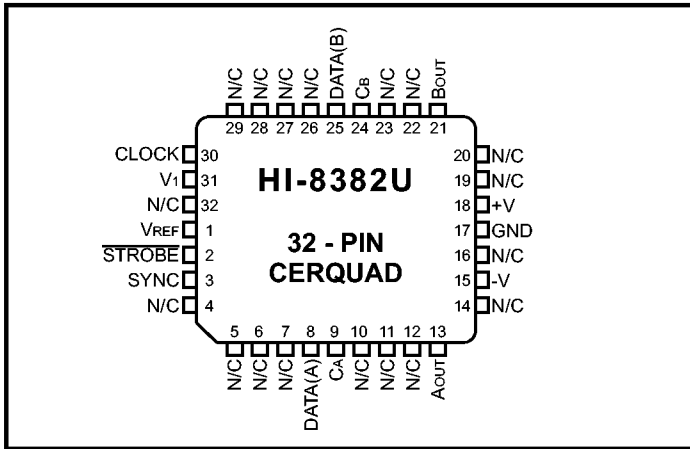

Figure 3. SWITCHING WAVEFORMS

HI-8382, HI-8383

ADDITIONAL PIN CONFIGURATIONS



ORDERING INFORMATION

HI-8383 part numbers identical except the SMD version is not available.

PART NUMBER	PACKAGE DESCRIPTION	TEMPERATURE RANGE	FLOW	BURN IN	LEAD FINISH
HI-8382C	16 PIN CERAMIC SIDE BRAZED DIP	-40°C TO +85°C	I	NO	GOLD
HI-8382CT	16 PIN CERAMIC SIDE BRAZED DIP	-55°C TO +125°C	T	NO	GOLD
HI-8382CM-01	16 PIN CERAMIC SIDE BRAZED DIP	-55°C TO +125°C	M	YES	SOLDER
HI-8382CM-03*	16 PIN CERAMIC SIDE BRAZED DIP	-55°C TO +125°C	M	YES	SOLDER
HI-8382J	28 PIN PLASTIC J-LEAD PLCC	-40°C TO +85°C	I	NO	SOLDER
HI-8382JT	28 PIN PLASTIC J-LEAD PLCC	-55°C TO +125°C	T	NO	SOLDER
HI-8382S	28 PIN CERAMIC LEADLESS CHIP CARRIER	-40°C TO +85°C	I	NO	GOLD
HI-8382ST	28 PIN CERAMIC LEADLESS CHIP CARRIER	-55°C TO +125°C	T	NO	GOLD
HI-8382SM-01	28 PIN CERAMIC LEADLESS CHIP CARRIER	-55°C TO +125°C	M	YES	SOLDER
HI-8382U	32 PIN J-LEAD CERQUAD	-40°C TO +85°C	I	NO	SOLDER
HI-8382UT	32 PIN J-LEAD CERQUAD	-55°C TO +125°C	T	NO	SOLDER

*SMD # 5962-8687901EA

16-PIN CERAMIC SIDE-BRAZED DIP

Package Type: 16C

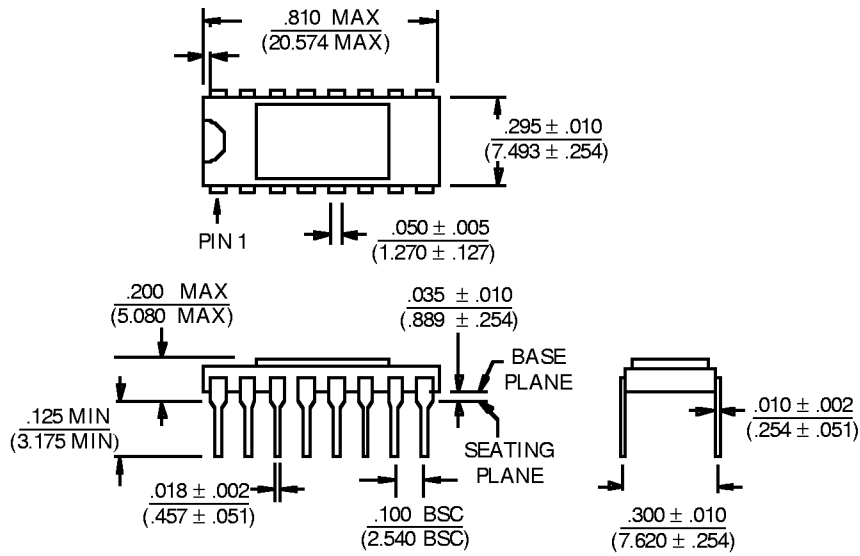

28-PIN PLASTIC PLCC

Package Type: 28J

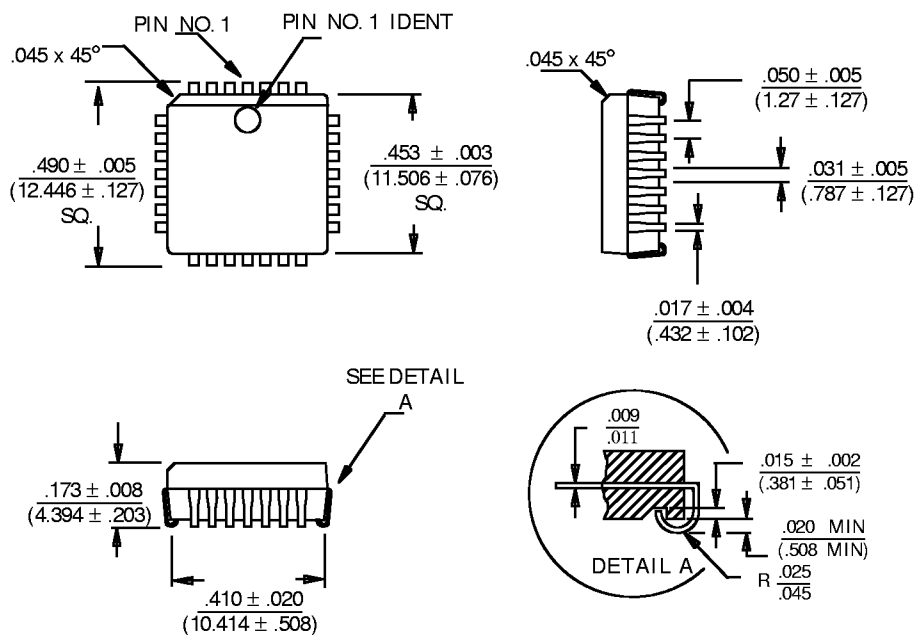

28-PIN CERAMIC LEADLESS CHIP CARRIER

Package Type: 28S

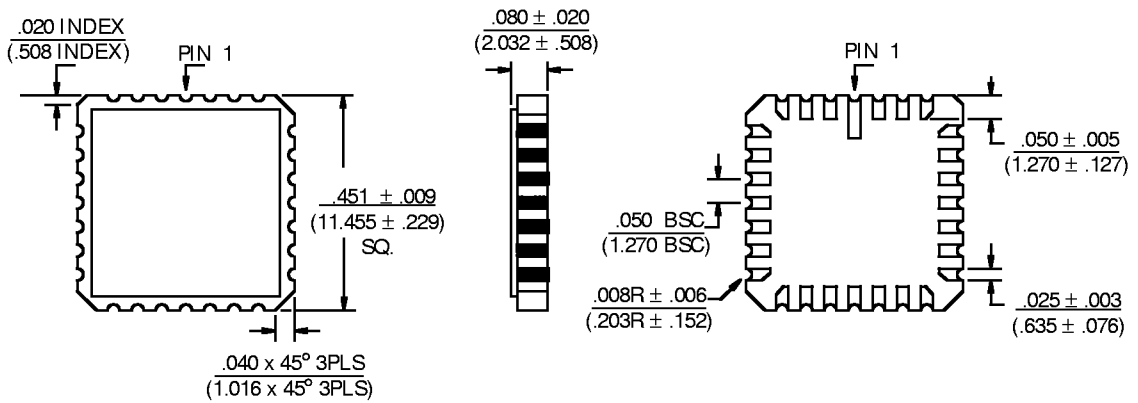

32-PIN J-LEAD CERQUAD

Package Type: 32U

