

TC4000BP DUAL 3-INPUT NOR GATE PLUS INVERTER

The TC4000BP is a combined gate which contains dual 3-input positive NOR gate plus inverter in one package.

Since all the outputs of this gate are provided with the buffers of inverters, the input/output transmission characteristics have been improved and the noise immunity has been elevated. Thus, an increase in propagation delay time caused by an increase in load capacity is kept to a minimum.

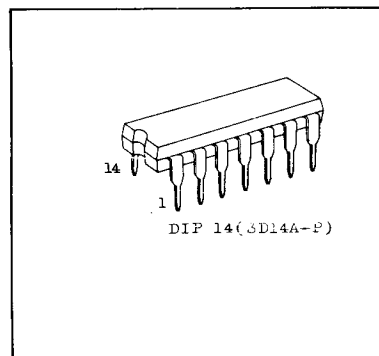

MAXIMUM RATINGS

CHARACTERISTIC	SYMBOL	RATING	UNIT
DC Supply Voltage	V _{DD}	V _{SS} -0.5 ~ V _{SS} +20	V
Input Voltage	V _{IN}	V _{SS} -0.5 ~ V _{DD} +0.5	V
Output Voltage	V _{OUT}	V _{SS} -0.5 ~ V _{DD} +0.5	V
DC Input Current	I _{IN}	±10	mA
Power Dissipation	P _D	300	mW
Operating Ambient Temperature Range	T _A	-40 ~ 85	°C
Storage Temperature Range	T _{stg}	-65 ~ 150	°C
Lead Temp./Time	T _{sol}	260°C · 10sec	

PIN ASSIGNMENT

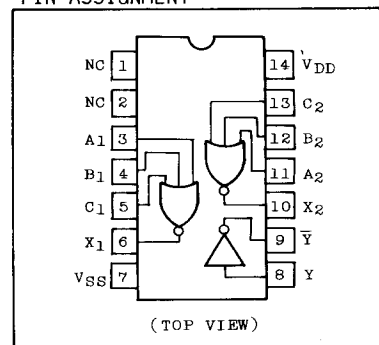

LOGIC DIAGRAM

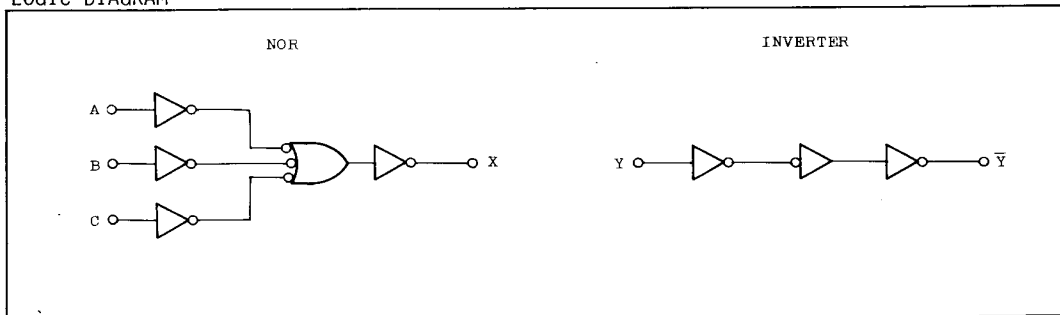

RECOMMENDED OPERATING CONDITIONS (V_{SS}=0V)

CHARACTERISTIC	SYMBOL	TEST CONDITION	MIN.	TYP.	MAX.	UNIT
DC Supply Voltage	V _{DD}		3	-	18	V
Input Voltage	V _{IN}		0	-	V _{DD}	V

STATIC ELECTRICAL CHARACTERISTICS (V_{SS}=0V)

CHARACTERISTIC	SYM-BOL	TEST CONDITION	V _{DD} (V)	-40°C		25°C			85°C		UNIT	
				MIN.	MAX.	MIN.	TYP.	MAX.	MIN.	MAX.		
High-Level Output Voltage	V _{OH}	I _{OUT} < 1μA V _{IN} =V _{SS}	5	4.95	-	4.95	5.00	-	4.95	-	V	
			10	9.95	-	9.95	10.00	-	9.95	-		
			15	14.95	-	14.95	15.00	-	14.95	-		
Low-Level Output Voltage	V _{OL}	I _{OUT} < 1μA V _{IN} =V _{SS} , V _{DD}	5	-	0.05	-	0.00	0.05	-	0.05	V	
			10	-	0.05	-	0.00	0.05	-	0.05		
			15	-	0.05	-	0.00	0.05	-	0.05		
Output High Current	I _{OH}	V _{OH} =4.6V	5	-0.61	-	-0.51	-1.0	-	-0.42	-	mA	
		V _{OH} =2.5V	5	-2.5	-	-2.1	-4.0	-	-1.7	-		
		V _{OH} =9.5V	10	-1.5	-	-1.3	-2.2	-	-1.1	-		
		V _{OH} =13.5V	15	-4.0	-	-3.4	-9.0	-	-2.8	-		
		V _{IN} =V _{SS}										
Output Low Current	I _{OL}	V _{OL} =0.4V	5	0.61	-	0.51	1.5	-	0.42	-	mA	
		V _{OL} =0.5V	10	1.5	-	1.3	3.8	-	1.1	-		
		V _{OL} =1.5V	15	4.0	-	3.4	15.0	-	2.8	-		
		V _{IN} =V _{SS} , V _{DD}										
Input High Voltage	V _{IH}	V _{OUT} =0.5V, 4.5V	5	3.5	-	3.5	2.75	-	3.5	-	V	
		V _{OUT} =1.0V, 9.0V	10	7.0	-	7.0	5.5	-	7.0	-		
		V _{OUT} =1.5V, 13.5V	15	11.0	-	11.0	8.25	-	11.0	-		
		I _{OUT} < 1μA										
Input Low Voltage	V _{IL}	V _{OUT} =0.5V, 4.5V	5	-	1.5	-	2.25	1.5	-	1.5	V	
		V _{OUT} =1.0V, 9.0V	10	-	3.0	-	4.5	3.0	-	3.0		
		V _{OUT} =1.5V, 13.5V	15	-	4.0	-	6.75	4.0	-	4.0		
		I _{OUT} < 1μA										
Input Current	"H" Level	I _{IH}	V _{IH} =18V	18	-	0.1	-	10 ⁻⁵	0.1	-	1.0	μA
	"L" Level	I _{IL}	V _{IL} =0V	18	-	-0.1	-	-10 ⁻⁵	-0.1	-	-1.0	
Quiescent Device Current	I _{DD}	V _{IN} =V _{SS} , V _{DD} *	5	-	0.25	-	0.001	0.25	-	7.5	μA	
			10	-	0.5	-	0.001	0.5	-	15		
			15	-	1.0	-	0.002	1.0	-	30		

* All valid input combinations.

DYNAMIC ELECTRICAL CHARACTERISTICS (Ta=25°C, VSS=0V, CL=50pF)

CHARACTERISTIC		SYMBOL	TEST CONDITION	VDD (V)	MIN.	TYP.	MAX.	UNIT
Output Transition Time (Low to High)	t _{TLH}			5	-	80	200	ns
				10	-	50	100	
				15	-	40	80	
Output Transition Time (High to Low)	t _{THL}			5	-	80	200	ns
				10	-	50	100	
				15	-	40	80	
INVERTER	Propagation Delay Time (Low to High)	t _{pLH}		5	-	90	180	ns
				10	-	50	100	
				15	-	40	80	
	Propagation Delay Time (High to Low)	t _{pHL}		5	-	90	180	
				10	-	50	100	
				15	-	40	80	
NOR	Propagation Delay Time (Low to High)	t _{pLH}		5	-	100	200	ns
				10	-	50	100	
				15	-	40	80	
	Propagation Delay Time (High to Low)	t _{pHL}		5	-	100	200	
				10	-	50	100	
				15	-	40	80	
Input Capacitance		C _{IN}			-	5	7.5	pF

CIRCUITS AND WAVEFORM FOR MEASUREMENT OF DYNAMIC CHARACTERISTICS

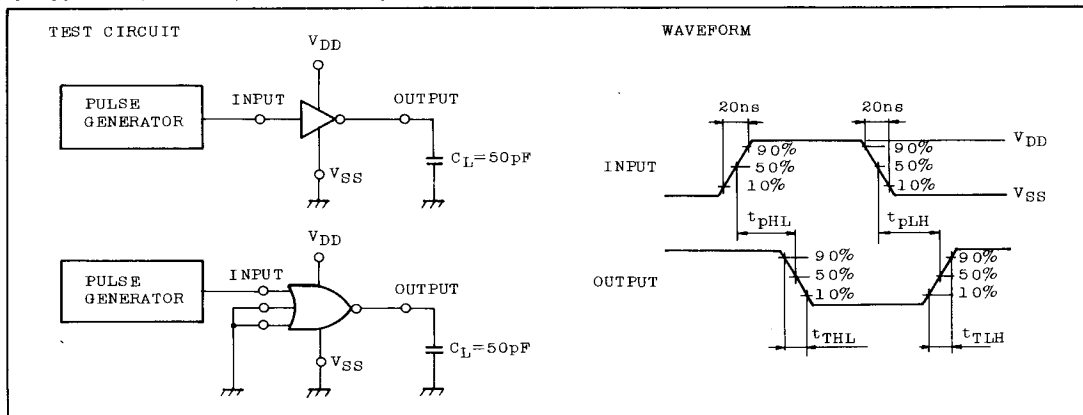

OPERATING SUPPLY CURRENT TEST CIRCUIT

