

TC5012BP/BF

C²MOS DIGITAL INTEGRATED CIRCUIT
SILICON MONOLITHIC

TC5012BP/TC5012BF HEX NON-INVERTING 3-STATE BUFFER

TC5012BP/BF contains six circuits of non-inverting buffers having three state output. Since DISABLE inputs to disable the outputs are provided separately, one common for four circuits and another common for other two circuits, this is suitable for controlling four bit data lines. Large output current enables to directly control one TTL input.

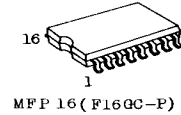
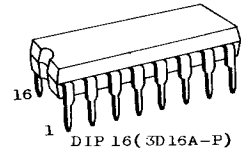

ABSOLUTE MAXIMUM RATINGS

CHARACTERISTIC	SYMBOL	RATING	UNIT
DC Supply Voltage	V _{DD}	V _{SS} - 0.5 ~ V _{SS} + 20	V
Input Voltage	V _{IN}	V _{SS} - 0.5 ~ V _{DD} + 0.5	V
Output Voltage	V _{OUT}	V _{SS} - 0.5 ~ V _{DD} + 0.5	V
DC Input Current	I _{IN}	±10	mA
Power Dissipation	PD	300 (DIP)/180 (MFP)	mW
Operating Temperature Range	T _A	-40 ~ 85	°C
Storage Temperature Range	T _{stg}	-65 ~ 150	°C
Lead Temp./Time	T _{sol}	260°C · 10 sec	

PIN ASSIGNMENT

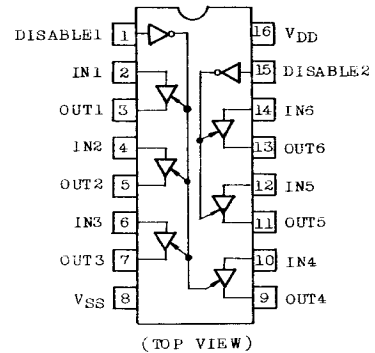

CIRCUIT DIAGRAM

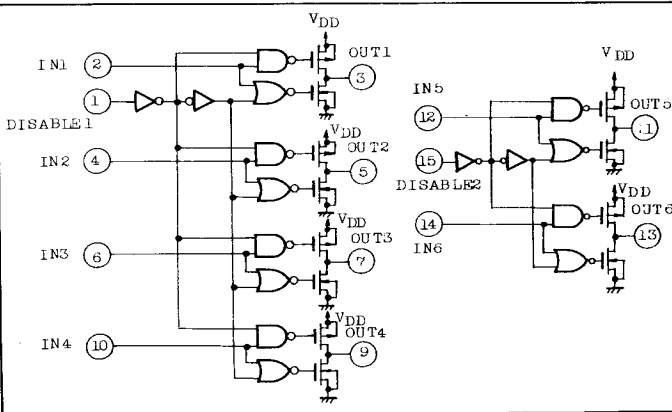

TRUTH TABLE

DISABLE INPUT	INPUT	OUTPUT
L	L	L
L	H	H
H	*	HZ

* : DON'T CARE

HZ : HIGH IMPEDANCE

RECOMMENDED OPERATING CONDITIONS (V_{SS}=0V)

CHARACTERISTIC	SYMBOL	MIN.	TYP.	MAX.	UNITS
DC Supply Voltage	V _{DD}	3	-	18	V
Input Voltage	V _{IN}	0	-	V _{DD}	V

STATIC ELECTRICAL CHARACTERISTICS (V_{SS}=0V)

CHARACTERISTIC	SYMBOL	TEST CONDITION	V _{DD} (V)	-40°C		25°C			85°C		UNITS	
				MIN.	MAX.	MIN.	TYP.	MAX.	MIN.	MAX.		
High-Level Output Voltage	V _{OH}	I _{OUT} < 1μA V _{IN} =V _{SS} , V _{DD}	5	4.95	-	4.95	5.00	-	4.95	-	V	
			10	9.95	-	9.95	10.00	-	9.95	-		
			15	14.95	-	14.95	15.00	-	14.95	-		
Low-Level Output Voltage	V _{OL}	I _{OUT} < 1μA V _{IN} =V _{SS} , V _{DD}	5	-	0.05	-	0.00	0.05	-	0.05	V	
			10	-	0.05	-	0.00	0.05	-	0.05		
			15	-	0.05	-	0.00	0.05	-	0.05		
Output High Current	I _{OH}	V _{OH} =4.6V V _{OH} =2.5V V _{OH} =9.5V V _{OH} =13.5V V _{IN} =V _{SS} , V _{DD}	5	-	-	-	-	-	-	-	mA	
			5	-1.4	-	-1.25	-	-1.0	-			
			10	-1.4	-	-1.25	-	-3.0	-			
			15	-4.0	-	-3.75	-	-3.0	-			
Output Low Current	I _{OL}	V _{OL} =0.4V V _{OL} =0.5V V _{OL} =1.5V V _{IN} =V _{SS} , V _{DD}	5	3.5	-	3.2	-	2.5	-	-	mA	
			10	6.0	-	5.0	-	3.6	-			
			15	26.0	-	24.0	-	18.0	-			
			15	26.0	-	24.0	-	18.0	-			
Input High Voltage	V _{IH}	V _{OUT} =0.5V, 4.5V V _{OUT} =1.0V, 9.0V V _{OUT} =1.5V, 13.5V I _{OUT} < 1μA	5	3.5	-	3.5	2.75	-	3.5	-	V	
			10	7.0	-	7.0	5.5	-	7.0	-		
			15	11.0	-	11.0	8.25	-	11.0	-		
			15	11.0	-	11.0	8.25	-	11.0	-		
Input Low Voltage	V _{IL}	V _{OUT} =0.5V, 4.5V V _{OUT} =1.0V, 9.0V V _{OUT} =1.5V, 13.5V I _{OUT} < 1μA	5	-	1.5	-	2.25	1.5	-	1.5	V	
			10	-	3.0	-	4.5	3.0	-	3.0		
			15	-	4.0	-	6.75	4.0	-	4.0		
			15	-	4.0	-	6.75	4.0	-	4.0		
Input Current	"H" Level	I _{IH}	V _{IH} =18V	18	-	0.3	-	10 ⁻⁵	0.3	-	1.0	μA
	"L" Level	I _{IL}	V _{IL} =0V	18	-	-0.3	-	-10 ⁻⁵	-0.3	-	-1.0	
3-State Output Leakage Current	"H" Level	I _{DH}	V _{OUT} =18V	18	-	0.5	-	10 ⁻⁴	0.5	-	30	μA
	"L" Level	I _{DL}	V _{OUT} =0V	18	-	-0.5	-	-10 ⁻⁴	-0.5	-	-30	
Quiescent Device Current	I _{DD}	V _{IN} =V _{SS} , V _{DD} *	5	-	4.0	-	0.002	4.0	-	30	μA	
			10	-	8.0	-	0.004	8.0	-	60		
			15	-	16.0	-	0.008	16.0	-	120		

* All valid input combinations.

TC5012BP/BF

DYNAMIC ELECTRICAL CHARACTERISTICS (Ta=25°C, V_{SS}=0V, C_L=50pF)

CHARACTERISTIC	SYMBOL	TEST CONDITION	V _{DD} (V)	MIN.	TYP.	MAX.	UNITS
Output Transition Time (Low to High)	t _{TLH}		5	-	130	400	ns
			10	-	65	200	
			15	-	50	100	
Output Transition Time (High to Low)	t _{THL}		5	-	70	200	
			10	-	40	100	
			15	-	35	80	
Propagation Delay Time (IN - OUT)	t _{pLH}		5	-	320	430	
			10	-	150	220	
			15	-	110	200	
Propagation Delay Time (IN - OUT)	t _{pHL}		5	-	280	380	
			10	-	130	220	
			15	-	100	200	
Three State Disable Time (DISABLE - OUT)	t _{pHZ}	R _L =1kΩ	5	-	320	500	
			10	-	280	450	
			15	-	250	400	
Three State Disable Time (DISABLE - OUT)	t _{pLZ}	R _L =1kΩ	5	-	420	600	
			10	-	320	500	
			15	-	270	450	
Three State Disable Time (DISABLE - OUT)	t _{pZH}	R _L =1kΩ	5	-	280	400	
			10	-	140	200	
			15	-	120	180	
Three State Disable Time (DISABLE - OUT)	t _{pZL}	R _L =1kΩ	5	-	300	450	
			10	-	150	225	
			15	-	130	200	
Input Capacitance	C _{IN}			-	7.5	15	pF

WAVEFORM FOR MEASUREMENT OF DYNAMIC CHARACTERISTICS

