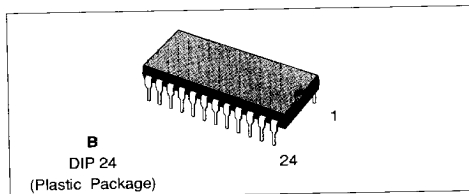

**MK6116, MKI6116, MK6116L, MKI6116L (N/S) - 15/20/25  
 2 K X 8 CMOS STATIC RAM**

- BYTEWYDE™ 2K x 8 CMOS STATIC RAM.
- +5 VOLT ONLY WRITE/READ.
- 24-PIN 600 MIL PLASTIC DIP, JEDEC PINOUT  
28-PIN 330 MIL SOIC.
- EQUAL WRITE AND READ CYCLE TIMES.
- HIGH PERFORMANCE WITH LOW CMOS  
STANDBY POWER.

**DESCRIPTION**

The MK6116 is a 16,384-bit CMOS Static RAM, organized as 2K x 8 using SGS-THOMSON Microelectronics' advanced HCMOS process technology. This device is directly compatible with the popular 24-pin, three-wire handshake, 16K static CMOS RAM. All inputs and outputs are TTL compatible using a single 5V supply. The MK6116 provides full static operation, requiring no clocks or refresh operations, and has equal access and cycle times. Additionally, whenever E (Chip Enable) goes high, the device will maintain a reduced power standby mode until E again goes active low. (Refer to the MK6116 Truth Table.)

**PIN NAMES**

A <sub>0</sub> -A <sub>10</sub>	ADDRESS INPUTS
DQ <sub>0</sub> - DQ <sub>7</sub>	DATA I/O
$\bar{E}$	CHIP ENABLE
$\bar{G}$	OUTPUT ENABLE
$\bar{W}$	WRITE ENABLE
V <sub>CC</sub> , V <sub>SS</sub>	+5V, GND

**PIN CONNECTION**

FIGURE 1 : BLOCK DIAGRAM



**MK6116 TRUTH TABLE**

$\bar{E}$	$\bar{G}$	$\bar{W}$	MODE	DQ	POWER
$V_{IH}$	X	X	deselect	High Z	Standby
$V_{IL}$	X	$V_{IL}$	Write	$D_{IN}$	Active
$V_{IL}$	$V_{IL}$	$V_{IH}$	Read	$D_{OUT}$	Active
$V_{IL}$	$V_{IH}$	$V_{IH}$	Read	High Z	Active

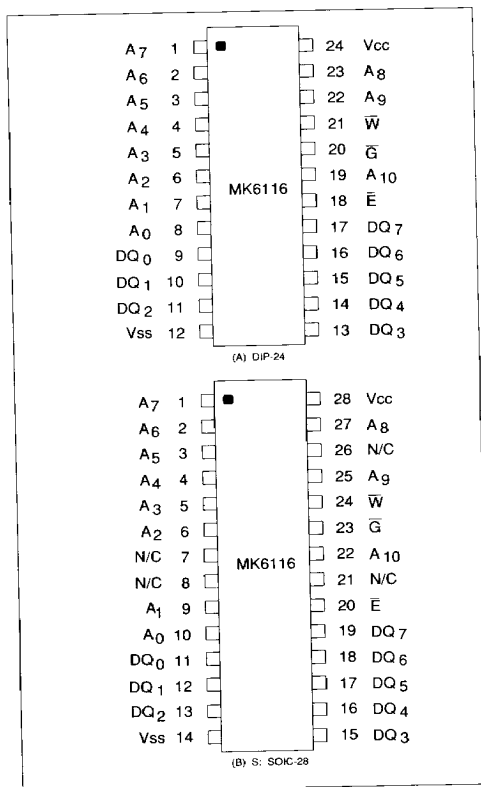
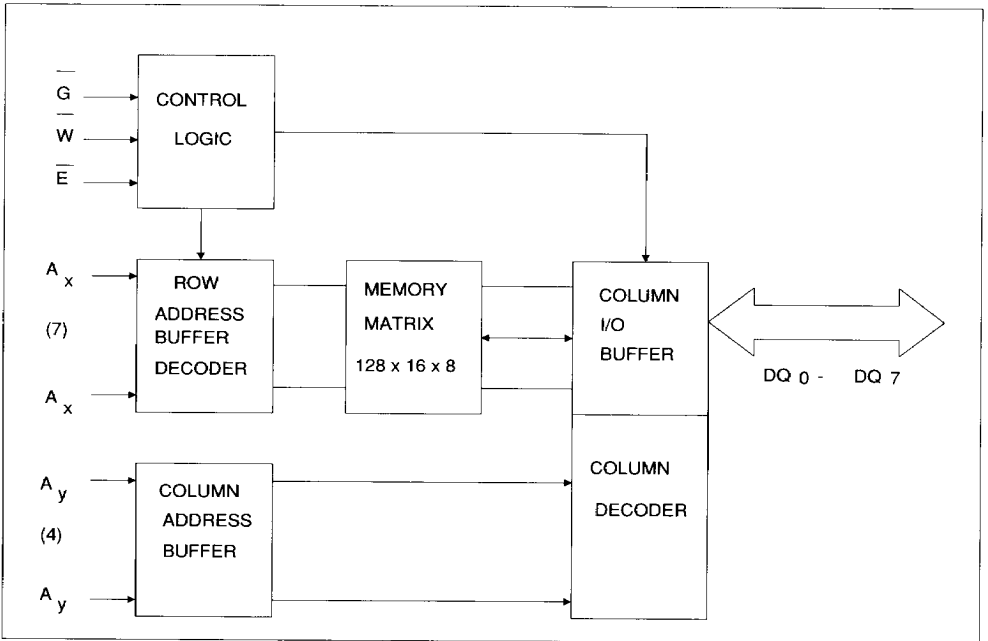
**READ MODE**

The MK6116 is in the read mode whenever  $\bar{W}$  (Write Enable) is high and  $\bar{E}$  (Chip Enable) is low, providing a ripple-through access of data from eight of 16,384 locations in the static storage array. Thus, the unique address specified by the 11 Address Inputs ( $A_0-A_{10}$ ) defines which one of 2048 bytes of data is to be accessed.

Valid data will be available at the eight Data Outputs Drivers ( $DQ_0-DQ_7$ ) within  $t_{AVQV}$  after the last ad-

dress input signal is stable, provided that the  $\bar{E}$  and  $\bar{G}$  (Out-put Enable) access times are satisfied. If  $\bar{E}$  or  $\bar{G}$  access times are not met, data access will be measured from the limiting parameter ( $t_{ELQV}$  or  $t_{GLQV}$ ) rather than address. The state of the eight Data I/O signals is controlled by the  $\bar{E}$  and  $\bar{G}$  input signals. Data Out may be indeterminate between  $t_{AXQX}$  and  $t_{AVQV}$ , but data will always be valid at  $t_{AVQV}$ .



**WRITE MODE**

The MK6116 is in the Write Mode of operation whenever W and E are active low (G is a don't care as noted in the Truth Table). The latter occurring falling edge of either W or E will determine the start of the write cycle. Therefore, address setup time and write or chip enable pulse width are referenced to the latter occurring edge of W or E. The write cycle can be terminated by either earlier rising edge of W or E. The addresses must be held valid

throughout the cycle.  $\bar{W}$  must return to the high logic state for a minimum write recovery time designated as  $t_{WHWL}$  between write cycles. Addresses must remain valid for  $t_{WHAX}$  at the termination of the write cycle. The same principles apply for an E controlled write cycle.

If the output bus has been enabled ( $\bar{E}$  and  $\bar{G}$  active low), then W will disable the outputs within  $t_{WLOZ}$  from its falling edge; however, care must be taken to avoid a potential bus contention. Data-In must be valid  $t_{DVWH}$  or  $t_{DVEH}$  prior to the earlier rising

**AC ELECTRICAL CHARACTERISTICS (WRITE CYCLE)**

{ $0^{\circ}\text{C} \leq T_A \leq +70^{\circ}\text{C}$  (MK6116/L),  $-40^{\circ}\text{C} \leq T_A \leq +105^{\circ}\text{C}$  (MKI6116/L),  $V_{CC}=5.0 \pm 10\%$ }

ALT. SYMBOL	SDT. SYMBOL	PARAMETER	MK6116 - 15 MKI6116 - 15 MK6116L-15 MKI6116L-15		MK6116 - 20 MKI6116 - 20 MK6116L-20 MKI6116L-20		MK6116 - 25 MKI6116 - 25 MKL6116-25		UNITS	NOTES
			MIN	MAX	MIN	MAX	MIN	MAX		
$t_{WC}$	$t_{AVAV}$	Write Cycle Time	150		200		250		ns	
$t_{AS}$	$t_{AVWL}$	Address Setup Time $\bar{W}$ Low	0		0		0		ns	
$t_{AS}$	$t_{AVEL}$	Address Setup Time $\bar{E}$ Low	0		0		0		ns	
$t_{CEW}$	$t_{ELEH}$	Chip Enable to End of Write	90		120		160		ns	
$t_{AW}$	$t_{AVWH}$	Address Valid to End of Write	120		140		180		ns	
$t_{AW}$	$t_{AVEH}$	Address Valid to End of Write	120		140		180		ns	
$t_{WEW}$	$t_{WLWH}$	Write Pulse Width	90		120		160		ns	
$t_{AH}$	$t_{WHAX}$	$\bar{W}$ Hight to address Change	10		10		10		ns	
$t_{AH}$	$t_{EHAX}$	$\bar{E}$ Hight to address Change	10		10		10		ns	
$t_{WR}$	$t_{WHWL}$	$\bar{W}$ Hight to $\bar{W}$ Low Next Cycle	10		10		10		ns	
$t_{WEZ}$	$t_{WLOZ}$	$\bar{W}$ Data Off Time		50		60		80	ns	
$t_{CEZ}$	$t_{EHQZ}$	$\bar{E}$ Data Off Time		50		60		80	ns	
$t_{DS}$	$t_{DVWH}$	Data Setup Time to $\bar{w}$ Hight	40		60		100		ns	
$t_{DS}$	$t_{DVEH}$	Data Setup Time to $\bar{E}$ Hight	40		60		100		ns	
$t_{DH}$	$t_{WHDX}$	Data Hold Time $\bar{W}$ High	0		0		0		ns	
$t_{DH}$	$t_{EHDX}$	Data Hold Time $\bar{E}$ High	0		0		0		ns	

FIGURE 3 : WRITE CYCLE TIMING

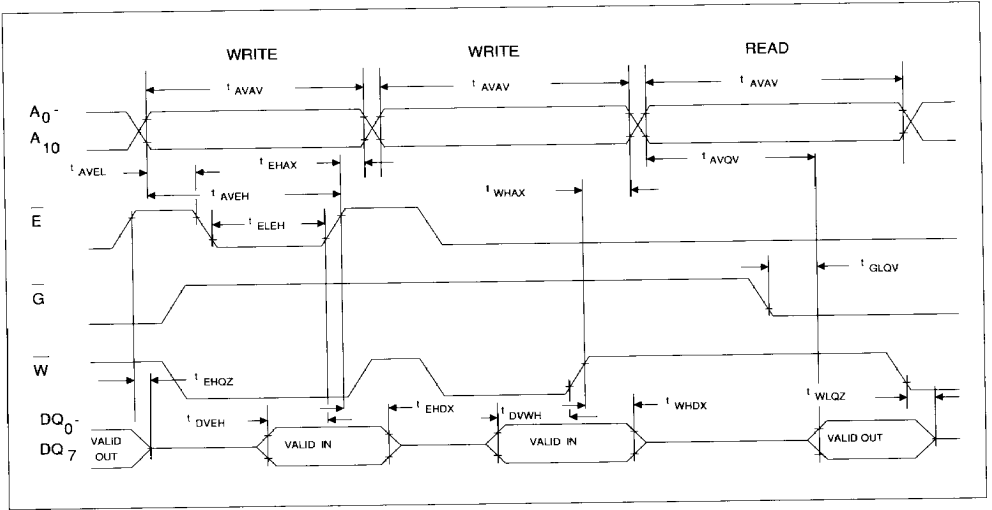
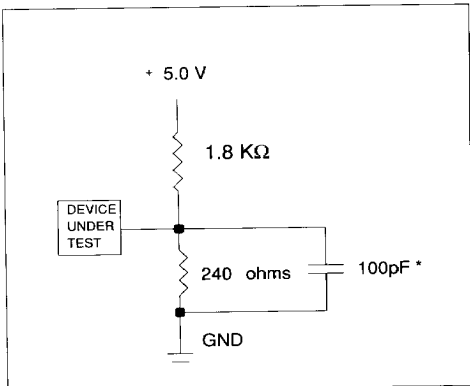

FIGURE 4 : OUTPUT LOAD DIAGRAM



AC TEST CONDITION

Input Levels: . . . . . 0.6 V to 2.4 V

Transition Times: . . . . . 5 ns

Input and Output Timing

Reference Levels: . . . . . 0.8V or 2.2 V

\*Notes: Including scope and JIG

**ABOLUTE MAXIMUM RATINGS \***

PARAMETER	VALUES	UNITS
Voltage on any Pin Relative tro Ground	-0.3 to +7.0	V
Operating Temperature (MK6116L)	0 to +7	°C
Operatting Temperature (MKI6116/L)	-40 to +150	°C
Storage Temperature	-55 to +150	°C
Power Dissipation	1	W
Output Current	† 20	mA

\* This is a stress rating only and functional operation of the device at these or any conditions above those indicazted in the operation section of this specification is not implied. Exposure to absolute maximum rating conditions for extended periods of time may affect reliability.

† Output current absolute maximum rating is specified for one output at a time, not to exceed a duration of a1 second.

**RECOMMENDED DC OPERATING CONDITIONS**

{0°C ≤ TA ≤ +70°C (MK6116/L), -40°C ≤ TA ≤ +150°C (MKI6116/L), VCC=5.0 +/- 10%

SYMBOL	PARAMETER	MIN	MAX	UNITS	NOTES
VCC	Supply Voltage	4.5	5.5.	V	4
VSS	Supply Voltage	0	0	V	4
V <sub>IH</sub>	Logic 1 All Inputs	2.2	V <sub>cc</sub> +0.3	V	4
V <sub>IL</sub>	Logic 1 All Inputs	-0.3	0.8	V	4,5

**DC ELECTRICAL CHARACTERISTICS**

{0°C ≤ TA ≤ +70°C (MK6116/L), -40°C ≤ TA ≤ +150°C (MKI6116/L), VCC=5.0 +/- 10%

SYMBOL	PARAMETER	MIN	MAX	UNITS	NOTES
I <sub>CC</sub>	Average V <sub>CC</sub> Power Supply Current ,		70	mA	6
	MK6116, MKI6116				
	MK6116L, MKI6116L		70	mA	
I <sub>SB1</sub>	TTL Standby Current ( $\bar{E} = V_{IH}$ )		3	mA	
I <sub>SB2</sub>	CMOS Standby Current ( $\bar{E} \geq V_{CC}-0.2 V$ )		1	mA	
	MK6116, MKI6116			μA	
	MK6116L			10	
I <sub>LI</sub>	Input Leakage Current	-1	+1	μA	7
I <sub>LO</sub>	Output Leakage Current	-5	+5	μA	7
V <sub>OH</sub>	Output Logic 1 Voltage (I <sub>OH</sub> = -1.0 mA)	2.4		V	
V <sub>OL</sub>	Output Logic 2 Voltage (I <sub>OH</sub> = 2.1 mA)		0.4	V	

**LOW V<sub>CC</sub> Data RETENTION CHARACTERISTICS (MK6116L, MKI6116L)**

SYMBOL	PARAMETER	MIN	MAX	UNITS	NOTES
V <sub>DR</sub>	V <sub>CC</sub> Data retention	2.0	V <sub>CC</sub> (max)		
I <sub>CCDR</sub>	Data Retention Power Supply Current		1	μA	8
	MK6116L		3	μA	
	MKI6116L				
t <sub>CDR</sub>	Chip Deselection to Data Retention Time	0		ns	
t <sub>R</sub>	Operation Recovery Time	t <sub>AVAV</sub>			

\* t<sub>AVAV</sub> = Read Cycle Time

**FIGURE 5 . LOW V<sub>CC</sub> DATA RETENTION TIMING**

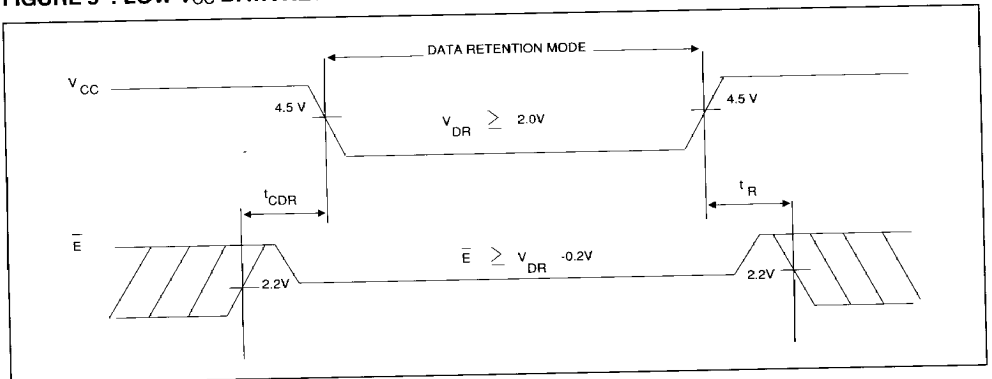

**NOTES:**

1. Measured with load as shown in Figure 4.
2. Effective capacitance calculated from the equation:  
C = IΔt/ΔV, with ΔV = 3 volts and power supply at nominal level
3. Output is deselected.
4. All voltages referenced to GND.

5. Negative spikes of -1.0 volts allowed for up to 10 ns once per cycle.
6. ICC1 measured with output open.
7. Measured with GND ≤ V ≤ V<sub>CC</sub> and outputs deselected.
8. V<sub>CC</sub> = 2.0 Volts.

**CAPACITANCE (TA = 25°C)**

SYMBOL	PARAMETER	MAX	UNITS	NOTES
C <sub>I</sub>	Capacitance on all pins (except DQ)	7.0	pF	2
C <sub>DQ</sub>	Capacitance on DQ pins	10.0	pF	2, 3

FIGURE 6 . 24-PIN PLASTIC DIP (N)

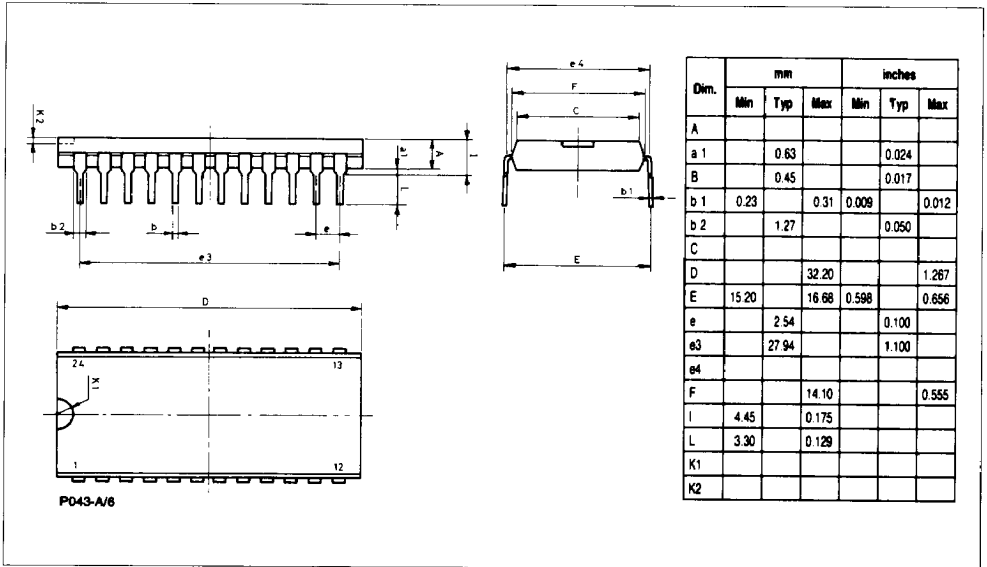
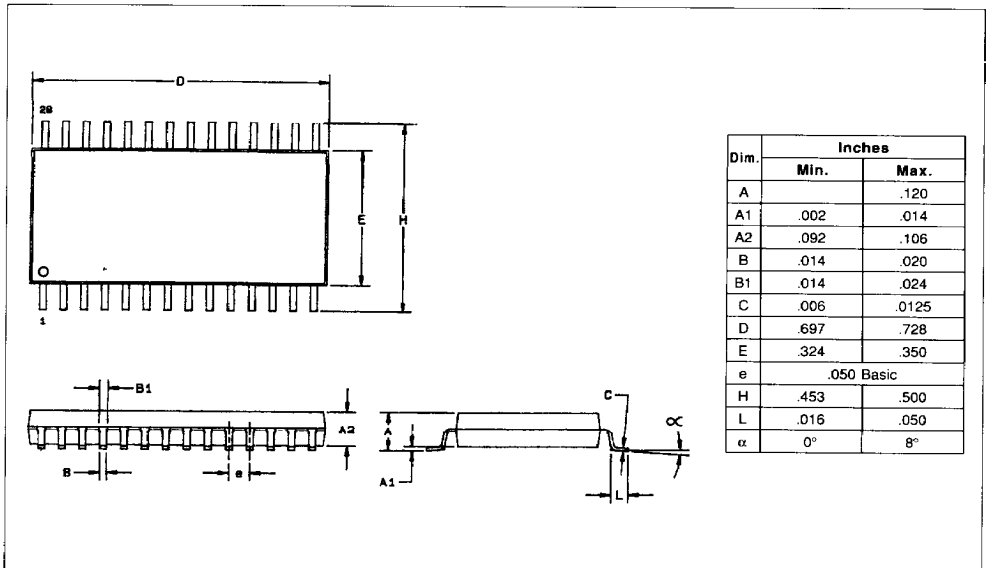

FIGURE 7 . 28-PIN SOIC (S)





**ORDERING INFORMATION**

PART NO.	ACCESS TIME	CYCLE TIME	PACKAGE TYPE	TEMPERATURE
MK6116 (N/S)-15	150 ns	150 ns	Plastic DIP/SOIC	0°C to 70°C
MK6116 (N)-20	200 ns	200 ns	Plastic DIP	0°C to 70°C
MK6116 (N) -25	250 ns	250 ns	Plastic DIP	0°C to 70°C
MKI6116 (N/S) -15	150 ns	150 ns	Plastic DIP/SOIC	-40°C to 105°C
MKI6116 (N) -20	200 ns	200 ns	Plastic DIP	-40°C to 105°C
MKI6116 (N) - 25	250 ns	250 ns	Plastic DIP	-40°C to 105°C
MK6116 L(N/S) -15	150 ns	150 ns	Plastic DIP/SOIC	0°C to 70°C
MK6116 L(N) - 20	200 ns	200 ns	Plastic DIP	0°C to 70°C
MK6116 L(N) - 25	250 ns	250 ns	Plastic DIP	0°C to 70°C
MKI6116 L(N/S) - 15	150 ns	150 ns	Plastic DIP/SOIC	-40°C to 105°C
MKI6116L (N) - 20	200 ns	200 ns	Plastic DIP	-40°C to 105°C

**MK** \_\_\_\_\_ Commercial Temperature Range (0°C to +70°C)  
**MKI** \_\_\_\_\_ Industrial Temperature Range (-40°C to +85°C)  
**6116** \_\_\_\_\_ Device Family and Identification Number  
**L** \_\_\_\_\_ Low Power  
**N** \_\_\_\_\_ Plastic Dip Package  
**S** \_\_\_\_\_ SOIC Package  
**15/20/25** \_\_\_\_\_ Speed Grade

**BYTEWYDE** is a Trademark of SGS-THOMSON Microelectronics