

QUAD 2-INPUT NAND GATE

- **HIGH SPEED**
 $t_{PD} = 8 \text{ ns (TYP.)}$ at $V_{CC} = 5\text{V}$
- **LOW POWER DISSIPATION**
 $I_{CC} = 1 \mu\text{A (MAX.)}$ at $T_A = 25^\circ\text{C}$
- **HIGH NOISE IMMUNITY**
 $V_{NIH} = V_{NIL} = 28\% V_{CC}$ (MIN.)
- **OUTPUT DRIVE CAPABILITY**
 10 LSTTL LOADS
- **BALANCED PROPAGATION DELAYS**
 $t_{PLH} = t_{PHL}$
- **WIDE OPERATING VOLTAGE RANGE**
 V_{CC} (OPR) = 2V to 6V
- **PIN AND FUNCTION COMPATIBLE**
 WITH 54/74LS00
- **SYMMETRICAL OUTPUT IMPEDANCE**
 $|I_{OH}| = I_{OL} = 4\text{mA (MIN)}$

DESCRIPTION

The M54/74HC00 is a high speed CMOS QUAD 2-INPUT NAND GATE fabricated in silicon gate C²MOS technology. It has the same high speed performance of LSTTL combined with true CMOS low power consumption. The internal circuit is composed of 3 stages including buffer output, which enables high noise immunity and stable output. All inputs are equipped with protection circuits against static discharge and transient excess voltage.

INPUT AND OUTPUT EQUIVALENT CIRCUIT

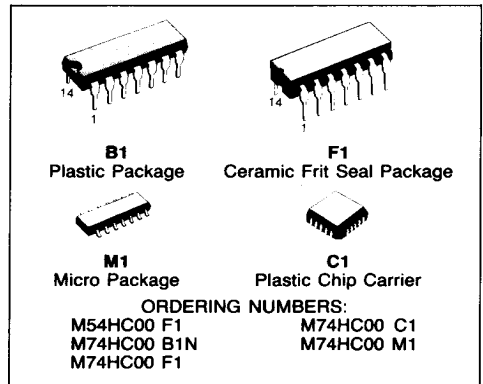
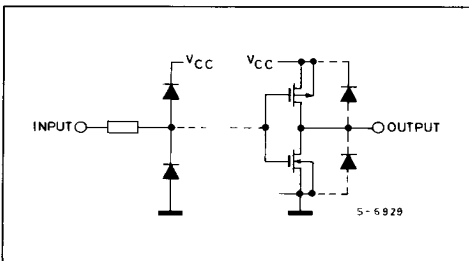

PIN CONNECTIONS (top view)

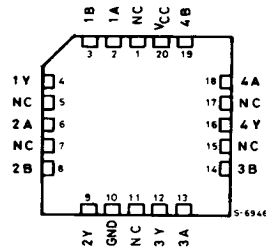
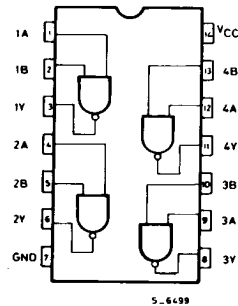

NC =
No Internal
Connection

CIRCUIT SCHEMATIC (Per Gate)

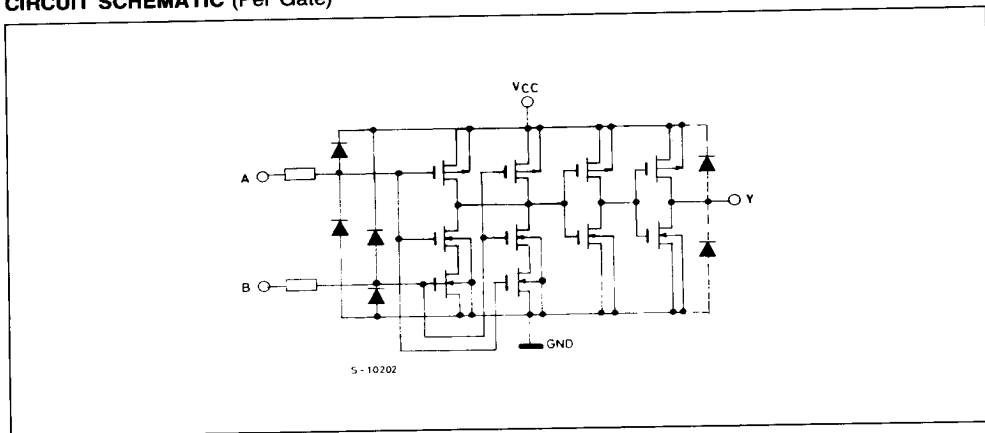

ABSOLUTE MAXIMUM RATINGS

Symbol	Parameter	Value	Unit
V _{CC}	Supply Voltage	- 0.5 to 7	V
V _I	DC Input Voltage	- 0.5 to V _{CC} + 0.5	V
V _O	DC Output Voltage	- 0.5 to V _{CC} + 0.5	V
I _{IK}	DC Input Diode Current	± 20	mA
I _{OK}	DC Output Diode Current	± 20	mA
I _O	DC Output Source Sink Current Per Output Pin	± 25	mA
I _{CC} or I _{GND}	DC V _{CC} or Ground Current	± 50	mA
P _D	Power Dissipation	500 (*)	mW
T _{stg}	Storage Temperature	- 65 to 150	°C

Absolute Maximum Ratings are those values beyond which damage to the device may occur. Functional operation under these condition is not implied.

(*) 500 mW: ≅ 65°C derate to 300 mW by 10 mW/°C: 65°C to 85°C.

RECOMMENDED OPERATING CONDITIONS

Symbol	Parameter	Value	Unit
V _{CC}	Supply Voltage	2 to 6	V
V _I	Input Voltage	0 to V _{CC}	V
V _O	Output Voltage	0 to V _{CC}	V
T _A	Operating Temperature	74HC Series 54HC Series	°C
t _r , t _f	Input Rise and Fall Time	V _{CC} { 2 V 4.5V 6 V	ns
			0 to 1000 0 to 500 0 to 400

DC SPECIFICATIONS

Symbol	Parameter	V _{CC}	Test Condition	T _A = 25°C 54HC and 74HC			- 40 to 85°C 74HC		- 55 to 125°C 54HC		Unit	
				Min.	Typ.	Max.	Min.	Max.	Min.	Max.		
V _{IH}	High Level Input Voltage	2.0		1.5	—	—	1.5	—	1.5	—	V	
		4.5		3.15	—	—	3.15	—	3.15	—		
		6.0		4.2	—	—	4.2	—	4.2	—		
V _{IL}	Low Level Input Voltage	2.0		—	—	0.5	—	0.5	—	0.5	V	
		4.5		—	—	1.35	—	1.35	—	1.35		
		6.0		—	—	1.8	—	1.8	—	1.8		
V _{OH}	High Level Output Voltage	2.0	V _I	I _O	1.9	2.0	—	1.9	—	1.9	—	V
		4.5	V _{IH}	- 20 μA	4.4	4.5	—	4.4	—	4.4	—	
		6.0	V _{IH}	- 20 μA	5.9	6.0	—	5.9	—	5.9	—	
		4.5	V _{IL}	- 4.0 mA	4.18	4.31	—	4.13	—	4.10	—	
6.0	V _{IL}	- 5.2 mA	5.68	5.8	—	5.63	—	5.60	—			
V _{OL}	Low Level Output Voltage	2.0	V _{IH} or V _{IL}	20 μA	—	0.0	0.1	—	0.1	—	0.1	V
		4.5			—	0.0	0.1	—	0.1	—	0.1	
		6.0			—	0.0	0.1	—	0.1	—	0.1	
		4.5			4.0 mA	—	0.17	0.26	—	0.33	—	
6.0	V _{IL}	5.2 mA	—	0.18	0.26	—	0.33	—	0.40			
I _I	Input Leakage Current	6.0	V _I = V _{CC} or GND		—	—	± 0.1	—	± 1.0	—	± 1.0	μA
I _{CC}	Quiescent Supply Current	6.0	V _I = V _{CC} or GND		—	—	1	—	10	—	20	μA

AC ELECTRICAL CHARACTERISTICS (V_{CC} = 5V, T_A = 25°C, C_L = 15pF, Input t_r = t_f = 6ns)

Symbol	Parameter	54HC and 74HC			Unit
		Min.	Typ.	Max.	
t _{TLH} t _{THL}	Output Transition Time		4	8	ns
t _{PLH} t _{PHL}	Propagation Delay Time		9	15	ns

AC ELECTRICAL CHARACTERISTICS (C_L = 50pF, Input t_r = t_f = 6ns)

Symbol	Parameter	V _{CC}	Test Condition	T _A = 25°C 54HC and 74HC			- 40 to 85°C 74HC		- 55 to 125°C 54HC		Unit
				Min.	Typ.	Max.	Min.	Max.	Min.	Max.	
t _{TLH} t _{THL}	Output Transition Time	2.0 4.5 6.0		— — —	30 8 7	75 15 13	— — —	95 19 16		110 22 19	ns
t _{PLH} t _{PHL}	Propagation Delay Time	2.0 4.5 6.0		— — —	40 10 9	90 18 15	— — —	115 23 20		135 27 23	ns
C _{IN}	Input Capacitance			—	5	10	—	10		10	pF
C _{PD} (*)	Power Dissipation Capacitance			—	22	—	—	—			pF

Note (*) C_{PD} is defined as the value of the IC's internal equivalent capacitance which is calculated from the operating current consumption without load. (Refer to Test Circuit)
 Average operating current can be obtained by the following equation.
 $I_{CC(opr)} = C_{PD} \cdot V_{CC} \cdot f_{IN} + I_{CC}/6$ (per Gate).

SWITCHING CHARACTERISTICS TEST CIRCUIT

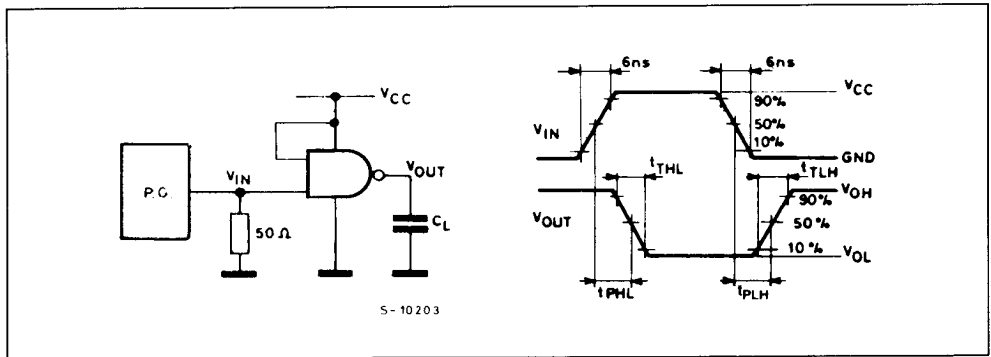

TEST CIRCUIT I_{CC} (Opr.)

