

# TA76524P

BIPOLAR LINEAR INTEGRATED CIRCUIT  
SILICON MONOLITHIC

## ○ GENERAL PURPOSE SWITCHING REGULATOR (3524 TYPE)

The TA76524P is an IC developed for constant voltage power supply by switching system. This switching regulator assures high level of conversion efficiency.

- Pulse width modulation (P.W.M.) system
- Output in single-end or push-pull system is possible.
- Low current consumption at no-load  
: 5mA (standard)
- Computible with SC3524

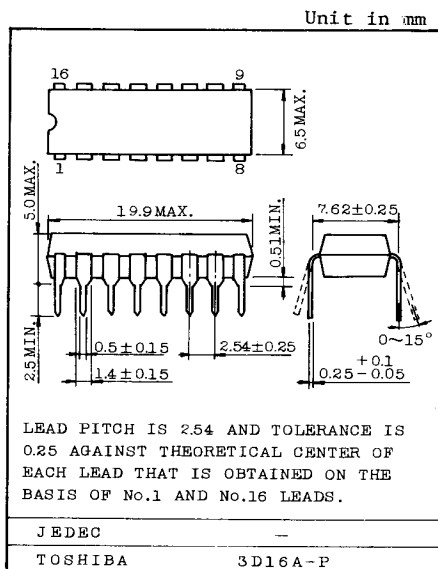

## MAXIMUM RATINGS (Ta=25°C)

CHARACTERISTIC	SYMBOL	RATING	UNIT
Supply Voltage (Note 1,2)	V <sub>CC</sub>	40	V
Collector Output Current	I <sub>C</sub>	100	mA
Reference Output Current	I <sub>REF</sub>	50	mA
C <sub>T</sub> Terminal Current	I <sub>CT</sub>	5	mA
Power Consumption (Note 3)	P <sub>D</sub>	750	mW
Operating Temperature	T <sub>opr</sub>	-30 ~ 75	°C
Storage Temperature	T <sub>stg</sub>	-55 ~ 125	°C

- Note 1. Voltage between V<sub>CC</sub> - GND terminal.
2. 5V can be used with V<sub>CC</sub> and V<sub>REF</sub> terminals shorted.  
At this time, max. is 6V.
3. Reduce 6mW every time when temperature rises by 1°C.

BLOCK DIAGRAM

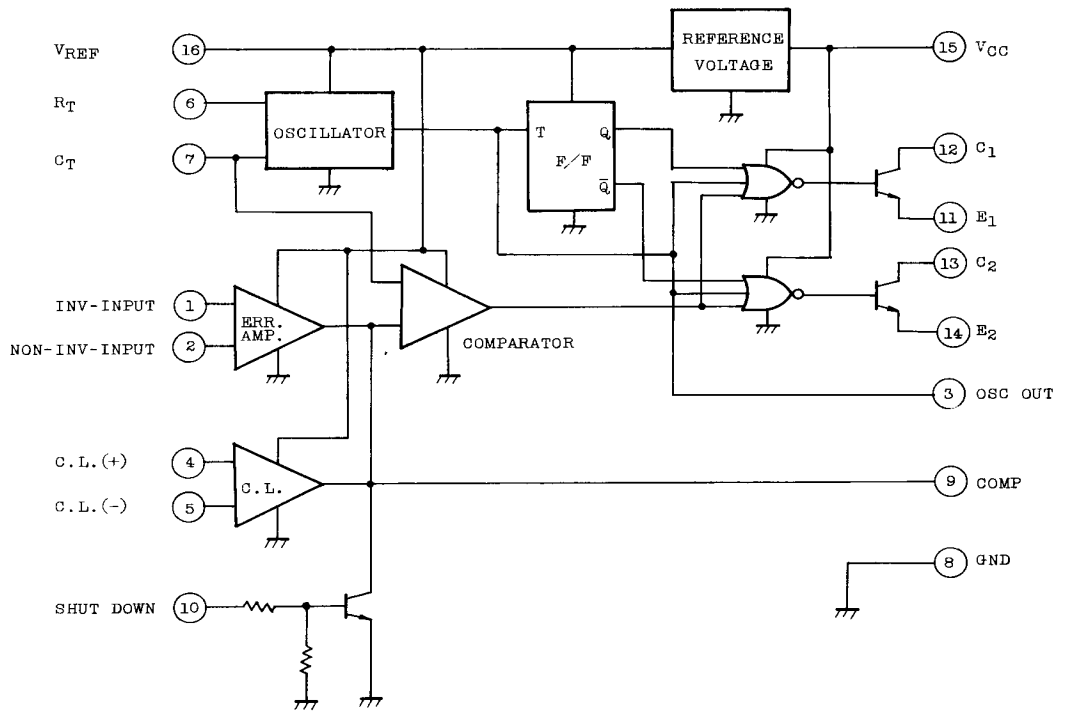

# TA76524P

ELECTRICAL CHARACTERISTICS ( $V_{CC}=20V$ ,  $f=20kHz$ ,  $T_a=25^{\circ}C$ )

## REFERENCE VOLTAGE UNIT

CHARACTERISTIC	SYMBOL	TEST CONDITION	MIN.	TYP.	MAX.	UNIT
Reference Voltage	$V_{REF}$		4.6	5.0	5.4	V
Input Regulation	Reg.Line	$V_{CC}=8 \sim 40V$	-	10	30	mA
Refresh Rejection	R.R.	$f = 120Hz$	-	66	-	dB
Output Regulation	Reg.Load	$I_O = 0 \sim 20mA$	-	20	50	mV
Output Voltage Temp. Coefficient	$TC_{VO}$	$T_a = 0 \sim 70^{\circ}C$	-	0.3	1.0	%
		$T_a = -30 \sim 75^{\circ}C$	-	0.4	1.36	
Output Short-Circuit Current	$I_{SC}$	$V_{REF} = 0$ 1 sec (Max.)	-	100	-	mA

## ERROR AMPLIFIER UNIT

CHARACTERISTIC	SYMBOL	TEST CONDITION	MIN	TYP	MAX.	UNIT
Input Offset Voltage	$V_{IO}$	$V_{IC} = 2.5V$	-	2	10	mV
Input Bias Current	$I_I$	$V_{IC} = 2.5V$	-	1	10	$\mu A$
Open Loop Voltage Gain	$G_{VO}$		60	80	-	dB
Common Mode Input Voltage Range	$MV_{IN}$	$T_a = 25^{\circ}C$	1.8	-	3.4	V
Common Mode Rejection Ratio	CMRR		-	70	-	dB
Bandwidth	BW		-	3	-	MHz
Output Voltage Swing	$V_{Op-p}$	$T_a = 25^{\circ}C$	0.5	-	3.8	V

CHARACTERISTIC	SYMBOL	TEST CONDITION	MIN.	TYP.	MAX.	UNIT
Max. Oscillation Frequency	$f_{MAX.}$	$C_T = 0.001 \mu F$ , $R_T = 2k\Omega$	-	450	-	kHz
Frequency Accuracy	$f_{S.D.}$	$V_{CC}=8 \sim 40V$ , $R_T=1.8 \sim 100k\Omega$ $C=Const.$	-	5	-	%
Frequency Stability	$f/\Delta V_{CC}$	$V_{CC} = 8 \sim 40V$	-	0.4	-	%
		$T_a = 0 \sim 70^{\circ}C$	-	5	-	
		$T_a = -30 \sim 75^{\circ}C$	-	7	-	%
Output Voltage Swing	$V_{O3}$	3 PIN	-	3.5	-	V
Output Pulse Width	$t_p$	$C_T = 0.01 \mu F$ , 3 pins	-	0.5	-	$\mu s$

## COMPARATOR UNIT

CHARACTERISTIC	SYMBOL	TEST CONDITION	MIN	TYP	MAX	UNIT
Max. Duty Cycle	D <sub>MAX</sub>		45	-	-	%
Fresh Hold Voltage	V <sub>TH 0</sub>	duty = 0	-	1.0	-	V
	V <sub>THMAX</sub>	duty = Max.	-	3.5	-	
Input Bias Current	I <sub>I</sub>		-	-1	-	μA

## CURRENT LIMITER UNIT

CHARACTERISTIC	SYMBOL	TEST CONDITION	MIN	TYP	MAX	UNIT
Input Voltage Range	V <sub>IS</sub>		-0.7 ~ 1.0	-	-	V
Sense Voltage	V <sub>S</sub>	9 Pin = 2V, V(1Pin-2Pin) ≥ 50mV, Ta=25°C	180	200	220	mV
Sense Voltage Temp. Coefficient	TC <sub>V<sub>S</sub></sub>	Ta = -30 ~ 75°C	-	0.2	-	mV/°C

## OUTPUT UNIT

CHARACTERISTIC	SYMBOL	TEST CONDITION	MIN	TYP	MAX	UNIT
Collector/Emitter Breakdown Voltage	V <sub>CE</sub>		40	-	-	V
Output Leak Current	I <sub>CO</sub>	V <sub>CE</sub> = 40V	-	0.01	50	μA
Output Saturation Voltage	V <sub>CE(sat)</sub>	I <sub>C</sub> = 50mA	-	1	2	V
Emitter Output Voltage	V <sub>E</sub>	V <sub>C</sub> = 20V, I <sub>E</sub> = -250μA	17	18	-	V
Rise Time	t <sub>r</sub>	R <sub>C</sub> = 2kΩ	-	0.2	-	μs
Fall Time	t <sub>f</sub>		-	0.1	-	

## TOTAL DEVICE

CHARACTERISTIC	SYMBOL	TEST CONDITION	MIN	TYP	MAX	UNIT
Bias Current	I <sub>B</sub>	V <sub>CC</sub> = 40V	-	5	10	mA