



74VCXH16374

LOW VOLTAGE 16-BIT D-TYPE FLIP FLOP (3-STATE) WITH 3.6V TOLERANT INPUTS AND OUTPUTS

PRELIMINARY DATA

- 3.6V TOLERANT INPUTS AND OUTPUTS
- HIGH SPEED:
 $t_{PD} = 3.0 \text{ ns (MAX.) at } V_{CC} = 3.0 \text{ to } 3.6\text{V}$
 $t_{PD} = 3.9 \text{ ns (MAX.) at } V_{CC} = 2.3 \text{ to } 2.7\text{V}$
- POWER-DOWN PROTECTION ON INPUTS AND OUTPUTS
- SYMMETRICAL OUTPUT IMPEDANCE:
 $|I_{OH}| = I_{OL} = 24 \text{ mA (MIN) at } V_{CC} = 3.0\text{V}$
 $|I_{OH}| = I_{OL} = 18 \text{ mA (MIN) at } V_{CC} = 2.3\text{V}$
- OPERATING VOLTAGE RANGE:
 $V_{CC} \text{ (OPR)} = 1.8\text{V to } 3.6\text{V}$
- PIN AND FUNCTION COMPATIBLE WITH 74 SERIES 16374
- LATCH-UP PERFORMANCE EXCEEDS 300mA
- ESD PERFORMANCE:
 $\text{HBM} > 2000\text{V}; \text{MM} > 200\text{V}$

DESCRIPTION

The VCXH16374 is a low voltage CMOS 16-BIT D-TYPE FLIP FLOP with 3 STATE OUTPUT NON INVERTING fabricated with sub-micron silicon gate and five-layer metal wiring C²MOS technology. It is ideal for low power and very high speed 2.3 to 3.6V applications; it can be interfaced to 3.6V signal environment for both inputs and outputs.

These 16 bit D-Type flip-flops are controlled by two clock inputs (nCK) and two output enable inputs (nOE). On the positive transition of the (nCK), the nQ outputs will be set to the logic state that were setup at the nD inputs. While the (nOE) input is low, the 8 outputs (nQ) will be in a normal state (high or low logic level) and while high level the outputs will be in a high impedance state.

Any output control does not affect the internal operation of flip flops; that is, the old data can be retained or the new data can be entered even while the outputs are off.

This device is designed to be used with 3 state memory address drivers, etc. Bus hold on data inputs is provided in order to eliminate the need for external pull-up or pull-down resistor.

All inputs and outputs are equipped with protection circuits against static discharge, giving them 2KV ESD immunity and transient excess voltage.



PIN CONNECTION

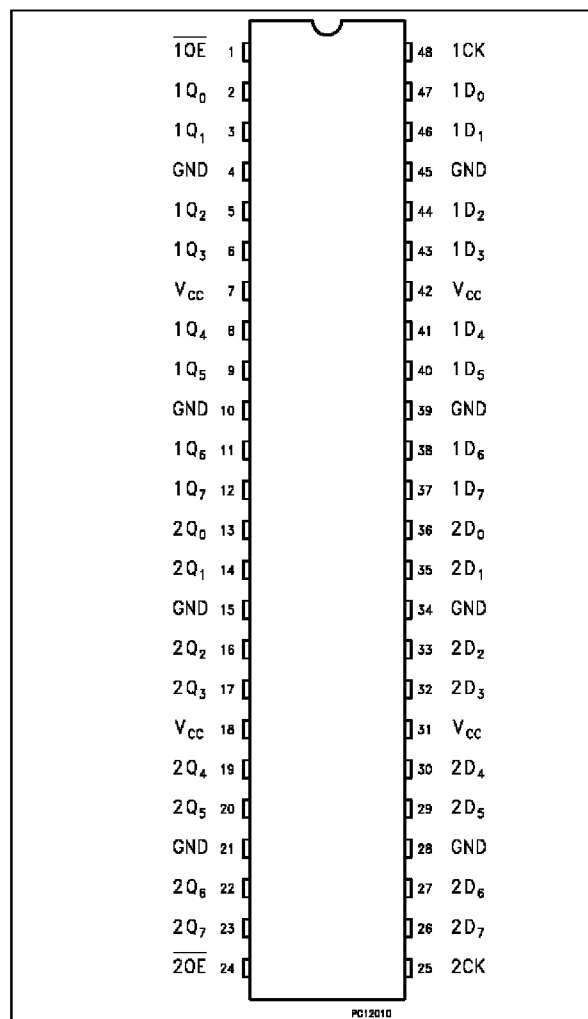

INPUT AND OUTPUT EQUIVALENT CIRCUIT

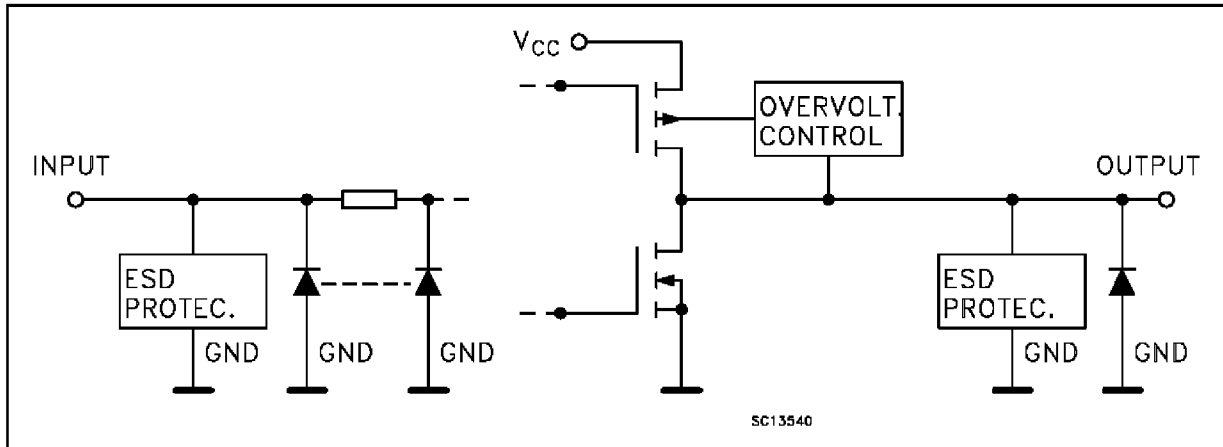

PIN DESCRIPTION

PIN No	SYMBOL	NAME AND FUNCTION
1	$\overline{1OE}$	3 State Output Enable Input (Active LOW)
2, 3, 5, 6, 8, 9, 11, 12	1Q0 to 1Q7	3 State Outputs
13, 14, 16, 17, 19, 20, 22, 23	2Q0 to 2Q7	3 State Outputs
24	$\overline{2OE}$	3 State Output Enable Input (Active LOW)
25	2CK	Clock Input (LOW to HIGH, edge triggered)
36, 35, 33, 32, 30, 29, 27, 26	2D0 to 2D7	Data Inputs
47, 46, 44, 43, 41, 40, 38, 37	1D0 to 1D7	Data Inputs
48	1CK	Clock Input (LOW to HIGH, edge triggered)
4, 10, 15, 21, 28, 34, 39, 45	GND	Ground (0V)
7, 18, 31, 42	V _{CC}	Positive Supply Voltage

IEC LOGIC SYMBOLS

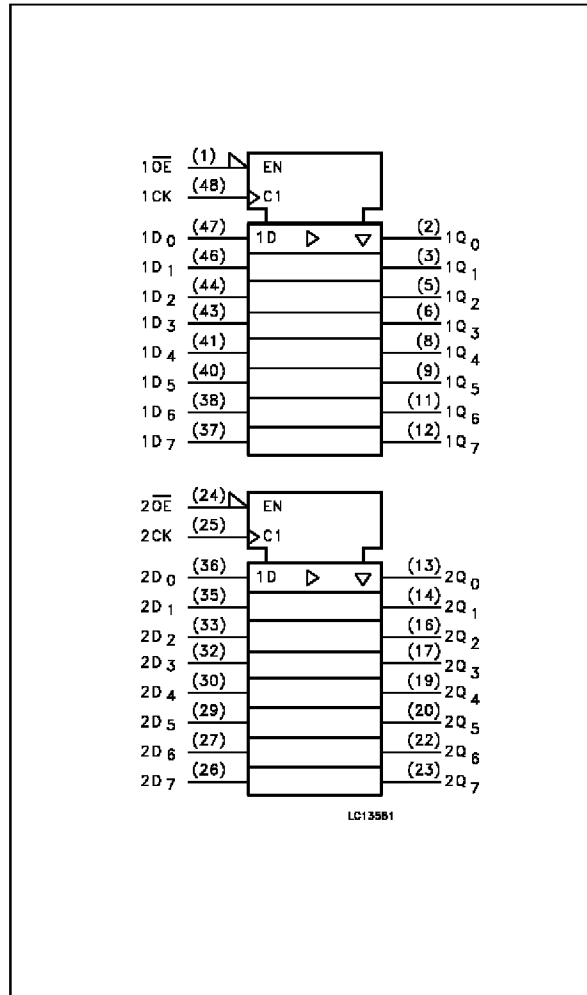

TRUTH TABLE

INPUTS			OUTPUTS
\overline{OE}	CK	D	Q
H	X	X	Z
L		X	NO CHANGE
L		L	L
L		H	H

X: "H" or "L"
Z: High Impedance

LOGIC DIAGRAM

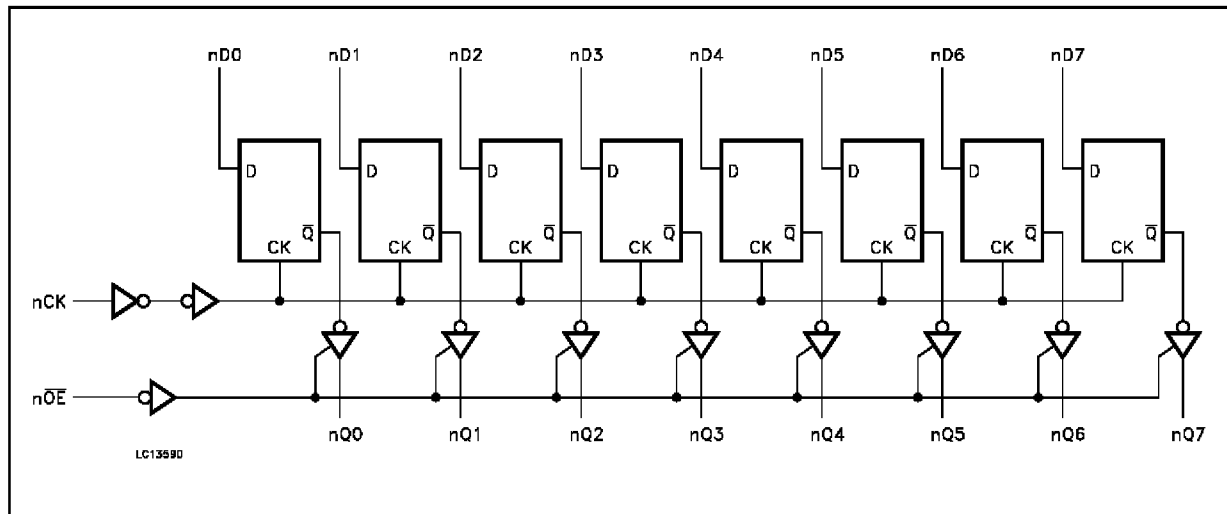

ABSOLUTE MAXIMUM RATINGS

Symbol	Parameter	Value	Unit
V_{CC}	Supply Voltage	-0.5 to +4.6	V
V_I	DC Input Voltage	-0.5 to +4.6	V
V_O	DC Output Voltage (OFF state)	-0.5 to +4.6	V
V_O	DC Output Voltage (High or Low State) (note1)	-0.5 to $V_{CC} + 0.5$	V
I_{IK}	DC Input Diode Current	-50	mA
I_{OK}	DC Output Diode Current (note2)	± 50	mA
I_O	DC Output Source/Sink Current	± 50	mA
I_{CC} or I_{GND}	DC V_{CC} or Ground Current Per Supply Pin	± 100	mA
P_D	Power Dissipation	400	mW
T_{stg}	Storage Temperature	-65 to +150	$^{\circ}C$
T_L	Lead Temperature (10 sec)	300	$^{\circ}C$

Absolute Maximum Ratings are those values beyond which damage to the device may occur. Functional operation under these condition is not implied.

1) I_O absolute maximum rating must be observed

2) $V_O < GND$, $V_O > V_{CC}$

RECOMMENDED OPERATING CONDITIONS

Symbol	Parameter	Value	Unit
V_{CC}	Supply Voltage	2.3 to 3.6	V
V_I	Input Voltage	-0.3 to 3.6	V
V_O	Output Voltage (OFF state)	0 to 3.6	V
V_O	Output Voltage (High or Low State)	0 to V_{CC}	V
I_{OH} , I_{OL}	High or Low Level Output Current ($V_{CC} = 3.0$ to $3.6V$)	± 24	mA
I_{OH} , I_{OL}	High or Low Level Output Current ($V_{CC} = 2.3$ to $2.7V$)	± 18	mA
T_{op}	Operating Temperature:	-40 to +85	$^{\circ}C$
dt/dv	Input Transition Rise or Fall Rate ($V_{CC} = 3.0V$) (note 1)	0 to 10	ns/V

1) V_{IN} from 0.8V to 2.0V, $V_{CC} = 3.0V$

DC SPECIFICATIONS (2.7V < V_{CC} ≤ 3.6V unless otherwise specified)

Symbol	Parameter	Test Conditions		Value		Unit
		V _{CC} (V)		-40 to 85 °C		
				Min.	Max.	
V _{IH}	High Level Input Voltage	2.7 to 3.6		2.0		V
V _{IL}	Low Level Input Voltage				0.8	
V _{OH}	High Level Output Voltage	2.7 to 3.6	V _I = V _{IH} or V _{IL}	I _O = -100 μA	V _{CC} - 0.2	V
		2.7		I _O = -12 mA	2.2	
		3.0		I _O = -18 mA	2.4	
		3.0		I _O = -24 mA	2.2	
V _{OL}	Low Level Output Voltage	2.7 to 3.6	V _I = V _{IH} or V _{IL}	I _O = 100 μA		V
		2.7		I _O = 12 mA	0.4	
		3.0		I _O = 18 mA	0.4	
		3.0		I _O = 24 mA	0.55	
I _I	Input Leakage Current	2.7 to 3.6	V _I = V _{CC} or GND		±5	μA
I _{I(HOLD)}	Input Hold Current	3	V _I = 0.8 V	75		μA
			V _I = 2 V	-75		
		3.6	V _I = 0 to 3.6 V		±500	
I _{OZ}	3 State Output Leakage Current	2.7 to 3.6	V _I = V _{IH} or V _{IL} V _O = 0 to 3.6V		±10	μA
I _{off}	Power Off Leakage Current	0	V _I or V _O = 0 to 3.6V		10	μA
I _{CC}	Quiescent Supply Current	2.7 to 3.6	V _I = V _{CC} or GND		20	μA
			V _I or V _O = V _{CC} to 3.6 V		±20	
ΔI _{CC}	ICC incr. per input	2.7 to 3.6	V _{IH} = V _{CC} - 0.6V		750	μA

DC SPECIFICATIONS (2.3V < V_{CC} ≤ 2.7V unless otherwise specified)

Symbol	Parameter	Test Conditions		Value		Unit
		V _{CC} (V)		-40 to 85 °C		
				Min.	Max.	
V _{IH}	High Level Input Voltage	2.3 to 2.7		1.6		V
V _{IL}	Low Level Input Voltage				0.7	
V _{OH}	High Level Output Voltage	2.3 to 2.7	V _I = V _{IH} or V _{IL}	I _O = -100 μA	V _{CC} - 0.2	V
		2.3		I _O = -6 mA	2.0	
		2.3		I _O = -12 mA	1.8	
		2.3		I _O = -18 mA	1.7	
V _{OL}	Low Level Output Voltage	2.3 to 2.7	V _I = V _{IH} or V _{IL}	I _O = 100 μA	0.2	V
		2.3		I _O = 12 mA	0.4	
		2.3		I _O = 18 mA	0.6	
I _I	Input Leakage Current	2.3 to 2.7	V _I = V _{CC} or GND		±5	μA
I _{I(HOLD)}	Input Hold Current	2.3	V _I = 0.7 V	45		μA
			V _I = 1.7 V	-45		
I _{OZ}	3 State Output Leakage Current	2.3 to 2.7	V _I = V _{IH} or V _{IL} V _O = 0 to 3.6V		±10	μA
I _{off}	Power Off Leakage Current	0	V _I or V _O = 0 to 3.6V		10	μA
I _{CC}	Quiescent Supply Current	2.3 to 2.7	V _I = V _{CC} or GND		20	μA
			V _I or V _O = V _{CC} to 3.6 V		±20	

DYNAMIC SWITCHING CHARACTERISTICS ($T_A = 25^\circ\text{C}$, Input $t_r = t_f = 2.0\text{ns}$, $C_L = 30\text{pF}$, $R_L = 500\Omega$)

Symbol	Parameter	Test Conditions		Value			Unit
		V _{CC} (V)		T _A = 25 °C			
				Min.	Typ.	Max.	
V _{OLP}	Dynamic Low Voltage Quiet Output (note 1, 3)	2.5	V _{IL} = 0 V V _{IH} = V _{CC}		0.6		V
		3.3			0.8		
V _{OLV}	Dynamic Low Voltage Quiet Output (note 1, 3)	2.5	V _{IL} = 0 V V _{IH} = V _{CC}		-0.6		V
		3.3			-0.8		
V _{OHV}	Dynamic High Voltage Quiet Output (note 2, 3)	2.5	V _{IL} = 0 V V _{IH} = V _{CC}		1.9		V
		3.3			2.2		

1) Number of outputs defined as "n". Measured with "n-1" outputs switching from HIGH to LOW or LOW to HIGH. The remaining output is measured in the LOW state.

2) Number of outputs defined as "n". Measured with "n-1" outputs switching from HIGH to LOW or LOW to HIGH. The remaining output is measured in the HIGH state.

3) Parameters guaranteed by design.

AC ELECTRICAL CHARACTERISTICS ($C_L = 30\text{ pF}$, $R_L = 500\ \Omega$, Input $t_r = t_f = 2.0\text{ ns}$)

Symbol	Parameter	Test Condition		Value		Unit
		V _{CC} (V)	Waveform	-40 to 85 °C		
				Min.	Max.	
t _{PLH} t _{PHL}	Propagation Delay Time CK to Qn	2.3 to 2.7	3	1.0	3.9	ns
		3.0 to 3.6		0.8	3.0	
t _{PZL} t _{PZH}	Output Enable Time	2.3 to 2.7	2	1.0	4.6	ns
		3.0 to 3.6		0.8	3.5	
t _{PLZ} t _{PHZ}	Output Disable Time	2.3 to 2.7	2	1.0	3.8	ns
		3.0 to 3.6		0.8	3.5	
t _s	Setup Time, HIGH or LOW level Dn to CK	2.3 to 2.7	1	1.5		ns
		3.0 to 3.6		1.5		
t _h	Hold Time, HIGH or LOW level Dn to CK	2.3 to 2.7	1	1.0		ns
		3.0 to 3.6		1.0		
t _w	CK Pulse Width, HIGH	2.3 to 2.7	1	1.5		ns
		3.0 to 3.6		1.5		
f _{MAX}	Clock Pulse Frequency	2.3 to 2.7	1	200		MHz
		3.0 to 3.6		250		
t _{OSLH} t _{OSHL}	Output to Output Skew Time (note 1, 2)	2.3 to 2.7			0.5	ns
		3.0 to 3.6			0.5	

1) Skew is defined as the absolute value of the difference between the actual propagation delay for any two outputs of the same device switching in the same direction, either HIGH or LOW ($t_{OSLH} = |t_{PLHn} - t_{PLHn}|$, $t_{OSHL} = |t_{PHLn} - t_{PHLn}|$)

2) Parameter guaranteed by design

CAPACITIVE CHARACTERISTICS

Symbol	Parameter	Test Conditions		Value			Unit
		V _{CC} (V)		T _A = 25 °C			
				Min.	Typ.	Max.	
C _{IN}	Input Capacitance	2.5 or 3.3	V _{IN} = 0V or V _{CC}		6		pF
C _{OUT}	Output Capacitance	2.5 or 3.3	V _{IN} = 0V or V _{CC}		7		pF
C _{PD}	Power Dissipation Capacitance (note 1)	2.5 or 3.3	f _{IN} = 10MHz V _{IN} = 0V or V _{CC}		20		pF

1) C_{PD} is defined as the value of the IC's internal equivalent capacitance which is calculated from the operating current consumption without load. Average operating current can be obtained by the following equation. $I_{cc(oper)} = C_{PD} \cdot V_{CC} \cdot f_{IN} + I_{cc}/16$ (per circuit)

TEST CIRCUIT

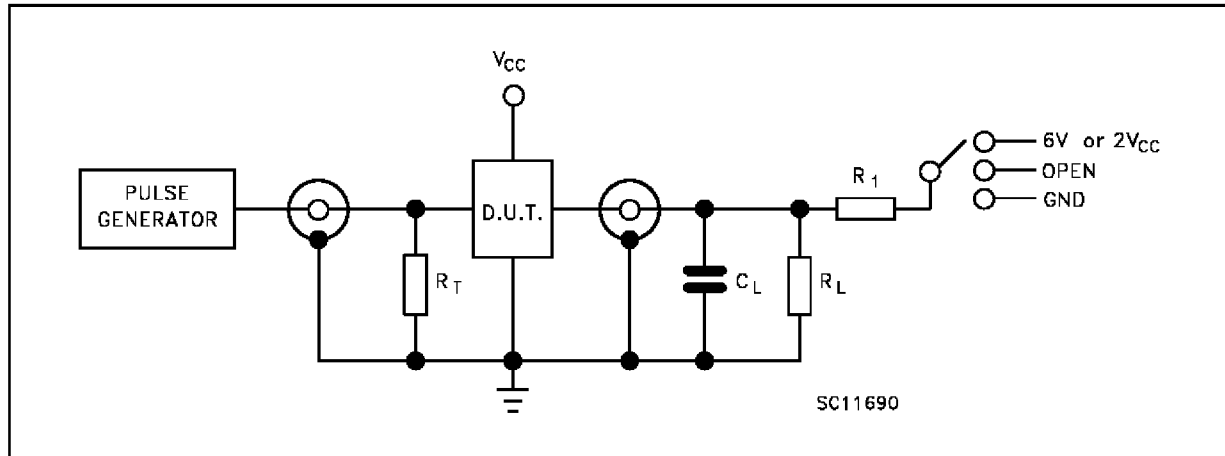

TEST	SWITCH
t_{PLH} , t_{PHL}	Open
t_{PZL} , t_{PLZ} ($V_{CC} = 3.0$ to $3.6V$)	6V
t_{PZL} , t_{PLZ} ($V_{CC} = 2.3$ to $2.7V$)	$2V_{CC}$
t_{PZH} , t_{PHZ}	GND

$C_L = 30$ pF or equivalent (includes jig and probe capacitance)

$R_L = R_1 = 500\Omega$ or equivalent

$R_T = Z_{out}$ of pulse generator (typically 50Ω)

WAVEFORM SYMBOL VALUES

Symbol	V_{CC}	
	3.0 to 3.6V	2.3 to 2.7V
V_{IH}	2.7V	V_{CC}
V_M	1.5V	$V_{CC}/2$
V_X	$V_{OL} + 0.3V$	$V_{OL} + 0.15V$
V_Y	$V_{OH} - 0.3V$	$V_{OH} - 0.15V$

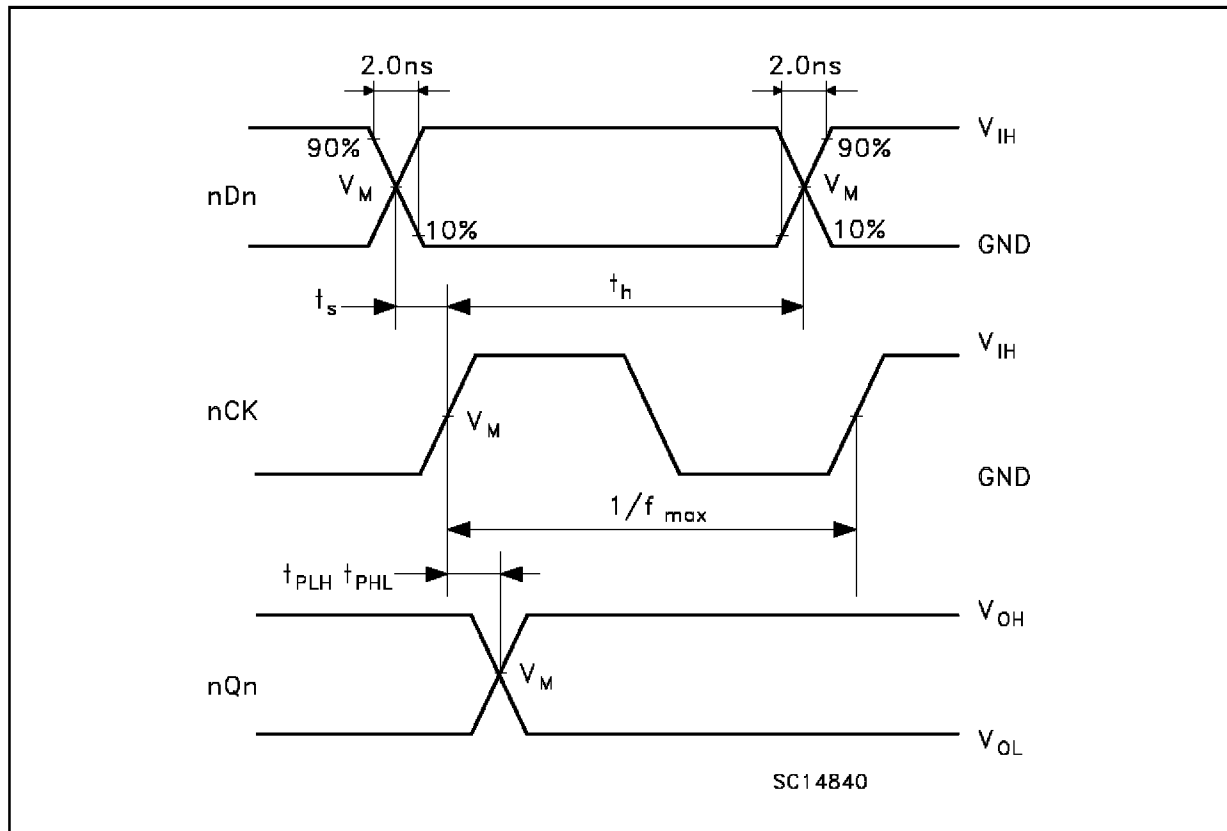
WAVEFORM 1: PROPAGATION DELAYS, SETUP AND HOLD TIMES ($f=1\text{MHz}$; 50% duty cycle)

WAVEFORM 2: OUTPUT ENABLE AND DISABLE TIMES (f=1MHz; 50% duty cycle)

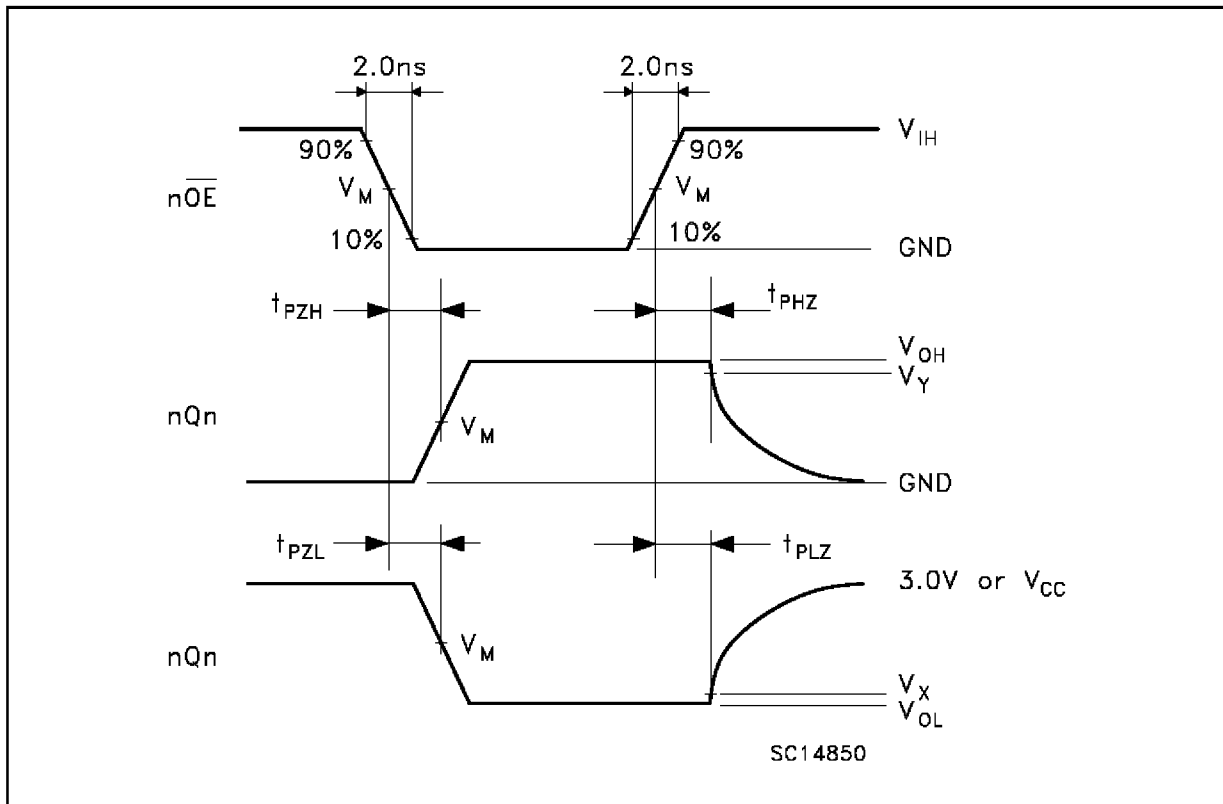

WAVEFORM 3: PULSE WIDTH

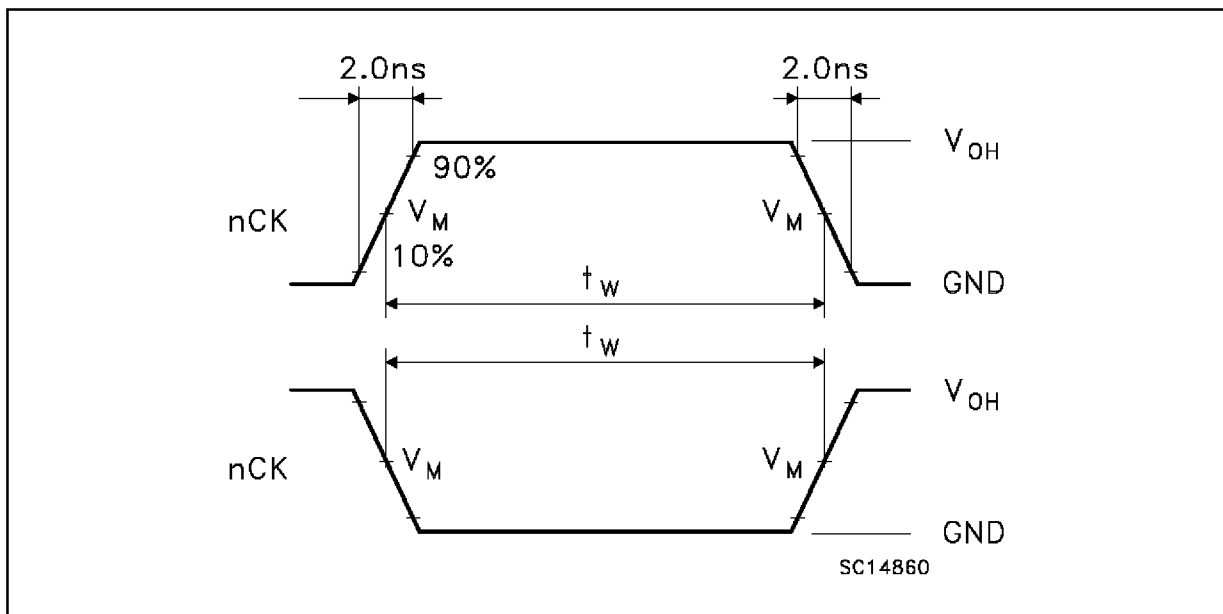

TSSOP48 MECHANICAL DATA

DIM.	mm			inch		
	MIN.	TYP.	MAX.	MIN.	TYP.	MAX.
A			1.1			0.433
A1	0.05	0.10	0.15	0.002	0.004	0.006
A2	0.85	0.9	0.95	0.335	0.354	0.374
b	0.17		0.27	0.0067		0.011
c	0.09		0.20	0.0035		0.0079
D	12.4	12.5	12.6	0.408	0.492	0.496
E	7.95	8.1	8.25	0.313	0.319	0.325
E1	6.0	6.1	6.2	0.236	0.240	0.244
e		0.5 BSC			0.0197 BSC	
K	0°	4°	8°	0°	4°	8°
L	0.50	0.60	0.70	0.020	0.024	0.028

