

HIGH PERFORMANCE CURRENT MODE PWM CONTROLLER

- TRIMMED OSCILLATOR DISCHARGE CURRENT
- CURRENT MODE OPERATION TO 500kHz
- AUTOMATIC FEED FORWARD COMPENSATION
- LATCHING PWM FOR CYCLE-BY-CYCLE CURRENT LIMITING
- INTERNALLY TRIMMED REFERENCE WITH UNDERVOLTAGE LOCKOUT
- HIGH CURRENT TOTEM POLE OUTPUT
- UNDERVOLTAGE LOCKOUT WITH HYSTERESIS
- LOW START-UP CURRENT (< 0.5mA)
- DOUBLE PULSE SUPPRESSION

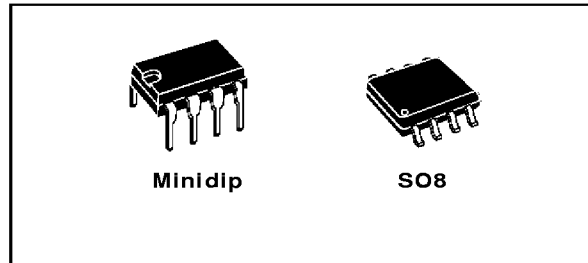

comparator which also provides current limit control, and a totem pole output stage designed to source or sink high peak current. The output stage, suitable for driving N-Channel MOSFETs, is low in the off-state.

Differences between members of this family are the under-voltage lockout thresholds and maximum duty cycle ranges. The UC3842A and UC3844A have UVLO thresholds of 16V (on) and 10V (off), ideally suited off-line applications. The corresponding thresholds for the UC3843A and UC3845A are 8.5 V and 7.9V. The UC3842A and UC3843A can operate to duty cycles approaching 100%. A range of the zero to < 50 % is obtained by the UC3844A and UC3845A by the addition of an internal toggle flip flop which blanks the output off every other clock cycle.

DESCRIPTION

The UC384xA family of control ICs provides the necessary features to implement off-line or DC to DC fixed frequency current mode control schemes with a minimal external parts count. Internally implemented circuits include a trimmed oscillator for precise DUTY CYCLE CONTROL under voltage lock-out featuring start-up current less than 0.5mA, a precision reference trimmed for accuracy at the error amp input, logic to insure latched operation, a PWM

BLOCK DIAGRAM (toggle flip flop used only in UC3844A and UC3845A)

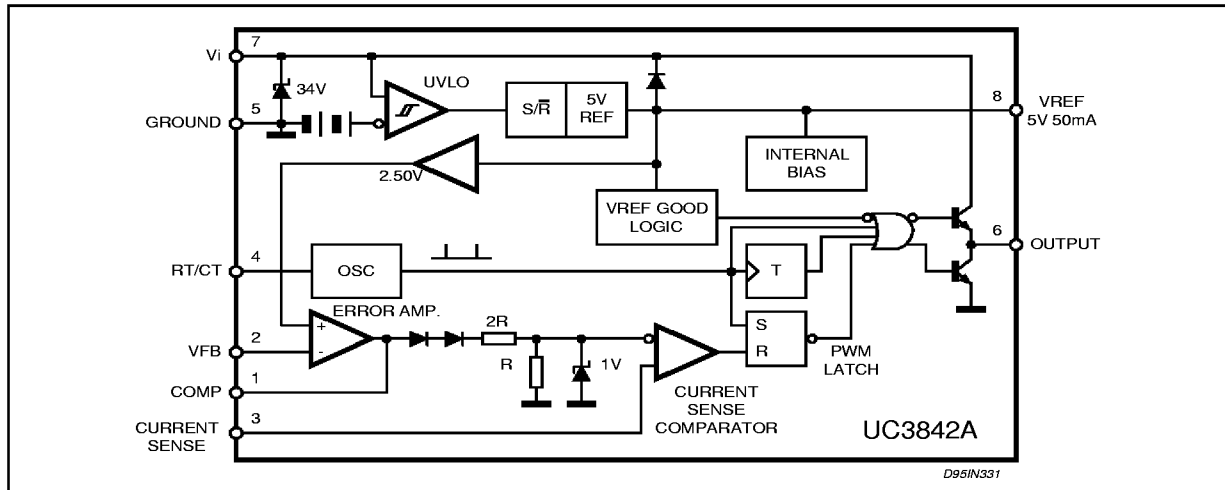

UC2842A/3A/4A/5A - UC3842A/3A/4A/5A

ABSOLUTE MAXIMUM RATINGS

Symbol	Parameter	Value	Unit
V_i	Supply Voltage (low impedance source)	30	V
V_i	Supply Voltage ($I_i < 30\text{mA}$)	Self Limiting	
I_o	Output Current	± 1	A
E_o	Output Energy (capacitive load)	5	μJ
	Analog Inputs (pins 2, 3)	- 0.3 to 5.5	V
	Error Amplifier Output Sink Current	10	mA
P_{tot}	Power Dissipation at $T_{\text{amb}} \leq 25^\circ\text{C}$ (Minidip)	1.25	W
P_{tot}	Power Dissipation at $T_{\text{amb}} \leq 25^\circ\text{C}$ (SO8)	800	mW
T_{stg}	Storage Temperature Range	- 65 to 150	$^\circ\text{C}$
T_L	Lead Temperature (soldering 10s)	300	$^\circ\text{C}$

* All voltages are with respect to pin 5, all currents are positive into the specified terminal.

PIN CONNECTION (top view)

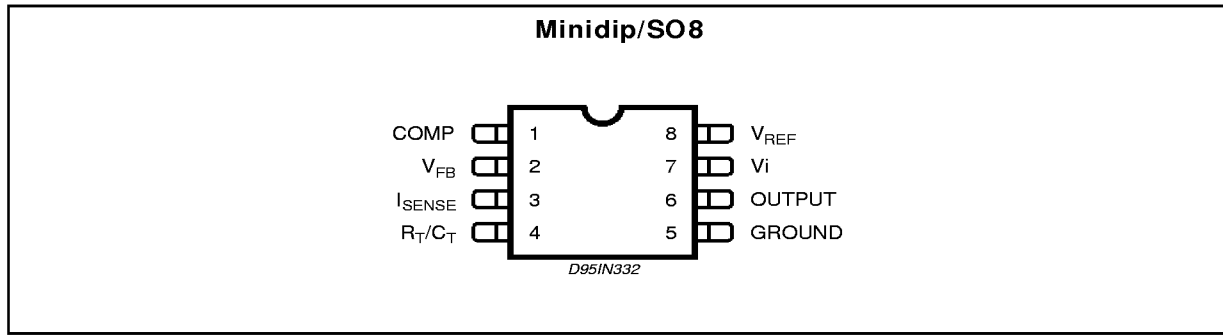

PIN FUNCTIONS

No	Function	Description
1	COMP	This pin is the Error Amplifier output and is made available for loop compensation.
2	V_{FB}	This is the inverting input of the Error Amplifier. It is normally connected to the switching power supply output through a resistor divider.
3	I_{SENSE}	A voltage proportional to inductor current is connected to this input. The PWM uses this information to terminate the output switch conduction.
4	R_T/C_T	The oscillator frequency and maximum Output duty cycle are programmed by connecting resistor R_T to V_{ref} and capacitor C_T to ground. Operation to 500kHz is possible.
5	GROUND	This pin is the combined control circuitry and power ground.
6	OUTPUT	This output directly drives the gate of a power MOSFET. Peak currents up to 1A are sourced and sunk by this pin.
7	V_{CC}	This pin is the positive supply of the control IC.
8	V_{ref}	This is the reference output. It provides charging current for capacitor C_T through resistor R_T .

ORDERING NUMBERS

SO8	Minidip
UC2842AD1; UC3842AD1	UC2842AN; UC3842AN
UC2843AD1; UC3843AD1	UC2843AN; UC3843AN
UC2844AD1; UC3844AD1	UC2844AN; UC3844AN
UC2845AD1; UC3845AD1	UC2845AN; UC3845AN

THERMAL DATA

Symbol	Description	Minidip	SO8	Unit
$R_{thj-amb}$	Thermal Resistance Junction-ambient. max.	100	150	°C/W

ELECTRICAL CHARACTERISTICS ([note 1] Unless otherwise stated, these specifications apply for $-25 \leq T_{amb} \leq 85^{\circ}\text{C}$ for UC284XA; $0 \leq T_{amb} \leq 70^{\circ}\text{C}$ for UC384XA; $V_i = 15\text{V}$ (note 5); $R_T = 10\text{K}$; $C_T = 3.3\text{nF}$)

Symbol	Parameter	Test Conditions	UC284XA			UC384XA			Unit
			Min.	Typ.	Max.	Min.	Typ.	Max.	
REFERENCE SECTION									
V_{REF}	Output Voltage	$T_j = 25^{\circ}\text{C}$ $I_o = 1\text{mA}$	4.95	5.00	5.05	4.90	5.00	5.10	V
ΔV_{REF}	Line Regulation	$12\text{V} \leq V_i \leq 25\text{V}$		2	20		2	20	mV
ΔV_{REF}	Load Regulation	$1 \leq I_o \leq 20\text{mA}$		3	25		3	25	mV
$\Delta V_{REF}/\Delta T$	Temperature Stability	(Note 2)		0.2			0.2		mV/°C
	Total Output Variation	Line, Load, Temperature	4.9		5.1	4.82		5.18	V
e_N	Output Noise Voltage	$10\text{Hz} \leq f \leq 10\text{KHz}$ $T_j = 25^{\circ}\text{C}$ (note 2)		50			50		μV
	Long Term Stability	$T_{amb} = 125^{\circ}\text{C}$, 1000Hrs (note 2)		5	25		5	25	mV
I_{SC}	Output Short Circuit		-30	-100	-180	-30	-100	-180	mA
OSCILLATOR SECTION									
f_{OSC}	Frequency	$T_j = 25^{\circ}\text{C}$	47	52	57	47	52	57	KHz
$\Delta f_{OSC}/\Delta V$	Frequency Change with Volt.	$V_{CC} = 12\text{V}$ to 25V	-	0.2	1	-	0.2	1	%
$\Delta f_{OSC}/\Delta T$	Frequency Change with Temp.	$T_A = T_{low}$ to T_{high}	-	5	-	-	5	-	%
V_{OSC}	Oscillator Voltage Swing	(peak to peak)	-	1.6	-	-	1.6	-	V
I_{dischg}	Discharge Current ($V_{OSC} = 2\text{V}$)	$T_j = 25^{\circ}\text{C}$	7.8	8.3	8.8	7.8	8.3	8.8	mA
ERROR AMP SECTION									
V_2	Input Voltage	$V_{PIN1} = 2.5\text{V}$	2.45	2.50	2.55	2.42	2.50	2.58	V
I_b	Input Bias Current	$V_{FB} = 5\text{V}$		-0.1	-1		-0.1	-2	μA
	A_{VOL}	$2\text{V} \leq V_o \leq 4\text{V}$	65	90		65	90		dB
BW	Unity Gain Bandwidth	$T_j = 25^{\circ}\text{C}$	0.7	1		0.7	1		MHz
PSRR	Power Supply Rejec. Ratio	$12\text{V} \leq V_i \leq 25\text{V}$	60	70		60	70		dB
I_o	Output Sink Current	$V_{PIN2} = 2.7\text{V}$ $V_{PIN1} = 1.1\text{V}$	2	12		2	12		mA
I_o	Output Source Current	$V_{PIN2} = 2.3\text{V}$ $V_{PIN1} = 5\text{V}$	-0.5	-1		-0.5	-1		mA
	V_{OUT} High	$V_{PIN2} = 2.3\text{V}$; $R_L = 15\text{K}\Omega$ to Ground	5	6.2		5	6.2		V
	V_{OUT} Low	$V_{PIN2} = 2.7\text{V}$; $R_L = 15\text{K}\Omega$ to Pin 8		0.8	1.1		0.8	1.1	V
CURRENT SENSE SECTION									
G_V	Gain	(note 3 & 4)	2.85	3	3.15	2.85	3	3.15	V/V
V_3	Maximum Input Signal	$V_{PIN1} = 5\text{V}$ (note 3)	0.9	1	1.1	0.9	1	1.1	V
SVR	Supply Voltage Rejection	$12 \leq V_i \leq 25\text{V}$ (note 3)		70			70		dB
I_b	Input Bias Current			-2	-10		-2	-10	μA
	Delay to Output			150	300		150	300	ns

UC2842A/3A/4A/5A - UC3842A/3A/4A/5A

ELECTRICAL CHARACTERISTICS (continued)

Symbol	Parameter	Test Conditions	UC284XA			UC384XA			Unit
			Min.	Typ.	Max.	Min.	Typ.	Max.	
OUTPUT SECTION									
V _{OL}	Output Low Level	I _{SINK} = 20mA		0.1	0.4		0.1	0.4	V
		I _{SINK} = 200mA		1.6	2.2		1.6	2.2	V
V _{OH}	Output High Level	I _{SOURCE} = 20mA	13	13.5		13	13.5		V
		I _{SOURCE} = 200mA	12	13.5		12	13.5		V
V _{OLS}	UVLO Saturation	V _{CC} = 6V; I _{SINK} = 1mA		0.7	1.2		0.7	1.2	V
t _r	Rise Time	T _j = 25°C C _L = 1nF (2)		50	150		50	150	ns
t _f	Fall Time	T _j = 25°C C _L = 1nF (2)		50	150		50	150	ns
UNDER-VOLTAGE LOCKOUT SECTION									
	Start Threshold	X842A/4A	15	16	17	14.5	16	17.5	V
		X843A/5A	7.8	8.4	9.0	7.8	8.4	9.0	V
	Min Operating Voltage After Turn-on	X842A/4A	9	10	11	8.5	10	11.5	V
		X843A/5A	7.0	7.6	8.2	7.0	7.6	8.2	V
PWM SECTION									
	Maximum Duty Cycle	X842A/3A	94	96	100	94	96	100	%
		X844A/5A	47	48	50	47	48	50	%
	Minimum Duty Cycle			0			0	%	
TOTAL STANDBY CURRENT									
I _{st}	Start-up Current	V _i = 6.5V for UCX843A/45A		0.3	0.5		0.3	0.5	mA
		V _i = 14V for UCX842A/44A		0.3	0.5		0.3	0.5	mA
I _i	Operating Supply Current	V _{PIN2} = V _{PIN3} = 0V		12	17		12	17	mA
V _{iz}	Zener Voltage	I _i = 25mA	30	36		30	36		V

- Notes :**
1. Max package power dissipation limits must be respected; low duty cycle pulse techniques are used during test maintain T_j as close to T_{amb} as possible.
 2. These parameters, although guaranteed, are not 100% tested in production.
 3. Parameter measured at trip point of latch with V_{PIN2} = 0.
 4. Gain defined as :

$$A = \frac{\Delta V_{PIN1}}{\Delta V_{PIN3}} ; 0 \leq V_{PIN3} \leq 0.8V$$
 5. Adjust V_i above the start threshold before setting at 15 V.

Figure 1: Open Loop Test Circuit.

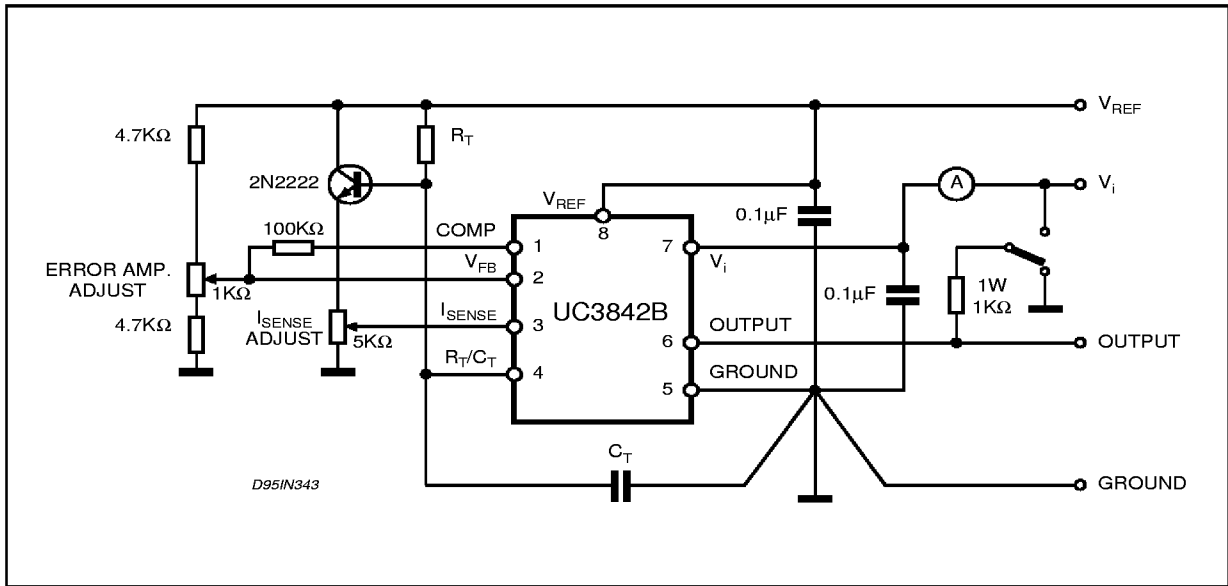

High peak currents associated with capacitive loads necessitate careful grounding techniques. Timing and bypass capacitors should be connected close

to pin 5 in a single point ground. The transistor and 5 KΩ potentiometer are used to sample the oscillator waveform and apply an adjustable ramp to pin 3.

Figure 2: Oscillator Frequency vs Timing Resistance

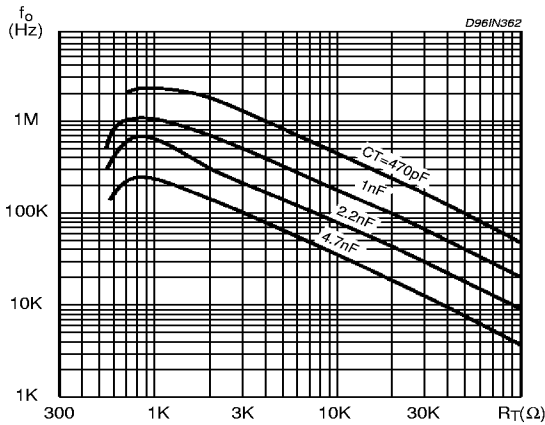

Figure 3: Maximum Duty Cycle vs Timing Resistance

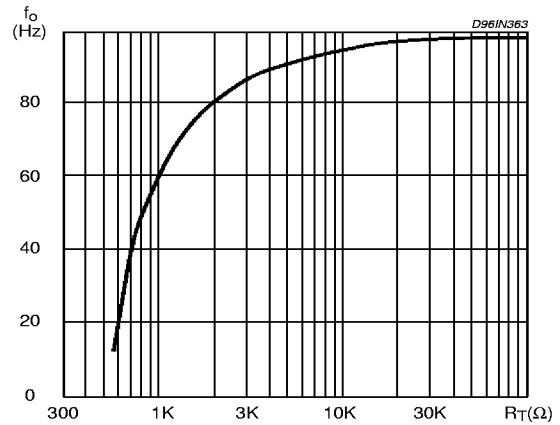

Figure 4: Oscillator Discharge Current vs. Temperature.

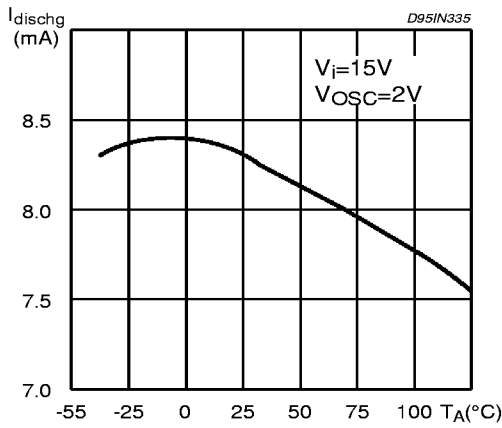

Figure 5: Error Amp Open-Loop Gain and Phase vs. Frequency.

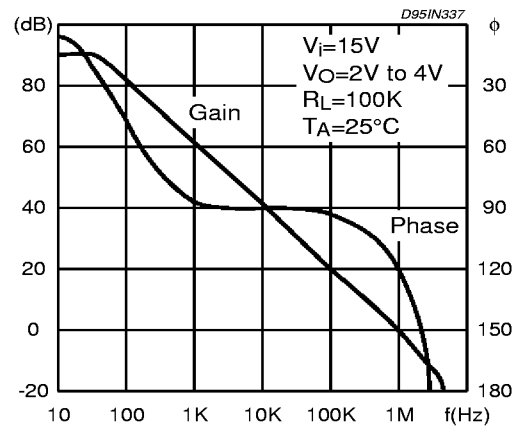

Figure 6: Current Sense Input Threshold vs. Error Amp Output Voltage.

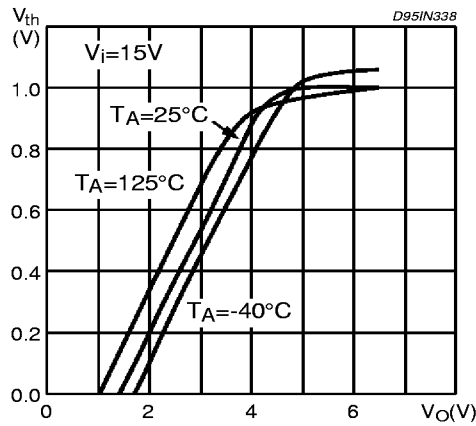

Figure 7: Reference Voltage Change vs. Source Current.

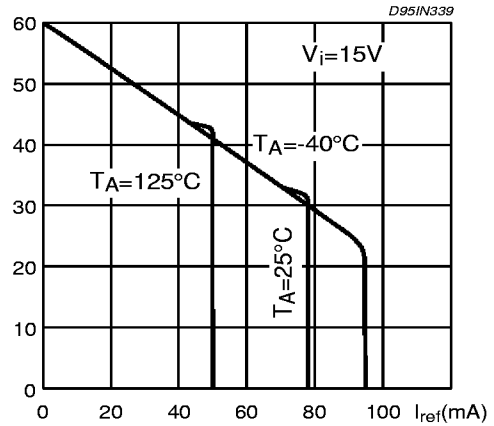

Figure 8: Reference Short Circuit Current vs. Temperature.

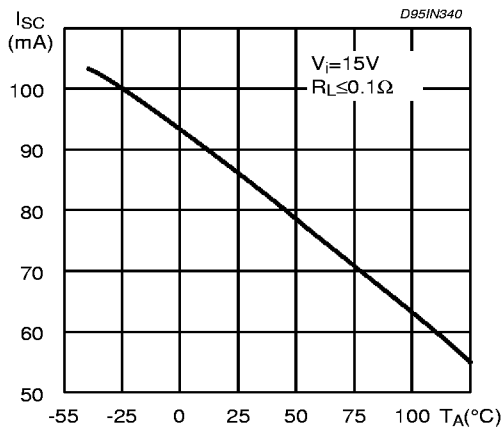

Figure 9: Output Saturation Voltage vs. Load Current.

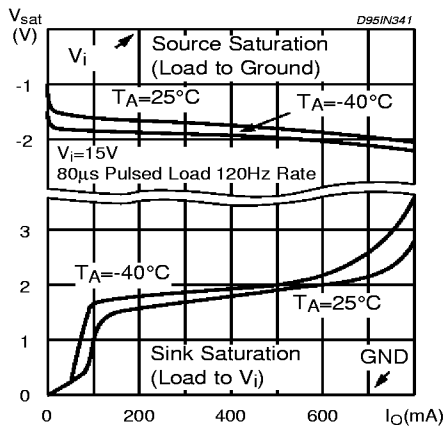

Figure 11: Output Waveform.

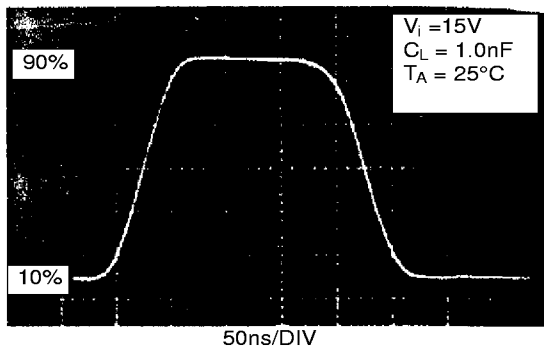

Figure 10: Supply Current vs. Supply Voltage.

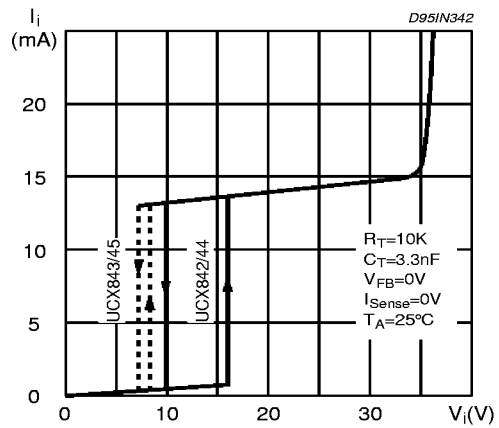

Figure 12: Output Cross Conduction

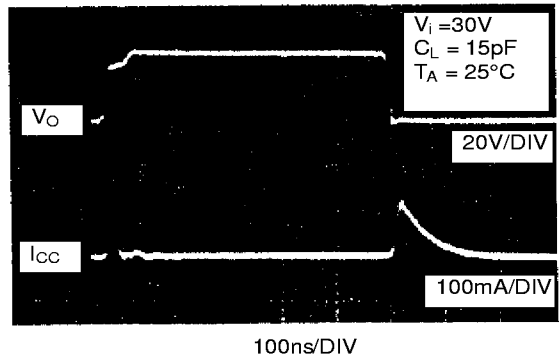

Figure 13: Oscillator and Output Waveforms.

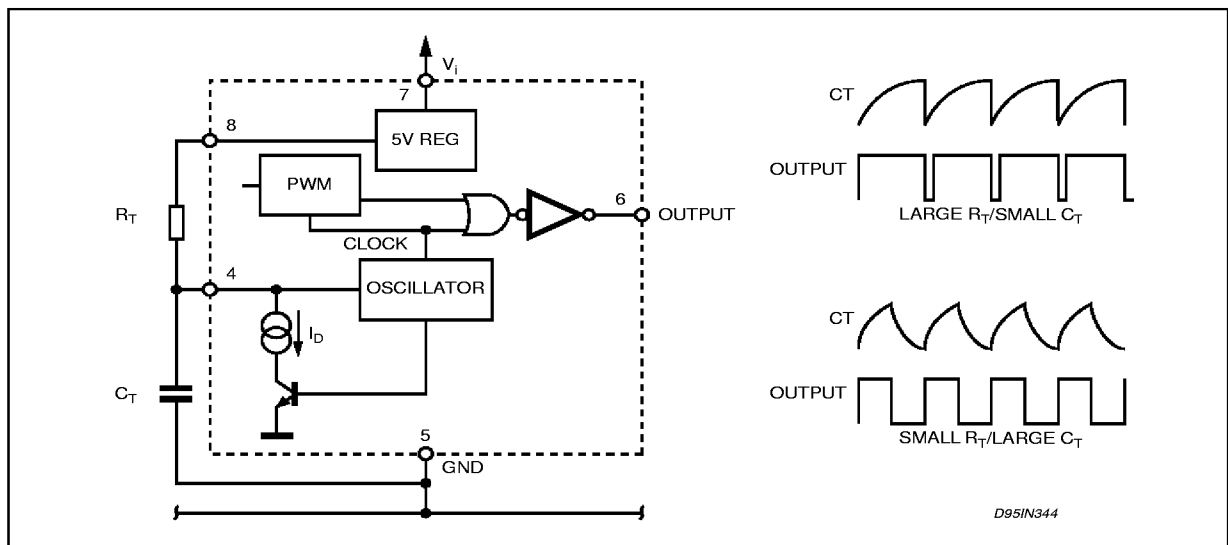

Figure 14 : Error Amp Configuration.

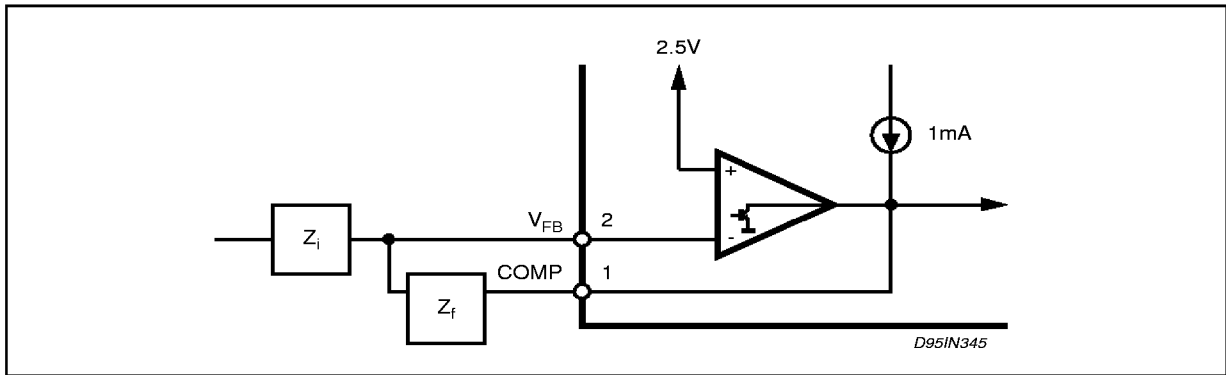

Figure 15 : Under Voltage Lockout.

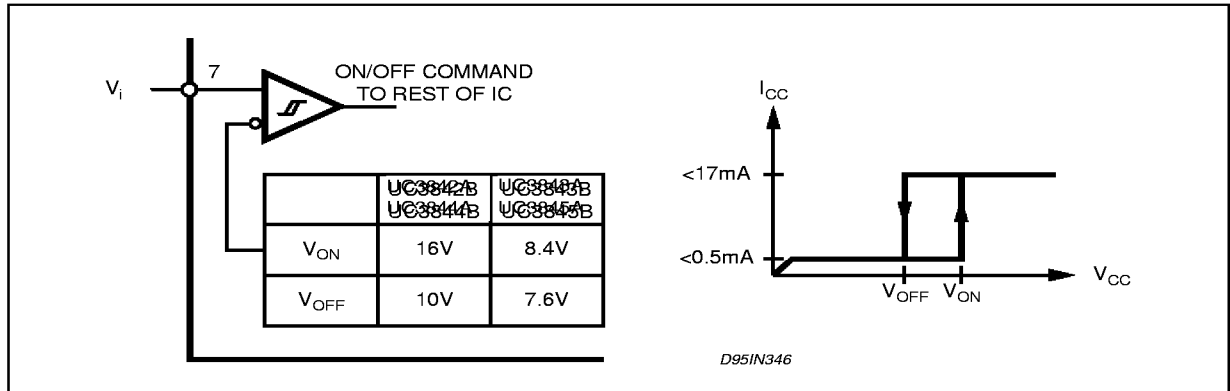
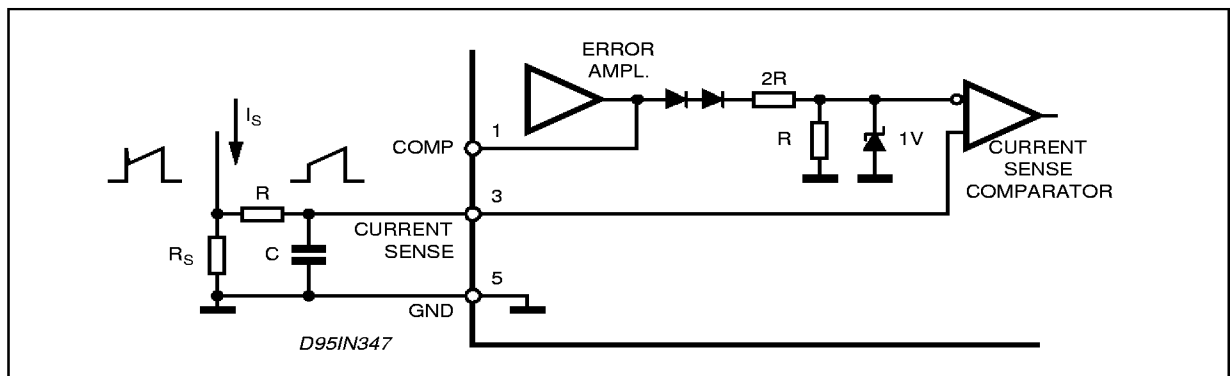

Figure 16 : Current Sense Circuit .



Peak current (I_s) is determined by the formula

$$I_{s \max} \approx \frac{1.0 \text{ V}}{R_s}$$

A small RC filter may be required to suppress switch transients.

Figure 17 : Slope Compensation Techniques.

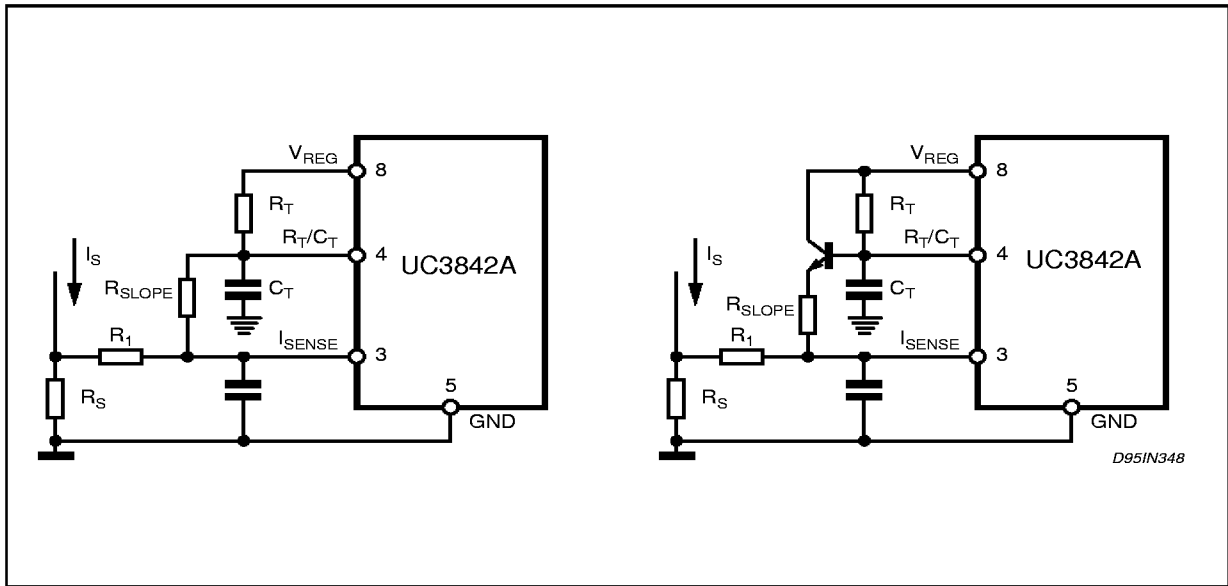

Figure 18 : Isolated MOSFET Drive and Current Transformer Sensing.

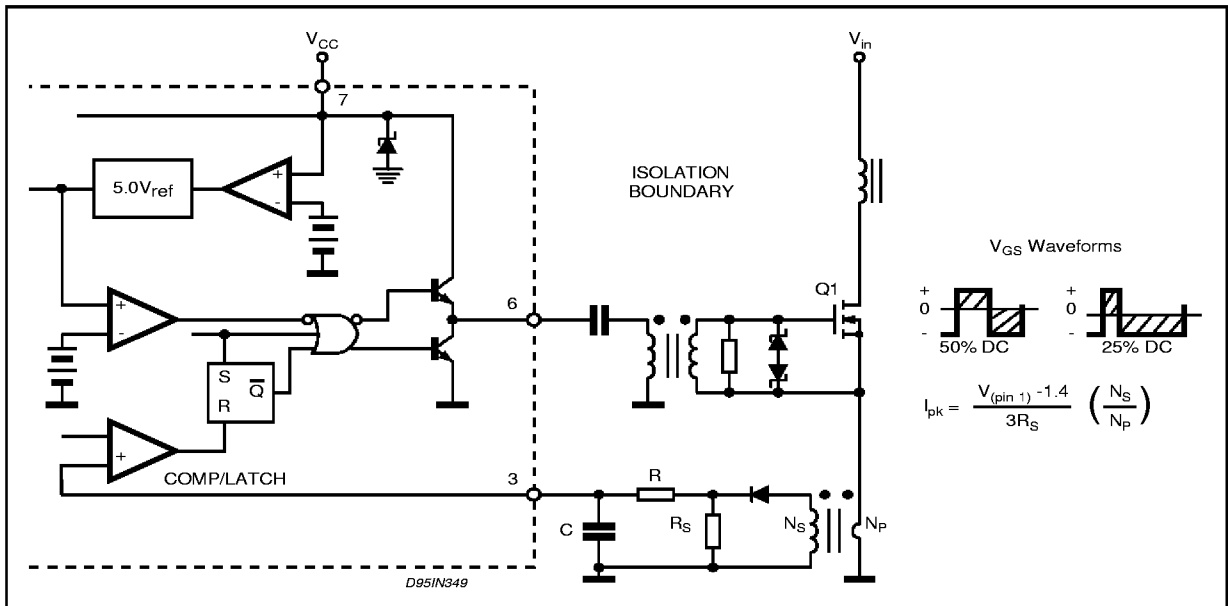

Figure 19 : Latched Shutdown.

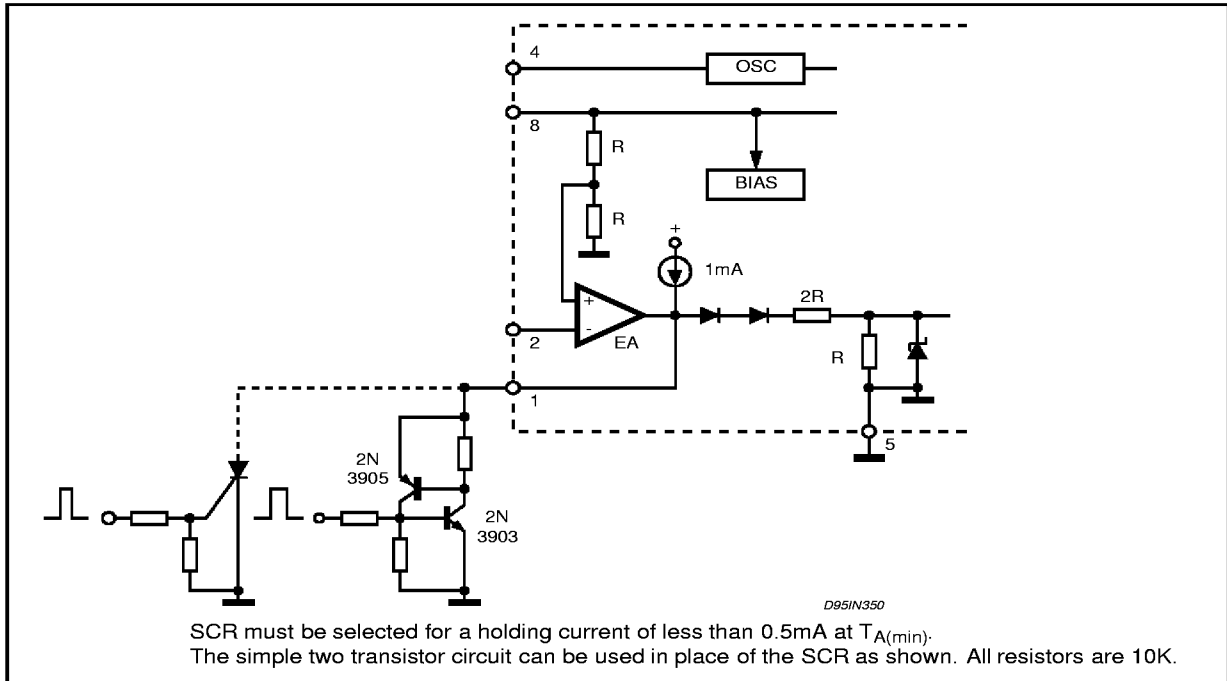

Figure 20: Error Amplifier Compensation

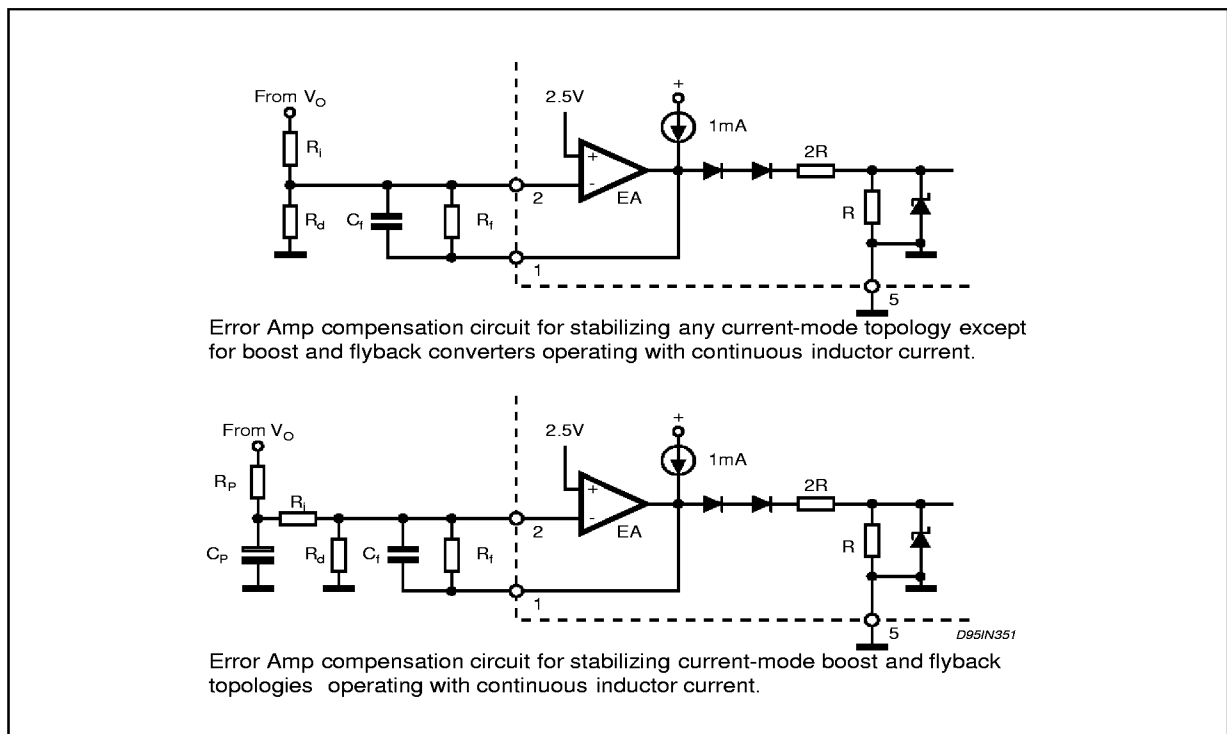

Figure 21: External Clock Synchronization.

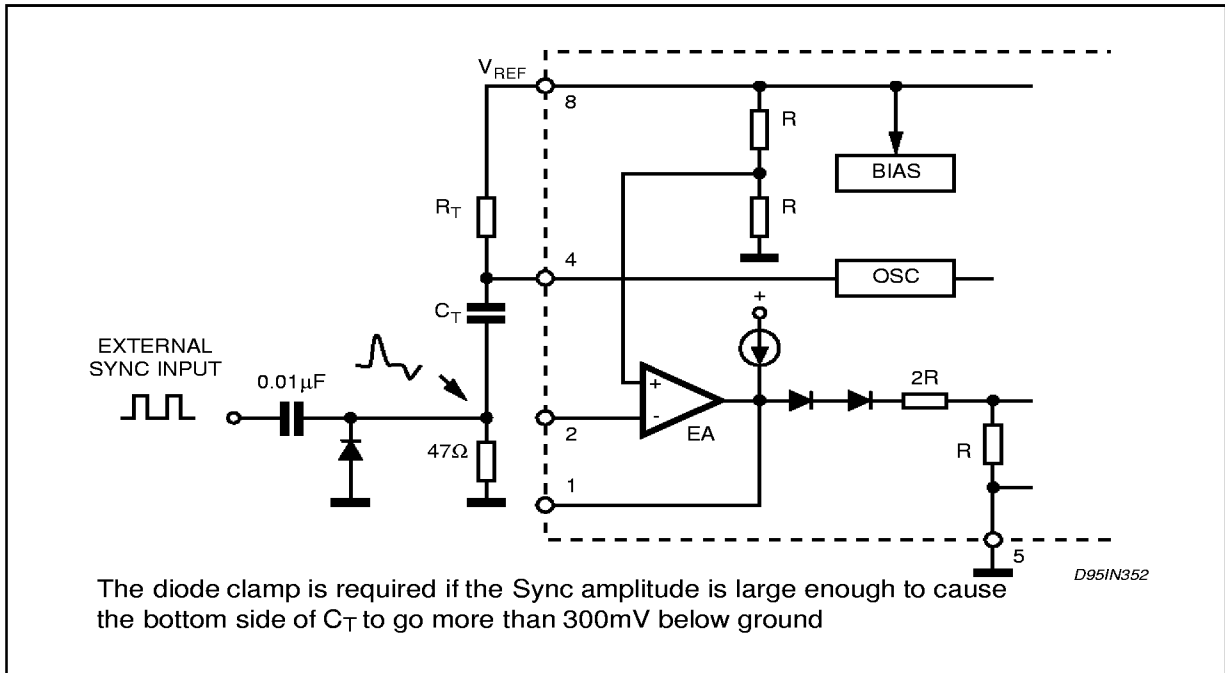

Figure 22: External Duty Cycle Clamp and Multi Unit Synchronization.

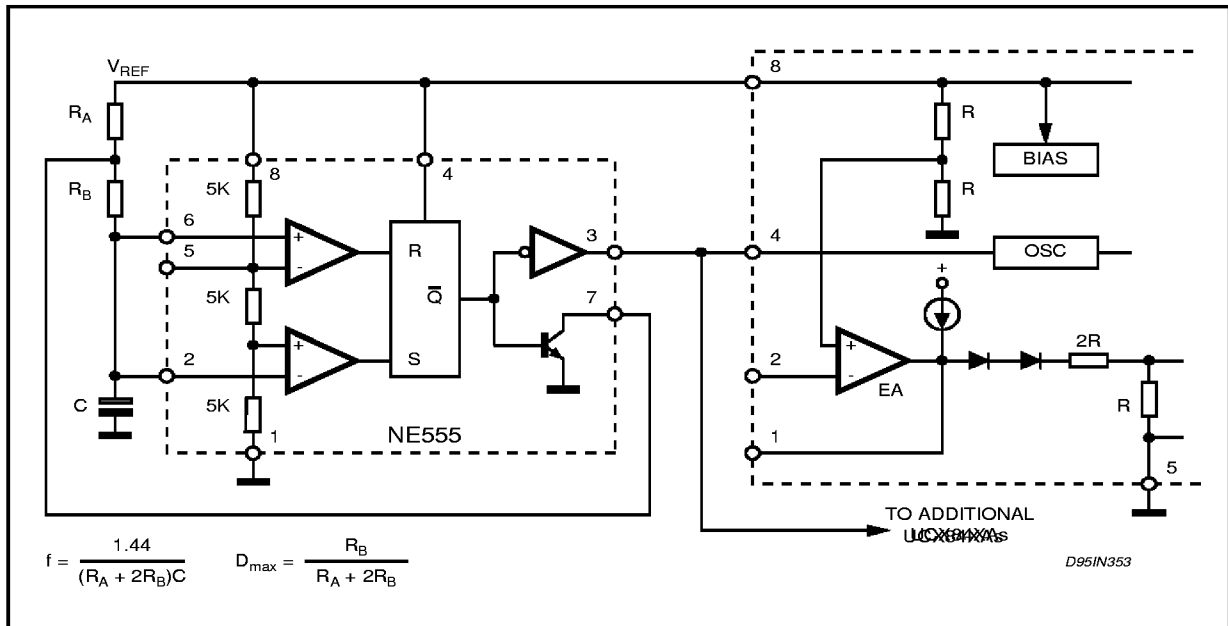

Figure 23: Soft-Start Circuit

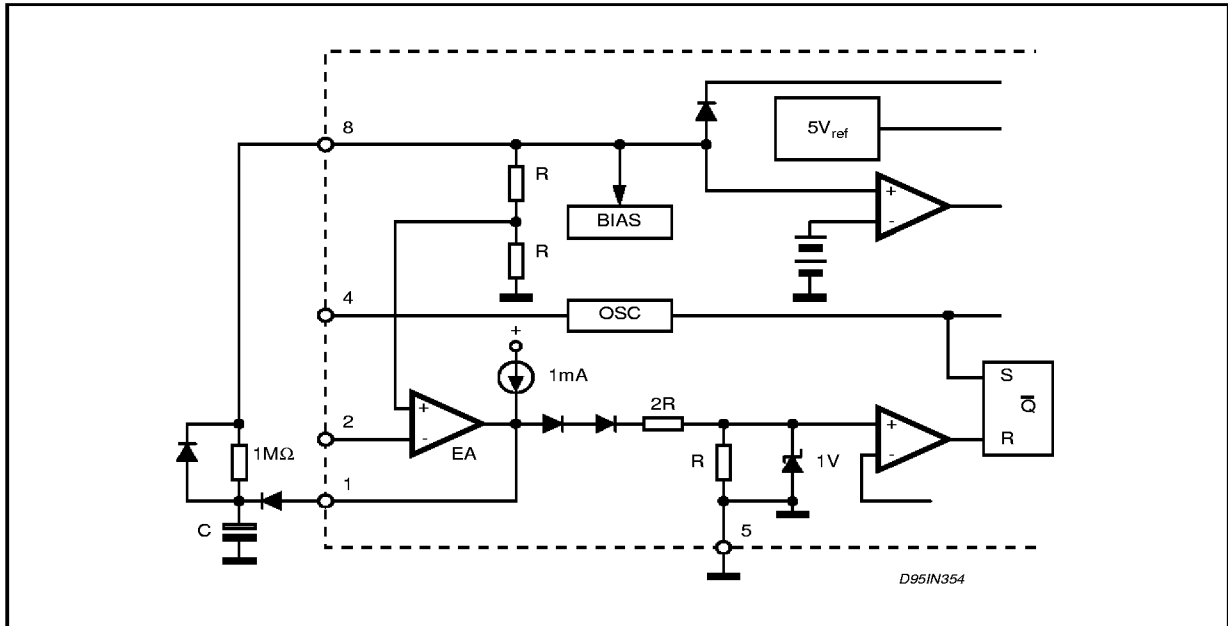
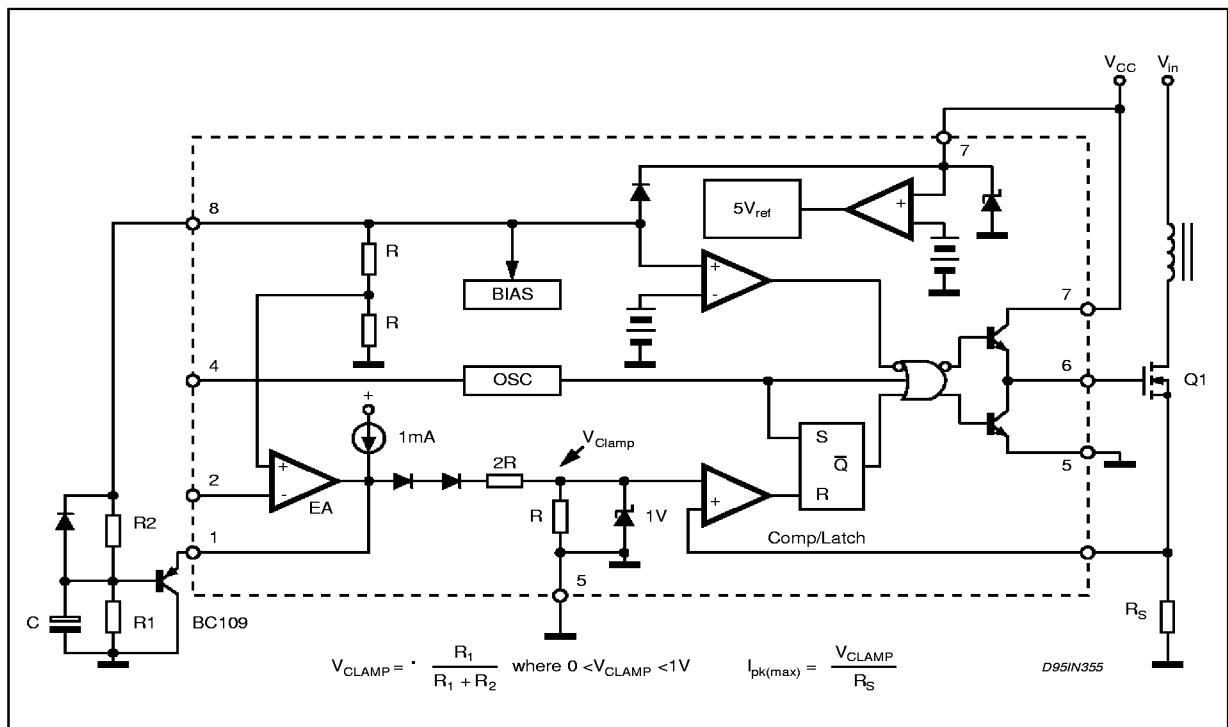
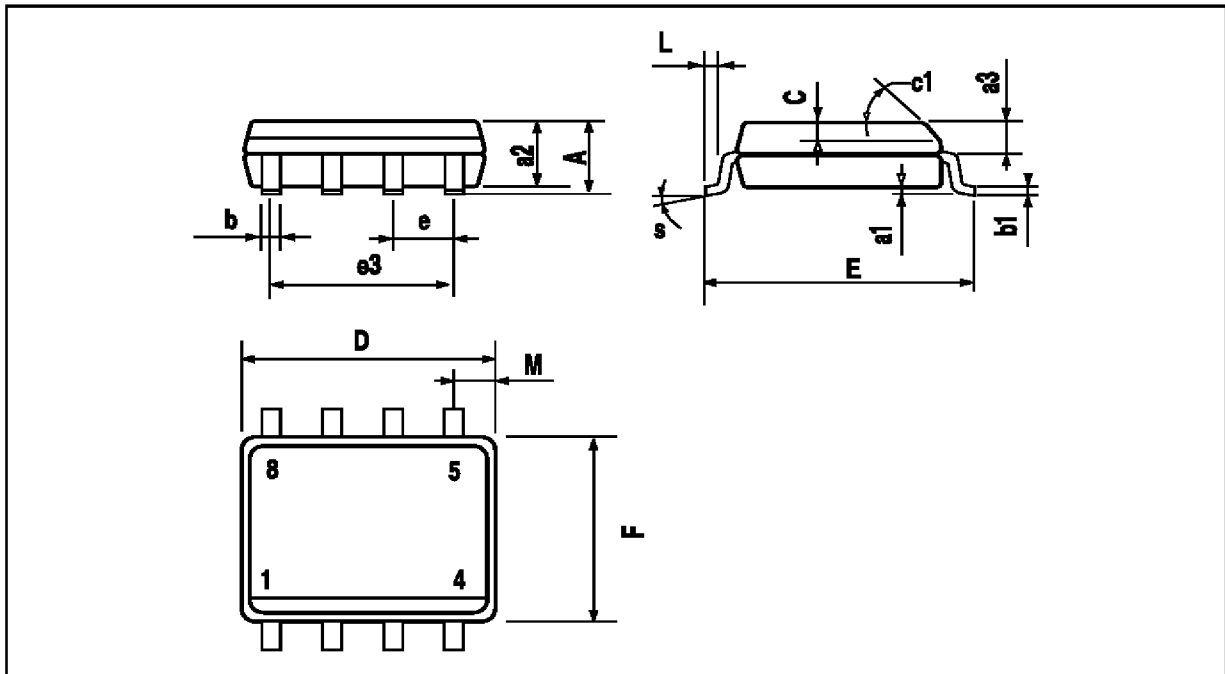

Figure 24: Soft-Start and Error Amplifier Output Duty Cycle Clamp.



SO8 PACKAGE MECHANICAL DATA

DIM.	mm			Inch		
	MIN.	TYP.	MAX.	MIN.	TYP.	MAX.
A			1.75			0.069
a1	0.1		0.25	0.004		0.010
a2			1.6			0.063
a3	0.65		0.85	0.026		0.033
b	0.35		0.48	0.014		0.019
b1	0.19		0.25	0.007		0.010
C		0.25	0.5	0.010		0.020
c1	45 (typ.)					
D	4.8		5.0	0.189		0.197
E	5.8		6.2	0.228		0.244
e		1.27			0.050	
e3		3.81			0.150	
F	3.8		4.0	0.15		0.157
L	0.4		1.27	0.016		0.050
M			0.6			0.024
S	8 (max.)					



UC2842A/3A/4A/5A - UC3842A/3A/4A/5A

MINIDIP PACKAGE MECHANICAL DATA

DIM.	mm			Inch		
	MIN.	TYP.	MAX.	MIN.	TYP.	MAX.
A		3.32			0.131	
a1	0.51			0.020		
B	1.15		1.65	0.045		0.065
b	0.356		0.55	0.014		0.022
b1	0.204		0.304	0.008		0.012
D			10.92			0.430
E	7.95		9.75	0.313		0.384
e		2.54			0.100	
e3		7.62			0.300	
e4		7.62			0.300	
F			6.6			0.260
I			5.08			0.200
L	3.18		3.81	0.125		0.150

