

ISO 9141 INTERFACE

- OPERATING POWER SUPPLY VOLTAGE RANGE $4.5V \leq V_s \leq 36V$ (40V FOR TRANSIENTS)
- REVERSE SUPPLY (BATTERY) PROTECTED DOWN TO $V_s \geq -24V$
- STANDBY MODE WITH VERY LOW CURRENT CONSUMPTION $I_{S_{SB}} 1\mu A @ V_{CC} 0.5V$
- LOW QUIESCENT CURRENT IN OFF CONDITION $I_{S_{OFF}} = 120\mu A$
- TTL COMPATIBLE TX INPUT
- BIDIRECTIONAL K-I/O PIN WITH SUPPLY VOLTAGE DEPENDENT INPUT THRESHOLD
- OVERTEMPERATURE SHUT DOWN FUNCTION SELECTIVE TO K-I/O PIN
- WIDE INPUT AND OUTPUT VOLTAGE RANGE $-24V \leq V_k \leq V_s$
- K OUTPUT CURRENT LIMITATION, TYP $I_k = 60mA$
- DEFINED OFF OUTPUT STATUS IN UNDERVOLTAGE CONDITION AND V_s OR GND INTERRUPTION
- CONTROLLED OUTPUT SLOPE FOR LOW EMI
- HIGH INPUT IMPEDANCE FOR OPEN V_s OR GND CONNECTION

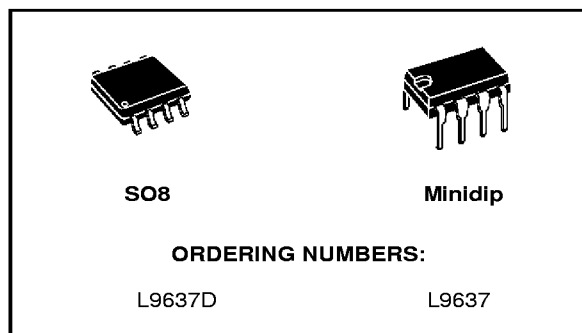

- DEFINED OUTPUT ON STATUS OF LO OR RX FOR OPEN LI OR K INPUTS
- DEFINED K OUTPUT OFF FOR TX INPUT OPEN
- INTEGRATED PULL UP RESISTORS FOR TX, RX AND LO
- EMI ROBUSTNESS OPTIMIZED

DESCRIPTION

The L9637 is a monolithic integrated circuit containing standard ISO 9141 compatible interface functions.

BLOCK DIAGRAM

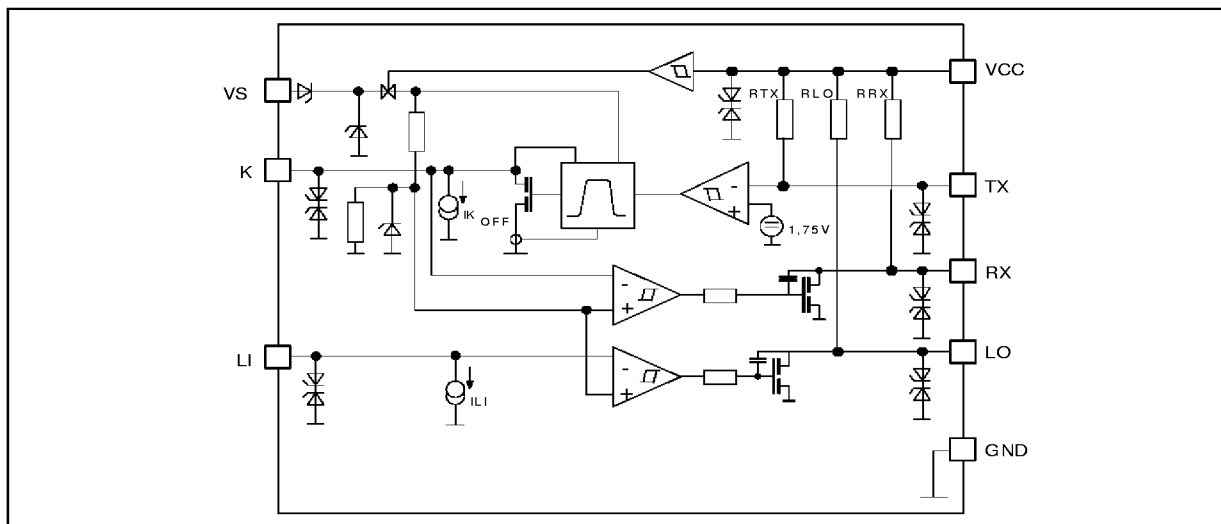

L9637

ABSOLUTE MAXIMUM RATINGS (No damage or latch)

Symbol	Parameter	Value	Unit
V_S	Supply Voltage	-24 to +36	V
	ISO transients $t = 400\text{ms}$	-24 to +40	V
V_{CC}	Stabilized Voltage	-24 to +7	V
$\Delta V_S/dt$	Supply Voltage transient	-10 to +10	V/ μs
$V_{LI,K}$	Pin Voltage	-24 to V_S	V
$V_{LO,RX,TX}$	Pin Voltage	-24 to V_{CC}	V

Note: Max. ESD voltages are $\pm 2\text{kV}$ with human body model $C = 100\text{pF}$, $R = 1.5\text{k}$ corresponds to maximum energy dissipation 0.2mJ according to MIL883C.

PIN CONNECTION (Top view)

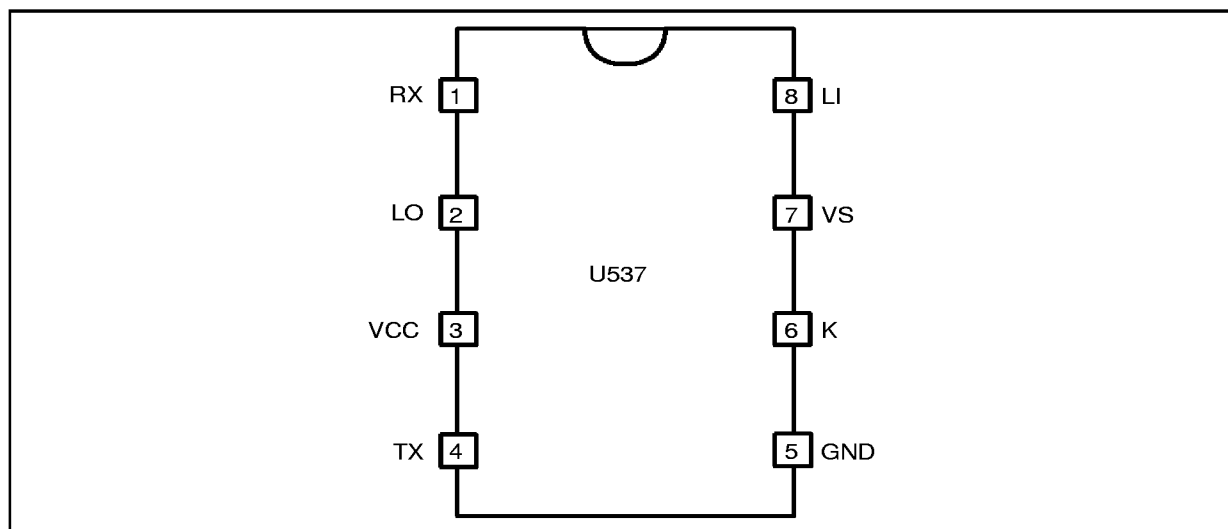

THERMAL DATA

Symbol	Parameter	Min.	Typ.	Max.	Unit
T_{JSDon}	Temperature K shutdown switch on threshold	160		200	$^{\circ}\text{C}$
T_{JSDoff}	Temperature K shutdown switch off threshold	150		200	$^{\circ}\text{C}$
$R_{th\ j-amb}$	Thermal steady state junction to ambient resistance for SO8	130	155	180	$^{\circ}\text{C/W}$
	Thermal steady state junction to ambient resistance for Minidip	80	100	120	$^{\circ}\text{C/W}$

PIN DESCRIPTION

N.	Name	Function
1	RX	Output for K as input
2	LO	Output L comparator
3	VCC	Stabilized voltage supply
4	TX	Input for K as output
5	GND	Common GND
6	K	Bidirectional I/O
7	VS	Supply voltage
8	LI	Input L comparator

ELECTRICAL CHARACTERISTICS (The electrical characteristics are valid within the below defined operating conditions, unless otherwise specified. The function is guaranteed by design until T_{JSDon} temperature shutdown switch-on-threshold.)

Symbol	Parameter	Test Condition	Min.	Typ.	Max.	Unit
V_S	Supply Voltage		4.5		36	V
V_{CC}	Stabilized Voltage		3		7	V
T_j	Junction temperature		40		150	°C
I_{CC}	Supply V_{CC} Current	$V_{CC} \leq 5.5V$; $V_{LI}, V_{TX} = 0V$		1.4	2.3	mA
		$V_K \geq V_{Khigh}$; $V_{LI} \geq V_{LIhigh}$ $V_{TX} = V_{CC}$ @ $V_{CC} \leq 5.5V$	-5	<1	5	μA
I_{SON}	Supply V_S Current	$V_S \leq 16V$; $V_{LI}, V_{TX} = 0V$		1.2	3	mA
I_{SOFF}		$V_K \geq V_{Khigh}$; $V_{LI} \geq V_{LIhigh}$ $V_{TX} \geq V_{TXhigh}$ @ $V_S \leq 12V$		120	220	μA
I_{SSB}		$V_{CC} \leq 0.5V$ @ $V_S \leq 12V$		<1		μA
V_{Klow}	Input Voltage Low state	RX output status LOW $4.5V \leq V_S \leq 18V$	-24		$0.45V_S$	V
		RX output status LOW $18V < V_S$	-24		8	V
V_{Khigh}	Input Voltage High state	RX output status HIGH $4.5V \leq V_S \leq 18V$	$0.55V_S$		V_S	V
		RX output status HIGH $18V < V_S$	12		V_S	V
V_{Khys}	Input Threshold Hysteresis	$V_{Khigh} - V_{Klow}$		$0.025V_S$	0.8	V
I_{Koff}	Input Current	@ $V_{TX} \geq V_{TXhigh}$ $V_K \leq V_S$ $V_S, V_{CC} \geq 0$ or $V_S, V_{CC} = open$	-5	4	25	μA
R_{KON}	Output ON Impedance	@ $V_S \geq 6.5V$ $V_{TX} \leq V_{TXlow}$ $I_k \geq 7mA$ 1)		10	30	Ω
I_{KSC}	Short Circuit Current		30	60	100	mA
V_{TXlow}	Input voltage LOW state		-24		1	V
V_{TXhigh}	Input voltage HIGH state		2.5		V_{CC}	V
R_{RXON} R_{LOON}	Output ON Impedance	$V_K \leq V_{Klow}$; $V_{LI} \leq V_{LIlow}$ $V_S \geq 6.5V$ $I_{RX, LO} \geq 350\mu A$ 1)		40	90	Ω
I_{RXSC} I_{LOSC}	Output Short Circuit Current		9	20	35	mA
V_{RXH} V_{LOH}	Output Voltage HIGH state	$10M\Omega \leq R_{LRX}$ $10M\Omega \leq R_{LLO}$	$V_{CC} - 0.25$	$V_{CC} - 0.1$	V_{CC}	V
R_{LO} R_{RX}	Output pull-up resistance	Output status = (HIGH) $-0.15V \leq V_{LO} \leq V_{CC} + 0.15V$ $-0.15V \leq V_{RX} \leq V_{CC} + 0.15V$	5	10	20	$K\Omega$
R_{TX}	Input pull up resistance	$-0.15V \leq V_{TX} \leq V_{CC} + 0.15V$	10	20	40	$K\Omega$
V_{Llow}	Input voltage LOW state	LO output status LOW $4.5V \leq V_S \leq 18V$	-24		$0.45V_S$	V
		LO output status LOW $18V < V_S$	-24		8	V
V_{Lhigh}	Input voltage HIGH state	LO output status HIGH $4.5V \leq V_S \leq 18V$	$0.55V_S$		V_S	V
		LO output status HIGH $18V < V_S$	12		V_S	V
V_{Lhys}	Input threshold hysteresis	$V_{Lhigh} - V_{Llow}$		$0.025V_S$	0.8	V
I_{LI}	Input current	$V_{LI} \leq V_S$ $V_S, V_{CC} \geq 0$ or $V_S, V_{CC} = open$	-5	4	25	μA

ELECTRICAL CHARACTERISTIC (continued)

Symbol	Parameter	Test Condition	Min.	Typ.	Max.	Unit
$C_{KI, LO, RX}$	Internal output capacities				20	pF
f_{LI-LO} f_{K-RX} f_{TX-K}	Transmission Frequency	$9V < V_S < 16V$ (external loads) $R_{KO} = 510\Omega$, $C_K \leq 1.3nF$ in active mode see Fig. 3	50	100		kHz
t_{rLI-LO} t_{rK-RX} t_{rTX-K}	Rise Time	for the definition of t_r , t_f see Fig.1.		2	6	μs
t_{fLI-LO} t_{fK-RX} t_{fTX-K}	Fall Time	$9V < V_S < 16V$ (external loads) $R_{KO} = 510\Omega$, $C_K \leq 1.3nF$		2	6	μs
$t_{OFF, LI-LO}$ $t_{OFF, K-RX}$ $t_{OFF, TX-K}$	Switch OFF time	for the definition of t_{ON} , t_{OFF} see Fig.1.		4	17	μs
$t_{ON, LI-LO}$ $t_{ON, K-RX}$ $t_{ON, TX-K}$	Switch ON time	$9V < V_S < 16V$ (external loads) $R_{KO} = 510\Omega$, $C_K \leq 1.3nF$ (inactive mode see Fig. 3)		4	17	μs

1) For output currents lower than this value a series protection diode can become active. See also Fig. 4 and 5.

Figure 1: Input to Output Timings and Output Pulse Shape.

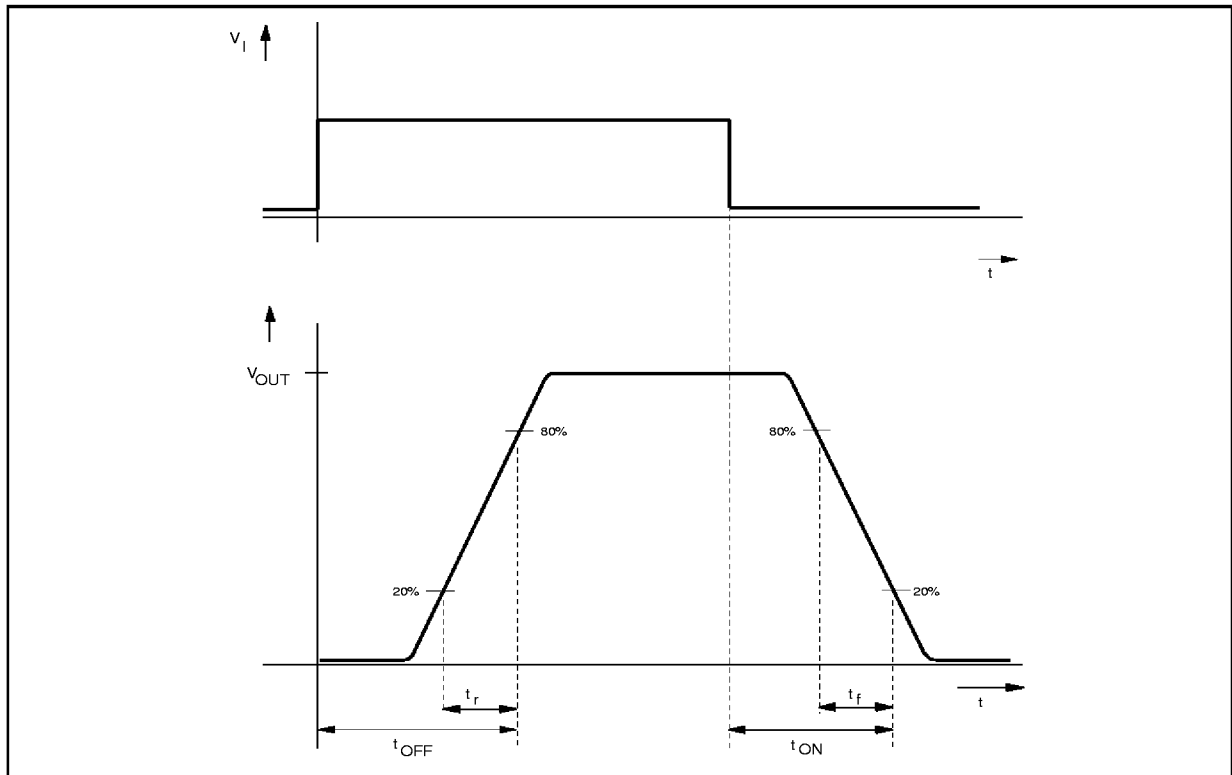
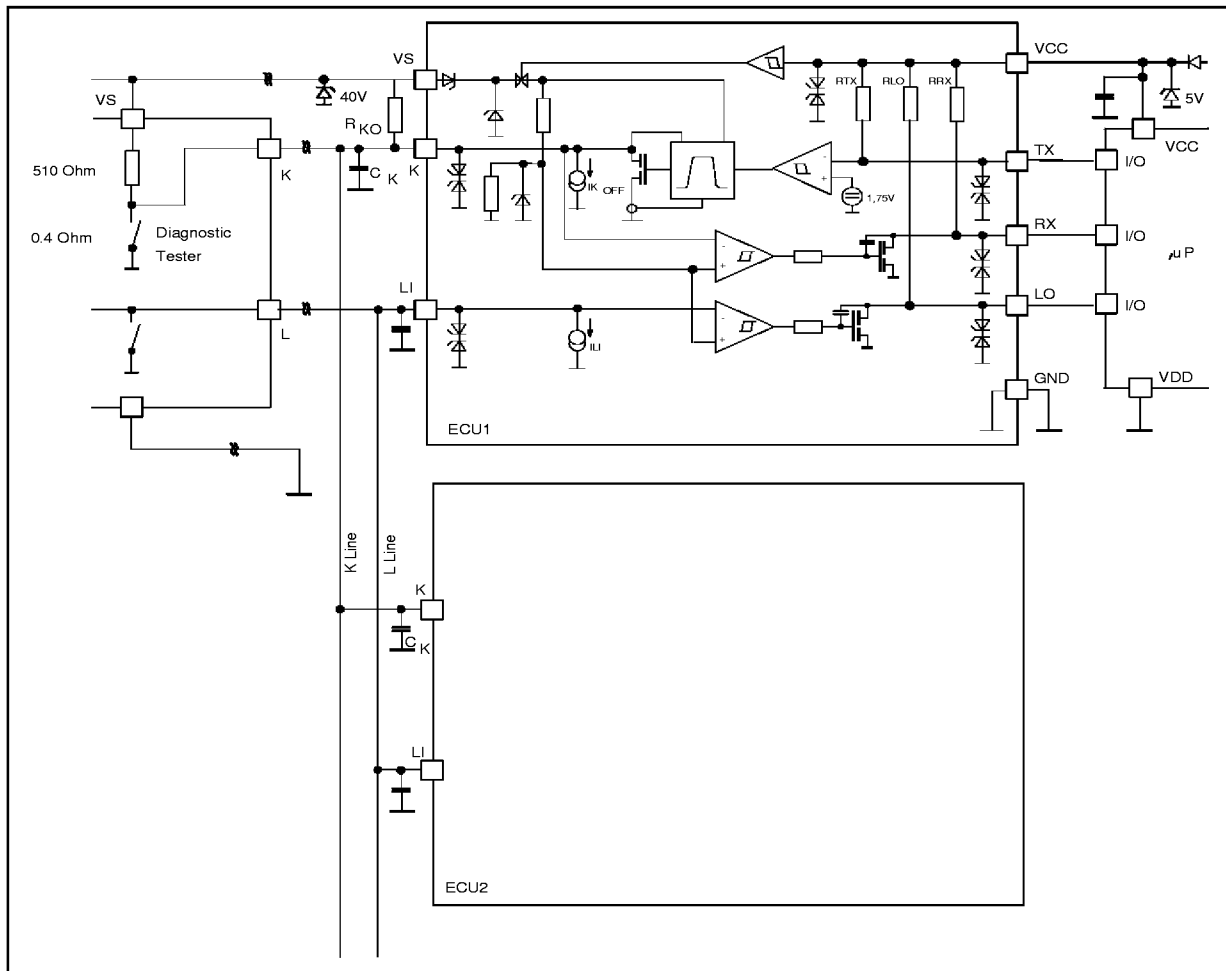

Figure 2: ISO Application Circuit



FUNCTIONAL DESCRIPTION

The L9637 is a monolithic bus driver designed to provide bidirectional serial communication in automotive diagnostic applications according to the specification "Diagnostic Systems ISO9141".

The device provides a bidirectional link, called K, to the V_{Bat} related diagnosis bus. It also includes a separate comparator L which is also able to be linked to the V_{Bat} bus. The input TX and output RX of K are related to V_{CC} with her integrated pull up resistances. Also the L comparator output LO has a pull up resistance connected to V_{CC} .

The maximum external pull resistance at K related to V_S should not be higher than $R_{KO} \leq 5K\Omega$ to achieve clear output ON conditions.

All V_{Bat} bus defined inputs LI and K have supply voltage dependent thresholds together with suf-

ficient hysteresis to suppress line spikes. These pins are protected against overvoltages, shorts to GND and V_S and can also be driven beyond V_S and GND. These features are also given for TX, RX and LI only taking into account the behaviour of the internal pull up resistances. The thermal shut down function switches OFF the K output if the chip temperature increases above the thermal shut down threshold. To reactivate K again the chip temperature must decrease below the K switch ON temp. To achieve no fault for V_S under-voltage conditions the outputs will be switched OFF and stay at high impedance. The device is also protected against reverse battery condition. During lack of V_S or GND all pins shows high impedance characteristic. To realize a lack of the V_S related bus line LI and K the outputs LO and RX shows defined ON status.

Suppressing all 4 classes of "Schaffner" signals all pins can be load with short energy pulses of max. $\pm 0.2\text{mJ}$. All these features together with a high possible baud rate $>50\text{Kbaud}$, controlled output slopes for low EMI, a wide power supply voltage range and a very small quiescent current during OFF (TX LI K=High) condition $I_{\text{Soff typ}} \leq 100\mu\text{A}$, and a real standby function with zero power consumption $I_{\text{SSB typ}} \leq 1\mu\text{A}$ during system depowering $V_{\text{CC}} \leq 0.5\text{V}$ make this device high efficient for automotive bus system.

After wake up of the system from OFF or SB condition the first output signal will have an additional delay time $t_{d\text{typ}} \leq 5\mu\text{s}$ see also Fig. 3.

The typical output voltage behaviour for the K, LO, RX outputs as a function of the output current is shown in Fig.4. Fig.5 shows a waveform of the output signal when the low level changes from $R_{\text{ON}} * I_{\text{OUT}}$ to $I_{\text{OUT}} * 2 * R_{\text{ON}} + U_{\text{BE}}$ state. This variation occurs due to too low output current or after a negative transient forced to the output or to the supply voltage line.

Figure 3: Typical timing for mode transitions.

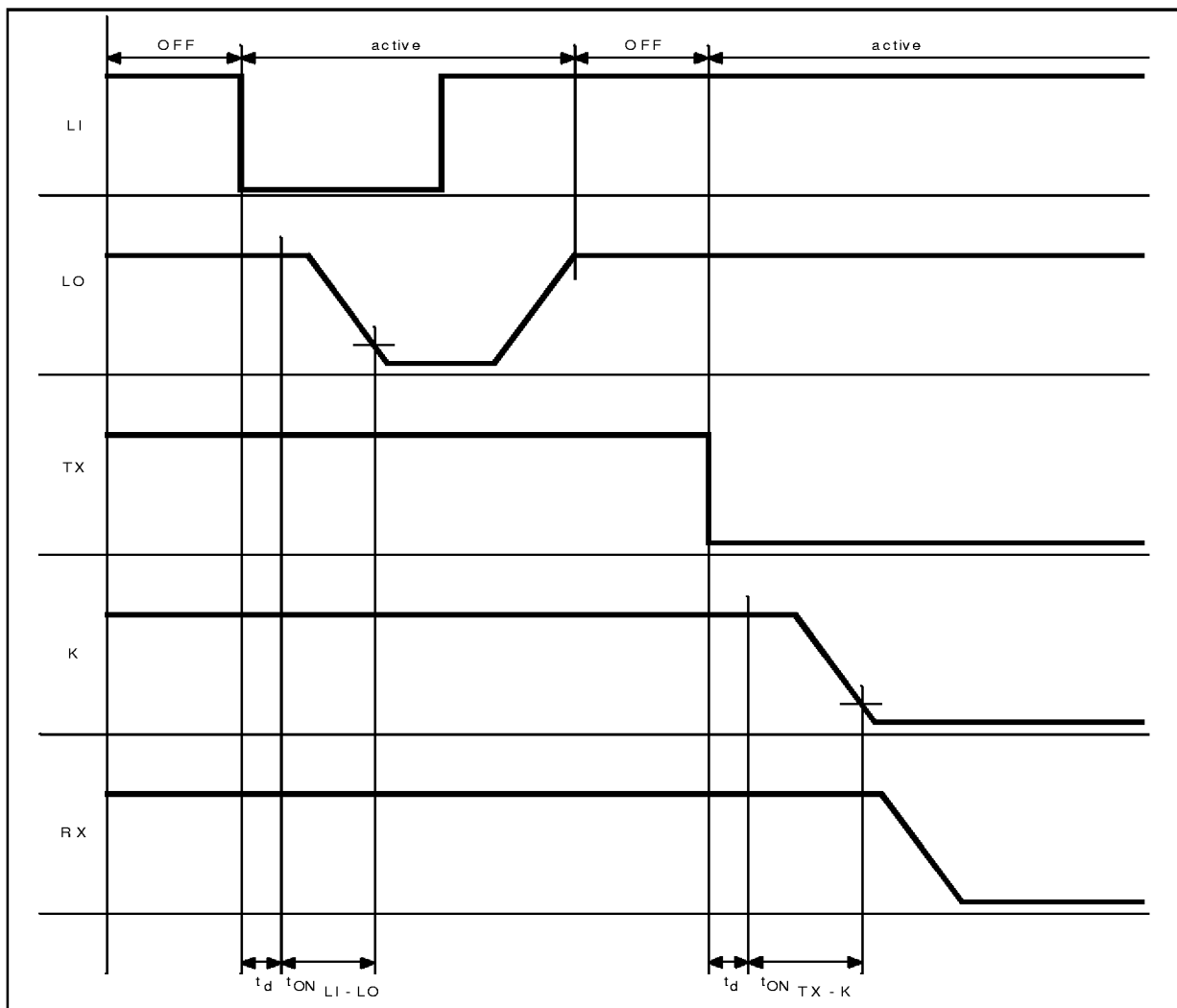

Figure 4: Output Characteristics at K, LO, RX.

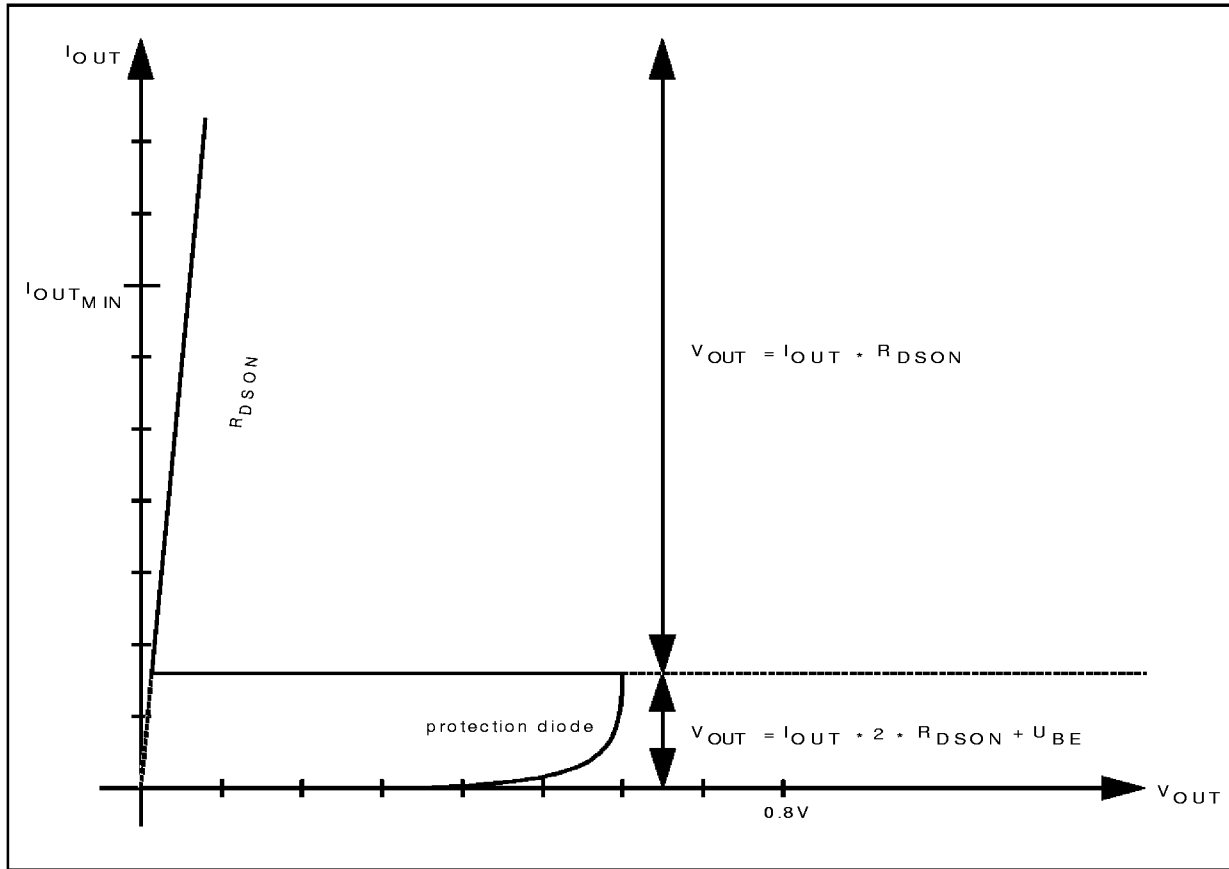

Figure 5: Output Signal Shape Related to Output Current.

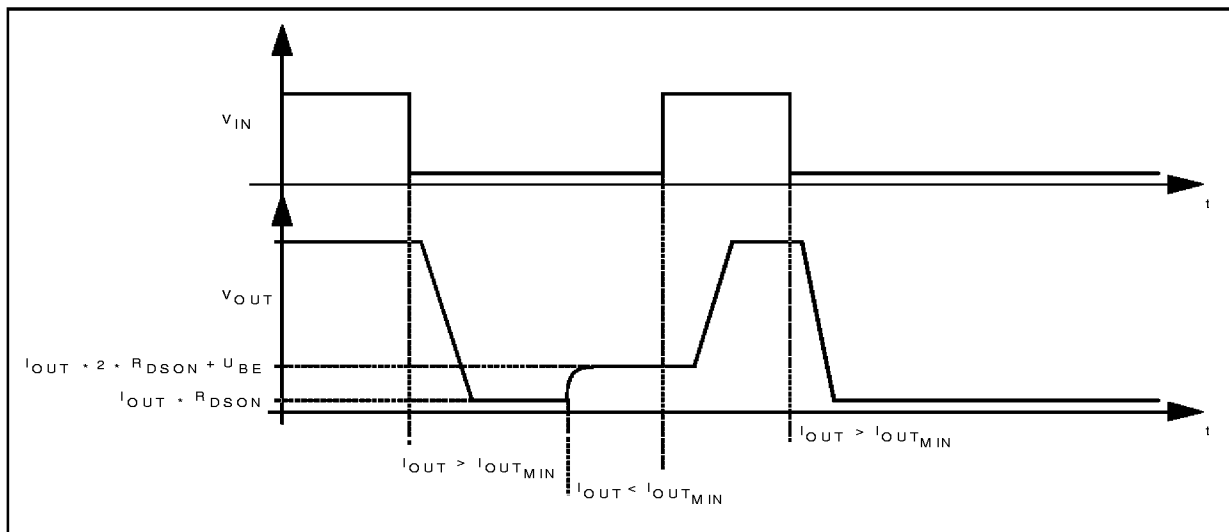

Figure 6: EMS Performance (ISO 9141 BUS system).

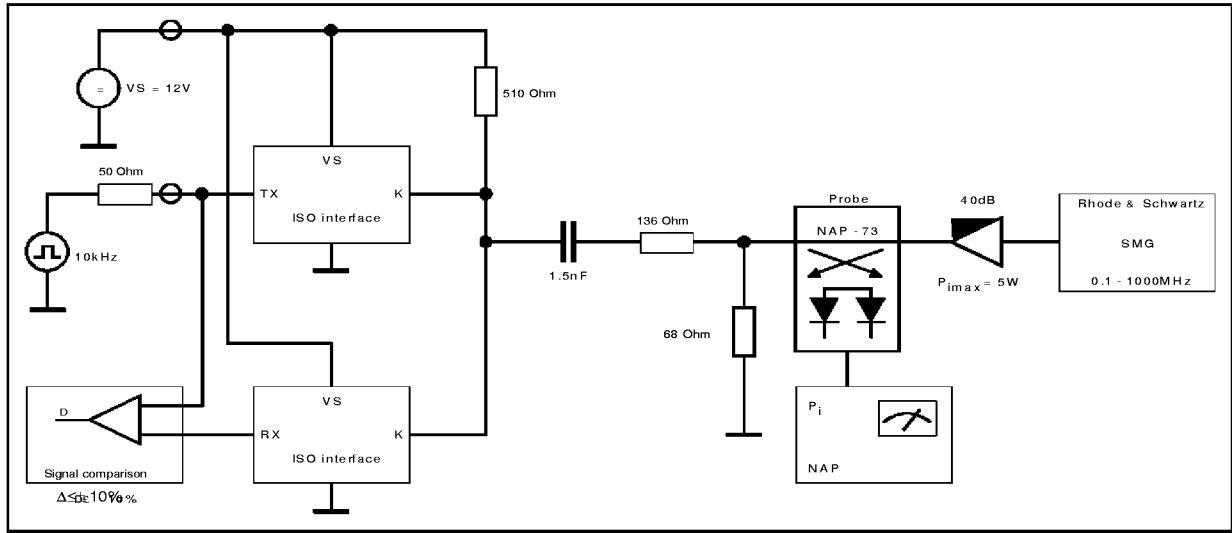
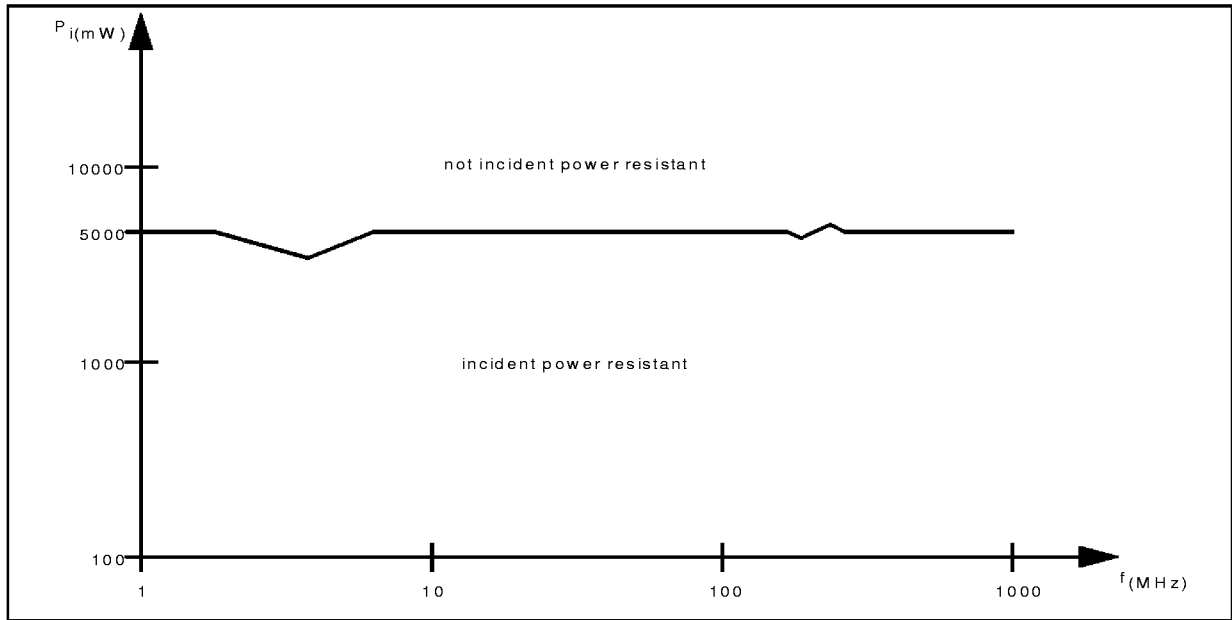
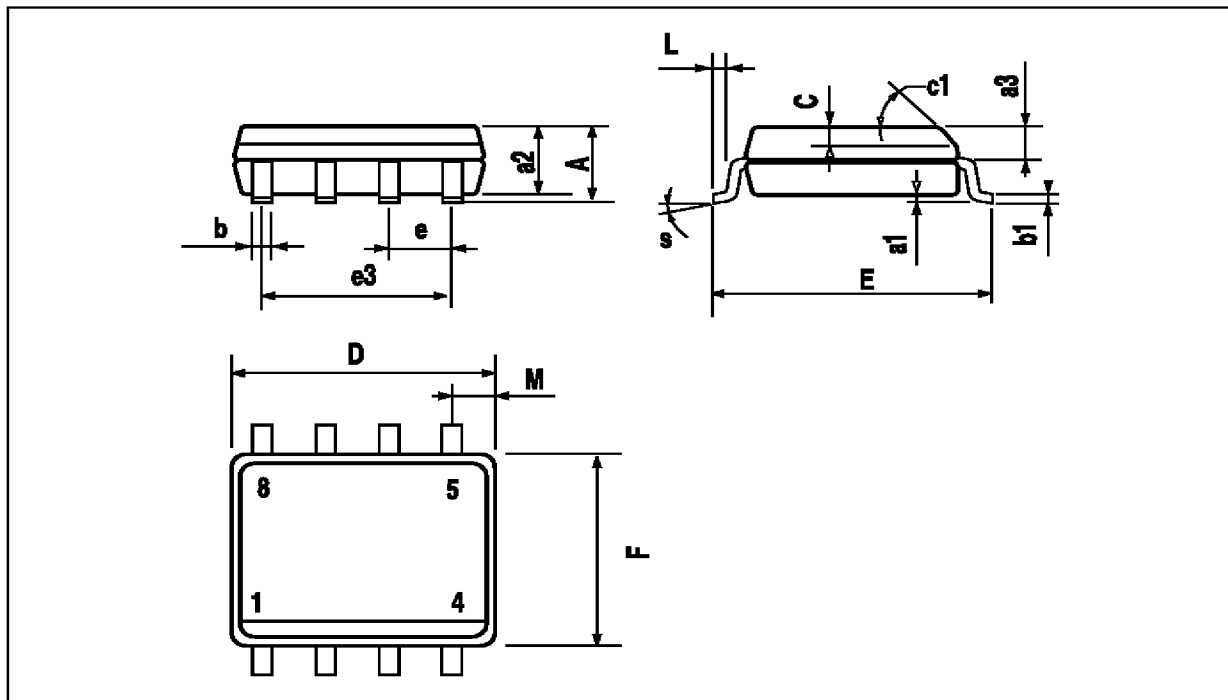

Figure 7.



SO8 PACKAGE MECHANICAL DATA

DIM.	mm			Inch		
	MIN.	TYP.	MAX.	MIN.	TYP.	MAX.
A			1.75			0.069
a1	0.1		0.25	0.004		0.010
a2			1.65			0.065
a3	0.65		0.85	0.026		0.033
b	0.35		0.48	0.014		0.019
b1	0.19		0.25	0.007		0.010
C	0.25		0.5	0.010		0.020
c1	45° (typ.)					
D	4.8		5.0	0.189		0.197
E	5.8		6.2	0.228		0.244
e		1.27			0.050	
e3		3.81			0.150	
F	3.8		4.0	0.15		0.157
L	0.4		1.27	0.016		0.050
M			0.6			0.024
S	8° (max.)					



MINIDIP PACKAGE MECHANICAL DATA

DIM.	mm			Inch		
	MIN.	TYP.	MAX.	MIN.	TYP.	MAX.
A		3.32			0.131	
a1	0.51			0.020		
B	1.15		1.65	0.045		0.065
b	0.356		0.55	0.014		0.022
b1	0.204		0.304	0.008		0.012
D			10.92			0.430
E	7.95		9.75	0.313		0.384
e		2.54			0.100	
e3		7.62			0.300	
e4		7.62			0.300	
F			6.6			0.260
I			5.08			0.200
L	3.18		3.81	0.125		0.150
Z			1.52			0.060

