

# MBC13916



(Scale 2:1)

**Package Information**

Plastic Package  
 Case 1404  
 (SOT-343R)

# MBC13916

## General Purpose SiGe:C RF Cascode Low Noise Amplifier

**Ordering Information**

Device	Device Marking or Operating Temperature Range	Package
MBC13916T1 <sup>1</sup>	916	SOT-343R
MBC13916NT1 <sup>1</sup>	16N	SOT-343R

<sup>1</sup> Refer to [Table 1](#).

## 1 Introduction

The MBC13916 is a cost-effective, high isolation amplifier fabricated with an Advanced RF BiCMOS process using the SiGe:C module. It is intended to be a similar replacement for the MRFIC0916 and is housed in the smaller SOT-343R surface mount package. As with the MRFIC0916, the device is designed for general purpose RF applications, but has improved high frequency gain and noise figure. On-chip bias circuitry sets the bias point, while matching is accomplished off-chip, affording the maximum in application flexibility.

- Usable Frequency Range = 100 to 2500 MHz
- 19 dB typical gain at 900 MHz,  $V_{CC} = 2.7\text{ V}$
- $NF_{min}$  (Device Level) = 0.9 dB @ 900 MHz
- $NF_{min}$  (Device Level) = 1.9 dB @ 1.9 GHz
- 2.5 dBm typical Output Power at 1.0 dB Gain Compression at 900 MHz,  $V_{CC} = 2.7\text{ V}$
- 45 dB Typical Reverse Isolation (Device Level) at 900 MHz,  $V_{CC} = 2.7\text{ V}$
- 4.7 mA Typ Bias Current at  $V_{CC} = 2.7\text{ V}$

**Contents**

**1 Introduction** ..... 1

**2 Ordering Information** ..... 2

**3 Electrical Characteristics** ..... 2

**4 Noise Parameters** ..... 12

**5 Packaging** ..... 13

**6 Product Documentation** ..... 14

Freescale reserves the right to change the detail specifications as may be required to permit improvements in the design of its products.

© Freescale Semiconductor, Inc., 2005. All rights reserved.

## Ordering Information

- 2.7 to 5.0 V Supply
- Industry Standard SOT-343R Package
- Device Weight = 0.00642 g (Typ)
- Available Only in Tape and Reel Packaging
- Available in a lead free version (device number MBC13916NT1) (Refer to [Table 1.](#))

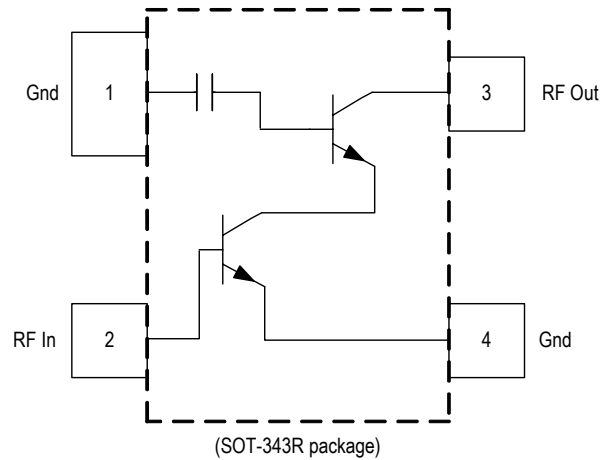

Figure 1. Functional Block Diagram

## 2 Ordering Information

[Table 1](#) provides additional details on MBC13916 orderable parts.

Table 1. Orderable Parts Details

Device	Operating Temp Range (TA.)	Package	Lead Frame	RoHS Compliant	PB-Free	MSL Level	Solder Temp
MBC13916T1	-40° to 85° C	Tape and Reel	Pb Plate	-	No	-	-
MBC13916NT1	-40° to 85° C	Tape and Reel	Pb Free	Yes	Yes	1	260° C

## 3 Electrical Characteristics

Table 2. Recommended Operating Conditions

Characteristic	Symbol	Min	Typ	Max	Unit
RF Frequency	$f_{RF}$	100	-	2500	MHz
Supply Voltage	$V_{CC}$	2.7	-	5.0	Vdc

Table 3. Maximum Ratings

Ratings	Symbol	Value	Unit
Supply Voltage	$V_{CC}$	6.0	Vdc
RF Input Power	$P_{RF}$	10	dBm
Power Dissipation	$P_{DIS}$	100	mW
Supply Current	$I_{CC}$	20	mA
Thermal Resistance, Junction to Case	$R_{\theta JC}$	400	°C/W
Storage Temperature Range	$T_{stg}$	-65 to 150	°C

**Note:** Maximum Ratings and ESD

- Maximum Ratings are those values beyond which damage to the device may occur. Functional operation should be restricted to the limits in the Recommended Operating Conditions and Electrical Characteristics tables.
- ESD (electrostatic discharge) immunity meets Human Body Model (HBM)  $\leq 550$  V and Machine Model (MM)  $\leq 50$  V. Additional ESD data available upon request.

Table 4. Device Level Characteristics

(V<sub>CC</sub> = 2.7 V, T<sub>A</sub> = 25° C, measured in S-parameter test fixture, unless otherwise noted.)

Characteristic	Symbol	Min	Typ	Max	Unit
Insertion Gain f = 900 MHz f = 1900 MHz	$ S_{21} ^2$	- -	16.5 10	- -	dB
Maximum Stable Gain and/or Minimum Available Gain [Note 1] f = 900 MHz f = 1900 MHz	MSG, MAG	- -	24.5 14.3	- -	dB
Minimum Noise Figure [Note 2] f = 900 MHz f = 1900 MHz	$NF_{min}$	- -	0.9 1.9	- -	dB
Output Third Order Intercept Point [Note 3] f = 900 MHz f = 1900 MHz	OIP3	- -	16.5 17	- -	dBm
Reverse Isolation f = 900 MHz f = 1900 MHz	$ S_{12} ^2$	- -	-45 -31	- -	dB

**Note:** 1. Maximum Available Gain and Maximum Stable Gain are defined by the K factor as follows:

$$MAG = \left| \frac{S_{21}}{S_{12}} (K \pm \sqrt{K^2 - 1}) \right|, \text{ if } K > 1, \text{ MSG} = \left| \frac{S_{21}}{S_{12}} \right|, \text{ if } K < 1$$

- Device matched for best noise figure.
- Z<sub>out</sub> matched for optimum IP3.

Electrical Characteristics

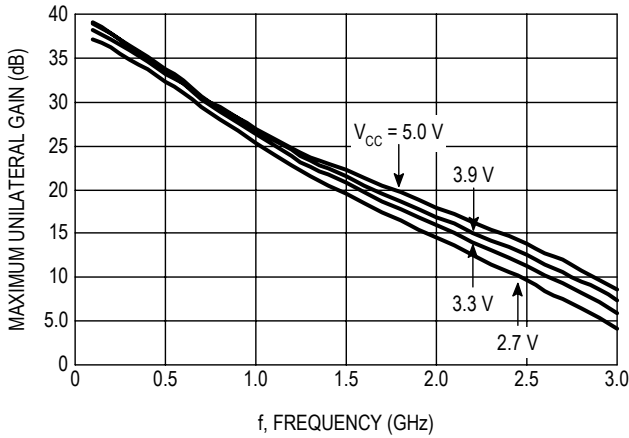

Figure 2. GUMax versus Frequency

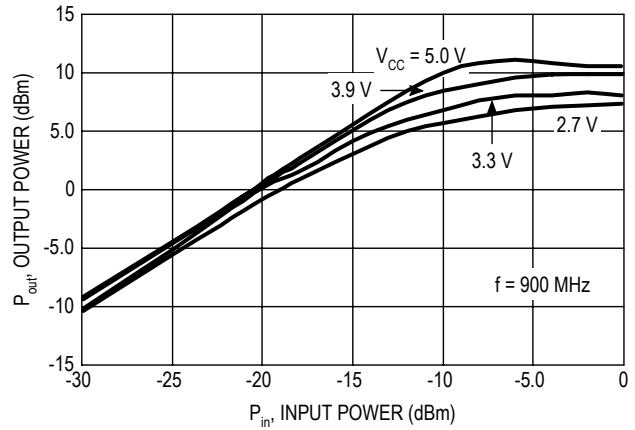

Figure 3. Output Power versus Input Power

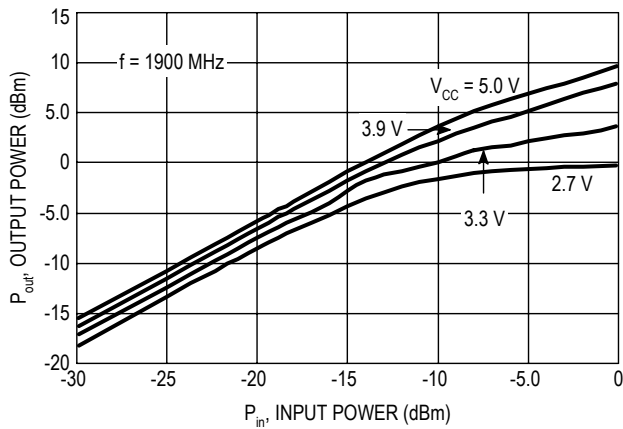

Figure 4. Output Power versus Input Power

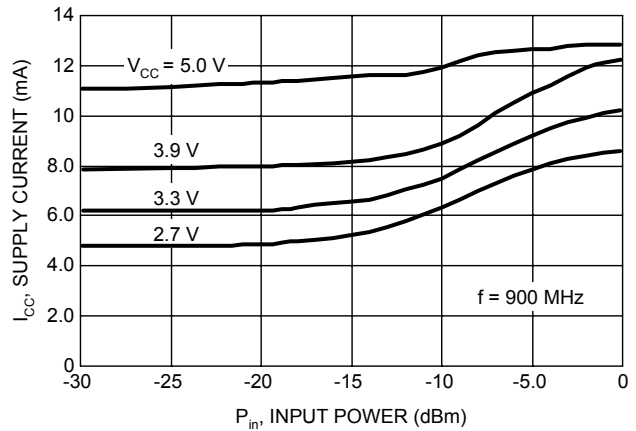

Figure 5. Supply Current versus Input Power

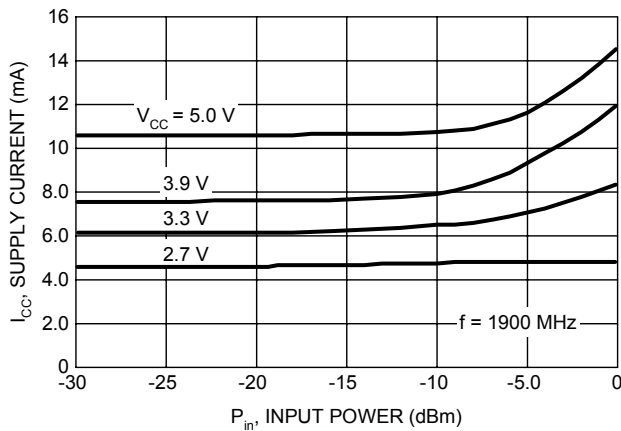

Figure 6. Supply Current versus Input Power

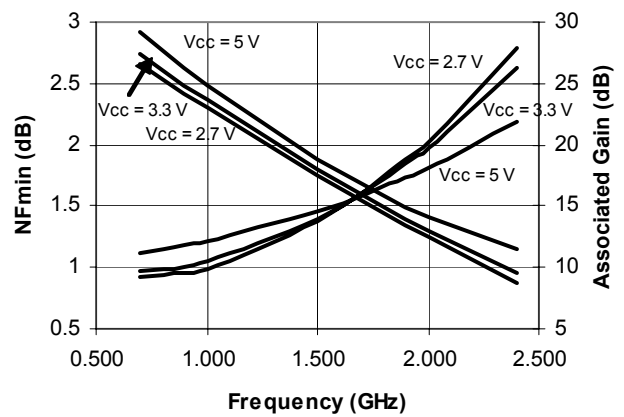

Figure 7. Minimum Noise Figure and Associated Gain Versus Frequency

### 3.1 Applications Circuits

Figures 8 and 9 show the 900 MHz applications circuit configuration and printed circuit board. The 1.9 GHz application configuration circuit and printed circuit board are shown in Figures 10 and 11. Tables 5 and 6 represent the electrical characteristics for the tested 900 MHz and 1.9 GHz application circuits. The bill of materials are listed in Table 7.

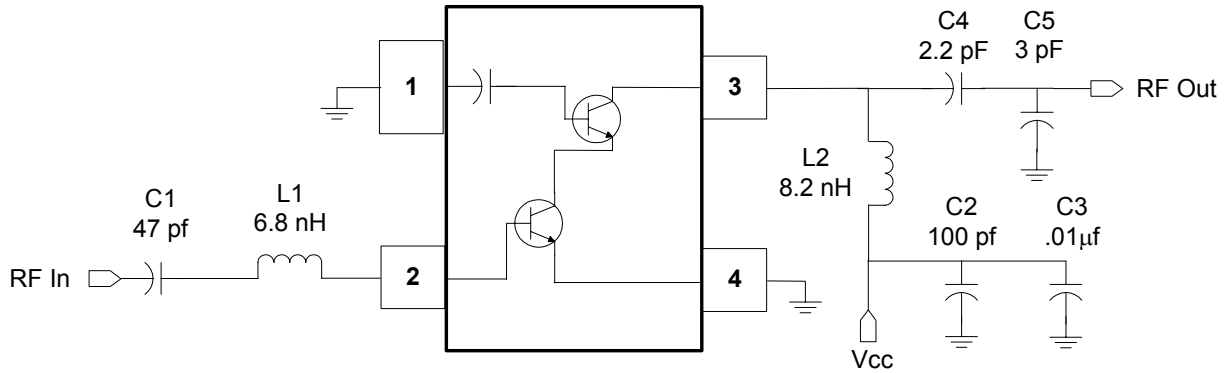

Figure 8. 900 MHz Applications Circuit Configuration

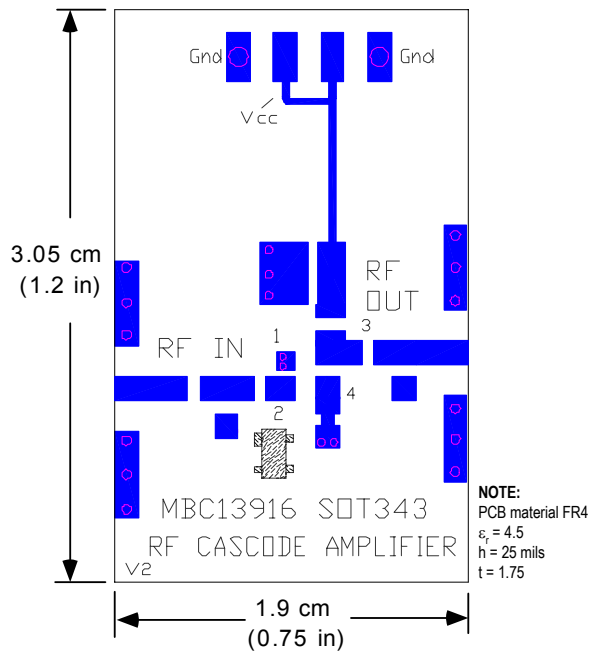

Figure 9. 900 MHz Printed Circuit Board

Table 5. Electrical Characteristics

( $V_{CC} = 2.7\text{ V}$ ,  $T_A = 25^\circ\text{ C}$ ,  $f_{RF} = 900\text{ MHz}$ , Tested in Circuit Shown in Figure 8, unless otherwise noted.)

Characteristic	Symbol	Min	Typ	Max	Unit
Small Signal Gain	$S_{21}$	17	19	21	dB
Noise Figure	NF	-	1.25	-	dB

**Table 5. Electrical Characteristics**

( $V_{CC} = 2.7\text{ V}$ ,  $T_A = 25^\circ\text{ C}$ ,  $f_{RF} = 900\text{ MHz}$ , Tested in Circuit Shown in Figure 8, unless otherwise noted.)

Characteristic	Symbol	Min	Typ	Max	Unit
Power Output at 1.0 dB Gain Compression	$P_{1dB}$	0	2.5	-	dBm
Output 3rd Order Intercept Point	OIP3	-	13	-	dBm
Reverse Isolation	$S_{12}$	-	-42	-	dB
Supply Current	$I_{CC}$	3.8	4.7	5.6	mA

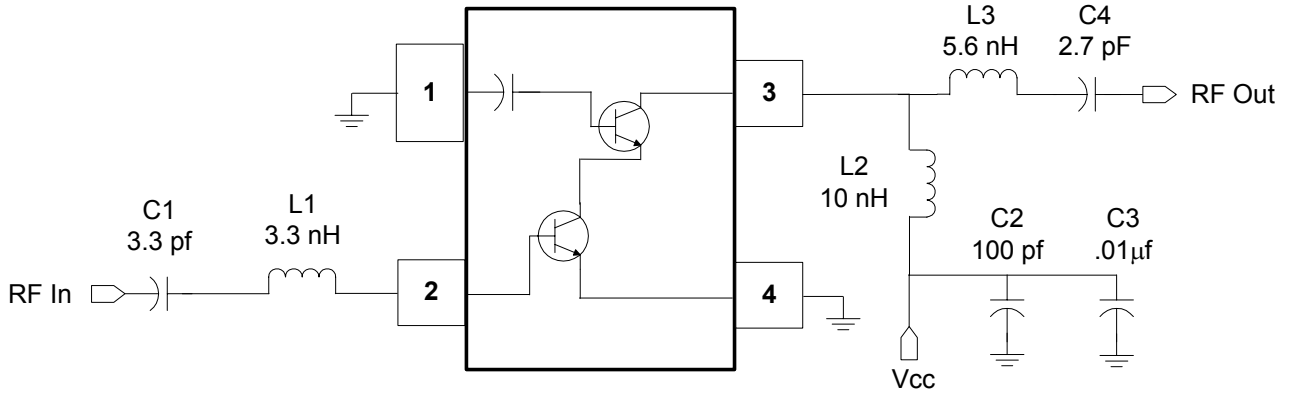

**Figure 10. 1.9 GHz Application Configuration Circuit**

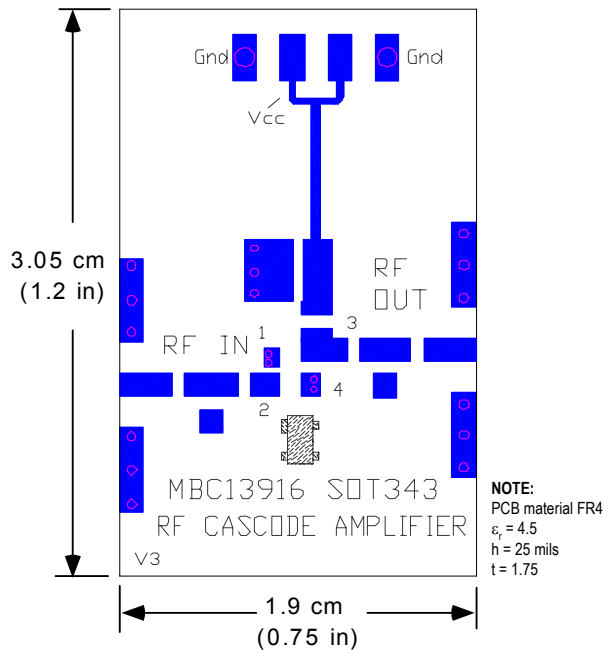

**Figure 11. 1.9 GHz Printed Circuit Board**

**Table 6. Electrical Characteristics**(V<sub>CC</sub> = 2.7 V, T<sub>A</sub> = 25°C, f<sub>RF</sub> = 1.9 GHz, Tested in Circuit Shown in [Figure 10](#), unless otherwise noted.)

Characteristic	Symbol	Min	Typ	Max	Unit
Small Signal Gain	S <sub>21</sub>	9.5	11.5	13.5	dB
Noise Figure	NF	-	2.1	-	dB
Power Output at 1.0 dB Gain Compression	P <sub>1dB</sub>	-	-4.0	-	dBm
Output 3rd Order Intercept Point	OIP3	-	5.5	-	dBm
Reverse Isolation	S <sub>12</sub>	-	-28	-	dB
Supply Current	I <sub>CC</sub>	3.8	4.7	5.6	mA

**Table 7. Bill of Materials**

Component	Value	Case	Manufacturer	Comments
900 MHz <a href="#">Figure 8</a>				
C1	47 pF	0402	Murata	DC Block
C2	100 pF	0603	Murata	RF bypass
C3	.01 uF	0603	Murata	Low freq bypass to improve IP3
C4	2.2 pF	0402	Murata	DC block, Output match
C5	3.0 pF	0402	Murata	Output match, S22 improvement
L1	6.8 nH	1608	Toko	Input match
L2	8.2 nH	1608	Toko	DC Feedthrough, Output match
Q1	MBC13916	SOT343R	Freescale	SiGe cascode amp
1.9 GHz <a href="#">Figure 10</a>				
C1	3.3 pF	603	Murata	DC Block, Input match
C2	100 pF	603	Murata	RF bypass
C3	.01 uF	603	Murata	Low freq bypass to improve IP3
C4	2.7 pF	603	Murata	DC block, Output match
L1	3.3 nH	1608	Murata	Input match
L2	10 nH	1608	Toko	DC Feedthrough, Output match
L3	5.6 nH	1608	Toko	Output match
Q1	MBC13916	SOT343R	Freescale	SiGe cascode amp

**Table 8. Scattering Parameters**  
( $V_{CC} = 2.7\text{ V}$ ,  $50\ \Omega$  System)

f (MHz)	$S_{11}$		$S_{21}$		$S_{12}$		$S_{22}$	
	$ S_{11} $	$\angle\phi$	$ S_{21} $	$\angle\phi$	$ S_{12} $	$\angle\phi$	$ S_{22} $	$\angle\phi$
100	0.829	-11	11.98	165	0.001	17	0.955	-4
200	0.798	-21	11.43	152	0.002	47	0.957	-7
300	0.753	-31	10.69	139	0.002	55	0.956	-11
400	0.701	-39	10.12	128	0.003	56	0.955	-14
500	0.648	-46	9.28	118	0.003	51	0.955	-18
600	0.599	-53	8.66	108	0.004	49	0.954	-22
700	0.554	-58	7.95	98	0.004	41	0.947	-26
800	0.518	-61	7.33	90	0.004	24	0.941	-30
900	0.485	-65	6.83	82	0.004	15	0.933	-34
1000	0.458	-67	6.23	74	0.004	-4	0.926	-38
1100	0.438	-69	5.78	67	0.004	-28	0.915	-43
1200	0.426	-71	5.39	60	0.005	-50	0.902	-46
1300	0.417	-72	4.97	52	0.006	-74	0.893	-51
1400	0.414	-73	4.59	46	0.008	-93	0.879	-54
1500	0.415	-74	4.31	39	0.011	-106	0.868	-58
1600	0.421	-75	3.99	32	0.014	-115	0.851	-62
1700	0.430	-76	3.66	25	0.018	-125	0.835	-66
1800	0.441	-78	3.43	19	0.022	-131	0.818	-70
1900	0.455	-80	3.16	12	0.027	-139	0.803	-73
2000	0.474	-82	2.93	5	0.033	-146	0.777	-77
2100	0.490	-85	2.70	-1	0.039	-152	0.761	-81
2200	0.504	-88	2.48	-8	0.045	-159	0.735	-85
2300	0.524	-92	2.27	-14	0.052	-163	0.707	-89
2400	0.542	-95	2.09	-21	0.059	-169	0.683	-93
2500	0.559	-98	1.90	-28	0.067	-175	0.651	-98
2600	0.572	-103	1.70	-34	0.075	180	0.624	-102
2700	0.587	-106	1.56	-40	0.083	174	0.593	-107
2800	0.603	-110	1.40	-48	0.091	169	0.562	-111
2900	0.610	-114	1.26	-55	0.098	163	0.533	-116
3000	0.613	-118	1.11	-60	0.105	160	0.501	-120



**Table 9. Scattering Parameters**  
( $V_{CC} = 3.0\text{ V}$ ,  $50\ \Omega$  System)

f (MHz)	S <sub>11</sub>		S <sub>21</sub>		S <sub>12</sub>		S <sub>22</sub>	
	S <sub>11</sub>	$\angle\phi$	S <sub>21</sub>	$\angle\phi$	S <sub>12</sub>	$\angle\phi$	S <sub>22</sub>	$\angle\phi$
100	0.812	-11	13.42	165	0.001	11	0.954	-3
200	0.778	-21	12.73	151	0.001	50	0.955	-7
300	0.731	-30	11.82	138	0.002	58	0.956	-11
400	0.677	-38	11.10	127	0.003	50	0.954	-14
500	0.623	-44	10.12	116	0.003	51	0.954	-18
600	0.575	-50	9.37	107	0.003	43	0.952	-22
700	0.533	-54	8.56	98	0.003	30	0.945	-26
800	0.499	-57	7.85	90	0.004	24	0.937	-30
900	0.470	-59	7.29	82	0.004	8	0.930	-34
1000	0.448	-61	6.63	74	0.003	-11	0.923	-38
1100	0.433	-63	6.14	67	0.004	-38	0.911	-42
1200	0.423	-64	5.72	60	0.005	-58	0.900	-46
1300	0.418	-65	5.27	53	0.006	-77	0.891	-50
1400	0.421	-66	4.87	47	0.008	-96	0.878	-54
1500	0.425	-67	4.56	40	0.011	-108	0.868	-58
1600	0.432	-68	4.23	34	0.014	-120	0.852	-61
1700	0.444	-70	3.89	27	0.018	-126	0.838	-65
1800	0.459	-72	3.63	21	0.022	-133	0.822	-69
1900	0.473	-74	3.35	15	0.027	-140	0.809	-73
2000	0.490	-77	3.12	8	0.033	-147	0.784	-77
2100	0.509	-80	2.87	2	0.039	-152	0.769	-80
2200	0.527	-83	2.64	-5	0.045	-159	0.744	-84
2300	0.545	-86	2.42	-11	0.051	-163	0.717	-88
2400	0.560	-90	2.23	-17	0.059	-170	0.694	-92
2500	0.579	-94	2.03	-24	0.067	-175	0.663	-97
2600	0.594	-98	1.82	-30	0.075	-180	0.637	-101
2700	0.606	-101	1.68	-36	0.083	175	0.607	-105
2800	0.620	-105	1.50	-43	0.090	169	0.576	-110
2900	0.630	-110	1.35	-50	0.097	164	0.548	-114
3000	0.636	-113	1.19	-55	0.105	160	0.516	-119

**Table 10. Scattering Parameters**  
( $V_{CC} = 3.9\text{ V}$ ,  $50\ \Omega$  System)

f (MHz)	S <sub>11</sub>		S <sub>21</sub>		S <sub>12</sub>		S <sub>22</sub>	
	S <sub>11</sub>	∠φ	S <sub>21</sub>	∠φ	S <sub>12</sub>	∠φ	S <sub>22</sub>	∠φ
100	0.796	-11	14.82	164	0.001	25	0.954	-3
200	0.760	-20	13.98	150	0.001	50	0.955	-7
300	0.711	-29	12.90	137	0.002	46	0.955	-11
400	0.655	-36	12.03	126	0.002	55	0.955	-14
500	0.602	-42	10.90	115	0.003	50	0.954	-18
600	0.556	-46	10.04	106	0.003	45	0.954	-22
700	0.517	-50	9.12	97	0.003	34	0.947	-26
800	0.487	-52	8.34	89	0.003	22	0.940	-30
900	0.463	-54	7.72	82	0.003	11	0.933	-34
1000	0.444	-56	7.02	74	0.003	-6	0.927	-38
1100	0.432	-57	6.49	67	0.003	-40	0.917	-42
1200	0.428	-58	6.03	61	0.005	-69	0.905	-46
1300	0.427	-59	5.55	53	0.006	-88	0.896	-50
1400	0.430	-60	5.13	48	0.008	-99	0.883	-53
1500	0.437	-61	4.81	41	0.011	-111	0.874	-57
1600	0.449	-62	4.45	35	0.014	-118	0.858	-61
1700	0.462	-64	4.09	29	0.018	-128	0.843	-64
1800	0.475	-66	3.83	23	0.022	-134	0.829	-68
1900	0.493	-69	3.53	17	0.027	-140	0.815	-72
2000	0.512	-72	3.28	10	0.032	-148	0.790	-76
2100	0.529	-75	3.03	4	0.038	-152	0.776	-79
2200	0.544	-78	2.79	-2	0.045	-159	0.752	-83
2300	0.565	-82	2.56	-8	0.051	-164	0.726	-87
2400	0.583	-85	2.37	-14	0.058	-169	0.704	-91
2500	0.599	-89	2.16	-21	0.067	-175	0.674	-96
2600	0.613	-93	1.94	-27	0.075	-179	0.648	-100
2700	0.629	-97	1.79	-32	0.083	175	0.621	-105
2800	0.643	-101	1.60	-39	0.091	170	0.589	-109
2900	0.650	-105	1.44	-46	0.098	164	0.562	-114
3000	0.653	-109	1.28	-51	0.105	160	0.531	-118

**Table 11. Scattering Parameters**  
( $V_{CC} = 5.0\text{ V}$ ,  $50\ \Omega$  System)

f (MHz)	S <sub>11</sub>		S <sub>21</sub>		S <sub>12</sub>		S <sub>22</sub>	
	S <sub>11</sub>	∠φ	S <sub>21</sub>	∠φ	S <sub>12</sub>	∠φ	S <sub>22</sub>	∠φ
100	0.719	-9	21.47	161	0.001	5	0.939	-3
200	0.678	-17	19.60	145	0.001	18	0.939	-7
300	0.628	-23	17.43	132	0.001	38	0.940	-10
400	0.579	-27	15.66	120	0.002	47	0.937	-14
500	0.540	-30	13.78	110	0.002	38	0.936	-18
600	0.512	-32	12.40	101	0.003	37	0.934	-22
700	0.492	-34	11.05	93	0.002	32	0.927	-26
800	0.480	-34	9.97	86	0.002	9	0.920	-30
900	0.472	-35	9.12	79	0.002	-14	0.914	-34
1000	0.470	-37	8.21	73	0.002	-54	0.908	-38
1100	0.473	-37	7.54	67	0.003	-75	0.899	-42
1200	0.478	-39	6.97	61	0.004	-90	0.890	-46
1300	0.484	-40	6.37	54	0.006	-101	0.884	-50
1400	0.496	-42	5.86	50	0.008	-114	0.875	-54
1500	0.509	-44	5.49	44	0.010	-120	0.871	-57
1600	0.521	-46	5.08	39	0.013	-128	0.858	-60
1700	0.535	-49	4.67	34	0.017	-133	0.848	-63
1800	0.552	-51	4.38	29	0.021	-139	0.838	-67
1900	0.570	-54	4.06	23	0.025	-144	0.829	-70
2000	0.587	-56	3.80	18	0.030	-150	0.807	-73
2100	0.604	-60	3.54	13	0.036	-154	0.795	-76
2200	0.621	-63	3.28	7	0.042	-160	0.772	-79
2300	0.643	-67	3.04	2	0.048	-164	0.746	-83
2400	0.658	-70	2.84	-4	0.056	-169	0.722	-87
2500	0.673	-74	2.61	-10	0.063	-175	0.687	-91
2600	0.690	-78	2.36	-16	0.071	-179	0.657	-96
2700	0.705	-82	2.19	-21	0.079	176	0.623	-101
2800	0.715	-86	1.97	-27	0.088	170	0.588	-107
2900	0.720	-91	1.78	-33	0.094	164	0.556	-113
3000	0.723	-94	1.57	-38	0.101	161	0.523	-119

## 4 Noise Parameters

Noise parameters for the MBC13916 are represented in [Table 12](#).

**Table 12. Noise Parameters**

Freq	Fmin	Gamma Opt		Rn	Ga
MHz	dB	Mag	Angle		dB
(V <sub>CC</sub> = 2.7 V, I <sub>CC</sub> = 4.7 mA)					
0.500	0.92	0.14	47.6	0.18	29.08
0.700	0.92	0.14	64.2	0.14	26.61
0.900	0.96	0.14	79.6	0.12	24.22
1.000	0.99	0.14	86	0.11	23.05
1.500	1.37	0.15	119.4	0.11	17.5
1.900	1.88	0.17	140.3	0.15	13.4
2.000	2.03	1.8	144.9	0.16	12.43
2.400	2.79	0.2	160.4	0.22	8.71
V <sub>CC</sub> = 3.3 V, I <sub>CC</sub> = 6 mA					
0.500	0.96	0.13	35.5	0.19	29.98
0.700	0.97	0.13	55.3	0.15	27.34
0.900	1	0.12	75.1	0.13	24.81
1.000	1.05	0.12	85.1	0.12	23.59
1.500	1.39	0.13	135.7	0.12	17.91
1.900	1.84	0.14	176.5	0.16	13.88
2.000	1.97	0.15	-173.9	0.17	12.95
2.400	2.62	0.17	-135.5	0.24	9.48
V <sub>CC</sub> = 5 V, I <sub>CC</sub> = 10.5 mA					
0.500	1.07	0.11	0.2	0.21	32.36
0.700	1.11	0.1	28.8	0.18	29.19
0.900	1.18	0.09	61.3	0.15	26.22
1.000	1.21	0.08	78.8	0.14	24.87
1.500	1.46	0.07	179.8	0.13	18.81
1.900	1.74	0.07	-83.2	0.19	14.98
2.000	1.82	0.07	-56.7	0.22	14.17
2.400	2.19	0.09	58.2	0.2	11.47

## 5 Packaging

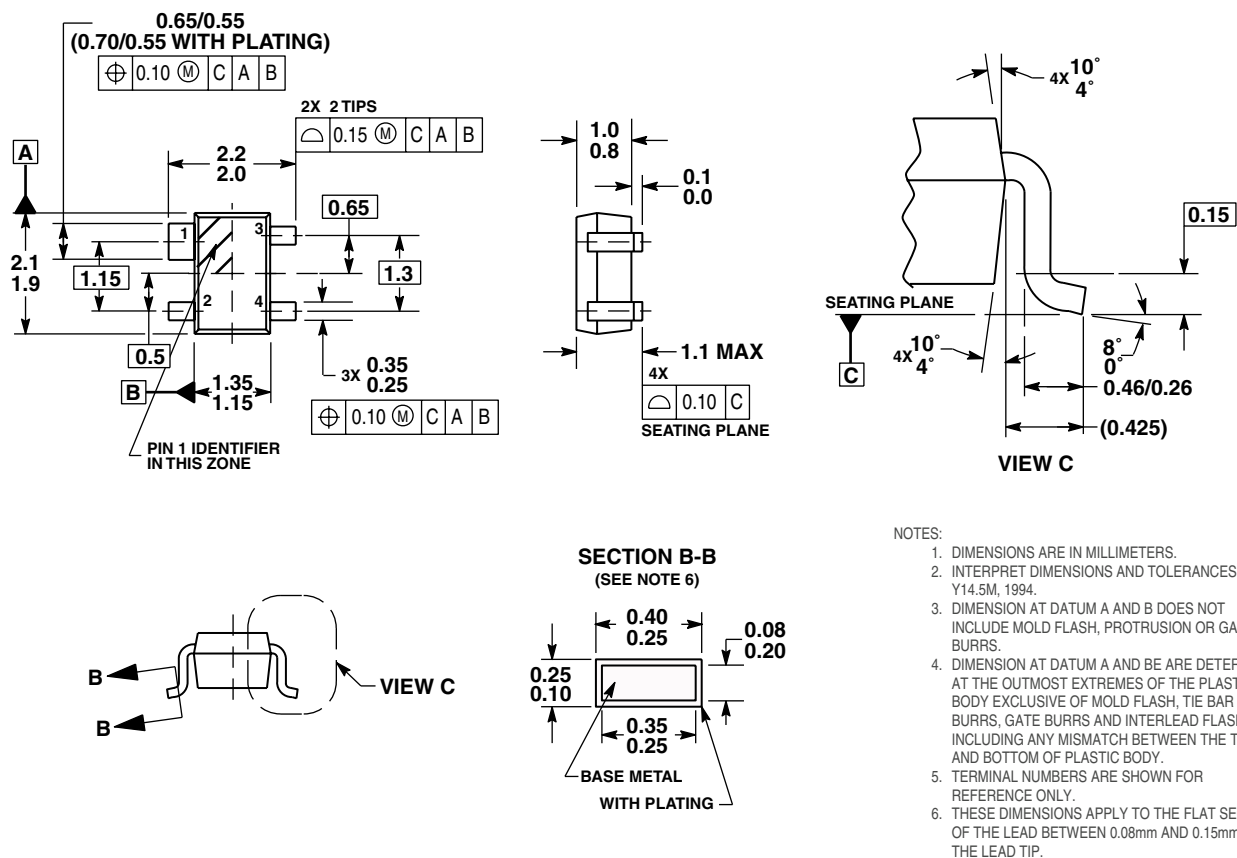

**Figure 12. Outline Dimensions for SOT-343R**  
(Case 1404-01, Issue 0)

## 6 Product Documentation

This data sheet is labeled as a particular type: Product Preview, Advance Information, or Technical Data. Definitions of these types are available at: <http://www.freescale.com> on the documentation page.

[Table 13](#) summarizes revisions to this document since the previous release (Rev. 2).

**Table 13. Revision History**

Location	Revision
<a href="#">Table 1</a> Orderable Parts Details	Updated



**How to Reach Us:**

**Home Page:**  
[www.freescale.com](http://www.freescale.com)

**E-mail:**  
[support@freescale.com](mailto:support@freescale.com)

**USA/Europe or Locations Not Listed:**  
Freescale Semiconductor  
Technical Information Center, CH370  
1300 N. Alma School Road  
Chandler, Arizona 85224  
+1-800-521-6274 or +1-480-768-2130  
[support@freescale.com](mailto:support@freescale.com)

**Europe, Middle East, and Africa:**  
Freescale Halbleiter Deutschland GmbH  
Technical Information Center  
Schatzbogen 7  
81829 Muenchen, Germany  
+44 1296 380 456 (English)  
+46 8 52200080 (English)  
+49 89 92103 559 (German)  
+33 1 69 35 48 48 (French)  
[support@freescale.com](mailto:support@freescale.com)

**Japan:**  
Freescale Semiconductor Japan Ltd.  
Headquarters  
ARCO Tower 15F  
1-8-1, Shimo-Meguro, Meguro-ku,  
Tokyo 153-0064, Japan  
0120 191014 or +81 3 5437 9125  
[support.japan@freescale.com](mailto:support.japan@freescale.com)

**Asia/Pacific:**  
Freescale Semiconductor Hong Kong Ltd.  
Technical Information Center  
2 Dai King Street  
Tai Po Industrial Estate  
Tai Po, N.T., Hong Kong  
+800 2666 8080  
[support.asia@freescale.com](mailto:support.asia@freescale.com)

**For Literature Requests Only:**  
Freescale Semiconductor Literature Distribution Center  
P.O. Box 5405  
Denver, Colorado 80217  
1-800-521-6274 or 303-675-2140  
Fax: 303-675-2150  
[LDCForFreescaleSemiconductor@hibbertgroup.com](mailto:LDCForFreescaleSemiconductor@hibbertgroup.com)

Information in this document is provided solely to enable system and software implementers to use Freescale Semiconductor products. There are no express or implied copyright licenses granted hereunder to design or fabricate any integrated circuits or integrated circuits based on the information in this document.

Freescale Semiconductor reserves the right to make changes without further notice to any products herein. Freescale Semiconductor makes no warranty, representation or guarantee regarding the suitability of its products for any particular purpose, nor does Freescale Semiconductor assume any liability arising out of the application or use of any product or circuit, and specifically disclaims any and all liability, including without limitation consequential or incidental damages. "Typical" parameters that may be provided in Freescale Semiconductor data sheets and/or specifications can and do vary in different applications and actual performance may vary over time. All operating parameters, including "Typicals", must be validated for each customer application by customer's technical experts. Freescale Semiconductor does not convey any license under its patent rights nor the rights of others. Freescale Semiconductor products are not designed, intended, or authorized for use as components in systems intended for surgical implant into the body, or other applications intended to support or sustain life, or for any other application in which the failure of the Freescale Semiconductor product could create a situation where personal injury or death may occur. Should Buyer purchase or use Freescale Semiconductor products for any such unintended or unauthorized application, Buyer shall indemnify and hold Freescale Semiconductor and its officers, employees, subsidiaries, affiliates, and distributors harmless against all claims, costs, damages, and expenses, and reasonable attorney fees arising out of, directly or indirectly, any claim of personal injury or death associated with such unintended or unauthorized use, even if such claim alleges that Freescale Semiconductor was negligent regarding the design or manufacture of the part.

Freescale™ and the Freescale logo are trademarks of Freescale Semiconductor, Inc. All other product or service names are the property of their respective owners.

© Freescale Semiconductor, Inc. 2005. All rights reserved.

RoHS-compliant and/or Pb-free versions of Freescale products have the functionality and electrical characteristics of their non-RoHS-compliant and/or non-Pb-free counterparts. For further information, see <http://www.freescale.com> or contact your Freescale sales representative.

For information on Freescale's Environmental Products program, go to <http://www.freescale.com/epp>.