

**DUAL OPERATIONAL AMPLIFIERS**

- LOW POWER CONSUMPTION
- LARGE INPUT VOLTAGE RANGE
- NO LATCH-UP
- HIGH GAIN
- SHORT-CIRCUIT PROTECTION
- NO FREQUENCY COMPENSATION REQUIRED

**DESCRIPTION**

The MC1458 is a high performance monolithic dual operational amplifier intended for a wide range of analog applications :

- Summing amplifier
- Voltage follower
- Integrator
- Active filter
- Function generator

The high gain and wide range of operating voltages provide superior performance in integrator, summing amplifier, and general feed back applications.

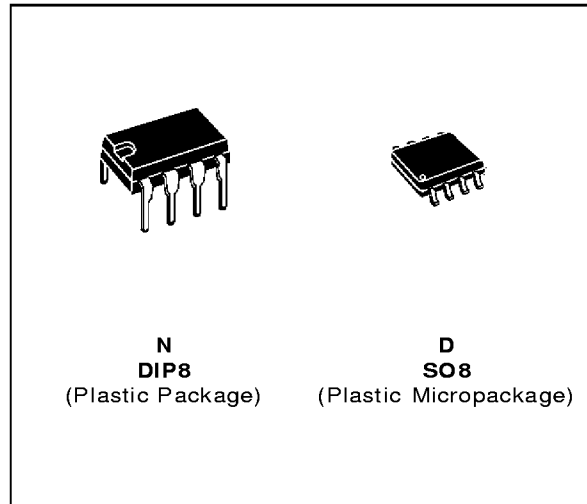

**ORDER CODES**

Part Number	Temperature Range	Package	
		N	D
MC1458	0, +70°C	•	•
MC1458I	-40, +105°C	•	•
MC1558	-55, +125°C	•	•

**Example** : MC1458N

**PIN CONNECTIONS (top view)**

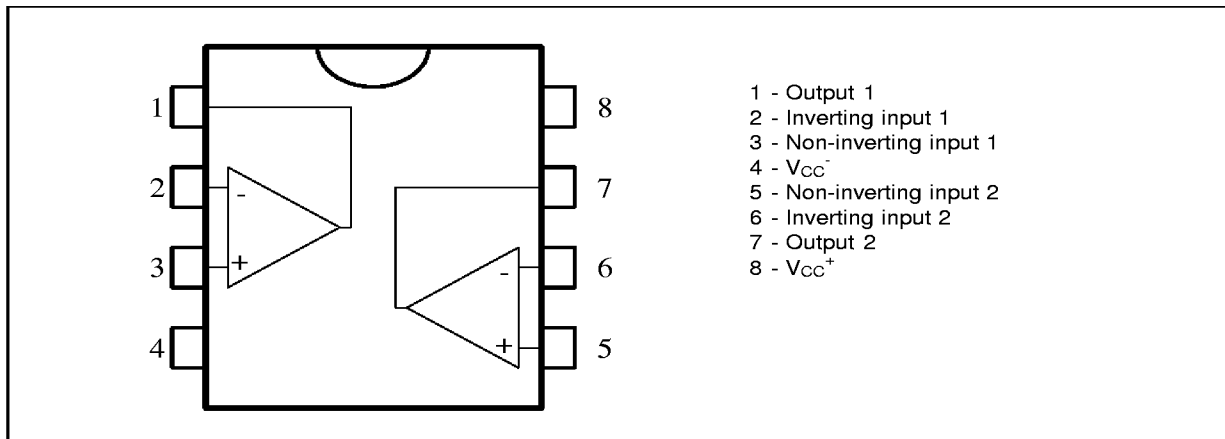

**SCHEMATIC DIAGRAM**

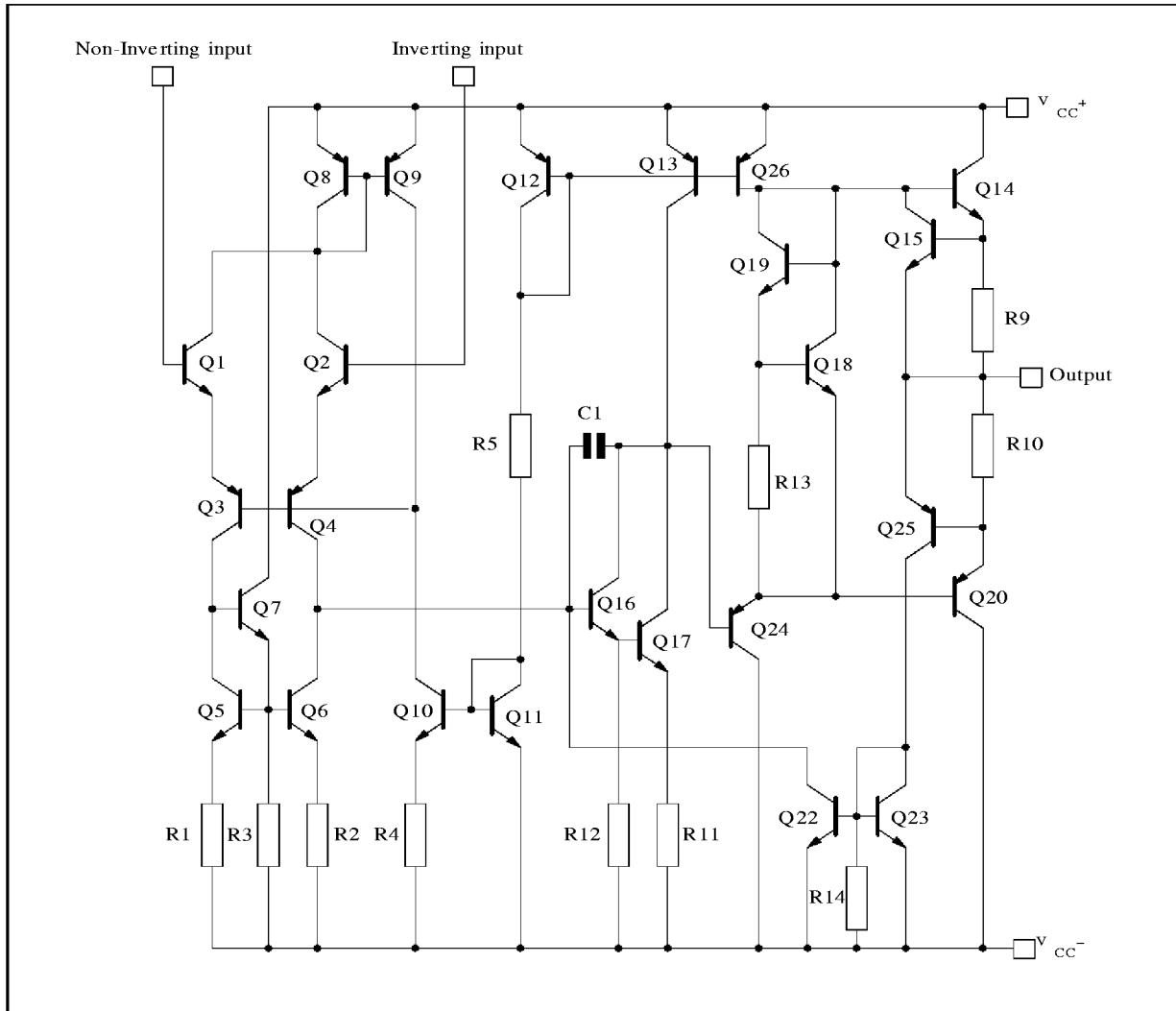

**ABSOLUTE MAXIMUM RATINGS**

Symbol	Parameter	MC1458	MC1458I	MC1558	Unit
V <sub>CC</sub>	Supply Voltage	±22	±22	±22	V
V <sub>i</sub>	Input Voltage	±15	±15	±15	V
V <sub>id</sub>	Differential Input Voltage	±30	±30	±30	V
P <sub>tot</sub>	Power Dissipation	D Suffix N Suffix			mW
	Output Short-circuit Duration	Infinite			
T <sub>oper</sub>	Operating Free-air Temperature Range	0 to +70	-40 to +105	-55 to +125	°C
T <sub>stg</sub>	Storage Temperature Range	-65 to +150	-65 to +150	-65 to +150	°C

**ELECTRICAL CHARACTERISTICS** $V_{CC} = \pm 15V$ ,  $T_{amb} = 25^{\circ}C$ , (unless otherwise specified)

Symbol	Parameter	MC1458 - 1458I - 1558			Unit
		Min.	Typ.	Max.	
$V_{io}$	Input Offset Voltage ( $R_S \leq 10k\Omega$ ) $T_{amb} = 25^{\circ}C$ $T_{min.} \leq T_{amb} \leq T_{max.}$		1	5 6	mV
$I_{io}$	Input Offset Current $T_{amb} = 25^{\circ}C$ $T_{min.} \leq T_{amb} \leq T_{max.}$		2	200 300	nA
$I_{ib}$	Input Bias Current $T_{amb} = 25^{\circ}C$ $T_{min.} \leq T_{amb} \leq T_{max.}$		30	500 800	nA
$A_{vd}$	Large Signal Voltage Gain ( $V_O = \pm 10V$ , $R_L = 2k\Omega$ ) $T_{amb} = 25^{\circ}C$ $T_{min.} \leq T_{amb} \leq T_{max.}$	50 25	200		V/mV
SVR	Supply Voltage Rejection Ratio ( $R_S \leq 10k\Omega$ ) $T_{amb} = 25^{\circ}C$ $T_{min.} \leq T_{amb} \leq T_{max.}$	77 77	90		dB
$I_{CC}$	Supply Current, all Amp, no Load $T_{amb} = 25^{\circ}C$ $T_{min.} \leq T_{amb} \leq T_{max.}$		2.3	5 6	mA
$V_{icm}$	Input Common Mode Voltage Range $T_{amb} = 25^{\circ}C$ $T_{min.} \leq T_{amb} \leq T_{max.}$	$\pm 12$ $\pm 12$			V
CMR	Common-mode Rejection Ratio ( $R_S \leq 10 k\Omega$ ) $T_{amb} = 25^{\circ}C$ $T_{min} \leq T_{amb} \leq T_{max}$	70 70	90		dB
$I_{OS}$	Output Short-circuit Current $T_{amb} = 25^{\circ}C$	10	20	35	mA
$\pm V_{OPP}$	Output Voltage Swing $T_{amb} = 25^{\circ}C$ $T_{min.} \leq T_{amb} \leq T_{max.}$	$R_L = 10k\Omega$ 12 $R_L = 2k\Omega$ 10 $R_L = 10k\Omega$ 12 $R_L = 2k\Omega$ 10	14 13		V
SR	Slew Rate ( $V_I = \pm 10V$ , $R_L = 2k\Omega$ , $C_L = 100pF$ , $T_{amb} = 25^{\circ}C$ , unity gain)	0.2	0.8		V/ $\mu s$
$t_r$	Rise Time ( $V_I = 20mV$ , $R_L = 2k\Omega$ , $C_L = 100pF$ , $T_{amb} = 25^{\circ}C$ , unity gain)		0.3		$\mu s$
$K_{OV}$	Overshoot ( $V_I = 20mV$ , $R_L = 2k\Omega$ , $C_L = 100pF$ , $T_{amb} = 25^{\circ}C$ , unity gain)		5		%
$R_I$	Input Resistance	0.3	2		$M\Omega$
$Z_{ic}$	Common-mode Input Impedance		200		$M\Omega$
$C_I$	Input Capacitance		1.4		pF
$R_O$	Output Resistance		75		$\Omega$
FPB	Full Power Bandwidth ( $R_L = 2k\Omega$ , $V_O \geq \pm 10V$ , $A_{VD} = 1$ , $THD \leq 5\%$ )		14		KHz
B	Unity Gain Bandwidth ( $V_I = 10mV$ , $R_L = 2k\Omega$ , $C_L = 100pF$ , $T_{amb} = 25^{\circ}C$ )		1		MHz

**MC1458 - MC1558**

**ELECTRICAL CHARACTERISTICS (continued)**

Symbol	Parameter	MC1458 - 1458I MC1558			Unit
		Min.	Typ.	Max.	
GBP	Gain Bandwidth Product ( $V_i = 10\text{mV}$ , $R_L = 2\text{k}\Omega$ , $C_L = 100\text{pF}$ , $f = 100\text{kHz}$ , $T_{\text{amb}} = 25^\circ\text{C}$ )	0.4	1		MHz
THD	Total Harmonic Distortion ( $f = 1\text{kHz}$ , $A_V = 20\text{dB}$ , $R_L = 2\text{k}\Omega$ , $V_O = 2V_{\text{PP}}$ , $C_L = 100\text{pF}$ , $T_{\text{amb}} = 25^\circ\text{C}$ )		0.02		%
$e_n$	Equivalent Input Noise Voltage ( $f = \text{kHz}$ , $R_s = 100\Omega$ )		45		$\frac{\text{nV}}{\sqrt{\text{Hz}}}$
$\phi_m$	Phase Margin		65		Degrees
Am	Gain Margin		11		dB
$V_{O1}/V_{O2}$	Channel Separation		120		dB

**OPEN LOOP VOLTAGE GAIN**

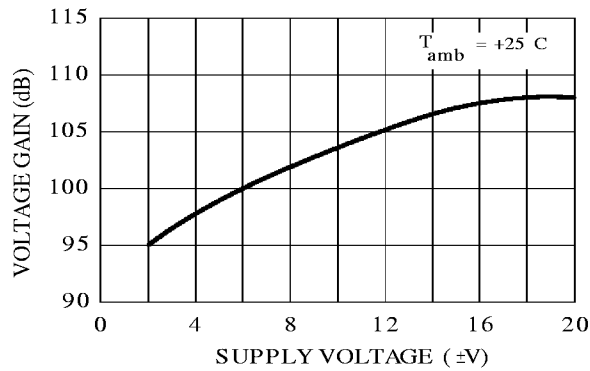

**OPEN LOOP FREQUENCY RESPONSE**

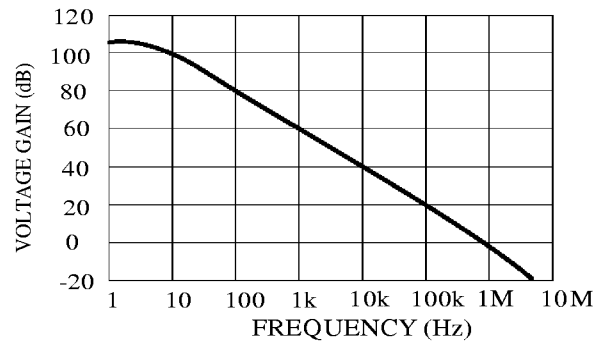

**POWER BANDWIDTH (LARGE SIGNAL SWING)**

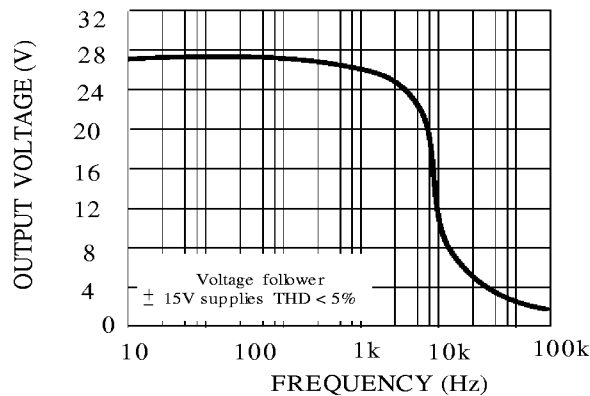

**POWER CONSUMPTION**

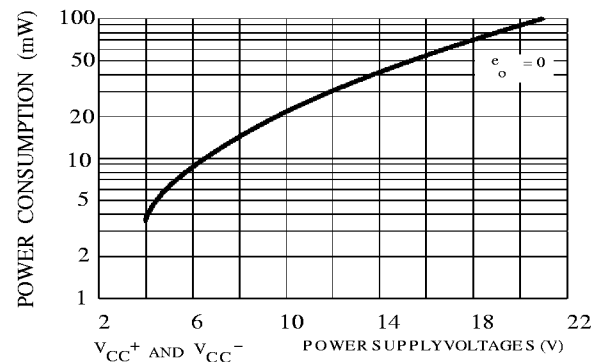

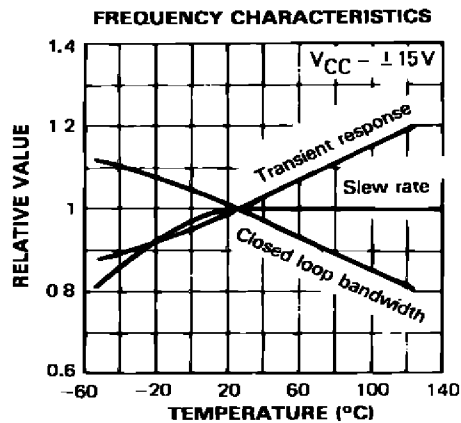
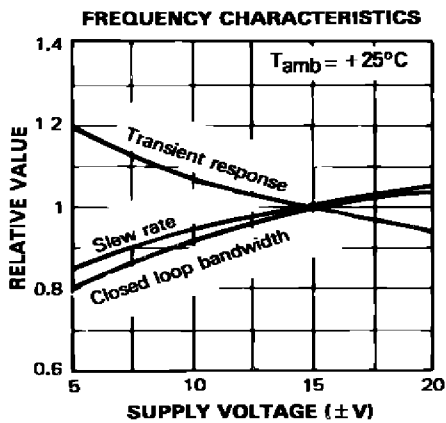
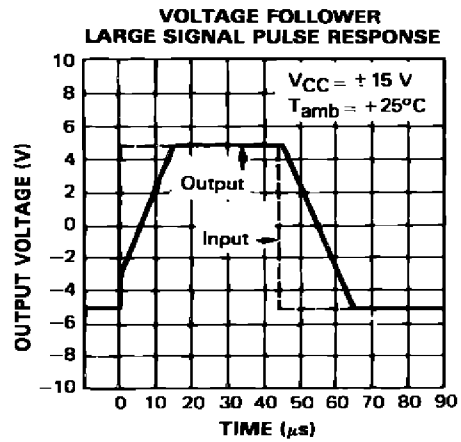
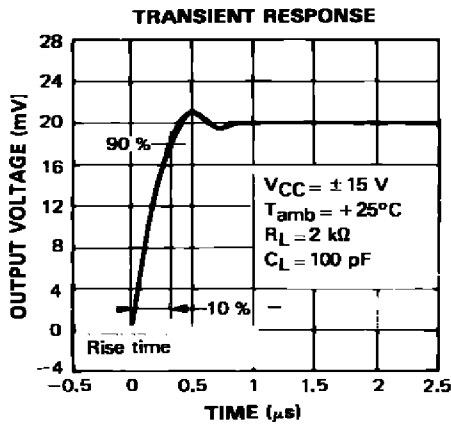
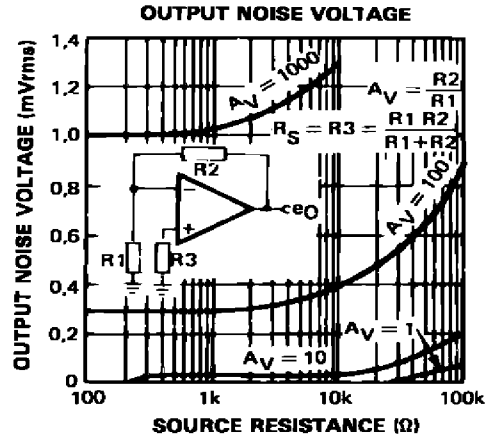
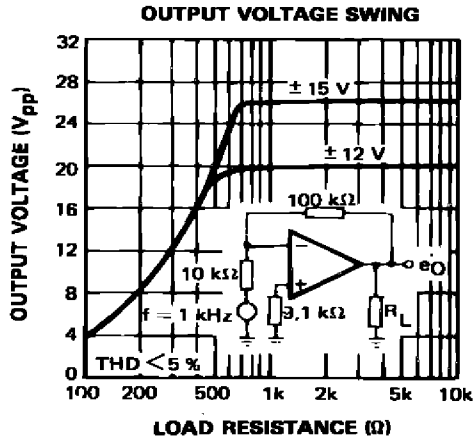

TYPICAL APPLICATIONS

LOW PASS FILTER

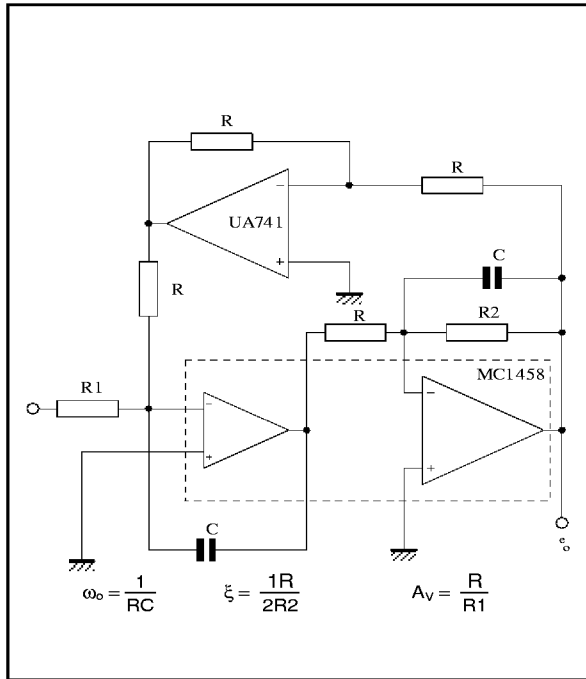

GIRATOR

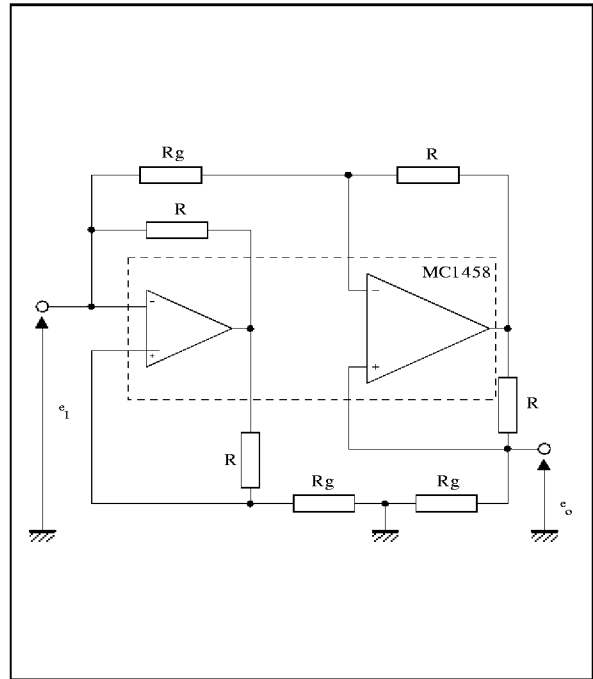

TURNABLE NOTCH FILTER

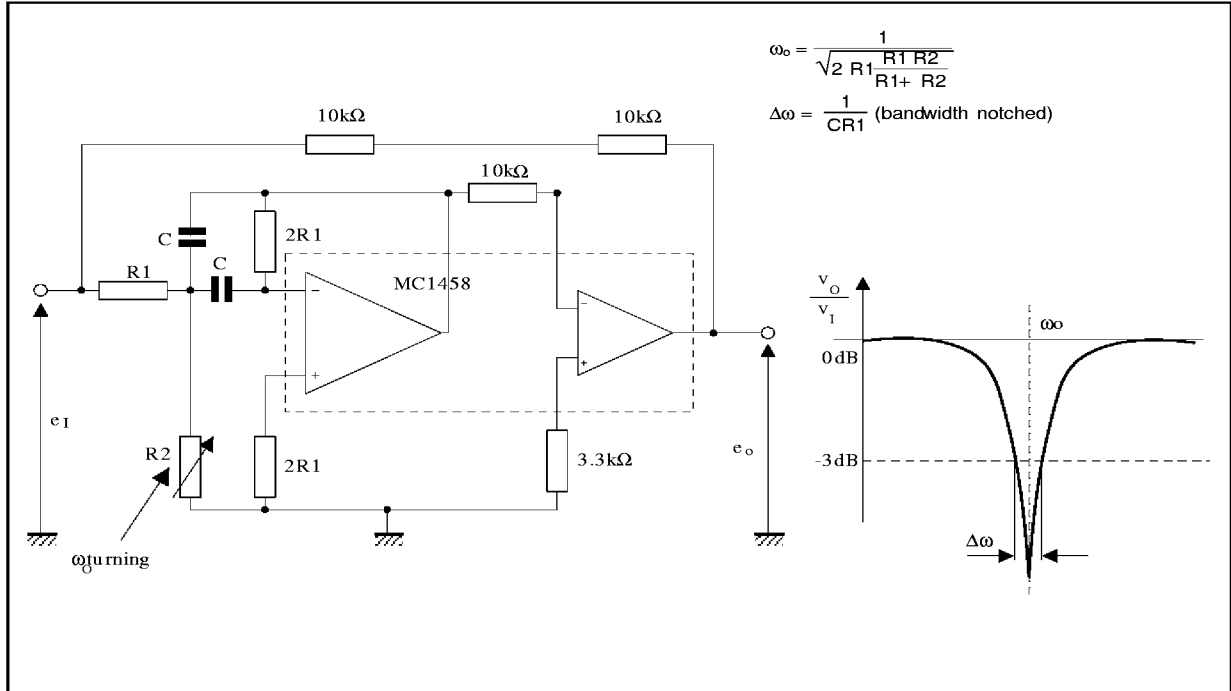

**PACKAGE MECHANICAL DATA**  
8 PINS - PLASTIC DIP

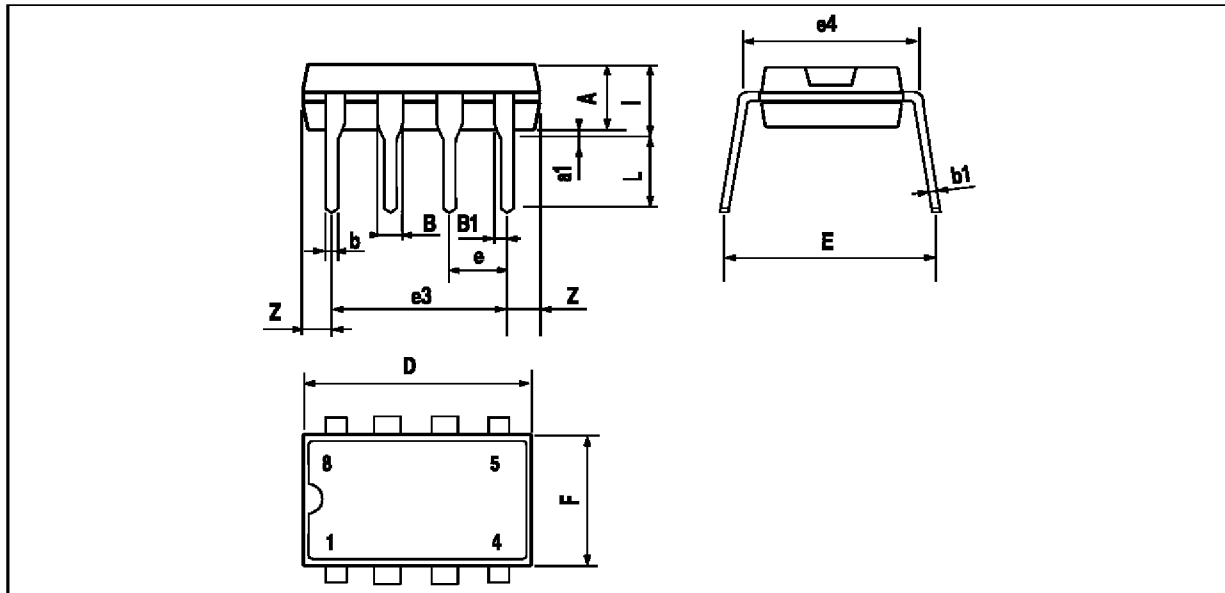

PM-DIP8.EPS

Dimensions	Millimeters			Inches		
	Min.	Typ.	Max.	Min.	Typ.	Max.
A		3.32			0.131	
a1	0.51			0.020		
B	1.15		1.65	0.045		0.065
b	0.356		0.55	0.014		0.022
b1	0.204		0.304	0.008		0.012
D			10.92			0.430
E	7.95		9.75	0.313		0.384
e		2.54			0.100	
e3		7.62			0.300	
e4		7.62			0.300	
F			6.6			0.260
i			5.08			0.200
L	3.18		3.81	0.125		0.150
Z			1.52			0.060

DIP8.TBL

MC1458 - MC1558

PACKAGE MECHANICAL DATA  
8 PINS - PLASTIC MICROPACKAGE (SO)

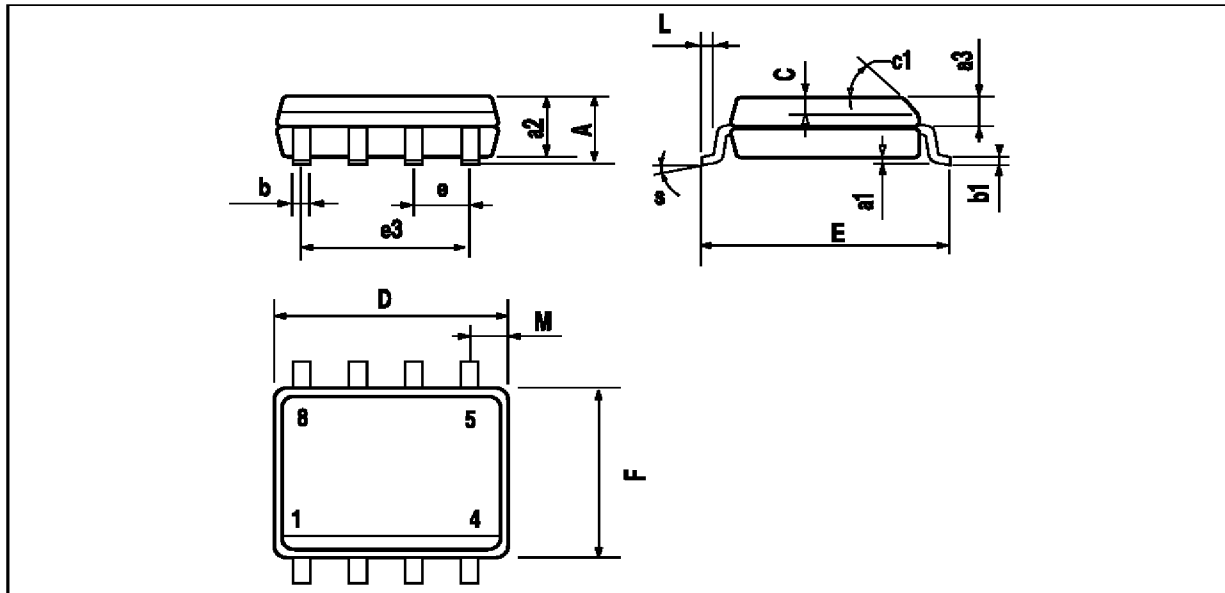

PM-S08.EPS

Dimensions	Millimeters			Inches		
	Min.	Typ.	Max.	Min.	Typ.	Max.
A			1.75			0.069
a1	0.1		0.25	0.004		0.010
a2			1.65			0.065
a3	0.65		0.85	0.026		0.033
b	0.35		0.48	0.014		0.019
b1	0.19		0.25	0.007		0.010
C	0.25		0.5	0.010		0.020
c1	45° (typ.)					
D	4.8		5.0	0.189		0.197
E	5.8		6.2	0.228		0.244
e		1.27			0.050	
e3		3.81			0.150	
F	3.8		4.0	0.150		0.157
L	0.4		1.27	0.016		0.050
M			0.6			0.024
S	8° (max.)					

SO8.TBL

Information furnished is believed to be accurate and reliable. However, SGS-THOMSON Microelectronics assumes no responsibility for the consequences of use of such information nor for any infringement of patents or other rights of third parties which may result from its use. No license is granted by implication or otherwise under any patent or patent rights of SGS-THOMSON Microelectronics. Specifications mentioned in this publication are subject to change without notice. This publication supersedes and replaces all information previously supplied. SGS-THOMSON Microelectronics products are not authorized for use as critical components in life support devices or systems without express written approval of SGS-THOMSON Microelectronics.

© 1997 SGS-THOMSON Microelectronics - Printed in Italy - All Rights Reserved

SGS-THOMSON Microelectronics GROUP OF COMPANIES  
Australia - Brazil - Canada - China - France - Germany - Hong Kong - Italy - Japan - Korea - Malaysia - Malta - Morocco  
The Netherlands - Singapore - Spain - Sweden - Switzerland - Taiwan - Thailand - United Kingdom - U.S.A.

ORDER CODE :

