

HA12179F

Audio Signal Processor for Car Deck and Cassette Deck
(Dolby B-type NR with PB Amp)

HITACHI

ADE-207-136
1st Edition
Apr. 1994

Description

HA12179F is silicon monolithic bipolar IC providing Dolby noise reduction system*, line mute, music sensor and PB equalizer system in one chip.

Functions

- Line mute × 2 channel
- PB equalizer × 2 channel
- Dolby B-NR × 2 channel
- Music sensor × 1 channel

Features

- Different type of PB equalizer characteristics selection (normal/chrome or metal) is available with fully electronic control switching built-in.
- Line mute ON/OFF is available.
- Changeable to Forward, Reverse-mode for PB head with fully electronic control switching built-in.
- Available to change music sensing level by external resistor.
- Music sensing level selection is available with fully electronic control switching built-in.
- Available to change frequency response of music sensor.
- NR-ON/OFF and REC/PB fully electronic control switching built-in.
- Pin compatible of HA12163 series except for 4 and 39 Pins.

* Dolby is a trademark of Dolby Laboratories Licensing Corporation.
A license from Dolby Laboratories Licensing Corporation is required for the use of this IC.

Ordering Information

	Package	PB-OUT level	REC OUT level	Dolby level
HA12179F	QFP 56	387.5 mVrms	300 mVrms	300 mVrms

PB-OUT level above shown is typical value when adjusting Dolby level at Rec-out with NR-off mode.

Block Diagram

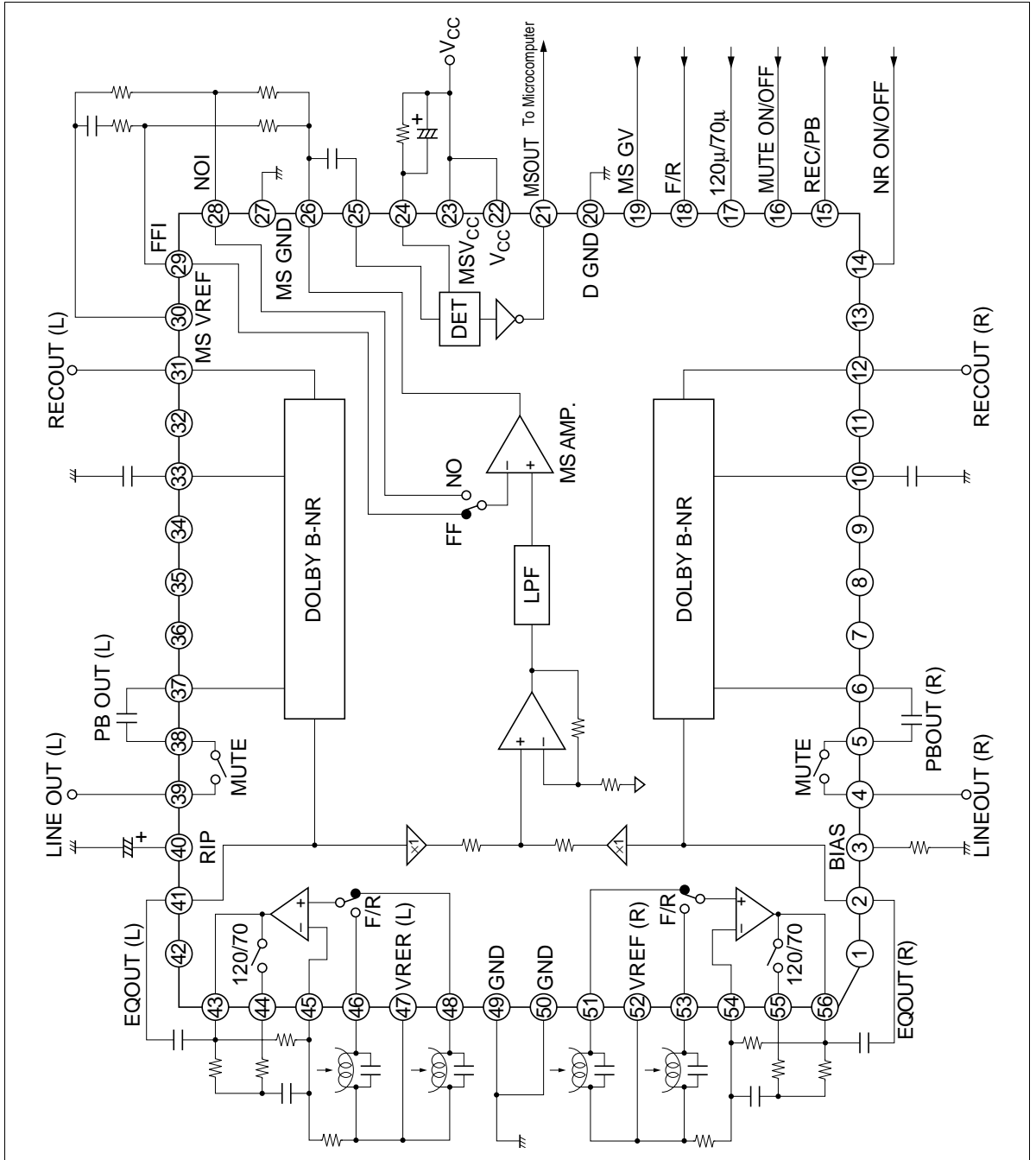

Pin Discription ($V_{CC} = 9\text{ V}$ Single supply, $T_a = 25^\circ\text{C}$, No signal, The value in the table show typical value.)

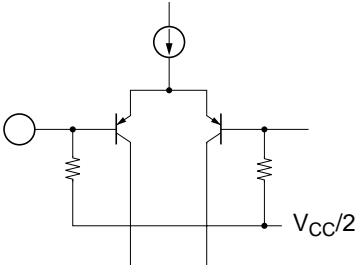
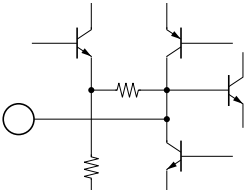
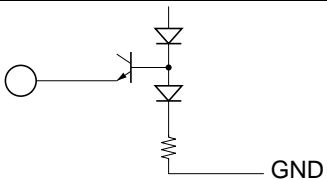
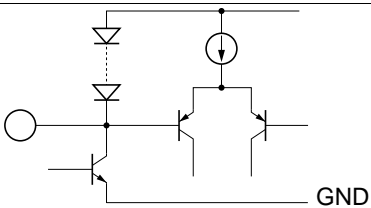
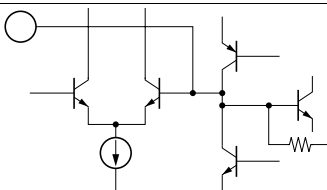
Pin No.	Terminal name	Zin	DC voltage	Equivalent circuit	Description
2 41	TAI	100 k	$V_{CC}/2$		Tape input
5 38	MUI				Mute circuit input
25	MSI				Music sensor rectifier input
10 33	NR DET	—	2.5 V		Time constant pin for rectifier
3	BIAS	—	0.28 V		Reference current input
24	MS DET	—	V_{CC}		Time constant pin for rectifier
40	RIP	—	$V_{CC}/2$		Ripple filter

Pin Discription ($V_{CC} = 9\text{ V}$ Single supply, $T_a = 25^\circ\text{C}$, No signal, The value in the table show typical value.) (cont)

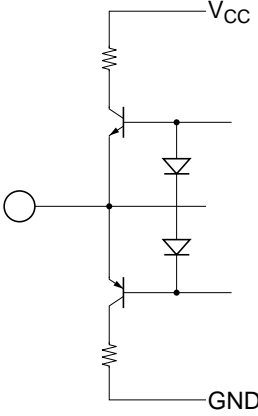
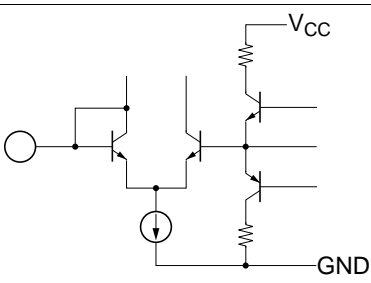
Pin No.	Terminal name	Zin	DC voltage Equivalent circuit	Description
43	EQ OUT	—	$V_{CC}/2$	Equalizer output
56				
6	PB OUT			Play back (Decode) output
37				
30	MS V_{REF}			Reference voltage buffer output
26	MA OUT			Music sensor amp. output
47	V_{REF}			Reference voltage buffer output
52				
12	REC OUT			Recording (Encode) output
31				
4	LINE OUT			Mute circuit output
39				
44	EQ OUT-M	—	$V_{CC}/2$	Equalizer output (Metal)
55				

Pin Discription ($V_{CC} = 9\text{ V}$ Single supply, $T_a = 25^\circ\text{C}$, No signal, The value in the table show typical value.) (cont)

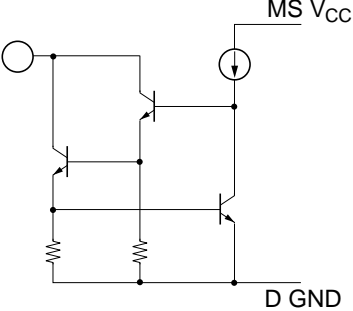
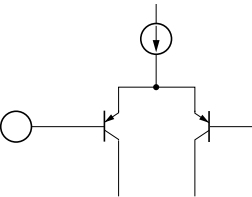
Pin No.	Terminal name	Zin	DC voltage	Equivalent circuit	Description
21	MS OUT	—	—		Music sensor output to MPU
22	V_{CC}	—	V_{CC}	—	Power supply
23	MS V_{CC}	—	V_{CC}	—	
20	D GND	—	0.0 V	—	Digital (Logic) ground
27	MS GND	—	—	—	Music sensor ground
49	GND	—	—	—	Ground
50		—	—	—	
48	FIN	—	$V_{CC}/2$		PB-EQ input for forward
51		—	—	—	
46	RIN	—	—	—	PB-EQ input for reverse
53		—	—	—	
45	NFI	—	—	—	Negative feedback terminal of PB-EQ amp.
54		—	—	—	
28	NOI	—	—	—	Negative feedback input for normal speed
29	FFI	—	—	—	Negative feedback input for FF or REW

Pin Discription ($V_{CC} = 9\text{ V}$ Single supply, $T_a = 25^\circ\text{C}$, No signal, The value in the table show typical value.) (cont)

Pin No.	Terminal name	Zin	DC voltage	Equivalent circuit	Description
14	ON/OFF	122 k	—		Mode control input
15	REC/PB				
16	MUTE				
17	120 μ /70 μ				
18	F/R				
19	MS GV				
1	NC				No connection
7					
8					
9					
11					
13					
32					
34					
35					
36					
42					

Absolute Maximum Ratings

Item	Symbol	Ratings	Unit	Note
Supply voltage	V_{CC} max	16	V	
Power dissipation	P_T	400	mW	Ta 85 °C
Operating temperature	Topr	-40 to +85	°C	
Storage temperature	Tstg	-55 to +125	°C	

Note: Operating voltage range is

$$V_{CC} = 6.8 \text{ to } 16.0 \text{ V}$$

Electrical Characteristics (Ta = 25 °C Dolby Level 300 mVrms, V_{CC} = 9.0 V)

Item	Symbol	Min	Typ	Max	Unit	Test conditions	Remark
Quiescent current	I _Q	6.5	12.0	17.5	mA	PB mode, NR-ON, 70μ, MUTE-OFF No signal	
Input amp. gain	GvIA TAI	21.2	22.2	23.2	dB	Vin = 0 dB, f = 1 kHz	
B-type encode	ENC-2 k (1)	2.8	4.3	5.8	dB	Vin = -20 dB, f = 2 kHz	
boost	ENC-2 k (2)	7.0	8.5	10.0		Vin = -30 dB, f = 2 kHz	
	ENC-5 k (1)	1.7	3.2	4.7		Vin = -20 dB, f = 5 kHz	
	ENC-5 k (2)	6.7	8.2	9.7		Vin = -30 dB, f = 5 kHz	
Signal handling	V _O max	12.0	13.0	—	dB	THD = 1%, f = 1 kHz	*1
Signal to noise ratio	S/N	64.0	70.0	—	dB	Rg = 5.1 k , CCIR/ARM	
THD	THD	—	0.05	0.3	%	Vin = 0 dB, f = 1 kHz	
Channel separation	CT RL (1)	65.0	80.0	—	dB	Vin = 0 dB, f = 1 kHz	TAI IN
	CT RL (2)	50.0	60.0	—		Vin = 0.6 mVrms, f = 1 kHz	EQ IN
Mute attenuation	MUTE ATT	70.0	85.0	—		Vin = 0 dB, f = 1 kHz	TAI IN
PB-EQ gain	Gv EQ 1 k	37.0	40.0	43.0	dB	Vin = 0.6 mVrms, f = 1 kHz	120 μ
	Gv EQ 10 k (1)	33.0	36.0	39.0		Vin = 0.6 mVrms, f = 10 kHz	
	Gv EQ 10 k (2)	29.0	32.0	35.0			70 μ
PB-EQ maximum output	VoM	300	600	—	mVrms	THD = 1%, f = 1 kHz	*1
PB-EQ THD	THD-EQ	—	0.05	0.3	%	Vin = 0.6 mVrms, f = 1 kHz	
Noise voltage level converted in input	V _N	—	0.7	1.5	μVrms	Rg = 680 , DIN-AUDIO	
MS sensing level	V _{ON} (1)	-36.0	-32.0	-28.0	dB	f = 5 kHz, Normal speed	
	V _{ON} (2)	-18.0	-14.0	-10.0		f = 5 kHz, High speed	
MS output low level	V _{OL}	—	1.0	1.5	V		
MS output leak current	I _{OH}	—	0.0	2.0	μA		
Control voltage	V _{IL}	-0.2	—	1.0	V		
	V _{IH}	3.5	—	5.3			

Note: 1 V_{CC} = 6.8 V

Test Circuit

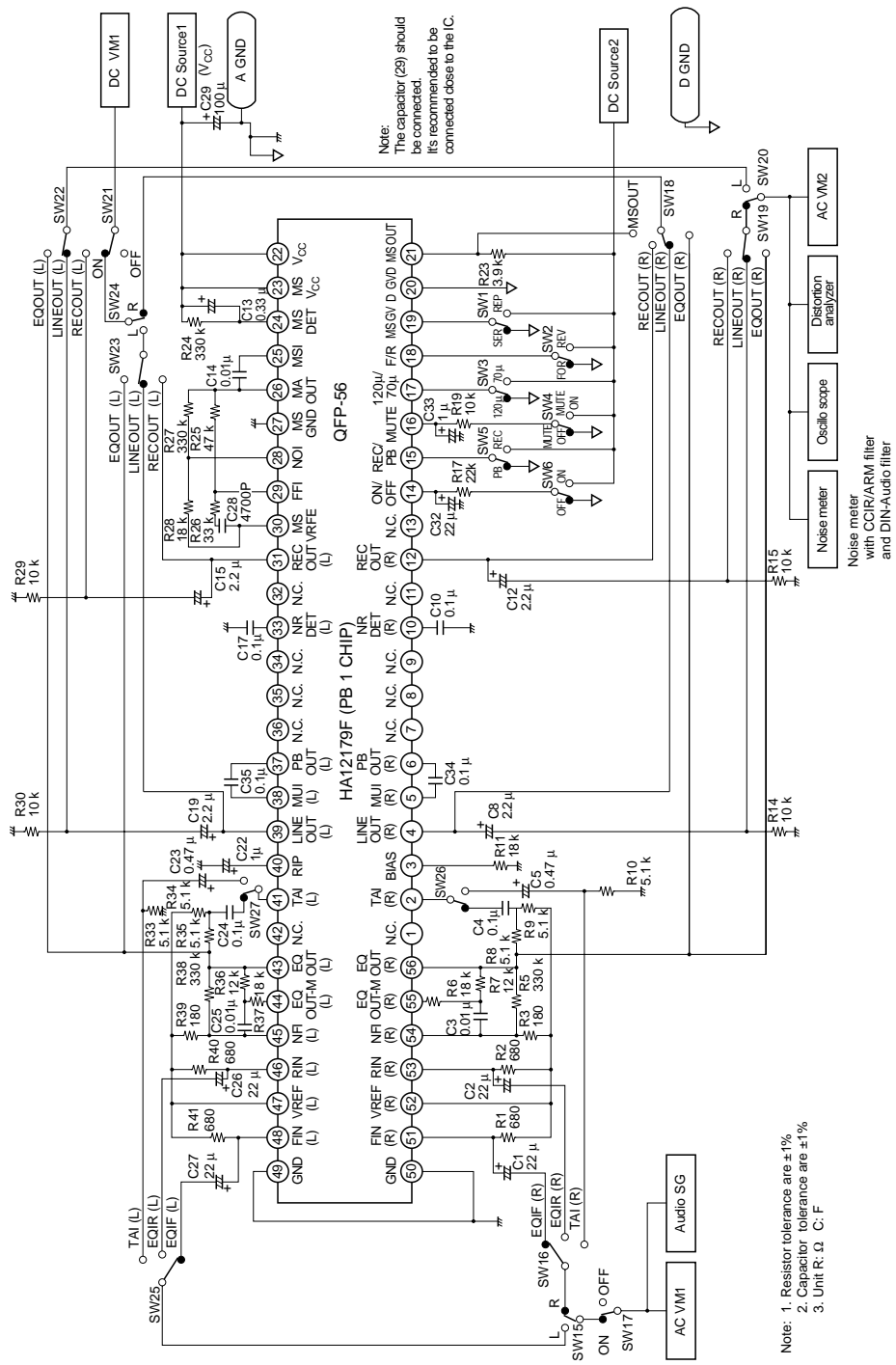

- Note: 1. Resistor tolerance are ±1%
 2. Capacitor tolerance are ±1%
 3. Unit R: Ω, C: F

Application Note

Power Supply Range

Table 1 Supply Voltage

HA12179F	
Single supply	6.8 V to 16.0 V

HA12179F is designed to operate on single supply. Please consult to HITACHI sales engineers when it will use the split supply.

1. The lower limit of supply voltage depends on the line output reference level.
The minimum value of the overload margin is specified as 12 dB by Dolby Laboratories.
2. In the reverse-voltage conditions such as 'D-GND is higher than VCC' or 'D-GND is lower than GND', excessive current flows into the D-GND to destroy this IC. To prevent such destruction, pay attention to the followings on using. Therefore, Short-circuit the D-GND and GND directory on the board mounting this IC.

Reference Voltage

For the single supply operation this device provides the reference voltage of half the supply voltage that is the signal grounds. As the peculiarity of these devices, the capacitor for the ripple filter is very small about 1/100 compared with their usual value. The Reference voltage are provided for the left channel and the right channel separately. The block diagram is shown as figure 1.

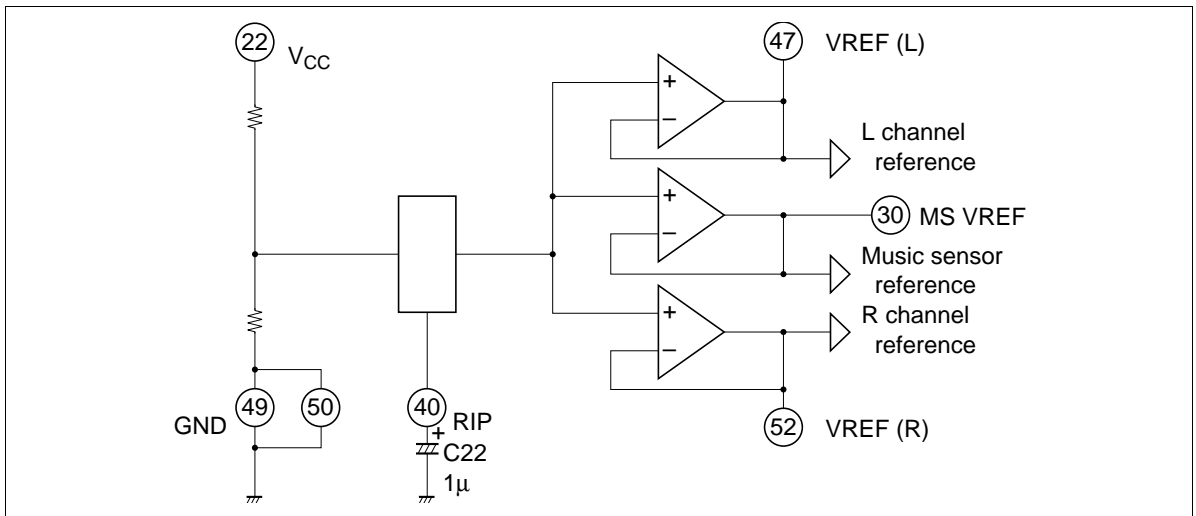

Figure 1 The Block Diagram of Reference Voltage Supply

Operating Mode Control

HA12179F provides electronic switching circuits. And each operating mode control are controlled by parallel data (DC voltage).

Table 2 Threshold Voltage (V_{TH})

Pin No.	Lo	Hi	Unit	Test condition
14 15 16 17 18 19	-0.2 to 1.0	3.5 to 5.3	V	Input Pin  Measure

Table 3 Switching Truth Table

Pin No.	Lo	Hi
14	NR-OFF	NR-ON
15	PB	REC
16	MUTE-OFF	MUTE-ON
17	120 μ (NORMAL)	70 μ (METAL or CHROME)
18	FORWARD	REVERSE
19	SER (FF or REV)	REP (NORMAL SPEED)

- Notes:
1. Each pins are on pulled down with 100 k internal resistor. Therefore, it will be low-level when each pins are open.
 2. Over shoot level and under shoot level of input signal must be the standardized (High: 5.3 V, Low: -0.2 V)
 3. Reducing pop noise is so much better for 10 k to 22 k resistor and 1 μ F to 22 μ F capacitor shown Fig 2. But the resistor connected to MUTE terminal (pin 16) should be under 10 k .

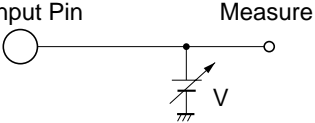
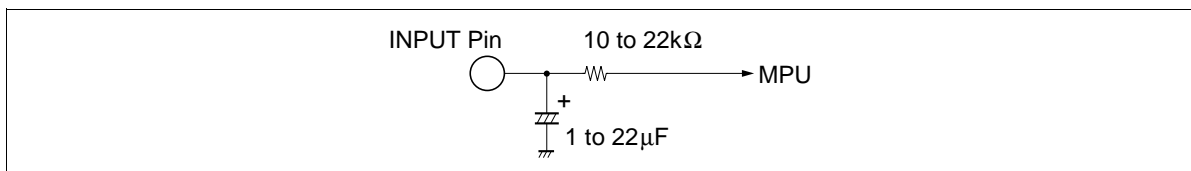

Figure 2 Interface for Reduction of Pop Noise

Input Block Diagram and Level Diagram

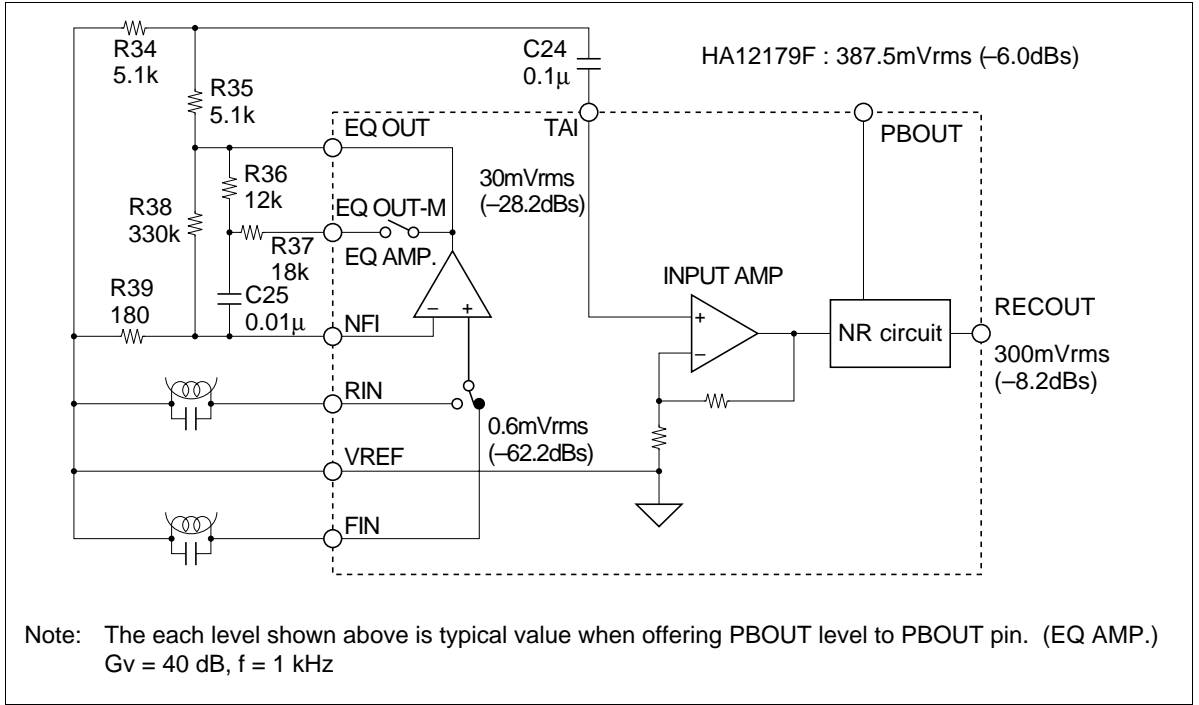

Figure 3 Input Block Diagram

Adjustment of Playback Dolby Level

After replace R34 and R35 with a half-fix volume of 10 k , adjust RECOUT level to be Dolby level with playback mode.

Note on Connecting with Tape Head to IC

This IC has no internal resistor to give the DC bias current to equalizer amp., therefore the DC bias current will give through the head. This IC provides the Vref buffer output pin for Rch and Lch separately (has two Vref terminal). In case of use that the Rch and Lch reference of head are connected commonly, please use one of Vref terminals of IC (47 pin or 52 pin) for head reference.

If both 47 pin and 52 pin of IC are connected, rush current give the great damage to IC. The application circuit is shown in figure 4.

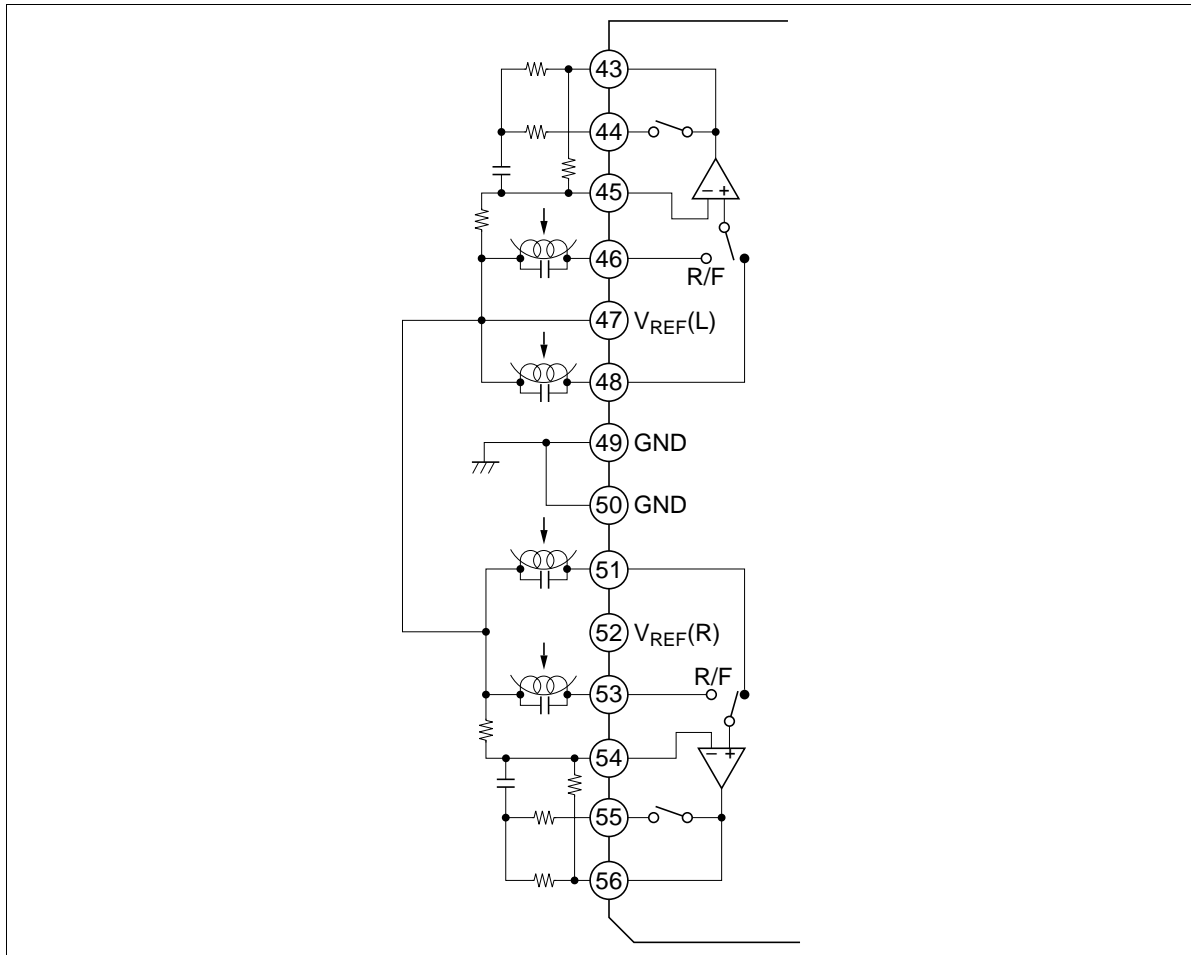

Figure 4 Application Circuit

The Sensitivity Adjustment of Music Sensor

Adjusting MS AMP. gain by external resistor, the sensitivity of music sensor can set up.

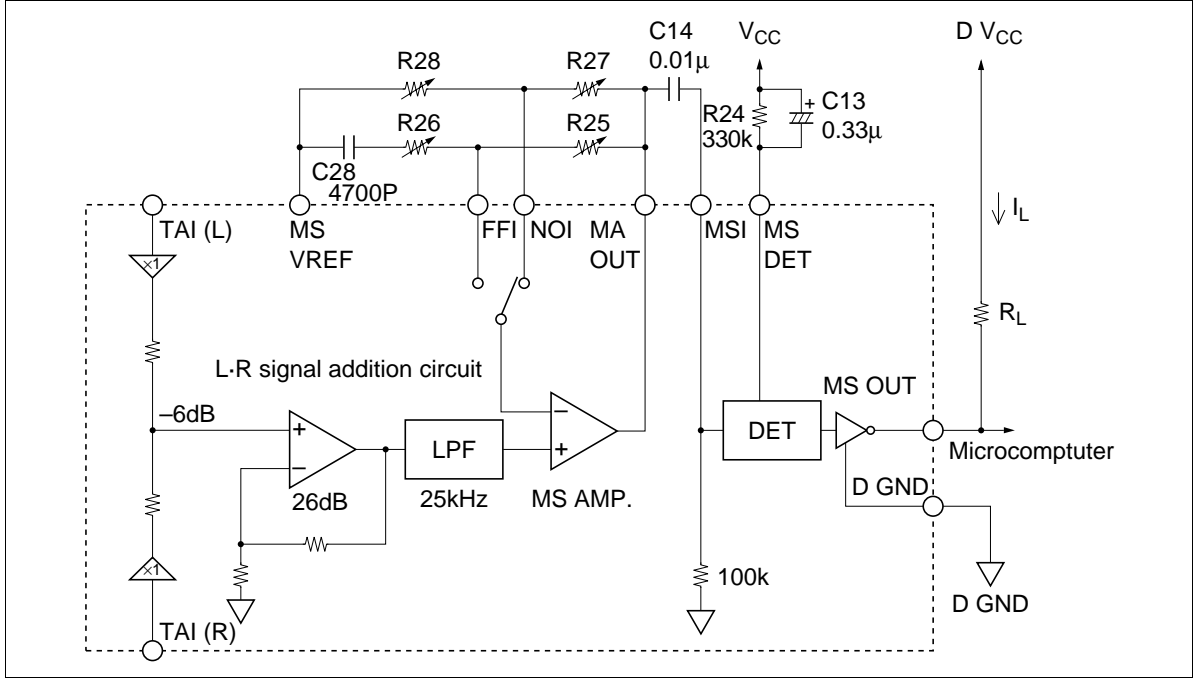

Figure 5 Music Sensor Block Diagram

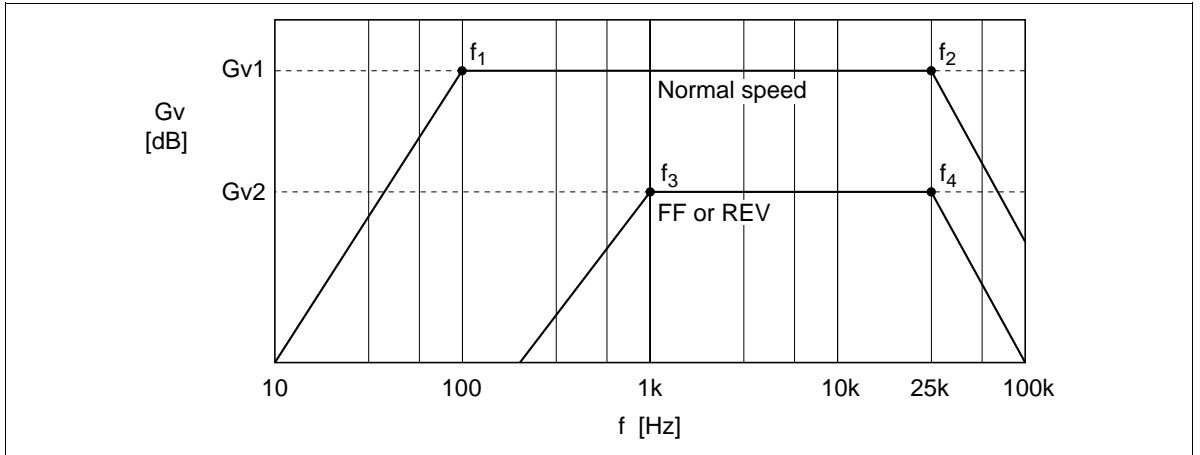

Figure 6 Frequency Response

- Normal mode

$$Gv1 = 20 \log \left(1 + \frac{R27}{R28} \right) [\text{dB}]$$

$$f1 = \frac{1}{2 \cdot \pi \cdot C14 \cdot 100 \text{ k}} [\text{Hz}], f2 = 25 \text{ k} [\text{Hz}]$$

- FF or REW mode

$$Gv2 = 20 \log \left(1 + \frac{R25}{R26} \right) [\text{dB}]$$

$$f3 = \frac{1}{2 \cdot \pi \cdot C28 \cdot R26} [\text{Hz}], f4 = 25 \text{ k} [\text{Hz}]$$

A standard level of TAI pin is 30 mVrms and the gain for TAI to MS AMP input is 10times, therefore, the other channel sensitivity of music sensor (S) is computed by the formula mentioned below.

$$S = 20 \log \left(\frac{C}{30} \cdot \frac{1}{10 \cdot A} \right) [\text{dB}]$$

A = MS AMP. gain (B dB)

C = The sensing level of music sensor

$$S = -7.3 - B [\text{dB}] \quad C = 130 \text{ mVrms (typ.)}$$

S is 6 dB up in case of the both channels.

Music Sensor Time Constant

- Sensing no signal to signal (Attack) is determined by C13.
0.01 μF to 1 μF capacitor C13 can be applicable.
- Sensing signal to no signal (Recovery) is determined by C13 and R24, however preceding (Attack), 100 k to 1 M R24 can be applicable.

Music Sensor Output (MS OUT)

As for the internal circuit of music sensor block, music sensor out pin is connected to the collector of NPN Type directly, therefore, output level will be “high” when sensing no signal. And output level will be “low” when sensing signal.

Connection with microcomputer, design I_L at 1mA typ.

$$I_L = \frac{DV_{CC} - MSOUT_{Lo} *}{R_L}$$

* $MSOUT_{Lo}$: Sensing signal (about 1 V)

- Notes:
1. Supply voltage of MS OUT pin must be less than V_{CC} voltage.
 2. MS V_{CC} pin and V_{CC} pin are required the same voltage.

The Tolerances of External Components for Dolby NR-block

For adequate Dolby NR tracking response, take external components shown below.

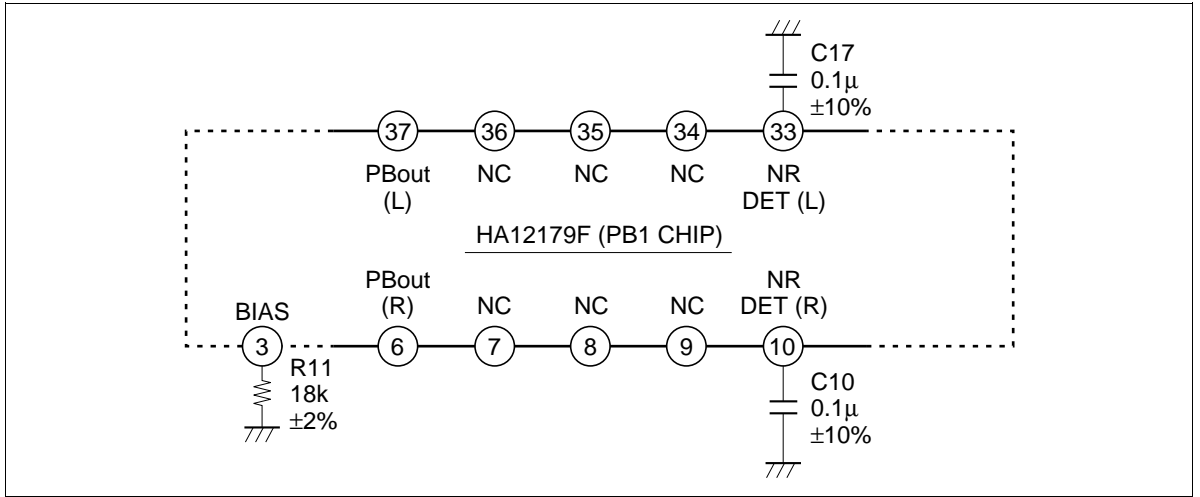

Figure 7 Tolerances of External Components

PB Equalizer for Double Speed

PB equalizer can be design for double speed by using external components shown in figure 8. Application data is shown in figure 9.

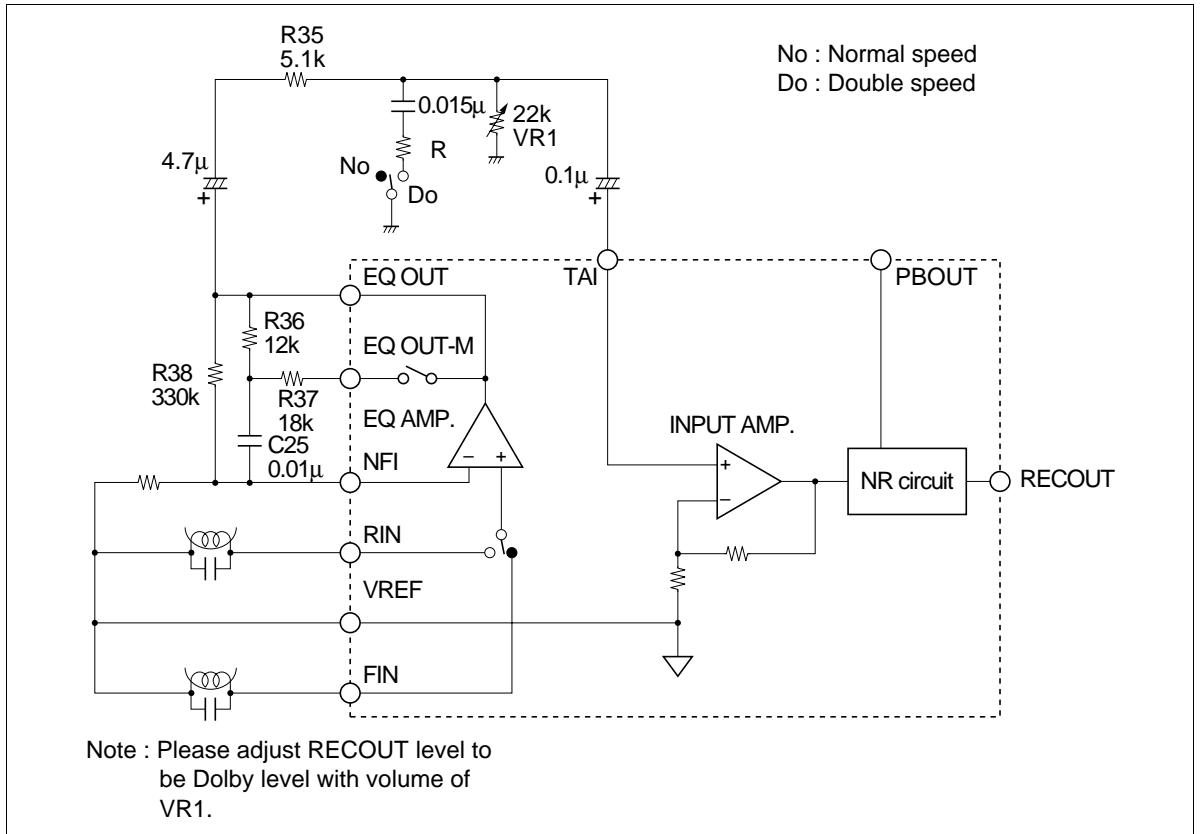
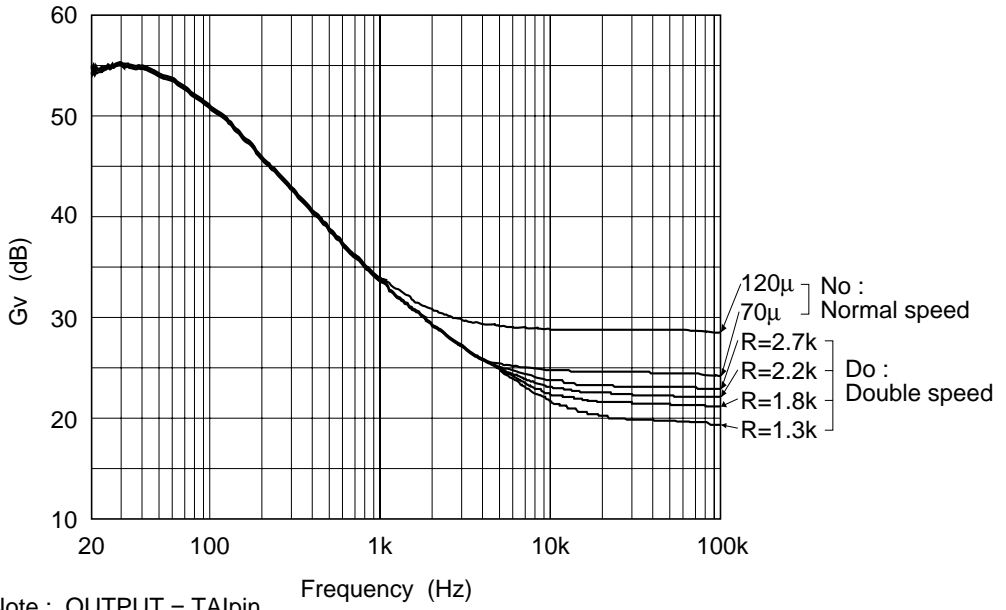
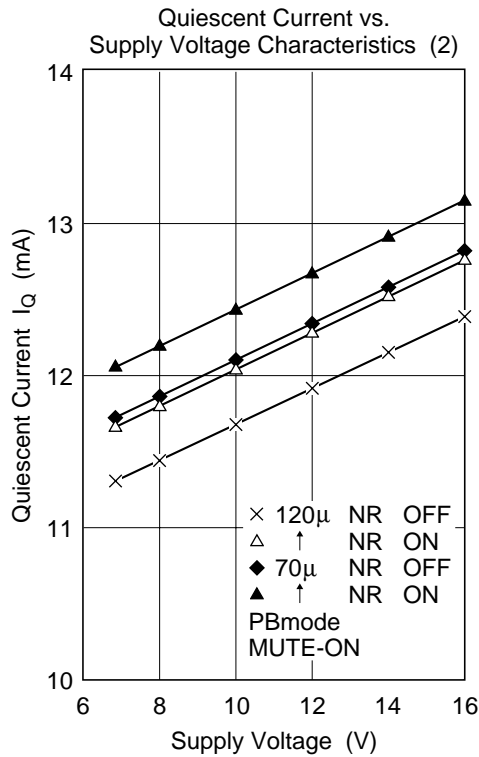
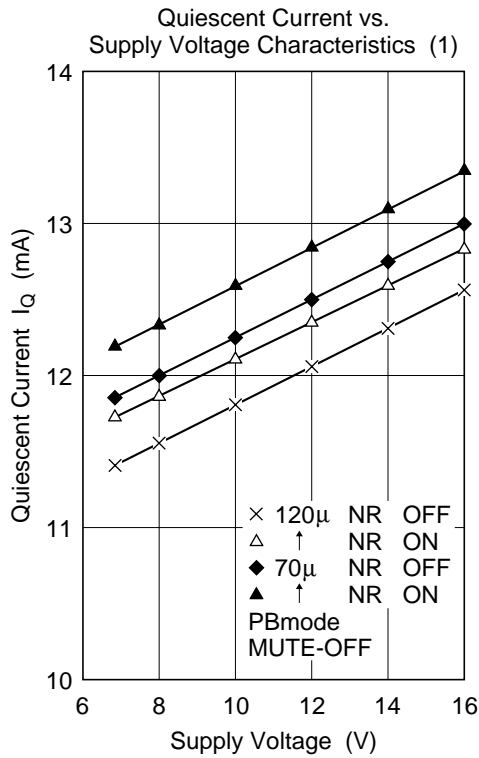

Figure 8 Application Circuit for Double Speed



Note : OUTPUT = TAlpin

Figure 9 Application Data



Gain vs. Frequency Characteristics (PBmode)

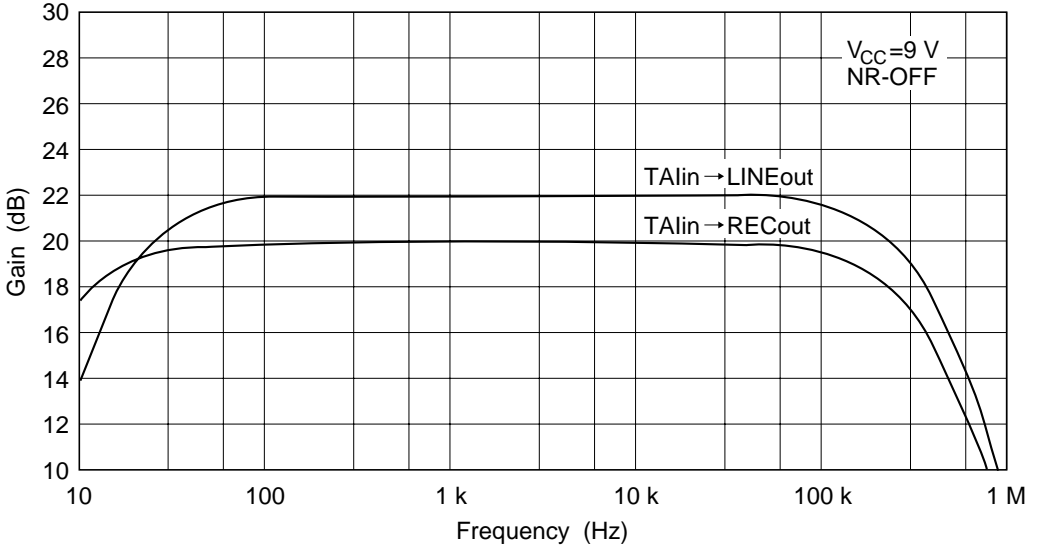

Gain vs. Frequency Characteristics (RECmode)

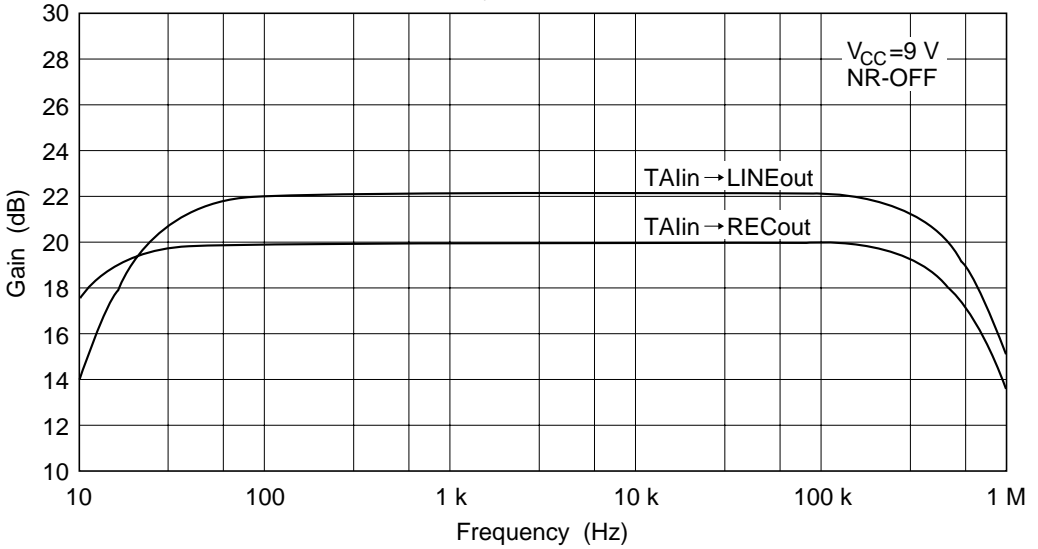

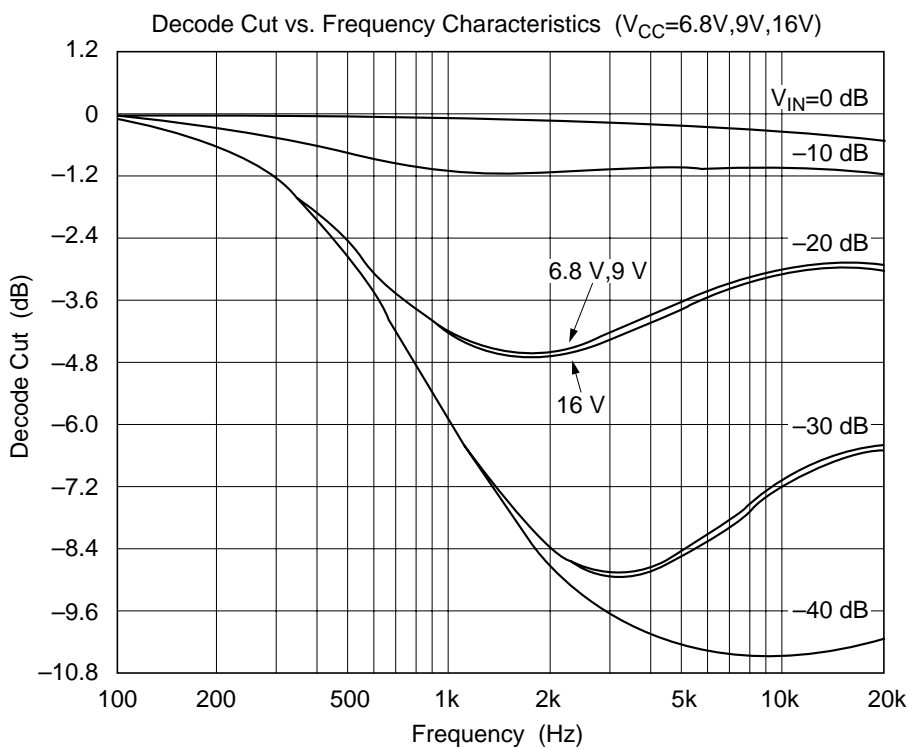
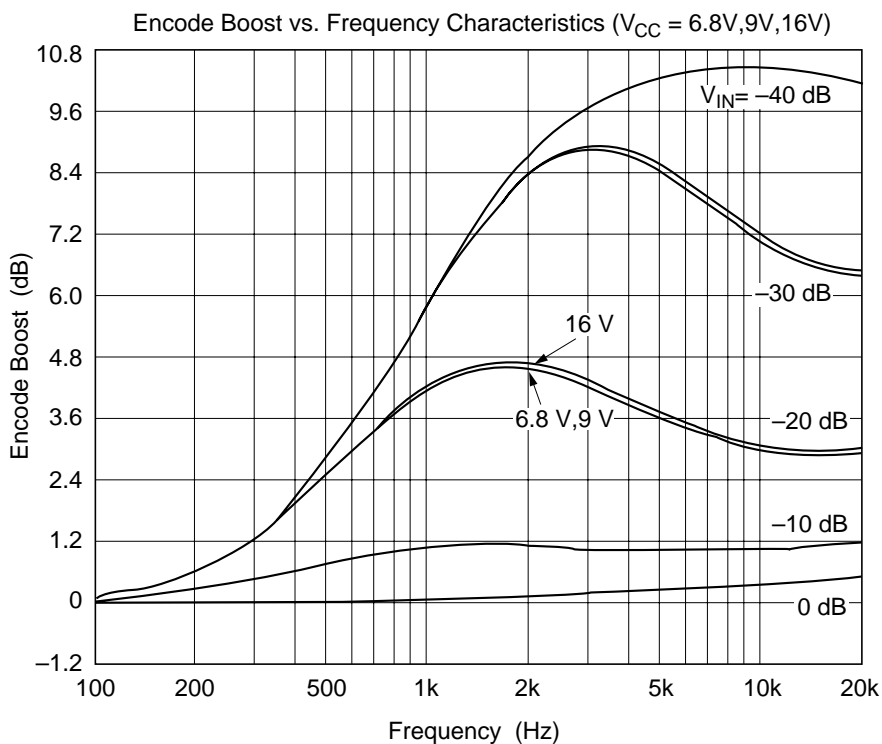

Maximum Output Level vs. Supply Voltage Characteristics (1)

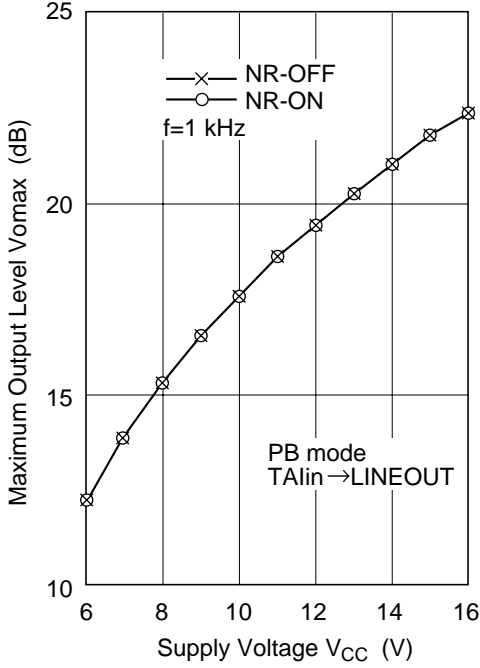

Maximum Output Level vs. Supply Voltage Characteristics (2)

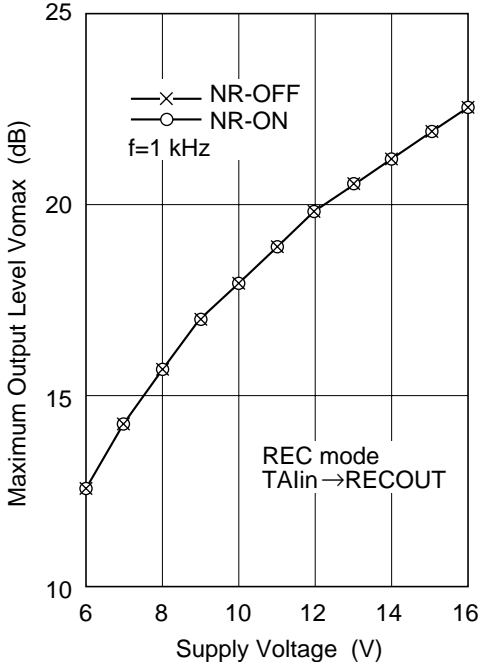

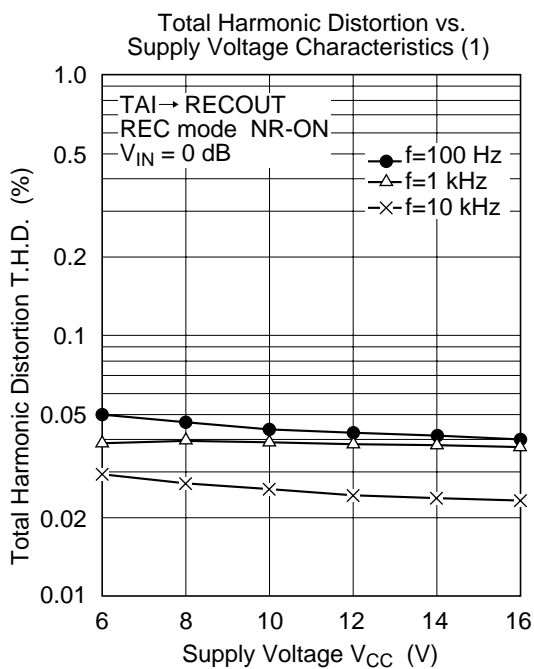
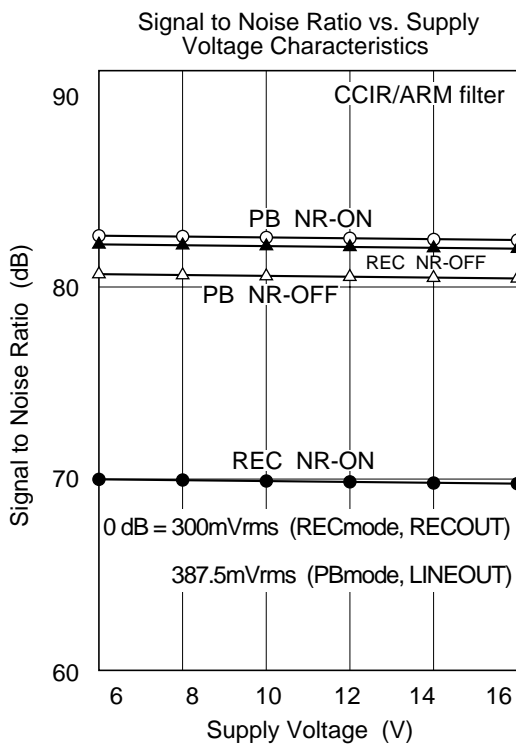

Total Harmonic Distortion vs. Supply Voltage Characteristics (2)

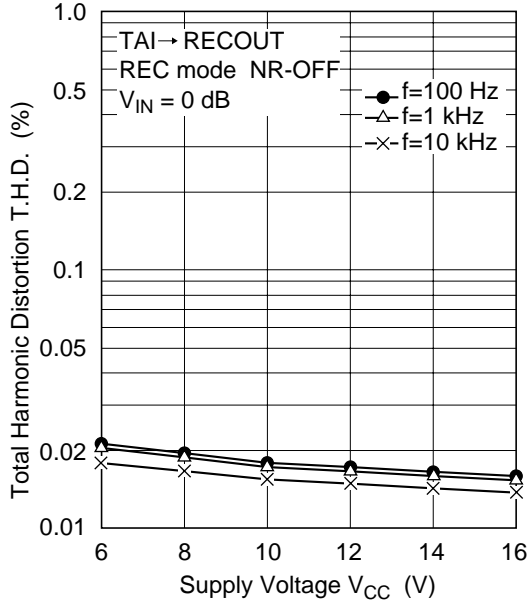

Total Harmonic Distortion vs. Supply Voltage Characteristics (3)

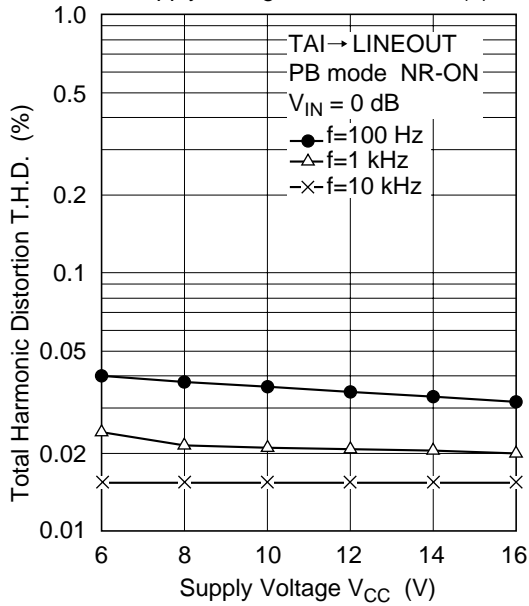

Total Harmonic Distortion vs. Supply Voltage Characteristics (4)

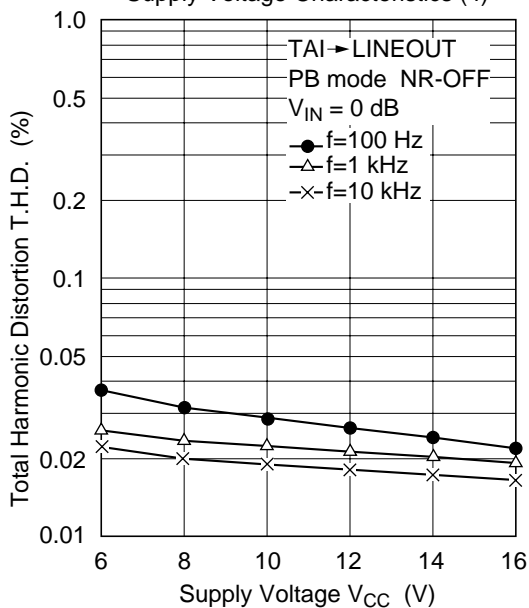

Total Harmonic Distortion vs. Output Level Characteristics (1)

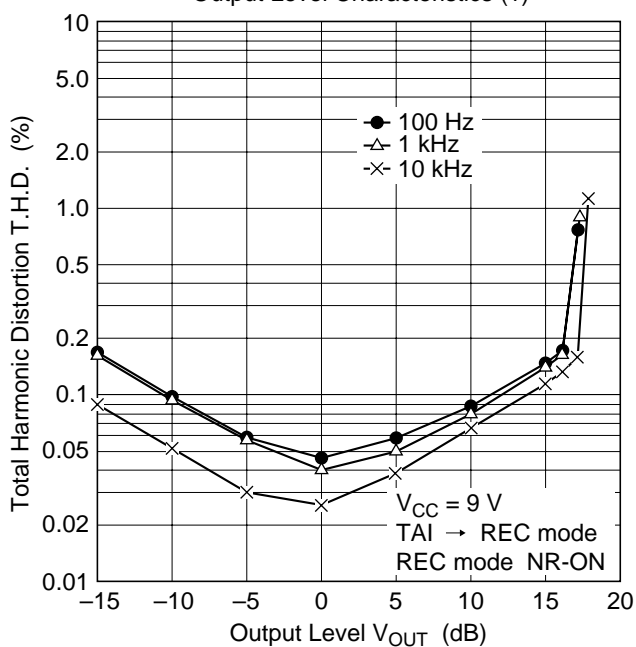

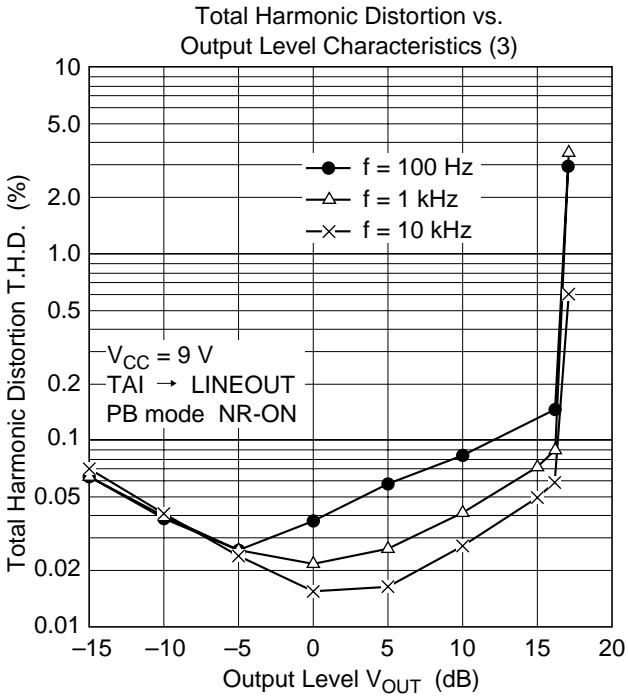
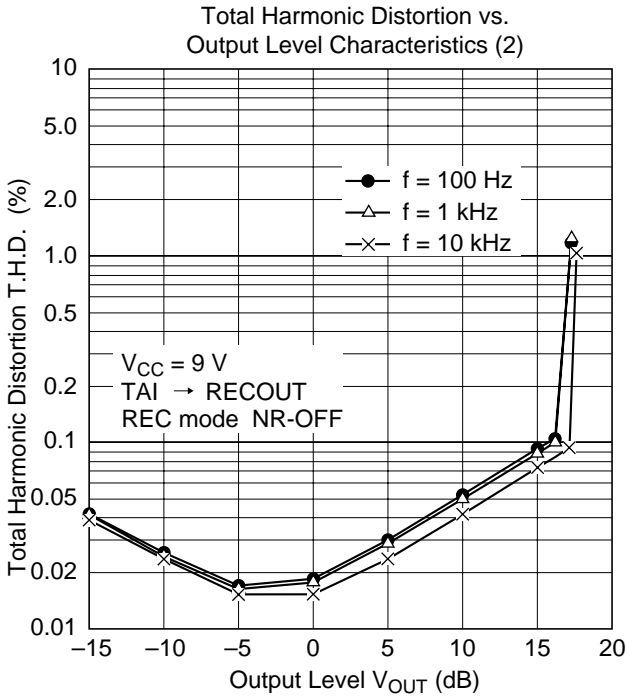

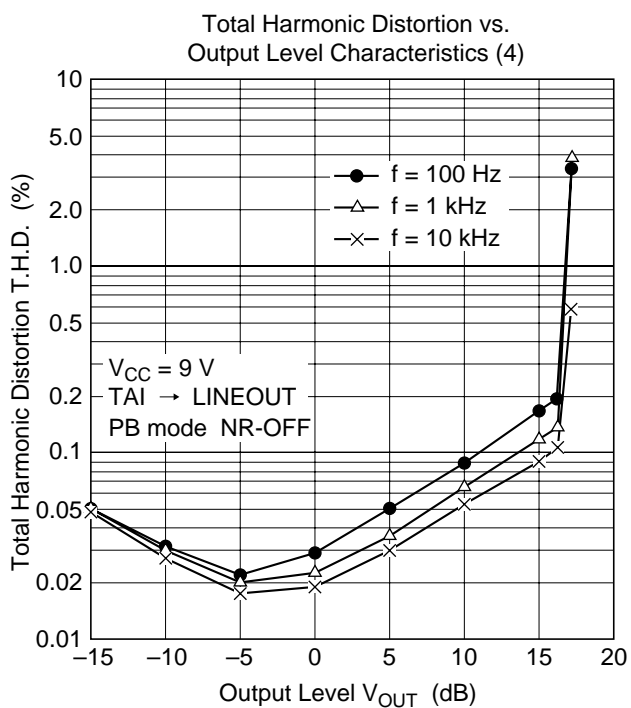

Total Harmonic Distortion vs. Frequency Characteristics (1)

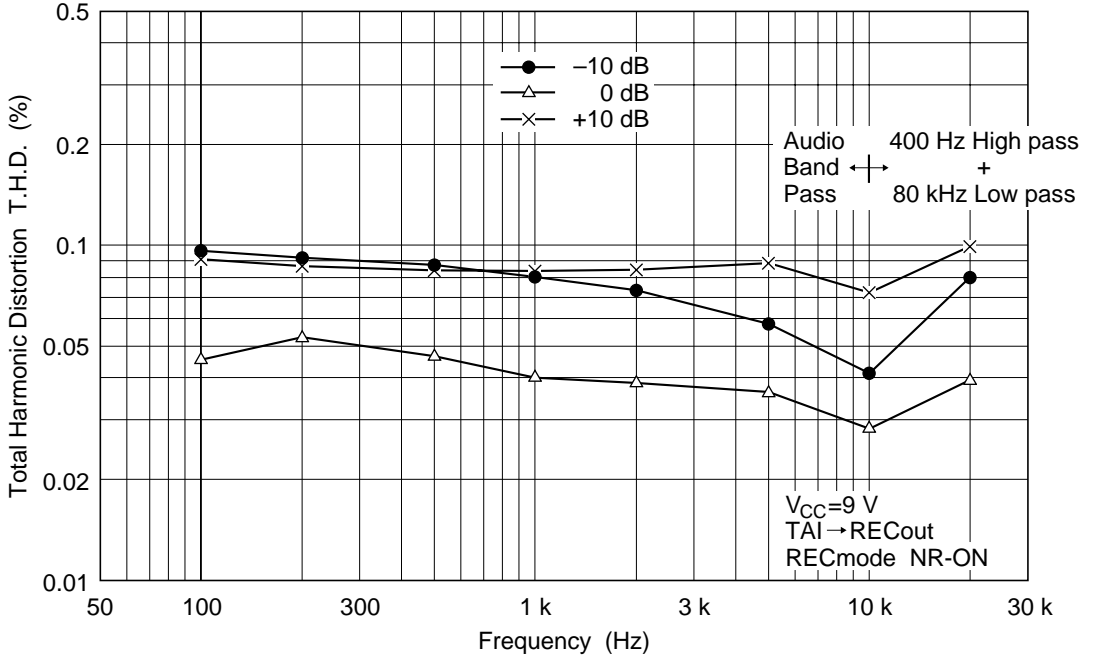

Total Harmonic Distortion vs. Frequency Characteristics (2)

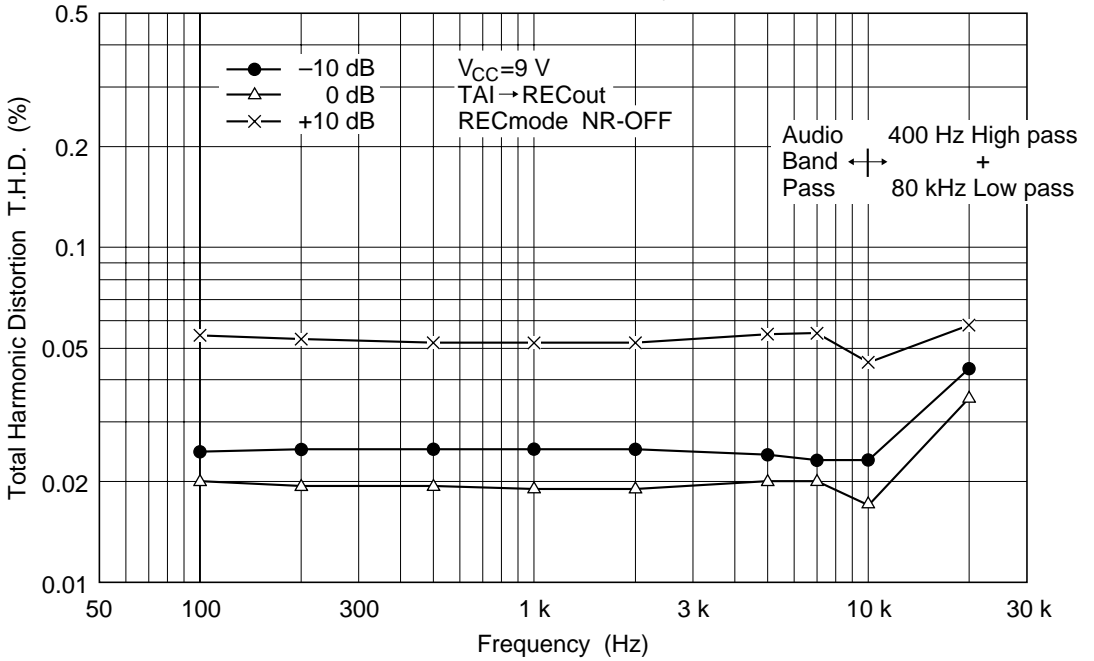

Total Harmonic Distortion vs. Frequency Characteristics (3)

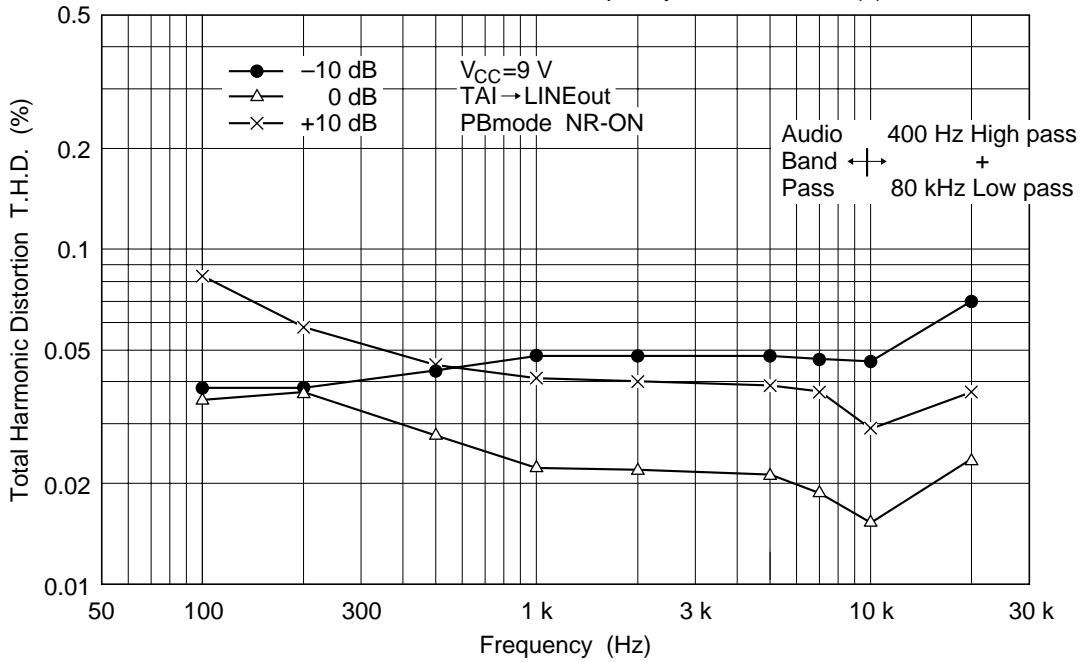

Total Harmonic Distortion vs. Frequency Characteristics (4)

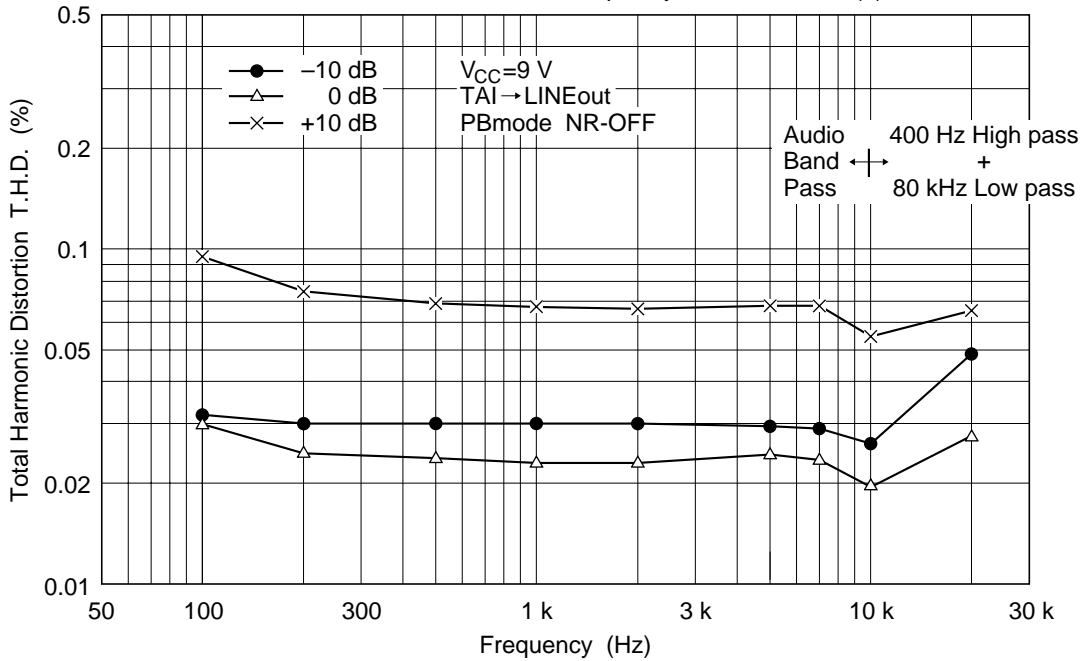

Channel Separation vs. Frequency Characteristics (1)

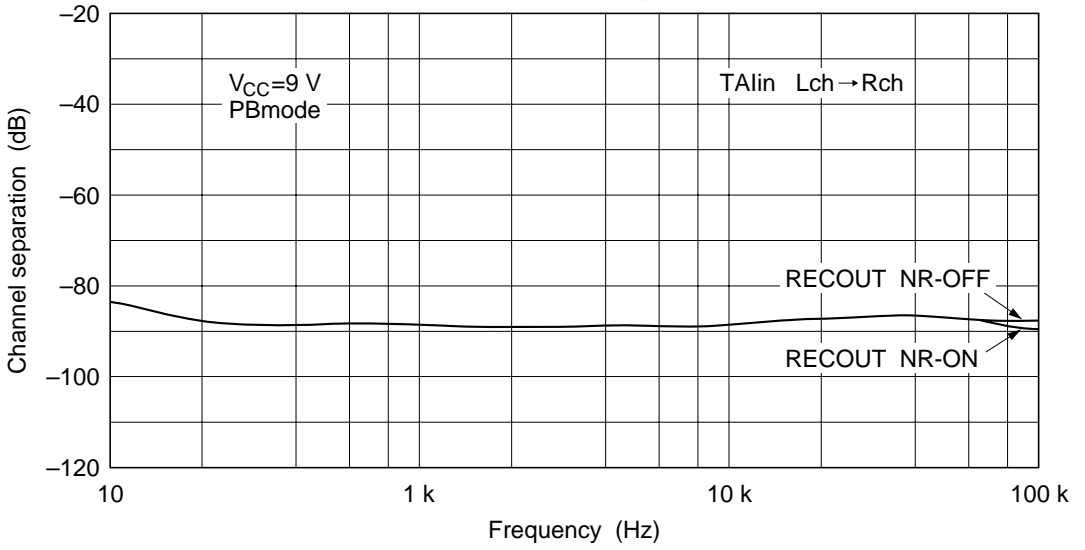

Channel Separation vs. Frequency Characteristics (2)

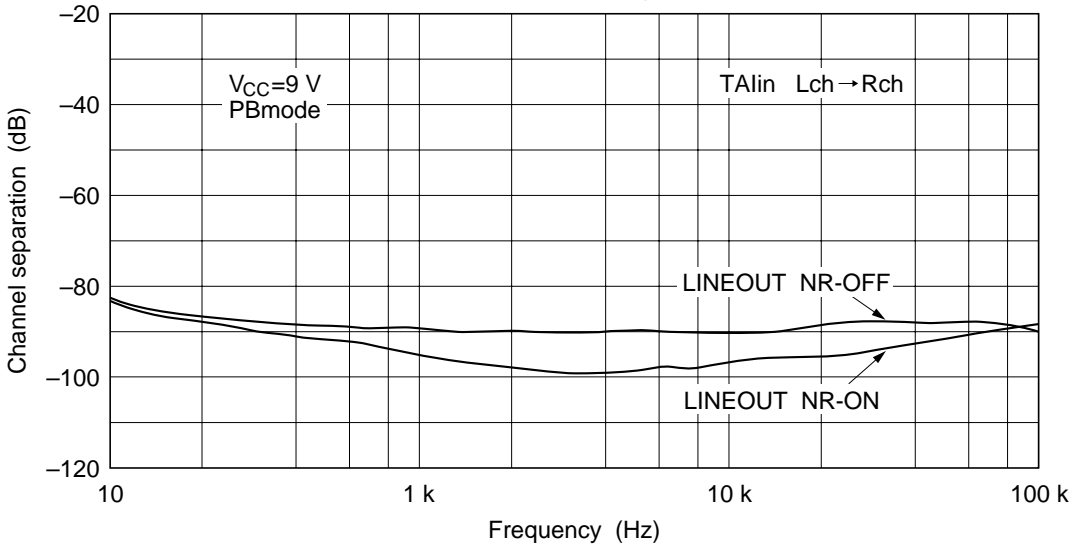

Channel Separation vs. Frequency Characteristics (3)

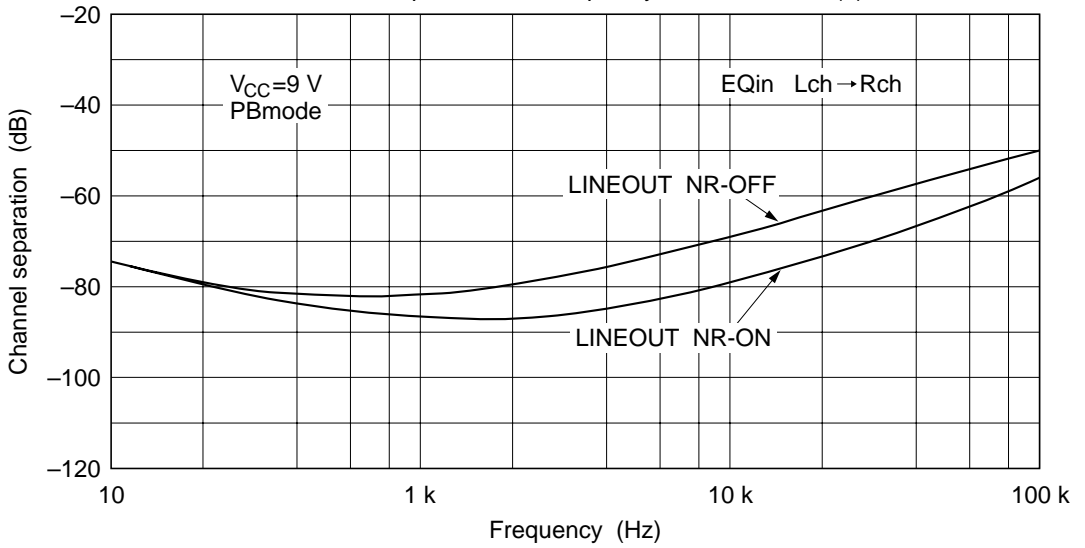

Channel Separation vs. Frequency Characteristics (4)

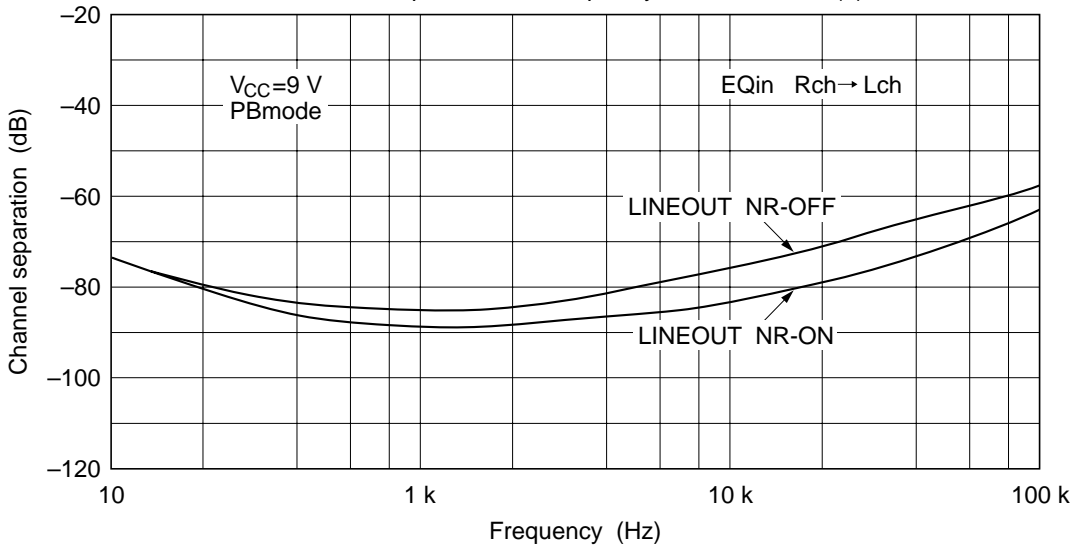

Crosstalk vs. Frequency Characteristics (1)

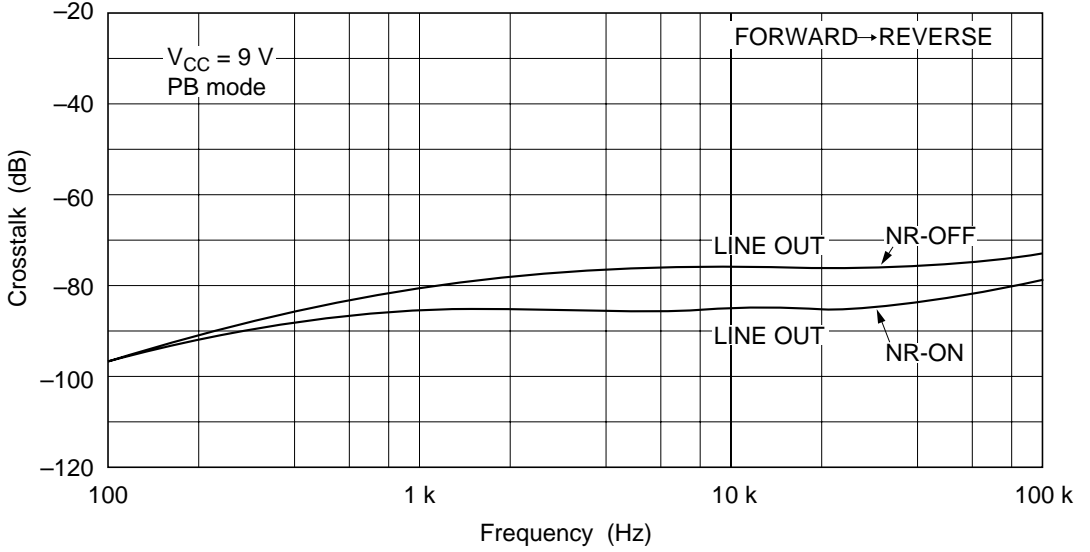

Crosstalk vs. Frequency Characteristics (2)

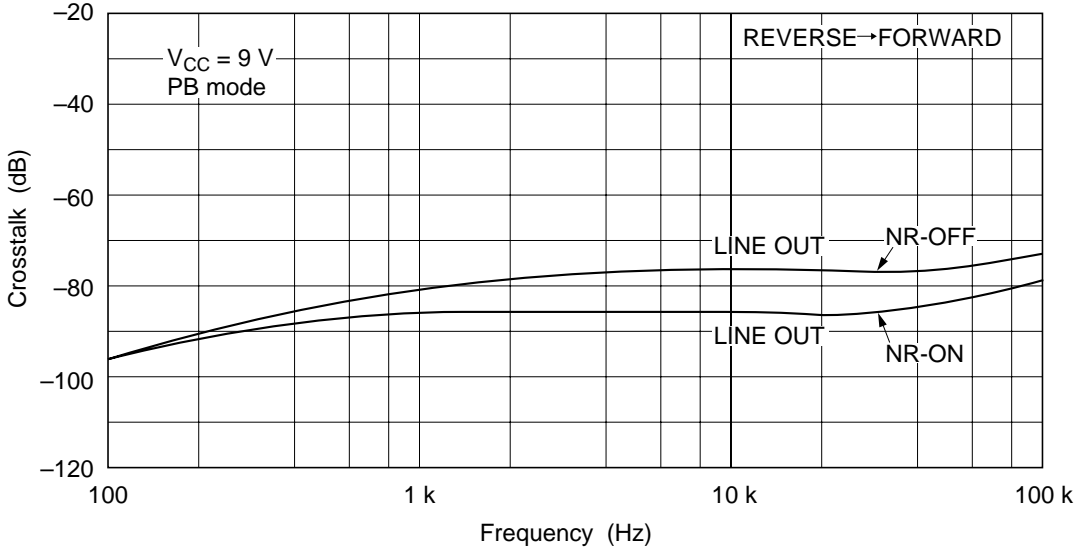

MUTE Attenuation vs. Frequency Characteristics

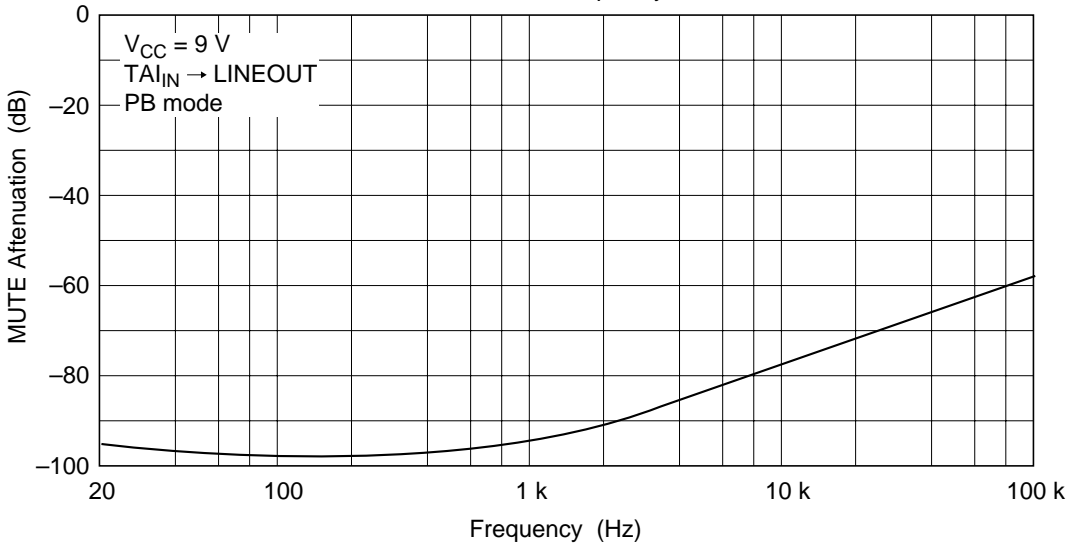

Ripple Rejection Ratio vs. Frequency Characteristics (1)

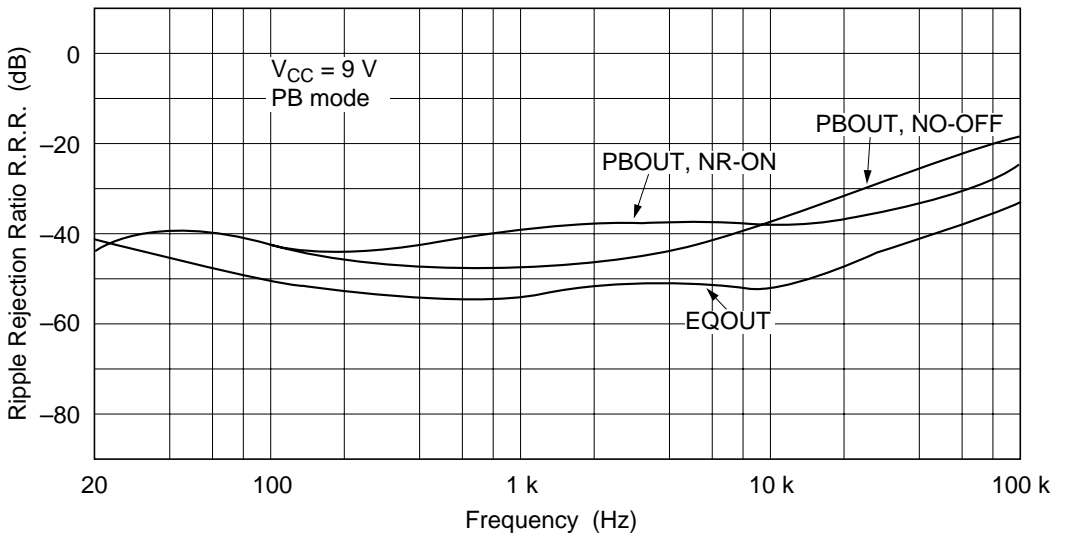

Ripple Rejection Ratio vs. Frequency Characteristics (2)

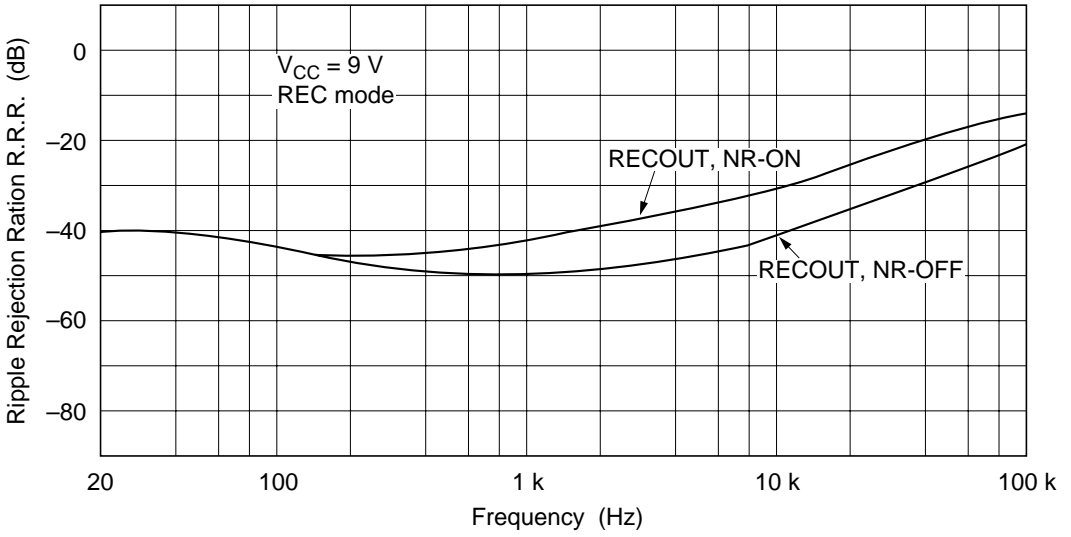

EQ-AMP. Gain vs. Frequency Characteristics

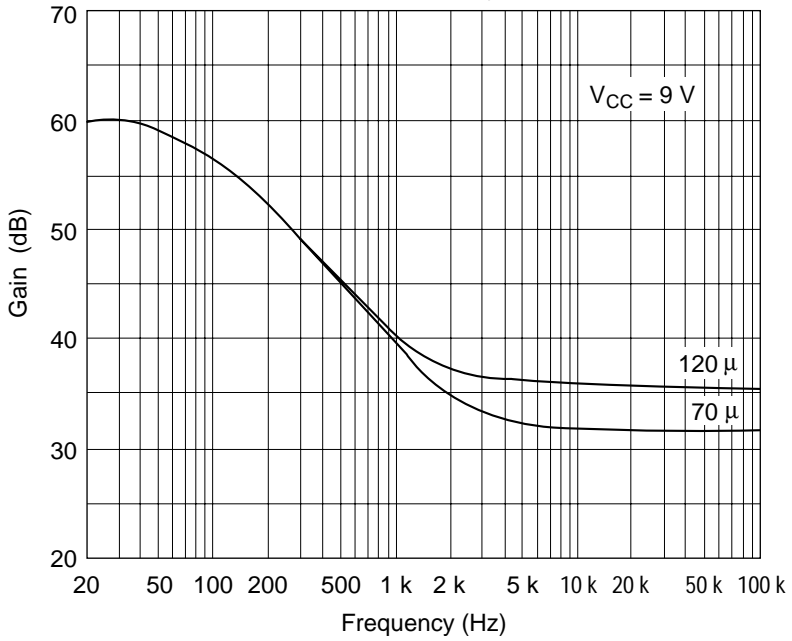

EQout Maximum Output Level vs. Supply Voltage

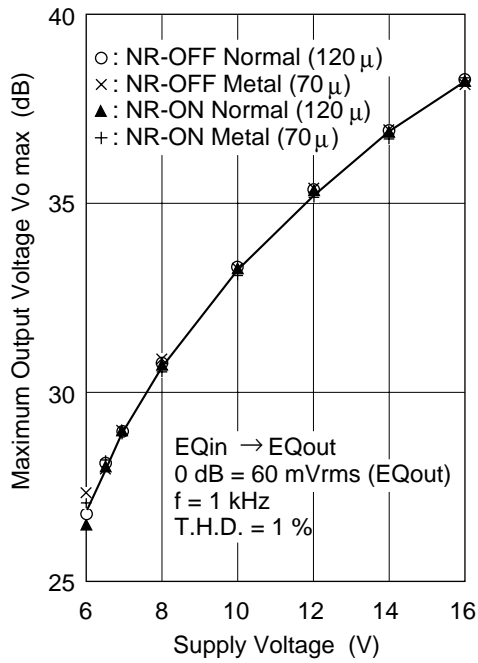

Signal to Noise Ratio vs. Supply Voltage

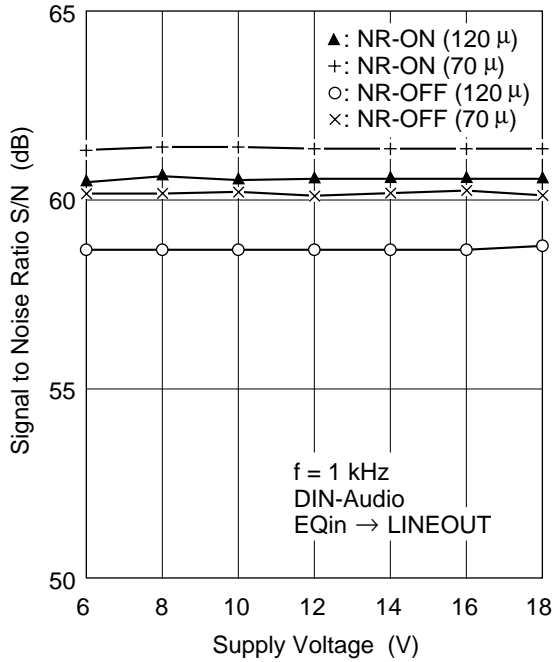

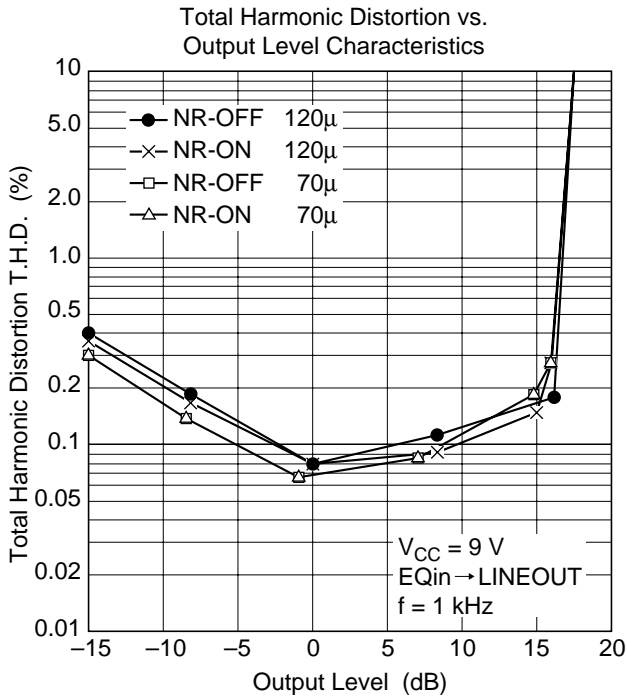
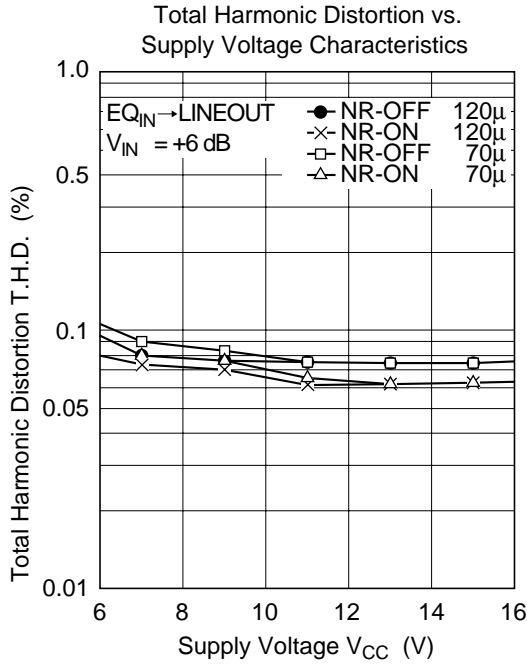

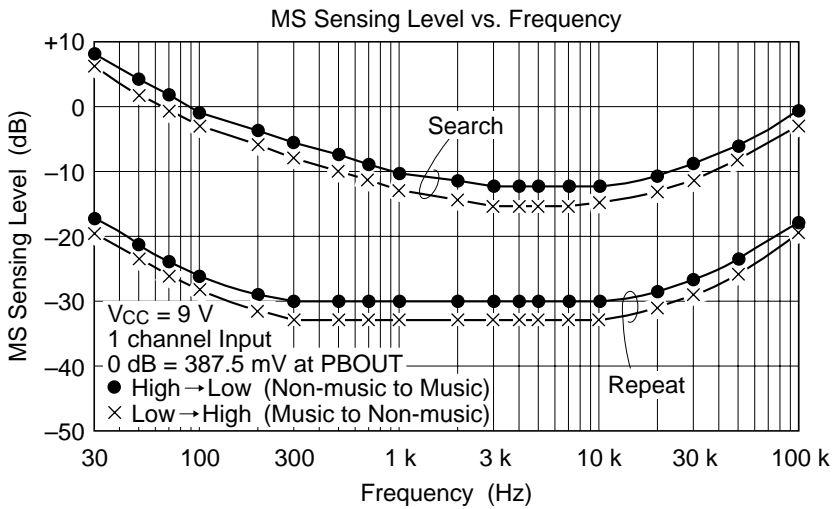
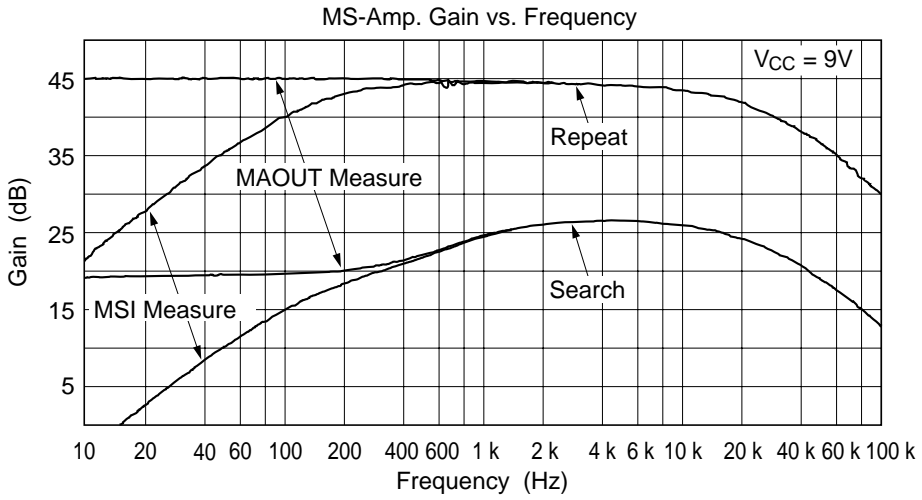

Signal Sensing Time vs. Capacitance
(Music Sensor)

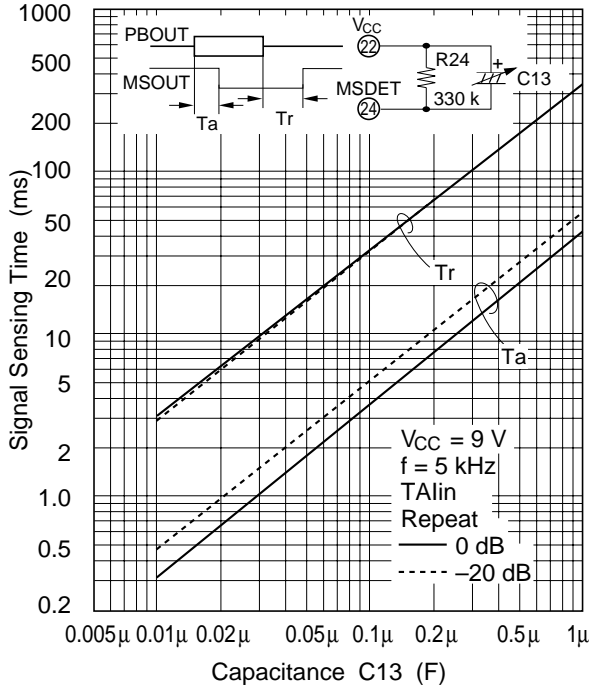

Signal Sensing Time vs. Resistance
(Music Sensor)

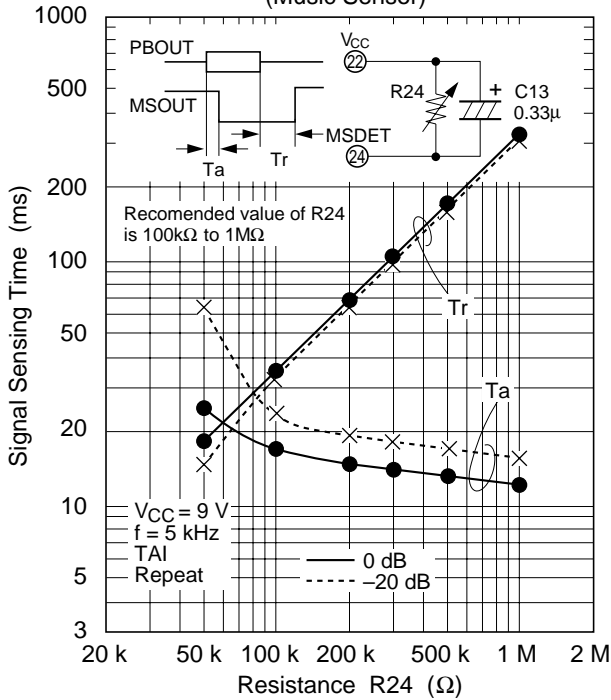

Package Dimensions

Unit: mm

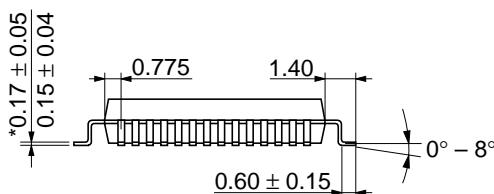
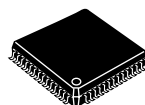
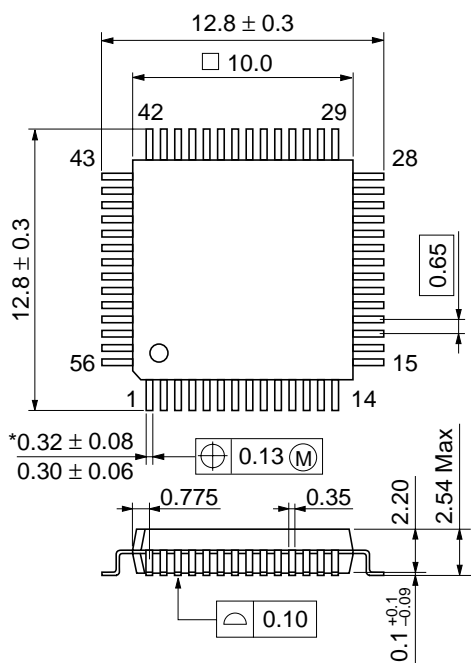

*Dimension including the plating thickness
Base material dimension

Hitachi Code	FP-56
JEDEC	—
EIAJ	—
Weight (reference value)	0.5 g

Cautions

1. Hitachi neither warrants nor grants licenses of any rights of Hitachi's or any third party's patent, copyright, trademark, or other intellectual property rights for information contained in this document. Hitachi bears no responsibility for problems that may arise with third party's rights, including intellectual property rights, in connection with use of the information contained in this document.
2. Products and product specifications may be subject to change without notice. Confirm that you have received the latest product standards or specifications before final design, purchase or use.
3. Hitachi makes every attempt to ensure that its products are of high quality and reliability. However, contact Hitachi's sales office before using the product in an application that demands especially high quality and reliability or where its failure or malfunction may directly threaten human life or cause risk of bodily injury, such as aerospace, aeronautics, nuclear power, combustion control, transportation, traffic, safety equipment or medical equipment for life support.
4. Design your application so that the product is used within the ranges guaranteed by Hitachi particularly for maximum rating, operating supply voltage range, heat radiation characteristics, installation conditions and other characteristics. Hitachi bears no responsibility for failure or damage when used beyond the guaranteed ranges. Even within the guaranteed ranges, consider normally foreseeable failure rates or failure modes in semiconductor devices and employ systemic measures such as fail-safes, so that the equipment incorporating Hitachi product does not cause bodily injury, fire or other consequential damage due to operation of the Hitachi product.
5. This product is not designed to be radiation resistant.
6. No one is permitted to reproduce or duplicate, in any form, the whole or part of this document without written approval from Hitachi.
7. Contact Hitachi's sales office for any questions regarding this document or Hitachi semiconductor products.

HITACHI

Hitachi, Ltd.

Semiconductor & Integrated Circuits.
Nippon Bldg., 2-6-2, Ohte-machi, Chiyoda-ku, Tokyo 100-0004, Japan
Tel: Tokyo (03) 3270-2111 Fax: (03) 3270-5109

URL North America : <http://semiconductor.hitachi.com/>
Europe : <http://www.hitachi-eu.com/hel/ecg>
Asia (Singapore) : <http://www.has.hitachi.com.sg/grp3/sicd/index.htm>
Asia (Taiwan) : http://www.hitachi.com.tw/E/Product/SICD_Frame.htm
Asia (HongKong) : <http://www.hitachi.com.hk/eng/bo/grp3/index.htm>
Japan : <http://www.hitachi.co.jp/Sicd/indx.htm>

For further information write to:

Hitachi Semiconductor
(America) Inc.
179 East Tasman Drive,
San Jose, CA 95134
Tel: <1> (408) 433-1990
Fax: <1>(408) 433-0223

Hitachi Europe GmbH
Electronic components Group
Dornacher Straße 3
D-85622 Feldkirchen, Munich
Germany
Tel: <49> (89) 9 9180-0
Fax: <49> (89) 9 29 30 00

Hitachi Europe Ltd.
Electronic Components Group.
Whitebrook Park
Lower Cookham Road
Maidenhead
Berkshire SL6 8YA, United Kingdom
Tel: <44> (1628) 585000
Fax: <44> (1628) 778322

Hitachi Asia Pte. Ltd.
16 Collyer Quay #20-00
Hitachi Tower
Singapore 049318
Tel: 535-2100
Fax: 535-1533

Hitachi Asia Ltd.
Taipei Branch Office
3F, Hung Kuo Building, No.167,
Tun-Hwa North Road, Taipei (105)
Tel: <886> (2) 2718-3666
Fax: <886> (2) 2718-8180

Hitachi Asia (Hong Kong) Ltd.
Group III (Electronic Components)
7/F., North Tower, World Finance Centre,
Harbour City, Canton Road, Tsim Sha Tsui,
Kowloon, Hong Kong
Tel: <852> (2) 735 9218
Fax: <852> (2) 730 0281
Telex: 40815 HITEC HX

Copyright ' Hitachi, Ltd., 1998. All rights reserved. Printed in Japan.

HITACHI