

---

# HD74CDC2509B

## 3.3-V Phase-lock Loop Clock Driver

# HITACHI

ADE-205-218G (Z)  
8th. Edition  
June 2000

---

### Description

The HD74CDC2509B is a high-performance, low-skew, low-jitter, phase-lock loop clock driver. It uses a phase-lock loop (PLL) to precisely align, in both frequency and phase, the feedback (FBOUT) output to the clock (CLK) input signal. It is specifically designed for use with synchronous DRAMs. The HD74CDC2509B operates at 3.3 V  $V_{CC}$  and is designed to drive up to five clock loads per output.

One bank of five outputs and one bank of four outputs provide nine low-skew, low-jitter copies of the input clock. Output signal duty cycles are adjusted to 50 percent independent of the duty cycle at the input clock. Each bank of outputs can be enabled or disabled separately via the control (1G and 2G) inputs. When the G inputs are high, the outputs switch in phase and frequency with CLK; when the G inputs are low, the outputs are disabled to the logic-low state.

Unlike many products containing PLLs, the HD74CDC2509B does not require external RC networks. The loop filter for the PLL is included on-chip, minimizing component count, board space, and cost.

Because it is based on PLL circuitry, HD74CDC2509B requires a stabilization time to achieve phase lock of the feedback signal to the reference signal. This stabilization time is required, following power up and application of a fixed-frequency, fixed-phase signal at CLK, as well as following any changes to the PLL reference or feedback signals. The PLL can be bypassed for test purposes by strapping  $AV_{CC}$  to ground.

### Features

- Meets “PC SDRAM registered DIMM design support document, Rev. 1.2”
- Phase-lock loop clock distribution for synchronous DRAM applications
- External feedback (FBIN) pin is used to synchronize the outputs to the clock input
- No external RC network required
- Support spread spectrum clock (SSC) synthesizers

Note: Only by a change of a suffix (A to B) for standardization, there isn't any change of the product.

## Function Table

Inputs			Outputs		
1G	2G	CLK	1Y (0:4)	2Y (0:3)	FBOUT
X	X	L	L	L	L
L	L	H	L	L	H
L	H	H	L	H	H
H	L	H	H	L	H
H	H	H	H	H	H

H : High level

L : Low level

X : Immaterial

## Pin Arrangement

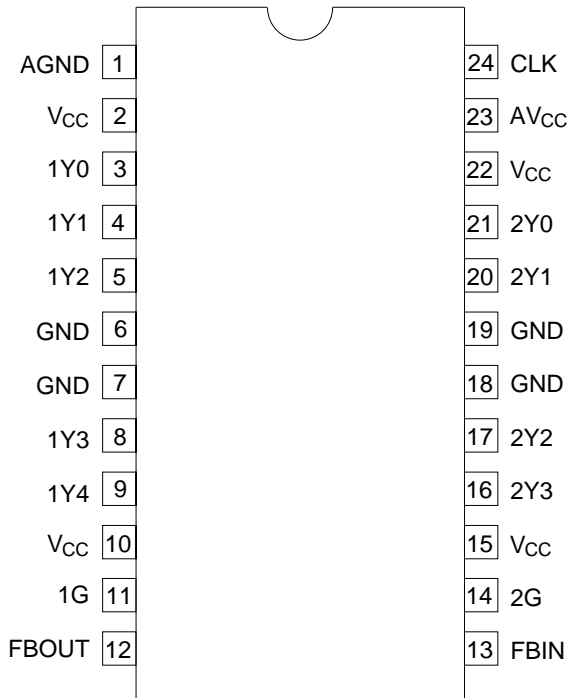

(Top view)

## Absolute Maximum Ratings

Item	Symbol	Ratings	Unit	Conditions
Supply voltage	$V_{CC}$	-0.5 to 4.6	V	
Input voltage <sup>*1</sup>	$V_I$	-0.5 to 6.5	V	
Output voltage <sup>*1,2</sup>	$V_O$	-0.5 to $V_{CC} + 0.5$	V	
Input clamp current	$I_{IK}$	-50	mA	$V_I < 0$
Output clamp current	$I_{OK}$	$\pm 50$	mA	$V_O < 0$ or $V_O > V_{CC}$
Continuous output current	$I_O$	$\pm 50$	mA	$V_O = 0$ to $V_{CC}$
Supply current	$I_{CC}$ or $I_{GND}$	$\pm 100$	mA	
Maximum power dissipation at $T_a = 55^\circ\text{C}$ (in still air) <sup>*3</sup>	$P_T$	0.7	W	
Storage temperature	$T_{stg}$	-65 to +150	$^\circ\text{C}$	

Notes: Stresses beyond those listed under "absolute maximum ratings" may cause permanent damage to the device. These are stress ratings only, and functional operation of the device at these or any other conditions beyond those indicated under "recommended operating conditions" is not implied. Exposure to absolute maximum rated conditions for extended periods may affect device reliability.

1. The input and output negative voltage ratings may be exceeded if the input and output clamp current ratings are observed.
2. This value is limited to 4.6 V maximum.
3. The maximum package power dissipation is calculated using a junction temperature of  $150^\circ\text{C}$  and a board trace length of 750 mils.

## Recommended Operating Conditions

Item	Symbol	Min	Typ	Max	Unit	Conditions
Supply voltage	$V_{CC}$	3.0	—	3.6	V	
Input voltage	$V_{IH}$	2.0	—	—	V	
	$V_{IL}$	—	—	0.8		
	$V_I$	0	—	$V_{CC}$		
Output current	$I_{OH}$	—	—	-12	mA	
	$I_{OL}$	—	—	12		
Operating temperature	$T_a$	0	—	85	$^\circ\text{C}$	

Note: Unused inputs must be held high or low to prevent them from floating.

**Logic Diagram**

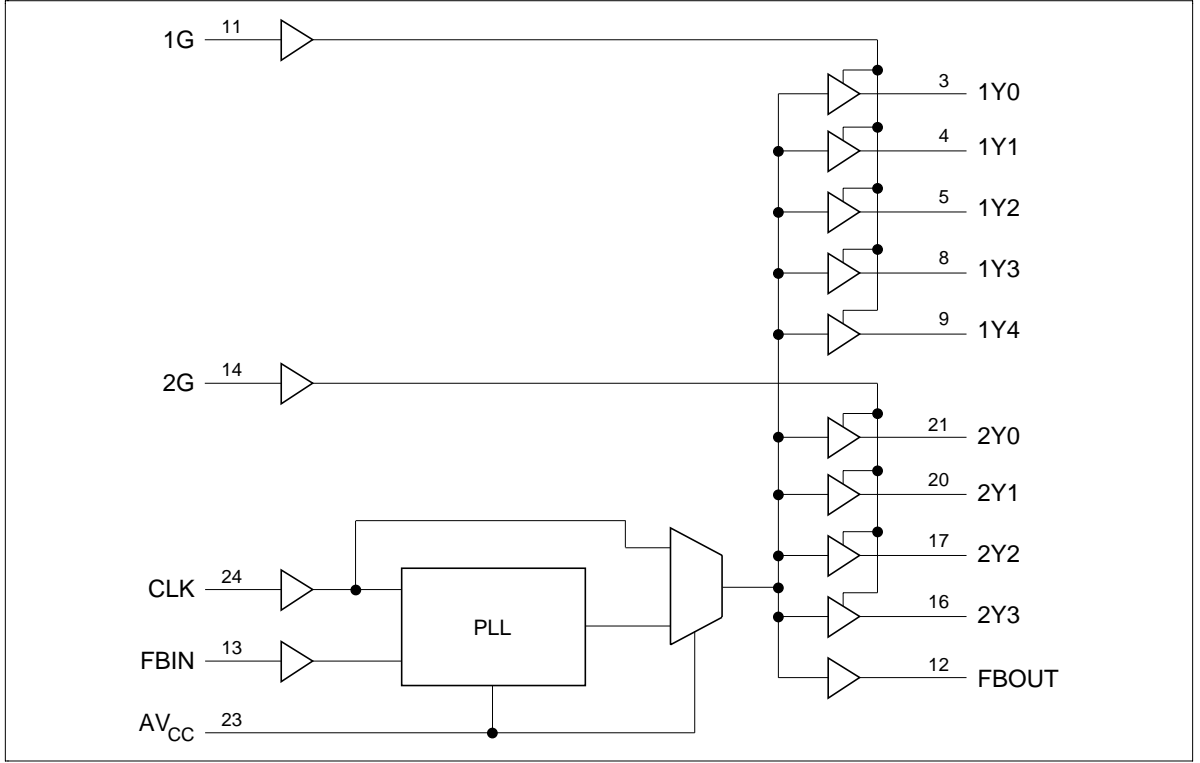

**Pin Function**

Pin name	No.	Type	Description
CLK	24	I	Clock input. CLK provides the clock signal to be distributed by the HD74CDC2509B clock driver. CLK is used to provide the reference signal to the integrated PLL that generates the clock output signals. CLK must have a fixed frequency and fixed phase for the PLL to obtain phase lock. Once the circuit is powered up and a valid CLK signal is applied, a stabilization time is required for the PLL to phase lock the feedback signal to its reference signal.
FBIN	13	I	Feedback input. FBIN provides the feedback signal to the internal PLL. FBIN must be hard-wired to FBOUT to complete the PLL. The integrated PLL synchronizes CLK and FBIN so that there is nominally zero phase error between CLK and FBIN.
1G	11	I	Output bank enable. 1G is the output enable for outputs 1Y(0:4). When 1G is low, outputs 1Y(0:4) are disabled to a logic-low state. When 1G is high, all outputs 1Y(0:4) are enabled and switch at the same frequency as CLK.
2G	14	I	Output bank enable. 2G is the output enable for outputs 2Y(0:3). When 2G is low, outputs 2Y(0:3) are disabled to a logic low state. When 2G is high, all outputs 2Y(0:3) are enabled and switch at the same frequency as CLK.
FBOUT	12	O	Feedback output. FBOUT is dedicated for external feedback. It switches at the same frequency as CLK. When externally wired to FBIN, FBOUT completes the feedback loop of the PLL.
1Y(0:4)	3, 4, 5, 8, 9	O	Clock outputs. These outputs provide low-skew copies of CLK. Output bank 1Y(0:4) is enabled via the 1G input. These outputs can be disabled to a logic low state by deasserting the 1G control input.
2Y(0:3)	16, 17, 20, 21	O	Clock outputs. These outputs provide low-skew copies of CLK. Output bank 2Y(0:3) is enabled via the 2G input. These outputs can be disabled to a logic low state by deasserting the 2G control input.
AV <sub>CC</sub>	23	Power	Analog power supply. AV <sub>CC</sub> provides the power reference for the analog circuitry. In addition, AV <sub>CC</sub> can be used to bypass the PLL for test purposes. When AV <sub>CC</sub> is strapped to ground, PLL is bypassed and CLK is buffered directly to the device outputs.
AGND	1	Ground	Analog ground. AGND provides the ground reference for the analog circuitry.
V <sub>CC</sub>	2, 10, 15, 22	Power	Power supply
GND	6, 7, 18, 19	Ground	Ground

## Electrical Characteristics

Item	Symbol	Min	Typ <sup>*1</sup>	Max	Unit	Test Conditions
Input clamp voltage	$V_{IK}$	—	—	-1.2	V	$V_{CC} = 3\text{ V}$ , $I_I = -18\text{ mA}$
Output voltage	$V_{OH}$	$V_{CC}-0.2$	—	—	V	$V_{CC} = \text{Min to Max}$ , $I_{OH} = -100\text{ }\mu\text{A}$
		2.1	—	—		$V_{CC} = 3\text{ V}$ , $I_{OH} = -12\text{ mA}$
		2.4	—	—		$V_{CC} = 3\text{ V}$ , $I_{OH} = -6\text{ mA}$
	$V_{OL}$	—	—	0.2	V	$V_{CC} = \text{Min to Max}$ , $I_{OL} = 100\text{ }\mu\text{A}$
		—	—	0.8		$V_{CC} = 3\text{ V}$ , $I_{OL} = 12\text{ mA}$
		—	—	0.55		$V_{CC} = 3\text{ V}$ , $I_{OL} = 6\text{ mA}$
Input current	$I_{IN}$	—	—	$\pm 5$	$\mu\text{A}$	$V_{CC} = 3.6\text{ V}$ , $V_{IN} = V_{CC}$ or GND
Quiescent supply current	$I_{CC}$	—	—	10	$\mu\text{A}$	$AV_{CC} = \text{GND}$ , $V_{CC} = 3.6\text{ V}$ , $V_I = V_{CC}$ or GND, $I_O = 0$
	$\Delta I_{CC}$	—	—	500	$\mu\text{A}$	$AV_{CC} = \text{GND}$ , $V_{CC} = 3.3$ to $3.6\text{ V}$ One input at $V_{CC}-0.6\text{ V}$ , Other inputs at $V_{CC}$ or GND
Input capacitance	$C_{IN}$	—	4	—	pF	$V_{CC} = 3.3\text{ V}$ , $V_I = V_{CC}$ or GND
Output capacitance	$C_O$	—	6	—	pF	$V_{CC} = 3.3\text{ V}$ , $V_O = V_{CC}$ or GND

Note: 1. For conditions shown as Min or Max, use the appropriate value specified under recommended operating conditions.

**Switching Characteristics** ( $C_L = 30 \text{ pF}$ ,  $T_a = 0 \text{ to } 85^\circ\text{C}$ )

Item	Symbol	$V_{CC} = 3.3 \text{ V} \pm 0.3 \text{ V}$			Unit	From (Input)	To (Output)
		Min	Typ	Max			
Phase error time	$t_{pe}$	-150	—	150	ps	66 MHz < CLKIN↑ ≤ 100 MHz	FBIN↑
Between output pins skew <sup>*1</sup>	$t_{sk(O)}$	—	—	200	ps	Any Y or FBOUT, F (clkin = 100 MHz)	Any Y or FBOUT
Cycle to cycle jitter		-100	—	100	ps	F (clkin = 100 MHz)	Any Y or FBOUT
Duty cycle		45	—	55	%	F (clkin = 100 MHz)	Any Y or FBOUT
Output rise / fall time	$t_{TLH}$	5.0	—	1.0	volts/ns		Any Y or FBOUT
	$t_{THL}$	5.0	—	1.0			Any Y or FBOUT
Analog power supply rejection (DC to 10 MHz)	$V_{apsr}$ <sup>*2</sup>	100	—	—	$\text{mV}_{P-P}$		$AV_{CC}$

Notes: The specifications for parameters in this table are applicable only after any appropriate stabilization time has elapsed.

1. The  $t_{sk(O)}$  specification is only valid for equal loading of all outputs.
2. This parameter is characterized but not tested.

**Timing requirements**

Item	Symbol	Min	Max	Unit	Test Conditions
Input clock frequency	$f_{clock}$	50	125	MHz	
Input clock duty cycle		40	60	%	
Stabilization time <sup>*1</sup>		—	1	ms	After power up

Note: 1. Time required for the integrated PLL circuit to obtain phase lock of its feedback signal to its reference signal. In order for phase lock to be obtained, a fixed-frequency, fixed-phase reference signal must be present at CLK. Until phase lock is obtained, the specifications for propagation delay and skew parameters given in the switching characteristics table are not applicable.

## Test Circuit

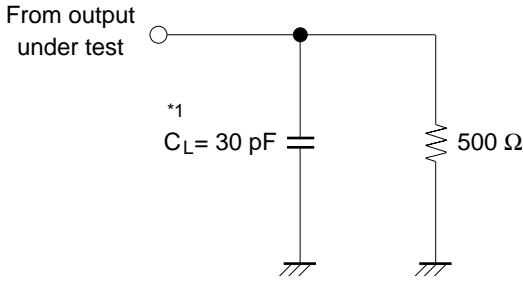

Note: 1.  $C_L$  includes probe and jig capacitance.

## Waveforms – 1

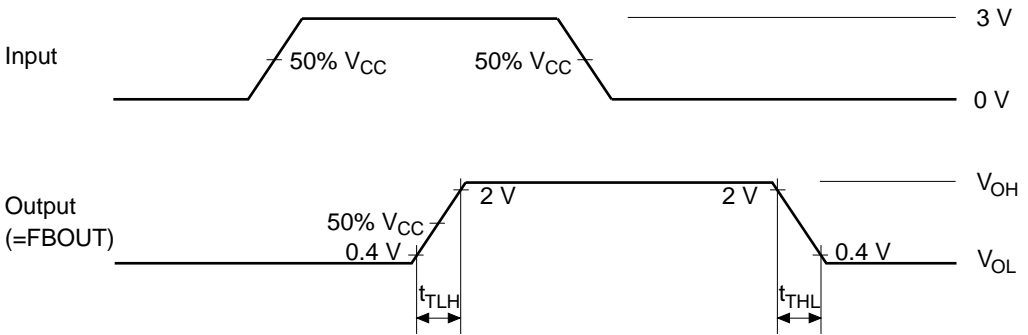

- Notes:
1. All input pulses are supplied by generators having the following characteristics: PRR  $\leq$  100 MHz,  $Z_o = 50 \Omega$ ,  $t_r = 1.2 \text{ ns}$ ,  $t_f = 1.2 \text{ ns}$ .
  2. The outputs are measured one at a time with one transition per measurement.



Waveforms – 2

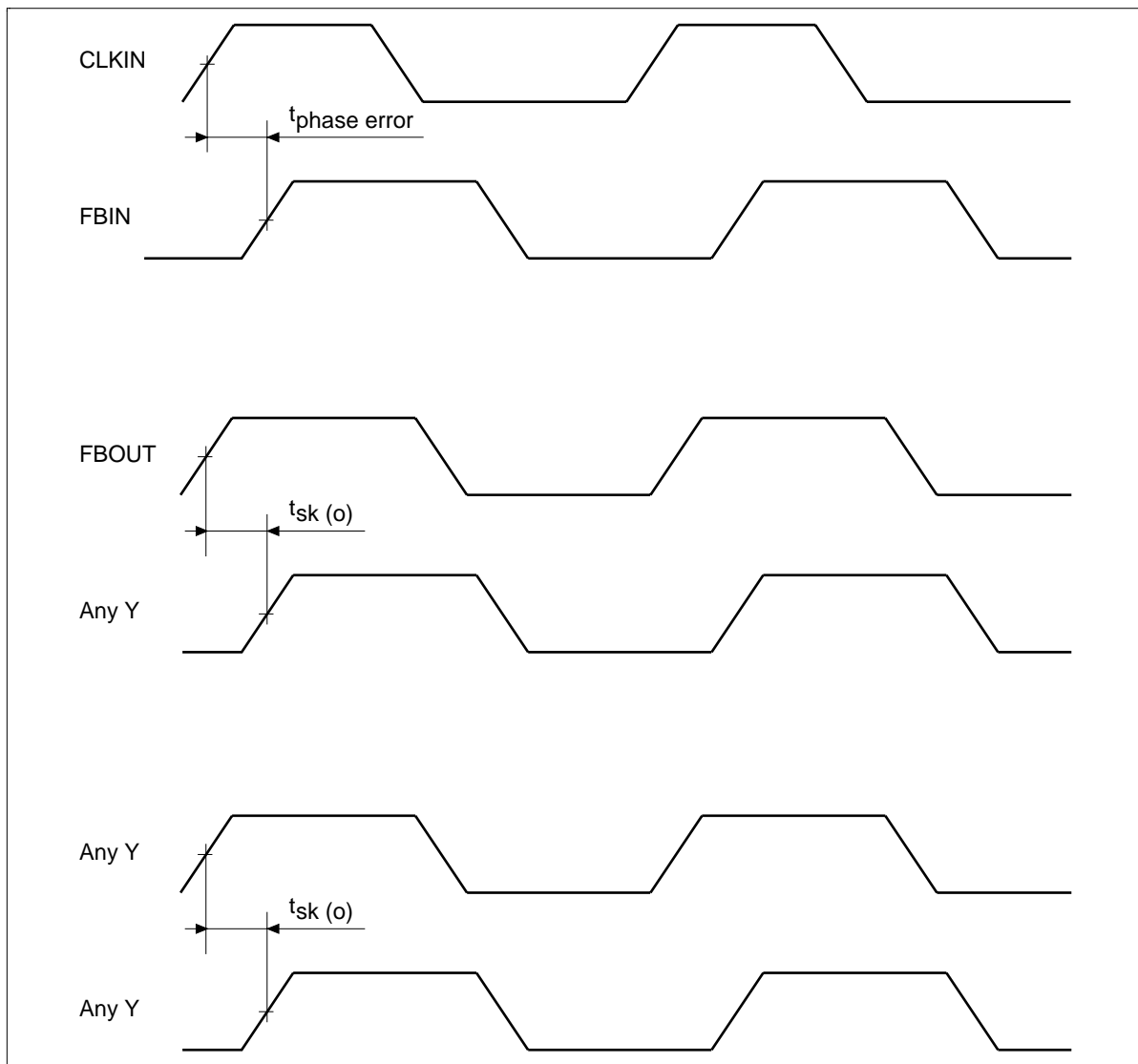

## Package Dimensions

Unit : mm

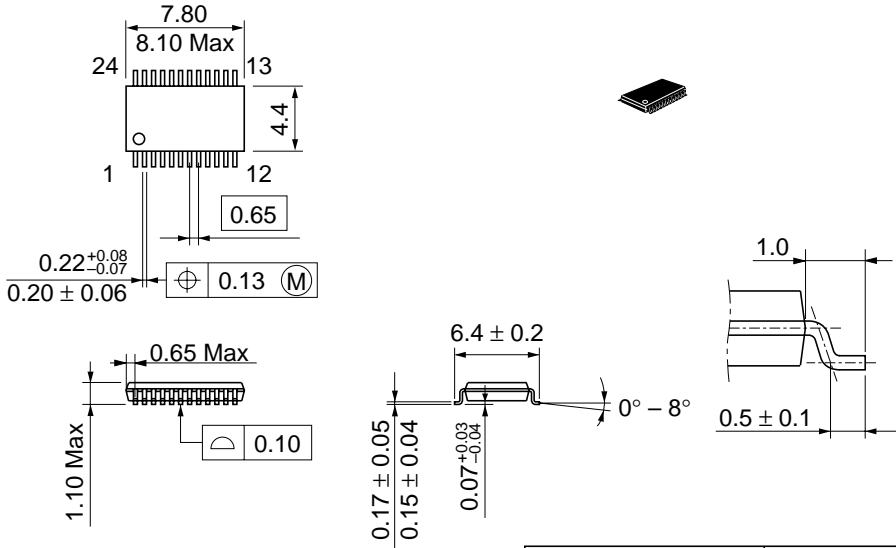

Dimension including the plating thickness  
Base material dimension

Hitachi Code	TTP-24DB
JEDEC	—
EIAJ	—
Weight (reference value)	0.08 g

**Cautions**

1. Hitachi neither warrants nor grants licenses of any rights of Hitachi's or any third party's patent, copyright, trademark, or other intellectual property rights for information contained in this document. Hitachi bears no responsibility for problems that may arise with third party's rights, including intellectual property rights, in connection with use of the information contained in this document.
2. Products and product specifications may be subject to change without notice. Confirm that you have received the latest product standards or specifications before final design, purchase or use.
3. Hitachi makes every attempt to ensure that its products are of high quality and reliability. However, contact Hitachi's sales office before using the product in an application that demands especially high quality and reliability or where its failure or malfunction may directly threaten human life or cause risk of bodily injury, such as aerospace, aeronautics, nuclear power, combustion control, transportation, traffic, safety equipment or medical equipment for life support.
4. Design your application so that the product is used within the ranges guaranteed by Hitachi particularly for maximum rating, operating supply voltage range, heat radiation characteristics, installation conditions and other characteristics. Hitachi bears no responsibility for failure or damage when used beyond the guaranteed ranges. Even within the guaranteed ranges, consider normally foreseeable failure rates or failure modes in semiconductor devices and employ systemic measures such as fail-safes, so that the equipment incorporating Hitachi product does not cause bodily injury, fire or other consequential damage due to operation of the Hitachi product.
5. This product is not designed to be radiation resistant.
6. No one is permitted to reproduce or duplicate, in any form, the whole or part of this document without written approval from Hitachi.
7. Contact Hitachi's sales office for any questions regarding this document or Hitachi semiconductor products.

# HITACHI

**Hitachi, Ltd.**

Semiconductor & Integrated Circuits.  
 Nippon Bldg., 2-6-2, Ohite-machi, Chiyoda-ku, Tokyo 100-0004, Japan  
 Tel: Tokyo (03) 3270-2111 Fax: (03) 3270-5109

URL       NorthAmerica     : <http://semiconductor.hitachi.com/>  
           Europe             : <http://www.hitachi-eu.com/hel/ecg>  
           Asia                : <http://www.hitachi.com.sg/grp3/sicd>  
           Japan               : <http://www.hitachi.co.jp/Sicd/indx.htm>

**For further information write to:**

Hitachi Semiconductor  
 (America) Inc.  
 179 East Tasman Drive,  
 San Jose, CA 95134  
 Tel: <1> (408) 433-1990  
 Fax: <1>(408) 433-0223

Hitachi Europe GmbH  
 Electronic Components Group  
 Dornacher Straße 3  
 D-85622 Feldkirchen, Munich  
 Germany  
 Tel: <49> (89) 9 9180-0  
 Fax: <49> (89) 9 29 30 00

Hitachi Europe Ltd.  
 Electronic Components Group.  
 Whitebrook Park  
 Lower Cookham Road  
 Maidenhead  
 Berkshire SL6 8YA, United Kingdom  
 Tel: <44> (1628) 585000  
 Fax: <44> (1628) 585160

Hitachi Asia Ltd.  
 16 Collyer Quay #20-00  
 Hitachi Tower  
 Singapore 049318  
 Tel: 535-2100  
 Fax: 535-1533

Hitachi Asia Ltd.  
 Taipei Branch Office  
 3rd Flr, Hung Kuo Building, No.167,  
 Tun Hwa North Road, Taipei (105)  
 Taiwan  
 Tel: <886> (2) 2718-3666  
 Fax: <886> (2) 2718-8180  
 Telex: 23222 HAS-TP

Hitachi Asia (Hong Kong) Ltd.  
 Group III (Electronic Components)  
 7th Flr, North Tower, World Finance Centre,  
 Harbour City, Canton Road, Tsim Sha Tsui,  
 Kowloon, Hong Kong  
 Tel: <852> (2) 735 9218  
 Fax: <852> (2) 730 0281  
 Telex: 40815 HITEC HX

Copyright ' Hitachi, Ltd., 2000. All rights reserved. Printed in Japan.  
 Colophon 1.0