

GENERAL DESCRIPTION

The ICS843001-21 is a highly versatile, low phase noise LVPECL Synthesizer which can generate low jitter reference clocks for a variety of communications applications and is a member of the HiPerClocks™ family of high performance clock solutions from ICS. The dual crystal interface allows the synthesizer to support up to two communications standards in a given application (i.e. 1 GB Ethernet with a 25MHz crystal and 1 Gb Fibre Channel using a 25.5625MHz crystal). The rms phase jitter performance is typically less than 1ps, thus making the device acceptable for use in demanding applications such as OC48 SONET and 10 Gb Ethernet. The ICS843001-21 is packaged in a small 24-pin TSSOP package.

FEATURES

- One 3.3V LVPECL output pair and one LVCMOS output
- Selectable crystal oscillator interface or LVCMOS/LVTTL single-ended input
- VCO range: 560MHz - 700MHz
- Supports the following applications: SONET, Ethernet, Fibre Channel, Serial ATA, and HDTV
- RMS phase jitter @ 622.08MHz (12KHz - 20MHz): 0.80ps (typical)
- RMS phase noise at 622.08MHz:

Offset	Noise Power
100Hz	-60.3 dBc/Hz
1KHz	-88.5 dBc/Hz
10KHz	-111.9 dBc/Hz
100KHz	-113.0 dBc/Hz
- Full 3.3V supply mode
- 0°C to 70°C ambient operating temperature
- Lead-Free package RoHS compliant

BLOCK DIAGRAM

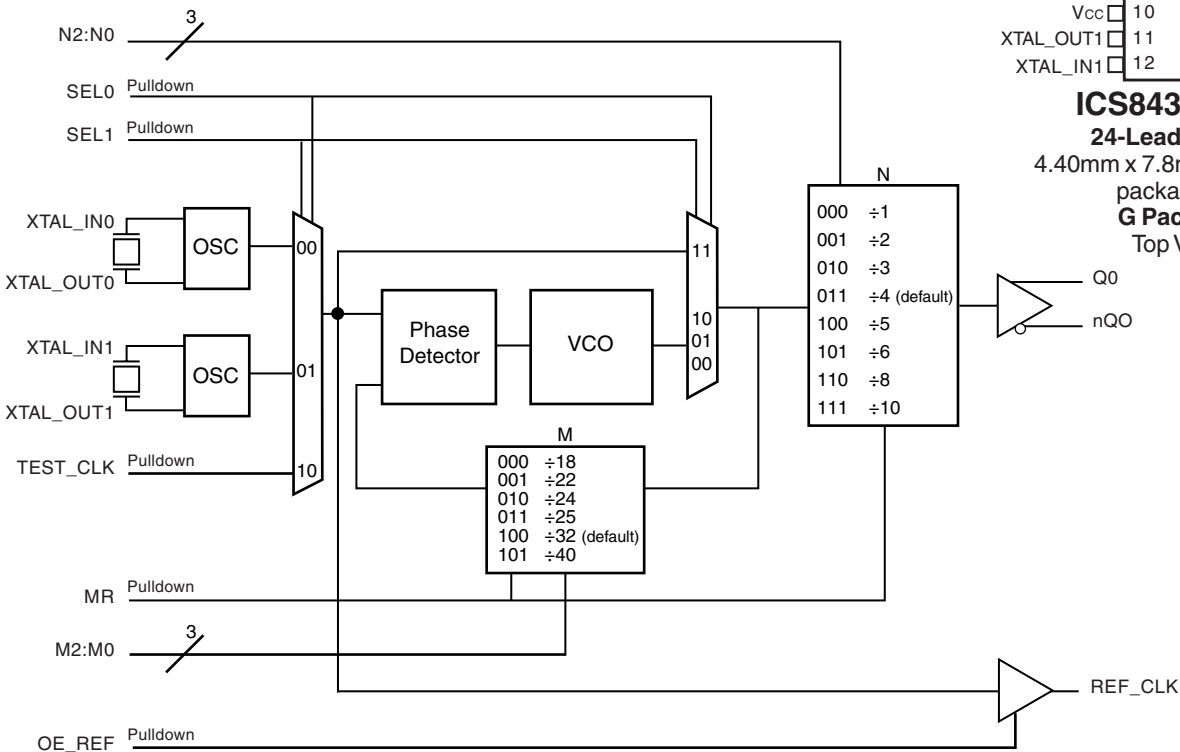

PIN ASSIGNMENT

Vcco_CMOS	1	24	REF_CLK
N0	2	23	VEE
N1	3	22	REF_OE
N2	4	21	M2
Vcco_PECL	5	20	M1
Q0	6	19	M0
nQ0	7	18	MR
VEE	8	17	SEL1
VCCA	9	16	SEL0
Vcc	10	15	TEST_CLK
XTAL_OUT1	11	14	XTAL_IN0
XTAL_IN1	12	13	XTAL_OUT0

ICS843001-21

24-Lead TSSOP
4.40mm x 7.8mm x 0.92mm
package body
G Package
Top View



TABLE 1. PIN DESCRIPTIONS

Number	Name	Type		Description
1	V _{CCO_CMOS}	Power		Output supply pin for LVCMOS output.
2, 3	N0, N1	Input	Pullup	Output divider select pins. Default ÷4. LVCMOS/LVTTL interface levels.
4	N2	Input	Pulldown	
5	V _{CCO_LVPECL}	Power		Output supply pin for LVPECL output.
6, 7	Q0, nQ0	Output		Differential output pair. LVPECL interface levels.
8, 23	V _{EE}	Power		Negative supply pin.
9	V _{CCA}	Power		Analog supply pin.
10	V _{CC}	Power		Core supply pin.
11, 12	XTAL_OUT1, XTAL_IN1	Input		Parallel resonant crystal interface. XTAL_OUT1 is the output, XTAL_IN1 is the input.
13, 14	XTAL_OUT0, XTAL_IN0	Input		Parallel resonant crystal interface. XTAL_OUT0 is the output, XTAL_IN0 is the input.
15	TEST_CLK	Input	Pulldown	LVCMOS/LVTTL clock input.
16, 17	SEL0, SEL1	Input	Pulldown	Input MUX select pins. LVCMOS/LVTTL interface levels.
18	MR	Input	Pulldown	Active HIGH Master Reset. When logic HIGH, the internal dividers are reset causing the true output Q0 to go low and the inverted output nQ0 to go high. When logic LOW, the internal dividers and the outputs are enabled. LVCMOS/LVTTL interface levels.
19, 20	M0, M1	Input	Pulldown	Feedback divider select pins. Default ÷32. LVCMOS/LVTTL interface levels.
21	M2	Input	Pullup	
22	REF_OE	Input	Pulldown	Reference clock output enable. Default Low. LVCMOS/LVTTL interface levels.
24	REF_CLK	Output		Reference clock output. LVCMOS/LVTTL interface levels.

NOTE: *Pullup and Pulldown* refer to internal input resistors. See Table 2, Pin Characteristics, for typical values.

TABLE 2. PIN CHARACTERISTICS

Symbol	Parameter	Test Conditions	Minimum	Typical	Maximum	Units
C _{IN}	Input Capacitance			4		pF
R _{PULLDOWN}	Input Pulldown Resistor			51		KΩ
R _{PULLUP}	Input Pullup Resistor			51		KΩ
R _{OUT}	Output Impedance			7		Ω



TABLE 3A. COMMON CONFIGURATIONS TABLE

Input Reference Clock	M Divider Value	N Divider Value	VCO (MHz)	Output Frequency (MHz)	Application
27	22	8	594	74.25	HDTV
24.75	24	8	594	74.25	HDTV
14.8351649	40	8	593.4066	74.1758245	HDTV
19.44	32	4	622.08	155.52	SONET
19.44	32	8	622.08	77.76	SONET
19.44	32	1	622.08	622.08	SONET
19.44	32	2	622.08	311.04	SONET
19.53125	32	4	625	156.25	10 GigE
25	25	5	625	125	1 GigE
25	25	10	625	62.5	1 GigE
25	24	6	600	100	PCI Express
25	24	4	600	150	SATA
25	24	8	600	75	SATA
26.5625	24	6	637.5	106.25	Fibre Channel 1
26.5625	24	3	637.5	212.5	4 Gig Fibre Channel
26.5625	24	4	637.5	159.375	10 Gig Fibre Channel
31.25	18	3	562.5	187.5	12 Gig Ethernet

**TABLE 3B. PROGRAMMABLE M OUTPUT DIVIDER
FUNCTION TABLE**

Inputs			M Divider Value	Input Frequency	
M2	M1	M0		Minimum	Maximum
0	0	0	18	31.1	38.9
0	0	1	22	25.5	31.8
0	1	0	24	23.3	29.2
0	1	1	25	22.4	28.0
1	0	0	32	17.5	21.9
1	0	1	40	14.0	17.5

**TABLE 3C. PROGRAMMABLE N OUTPUT DIVIDER
FUNCTION TABLE**

Inputs			M Divide Value
N2	N1	N0	
0	0	0	1
0	0	1	2
0	1	0	3
0	1	1	4
1	0	0	5
1	0	1	6
1	1	0	8
1	1	1	10

TABLE 3D. BYPASS MODE FUNCTION TABLE

Inputs		Reference	PLL Mode
SEL1	SEL0		
0	0	XTAL0	Active
0	1	XTAL1	Active
1	0	TEST_CLK	Active
1	1	TEST_CLK	Bypass



ABSOLUTE MAXIMUM RATINGS

Supply Voltage, V_{CC}	4.6V
Inputs, V_i	-0.5V to $V_{CC} + 0.5V$
Outputs, I_o (LVPECL)	
Continuous Current	50mA
Surge Current	100mA
Outputs, V_o (LVCMOS)	-0.5V to $V_{CCO} + 0.5V$
Package Thermal Impedance, θ_{JA}	70°C/W (0 mps)
Storage Temperature, T_{STG}	-65°C to 150°C

NOTE: Stresses beyond those listed under Absolute Maximum Ratings may cause permanent damage to the device. These ratings are stress specifications only. Functional operation of product at these conditions or any conditions beyond those listed in the *DC Characteristics* or *AC Characteristics* is not implied. Exposure to absolute maximum rating conditions for extended periods may affect product reliability.

TABLE 4A. POWER SUPPLY DC CHARACTERISTICS, $V_{CC} = V_{CCA} = V_{CCO} = 3.3V \pm 5\%$, $T_A = 0^\circ C$ TO $70^\circ C$

Symbol	Parameter	Test Conditions	Minimum	Typical	Maximum	Units
V_{CC}	Core Supply Voltage		3.135	3.3	3.465	V
V_{CCA}	Analog Supply Voltage		3.135	3.3	3.465	V
$V_{CCO_PECL_CMOS}$	Output Supply Voltage		3.135	3.3	3.465	V
I_{EE}	Power Supply Current				170	mA
I_{CCA}	Analog Supply Current				11	mA
$I_{CCO_PECL_CMOS}$	Output Supply Current				8	mA

TABLE 4B. LVCMOS / LVTTTL DC CHARACTERISTICS, $V_{CC} = V_{CCA} = V_{CCO} = 3.3V \pm 5\%$, $T_A = 0^\circ C$ TO $70^\circ C$

Symbol	Parameter	Test Conditions	Minimum	Typical	Maximum	Units
V_{IH}	Input High Voltage		2		$V_{CC} + 0.3$	V
V_{IL}	Input Low Voltage	SEL0, SEL1, OE_REF, MR, M0:M2, N0:N2	-0.3		0.8	V
		TEST_CLK	-0.3		1.3	V
I_{IH}	Input High Current	TEST_CLK, SEL0, SEL1, OE_REF, MR, M0, M1, N2	$V_{CC} = V_{IN} = 3.465V$		150	μA
		M2, N0, N1	$V_{CC} = V_{IN} = 3.465V$		5	μA
I_{IL}	Input Low Current	TEST_CLK, SEL0, SEL1, OE_REF, MR, M0, M1, N2	$V_{CC} = 3.465V, V_{IN} = 0V$	-5		μA
		M2, N0, N1	$V_{CC} = 3.465V, V_{IN} = 0V$	-150		μA
V_{OH}	Output High Voltage; NOTE 1	REF_CLK	2.6			V
V_{OL}	Output Low Voltage: Note 1	REF_CLK			0.5	V

NOTE 1: Output terminated with 50 Ω to $V_{CCO_CMOS}/2$. See Parameter Measurement Information Section, "3.3V Output Load Test Circuit Diagram".



TABLE 4C. LVPECL DC CHARACTERISTICS, $V_{CC} = V_{CCA} = V_{CCO} = 3.3V \pm 5\%$, $T_A = 0^\circ C$ TO $70^\circ C$

Symbol	Parameter	Test Conditions	Minimum	Typical	Maximum	Units
V_{OH}	Output High Voltage; NOTE 1		$V_{CCO} - 1.4$		$V_{CCO} - 0.9$	V
V_{OL}	Output Low Voltage; NOTE 1		$V_{CCO} - 2.0$		$V_{CCO} - 1.7$	V
V_{SWING}	Peak-to-Peak Output Voltage Swing		0.6		1.0	V

NOTE 1: Outputs terminated with 50Ω to $V_{CCO_PECL} - 2V$.

TABLE 5. CRYSTAL CHARACTERISTICS

Parameter	Test Conditions	Minimum	Typical	Maximum	Units
Mode of Oscillation		Fundamental			MHz
Frequency		12		40	MHz
Equivalent Series Resistance (ESR)				50	Ω
Shunt Capacitance				7	pF

NOTE: Characterized using an 18pF parallel resonant crystal.

TABLE 6. AC CHARACTERISTICS, $V_{CC} = V_{CCA} = V_{CCO} = 3.3V \pm 5\%$, $T_A = 0^\circ C$ TO $70^\circ C$

Symbol	Parameter	Test Conditions	Minimum	Typical	Maximum	Units
f_{OUT}	Output Frequency		56		700	MHz
t_{PD}	Propagation Delay, NOTE 1	TEST_CLK to REF_CLK	2.3		2.8	ns
$f_{jit}(\emptyset)$	RMS Phase Jitter, (Random); NOTE 2, 3	622.08MHz (12KHz - 20MHz)		0.80		ps
f_{VCO}	PLL VCO Lock Range		560		700	MHz
t_R / t_F	Output Rise/Fall Time	LVPECL	20% to 80%	200	500	ps
		LVC MOS	20% to 80%	300	800	ps
odc	Output Duty Cycle	LVPECL		45	55	%
		LVC MOS		44	56	%

NOTE 1: Measured from the $V_{CC}/2$ of the input to $V_{CCO_CMOS}/2$ of the output.

NOTE 2: Phase jitter measured using a 19.44MHz quartz crystal.

NOTE 3: This parameter is defined in accordance with JEDEC Standard 65.

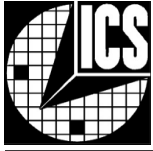

TYPICAL PHASE NOISE AT 622.08MHz

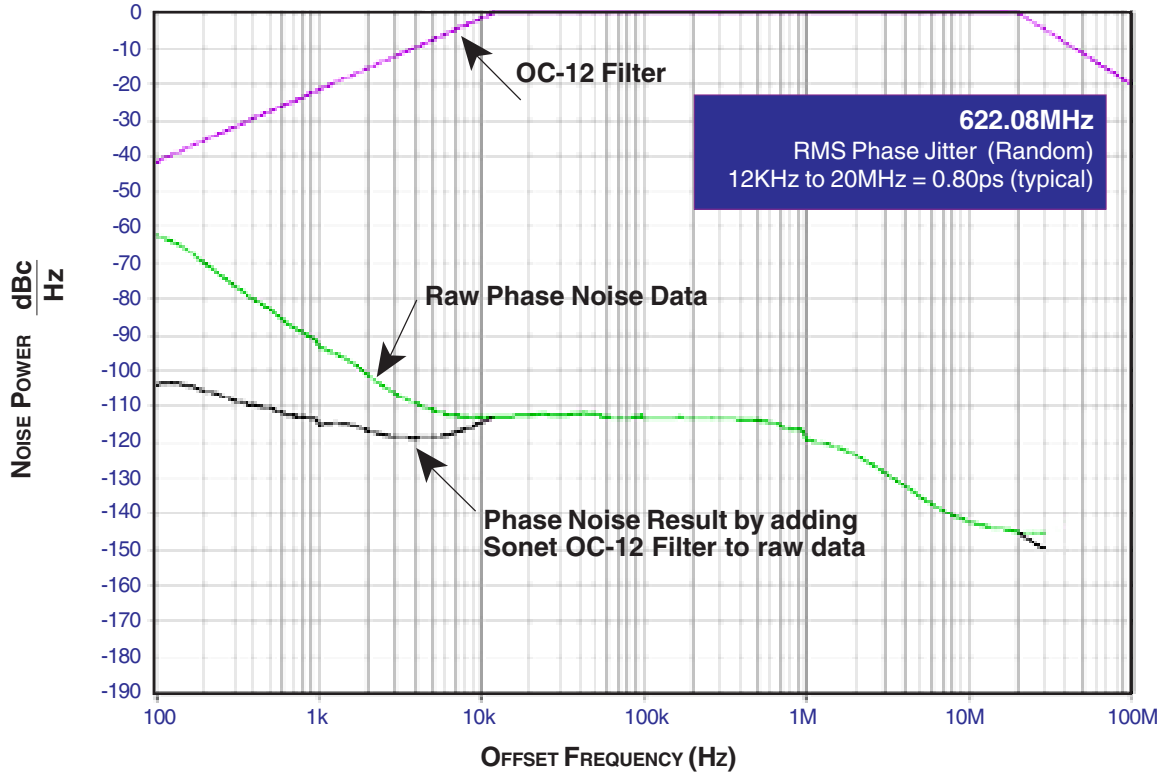



PARAMETER MEASUREMENT INFORMATION

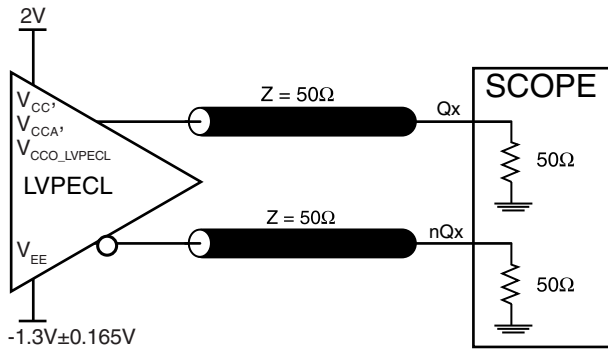

3.3V LVPECL OUTPUT LOAD AC TEST CIRCUIT

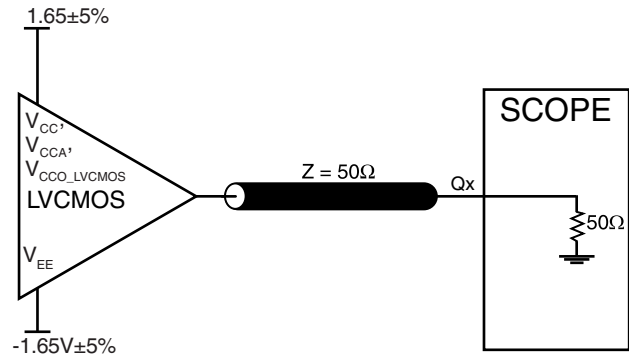

3.3V LVCMOS OUTPUT LOAD AC TEST CIRCUIT

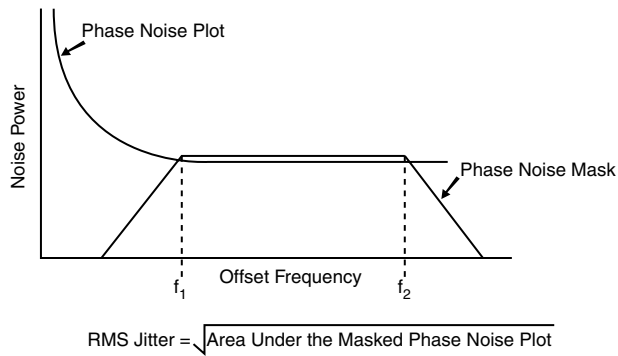

RMS PHASE JITTER

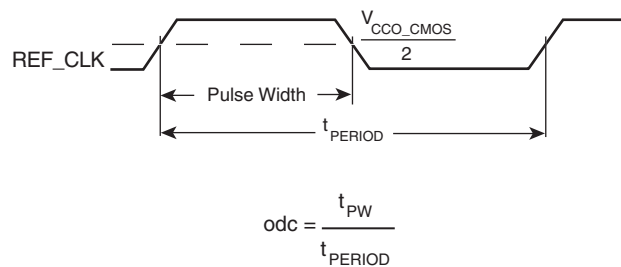
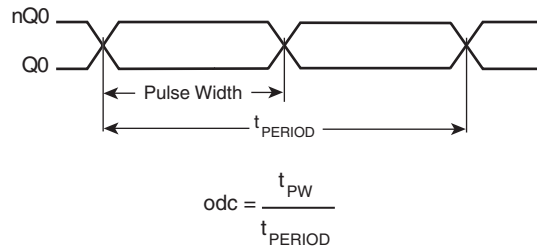

OUTPUT DUTY CYCLE/PULSE WIDTH/PERIOD

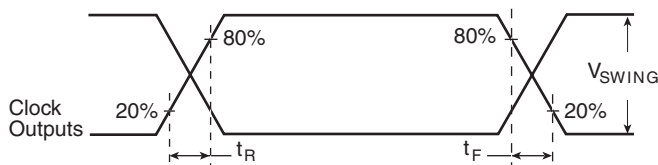

OUTPUT RISE/FALL TIME

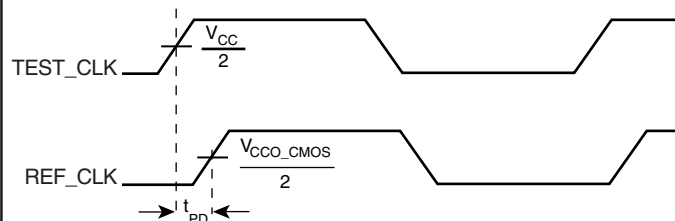

PROPAGATION DELAY



APPLICATION INFORMATION

POWER SUPPLY FILTERING TECHNIQUES

As in any high speed analog circuitry, the power supply pins are vulnerable to random noise. The ICS843001-21 provides separate power supplies to isolate any high switching noise from the outputs to the internal PLL. V_{CC} , V_{CCA} , and V_{CCO_x} should be individually connected to the power supply plane through vias, and bypass capacitors should be used for each pin. To achieve optimum jitter performance, power supply isolation is required. *Figure 1* illustrates how a 10Ω resistor along with a $10\mu\text{F}$ and a $.01\mu\text{F}$ bypass capacitor should be connected to each V_{CCA} .

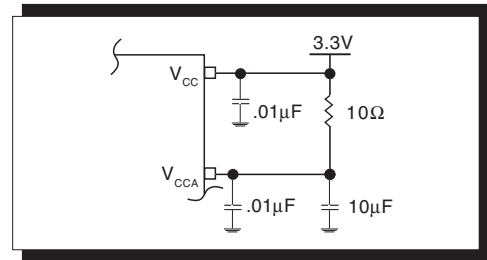

FIGURE 1. POWER SUPPLY FILTERING

TERMINATION FOR 3.3V LVPECL OUTPUT

The clock layout topology shown below is a typical termination for LVPECL outputs. The two different layouts mentioned are recommended only as guidelines.

FOUT and nFOUT are low impedance follower outputs that generate ECL/LVPECL compatible outputs. Therefore, terminating resistors (DC current path to ground) or current sources must be used for functionality. These outputs are

designed to drive 50Ω transmission lines. Matched impedance techniques should be used to maximize operating frequency and minimize signal distortion. *Figures 2A and 2B* show two different layouts which are recommended only as guidelines. Other suitable clock layouts may exist and it would be recommended that the board designers simulate to guarantee compatibility across all printed circuit and clock component process variations.

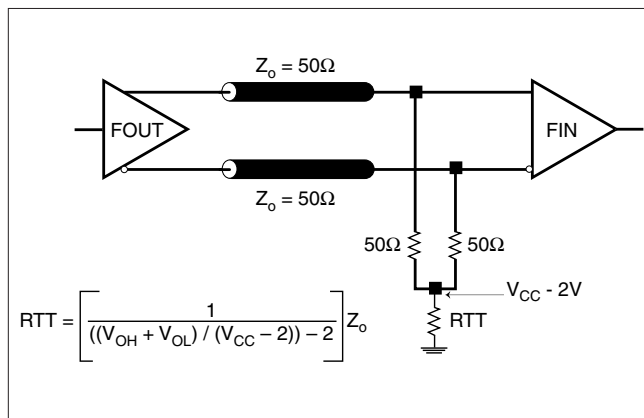

FIGURE 2A. LVPECL OUTPUT TERMINATION

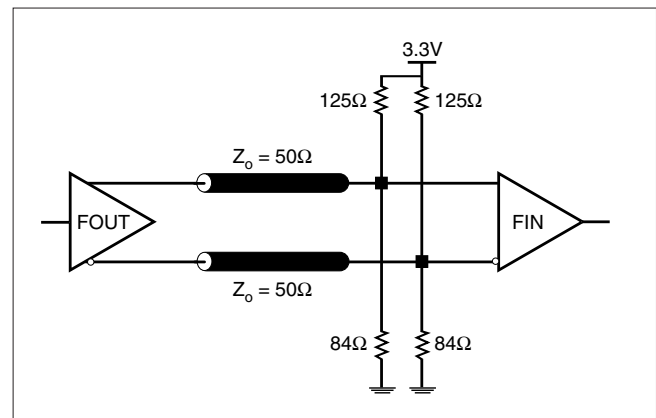

FIGURE 2B. LVPECL OUTPUT TERMINATION



CRYSTAL INPUT INTERFACE

The ICS843001-21 has been characterized with 18pF parallel resonant crystals. The capacitor values shown in *Figure 3* below were determined using a 19.44MHz 18pF parallel resonant crystal and were chosen to minimize the ppm error.

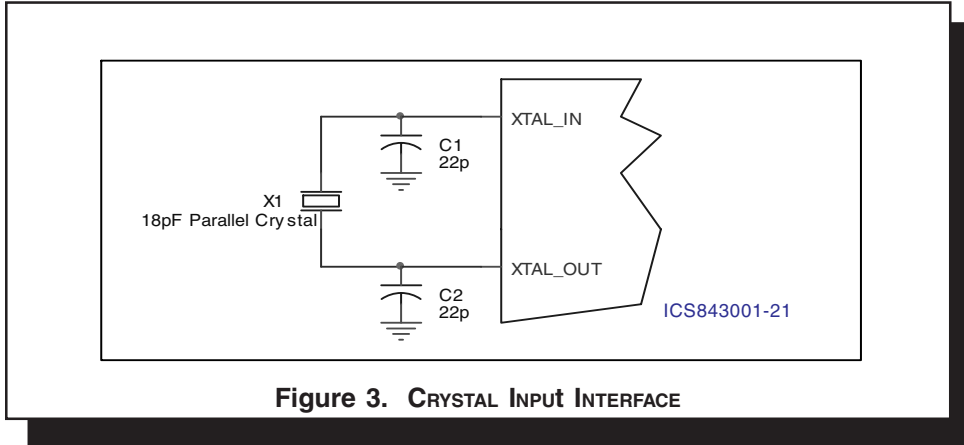

Figure 3. CRYSTAL INPUT INTERFACE



POWER CONSIDERATIONS

This section provides information on power dissipation and junction temperature for the ICS843001-21. Equations and example calculations are also provided.

1. Power Dissipation.

The total power dissipation for the ICS843001-21 is the sum of the core power plus the power dissipated in the load(s). The following is the power dissipation for $V_{CC} = 3.3V + 5\% = 3.465V$, which gives worst case results.

NOTE: Please refer to Section 3 for details on calculating power dissipated in the load.

- Power (core)_{MAX} = $V_{CC_MAX} * I_{EE_MAX} = 3.465V * 170mA = 589.05mW$
- Power (outputs)_{MAX} = **30mW/Loaded Output pair**

$$\text{Total Power}_{MAX} (3.465V, \text{ with all outputs switching}) = 589.05mW + 30mW = \mathbf{619.05mW}$$

2. Junction Temperature.

Junction temperature, T_j , is the temperature at the junction of the bond wire and bond pad and directly affects the reliability of the device. The maximum recommended junction temperature for HiPerClockS™ devices is 125°C.

The equation for T_j is as follows: $T_j = \theta_{JA} * Pd_total + T_A$

T_j = Junction Temperature

θ_{JA} = Junction-to-Ambient Thermal Resistance

Pd_total = Total Device Power Dissipation (example calculation is in section 1 above)

T_A = Ambient Temperature

In order to calculate junction temperature, the appropriate junction-to-ambient thermal resistance θ_{JA} must be used. Assuming a moderate air flow of 1 meter per second and a multi-layer board, the appropriate value is 65°C/W per Table 7 below.

Therefore, T_j for an ambient temperature of 70°C with all outputs switching is:
 $70^\circ C + 0.619W * 65^\circ C/W = 110.2^\circ C$. This is below the limit of 125°C.

This calculation is only an example. T_j will obviously vary depending on the number of loaded outputs, supply voltage, air flow, and the type of board (single layer or multi-layer).

TABLE 7. THERMAL RESISTANCE θ_{JA} FOR 24-PIN TSSOP, FORCED CONVECTION

θ_{JA} by Velocity (Meters per Second)			
	0	1	2.5
Multi-Layer PCB, JEDEC Standard Test Boards	70°C/W	65°C/W	62°C/W



3. Calculations and Equations.

The purpose of this section is to derive the power dissipated into the load.

LVPECL output driver circuit and termination are shown in *Figure 4*.

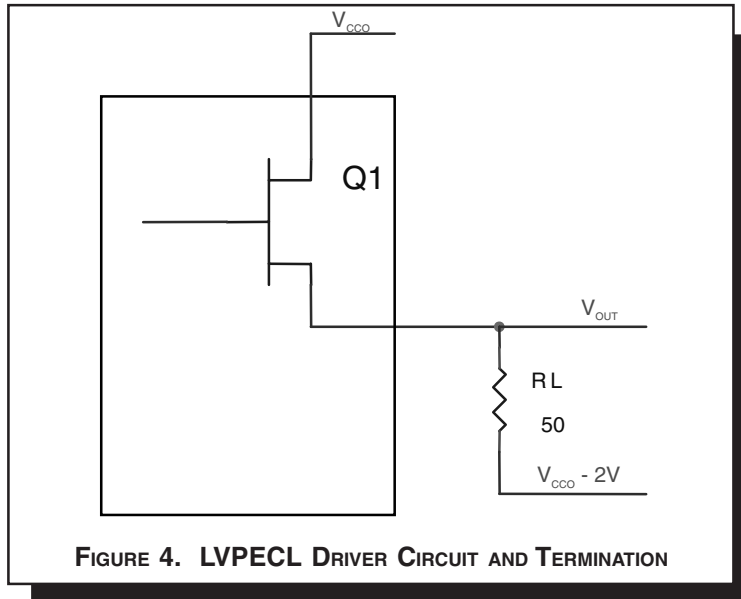

FIGURE 4. LVPECL DRIVER CIRCUIT AND TERMINATION

To calculate worst case power dissipation into the load, use the following equations which assume a 50Ω load, and a termination voltage of $V_{CC} - 2V$.

- For logic high, $V_{OUT} = V_{OH_MAX} = V_{CC_MAX} - 0.9V$

$$(V_{CC_MAX} - V_{OH_MAX}) = 0.9V$$

- For logic low, $V_{OUT} = V_{OL_MAX} = V_{CC_MAX} - 1.7V$

$$(V_{CC_MAX} - V_{OL_MAX}) = 1.7V$$

Pd_H is power dissipation when the output drives high.

Pd_L is the power dissipation when the output drives low.

$$Pd_H = [(V_{OH_MAX} - (V_{CC_MAX} - 2V))/R_L] * (V_{CC_MAX} - V_{OH_MAX}) = [(2V - (V_{CC_MAX} - V_{OH_MAX}))/R_L] * (V_{CC_MAX} - V_{OH_MAX}) = [(2V - 0.9V)/50\Omega] * 0.9V = 19.8mW$$

$$Pd_L = [(V_{OL_MAX} - (V_{CC_MAX} - 2V))/R_L] * (V_{CC_MAX} - V_{OL_MAX}) = [(2V - (V_{CC_MAX} - V_{OL_MAX}))/R_L] * (V_{CC_MAX} - V_{OL_MAX}) = [(2V - 1.7V)/50\Omega] * 1.7V = 10.2mW$$

Total Power Dissipation per output pair = $Pd_H + Pd_L = 30mW$



RELIABILITY INFORMATION

TABLE 8. θ_{JA} VS. AIR FLOW TABLE FOR 24 LEAD TSSOP

θ_{JA} by Velocity (Meters per Second)			
	0	1	2.5
Multi-Layer PCB, JEDEC Standard Test Boards	70°C/W	65°C/W	62°C/W

TRANSISTOR COUNT

The transistor count for ICS843001-21 is: 4057



PACKAGE OUTLINE - G SUFFIX FOR 24 LEAD TSSOP

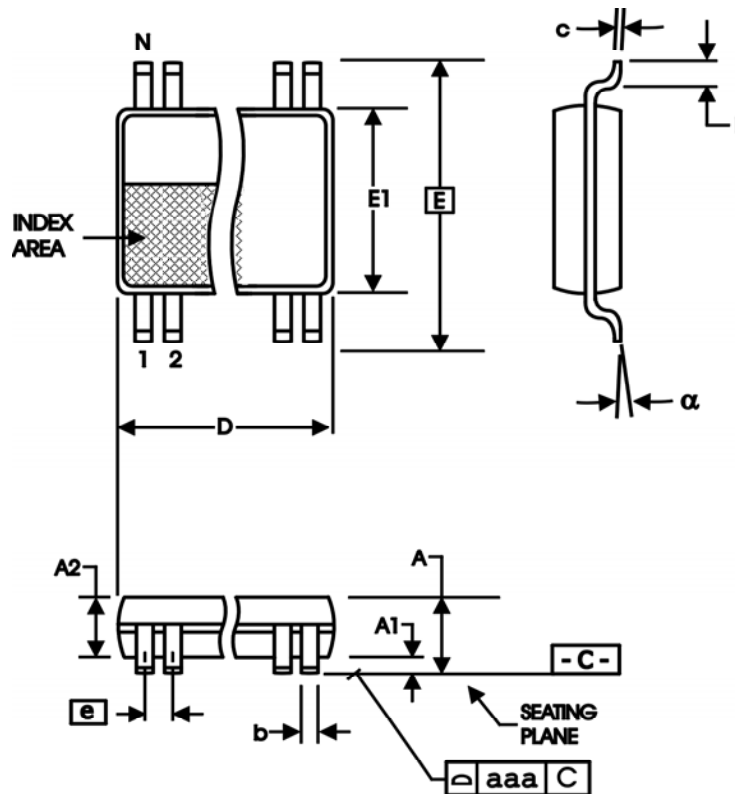
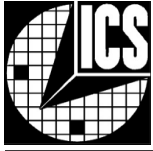

TABLE 9. PACKAGE DIMENSIONS

SYMBOL	Millimeters	
	Minimum	Maximum
N	24	
A	--	1.20
A1	0.05	0.15
A2	0.80	1.05
b	0.19	0.30
c	0.09	0.20
D	7.70	7.90
E	6.40 BASIC	
E1	4.30	4.50
e	0.65 BASIC	
L	0.45	0.75
alpha	0°	8°
aaa	--	0.10

Reference Document: JEDEC Publication 95, MO-153



Integrated
Circuit
Systems, Inc.

ICS843001-21

FEMTOCLOCKS™ CRYSTAL-TO-3.3V LVPECL FREQUENCY SYNTHESIZER

TABLE 10. ORDERING INFORMATION

Part/Order Number	Marking	Package	Shipping Packaging	Temperature
ICS843001AG-21	ICS843001A21	24 Lead TSSOP	tube	0°C to 70°C
ICS843001AG-21T	ICS843001A21	24 Lead TSSOP	2500 tape & reel	0°C to 70°C
ICS843001AG-21LF	ICS843001A21L	24 Lead "Lead-Free" TSSOP	tube	0°C to 70°C
ICS843001AG-21LFT	ICS843001A21L	24 Lead "Lead-Free" TSSOP	2500 tape & reel	0°C to 70°C

The aforementioned trademarks, HiPerClockS™ and FemtoClocks™ are a trademark of Integrated Circuit Systems, Inc. or its subsidiaries in the United States and/or other countries. While the information presented herein has been checked for both accuracy and reliability, Integrated Circuit Systems, Incorporated (ICS) assumes no responsibility for either its use or for infringement of any patents or other rights of third parties, which would result from its use. No other circuits, patents, or licenses are implied. This product is intended for use in normal commercial applications. Any other applications such as those requiring extended temperature range, high reliability, or other extraordinary environmental requirements are not recommended without additional processing by ICS. ICS reserves the right to change any circuitry or specifications without notice. ICS does not authorize or warrant any ICS product for use in life support devices or critical medical instruments.



Integrated
Circuit
Systems, Inc.

ICS843001-21
FEMTOCLOCKS™ CRYSTAL-TO-3.3V LVPECL
FREQUENCY SYNTHESIZER

REVISION HISTORY SHEET

Rev	Table	Page	Description of Change	Date
A	T10	1 14	Features Section - added Lead-Free bullet. Ordering Information table - added Lead-Free marking.	2/8/05