

**Dual SPDT CMOS Analog Switch**

The HI-303/883 switch is a monolithic device fabricated using CMOS technology and the Intersil Dielectric Isolation process. This switch features break-before-make switching, low and nearly constant ON resistance over the full analog signal range, and low power dissipation.

The HI-303/883 is TTL compatible and has a logic “0” condition with an input less than 0.8V and a logic “1” condition with an input greater than 4.0V.

The HI-303/883 is pin-for-pin compatible with the industry standard Siliconix DG303. The device is available in a 14 pin Ceramic DIP. The HI-303/883 operates over the -55°C to +125°C temperature range.

**Pinout**

**HI1-303/883 (CERAMIC DIP)  
TOP VIEW**

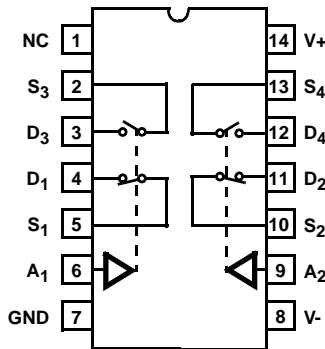

| LOGIC | SW1<br>SW2 | SW3<br>SW4 |
|-------|------------|------------|
| 0     | Off        | On         |
| 1     | On         | Off        |

**Features**

- This Circuit is Processed in Accordance to MIL-STD-883 and is Fully Conformant Under the Provisions of Paragraph 1.2.1.
- Analog Signal Range ( $\pm 15V$  Supplies) . . . . .  $\pm 15V$
- Low Leakage (+25°C) . . . . . 1nA (Max)
- Low Leakage (+125°C) . . . . . 100nA (Max)
- Low ON Resistance . . . . . 50 $\Omega$  (Max)
- Charge Injection . . . . . 30pC (Typ)
- TTL Compatible
- System Switch Elements
- Low Operating Power
- Compatible with DG303

**Applications**

- Sample and Hold, i.e. Low Leakage Switching
- Op Amp Gain Switching, i.e. Low ON Resistance
- Portable, Battery Operated Circuits
- Low Level Switching Circuits
- Dual or Single Supply Systems

**Absolute Maximum Ratings**

Voltage Between V+ and V- Terminals ..... 44V  
 $\pm V_{SUPPLY}$  to Ground (V+, V-) .....  $\pm 22V$   
 Analog Input Voltage, (+V<sub>S</sub>) ..... +V<sub>SUPPLY</sub> +1.5V  
 (-V<sub>S</sub>) ..... -V<sub>SUPPLY</sub> -1.5V  
 Digital Input Voltage, (+V<sub>A</sub>) ..... +V<sub>SUPPLY</sub> +4V  
 (-V<sub>A</sub>) ..... -V<sub>SUPPLY</sub> -4V  
 Peak Current (S or D)  
 (Pulse at 1ms, 10% Duty Cycle Max) ..... 40mA  
 Continuous Current ..... 30mA  
 Junction Temperature ..... +175°C  
 Storage Temperature Range ..... -65°C to +150°C  
 Lead Temperature (Soldering 10 sec) .....  $\leq 275^\circ C$

**Thermal Information**

Thermal Resistance  $\theta_{JA}$  (°C/W)  $\theta_{JC}$  (°C/W)  
 CERDIP Package ..... 88 24  
 Package Power Dissipation at 75°C  
 Ceramic DIP Package ..... 0.85W/°C  
 Package Power Dissipation Derating Factor above +75°C  
 Ceramic DIP Package ..... 11.36mW/°C

**Recommended Operating Conditions**

Operating Temperature Range ..... -55°C to +125°C  
 Operating Supply Voltage Range ( $\pm V_{SUPPLY}$ ) .....  $\pm 15V$   
 Analog Input Voltage (V<sub>S</sub>) .....  $\pm V_{SUPPLY}$   
 Logic Low Level (V<sub>AL</sub>) ..... 0V to 0.8V  
 Logic High Level (V<sub>AH</sub>) ..... 4.0V to +V<sub>SUPPLY</sub>

CAUTION: Stresses above those listed in "Absolute Maximum Ratings" may cause permanent damage to the device. This is a stress only rating and operation of the device at these or any other conditions above those indicated in the operational sections of this specification is not implied.

**TABLE 1. D.C. ELECTRICAL PERFORMANCE SPECIFICATIONS**

Device Tested at: +V<sub>SUPPLY</sub> = +15V, -V<sub>SUPPLY</sub> = -15V, GND = 0V, Unless Otherwise Specified.

| D.C. PARAMETERS              | SYMBOL              | CONDITIONS   | GROUP A SUBGROUPS | TEMPERATURE (°C) | MIN  | MAX | UNITS |
|------------------------------|---------------------|--|-------------------|------------------|------|-----|-------|
| Switch "ON" Resistance       | r <sub>DS</sub>     | V <sub>A1</sub> = 4.0V, V <sub>D</sub> = 10V, I <sub>S</sub> = -10mA, V <sub>A2</sub> = 0.8V, S <sub>1</sub> /S <sub>2</sub> /S <sub>3</sub> /S <sub>4</sub> | 1                 | 25               | -    | 50  | Ω     |
|                              |                     |  | 2, 3              | -55 to 125       | -    | 75  | Ω     |
|                              |                     | V <sub>A1</sub> = 0.8V, V <sub>D</sub> = -10V, I <sub>S</sub> = 10mA, V <sub>A2</sub> = 4.0V, S <sub>1</sub> /S <sub>2</sub> /S <sub>3</sub> /S <sub>4</sub> | 1                 | 25               | -    | 50  | Ω     |
|                              |                     |  | 2, 3              | -55 to 125       | -    | 75  | Ω     |
| Source "OFF" Leakage Current | I <sub>S(OFF)</sub> | V <sub>S</sub> = +14V, V <sub>D</sub> = -14V, V <sub>A1</sub> = 0.8V, V <sub>A2</sub> = 4.0V, S <sub>1</sub> /S <sub>2</sub> /S <sub>3</sub> /S <sub>4</sub> | 1                 | 25               | -1   | 1   | nA    |
|                              |                     |  | 2, 3              | -55 to 125       | -100 | 100 | nA    |
|                              |                     | V <sub>S</sub> = -14V, V <sub>D</sub> = +14V, V <sub>A1</sub> = 4.0V, V <sub>A2</sub> = 0.8V, S <sub>1</sub> /S <sub>2</sub> /S <sub>3</sub> /S <sub>4</sub> | 1                 | 25               | -1   | 1   | nA    |
|                              |                     |  | 2, 3              | -55 to 125       | -100 | 100 | nA    |
| Drain "OFF" Leakage Current  | I <sub>D(OFF)</sub> | V <sub>S</sub> = +14V, V <sub>D</sub> = -14V, V <sub>A1</sub> = 0.8V, V <sub>A2</sub> = 4.0V, S <sub>1</sub> /S <sub>2</sub> /S <sub>3</sub> /S <sub>4</sub> | 1                 | 25               | -1   | 1   | nA    |
|                              |                     |  | 2, 3              | -55 to 125       | -100 | 100 | nA    |
|                              |                     | V <sub>S</sub> = -14V, V <sub>D</sub> = +14V, V <sub>A1</sub> = 4.0V, V <sub>A2</sub> = 0.8V, S <sub>1</sub> /S <sub>2</sub> /S <sub>3</sub> /S <sub>4</sub> | 1                 | 25               | -1   | 1   | nA    |
|                              |                     |  | 2, 3              | -55 to 125       | -100 | 100 | nA    |
| Channel "ON" Leakage Current | I <sub>D(ON)</sub>  | V <sub>D</sub> = V <sub>S</sub> = +14V, V <sub>A1</sub> = 4.0V, V <sub>A2</sub> = 0.8V, S <sub>1</sub> /S <sub>2</sub> /S <sub>3</sub> /S <sub>4</sub>       | 1                 | 25               | -1   | 1   | nA    |
|                              |                     |  | 2, 3              | -55 to 125       | -100 | 100 | nA    |
|                              |                     | V <sub>D</sub> = V <sub>S</sub> = -14V, V <sub>A1</sub> = 0.8V, V <sub>A2</sub> = 4.0V, S <sub>1</sub> /S <sub>2</sub> /S <sub>3</sub> /S <sub>4</sub>       | 1                 | 25               | -1   | 1   | nA    |
|                              |                     |  | 2, 3              | -55 to 125       | -100 | 100 | nA    |
| Low Level Input Current      | I <sub>AL</sub>     | All Channels V <sub>AL</sub> = 0.8V  | 1                 | 25               | -1.0 | 1.0 | μA    |
|                              |                     |  | 2, 3              | -55 to 125       | -1.0 | 1.0 | μA    |
| High Level Input Current     | I <sub>AH</sub>     | All Channels V <sub>AH</sub> = 4.0V  | 1                 | 25               | -1.0 | 1.0 | μA    |
|                              |                     |  | 2, 3              | -55 to 125       | -1.0 | 1.0 | μA    |
| Supply Current               | +I <sub>CC</sub>    | All Channels V <sub>A</sub> = 0.8V   | 1                 | 25               | -    | 10  | μA    |
|                              |                     |  | 2, 3              | -55 to 125       | -    | 100 | μA    |
|                              |                     | V <sub>A1</sub> = 0V, V <sub>A2</sub> = 4.0V and V <sub>A1</sub> = 4.0V, V <sub>A2</sub> = 0V  | 1                 | 25               | -    | 0.5 | mA    |
|                              |                     |  | 2, 3              | -55 to 125       | -    | 1.0 | mA    |
| Supply Current               | -I <sub>CC</sub>    | All Channels V <sub>A</sub> = 0.8V   | 1                 | 25               | -10  | -   | μA    |
|                              |                     |  | 2, 3              | -55 to 125       | -100 | -   | μA    |
|                              |                     | V <sub>A1</sub> = 0V, V <sub>A2</sub> = 4.0V and V <sub>A1</sub> = 4.0V, V <sub>A2</sub> = 0V  | 1                 | 25               | -10  | -   | μA    |
|                              |                     |  | 2, 3              | -55 to 125       | -100 | -   | μA    |

**TABLE 2. A.C. ELECTRICAL PERFORMANCE SPECIFICATIONS**

Device Tested at: +V<sub>SUPPLY</sub> = +15V, -V<sub>SUPPLY</sub> = -15V, GND = 0V, Unless Otherwise Specified.

| PARAMETERS      | SYMBOL           | CONDITIONS                                      | GROUP A SUB-GROUPS | TEMPERATURE (°C) | MIN | MAX | UNITS |
|-----------------|------------------|---|--------------------|------------------|-----|-----|-------|
| Turn "ON" Time  | t <sub>ON</sub>  | C <sub>L</sub> = 33pF,<br>R <sub>L</sub> = 300Ω | 9                  | 25               | -   | 300 | ns    |
|                 |                  |   | 10, 11             | 55 to 125        | -   | 500 | ns    |
| Turn "OFF" Time | t <sub>OFF</sub> | C <sub>L</sub> = 33pF,<br>R <sub>L</sub> = 300Ω | 9                  | 25               | -   | 250 | ns    |
|                 |                  |   | 10, 11             | 55 to 125        | -   | 450 | ns    |

**TABLE 3. ELECTRICAL PERFORMANCE SPECIFICATIONS (NOTE 1)**

Device Tested at: +V<sub>SUPPLY</sub> = +15V, -V<sub>SUPPLY</sub> = -15V, GND = 0V, Unused Pins are Grounded.

| PARAMETERS                 | SYMBOL                | CONDITIONS                                     | NOTE | TEMPERATURE (°C) | MIN | MAX | UNITS |
|----------------------------|-----------------------|--|------|------------------|-----|-----|-------|
| Switches Input Capacitance | C <sub>IS (OFF)</sub> | Measured Source to GND                         | 1    | 25               | -   | 28  | pF    |
| Driver Input Capacitance   | C <sub>C1</sub>       | V <sub>A</sub> = 0V                            | 1    | 25               | -   | 10  | pF    |
|                            | C <sub>C2</sub>       | V <sub>A</sub> = 15V                           | 1    | 25               | -   | 10  | pF    |
| Switch Output Capacitance  | C <sub>OS</sub>       | Measured Drain to GND                          | 1    | 25               | -   | 28  | pF    |
| Off Isolation              | V <sub>ISO</sub>      | f = 1MHz, V <sub>GEN</sub> = 1V <sub>P-P</sub> | 1    | 25               | 40  | -   | dB    |
| Cross Talk                 | V <sub>CT</sub>       | f = 1MHz, V <sub>GEN</sub> = 1V <sub>P-P</sub> | 1    | 25               | 40  | -   | dB    |
| Charge Transfer            | V <sub>CTE</sub>      | V <sub>S</sub> = GND, C <sub>L</sub> + 0.01μF  | 1    | 25               | -   | 15  | mV    |

NOTE:

- Parameters listed in Table 2 are controlled via design or process parameters and are not directly tested at final production. These parameters are lab characterized upon initial design release, or upon design changes. These parameters are guaranteed by characterization based upon data from multiple production runs which reflect lot to lot and within lot variation.

**TABLE 4. ELECTRICAL TEST REQUIREMENTS**

| MIL-STD-883 TEST REQUIREMENTS               | SUBGROUPS (Tables 1 and 2)  |
|---|-----------------------------|
| Interim Electrical Parameters (Pre Burn-in) | 1                           |
| Final Electrical Test Parameters            | 1 (Note 2), 2, 3, 9, 10, 11 |
| Group A Test Requirements                   | 1, 2, 3, 9, 10, 11          |
| Groups C & D Endpoints                      | 1                           |

NOTE:

- PDA applies to Subgroup 1 only.

Test Circuits

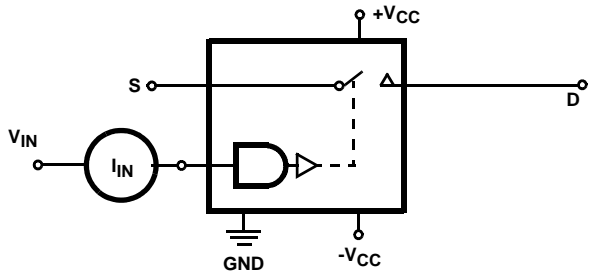

FIGURE 1. INPUT LEAKAGE CURRENT

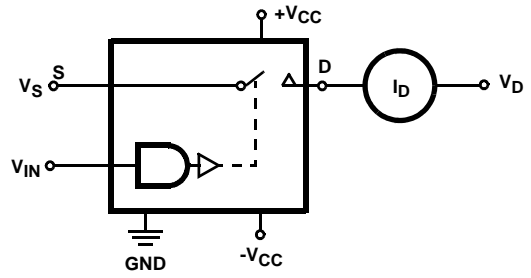

FIGURE 2.  $I_D$  (OFF)

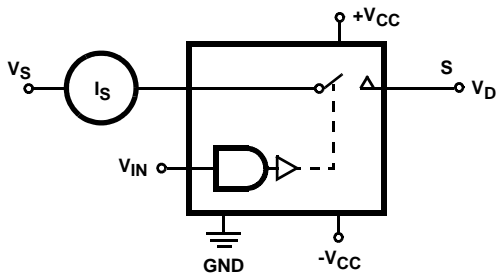

FIGURE 3.  $I_S$  (OFF)

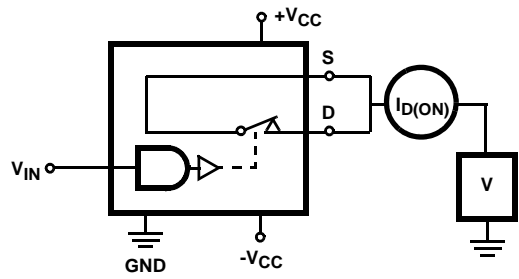

FIGURE 4.  $I_D$  (ON)

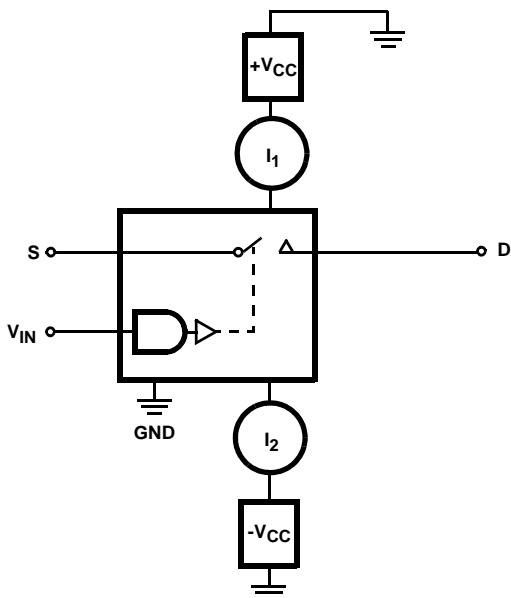
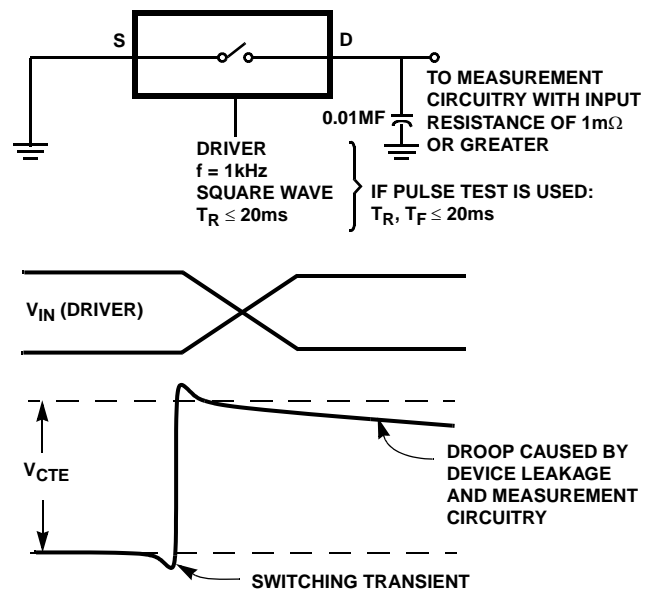

FIGURE 5. SUPPLY CURRENTS



NOTE:  $V_{CTE}$  may be a positive or negative value.

FIGURE 6. CHARGE TRANSFER ERROR

Test Circuits (Continued)

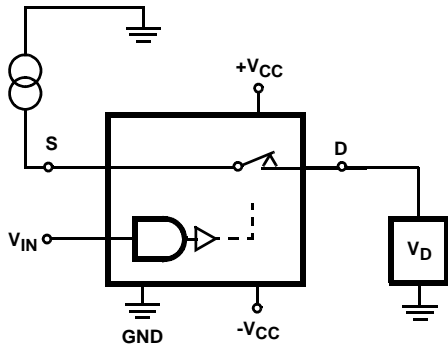

FIGURE 7.  $R_{DS}$

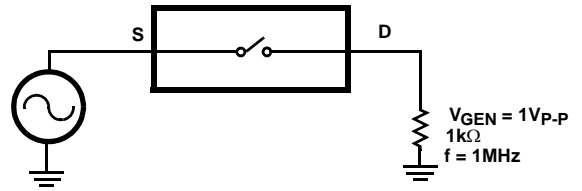

FIGURE 8. OFF CHANNEL ISOLATION

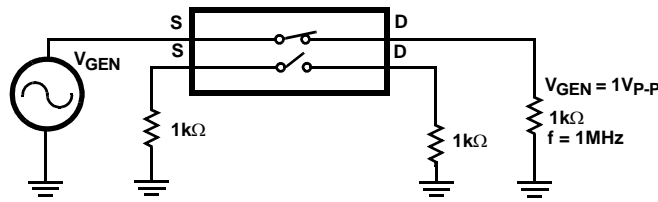

FIGURE 9. CROSSTALK BETWEEN CHANNELS

Test Waveforms

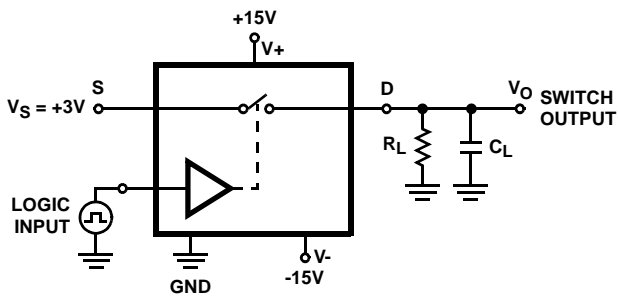

FIGURE 10.

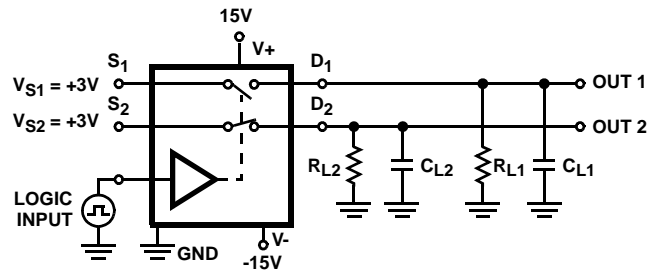

FIGURE 11.

Test Waveforms (Continued)

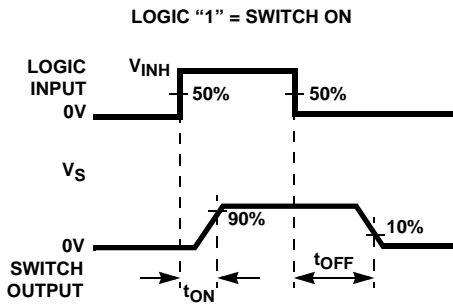

FIGURE 12. MEASUREMENT POINTS

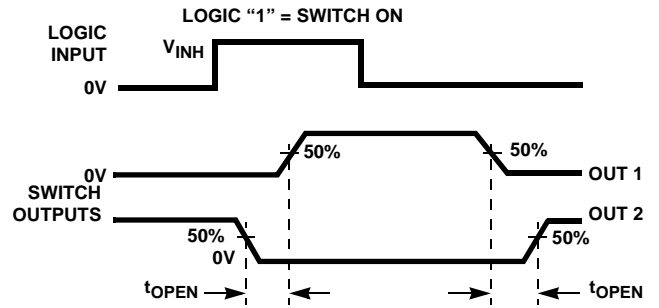
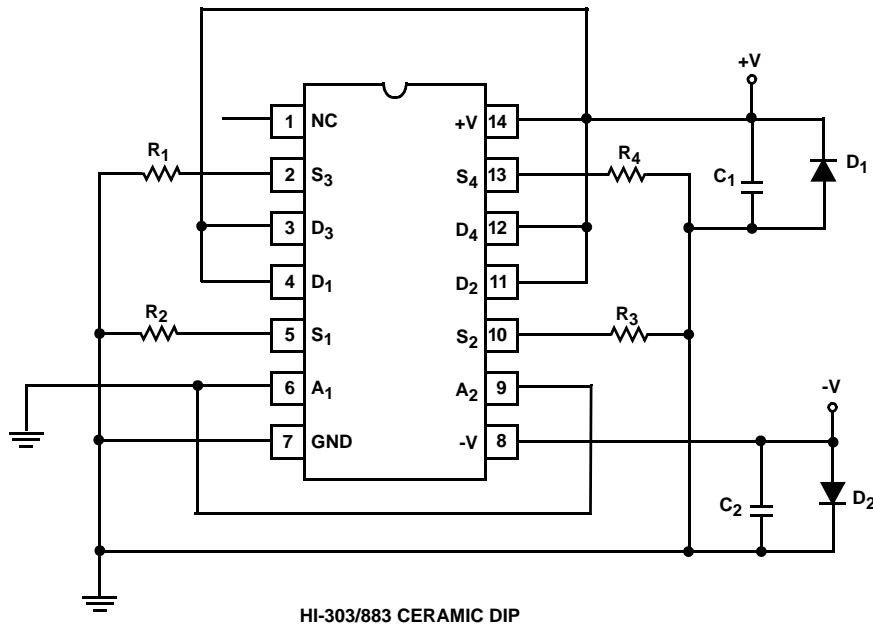

FIGURE 13. TTL LOGIC INPUT

NOTES:

- 3.  $R_L = R_{L1} = R_{L2} = 300\Omega$ ;  $C_L = C_{L1} = C_{L2} = 33pF$
- 4.  $V_{INH} = 4V$   
 RISETIME (0.4V to 3.6V)  $\leq 20ns$   
 FALLTIME (3.6V to 0.4V)  $\leq 20ns$

Burn-In Circuit



HI-303/883 CERAMIC DIP

NOTES:

- 5.  $R_1 = R_2 = R_3 = R_4 = 10k\Omega$ , 5%, 1/4 or 1/2W
- 6.  $C_1 = C_2 = 0.01\mu F$  (per socket) or  $0.1\mu F$  (per row)
- 7.  $D_1 = D_2 = IN4002$  (per board)
- 8.  $|(V+) - (V-)| = 30V$

**Schematic Diagram**

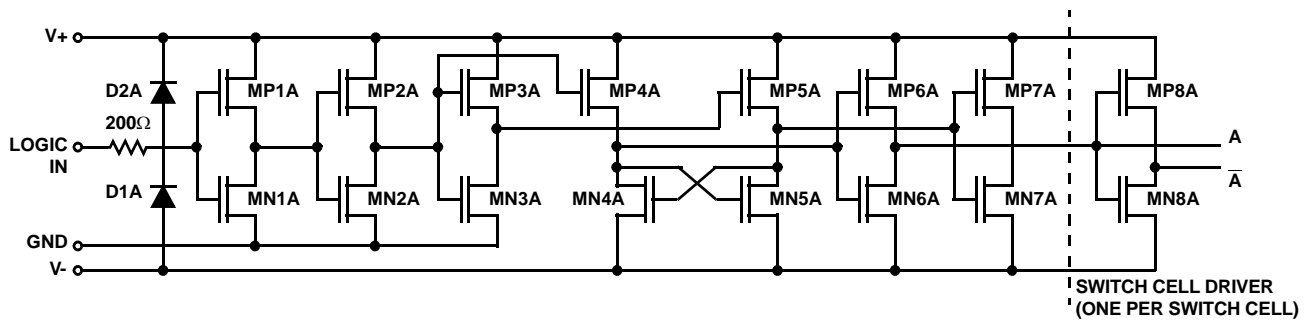

FIGURE 14. DIGITAL INPUT BUFFER AND LEVEL SHIFTER

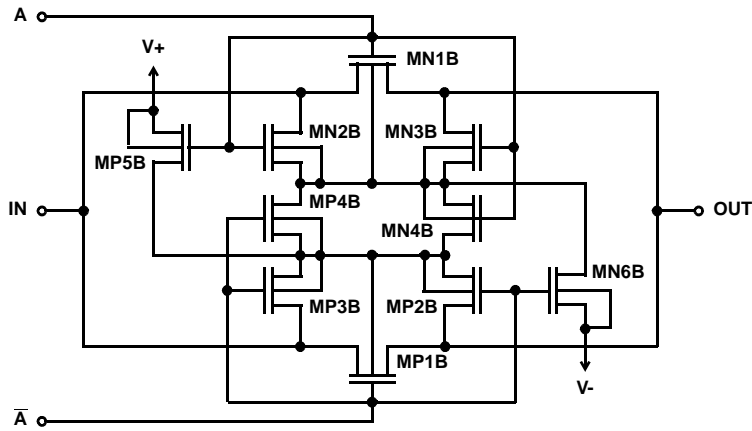

FIGURE 15. SWITCH CELL

**Typical Performance Curves**  $T_A = 25^\circ\text{C}$ ,  $V_+ = +15\text{V}$ ,  $V_- = -15\text{V}$ , Unless Otherwise Specified.

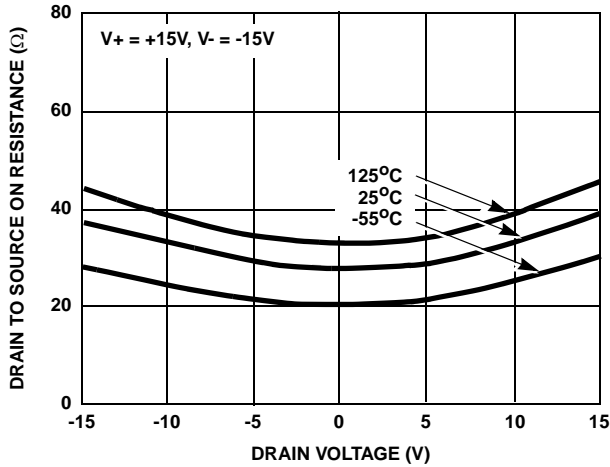

FIGURE 16.  $r_{DS(ON)}$  vs  $V_D$  AND TEMPERATURE

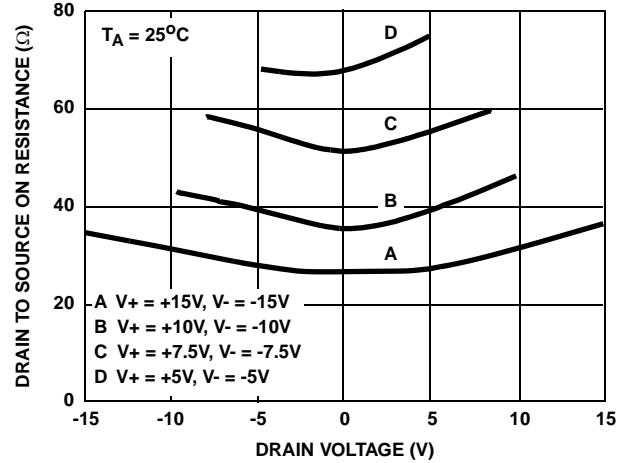

FIGURE 17.  $r_{DS(ON)}$  vs  $V_D$  AND POWER SUPPLY VOLTAGE

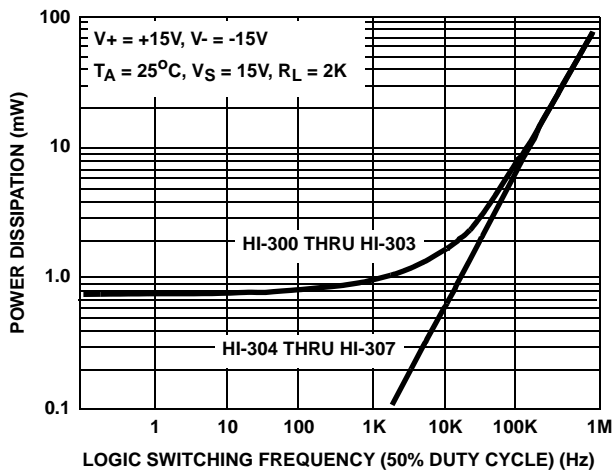

FIGURE 18. DEVICE POWER DISSIPATION vs SWITCHING FREQUENCY (SINGLE LOGIC INPUT)

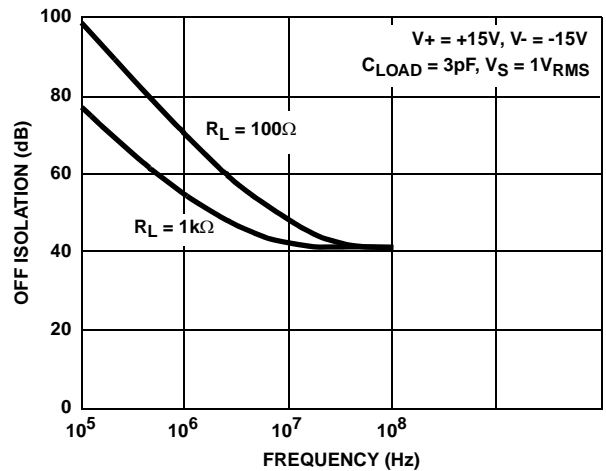

FIGURE 19. OFF ISOLATION vs FREQUENCY

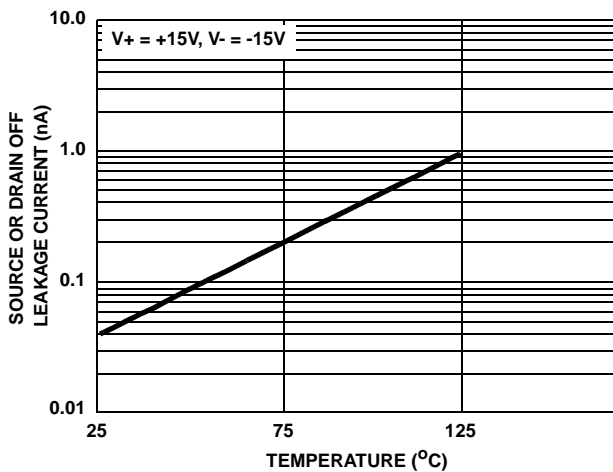

FIGURE 20.  $I_{S(OFF)}$  OR  $I_{D(OFF)}$  vs TEMPERATURE (Note)

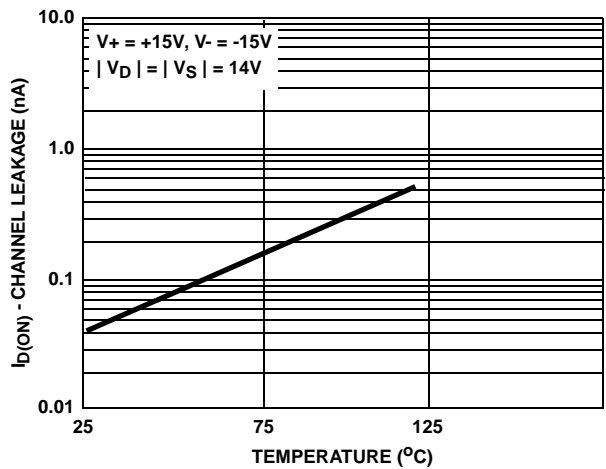

FIGURE 21.  $I_{D(ON)}$  vs TEMPERATURE (Note)

NOTE:

The net leakage into the source or drain is the N-Channel leakage minus the P-Channel leakage. This difference can be positive, negative or zero depending on the analog voltage and temperature, and will vary greatly from unit to unit.



**Typical Performance Curves**  $T_A = 25^\circ\text{C}$ ,  $V_+ = +15\text{V}$ ,  $V_- = -15\text{V}$ , Unless Otherwise Specified. (Continued)

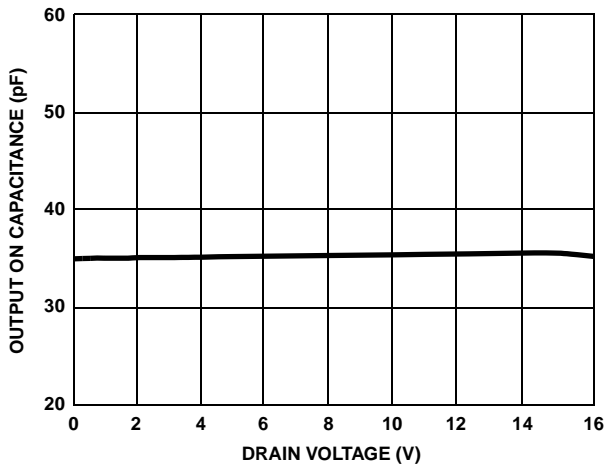

FIGURE 22. OUTPUT ON CAPACITANCE vs DRAIN VOLTAGE

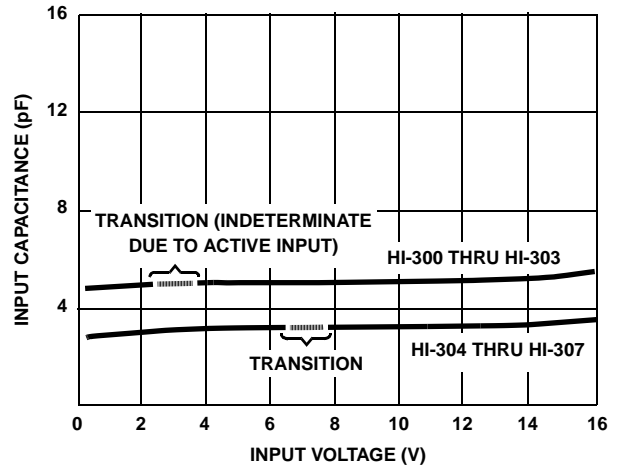

FIGURE 23. DIGITAL INPUT CAPACITANCE vs INPUT VOLTAGE

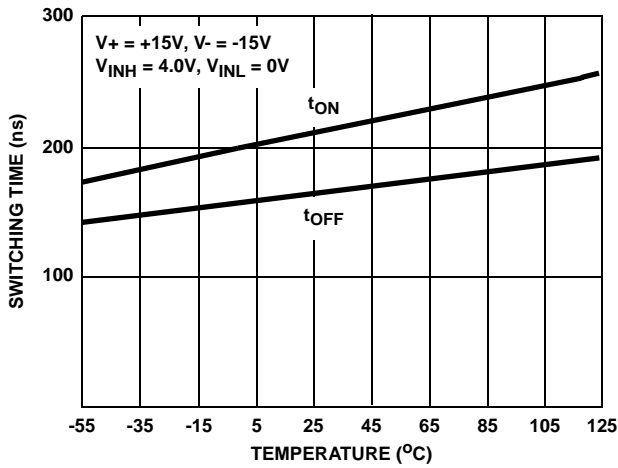

FIGURE 24. SWITCHING TIME vs TEMPERATURE

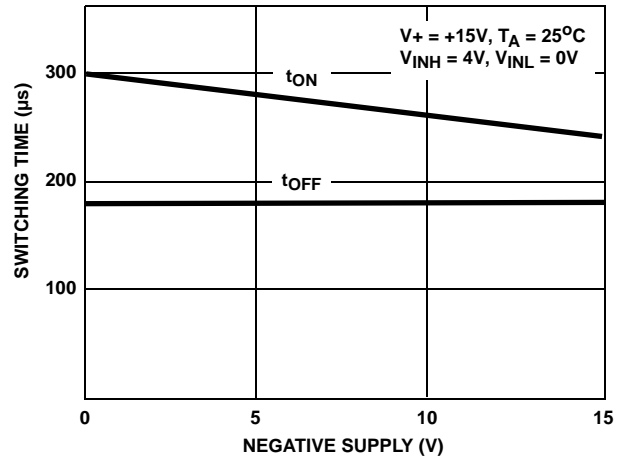

FIGURE 25. SWITCHING TIME vs NEGATIVE SUPPLY VOLTAGE

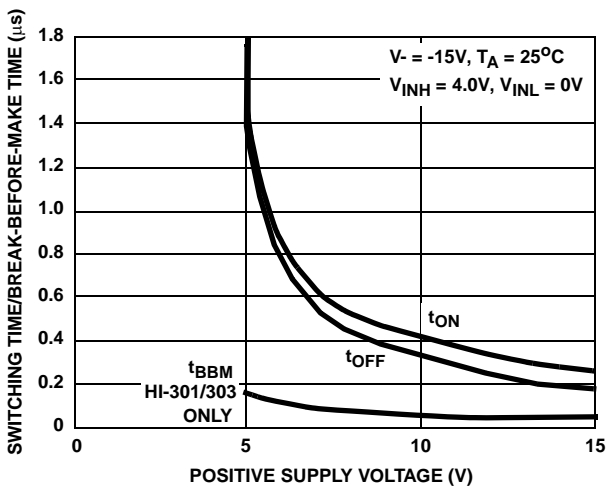

FIGURE 26. SWITCHING TIME AND BREAK-BEFORE-MAKE TIME vs POSITIVE SUPPLY VOLTAGE

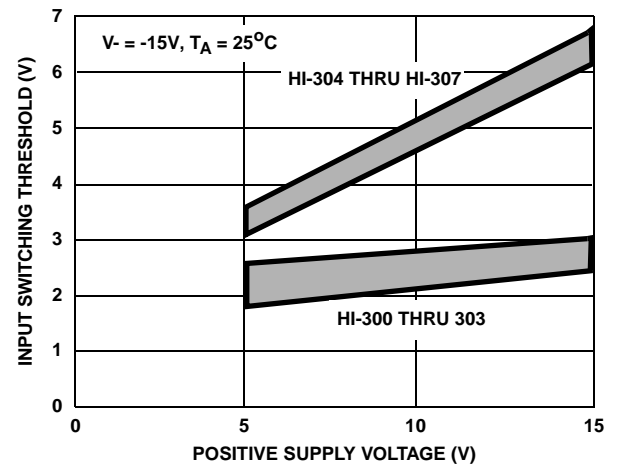

FIGURE 27. INPUT SWITCHING THRESHOLD vs POSITIVE SUPPLY VOLTAGE

**Die Characteristics**

**DIE DIMENSIONS:**

76 mils x 83.9 mils x 19 mils

**METALLIZATION:**

Type: Aluminum  
 Thickness:  $16\text{k}\text{\AA} \pm 2\text{k}\text{\AA}$

**GLASSIVATION:**

Type: Nitride  
 Thickness:  $7\text{k}\text{\AA} \pm 0.7\text{k}\text{\AA}$

**DIE ATTACH:**

Material: Gold/Silicon Eutectic Alloy  
 Temperature: Ceramic DIP - 460°C (Max)

**WORST CASE CURRENT DENSITY:**

$3.9 \times 10^5 \text{A/cm}^2$  at 30mA  
 This device meets Glassivation Integrity Test requirement per MIL-STD-883 Method 2021 and MIL-M-38510 paragraph 3.5.5.4

**Metallization Mask Layout**

HI-303/883

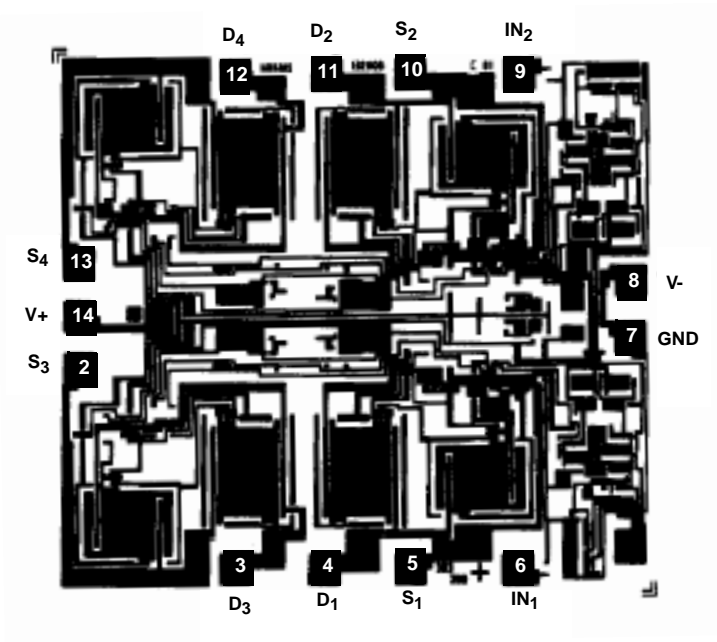

**Ceramic Dual-In-Line Frit Seal Packages (CERDIP)**

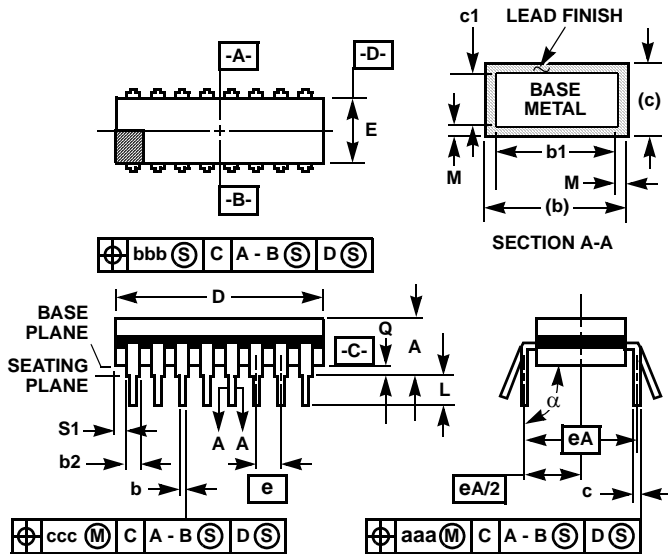

**F14.3 MIL-STD-1835 GDIP1-T14 (D-1, CONFIGURATION A)  
14 LEAD CERAMIC DUAL-IN-LINE FRIT SEAL PACKAGE**

| SYMBOL | INCHES    |        | MILLIMETERS |       | NOTES |
|--------|-----------|--------|-------------|-------|-------|
|        | MIN       | MAX    | MIN         | MAX   |       |
| A      | -         | 0.200  | -           | 5.08  | -     |
| b      | 0.014     | 0.026  | 0.36        | 0.66  | 2     |
| b1     | 0.014     | 0.023  | 0.36        | 0.58  | 3     |
| b2     | 0.045     | 0.065  | 1.14        | 1.65  | -     |
| b3     | 0.023     | 0.045  | 0.58        | 1.14  | 4     |
| c      | 0.008     | 0.018  | 0.20        | 0.46  | 2     |
| c1     | 0.008     | 0.015  | 0.20        | 0.38  | 3     |
| D      | -         | 0.785  | -           | 19.94 | 5     |
| E      | 0.220     | 0.310  | 5.59        | 7.87  | 5     |
| e      | 0.100 BSC |        | 2.54 BSC    |       | -     |
| eA     | 0.300 BSC |        | 7.62 BSC    |       | -     |
| eA/2   | 0.150 BSC |        | 3.81 BSC    |       | -     |
| L      | 0.125     | 0.200  | 3.18        | 5.08  | -     |
| Q      | 0.015     | 0.060  | 0.38        | 1.52  | 6     |
| S1     | 0.005     | -      | 0.13        | -     | 7     |
| α      | 90°       | 105°   | 90°         | 105°  | -     |
| aaa    | -         | 0.015  | -           | 0.38  | -     |
| bbb    | -         | 0.030  | -           | 0.76  | -     |
| ccc    | -         | 0.010  | -           | 0.25  | -     |
| M      | -         | 0.0015 | -           | 0.038 | 2, 3  |
| N      | 14        |        | 14          |       | 8     |

**NOTES:**

9. Index area: A notch or a pin one identification mark shall be located adjacent to pin one and shall be located within the shaded area shown. The manufacturer's identification shall not be used as a pin one identification mark.
10. The maximum limits of lead dimensions b and c or M shall be measured at the centroid of the finished lead surfaces, when solder dip or tin plate lead finish is applied.
11. Dimensions b1 and c1 apply to lead base metal only. Dimension M applies to lead plating and finish thickness.
12. Corner leads (1, N, N/2, and N/2+1) may be configured with a partial lead paddle. For this configuration dimension b3 replaces dimension b2.
13. This dimension allows for off-center lid, meniscus, and glass overrun.
14. Dimension Q shall be measured from the seating plane to the base plane.
15. Measure dimension S1 at all four corners.
16. N is the maximum number of terminal positions.
17. Dimensioning and tolerancing per ANSI Y14.5M - 1982.
18. Controlling dimension: INCH.

Rev. 0 4/94

All Intersil U.S. products are manufactured, assembled and tested utilizing ISO9000 quality systems. Intersil Corporation's quality certifications can be viewed at [www.intersil.com/design/quality](http://www.intersil.com/design/quality)

*Intersil products are sold by description only. Intersil Corporation reserves the right to make changes in circuit design, software and/or specifications at any time without notice. Accordingly, the reader is cautioned to verify that data sheets are current before placing orders. Information furnished by Intersil is believed to be accurate and reliable. However, no responsibility is assumed by Intersil or its subsidiaries for its use; nor for any infringements of patents or other rights of third parties which may result from its use. No license is granted by implication or otherwise under any patent or patent rights of Intersil or its subsidiaries.*

For information regarding Intersil Corporation and its products, see [www.intersil.com](http://www.intersil.com)