

Microprocessor-Compatible, Real-Time Clock

The ICM7170 real time clock is a microprocessor bus compatible peripheral, fabricated using Intersil's silicon gate CMOS LSI process. An 8-bit bidirectional bus is used for the data I/O circuitry. The clock is set or read by accessing the 8 internal separately addressable and programmable counters from $1/100$ seconds to years. The counters are controlled by a pulse train divided down from a crystal oscillator circuit, and the frequency of the crystal is selectable with the on-chip command register. An extremely stable oscillator frequency is achieved through the use of an on-chip regulated power supply.

The device access time (t_{ACC}) of 300ns eliminates the need for wait states or software overhead with most microprocessors. Furthermore, an ALE (Address Latch Enable) input is provided for interfacing to microprocessors with a multiplexed address/data bus. With these two special features, the ICM7170 can be easily interfaced to any available microprocessor.

The ICM7170 generates two types of interrupts, periodic and alarm. The periodic interrupt (100Hz, 10Hz, etc.) can be programmed by the internal interrupt control register to provide 6 different output signals. The alarm interrupt is set by loading an on-chip 51-bit RAM that activates an interrupt output through a comparator. The alarm interrupt occurs when the real time counter and alarm RAM time are equal. A status register is available to indicate the interrupt source.

An on-chip Power Down Detector eliminates the need for external components to support the battery back-up function. When a power down or power failure occurs, internal logic switches the on-chip counters to battery back-up operation. Read/write functions become disabled and operation is limited to time-keeping and interrupt generation, resulting in low power consumption.

Internal latches prevent clock roll-over during a read cycle. Counter data is latched on the chip by reading the 100th-seconds counter and is held indefinitely until the counter is read again, assuring a stable and reliable time value.

Features

- 8-Bit, μ P Bus Compatible
 - Multiplexed or Direct Addressing
- Regulated Oscillator Supply Ensures Frequency Stability and Low Power
- Time From 1/100 Seconds to 99 Years
- Software Selectable 12/24 Hour Format
- Latched Time Data Ensures No Roll Over During Read
- Full Calendar with Automatic Leap Year Correction
- On-Chip Battery Backup Switchover Circuit
- Access Time Less than 300ns
- 4 Programmable Crystal Oscillator Frequencies Over Industrial Temperature Range
- 3 Programmable Crystal Oscillator Frequencies Over Military Temperature Range
- On-Chip Alarm Comparator and RAM
- Interrupts from Alarm and 6 Selectable Periodic Intervals
- Standby Micro-Power Operation: 1.2 μ A Typical at 3.0V and 32kHz Crystal

Applications

- Portable and Personal Computers
- Data Logging
- Industrial Control Systems
- Point Of Sale

Related Literature

- Technical Brief TB363 "Guidelines for Handling and Processing Moisture Sensitive Surface Mount Devices (SMDs)"

Ordering Information

PART NUMBER	TEMP. RANGE (°C)	PACKAGE	PKG. NO.
ICM7170IPG	-40 to 85	24 Ld PDIP	E24.6
ICM7170IDG	-40 to 85	24 Ld SBDIP	D24.6
ICM7170IBG	-40 to 85	24 Ld SOIC	M24.3
ICM7170AIPG	-40 to 85	24 Ld PDIP	E24.6
ICM7170AIBG	-40 to 85	24 Ld SOIC	M24.3

NOTE: "A" Parts Screened to <5 μ A I_{STBY} at 32kHz.

ICM7170

Pinouts

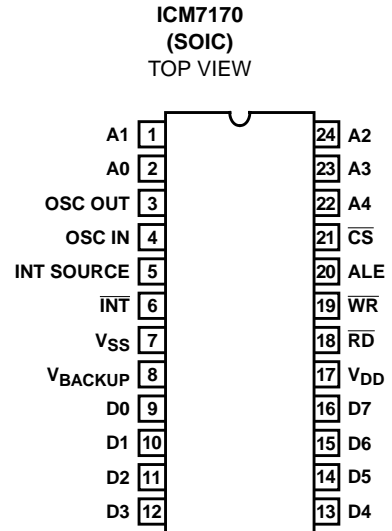
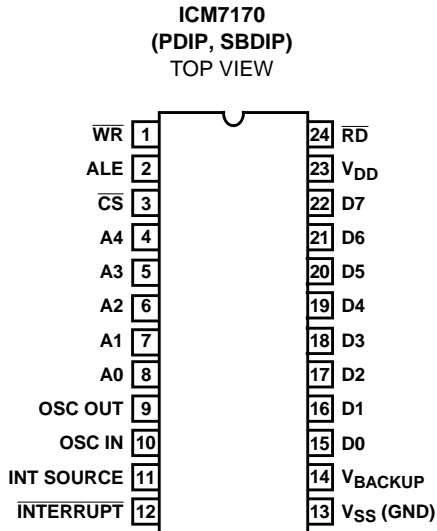

Functional Block Diagram

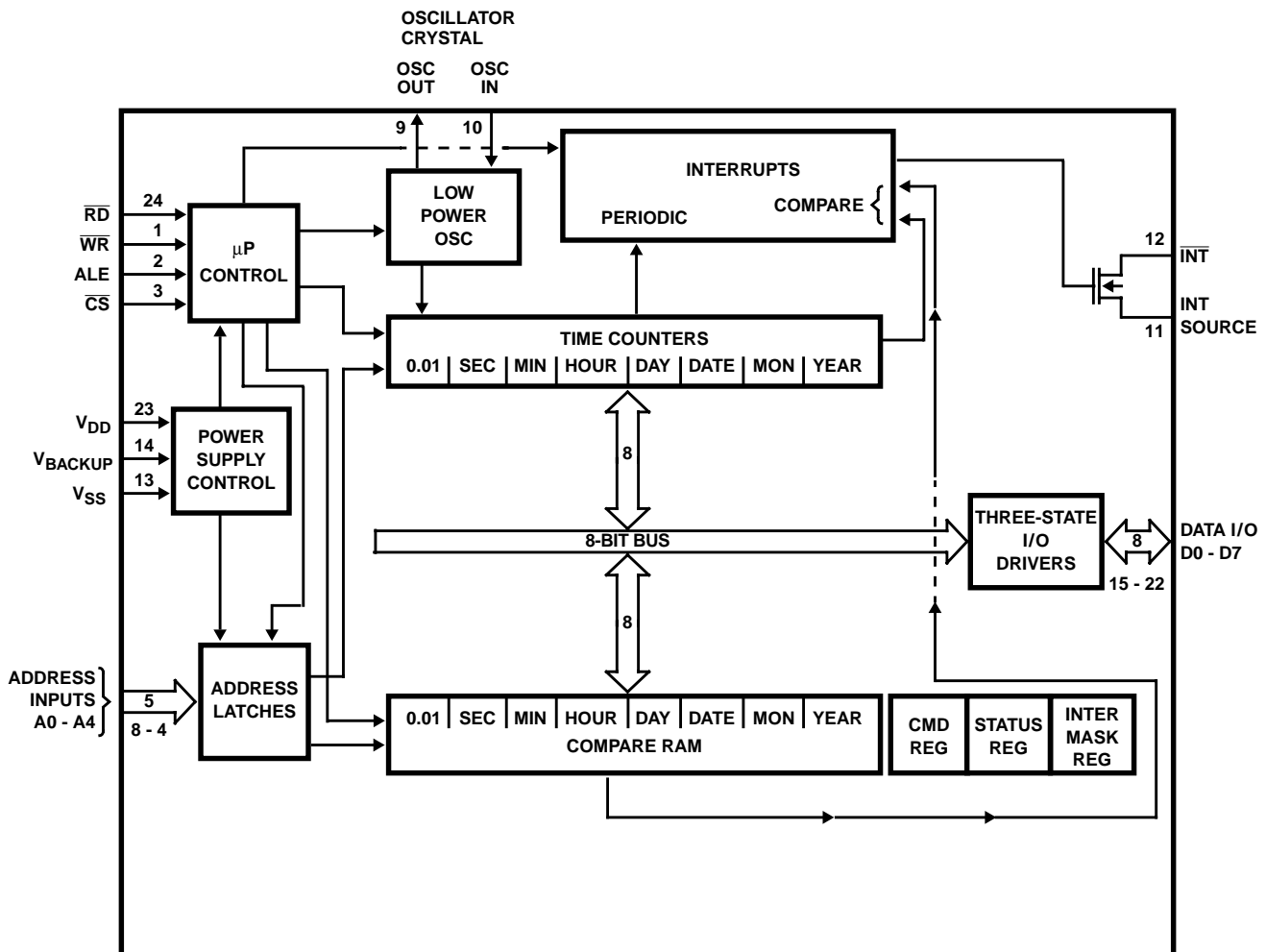

ICM7170

Absolute Maximum Ratings $T_A = 25^\circ\text{C}$

Supply Voltage	+8.0V
Power Dissipation (Note 1)	.500mW
Storage Temperature Range	-65°C to 150°C
Lead Temperature (Soldering 10s)	300°C
Input Voltage (Any Terminal) (Note 2)	$V_{DD} + 0.3\text{V}$ to $V_{SS} - 0.3\text{V}$

Thermal Information

Thermal Resistance (Typical, Note 1)	θ_{JA} (°C/W)	θ_{JC} (°C/W)
PDIP Package	50	N/A
SBDIP Package	75	30
SOIC Package	75	N/A
Maximum Junction Temperature		
Plastic Package		150°C
SBDIP Package		175°C

CAUTION: Stresses above those listed in "Absolute Maximum Ratings" may cause permanent damage to the device. This is a stress only rating and operation of the device at these or any other conditions above those indicated in the operational sections of this specification is not implied.

NOTE:

- θ_{JA} is measured with the component mounted on a low effective thermal conductivity test board in free air. See Tech Brief TB379 for details.
- Due to the SCR structure inherent in the CMOS process, connecting any terminal at voltages greater than V_{DD} or less than V_{SS} may cause destructive device latchup. For this reason, it is recommended that no inputs from external sources not operating on the same power supply be applied to the device before its supply is established, and that in multiple supply systems, the supply to the ICM7170 be turned on first.

Electrical Specifications $T_A = -40^\circ\text{C}$ to 85°C , $V_{DD} + 5\text{V} \pm 10\%$, $V_{BACKUP} = V_{DD}$, $V_{SS} = 0\text{V}$ Unless Otherwise Specified All I_{DD} specifications include all input and output leakages (ICM7170 and ICM7170A)

PARAMETER	TEST CONDITIONS	MIN	TYP	MAX	UNITS
V_{DD} Supply Range, V_{DD}	$f_{OSC} = 32\text{kHz}$	1.9	-	5.5	V
	$f_{OSC} = 1, 2, 4\text{MHz}$	2.6	-	5.5	V
Standby Current, $I_{STBY(1)}$	$f_{OSC} = 32\text{kHz}$ Pins 1 - 8, 15 - 22 and 24 = V_{DD}	-	1.2	20.0	μA
	$V_{DD} = V_{SS}$; $V_{BACKUP} = V_{DD} - 3.0\text{V}$ For ICM7170A See General Notes 5	-	1.2	5.0	μA
Standby Current, $I_{STBY(2)}$	$f_{OSC} = 4\text{MHz}$ Pins 1 - 8, 15 - 22 and 24 = V_{DD} $V_{DD} = V_{SS}$; $V_{BACKUP} = V_{DD} - 3.0\text{V}$	-	20	150	μA
Operating Supply Current, $I_{DD(1)}$	$f_{OSC} = 32\text{kHz}$, Read/Write Operation at 100Hz	-	0.3	1.2	mA
Operating Supply Current, $I_{DD(2)}$	$f_{OSC} = 32\text{kHz}$, Read/Write Operation at 1MHz	-	1.0	2.0	mA
Input Low Voltage (Except Osc.), V_{IL}	$V_{DD} = 5.0\text{V}$	-	-	0.8	V
Input High Voltage (Except Osc.), V_{IH}	$V_{DD} = 5.0\text{V}$	2.4	-	-	V
Output Low Voltage (Except Osc.), V_{OL}	$I_{OL} = 1.6\text{mA}$	-	-	0.4	V
Output High Voltage Except INTERRUPT (Except Osc.), V_{OH}	$I_{OH} = -400\mu\text{A}$	2.4	-	-	V
Input Leakage Current, I_{IL}	$V_{IN} = V_{DD}$ or V_{SS}	-10	0.5	+10	μA
Three-State Leakage Current (D0 - D7), $I_{OL(1)}$	$V_O = V_{DD}$ or V_{SS}	-10	0.5	+10	μA
Backup Battery Voltage, $V_{BATTERY}$	$f_{OSC} = 1, 2, 4\text{MHz}$	2.6	-	$V_{DD} - 1.3$	V
Backup Battery Voltage, $V_{BATTERY}$	$f_{OSC} = 32\text{kHz}$	1.9	-	$V_{DD} - 1.3$	V
Leakage Current INTERRUPT, $I_{OL(2)}$	$V_O = V_{DD}$	-	0.5	10	μA
	INT SOURCE Connected to V_{SS}				
Capacitance D0 - D7, $C_{I/O}$		-	8	-	pF
Capacitance A0 - A4, $C_{ADDRESS}$		-	6	-	pF

ICM7170

AC Electrical Specifications $T_A = -40^{\circ}\text{C}$ to 85°C , $V_{DD} = +5\text{V} \pm 10\%$, $V_{\text{BACKUP}} = V_{DD}$,
 $D0 - D7$ Load Capacitance = 150pF , $V_{IL} = 0.4\text{V}$, $V_{IH} = 2.8\text{V}$, Unless Otherwise Specified

PARAMETER	MIN	MAX	UNITS
READ CYCLE TIMING			
READ to DATA Valid, t_{RD}	-	250	ns
ADDRESS Valid to DATA Valid, t_{ACC}	-	300	ns
READ Cycle Time, t_{CYC}	400	-	ns
Read High Time, t_{RH}	150	-	ns
$\overline{\text{RD}}$ High to Bus Three-State, t_{RH}	-	25	ns
ADDRESS to READ Set Up Time, t_{AS}	50	-	ns
ADDRESS HOLD Time After READ, t_{AR}	0	-	ns
WRITE CYCLE TIMING			
ADDRESS Valid to WRITE Strobe, t_{AD}	50	-	ns
ADDRESS Hold Time for WRITE, t_{WA}	0	-	ns
WRITE Pulse Width, Low, t_{WL}	100	-	ns
WRITE High Time, t_{WH}	300	-	ns
DATA IN to WRITE Set Up Time, t_{DW}	100	-	ns
DATA IN Hold Time After WRITE, t_{WD}	30	-	ns
WRITE Cycle Time, t_{CYC}	400	-	ns
MULTIPLEXED MODE TIMING			
ALE Pulse Width, High, t_{LL}	50	-	ns
ADDRESS to ALE Set Up Time, t_{AL}	30	-	ns
ADDRESS Hold Time After ALE, t_{LA}	30	-	ns

Timing Diagrams

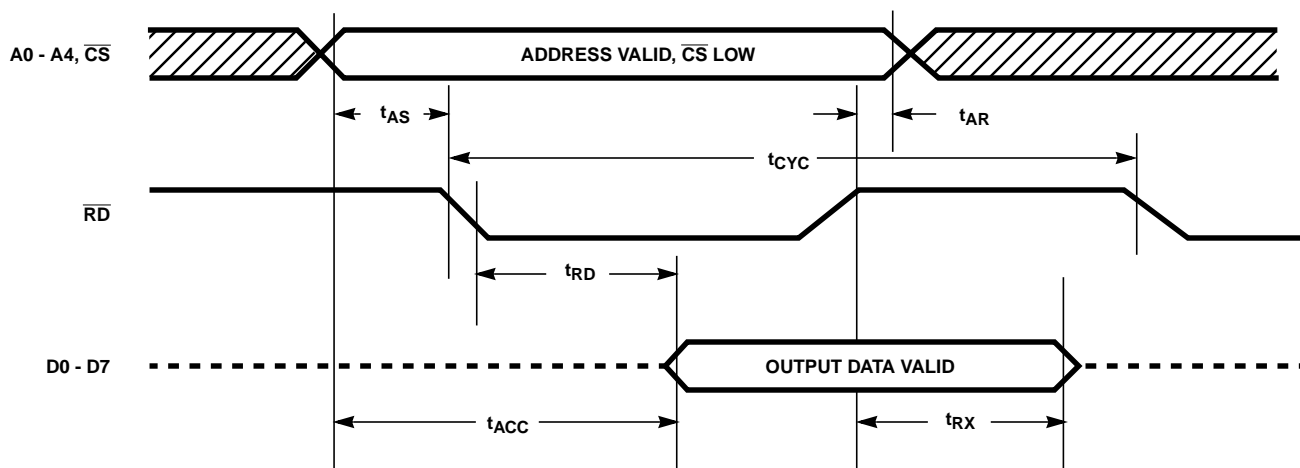

FIGURE 1. READ CYCLE TIMING FOR NON-MULTIPLEXED BUS (ALE = V_{IH} , $\overline{\text{WR}} = V_{IH}$)

Timing Diagrams (Continued)

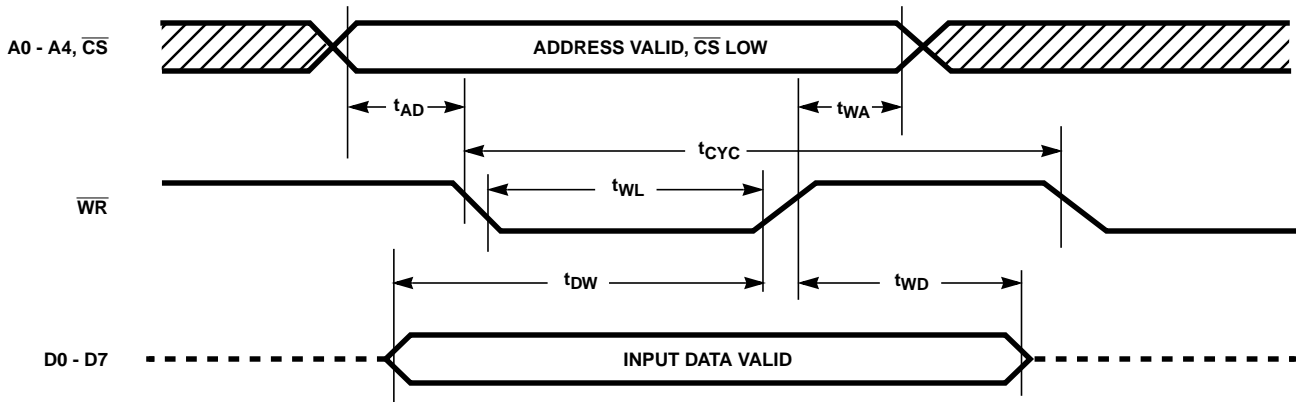

FIGURE 2. WRITE CYCLE TIMING FOR NON-MULTIPLEXED BUS (ALE = V_{IH} , $\overline{RD} = V_{IH}$)

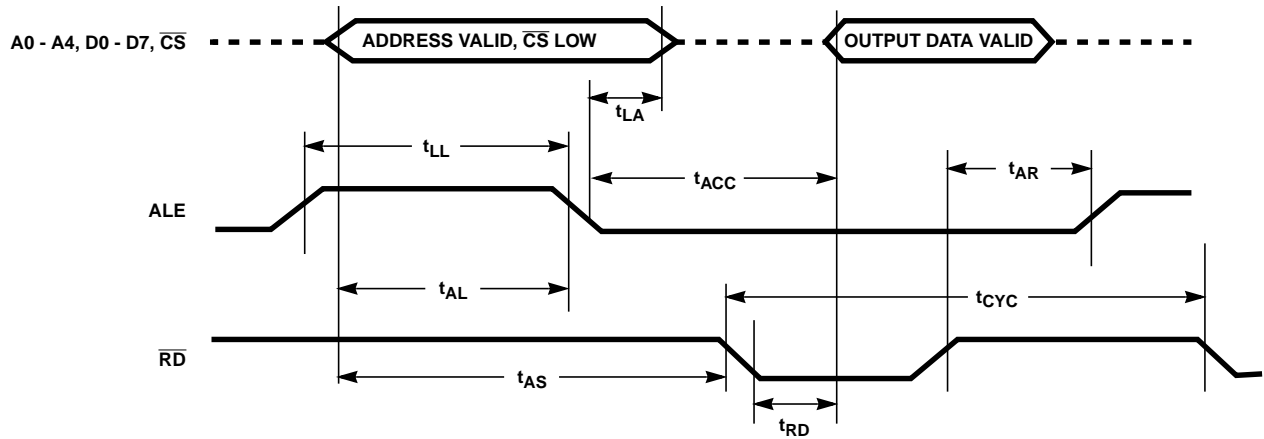

FIGURE 3. READ CYCLE TIMING FOR MULTIPLEXED BUS ($\overline{WR} = V_{IH}$)

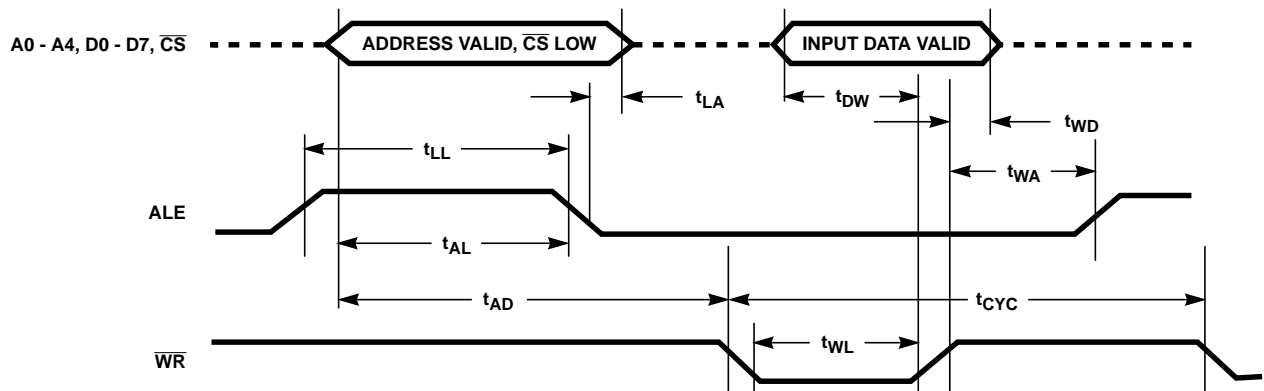

FIGURE 4. WRITE CYCLE TIMING FOR MULTIPLEXED BUS ($\overline{RD} = V_{IH}$)

Pin Descriptions

SIGNAL	PIN NUMBER	SOIC PIN NUMBER	DESCRIPTION
WR	1	19	Write Input
ALE	2	20	Address Latch Enable Input
CS	3	21	Chip Select Input
A4-A0	4 - 8	22 - 2	Address Inputs
OSC OUT	9	3	Oscillator Output
OSC IN	10	4	Oscillator Input
INT SOURCE	11	5	Interrupt Source
INTERRUPT	12	6	Interrupt Output
V _{SS} (GND)	13	7	Digital Common
V _{BACKUP}	14	8	Battery Negative Side
D0 - D7	15 - 22	9 - 16	Data I/O
V _{DD}	23	17	Positive Digital Supply
RD	24	18	Read Input

TABLE 1. COMMAND REGISTER FORMAT

COMMAND REGISTER ADDRESS (10001b, 11h) WRITE-ONLY							
D7	D6	D5	D4	D3	D2	D1	D0
n/a	n/a	Normal/Test Mode	Interrupt Enable	Run/Stop	12/24 Hour Format	Crystal Frequency	Crystal Frequency

TABLE 2. COMMAND REGISTER BIT ASSIGNMENTS

D5	TEST BIT	D4	INTERRUPT ENABLE	D3	RUN/STOP	D2	24/12 HOUR FORMAT	D1	D0	CRYSTAL FREQUENCY
0	Normal Mode	0	Interrupt disabled	0	Stop	0	12-Hour Mode	0	0	32.768kHz
1	Test Mode	1	Interrupt enable	1	Run	1	24-Hour Mode	0	1	1.048576MHZ
								1	0	2.097152MHz
								1	1	4.194304MHz

TABLE 3. ADDRESS CODES AND FUNCTIONS

ADDRESS						FUNCTION	DATA								VALUE
A4	A3	A2	A1	A0	HEX		D7	D6	D5	D4	D3	D2	D1	D0	
0	0	0	0	0	00	Counter-1/100 seconds	-								0 - 99
0	0	0	0	1	01	Counter-hours	-	-	-						0 - 23
						12 Hour Mode	†	-	-	-					1 - 12
0	0	0	1	0	02	Counter-minutes	-	-							0 - 59
0	0	0	1	1	03	Counter-seconds	-	-							0 - 59
0	0	1	0	0	04	Counter-month	-	-	-	-					1 - 12
0	0	1	0	1	05	Counter-date	-	-	-						1 - 31
0	0	1	1	0	06	Counter-year	-								0 - 99
0	0	1	1	1	07	Counter-day of week	-	-	-	-	-				0 - 6
0	1	0	0	0	08	RAM-1/100 seconds	M								0 - 99
0	1	0	0	1	09	RAM-hours	-	M	-						0 - 23
						12 Hour Mode	†	M	-	-					1 - 12
0	1	0	1	0	0A	RAM-minutes	M	-	.	.					0 - 59
0	1	0	1	1	0B	RAM-seconds	M	-	.	.					0 - 59
0	1	1	0	0	0C	RAM-month	M	-	-	-					1 - 12
0	1	1	0	1	0D	RAM-date	M	-	-						1 - 31
0	1	1	1	0	0E	RAM-year	M								0 - 99

TABLE 3. ADDRESS CODES AND FUNCTIONS (Continued)

ADDRESS						FUNCTION	DATA								VALUE
A4	A3	A2	A1	A0	HEX		D7	D6	D5	D4	D3	D2	D1	D0	
0	1	1	1	1	0F	RAM-day of week	M	-	-	-	-				0 - 6
1	0	0	0	0	10	Interrupt Status and Mask Register	+								
1	0	0	0	1	11	Command register	-	-							

NOTES:

Addresses 10010 to 11111 (12h to 1Fh) are unused.

'+' Unused bit for interrupt Mask Register, MSB bit for interrupt Status Register.

'-' Indicates unused bits.

'‡' AM/PM indicator bit in 12 hour format Logic "0" indicates AM, logic "1" indicates PM.

'M' Alarm compare for particular counter will be enabled if bit is set to logic "0".

TABLE 4. INTERRUPT AND STATUS REGISTERS FORMAT

INTERRUPT MASK REGISTER ADDRESS (10000b, 10h) WRITE-ONLY							
D7	D6	D5	D4	D3	D2	D1	D0
NOT USED	DAY	HOUR	MIN	SEC	1/10 SEC	1/100 SEC	ALARM
	← Periodic Interrupt Mask Bits →						Alarm/Compare Mask Bit
INTERRUPT STATUS REGISTER ADDRESS (10000b, 10h) READ-ONLY							
D7	D6	D5	D4	D3	D2	D1	D0
GLOBAL INTERRUPT	DAY	HOUR	MIN	SEC	1/10 SEC	1/100 SEC	ALARM
Periodic and Alarm Flags	← Periodic Interrupt Flags →						Alarm Compare Flag

Detailed Description

Oscillator

The ICM7170 has an onboard CMOS Pierce oscillator with an internally regulated voltage supply for maximum accuracy, stability, and low power consumption. It operates at any of four popular crystal frequencies: 32.768kHz, 1.046576MHz, 2.097152MHz, and 4.194304MHz (Note 1). The crystal should be designed for the parallel resonant mode of oscillation. In addition to the crystal, 2 or 3 load capacitors are required, depending on the circuit topology used.

The oscillator output is divided down to 4000Hz by one of four divider ratios, determined by the two frequency selection bits in the Command Register (D0 and D1 at address 11H). This 4000Hz is then divided down to 100Hz, which is used as the clock for the counters.

Time and calendar information is provided by 8 consecutive, programmable counters: 100ths of, seconds, minutes, hours, day of week, date, month, and year. The data is in binary format with 8 bits per digit. See Table 3 for address information. Any unused bits are held to a logic "0" during a read and ignored during a write operation.

NOTE:

1. 4.94304MHz is not available over military temperature range.

Alarm Compare RAM

On the chip are 51 bits of Alarm Compare RAM grouped into words of different lengths. These are used to store the time, ranging from 10ths of seconds to years, for comparison to the real-time counters. Each counter has a corresponding RAM

word. In the Alarm Mode an interrupt is generated when the current time is equal to the alarm time. The RAM contents are compared to the counters on a word by word basis. If a comparison to a particular counter is unnecessary, then the appropriate 'M' bit in Compare RAM should be set to logic "1".

The 'M' bit, referring to Mask bit, causes a particular RAM word to be masked off or ignored during a compare. Table 3 shows addresses and Mask bit information.

Periodic Interrupts

The interrupt output can be programmed for 6 periodic signals: 100Hz, 10Hz, once per second, once per minute, once per hour, or once per day. The 100Hz and 10Hz interrupts have instantaneous errors of ±2.5% and ±0.15% respectively. This is because non-integer divider circuitry is used to generate these signals from the crystal frequency, which is a power of 2. The time average of these errors over a 1 second period, however, is zero. Consequently, the 100Hz or 10Hz interrupts are not suitable as an aid in tuning the oscillator; the 1 second interrupt must be used instead.

See General Notes, Note 6.

The periodic interrupts can occur concurrently and in addition to alarm interrupts. The periodic interrupts are controlled by bits in the interrupt mask register, and are enabled by setting the appropriate bit to a "1" as shown in Table 4. Bits D1 through D6 in the mask register, in conjunction with bits D1 through D6 of the status register, control the generation of interrupts according to Figure 5.

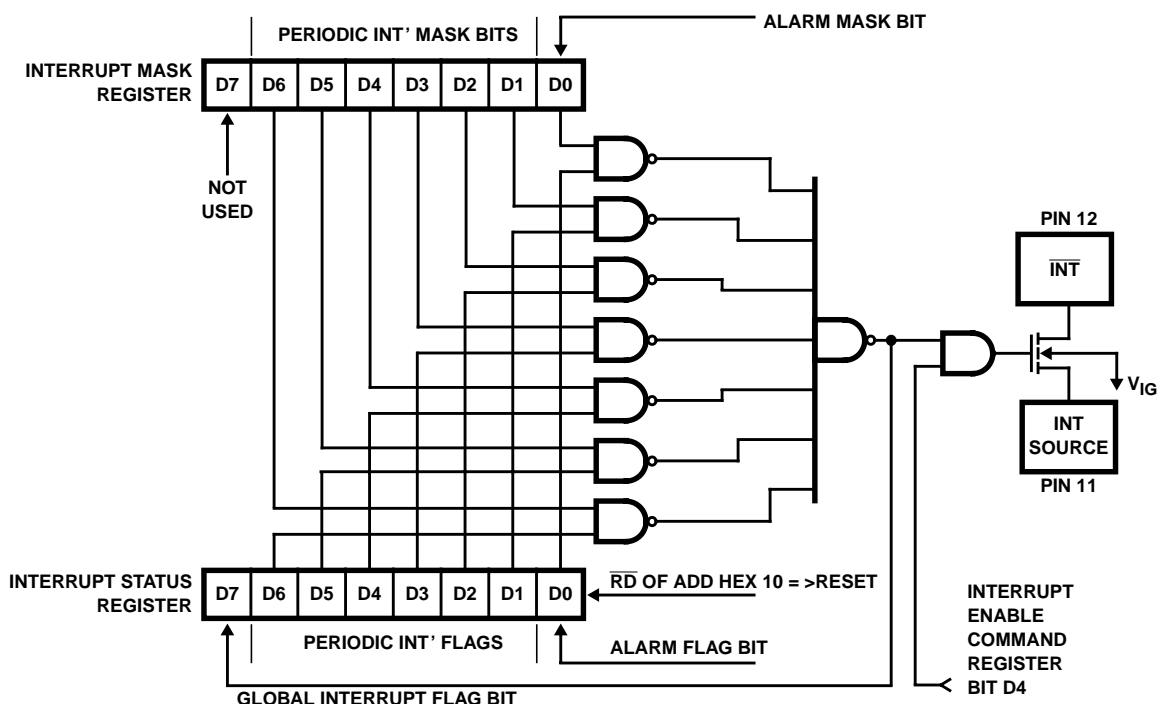

FIGURE 5. INTERRUPT OUTPUT CIRCUIT

The interrupt status register, when read, indicates the cause of the interrupt and resets itself on the rising edge of the RD signal. When any of the counters having a corresponding bit in the status register increments, that bit is set to a “1” regardless of whether the corresponding bit in the interrupt mask register is set or not.

Consequently, when the status register is read it will always indicate which counters have increments and if an alarm compare occurred, since the last time it was read. This requires some special software considerations. If a slow interrupt is enabled (i.e., hourly or daily), the program must always check the slowest interrupt that has been enabled first, because all the other lower order bits in the status register will be set to “1” as well.

Bit D7 is the global interrupt bit, and when set to a “1”, indicates that the ICM7170 did indeed generate a hardware interrupt. This is useful when other interrupting devices in addition to the ICM7170 are attached to the system microprocessor, and all devices must be polled to determine which one generated the interrupt.

See General Notes, Note 6.

Interrupt Operation

The Interrupt Output N-channel MOSFET (Figure 4) is enabled whenever both the Interrupt Enable bit (D4 of the Command Register) and a mask bit (D0 - D6 of the Interrupt Mask Register) are set. The transistor is turned ON when a flag bit is set that corresponds to one of the set mask bits. This also sets the Global Interrupt Flag Bit (D7 of the Interrupt Status Register). It is turned OFF when the Interrupt Status Register is

read. An interrupt can occur in both the operational and standby modes of operation.

Since system power is usually applied between V_{DD} and V_{SS} , the user can connect the Interrupt Source (pin 11) to V_{SS} . This allows the Interrupt Output to turn on only while system powers applied and will not be pulled to V_{SS} during standby operation. If interrupts are required only during standby operation, then the interrupt source pin should be connected to the battery's negative side (V_{BACKUP}). In this configuration, for example, the interrupt could be used to turn on power for a cold boot.

Power Down Detector

The ICM7170 contains an on-chip power down detector that eliminates the need for external components to support the battery-backup switchover function, as shown in Figure 6. Whenever the voltage from the V_{SS} pin to the V_{BACKUP} pin is less than approximately 1.0V (the V_{TH} of the N-channel MOSFET), the data bus I/O buffers in the ICM7170 are automatically disabled and the chip cannot be read or written to. This prevents random data from the microprocessor being written to the clock registers as the power supply is going down.

Actual switchover to battery operation occurs when the voltage on the V_{BACKUP} pin is within $\pm 50mV$ of V_{SS} . This switchover uncertainty is due to the offset voltage of the CMOS comparator that is used to sense the battery voltage. During battery backup, device operation is limited to timekeeping and interrupt generation only, thus achieving micro- power current drain. If an external battery-backup switch-over circuit is being used with the ICM7170, or if standby battery operation is not required, the V_{BACKUP} pin should be pulled up to V_{DD} through a 2K resistor.

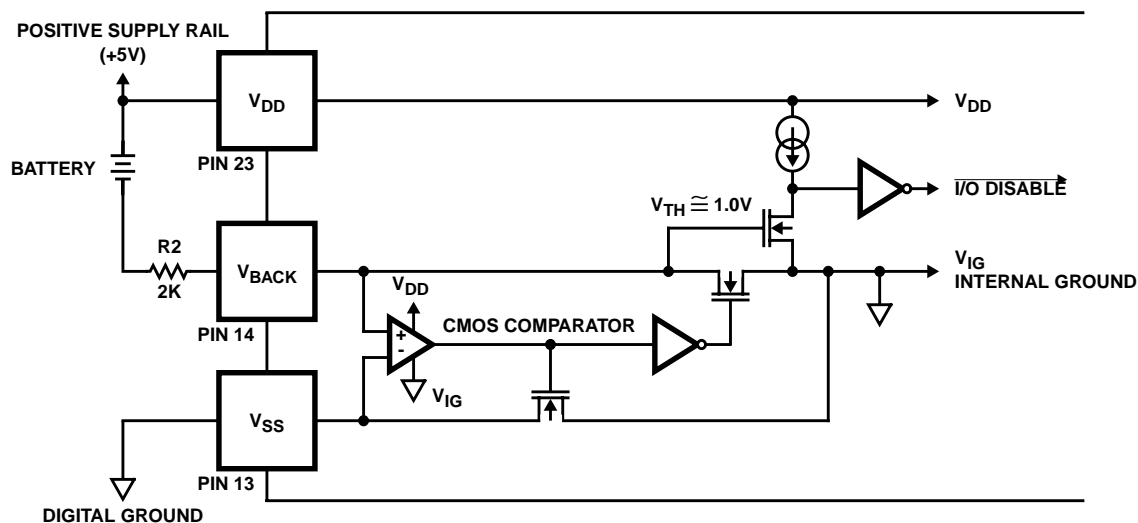

FIGURE 6. SIMPLIFIED ICM7170 BATTERY BACKUP CIRCUIT

Time Synchronization

Time synchronization is achieved through bit D3 of the Command Register, which is used to enable or disable the 100Hz clock from the counters. A logic "1" allows the counters to function and a logic "0" disables the counters. To accurately set the time, a logic "0" should be written into D3 and then the desired times entered into the appropriate counters. The clock is then started at the proper time by writing a logic "1" into D3 of the Command Register.

Latched Data

To prevent ambiguity while the processor is gathering data from the registers, the ICM7170 incorporates data latches and a transparent transition delay circuit.

By accessing the 100ths of seconds counter an internal store signal is generated and data from all the counters is transferred into a 36-bit latch. A transition delay circuit will delay a 100Hz transition during a READ cycle. The data stored by the latches is then available for further processing until the 100ths of seconds counter is read again. If a RD signal is wider than 0.01s, 100Hz counts will be ignored.

Control Lines

The RD, WR, and CS signals are active low inputs. Data is placed on the bus from counters or registers when RD is a logic "0". Data is transferred to counters or registers when WR is a logic "0". RD and WR must be accompanied by a logical "0" CS as shown in Figures 2 and 3. The ICM7170 will also work satisfactorily with CS grounded. In this mode, access to the ICM7170 is controlled by RD and WR only.

With the ALE (Address Latch Enable) input, the ICM7170 can be interfaced directly to microprocessors that use a multiplexed address/data bus by connecting the address lines A0 - A4 to the data lines D0 - D4. To address the chip, the address is placed on the bus and ALE is strobed. On the

falling edge, the address and CS information is read into the address latch and buffer. RD and WR are used in the same way as on a non-multiplexed bus. If a non-multiplexed bus is used, ALE should be connected to VDD.

Test Mode

The test mode is entered by setting D5 of the Command Register to a logic "1". This connects the 100Hz counter directly to the oscillator's output.

Oscillator Considerations

Load Design: A new oscillator load configuration, shown in Figure 7, has been found that eliminates start-up problems sometimes encountered with 32kHz tuning fork crystals.

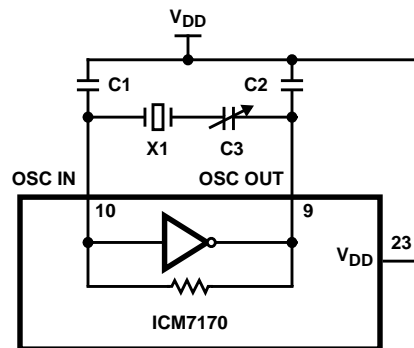

FIGURE 7. NEW OSCILLATOR CONFIGURATION

Two conditions must be met for best oscillator performance: the capacitive load must be matched to both the inverter and crystal to provide the ideal conditions for oscillation, and the resonant frequency of the oscillator must be adjustable to the desired frequency. In the original design (Figure 8), these two goals were often at odds with each other; either the oscillator was trimmed to frequency by detuning the load circuit, or stability was increased at the expense of absolute frequency accuracy.

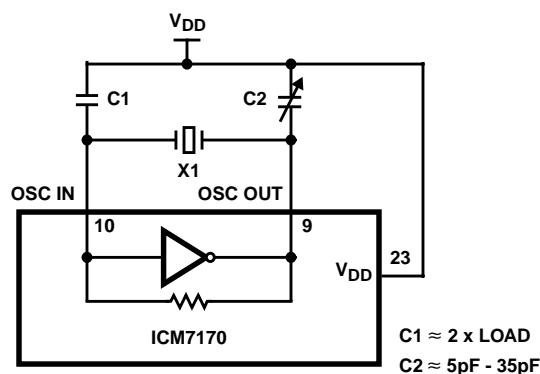

FIGURE 8. ORIGINAL OSCILLATOR CONFIGURATION

The new load configuration (Figure 6) allows these two conditions to be met independently. The two load capacitors, C1 and C2, provide a fixed load to the oscillator and crystal. C3 adjusts the frequency that the circuit resonates at by reducing the effective value of the crystal's motional capacitance, C0. This minute adjustment does not appreciably change the load of the overall system, therefore, stability is no longer affected by tuning. Typical values for these capacitors are shown in Table 5. C1 and C2 must always be greater than twice the crystal's recommended load capacitance in order for C3 to be able to trim the frequency. Some experimentation may be necessary to determine the ideal values of C1 and C2 for a particular crystal.

TABLE 5. TYPICAL LOAD CAPACITOR VALUES

CRYSTAL FREQUENCY	LOAD CAPS (C1, C2)	TRIMMER CAP (C3)
32kHz	33pF	5 - 50pF
1MHz	33pF	5 - 50pF
2MHz	25pF	5 - 50pF
4MHz	22pF	5 - 100pF

This three capacitor tuning method will be more stable than the original design and is mandatory for 32kHz tuning fork crystals: without it they may leap into an overtone mode when power is initially applied.

The original two-capacitor circuit (Figure 8) will continue to work as well as it always has, and may continue to be used in applications where cost or space is a critical consideration. It is also easier to tune to frequency since one end of the trimmer capacitor is fixed at the AC ground of the circuit (V_{DD}), minimizing the disturbance cause by contact between the adjustment tool and the trimmer capacitor. Note that in both configurations the load capacitors are connected between the oscillator pins and V_{DD} - do not use V_{SS} as an AC ground.

Layout: Due to the extremely low current (and therefore high impedance) design of the ICM7170s oscillator, special attention must be given to the layout of this section. Stray capacitance should be minimized. Keep the oscillator traces

on a single layer of the PCB. Avoid putting a ground plane above or below this layer. The traces between the crystal, the capacitors, and the ICM7170 OSC pins should be as short as possible. Completely surround the oscillator components with a thick trace of V_{DD} to minimize coupling with any digital signals. The final assembly must be free from contaminants such as solder flux, moisture, or any other potential sources of leakage. A good solder mask will help keep the traces free of moisture and contamination over time.

Oscillator Tuning

Trimming the oscillator should be done indirectly. Direct monitoring of the oscillator frequency by probing OSC IN or OSC OUT is not accurate due to the capacitive loading of most probes. One way to accurately trim the ICM7170 is by turning on the 1 second periodic interrupt and trimming the oscillator until the interrupt period is exactly one second. This can be done as follows:

1. Turn on the system. Write a 00H to the Interrupt Mask Register (location 10H) to clear all interrupts.
2. Set the Command Register (location 11H) for the appropriate crystal frequency, set the Interrupt Enable and Run/Stop bits to 1, and set the Test bit to 0.
3. Write a 08H to the Interrupt Mask Register to turn on the 1s interrupt.
4. Write an interrupt handler to read the Interrupt Status Register after every interrupt. This resets the interrupt and allows it to be set again. A software loop that reads the Interrupt Status Register several times each second will accomplish this also.
5. Connect a precision period counter capable of measuring 1s within the accuracy desired to the interrupt output. If the interrupt is configured as active low, trigger on the falling edge. If the interrupt is active high, trigger on the rising edge. Be sure to measure the period between when the transistor turns ON, and when the transistor turns ON a second later.
6. Adjust C3 (C2 for the two-capacitor load configuration) for an interrupt period of exactly 1.000000 seconds.

Application Notes

Digital Input Termination During Backup

To ensure low current drain during battery backup operation, none of the digital inputs to the ICM7170 should be allowed to float. This keeps the input logic gates out of their transition region, and prevents crossover current from flowing which will shorten battery life. The address, data, \overline{CS} , and ALE pins should be pulled to either V_{DD} or V_{SS} , and the \overline{RD} and \overline{WR} inputs should be pulled to V_{DD} . This is necessary whether the internal battery switchover circuit is used or not.

IBM/PC Evaluation Circuit

Figure 9 shows the schematic of a board that has been designed to plug into an IBM PC/XT (Note 1) or compatible computer. In this example \overline{CS} is permanently tied low and access to the chip is controlled by the \overline{RD} and \overline{WR} pins. These signals are generated by U1, which gates the IBM's \overline{IOR} and \overline{IOW} with a device select signal from U3, which is

ICM7170

functioning as an I/O block address decoder. DS1 selects the interrupt priority.

U5 is used to isolate the ICM7170 from the PC databus for test purposes. It is only required on heavily-loaded TTL databuses - the ICM7170 can drive most TTL and CMOS databuses directly.

Since the IBM PC/XT (Note 1) requires a positive interrupt transition, the ICM7170's interrupt output transistor has been configured as a source follower. As a source follower, the interrupt output signal will swing between 0V and 2.5V.

When trimming the oscillator, the frequency counter must be triggered on the rising edge of the interrupt signal.

TABLE 6.

BATTERIES	CRYSTALS		
Panasonic	Saronix	32kHz	NTF3238
Rayovac	Statek	32kHz	CX - 1V
	Seiko	2MHz	GT - 38

NOTE:

1. IBM, IBM PC, and IBM XT are trademarks of IBM Corp.

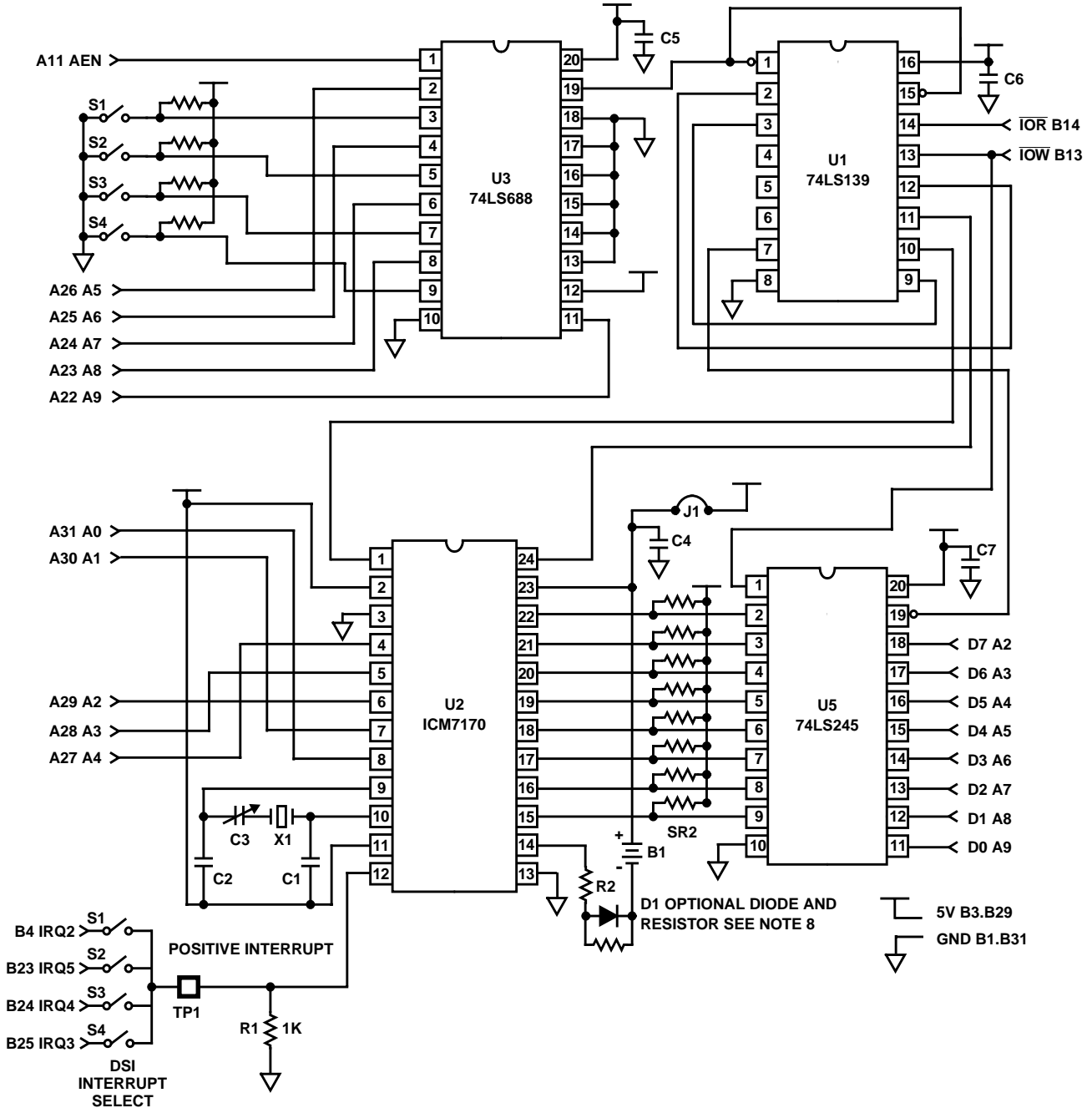

FIGURE 9. IBM PC INTERFACE FOR ICM7170Y

General Notes

1. TIME ACCESS - To update the present time registers (Hex 00 - 07) the $1/100$ register must be read first. The 7 real time counter registers (Hours, Minutes, Seconds, Month, Date, Day, and Year) data are latched only if the $1/100$ second counter register is read. The $1/100$ seconds data itself is not latched. The real time data will be held in the latches until the $1/100$ seconds is read again. See the data sheet section on LATCHED DATA. None of the RAM data is latched since it is static by nature.
2. REGULATED OSCILLATOR - The oscillator's power supply is voltage regulated with respect to V_{DD} . In the 32kHz mode the regulator's amplitude is $\Sigma V_{TN} + V_{TP}$ ($\approx 1.8V$). In the 1, 2, and 4MHz mode the regulator's amplitude is $\Sigma V_{TN} + V_{TN} + V_{TP}$ ($\approx 2.6V$). As a result, signal conditioning is necessary to drive the oscillator with an external signal. In addition, it is also necessary to buffer the oscillator's signal to drive other external clocks because of its reduced amplitude and offset voltage.
3. INTERNAL BATTERY BACKUP - When the ICM7170 is using its own internal battery backup circuitry, no other circuitry interfaced to the ICM7170 should be active during standby operation. When V_{DD} (+5V) is turned off (Standby operation), V_{DD} should equal $V_{SS} = 0V$. All ICM7170 I/O should also equal V_{SS} . At this time, the V_{BACKUP} pin should be 2.8V to 3.5V below V_{SS} when using a Lithium battery.
4. EXTERNAL BATTERY BACKUP - The ICM7170 may be placed on the same power supply as battery-backed up RAM by keeping the ICM7170 in its operational state and having an external circuit switch between system and backup power for the ICM7170 and the RAM. In this case V_{BACKUP} should be pulled up to V_{DD} through a 2K resistor. Although the ICM7170 is always "on" in this configuration, its current consumption will typically be less than a microamp greater than that of standby operation at the same supply voltage (See Note 9). Proper consideration must be given to disabling the ICM7170s and the RAMs I/O before system power is removed. This is important because many microprocessors can generate spurious write signals when their supply falls below their specified operating voltage limits. NANDing \overline{CS} (or \overline{WR}) with a POWERGOOD signal will create a \overline{CS} (or \overline{WR}) that is only valid when system power is within specifications. The POWERGOOD signal should be generated by an accurate supply monitor such as the ICL7665 under/over voltage detector. An alternate method of disabling the ICM7170's I/O is to pull V_{BACKUP} down to under a volt above V_{SS} ($V_{SS} < V_{BACKUP} < 1.0V$). This will cause the ICM7170 to internally disable all I/O. Do not allow V_{BACKUP} to equal V_{SS} , since this could cause oscillation of the battery backup comparator (See Figure 6). $V_{BACKUP} = V_{SS} + 0.5V$ will disable the I/O and provide enough overdrive for the comparator.
5. ICM7170A PART - The ICM7170A part is binned at final test for a 32.768kHz maximum current of $5\mu A$. All other specifications remain the same.
6. INTERRUPTS - The Interrupt Status Register (address 10H) always indicates which of the real time counters have been incremented since the last time the register was read. NOTE: This is independent of whether or not any mask bits are set. The status register is always reset immediately after it is read. If an interrupt from the ICM7170 has occurred since the last time the status register was read, bit D7 of the register will be set. If the source was an alarm interrupt, bit D0 will also be set. If the interrupt transistor has been turned on, reading the Interrupt Status Register will reset it.

To enable the periodic interrupt, both the Command Register's Interrupt Enable bit (D4) and at least one bit in the Interrupt Mask Register (D1 - D6) must be set to a 1. The periodic interrupt is triggered when the counter corresponding to a mask bit that has been set is incremented. For example, if you enable the 1 second interrupt when the current value in the 100ths counter is 57, the first interrupt will occur 0.43 seconds later. All subsequent interrupts will be exactly one second apart. The interrupt service routine should then read the Interrupt Status Register to reset the interrupt transistor and, if necessary, determine the cause of the interrupt (periodic, alarm, or non-ICM7170 generated) from the contents of the status register.

To enable the alarm interrupts, both the Command Register's Interrupt Enable bit (D4) and the Interrupt Mask Register's Alarm bit (D0) must be set to a 1. Each time there is an exact match between the values in the alarm register and the values in the real time counters, bits D0 and D7 of the Interrupt Status Register will be set to a 1 and the N-channel interrupt transistor will be turned on. As with a periodic interrupt, the service routine should then read the Interrupt Status Register to reset the interrupt transistor and, since periodic and alarm interrupts may be simultaneously enabled, determine the cause of the interrupt if necessary.

Mask bits: The ICM7170 alarm interrupt compares the data in the alarm registers with the data in the real time registers, ignoring any registers with the mask bit set. For example, if the alarm register is set to 11-23-95 (Month-Day-Year), 10:59:00:00 (Hour-Minutes-Seconds-Hundredths), and DAY = XX (XX = masked off), the alarm will generate a single interrupt at 10:59 on November 23, 1995. If the alarm register is set to 11-XX-95, 10:XX:00:00, and DAY = 2 (2 = Tuesday); the alarm will generate one interrupt every minute from 10:00-10:59 on every Tuesday in November, 1995.

NOTE: Masking off the 100ths of a second counter has the same effect as setting it to 00.

7. RESISTOR IN SERIES WITH BATTERY - A 2K resistor (R2) must be placed in series with the battery backup pin of the ICM7170. The UL laboratories have requested the resistor to limit the charging and discharging current to the battery. The resistor also serves the purpose of degenerating parasitic SCR action. This SCR action may occur if an input is applied to the ICM7170, outside of its supply voltage range, while it is in the standby mode.
8. V_{BACKUP} DIODE - Lithium batteries may explode if charged or if discharged at too high a rate. These conditions could occur if the battery was installed backwards or in the case of a gross component failure. A 1N914-type diode placed in series with the battery as shown in Figure 9 will prevent this from occurring. A resistor of $2M\Omega$ or so should parallel the diode to keep the V_{BACKUP} terminal from drifting toward the V_{SS} terminal and shutting off ICM7170 I/O during normal operation.
9. SUPPLY CURRENT - ICM7170 supply current is predominantly a function of oscillator frequency and databus activity. The lower the oscillator frequency, the lower the supply current. When there is little or no activity on the data, address or control lines, the current consumption of the ICM7170 in its operational mode approaches that of the backup mode.

Ceramic Dual-In-Line Metal Seal Packages (SBDIP)

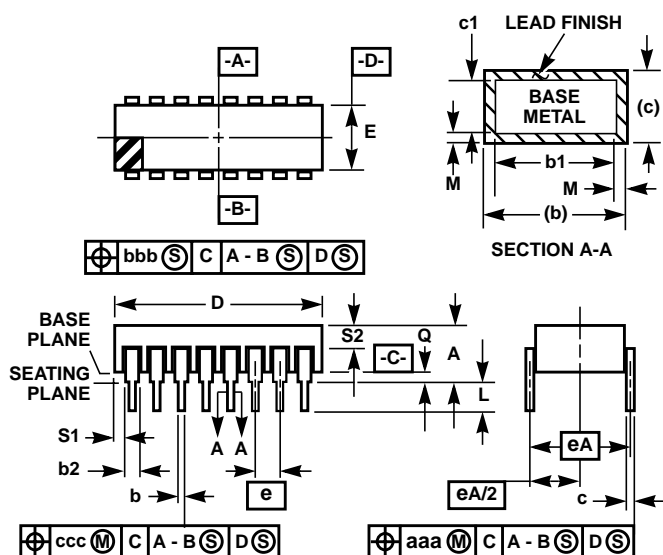

**D24.6 MIL-STD-1835 CDIP2-T24 (D-3, CONFIGURATION C)
24 LEAD CERAMIC DUAL-IN-LINE METAL SEAL PACKAGE**

SYMBOL	INCHES		MILLIMETERS		NOTES
	MIN	MAX	MIN	MAX	
A	-	0.225	-	5.72	-
b	0.014	0.026	0.36	0.66	2
b1	0.014	0.023	0.36	0.58	3
b2	0.045	0.065	1.14	1.65	-
b3	0.023	0.045	0.58	1.14	4
c	0.008	0.018	0.20	0.46	2
c1	0.008	0.015	0.20	0.38	3
D	-	1.290	-	32.77	-
E	0.500	0.610	12.70	15.49	-
e	0.100 BSC		2.54 BSC		-
eA	0.600 BSC		15.24 BSC		-
eA/2	0.300 BSC		7.62 BSC		-
L	0.120	0.200	3.05	5.08	-
Q	0.015	0.075	0.38	1.91	5
S1	0.005	-	0.13	-	6
S2	0.005	-	0.13	-	7
α	90°	105°	90°	105°	-
aaa	-	0.015	-	0.38	-
bbb	-	0.030	-	0.76	-
ccc	-	0.010	-	0.25	-
M	-	0.0015	-	0.038	2
N	24		24		8

NOTES:

1. Index area: A notch or a pin one identification mark shall be located adjacent to pin one and shall be located within the shaded area shown. The manufacturer's identification shall not be used as a pin one identification mark.
2. The maximum limits of lead dimensions b and c or M shall be measured at the centroid of the finished lead surfaces, when solder dip or tin plate lead finish is applied.
3. Dimensions b1 and c1 apply to lead base metal only. Dimension M applies to lead plating and finish thickness.
4. Corner leads (1, N, N/2, and N/2+1) may be configured with a partial lead paddle. For this configuration dimension b3 replaces dimension b2.
5. Dimension Q shall be measured from the seating plane to the base plane.
6. Measure dimension S1 at all four corners.
7. Measure dimension S2 from the top of the ceramic body to the nearest metallization or lead.
8. N is the maximum number of terminal positions.
9. Braze fillets shall be concave.
10. Dimensioning and tolerancing per ANSI Y14.5M - 1982.
11. Controlling dimension: INCH.

Rev. 0 4/94

Dual-In-Line Plastic Packages (PDIP)

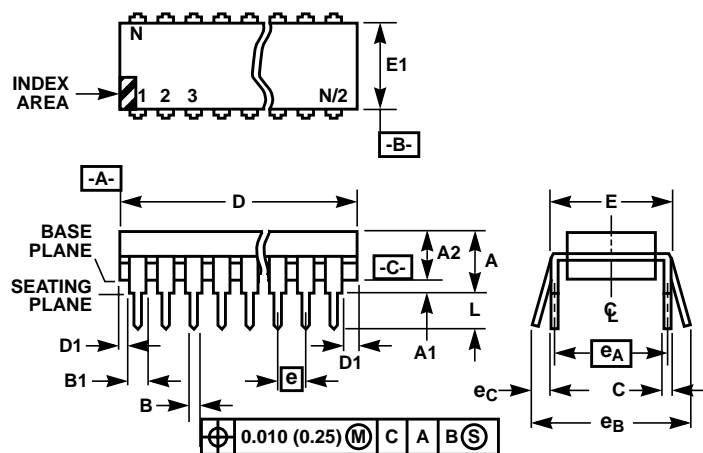

NOTES:

- Controlling Dimensions: INCH. In case of conflict between English and Metric dimensions, the inch dimensions control.
- Dimensioning and tolerancing per ANSI Y14.5M-1982.
- Symbols are defined in the "MO Series Symbol List" in Section 2.2 of Publication No. 95.
- Dimensions A, A1 and L are measured with the package seated in JEDEC seating plane gauge GS-3.
- D, D1, and E1 dimensions do not include mold flash or protrusions. Mold flash or protrusions shall not exceed 0.010 inch (0.25mm).
- E and e_A are measured with the leads constrained to be perpendicular to datum $-C-$.
- e_B and e_C are measured at the lead tips with the leads unconstrained. e_C must be zero or greater.
- B1 maximum dimensions do not include dambar protrusions. Dambar protrusions shall not exceed 0.010 inch (0.25mm).
- N is the maximum number of terminal positions.
- Corner leads (1, N, N/2 and N/2 + 1) for E8.3, E16.3, E18.3, E28.3, E42.6 will have a B1 dimension of 0.030 - 0.045 inch (0.76 - 1.14mm).

E24.6 (JEDEC MS-011-AA ISSUE B)
24 LEAD DUAL-IN-LINE PLASTIC PACKAGE

SYMBOL	INCHES		MILLIMETERS		NOTES
	MIN	MAX	MIN	MAX	
A	-	0.250	-	6.35	4
A1	0.015	-	0.39	-	4
A2	0.125	0.195	3.18	4.95	-
B	0.014	0.022	0.356	0.558	-
B1	0.030	0.070	0.77	1.77	8
C	0.008	0.015	0.204	0.381	-
D	1.150	1.290	29.3	32.7	5
D1	0.005	-	0.13	-	5
E	0.600	0.625	15.24	15.87	6
E1	0.485	0.580	12.32	14.73	5
e	0.100 BSC		2.54 BSC		-
e_A	0.600 BSC		15.24 BSC		6
e_B	-	0.700	-	17.78	7
L	0.115	0.200	2.93	5.08	4
N	24		24		9

Rev. 0 12/93

Small Outline Plastic Packages (SOIC)

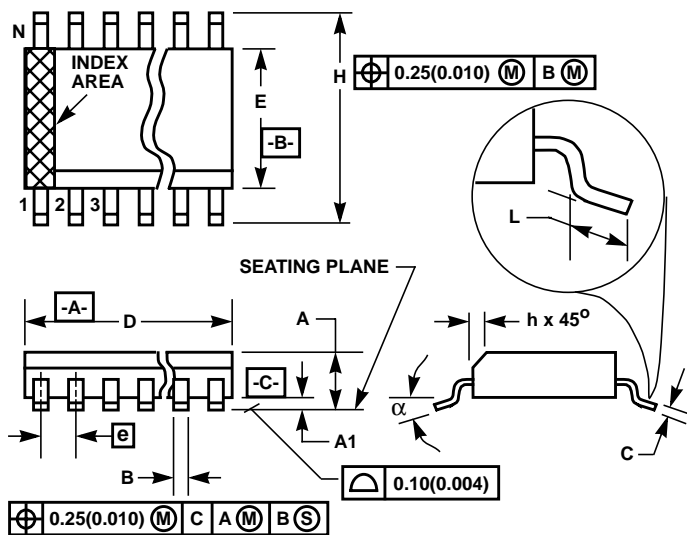

**M24.3 (JEDEC MS-013-AD ISSUE C)
24 LEAD WIDE BODY SMALL OUTLINE PLASTIC PACKAGE**

SYMBOL	INCHES		MILLIMETERS		NOTES
	MIN	MAX	MIN	MAX	
A	0.0926	0.1043	2.35	2.65	-
A1	0.0040	0.0118	0.10	0.30	-
B	0.013	0.020	0.33	0.51	9
C	0.0091	0.0125	0.23	0.32	-
D	0.5985	0.6141	15.20	15.60	3
E	0.2914	0.2992	7.40	7.60	4
e	0.05 BSC		1.27 BSC		-
H	0.394	0.419	10.00	10.65	-
h	0.010	0.029	0.25	0.75	5
L	0.016	0.050	0.40	1.27	6
N	24		24		7
alpha	0°	8°	0°	8°	-

NOTES:

1. Symbols are defined in the "MO Series Symbol List" in Section 2.2 of Publication Number 95.
2. Dimensioning and tolerancing per ANSI Y14.5M-1982.
3. Dimension "D" does not include mold flash, protrusions or gate burrs. Mold flash, protrusion and gate burrs shall not exceed 0.15mm (0.006 inch) per side.
4. Dimension "E" does not include interlead flash or protrusions. Interlead flash and protrusions shall not exceed 0.25mm (0.010 inch) per side.
5. The chamfer on the body is optional. If it is not present, a visual index feature must be located within the crosshatched area.
6. "L" is the length of terminal for soldering to a substrate.
7. "N" is the number of terminal positions.
8. Terminal numbers are shown for reference only.
9. The lead width "B", as measured 0.36mm (0.014 inch) or greater above the seating plane, shall not exceed a maximum value of 0.61mm (0.024 inch)
10. Controlling dimension: MILLIMETER. Converted inch dimensions are not necessarily exact.

Rev. 0 12/93

All Intersil semiconductor products are manufactured, assembled and tested under **ISO9000** quality systems certification.

Intersil semiconductor products are sold by description only. Intersil Corporation reserves the right to make changes in circuit design and/or specifications at any time without notice. Accordingly, the reader is cautioned to verify that data sheets are current before placing orders. Information furnished by Intersil is believed to be accurate and reliable. However, no responsibility is assumed by Intersil or its subsidiaries for its use; nor for any infringements of patents or other rights of third parties which may result from its use. No license is granted by implication or otherwise under any patent or patent rights of Intersil or its subsidiaries.

For information regarding Intersil Corporation and its products, see web site www.intersil.com

Sales Office Headquarters

NORTH AMERICA
Intersil Corporation
P. O. Box 883, Mail Stop 53-204
Melbourne, FL 32902
TEL: (321) 724-7000
FAX: (321) 724-7240

EUROPE
Intersil SA
Mercure Center
100, Rue de la Fusee
1130 Brussels, Belgium
TEL: (32) 2.724.2111
FAX: (32) 2.724.22.05

ASIA
Intersil Ltd.
8F-2, 96, Sec. 1, Chien-kuo North,
Taipei, Taiwan 104
Republic of China
TEL: 886-2-2515-8508
FAX: 886-2-2515-8369