

November 1996

Automatic Picture Tube Bias Control Circuit

Features

- Automatic Picture Tube Bias Cutoff Control
- Automatic Background Color Balance
- Eliminates Grey Scale Adjustments
- Compensates for Cathode-to-Heater Leakage
- Electrostatic Protection on All Pins
- Servo Loop Design
- Wide Dynamic Range
- Three-Gun Control
- Minimal External Components

Ordering Information

PART NUMBER	TEMP. RANGE (°C)	PACKAGE	PKG. NO.
CA3224E	-40 to 85	22 Ld PDIP	E22.4

Description

The CA3224E is an automatic picture tube bias control circuit used in color TV receiver CRT drive circuits. It is used to provide dynamic bias control of the grey scale both initially and over the CRT operating life, compensating for CRT cut-off changes.

The CA3224E provides automatic continuous control of the cutoff current in each gun of a three-gun color CRT. From an input pulse amplitude proportional to the difference between the desired and the actual CRT cutoff, a gated sample/hold circuit generates a DC correction voltage which correctly biases the CRT driver circuit. The sample/hold bias correction takes place each frame following the vertical blanking. Figure 1 shows a block diagram of the CA3224E. The functions include three identical servo loop transconductance amplifiers with a sample/hold switch and buffer amplifier plus control logic, internal bias and a mode switch.

Pinout

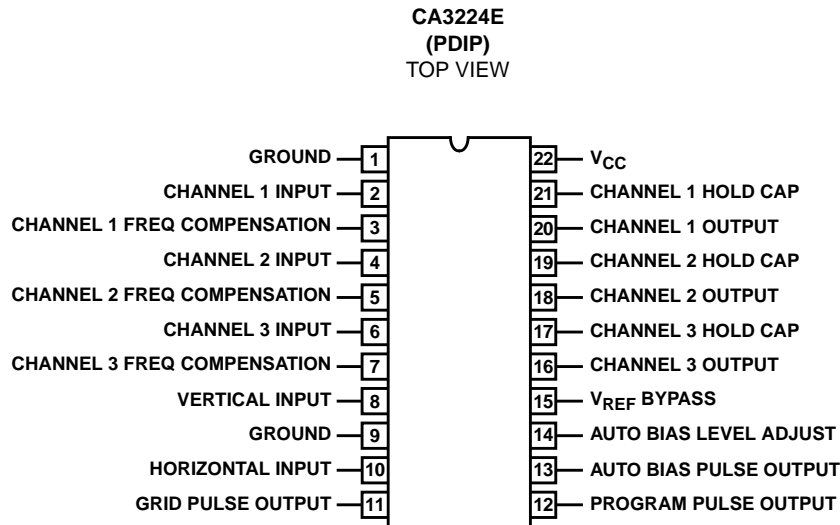

CA3224E

Absolute Maximum Ratings $T_A = 25^\circ\text{C}$

Supply Voltage (V_{CC}) 11V
 DC Input Voltage -1 to V_{CC}
 Output Current Short Circuit Protected

Thermal Information

Thermal Resistance (Typical, Note 1) θ_{JA} ($^\circ\text{C}/\text{W}$)
 PDIP Package 77
 Maximum Junction Temperature (Plastic Package) 150°C
 Maximum Storage Temperature Range -65°C to 150°C
 Maximum Lead Temperature (Soldering 10s) 300°C

Operating Conditions

Temperature Range -40°C to 85°C
 Supply Voltage Range (Typical) $10\text{V} \pm 10\%$

CAUTION: Stresses above those listed in "Absolute Maximum Ratings" may cause permanent damage to the device. This is a stress only rating and operation of the device at these or any other conditions above those indicated in the operational sections of this specification is not implied.

NOTE:

- θ_{JA} is measured with the component mounted on an evaluation PC board in free air.

Electrical Specifications At $T_A = 25^\circ\text{C}$, $V_{CC} = 10\text{V}$, $V_{BIAS} = 3.75\text{V}$, V_V (Pin 8) = V_H (Pin 10) = 6.0V , $S_1 = A$, $S_2 = A$, See Test Circuit and Timing Diagrams

PARAMETER		TEST PIN NO.	SYMBOL	TEST CONDITIONS	MIN	TYP	MAX	UNITS
Supply Current		22	I_{CC}		-	-	65	mA
Reference Voltage		2, 4, 6	V_{REF}	Measure at t_4	5.6	6.0	6.4	V
Input Current		2, 4, 6	I_I	$V_{IN} = 7.2\text{V}$, $S_1 = B$	-	-	250	nA
Output Current	Source	17,19, 21	I_{OM+}	$V_{BIAS} = 0.5\text{V}$, Measure at t_6 , $S_1 = B$	-	-	-0.8	mA
	Sink		I_{OM-}	$V_{BIAS} = 7.0\text{V}$, Measure at t_6 , $S_1 = B$	0.8	-	-	mA
Output Buffer	Input Current	17,19, 21	I_I	$V_{OUT} = 6.5\text{V}$, V_{IN} At pins 16, 18, 20, Measure at t_4 , $S_1 = B$	-	-	150	nA
	Voltage Gain		A_V		0.97	-	1.07	-
Transconductance		17,19, 21	g_M	Measure at t_6 , $V_{IN} = 8\text{mV}_{P-P}$ at 40kHz, $S_1 = B$	50	-	100	mS
Auto Bias Pulse	Output Low	13	V_{OL}	Measure at t_1	-	-	0.3	V
	High		V_{OH}	Measure at t_4	6.05	-	-	V
	Current Sink		I_{OM-}	Measure at t_4 , $S_2 = B$	2.5	-	-	mA
Grid Pulse Output	Low	11	V_{OL}	Measure at t_4	-	-	0.4	V
	High		V_{OH}	Measure at t_1	4.2	-	-	V
Program Pulse Output	Low	12	V_{OL}	Measure at t_6	-	-	0.4	V
	High		V_{OH}	Measure at t_1	8.2	-	-	V
Vertical Input		8	V_V	See Figure 3	-	6.0	-	V
Horizontal Input		10	V_H	See Figure 3	-	6.0	-	V
Auto Bias Pulse Timing	Start	13		t_0 to t_2 , Note 2	835	-	842	μs
	Finish			t_0 to t_7 , Note 2	1270	-	1275	μs
Grid Pulse Timing	Start	11		t_0 to t_3 , Note 2	899	-	905	μs
	Finish			t_0 to t_5 , Note 2	1080	-	1084	μs
Program Pulse Timing	Start	12		t_0 to t_5 , Note 2	1080	-	1084	μs
	Finish			t_0 to t_7 , Note 2	1270	-	1275	μs

NOTE:

- All time measurements are made from 50% point to 50% point.

Test Circuit

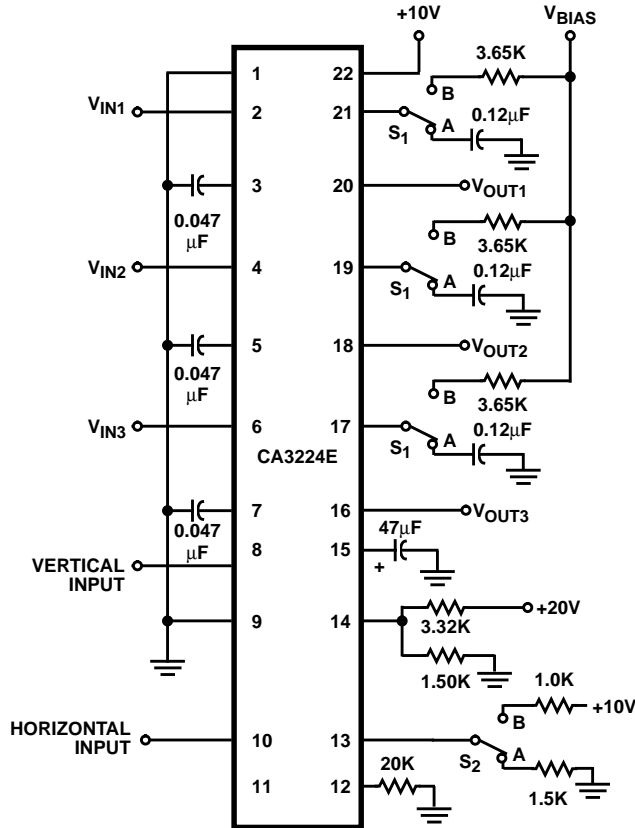

Device Description and Operation

(See Figures 1, 2, 4 and 5)

During the vertical retrace interval, 13 horizontal sync pulses are counted. On the 14th sync pulse the auto-bias pulse output goes high. This is used to set the RGB drive of the companion chroma/luma circuit to black level. The auto-bias pulse stays high for 7 horizontal periods during the auto-bias cycle.

On the 15th horizontal sync pulse, the internal logic initiates the setup interval. During the setup interval, the cathode current is increased to a reference value (A in Figure 5) through the action of the grid pulse. The cathode current causes a voltage drop across R_S . This voltage drop, together with the program pulse output results in a reference voltage at V_S (summing point) which causes capacitor C_1 to charge to a voltage proportional to the reference cathode current. The setup interval lasts for 3 horizontal periods.

On the 18th horizontal sync pulse the grid pulse output goes high, which through the grid pulse amplifier/inverter, causes the cathode current to decrease. The decrease in cathode current results in a positive recovered voltage pulse with respect to the setup reference level at the V_S summing point. The positive recovered voltage pulse is summed with a negative voltage pulse caused by the program pulse output going low (cutting off Diode D_1 and switching in resistors R_1 and R_2). Any difference between the positive and negative pulses is fed through capacitor C_1 to the transconductance amplifier. The difference signal is amplified in the transconductance amplifier and charges the hold capacitor C_2 , which, through the buffer amplifier, adjusts the bias on the driver circuit.

Components R_S , R_1 , and R_2 must be chosen such that the program pulse and the recovered pulse just cancel at the desired cathode cutoff level.

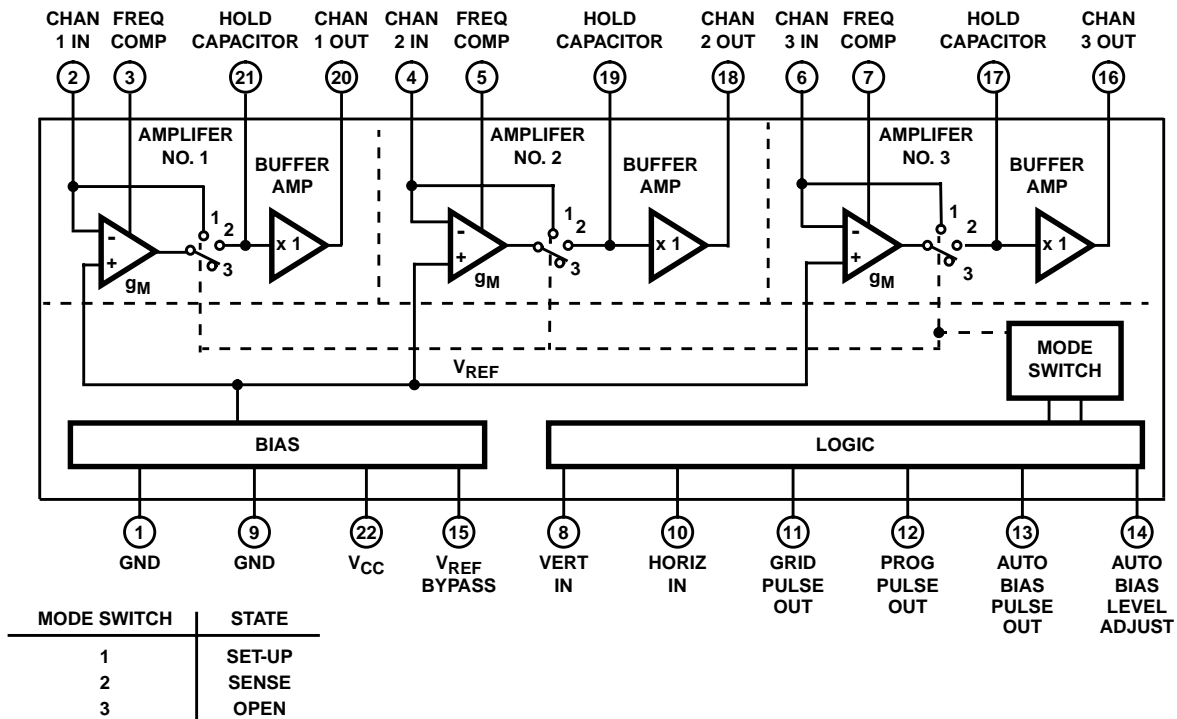

FIGURE 1. FUNCTIONAL BLOCK DIAGRAM

CA3224E

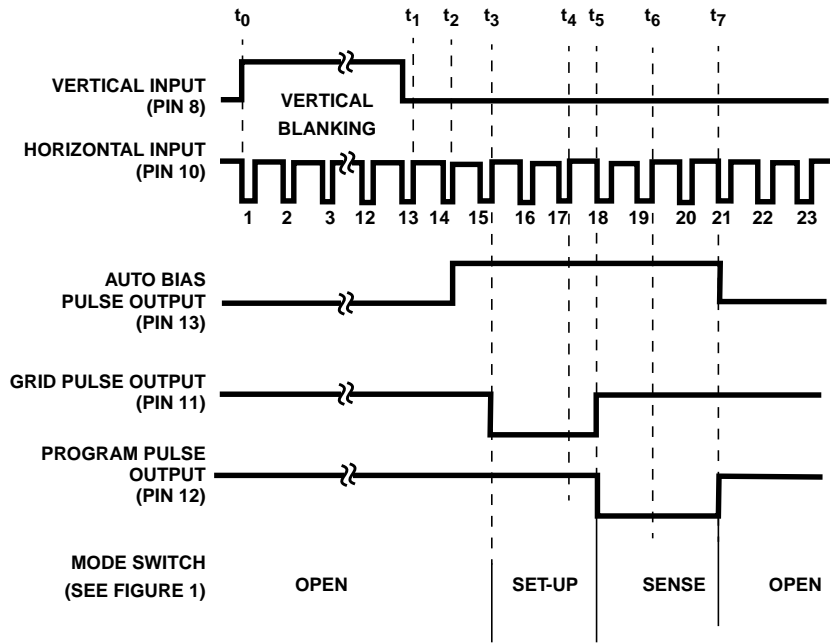

FIGURE 2. FUNCTIONAL TIMING DIAGRAMS

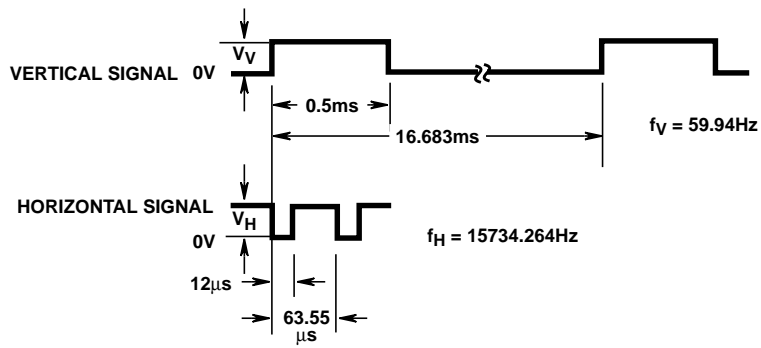
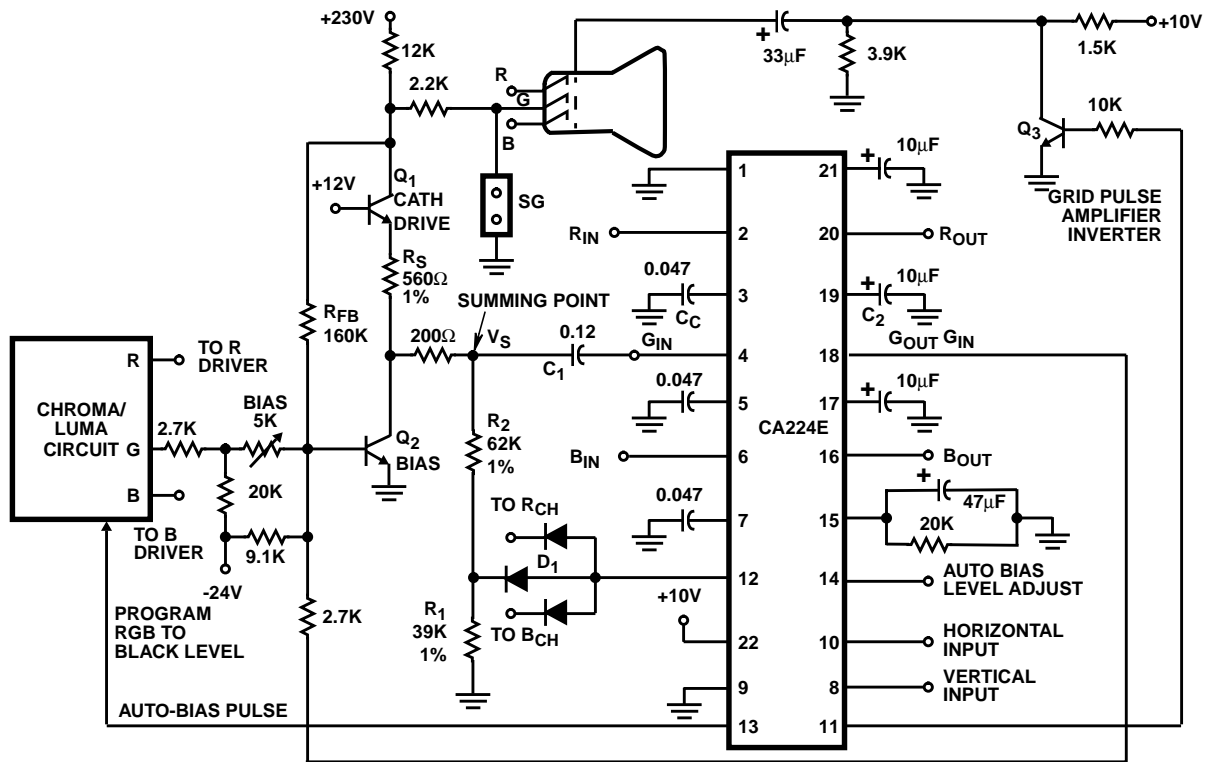

FIGURE 3. VERTICAL AND HORIZONTAL INPUT SIGNALS

CA3224E



NOTE:

3. One of three identical driver circuits shown.

FIGURE 4. TYPICAL APPLICATION CIRCUIT

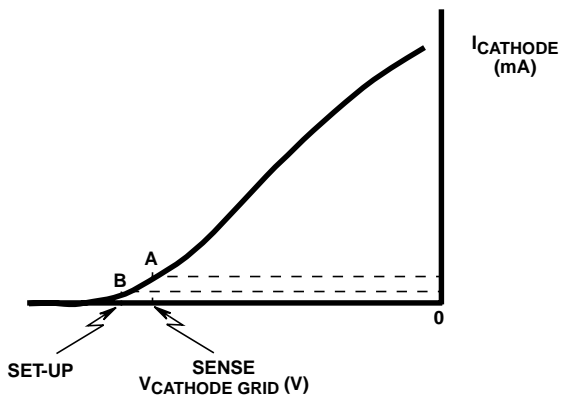

FIGURE 5. PICTURE TUBE V-I CURVE

Electrostatic Protection (Note)

When correctly designed for ESD protection, SCRs can be highly effective, enabling circuits to be protected to well in excess of 4kV. The SCR ESD-EOS protection structures used on each terminal of the CA3224E are shown schematically in either Figures 6A or 6B. Although ESD-EOS protection is included in the CA3224E, proper circuit board layout and grounding techniques should be observed.

NOTE: For further information on CA3224E protection structures refer to: AN7304, "Using SCRs as Transient Protection Structures in Integrated Circuits", by L.R. Avery. Intersil AnswerFAX (407-724-7800) document #97304.

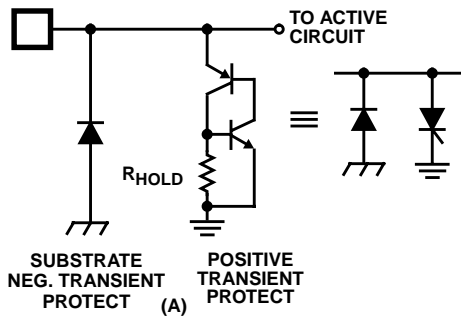

FIGURE 6A.

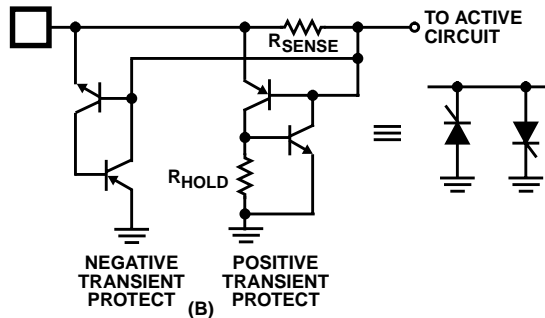

FIGURE 6B.

FIGURE 6. TRANSIENT PROTECTION

All Intersil semiconductor products are manufactured, assembled and tested under **ISO9000** quality systems certification.

Intersil products are sold by description only. Intersil Corporation reserves the right to make changes in circuit design and/or specifications at any time without notice. Accordingly, the reader is cautioned to verify that data sheets are current before placing orders. Information furnished by Intersil is believed to be accurate and reliable. However, no responsibility is assumed by Intersil or its subsidiaries for its use; nor for any infringements of patents or other rights of third parties which may result from its use. No license is granted by implication or otherwise under any patent or patent rights of Intersil or its subsidiaries.

For information regarding Intersil Corporation and its products, see web site <http://www.intersil.com>

Sales Office Headquarters

NORTH AMERICA

Intersil Corporation
P. O. Box 883, Mail Stop 53-204
Melbourne, FL 32902
TEL: (321) 724-7000
FAX: (321) 724-7240

EUROPE

Intersil SA
Mercure Center
100, Rue de la Fusee
1130 Brussels, Belgium
TEL: (32) 2.724.2111
FAX: (32) 2.724.22.05

ASIA

Intersil (Taiwan) Ltd.
Taiwan Limited
7F-6, No. 101 Fu Hsing North Road
Taipei, Taiwan
Republic of China
TEL: (886) 2 2716 9310
FAX: (886) 2 2715 3029