

# HUF75343G3, HUF75343P3, HUF75343S3, HUF75343S3S

75A, 55V, 0.009 Ohm, N-Channel  
**UltraFET™ Power MOSFETs**

August 1997

## Features

- 75A, 55V
- **Ultra Low On-Resistance**,  $r_{DS(ON)} = 0.009\Omega$
- **Diode Exhibits Both High Speed and Soft Recovery**
- **Temperature Compensating PSPICE Model**
- **Thermal Impedance PSPICE Model**
- **Peak Current vs Pulse Width Curve**
- **UIS Rating Curve**

## Ordering Information

PART NUMBER	PACKAGE	BRAND
HUF75343G3	TO-247	75343G
HUF75343P3	TO-220AB	75343P
HUF75343S3	TO-262AA	75343S
HUF75343S3S	TO-263AB	75343S

NOTE: When ordering, use the entire part number. Add the suffix T to obtain the TO-263AB variant in tape and reel, i.e., HUF75343S3ST.

## Description

The HUF75343 N-Channel power MOSFET is manufactured using the innovative *UltraFET™* process. This advanced process technology achieves the lowest possible on-resistance per silicon area, resulting in outstanding performance. This device is capable of withstanding high energy in the avalanche mode and the diode exhibits very low reverse recovery time and stored charge. It was designed for use in applications where power efficiency is important, such as switching regulators, switching converters, motor drivers, relay drivers, low-voltage bus switches, and power management in portable and battery-operated products.

Formerly developmental type TA75343.

## Symbol

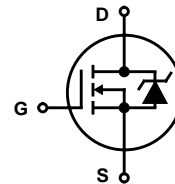

## Packaging

JEDEC TO-247

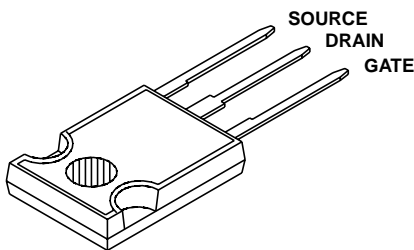

JEDEC TO-262AA

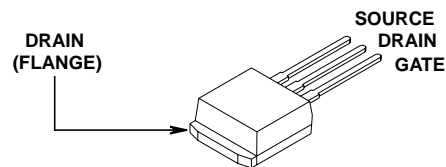

JEDEC TO-220AB

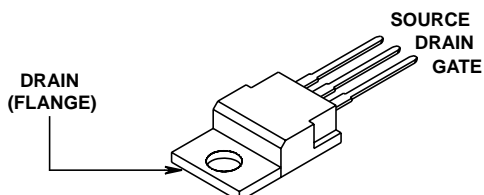

JEDEC TO-263AB

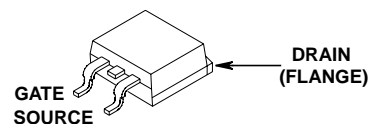

## HUF75343G3, HUF75343P3, HUF75343S3, HUF75343S3S

### Absolute Maximum Ratings $T_C = 25^\circ\text{C}$ , Unless Otherwise Specified

Drain to Source Voltage	$V_{DSS}$	55	V
Drain to Gate Voltage ( $R_{GS} = 20k\Omega$ ) (Note 1)	$V_{DGR}$	55	V
Gate to Source Voltage	$V_{GS}$	$\pm 20$	V
Drain Current			
Continuous (Figure 2)	$I_D$	75	A
Pulsed Drain Current	$I_{DM}$	Figure 5	
Pulsed Avalanche Rating	$E_{AS}$	Figures 12,14,15	
Power Dissipation (Figure 4)	$P_D$	150	W
Derate Above $25^\circ\text{C}$ (Figure 1)		1.0	W/ $^\circ\text{C}$
Operating and Storage Temperature	$T_J, T_{STG}$	-55 to 175	$^\circ\text{C}$
Soldering Temperature of Leads for 10s	$T_L$	260	$^\circ\text{C}$

*CAUTION: Stresses above those listed in "Absolute Maximum Ratings" may cause permanent damage to the device. This is a stress only rating and operation of the device at these or any other conditions above those indicated in the operational sections of this specification is not implied.*

**NOTE:**

- $T_J = 25^\circ\text{C}$  to  $150^\circ\text{C}$ .

### Electrical Specifications $T_C = 25^\circ\text{C}$ , Unless Otherwise Specified

PARAMETERS	SYMBOL	TEST CONDITIONS	MIN	TYP	MAX	UNITS
Drain to Source Breakdown Voltage	$BV_{DSS}$	$I_D = 250\mu\text{A}, V_{GS} = 0\text{V}$ (Figure 10)	55	-	-	V
Gate to Source Threshold Voltage	$V_{GS(TH)}$	$V_{GS} = V_{DS}, I_D = 250\mu\text{A}$ (Figure 9)	2	-	4	V
Zero Gate Voltage Drain Current	$I_{DSS}$	$V_{DS} = 50\text{V}, V_{GS} = 0\text{V}$	-	-	1	$\mu\text{A}$
		$V_{DS} = 45\text{V}, V_{GS} = 0\text{V}, T_C = 150^\circ\text{C}$	-	-	250	$\mu\text{A}$
Gate to Source Leakage Current	$I_{GSS}$	$V_{GS} = \pm 20\text{V}$	-	-	100	nA
Drain to Source On Resistance	$r_{DS(ON)}$	$I_D = 75\text{A}, V_{GS} = 10\text{V}$ (Figure 8)	-	-	0.009	$\Omega$
Turn-On Time	$t_{ON}$	$V_{DD} = 30\text{V}, I_D \cong 75\text{A}, R_L = 0.40\Omega, V_{GS} = 10\text{V}, R_{GS} = 2.5\Omega$ (Figures 18, 19)	-	-	125	ns
Turn-On Delay Time	$t_{d(ON)}$		-	9	-	ns
Rise Time	$t_r$		-	75	-	ns
Turn-Off Delay Time	$t_{d(OFF)}$		-	32	-	ns
Fall Time	$t_f$		-	18	-	ns
Turn-Off Time	$t_{OFF}$		-	-	75	ns
Total Gate Charge	$Q_{g(TOT)}$	$V_{GS} = 0\text{V to } 20\text{V}$	-	170	205	nC
Gate Charge at 10V	$Q_{g(10)}$	$V_{GS} = 0\text{V to } 10\text{V}$				
Threshold Gate Charge	$Q_{g(TH)}$	$V_{GS} = 0\text{V to } 2\text{V}$				
Input Capacitance	$C_{ISS}$	$V_{DS} = 25\text{V}, V_{GS} = 0\text{V}, f = 1\text{MHz}$ (Figure 11)	-	3000	-	pF
Output Capacitance	$C_{OSS}$		-	1100	-	pF
Reverse Transfer Capacitance	$C_{RSS}$		-	230	-	pF
Thermal Resistance Junction to Case	$R_{\theta JC}$	(Figure 3)	-	-	1.0	$^\circ\text{C/W}$
Thermal Resistance Junction to Ambient	$R_{\theta JA}$	TO-247	-	-	30	$^\circ\text{C/W}$
		TO-220, TO-262 and TO-263	-	-	62	$^\circ\text{C/W}$

### Source to Drain Diode Specifications

PARAMETERS	SYMBOL	TEST CONDITIONS	MIN	TYP	MAX	UNITS
Source to Drain Diode Voltage	$V_{SD}$	$I_{SD} = 75\text{A}$	-	-	1.25	V
Reverse Recovery Time	$t_{rr}$	$I_{SD} = 75\text{A}, dI_{SD}/dt = 100\text{A}/\mu\text{s}$	-	-	100	ns
Reverse Recovered Charge	$Q_{RR}$	$I_{SD} = 75\text{A}, dI_{SD}/dt = 100\text{A}/\mu\text{s}$	-	-	200	nC

Typical Performance Curves

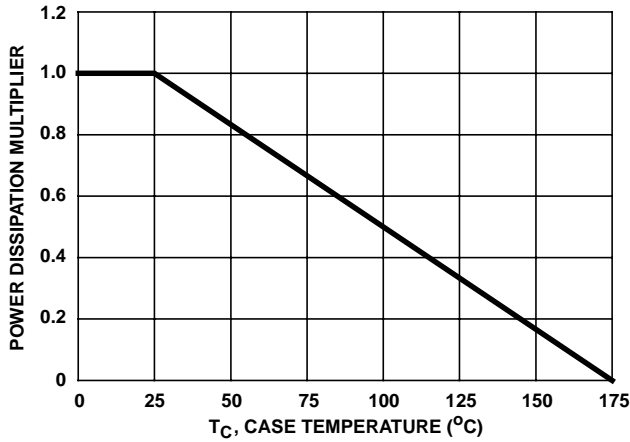

FIGURE 1. NORMALIZED POWER DISSIPATION vs CASE TEMPERATURE

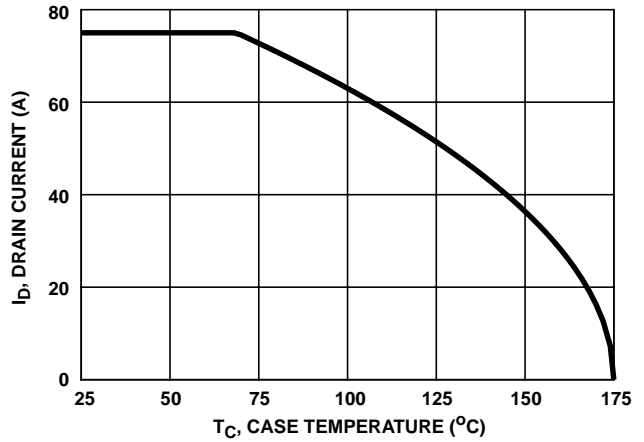

FIGURE 2. MAXIMUM CONTINUOUS DRAIN CURRENT vs CASE TEMPERATURE

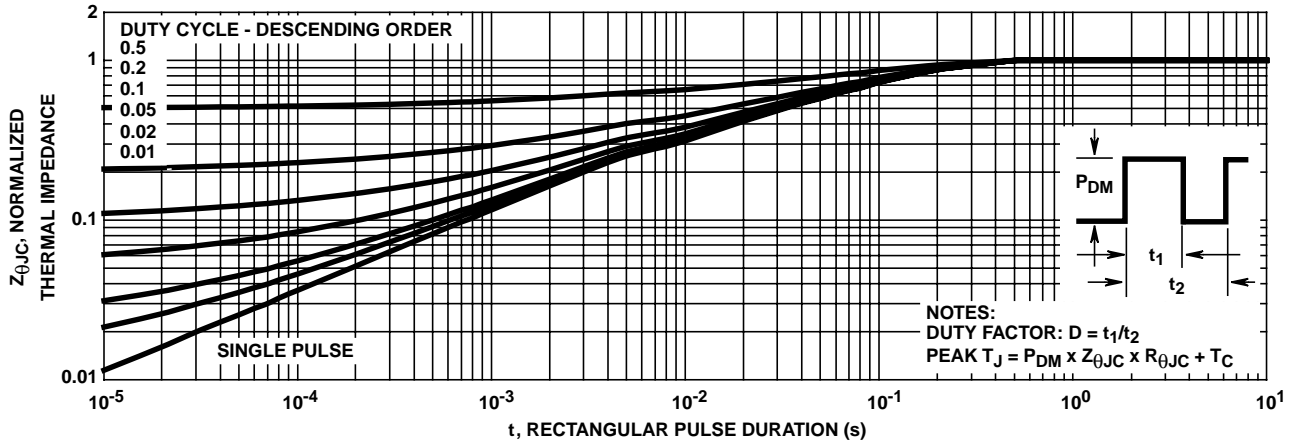

FIGURE 3. NORMALIZED MAXIMUM TRANSIENT THERMAL IMPEDANCE

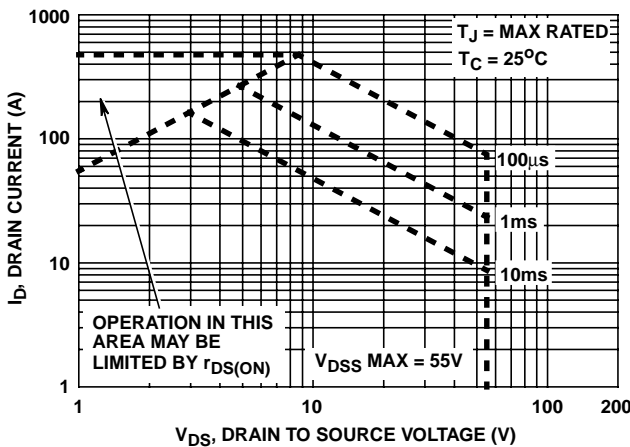

FIGURE 4. FORWARD BIAS SAFE OPERATING AREA

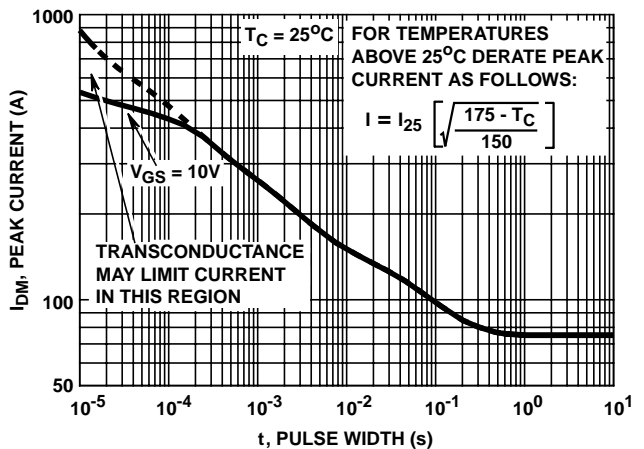

FIGURE 5. PEAK CURRENT CAPABILITY

Typical Performance Curves (Continued)

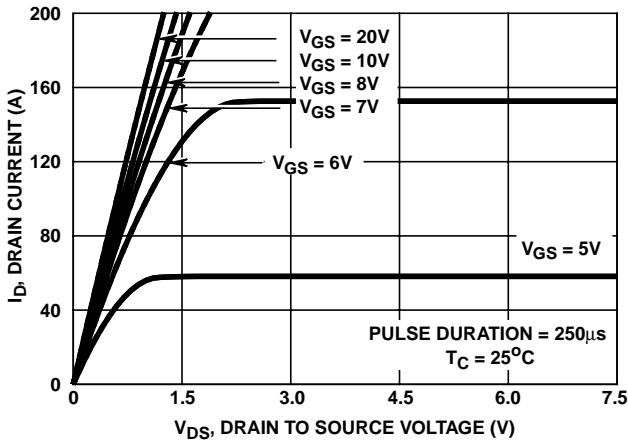

FIGURE 6. SATURATION CHARACTERISTICS

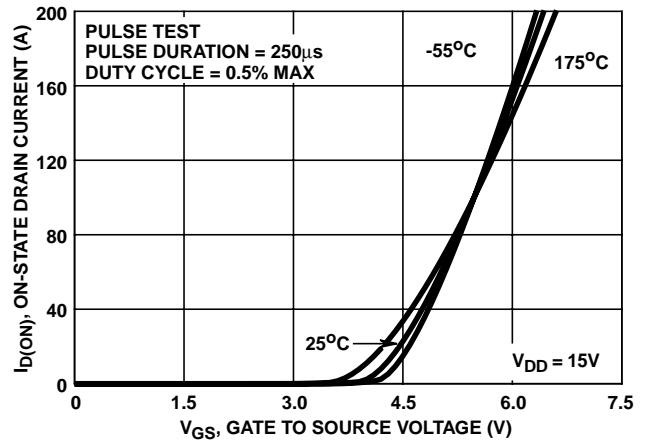

FIGURE 7. TRANSFER CHARACTERISTICS

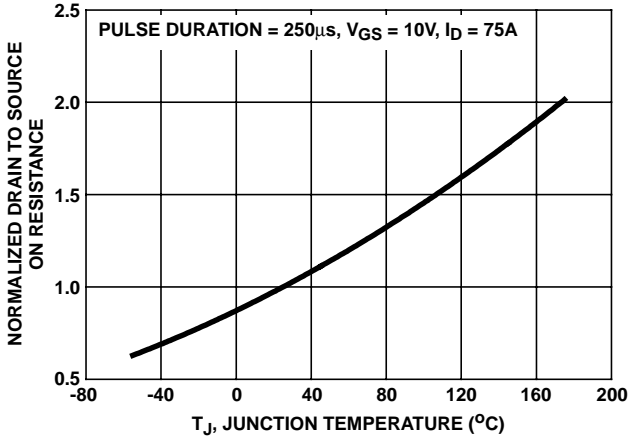

FIGURE 8. NORMALIZED DRAIN TO SOURCE ON RESISTANCE vs JUNCTION TEMPERATURE

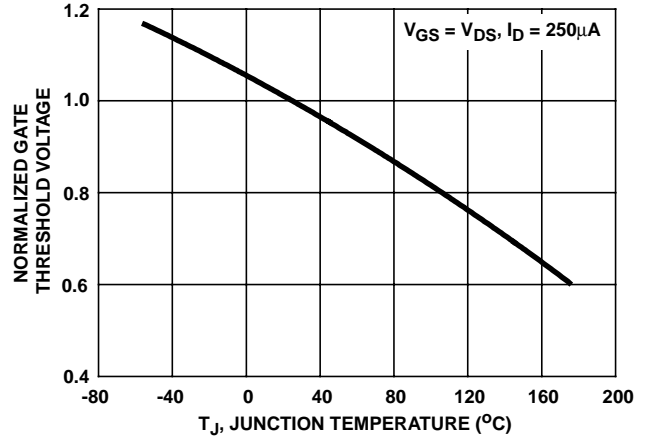

FIGURE 9. NORMALIZED GATE THRESHOLD VOLTAGE vs JUNCTION TEMPERATURE

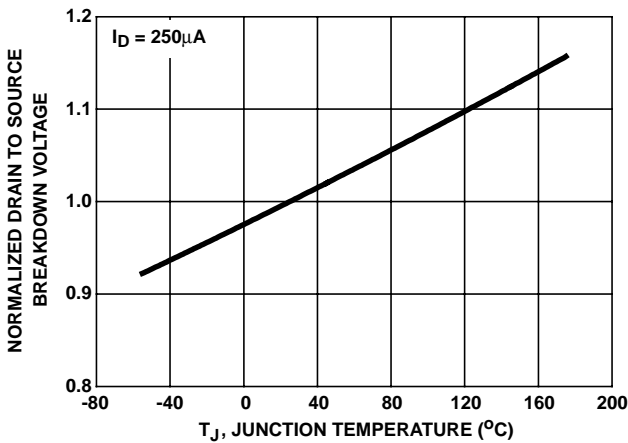

FIGURE 10. NORMALIZED DRAIN TO SOURCE BREAKDOWN VOLTAGE vs JUNCTION TEMPERATURE

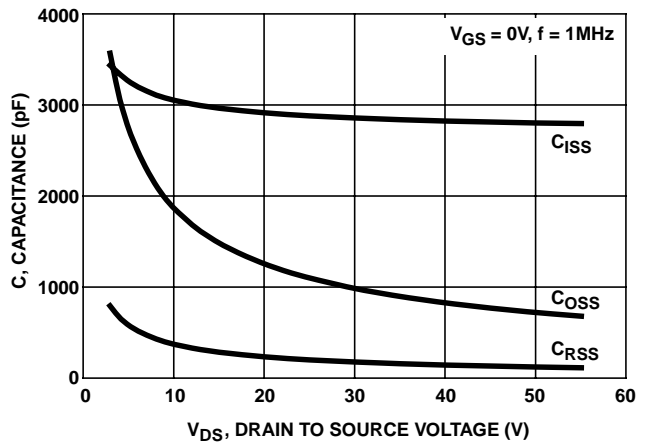
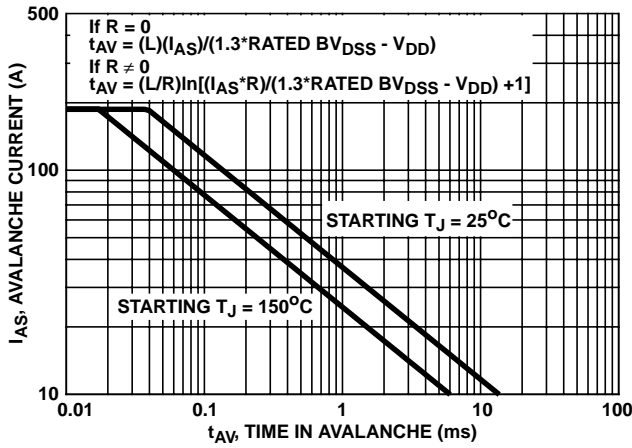

FIGURE 11. CAPACITANCE vs DRAIN TO SOURCE VOLTAGE

Typical Performance Curves (Continued)



NOTE: Refer to Harris Application Notes AN9321 and AN9322.

FIGURE 12. UNCLAMPED INDUCTIVE SWITCHING CAPABILITY

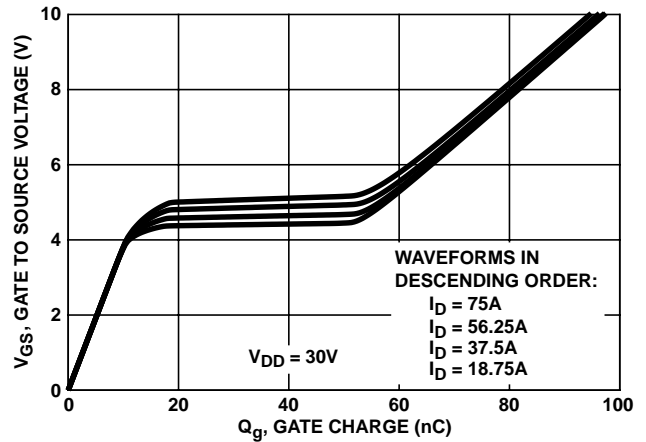

NOTE: Refer to Harris Application Notes AN7254 and AN7260.

FIGURE 13. GATE CHARGE WAVEFORMS FOR CONSTANT GATE CURRENT

Test Circuits and Waveforms

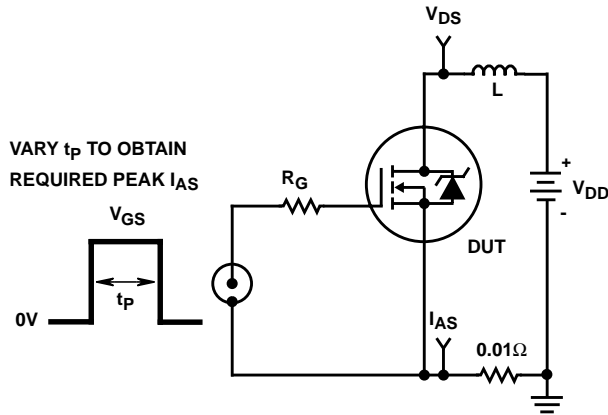

FIGURE 14. UNCLAMPED ENERGY TEST CIRCUIT

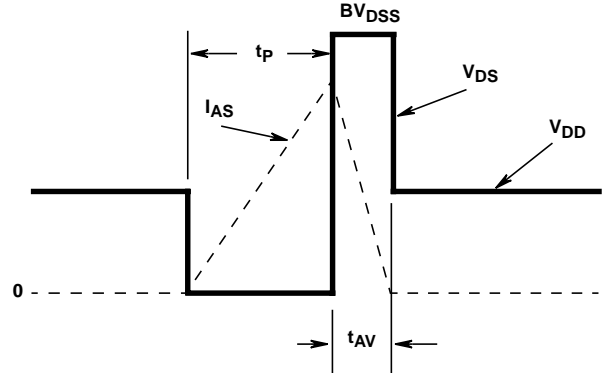

FIGURE 15. UNCLAMPED ENERGY WAVEFORMS

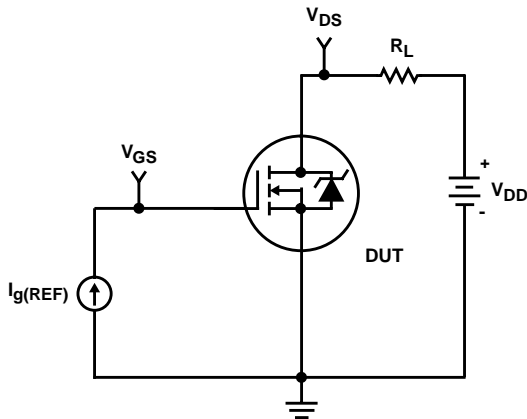

FIGURE 16. GATE CHARGE TEST CIRCUIT

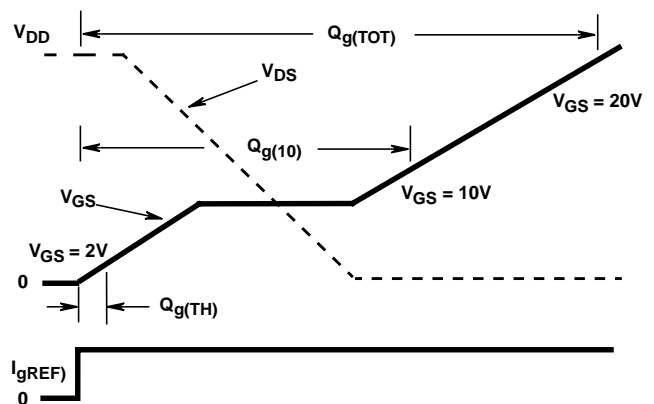

FIGURE 17. GATE CHARGE WAVEFORM

**Test Circuits and Waveforms** (Continued)

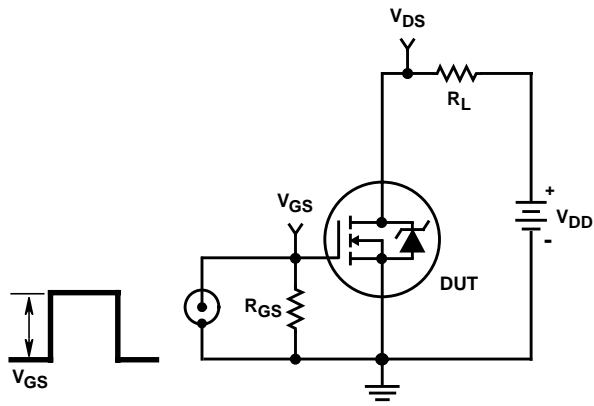

FIGURE 18. SWITCHING TIME TEST CIRCUIT

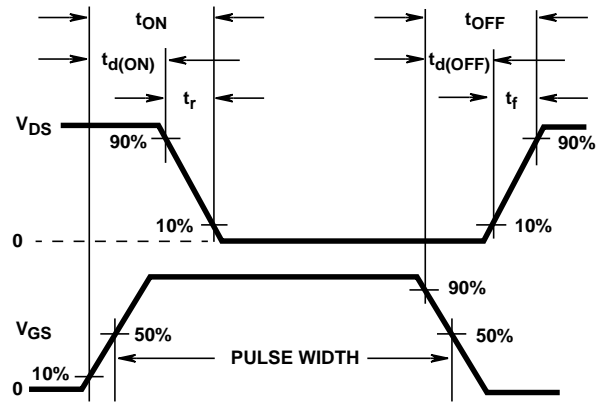

FIGURE 19. RESISTIVE SWITCHING WAVEFORMS

# HUF75343G3, HUF75343P3, HUF75343S3, HUF75343S3S

## PSPICE Electrical Model

SUBCKT HUF75343 2 1 3 ; rev 6/17/97

CA 12 8 3.95e-9  
 CB 15 14 5.05e-9  
 CIN 6 8 2.68e-9

DBODY 7 5 DBODYMOD  
 DBREAK 5 11 DBREAKMOD  
 DPLCAP 10 5 DPLCAPMOD

EBREAK 11 7 17 18 58.39  
 EDS 14 8 5 8 1  
 EGS 13 8 6 8 1  
 ESG 6 10 6 8 1  
 EVTHRES 6 21 19 8 1  
 EVTEMP 20 6 18 22 1

IT 8 17 1

LDRAIN 2 5 1e-9  
 LGATE 1 9 2.6e-9  
 LSOURCE 3 7 1.1e-9  
 K1 LSOURCE LGATE 0.0085

MMED 16 6 8 8 MMEDMOD  
 MSTRO 16 6 8 8 MSTROMOD  
 MWEAK 16 21 8 8 MWEAKMOD

RBREAK 17 18 RBREAKMOD 1  
 RDRAIN 50 16 RDRAINMOD 0.70e-3  
 RGATE 9 20 0.36  
 RLDRAIN 2 5 10  
 RLGATE 1 9 26  
 RLSOURCE 3 7 11  
 RSLC1 5 51 RSLCMOD 1e-6  
 RSLC2 5 50 1e3  
 RSOURCE 8 7 RSOURCEMOD 4.79e-3  
 RVTHRES 22 8 RVTHRESMOD 1  
 RVTEMP 18 19 RVTEMPMOD 1

S1A 6 12 13 8 S1AMOD  
 S1B 13 12 13 8 S1BMOD  
 S2A 6 15 14 13 S2AMOD  
 S2B 13 15 14 13 S2BMOD

VBAT 22 19 DC 1

ESLC 51 50 VALUE={(V(5,51)/ABS(V(5,51)))\*(PWR(V(5,51)/(1e-6\*609),2.5))}

.MODEL DBODYMOD D (IS = 2.35e-12 RS = 2.21e-3 TRS1 = 2.47e-3 TRS2 = 3.97e-11 CJO = 6.34e-9 TT = 3.95e-8 M = 0.6)  
 .MODEL DBREAKMOD D (RS = 9.1e-2 TRS1 = -2.24e-4 TRS2 = 5.23e-6)  
 .MODEL DPLCAPMOD D (CJO = 21.5e-10 IS = 1e-30 N = 10 M = 0.73)  
 .MODEL MMEDMOD NMOS (VTO = 3.30 KP = 5.49 IS = 1e-30 N = 10 TOX = 1 L = 1u W = 1u RG = 0.36)  
 .MODEL MSTROMOD NMOS (VTO = 3.87 KP = 145 IS = 1e-30 N = 10 TOX = 1 L = 1u W = 1u)  
 .MODEL MWEAKMOD NMOS (VTO = 2.92 KP = 0.050 IS = 1e-30 N = 10 TOX = 1 L = 1u W = 1u RG = 3.6 RS = 0.1)  
 .MODEL RBREAKMOD RES (TC1 = 1.04e-3 TC2 = 3.43e-7)  
 .MODEL RDRAINMOD RES (TC1 = 4.44e-3 TC2 = 8.04e-5)  
 .MODEL RSLCMOD RES (TC1 = 1.02e-4 TC2 = 2.07e-6)  
 .MODEL RSOURCEMOD RES (TC1 = 0 TC2 = 0)  
 .MODEL RVTHRESMOD RES (TC = -3.49e-3 TC2 = -1.27e-5)  
 .MODEL RVTEMPMOD RES (TC1 = -1.93e-3 TC2 = -1.38e-6)

.MODEL S1AMOD VSWITCH (RON = 1e-5 ROFF = 0.1 VON = -6.90 VOFF = -3.90)  
 .MODEL S1BMOD VSWITCH (RON = 1e-5 ROFF = 0.1 VON = -3.90 VOFF = -6.90)  
 .MODEL S2AMOD VSWITCH (RON = 1e-5 ROFF = 0.1 VON = 0.39 VOFF = 3.39)  
 .MODEL S2BMOD VSWITCH (RON = 1e-5 ROFF = 0.1 VON = 3.39 VOFF = 0.39)

.ENDS

NOTE: For further discussion of the PSPICE model, consult **A New PSPICE Sub-Circuit for the Power MOSFET Featuring Global Temperature Options**; IEEE Power Electronics Specialist Conference Records, 1991, written by William J. Hepp and C. Frank Wheatley.

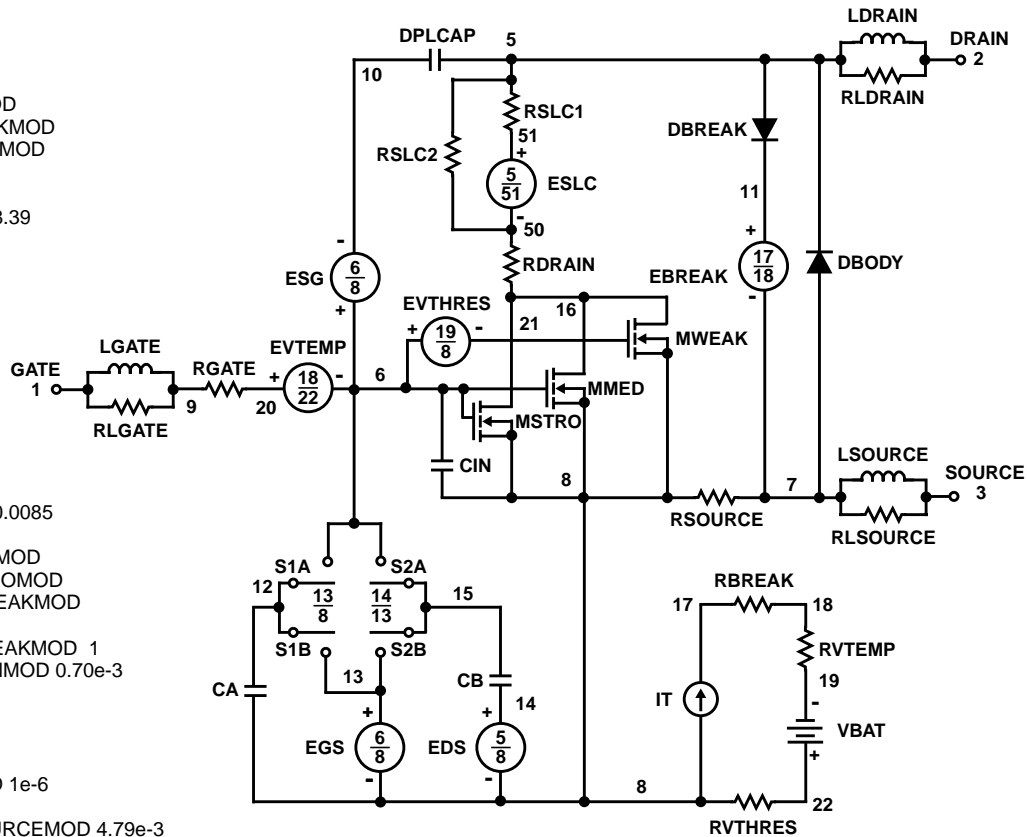

**PSPICE Thermal Model**

REV 27 May 97

HUF75343

CTHERM1 7 6 5.00e-7  
 CHERM2 6 5 7.50e-4  
 CHERM3 5 4 5.50e-3  
 CHERM4 4 3 1.80e-2  
 CHERM5 3 2 1.80e-1  
 CHERM6 2 1 6.00e-1

RHERM1 7 6 5.00e-6  
 RHERM2 6 5 1.38e-2  
 RHERM3 5 4 4.50e-2  
 RHERM4 4 3 2.40e-1  
 RHERM5 3 2 3.80e-1  
 RHERM6 2 1 3.00e-1

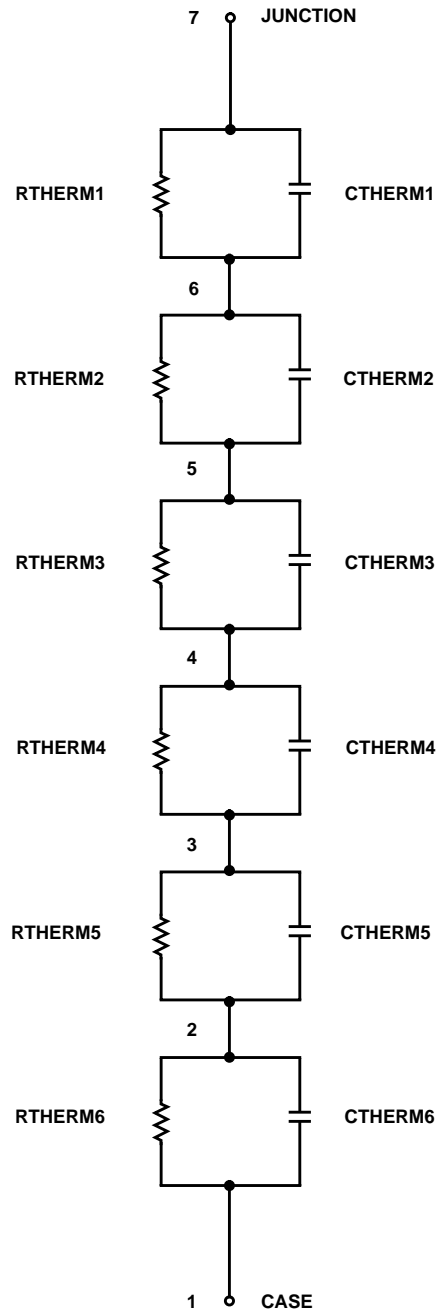



HUF75343G3, HUF75343P3, HUF75343S3, HUF75343S3S

TO-247

3 LEAD JEDEC STYLE TO-247 PLASTIC PACKAGE

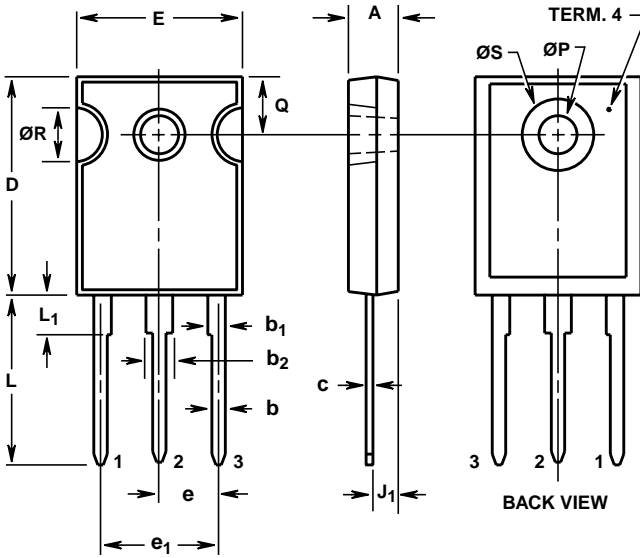

SYMBOL	INCHES		MILLIMETERS		NOTES
	MIN	MAX	MIN	MAX	
A	0.180	0.190	4.58	4.82	-
b	0.046	0.051	1.17	1.29	2, 3
b <sub>1</sub>	0.060	0.070	1.53	1.77	1, 2
b <sub>2</sub>	0.095	0.105	2.42	2.66	1, 2
c	0.020	0.026	0.51	0.66	1, 2, 3
D	0.800	0.820	20.32	20.82	-
E	0.605	0.625	15.37	15.87	-
e	0.219 TYP		5.56 TYP		4
e <sub>1</sub>	0.438 BSC		11.12 BSC		4
J <sub>1</sub>	0.090	0.105	2.29	2.66	5
L	0.620	0.640	15.75	16.25	-
L <sub>1</sub>	0.145	0.155	3.69	3.93	1
ØP	0.138	0.144	3.51	3.65	-
Q	0.210	0.220	5.34	5.58	-
ØR	0.195	0.205	4.96	5.20	-
ØS	0.260	0.270	6.61	6.85	-

NOTES:

1. Lead dimension and finish uncontrolled in L<sub>1</sub>.
2. Lead dimension (without solder).
3. Add typically 0.002 inches (0.05mm) for solder coating.
4. Position of lead to be measured 0.250 inches (6.35mm) from bottom of dimension D.
5. Position of lead to be measured 0.100 inches (2.54mm) from bottom of dimension D.
6. Controlling dimension: Inch.
7. Revision 1 dated 1-93.

HUF75343G3, HUF75343P3, HUF75343S3, HUF75343S3S

**TO-220AB**

**3 LEAD JEDEC TO-220AB PLASTIC PACKAGE**

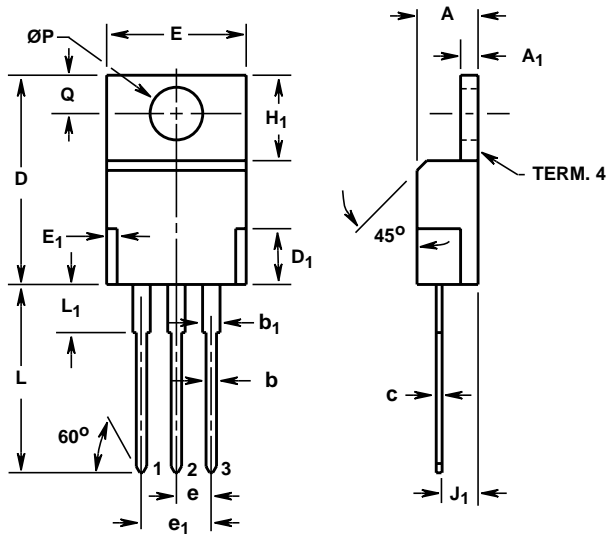

SYMBOL	INCHES		MILLIMETERS		NOTES
	MIN	MAX	MIN	MAX	
A	0.170	0.180	4.32	4.57	-
A <sub>1</sub>	0.048	0.052	1.22	1.32	-
b	0.030	0.034	0.77	0.86	3, 4
b <sub>1</sub>	0.045	0.055	1.15	1.39	2, 3
c	0.014	0.019	0.36	0.48	2, 3, 4
D	0.590	0.610	14.99	15.49	-
D <sub>1</sub>	-	0.160	-	4.06	-
E	0.395	0.410	10.04	10.41	-
E <sub>1</sub>	-	0.030	-	0.76	-
e	0.100 TYP		2.54 TYP		5
e <sub>1</sub>	0.200 BSC		5.08 BSC		5
H <sub>1</sub>	0.235	0.255	5.97	6.47	-
J <sub>1</sub>	0.100	0.110	2.54	2.79	6
L	0.530	0.550	13.47	13.97	-
L <sub>1</sub>	0.130	0.150	3.31	3.81	2
ØP	0.149	0.153	3.79	3.88	-
Q	0.102	0.112	2.60	2.84	-

NOTES:

1. These dimensions are within allowable dimensions of Rev. J of JEDEC TO-220AB outline dated 3-24-87.
2. Lead dimension and finish uncontrolled in L<sub>1</sub>.
3. Lead dimension (without solder).
4. Add typically 0.002 inches (0.05mm) for solder coating.
5. Position of lead to be measured 0.250 inches (6.35mm) from bottom of dimension D.
6. Position of lead to be measured 0.100 inches (2.54mm) from bottom of dimension D.
7. Controlling dimension: Inch.
8. Revision 2 dated 7-97.

HUF75343G3, HUF75343P3, HUF75343S3, HUF75343S3S

**TO-262AA** 3 LEAD JEDEC TO-262AA PLASTIC PACKAGE

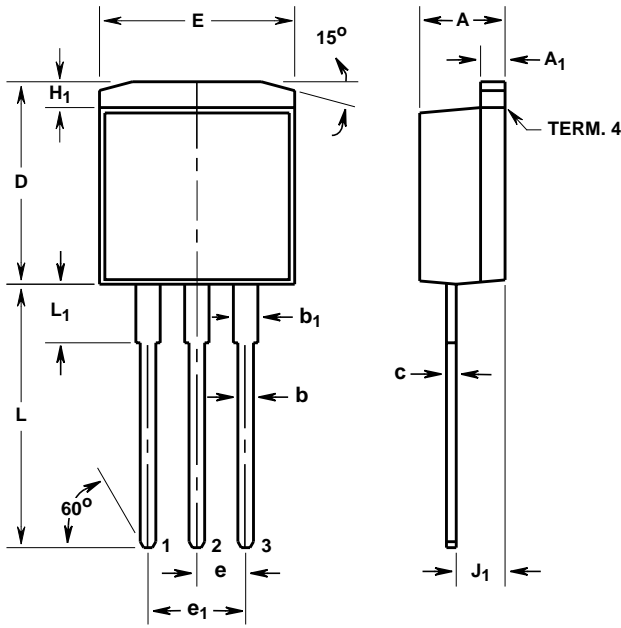

SYMBOL	INCHES		MILLIMETERS		NOTES
	MIN	MAX	MIN	MAX	
A	0.170	0.180	4.32	4.57	-
A <sub>1</sub>	0.048	0.052	1.22	1.32	3, 4
b	0.030	0.034	0.77	0.86	3, 4
b <sub>1</sub>	0.045	0.055	1.15	1.39	3, 4
c	0.018	0.022	0.46	0.55	3, 4
D	0.405	0.425	10.29	10.79	-
E	0.395	0.405	10.04	10.28	-
e	0.100 TYP		2.54 TYP		5
e <sub>1</sub>	0.200 BSC		5.08 BSC		5
H <sub>1</sub>	0.045	0.055	1.15	1.39	-
J <sub>1</sub>	0.095	0.105	2.42	2.66	6
L	0.530	0.550	13.47	13.97	-
L <sub>1</sub>	0.110	0.130	2.80	3.30	2

NOTES:

1. These dimensions are within allowable dimensions of Rev. A of JEDEC TO-262AA outline dated 6-90.
2. Solder finish uncontrolled in this area.
3. Dimension (without solder).
4. Add typically 0.002 inches (0.05mm) for solder plating.
5. Position of lead to be measured 0.250 inches (6.35mm) from bottom of dimension D.
6. Position of lead to be measured 0.100 inches (2.54mm) from bottom of dimension D.
7. Controlling dimension: Inch.
8. Revision 5 dated 7-97.

**TO-263AB** SURFACE MOUNT JEDEC TO-263AB PLASTIC PACKAGE

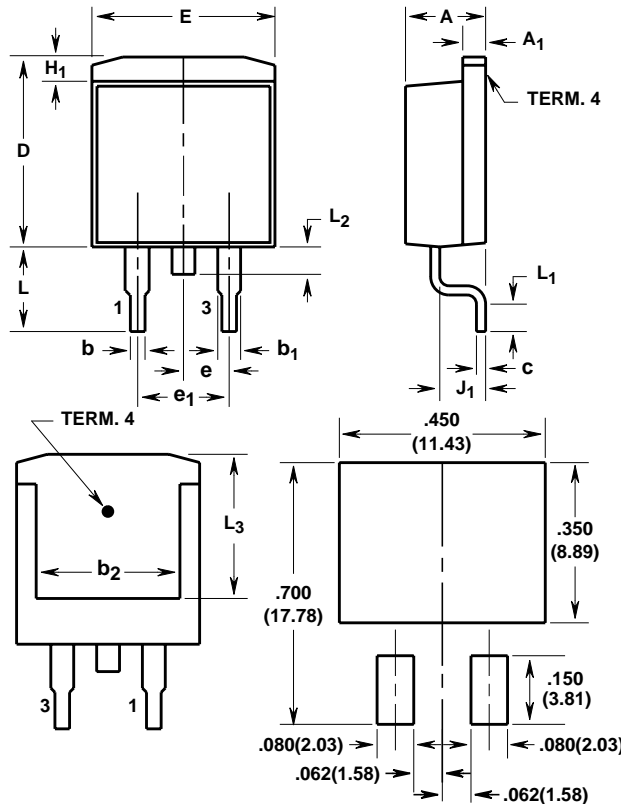

SYMBOL	INCHES		MILLIMETERS		NOTES
	MIN	MAX	MIN	MAX	
A	0.170	0.180	4.32	4.57	-
A <sub>1</sub>	0.048	0.052	1.22	1.32	4, 5
b	0.030	0.034	0.77	0.86	4, 5
b <sub>1</sub>	0.045	0.055	1.15	1.39	4, 5
b <sub>2</sub>	0.310	-	7.88	-	2
c	0.018	0.022	0.46	0.55	4, 5
D	0.405	0.425	10.29	10.79	-
E	0.395	0.405	10.04	10.28	-
e	0.100 TYP		2.54 TYP		7
e <sub>1</sub>	0.200 BSC		5.08 BSC		7
H <sub>1</sub>	0.045	0.055	1.15	1.39	-
J <sub>1</sub>	0.095	0.105	2.42	2.66	-
L	0.175	0.195	4.45	4.95	-
L <sub>1</sub>	0.090	0.110	2.29	2.79	4, 6
L <sub>2</sub>	0.050	0.070	1.27	1.77	3
L <sub>3</sub>	0.315	-	8.01	-	2

NOTES:

9. These dimensions are within allowable dimensions of Rev. C of JEDEC TO-263AB outline dated 2-92.
10. L<sub>3</sub> and b<sub>2</sub> dimensions established a minimum mounting surface for terminal 4.
11. Solder finish uncontrolled in this area.
12. Dimension (without solder).
13. Add typically 0.002 inches (0.05mm) for solder plating.
14. L<sub>1</sub> is the terminal length for soldering.
15. Position of lead to be measured 0.120 inches (3.05mm) from bottom of dimension D.
16. Controlling dimension: Inch.
17. Revision 8 dated 7-97.

MINIMUM PAD SIZE RECOMMENDED FOR SURFACE-MOUNTED APPLICATIONS

HUF75343G3, HUF75343P3, HUF75343S3, HUF75343S3S

**TO-263AB**

24mm TAPE AND REEL

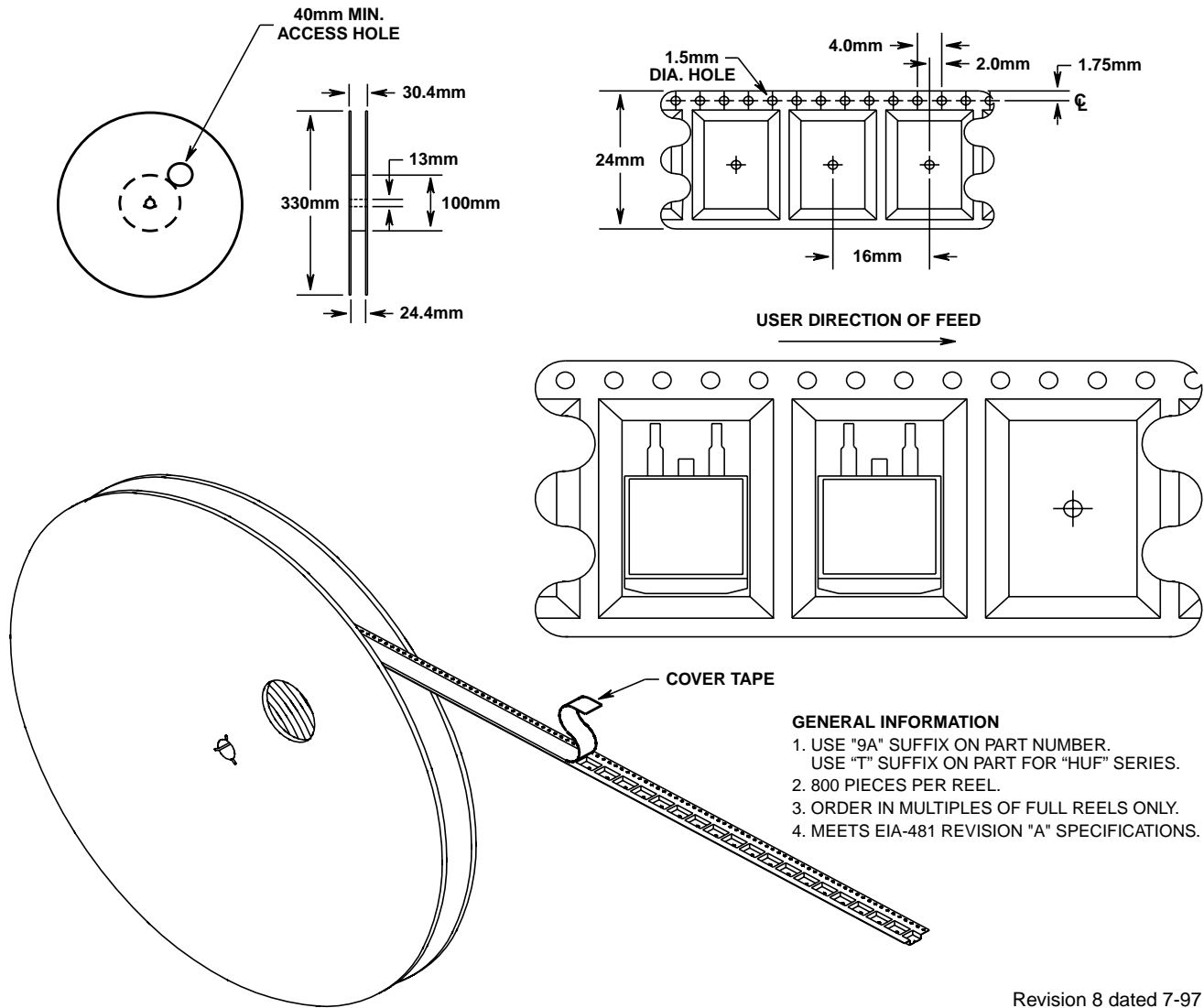

**GENERAL INFORMATION**

1. USE "9A" SUFFIX ON PART NUMBER.  
USE "T" SUFFIX ON PART FOR "HUF" SERIES.
2. 800 PIECES PER REEL.
3. ORDER IN MULTIPLES OF FULL REELS ONLY.
4. MEETS EIA-481 REVISION "A" SPECIFICATIONS.

Revision 8 dated 7-97

All Harris Semiconductor products are manufactured, assembled and tested under **ISO9000** quality systems certification.

*Harris Semiconductor products are sold by description only. Harris Semiconductor reserves the right to make changes in circuit design and/or specifications at any time without notice. Accordingly, the reader is cautioned to verify that data sheets are current before placing orders. Information furnished by Harris is believed to be accurate and reliable. However, no responsibility is assumed by Harris or its subsidiaries for its use; nor for any infringements of patents or other rights of third parties which may result from its use. No license is granted by implication or otherwise under any patent or patent rights of Harris or its subsidiaries.*

**Sales Office Headquarters**

For general information regarding Harris Semiconductor and its products, call **1-800-4-HARRIS**

**NORTH AMERICA**  
 Harris Semiconductor  
 P. O. Box 883, Mail Stop 53-210  
 Melbourne, FL 32902  
 TEL: 1-800-442-7747  
 (407) 729-4984  
 FAX: (407) 729-5321

**EUROPE**  
 Harris Semiconductor  
 Mercure Center  
 100, Rue de la Fusee  
 1130 Brussels, Belgium  
 TEL: (32) 2.724.2111  
 FAX: (32) 2.724.22.05

**ASIA**  
 Harris Semiconductor PTE Ltd.  
 No. 1 Tannery Road  
 Cencon 1, #09-01  
 Singapore 1334  
 TEL: (65) 748-4200  
 FAX: (65) 748-0400

