

Contents	Page
Introduction	5
1 Features	7
2 System Description	13
2.1 Display Modes	13
2.2 Input Signal Processing	19
2.2.1 Data Transfer	19
2.2.2 Decimation Window	19
2.2.3 Decimation Filters	20
2.3 PIP Field Memory	21
2.3.1 Picture Sizes	21
2.3.2 Memory Writing	22
2.3.3 Memory Reading and Synchronization to Parent Channel	22
2.4 Output Signal Processing	23
2.4.1 Display Position	23
2.4.2 Interpolation of the Chrominance Signals	24
2.4.3 Framing	24
2.4.4 Full Screen Background Insertion	24
2.4.5 Wipe In / Wipe Out Facility	25
2.4.6 Output Formats and RGB Conversion	25
2.4.7 Select Signal	26
2.4.8 Blanking Signals	26
2.4.9 Pedestal for the Chrominance Signals	27
2.5 Digital to Analog Conversion	27
2.5.1 Analog Video Outputs	27
2.5.2 Analog Control Signal	27
2.6 On Screen Display	27
2.6.1 Display Format	27
2.6.2 Character Programming	27
2.6.3 Character and Character Background Luminance	28
2.6.4 Character Set	28
2.7 Numerical PLL	30
2.8 I ² C Bus	30
2.8.1 I ² C Bus Addresses	30
2.8.2 I ² C Bus Receiver Format	30
2.8.3 I ² C Bus Commands	31
3 Absolute Maximum Ratings	40
4 Recommended Operating Conditions	41
5 Characteristics	45

Contents		Page
6	Application Information	48
7	Waveforms	49
7.1	Phase Relation of Sync Pulses at Frame Mode	49
8	Package Outlines	51

Introduction

SDA 9189X Quarter-PIP Chip Sets the Pace for Picture-in-Picture Systems

The SDA 9189X integrated circuit is Siemens first picture-in-picture system for quarter size-PIP images. It offers manufacturers of high-end television sets in particular extra scope for product enhancement. Thanks to its 329Kbit on-chip memory, pictures from 1/4 to 1/36 of the screen size can be selected, while the multi-PIP feature permits simultaneous presentation of up to nine different images plus on-screen display of menus and settings. Advanced functions such as Picture outside Picture (POP) for 16:9 TV sets tuner scanning and strobe effects, which were previously reserved for absolute top-of-the-range sets with multistandard conversion and field memories, can now be implemented at reasonable cost.

Preliminary Data

1 Features

- **High system integration**

Filtering, field memory, RGB-matrix, DA-Conversion, clock generation, and control circuits integrated on one chip

- **4 picture sizes**

1/4th, 1/9th, 1/16th, or 1/36th of normal size

- **High resolution display**

13.5 MHz / 27 MHz display clock frequency

288 luminance and 72 chrominance pixels per inset line for picture size 1/4

6 bit amplitude resolution for each incoming signal component

Frame mode display in single PIP modes

Horizontal and vertical filtering

Special antialias filtering for the luminance signal

- **Single and Multi PIP display**

Up to 9 pictures of 1/36th size (8 still and 1 moving)

Up to 4 pictures of 1/16th size (3 still and 1 moving)

Up to 2 pictures of 1/9th size (1 still and 1 moving)

Up to 3 pictures of 1/9th size (2 still and 1 moving) as POP display in 16:9 TV sets
(In multi PIP modes only field mode display possible)

- **Multistandard applications**

Automatic recognition of 625 lines / 525 lines standard (inset and parent channel)

Scan conversion systems as flickerfree display systems (parent channel)

HDTV (parent channel)

- **16:9 compatibility**

Operation in 4:3 and 16:9 TV sets

4:3 inset signals on 16:9 displays (picture size 1/4 and 1/9)

16:9 inset signals on 4:3 displays (picture size 1/9 and 1/16)

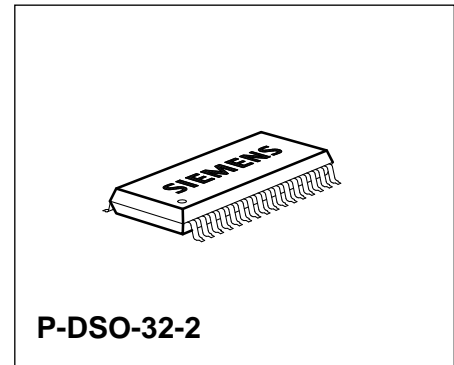

Type	Ordering Code	Package
SDA 9189X		P-DSO-32-2 (SMD)

- **Digital inputs**
Y, + (B-Y), + (R-Y)
Compatible with Triple ADC SDA 9187-2X
- **Analog outputs**
Y, + (B-Y), + (B-Y) or Y, - (B-Y), - (B-Y) or RGB
3 RGB-matrices: EBU, NTSC (Japan), NTSC (USA)
- **Digital to analog converter output e.g. for color decoder adjustment**
6 bit resolution
- **Freely programmable position of inset picture**
Steps of 1 pixel and 1 line
All PIP and POP positions are possible inside the standard display area
- **Programmable framing**
4096 frame colors
Variable frame width
- **Full screen background insertion**
64 background colors or transparent display (parent picture seen)
- **Wipe in / Wipe out facility**
Start and end of insertion is the lower right PIP corner
4 periods programmable
- **Freeze picture**
- **I²C Bus control**
- **Up to three ICs in one application**
Three different I²C bus addresses
Up to 3 moving pictures using 3 ICs
Up to 27 pictures of 1/36 th size
- **On-screen display of channel index**
64 characters programmable (alphanumeric and special symbols)
5 characters displayed in every PIP picture
4 different character luminance values (B-Y = R-Y = 0)
4 background luminance values (B-Y = R-Y = 0) or transparent mode (inset picture seen)
- **Numerical display PLL circuit for high stability clock generation**
- **No necessity of PAL/SECAM delay lines when using suitable color decoders**
- **P-DSO-32 package / 350 mil (SMD)**
- **5 V supply voltage**

Pin Configuration
(top view)

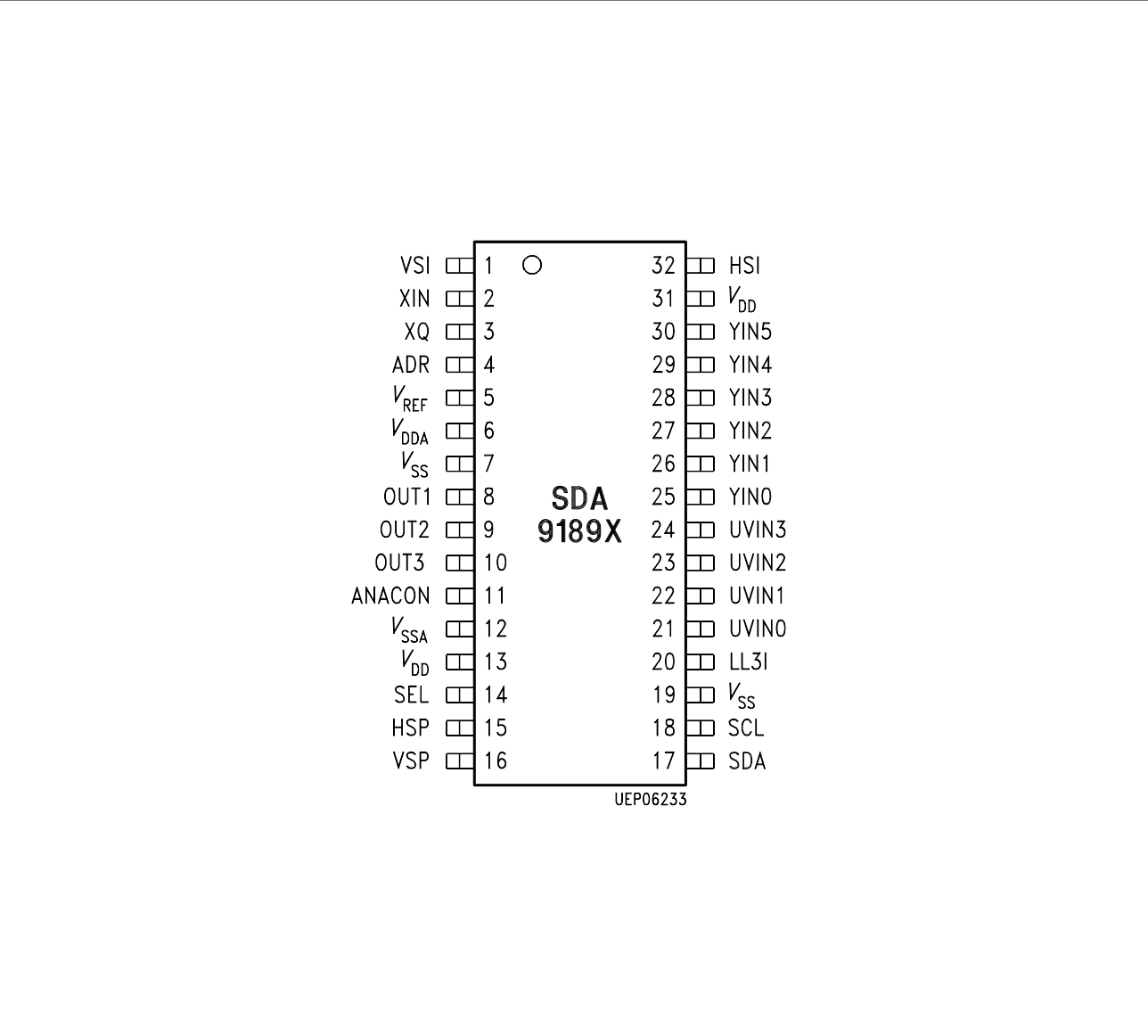

Pin Definitions and Functions

Pin No.	Symbol	Function	Descriptions
1	VSI	I/TTL	Inset vertical sync input
2	XIN	I	PLL quartz oscillator input
3	XQ	Q	PLL quartz oscillator output
4	ADR	I/3-L	I ² C address
5	V _{REF}	I/ana	DACs reference voltage
6	V _{DDA}	S	DACs and PLL positive voltage supply
7	V _{SS}	S	Digital ground
8	OUT1	Q/ana	Analog output R or + (R-Y) or – (R-Y)
9	OUT2	Q/ana	Analog output G or Y
10	OUT3	Q/ana	Analog output B or + (B-Y) or – (B-Y)
11	ANACON	Q/ana	analog output (e.g. color decoder adjustment)
12	V _{SSA}	S	DACs and PLL ground
13	V _{DD}	S	Digital positive voltage supply
14	SEL	Q/var	Signals OUT1 - OUT3 valid
15	HSP	I/TTL	Parent horizontal sync input
16	VSP	I/TTL	parent vertical sync input
17	SDA	IQ/TTL	I ² C data input/output
18	SCL	I/TTL	I ² C clock
19	V _{SS}	S	Digital ground
20	LL3I	I/TTL	Line locked clock inset picture
21	UVIN0	I/TTL	Digital UV input data
22	UVIN1	I/TTL	Digital UV input data
23	UVIN2	I/TTL	Digital UV input data

Pin Definitions and Functions (cont'd)

Pin No.	Symbol	Function	Descriptions
24	UVIN3	I/TTL	Digital UV input data
25	YIN0	I/TTL	Digital Y input data
26	YIN1	I/TTL	Digital Y input data
27	YIN2	I/TTL	Digital Y input data
28	YIN3	I/TTL	Digital Y input data
29	YIN4	I/TTL	Digital Y input data
30	YIN5	I/TTL	Digital Y input data
31	V_{DD}	S	Digital positive voltage supply
32	HSI	I/TTL	Inset horizontal sync input

S: supply, I: input, Q: output, TTL: digital (TTL), ana: analog, 3-L: 3 level signal, var: variable configuration of output stage (open source, open drain, TTL)

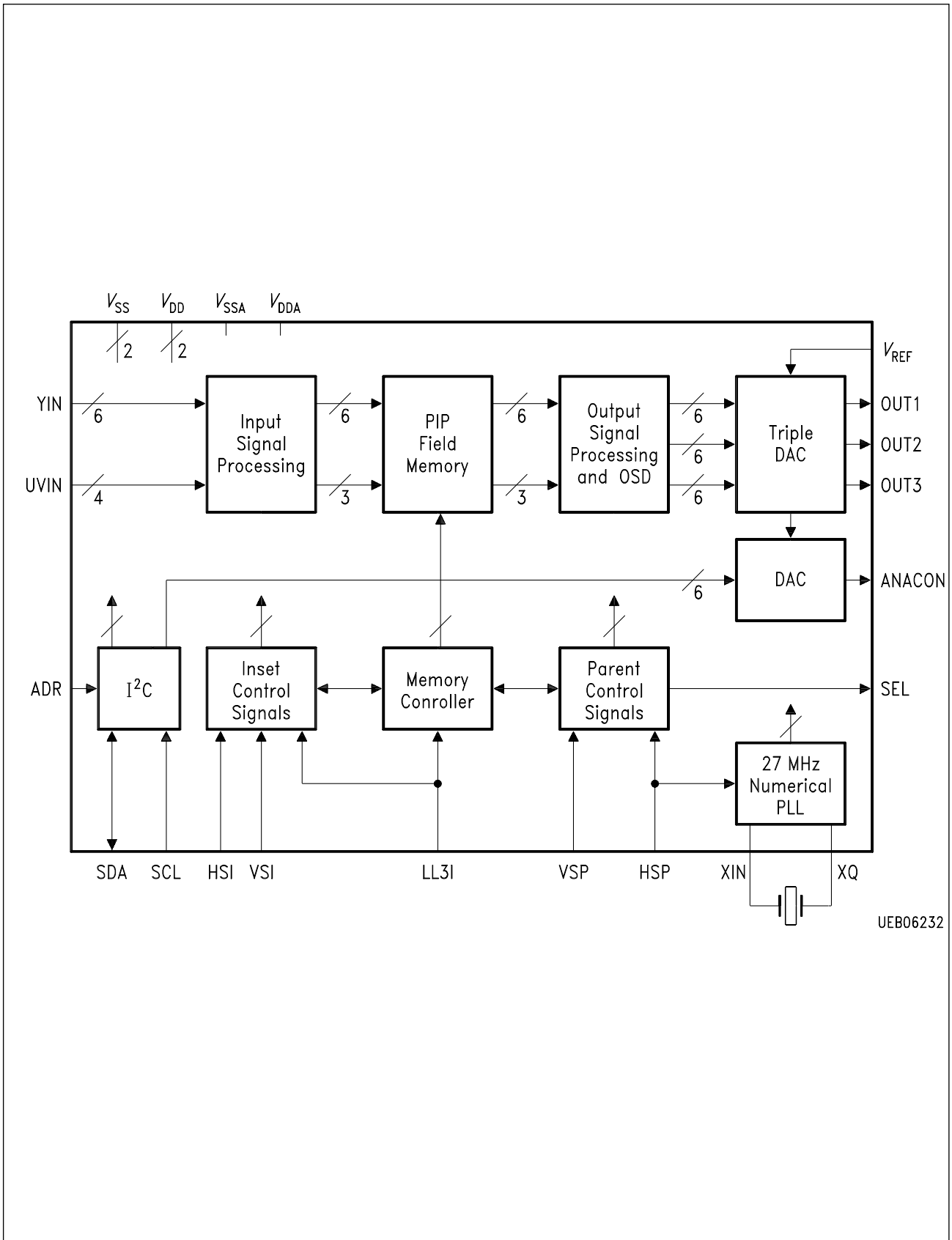

UEB06232

Block Diagram

2 System Description

2.1 Display Modes

8 single and 10 multi PIP display modes are available. Decimation, memory controlling, framing and on screen display insertion depend on the selected display mode (PIPMOD).

In the multi PIP modes the complete inset picture can contain up to 9 partial pictures (see diagrams below). One of the partial pictures shows a moving picture, whereas the others show still pictures. The partial picture that has to be written is addressed via I²C bus. The addresses (WRPOS) for the individual pictures are shown in the diagrams. The same addresses serve to choose the position of the moving picture. The multi PIP modes allow tuner scanning.

Four display modes are provided for applications with 16:9 inset signals or displays (**see table**). The single PIP display modes 15 and 18 can be used to display 4:3 inset signals on 16:9 displays. To show 16:9 inset signals on 4:3 displays the single PIP display modes 16 and 19 have been added. By means of multi PIP display mode 17 a POP picture on a 16:9 display can be created.

If a display mode is chosen that is not realized (modes 9, 12, and 20 to 31), the PIP insertion is switched off automatically (PIPON = 0).

Display Mode (PIPMOD)	Picture Size, Picture Configuration
0 (00000)	1 × 1/4
1 (00001)	1 × 1/9
2 (00010)	1 × 1/16
3 (00011)	1 × 1/36
4 (00100)	4 × 1/16, 2 rows of 2 pictures
5 (00101)	4 × 1/16, side by side
6 (00110)	4 × 1/16, one upon another
7 (00111)	9 × 1/36, 3 rows of 3 pictures
8 (01000)	2 × 1/9, side by side
9 (01001)	not realized (PIPON = 0)

Display Mode (PIPMOD)	Picture Size, Picture Configuration
10 (01010)	8 × 1/36, 2 rows of 4 pictures
11 (01011)	2 × 1/9, one upon another
12 (01100)	not realized (PIPON = 0)
13 (01101)	8 × 1/36, 2 columns of 4 pictures one upon another
14 (01110)	4 × 1/36, 2 rows of 2 pictures
15 (01111)	1 × 1/9, 4:3 inset signal on 16:9 display horizontal decimation 4:1, vertical decimation 3:1
16 (10000)	1 × 1/16, 16:9 inset signal on 4:3 display horizontal decimation 3:1, vertical decimation 4:1
17 (10001)	3 × 1/9, 4:3 inset signals on 16:9 display horizontal decimation 4:1, vertical decimation 3:1 one upon another
18 (10010)	1 × 1/4, 4:3 inset signal on 16:9 display horizontal decimation 3:1, vertical decimation 2:1
19 (10011)	1 × 1/9, 16:9 inset signal on 4:3 display horizontal decimation 2:1, vertical decimation 3:1
20 (10100)	not realized (PIPON = 0)
⋮	
31 (11111)	

The following diagrams show the various display modes. The figures on top of the rectangles give the width of the complete inset picture in pixels whereas the figures on the right specify its height by the number of lines. The values for the multi PIP display modes are obtained by adding the widths and heights of the partial pictures. The sizes of the partial pictures correspond to the sizes of the inset pictures of the single PIP modes (see below).

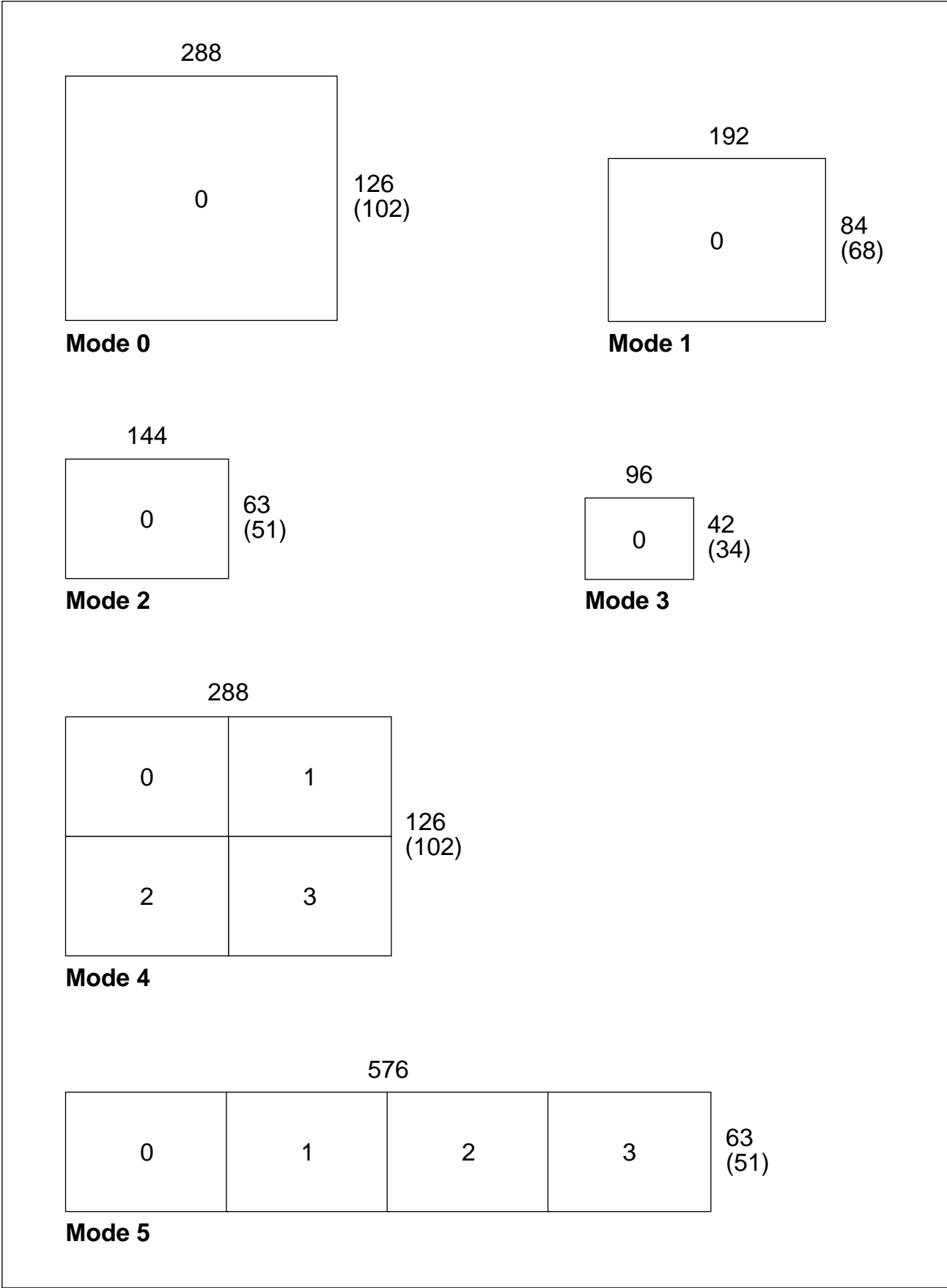

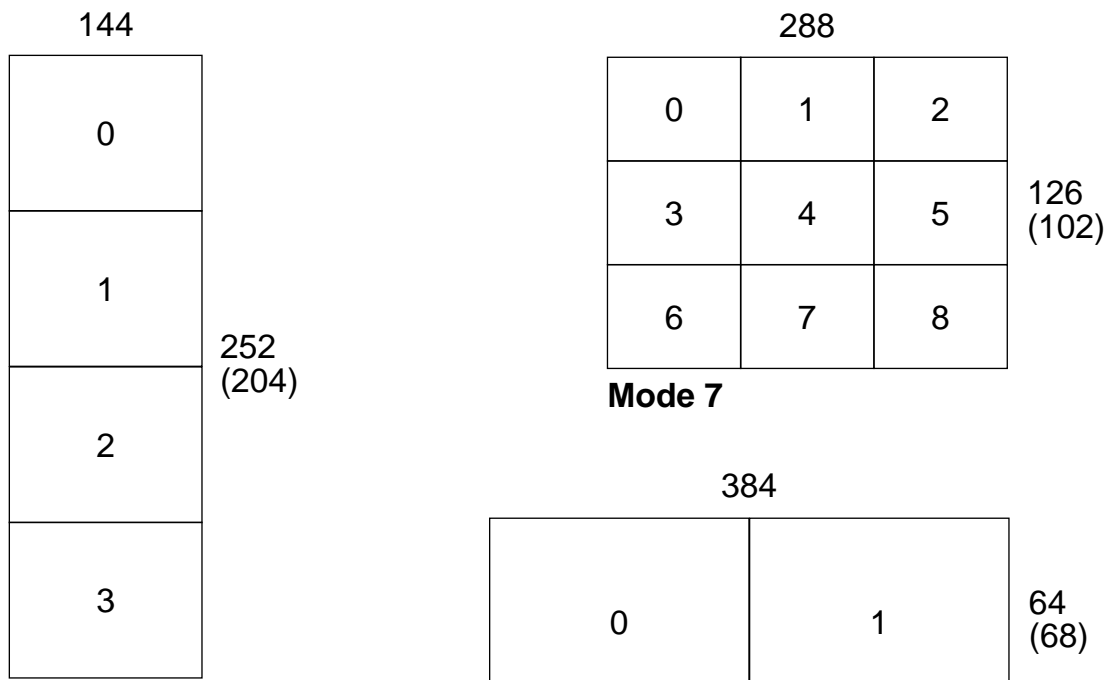

Mode 6

Mode 7

Mode 8

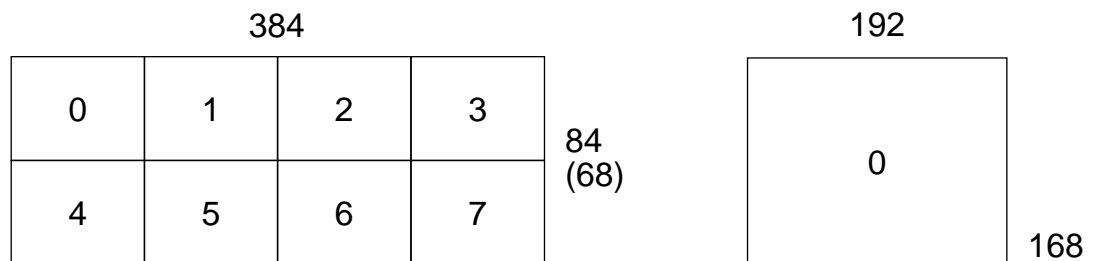

Mode 10

Mode 11

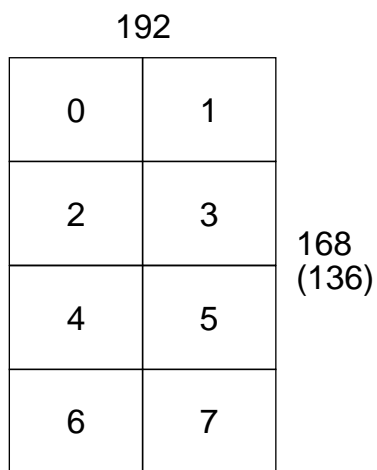

Mode 13

The display modes 9 and 12 are not realized.
 For a PIP display line standard of 525 lines the values in parenthesis are valid.

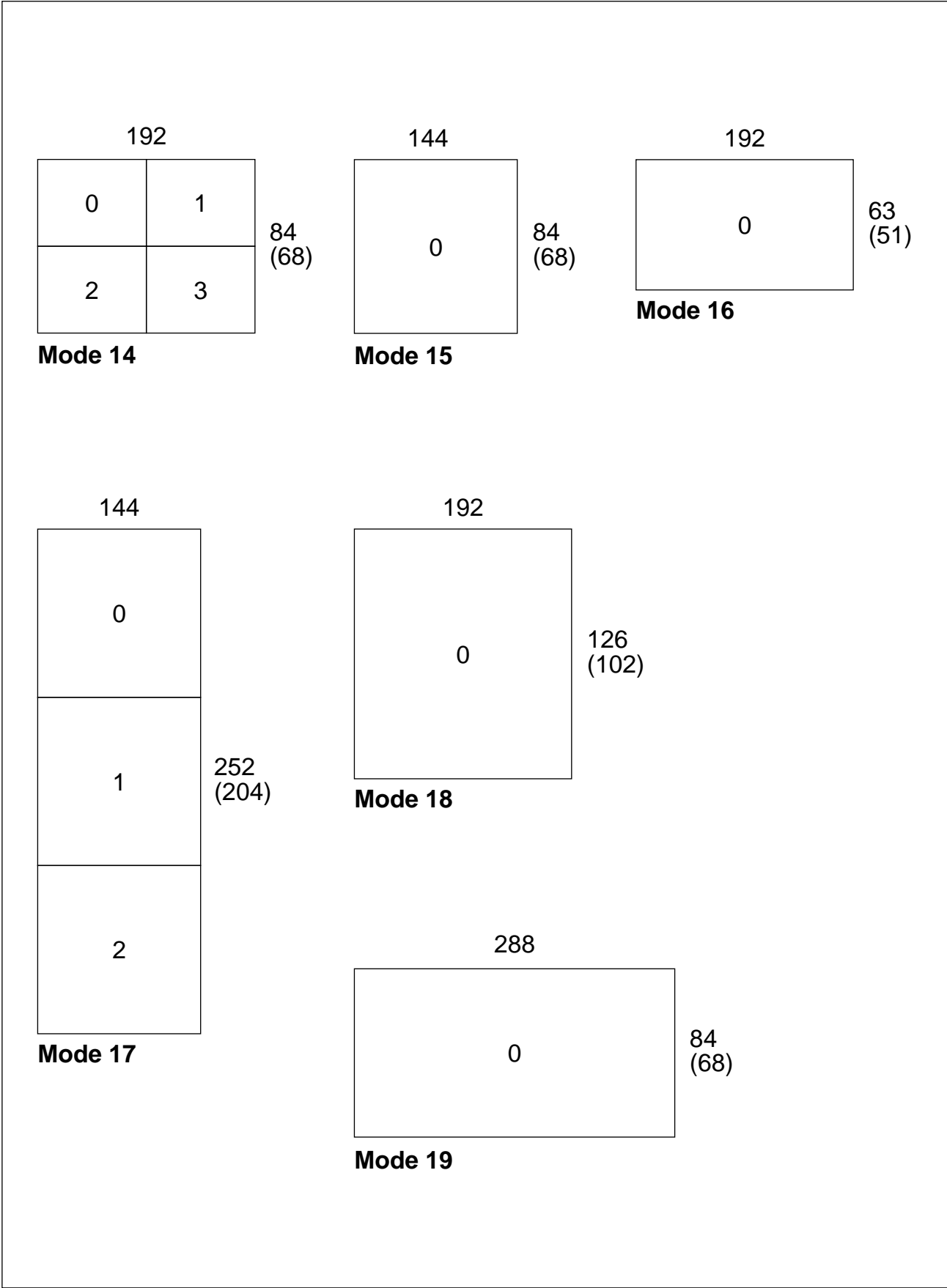

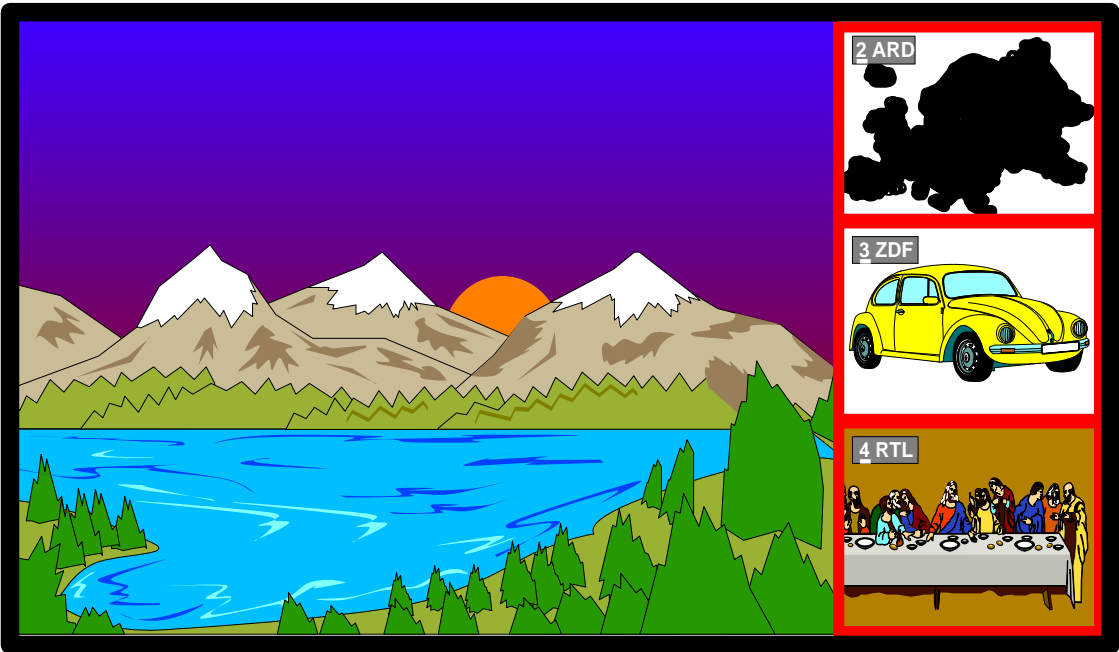

Multi POP Feature at 16:9 Application with Display Mode 17 and OSD
Main Picture and one POP Picture live, all other Pictures still

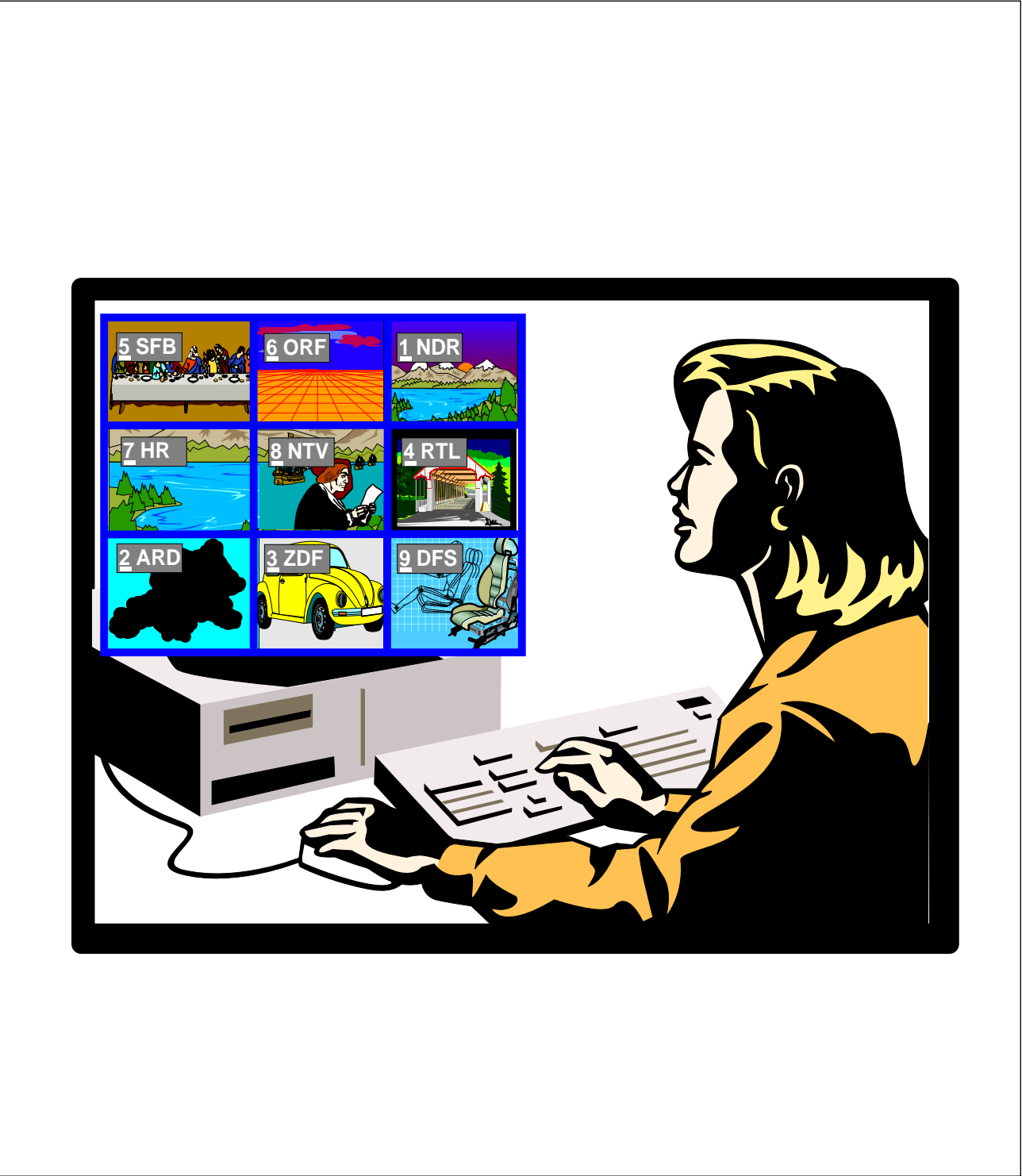

Multi PIP Feature with Display Mode 7
Main Picture and one PIP Picture live, all other Picture still

2.2 Input Signal Processing

2.2.1 Data Transfer

The inset video signal is accepted as digital luminance and chrominance components with a 13.5 MHz clock for the luminance signal and a 3.375 MHz clock for the chrominance signals.

Inset synchronization is done via pin HSI for horizontal and pin VSI for vertical synchronization. By analyzing the synchronization pulses the line standard of the inset signal source is detected and interference noise on the vertical sync signal is removed. For applications with fixed line standard (625 lines or 525 lines) the automatic detection can be switched off.

The phase of the vertical sync pulse is programmable (VSIDEL) (see waveforms). This way a correct detection of the field number is possible, an important condition for frame mode display.

2.2.2 Decimation Window

A window signal, derived from the sync pulses and the detected line standard, defines the part of the active video area used for decimation. The window has a width of 576 pixels for the luminance signal and a width of 144 pixels for the chrominance signals. In the vertical direction the window consists of 252 or 204 lines depending on the line standard (625 or 525 lines respectively).

The horizontal position of this decimation window can be adapted to various applications with the help of a programmable delay of the luminance signal (HSIDEL) relative to the horizontal synchronization pulses. For $HSIDEL = 0$ the decimation window is opened 0 clock periods (13.5 MHz) after the horizontal synchronization pulse. For the 625 lines standard the 42th video line is the first decimated line, for the 525 lines standard decimation starts in the 38th video line.

2.2.3 Decimation Filters

The input signal is decimated by subsampling with horizontal and vertical filtering. A special antialias filter improves the frequency response of the luminance channel.

The following decimation filters are implemented:

Horizontal Decimation	Luminance Filter	Chrominance Filter
2:1	{ 1 1 }	{ 1 1 }
3:1	{ 1 1 1 }	{ 1 2 1 }
4:1	{ 1 1 1 1 }	{ 1 1 1 1 }
6:1	{ 1 1 1 1 1 1 }	{ 1 1 2 2 1 1 }

Vertical Decimation	Luminance Filter	Chrominance Filter
2:1	{ 1 1 }	{ 1 1 }
3:1	{ 1 1 1 }	{ 1 2 1 }
4:1	{ 1 1 1 1 }	{ 1 1 1 1 }
6:1	{ 1 1 1 1 1 1 }	{ 1 1 2 2 1 1 }

The realized chrominance filtering allows omitting the color decoder delay line for PAL and SECAM demodulation if the color decoder supplies the same output voltages independent of the kind of operation. In case of SECAM signals an amplification of the chrominance signals by a factor of 2 is necessary because there is a signal only in every second line. This chrominance amplification is programmable via I²C bus (AMSEC).

2.3 PIP Field Memory

The on-chip memory has a capacity of 329184 bits. It stores one decimated field of the inset picture. In the multi PIP display modes the memory is able to store one decimated field of every partial picture (e.g. during tuner scanning).

2.3.1 Picture Sizes

The picture size depends on the horizontal and vertical decimation factors.

Horizontal Decimation	Pixels / Line
2:1	288
3:1	192
4:1	144
6:1	96

Vertical Decimation	Lines / Field (625 lines standard)	Lines / Field (525 lines standard)
2:1	126	102
3:1	84	68
4:1	63	51
6:1	42	34

2.3.2 Memory Writing

To get equal clock frequencies for luminance and chrominance signals a multiplexer at the memory input generates a 3 bit data format for both chrominance components.

In field mode display only every second inset field is written into the memory, in frame mode display the memory is written continuously. Data are written with the lower inset clock frequency depending on the horizontal decimation factor (6.75 MHz, 4.5 MHz, 3.375 MHz, or 2.25 MHz).

Memory writing can be stopped by program (FREEZE), a freeze picture display results (one field).

In single PIP display modes frame mode display is possible having no scan conversion and the same number of lines in inset and parent channel (625 lines or 525 lines both). The result is a higher vertical and temporal resolution because of displaying every incoming field. The standards are analyzed internally and an activated frame mode display is switched to field mode display automatically when the described restrictions are no longer valid.

2.3.3 Memory Reading and Synchronization to Parent Channel

The reading frequency is normally 13.5 MHz and 27 MHz for scan conversion systems. For progressive scan conversion systems and HDTV displays a line doubling mode is available (LINEDBL). Every line of the inset picture is read twice.

Synchronization of memory reading with the parent channel is achieved by processing the parent horizontal and vertical synchronization signals. These signals are fed to the IC at pin HSP for horizontal synchronization and at pin VSP for vertical synchronization. A numerical PLL circuit generates a clock signal that is locked to the horizontal synchronization pulses of the parent channel. The burst gate of the sandcastle signal can be used for horizontal synchronization.

A field number detection is carried out for the inset channel as well as for the parent channel. Depending on the phase difference between inset and parent signals a correction of the display raster for the read out data is performed by omitting or inserting lines when the read address counter outruns the write address counter.

2.4 Output Signal Processing

2.4.1 Display Position

The display position of the inset picture is freely programmable (POSHOR, POSVER). The first possible picture position (without frame) is 55 clock periods (13.5 MHz or 27 MHz) after the horizontal and 7 lines after the vertical synchronization pulses. Starting at this position the picture can be moved over the whole display area. Even POP positions (Picture Outside Picture) can be used.

Note: Display without disturbances is only possible if the complete PIP picture is inside the visible area of the picture tube:

$$\text{POSHOR} < 1$$

$$\text{POSHOR} < 864 - 2 \times \text{FRWIDTH} - \text{PSH} - 42$$

$$\text{POSVER} < 262 - 2 \times \text{FRWIDV} - \text{PSV} - 8 \quad (60 \text{ Hz mode) or}$$

$$\text{POSVER} < 312 - 2 \times \text{FRWIDV} - \text{PSV} - 8 \quad (50 \text{ Hz mode)}$$

POS ... = Picture Position (see I²C bus)

FRWID. = Frame Width (see I²C bus)

PSH = Picture size horizontal (number of pixels)

PSV = Picture size vertical (number of line)

Line Standard of the PIP Picture

The line standard used to display the complete PIP picture is programmable via I²C bus (PIPLIN). The line standard of the parent channel or the inset channel can be used. In addition a fixed line standard of 625 or 525 lines can be chosen.

Combinations of different line standards of the inset signal and the PIP display are handled in a special way:

- PIP display 625 lines, inset signal 525 lines: The inset picture is shifted down by 12, 8, 6, or 4 lines according to picture size. Due to this shift the centres of the inset pictures have the same position for both line standards. The remaining 12, 8, 6, or 4 lines at the top and the bottom of the inset picture are filled with the luminance value of the full screen background color (BCKY). The chrominance values are set to 0 for these parts of the inset picture.
- PIP display 525 lines, inset signal 625 lines: The inset picture is reduced to 102, 68, 51, or 34 lines. Depending on the number of lines the first and the last 12, 8, 6, or 4 lines are omitted. In this way the display shows the centre part of the original picture.

Displaying multi PIP pictures this procedure is applied individually to each of the partial pictures.

2.4.2 Interpolation of the Chrominance Signals

At the memory output the chrominance components are demultiplexed and linearly interpolated to the luminance sampling rate.

2.4.3 Framing

In this part of the circuit a colored frame is added to the inset picture. 4096 frame colors are programmable, 4 bits for each component Y, (B-Y), (R-Y). The horizontal and vertical widths of the frame are independently programmable. In the multi PIP modes the various partial pictures are separated by inner frame elements. These parts of the frame have a fixed horizontal width of 4 pixels and a fixed vertical width of 2 lines. For INFR = 0 the inner frame elements are not inserted.

The outer frame elements border on the inset picture without limiting its size whereas the inner frame elements reduce the areas of the partial pictures.

2.4.4 Full Screen Background Insertion

Instead of showing the parent picture it is possible to fill the background (full screen picture without inset picture and its frame, BCKON = 1) with a programmable color. For BCKFR = 1 the background color is identical with the frame color, otherwise it is defined by 6 bits programmable via I²C bus: two bits for each component. The bits for the chrominance signals are used directly as MSB's of the output words B-Y and R-Y. The remaining LSB's are set to 0. Therefore 16 different colors are possible. The two bits for the Y signal choose a luminance value according to the following table (100 IRE corresponds to the full scale range of DAC input = integer value 63):

Background Luminance	IRE	Integer Value
0 0	20	12
0 1	30	19
1 0	40	25
1 1	50	31

Filling PIP Picture with Color

The whole inset picture can be filled with the frame color (FRCOL = 1) or the luminance value for the full screen background insertion without colors (BCKCOL = 1, FRCOL = 0). The frame elements remain visible. Filling the PIP picture with background is especially useful before starting a tuner scanning cycle.

2.4.5 Wipe In / Wipe Out Facility

With the wipe in / wipe out function it is possible to make appear or disappear the complete inset picture starting or ending at the lower right corner of the inset picture position. Thereby the size of the picture is continuously increased and decreased respectively. During this procedure the frame is shown with its chosen widths. 4 different periods are programmable via I²C bus.

2.4.6 Output Formats and RGB Conversion

Different output formats are available: luminance signal Y with inverted or non-inverted chrominance signals (B-Y), (R-Y) or RGB signals.

For the RGB conversion 3 matrices are provided:

Standard	Amplitudes			Angles		
	B-Y	R-Y	G-Y	B-Y	R-Y	G-Y
EBU	1	0.558	0.345	0°	90°	237°
NTSC (Japan)	1	0.783	0.31	0°	95°	240°
NTSC (USA)	1	1.013	0.305	0°	104°	252°

Matrix selection is done via I²C bus. The matrices are designed for the following voltages at the inputs of the ADC converter (the values correspond to 100 % white and 75 % color saturation):

Component	Input Voltage (without sync) in % of Full Scale Input Range of ADC
Y	75
B-Y	100
R-Y	100

Matrix Equations

EBU

$$\begin{bmatrix} B \\ R \\ G \end{bmatrix} = \begin{bmatrix} 1 & 0 & 1 \\ 0 & 0.78125 & 1 \\ -0.1875 & -0.40625 & 1 \end{bmatrix} \begin{bmatrix} B - Y \\ R - Y \\ Y \end{bmatrix}$$

NTSC (Japan)

$$\begin{bmatrix} B \\ R \\ G \end{bmatrix} = \begin{bmatrix} 1 & 0 & 1 \\ -0.0625 & 1.09375 & 1 \\ -0.15625 & -0.375 & 1 \end{bmatrix} \begin{bmatrix} B - Y \\ R - Y \\ Y \end{bmatrix}$$

NTSC (USA)

$$\begin{bmatrix} B \\ R \\ G \end{bmatrix} = \begin{bmatrix} 1 & 0 & 1 \\ -0.25 & 1.375 & 1 \\ -0.09375 & -0.40625 & 1 \end{bmatrix} \begin{bmatrix} B - Y \\ R - Y \\ Y \end{bmatrix}$$

2.4.7 Select Signal

For controlling an external fast switch (for example an RGB processor) a select signal SEL is supplied. The delay of this signal relative to the luminance and chrominance components is programmable for adaption to different external output signal processings. Three different characteristics of the output stage of this signal are available. An open source, an open drain, or a TTL output can be selected via I²C bus (SELMOD).

2.4.8 Blanking Signals

In case of full screen background insertion the circuit has to generate output signals with correctly positioned line-blanking intervals relative to the horizontal synchronization pulses of the parent channel. This can be achieved by a programmable delay (BLKDEL). A field-blanking interval with a length of 16 lines is also provided. It is triggered by the vertical synchronization pulse of the parent channel (VSP). The generation of this field-blanking signal can be activated via I²C bus (VERBLK = 1).

2.4.9 Pedestal for the Chrominance Signals

Both components of the chrominance signal are equipped with a programmable pedestal (white balance, PEDESTU, PEDESTV). The pedestal values are fed to the digital to analog converters during the line-blanking intervals. For each component a 4-bit value in 2's complement code is defined via I²C bus. Building up the 6-bit input words of the digital to analog converters these 4 bits are used as LSBs. The missing two MSBs are complemented by sign extension. In this way pedestal values from – 8 to + 7 LSBs of the digital to analog converters can be achieved.

2.5 Digital to Analog Conversion

2.5.1 Analog Video Outputs

The IC includes three 6-bit digital to analog converters for the video outputs. Each converter supplies a current through an external resistor that is placed between V_{SSA} and OUT1, OUT2, OUT3 respectively. The current is controlled by a digital control circuit.

2.5.2 Analog Control Signal

The additional 6-bit digital to analog converter that provides an analog control signal (e.g. for color decoder adjustment) is fed directly by a 6-bit signal programmable via I²C bus. No external resistor is needed at output ANACON.

2.6 On Screen Display

2.6.1 Display Format

The on screen display allows to insert a block of 5 characters into each of the PIP pictures. The characters are placed in a box (background) with a width of 64 pixels and a height of 12 lines. This box is situated in the upper left corner of the PIP pictures. The background box can be made transparent (CHARBCK = 0), i.e. behind the characters the inset picture becomes visible.

64 different characters are stored in a character ROM (see table below). Each character is defined by a pixel matrix consisting of 10 lines and 12 pixels per line.

2.6.2 Character Programming

The 5 characters per block are programmable via I²C bus using a 7 bit code which is identical with the ASCII code except for some of the special characters. The codes are placed in a character RAM consisting of 45 cells. The size of the RAM is determined by the number of characters per block (5) and the maximum number of PIP pictures (9 in multi PIP display modes). The character codes can be transmitted in two ways: each of the 45 RAM locations can be reached separately by its 7 bit address or the RAM can be

written consecutively starting at an arbitrarily chosen position. In this case the RAM address is increased automatically.

The 7 bit address consists of two parts: the 4 MSB's are used to choose one of the partial pictures and the 3 LSB's to select one of the 5 characters per block.

2.6.3 Character and Character Background Luminance

The chrominance components of the characters and their background box always have the value 0. The luminance values are programmable via I²C bus according to the following tables (100 IRE corresponds to the full scale range of DAC input = integer value 63):

Character Luminance	IRE	Integer Value
0 0	60	38
0 1	70	44
1 0	80	50
1 1	90	56

Character Background Luminance	IRE	Integer Value
0 0	10	6
0 1	20	12
1 0	30	19
1 1	40	25

2.6.4 Character Set

The following table shows the pixel matrices of the characters stored in the character ROM:

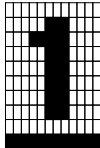
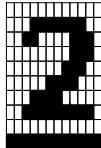
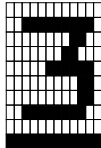
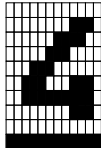
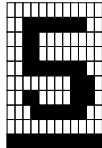
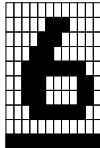
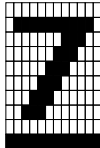
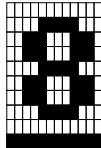
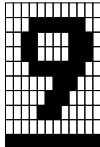
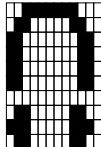
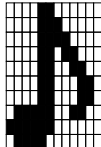
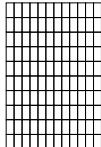
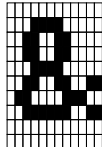
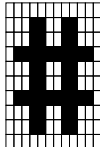
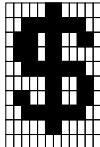
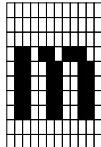
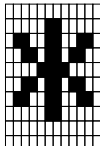
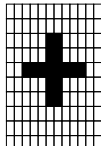
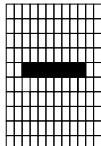
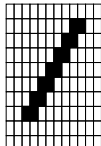
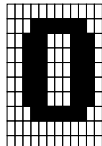
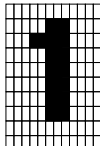
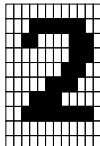
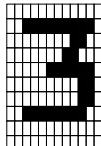
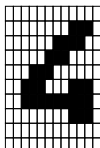
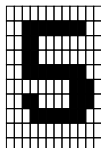
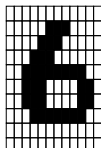
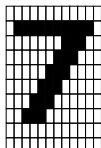
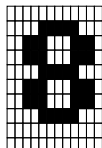
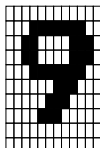
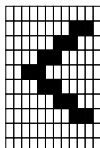
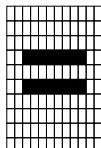
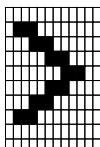
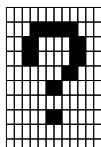
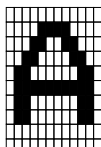
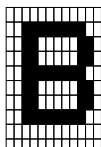
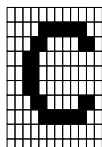
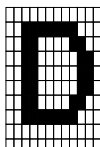
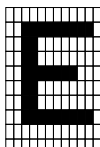
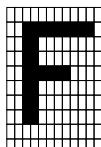
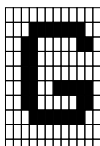
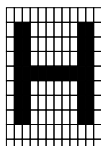
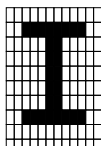
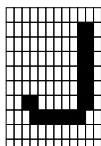
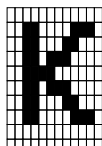
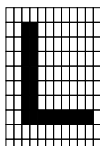
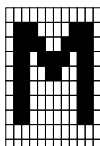
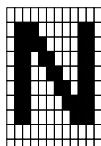
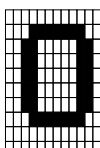
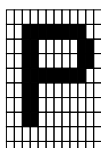
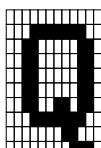
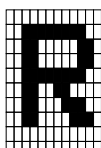
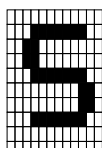
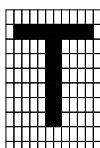
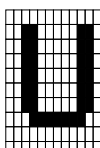
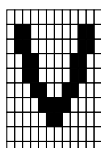
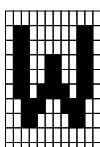
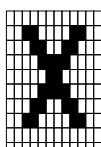
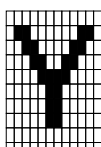
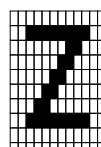
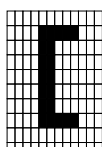
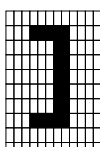
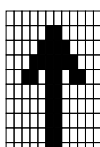
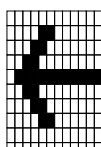
							
0000001=01	0000010=02	0000011=03	0000100=04	0000101=05	0000110=06	0000111=07	0001000=08
							
0001001=09	0001010=0A	0001011=0B	0100000=20	0100001=21	0100011=23	0100100=24	0100101=25
							
0101010=2A	0101011=2B	0101101=2D	0101111=2F	0110000=30	0110001=31	0110010=32	0110011=33
							
0110100=34	0110101=35	0110110=36	0110111=37	0111000=38	0111001=39	0111100=3C	0111101=3D
							
0111110=3E	0111111=3F	1000001=41	1000010=42	1000011=43	1000100=44	1000101=45	1000110=46
							
1000111=47	1001000=48	1001001=49	1001010=4A	1001011=4B	1001100=4C	1001101=4D	1001110=4E
							
1001111=4F	1010000=50	1010001=51	1010010=52	1010011=53	1010100=54	1010101=55	1010110=56
							
1010111=57	1011000=58	1011001=59	1011010=5A	1011011=5B	1011101=5D	1011110=5E	1011111=5F

2.7 Numerical PLL

A numerical PLL circuit supplies a clock of about 27 MHz with high stability. The nominal quartz frequency is 20.48 MHz. The generated clock is locked to the parent horizontal synchronization pulses. Its frequency varies with the frequency of this signal. Four different characteristics of the PLL behaviour can be chosen to handle synchronization signals from various sources (PLLTC).

If the PLL is switched off an external 13.5 or 27 MHz parent line locked clock can be fed to the IC. Using up to three SDA 9189X ICs in the same application only one quartz is necessary.

2.8 I²C Bus

2.8.1 I²C Bus Addresses

Three different I²C bus addresses are programmable via pin ADR.

Pin ADR	Address
Low level (V_{SS} or V_{SSA})	1 1 0 1 0 1 1
Mid level (open)	1 1 0 1 1 1 0
High level (V_{DD} or V_{DDA})	1 1 0 1 1 1 1

2.8.2 I²C Bus Receiver Format

S	Address	0	A	Subaddress	A	Data Byte	A	XXX	A	P
---	---------	---	---	------------	---	-----------	---	-----	---	---

S: Start condition

A: Acknowledge

P: Stop condition

Only write operation is possible. An automatical address increment function is implemented.

2.8.3 I²C Bus Commands

Overview

Subadd. (Hex.)	Data Byte							
	D7	D6	D5	D4	D3	D2	D1	D0
00	0	0	FREEZE	PLLOFF	READ27	LINEDBL	FRAME	PIPON
01	0	SELDEL3	SELDEL2	SELDEL1	SELDEL0	VERBLK	POSHOR9	POSHOR8
02	POSHOR7	POSHOR6	POSHOR5	POSHOR4	POSHOR3	POSHOR2	POSHOR1	POSHOR0
03	POSVER7	POSVER6	POSVER5	POSVER4	POSVER3	POSVER2	POSVER1	POSVER0
04	0	PIPLIN1	PIPLIN0	PIPMOD4	PIPMOD3	PIPMOD2	PIPMOD1	PIPMOD0
05	WRPOS3	WRPOS2	WRPOS1	WRPOS0	PMOD1	PMOD0	IMOD1	IMOD0
06	0	0	BCKCOL	HSIDEL4	HSIDEL3	HSIDEL2	HSIDEL1	HSIDEL0
07	AMSEC	0	0	VSIDEL4	VSIDEL3	VSIDEL2	VSIDEL1	VSIDEL0
08	0	0	0	VSPDEL4	VSPDEL3	VSPDEL2	VSPDEL1	VSPDEL0
09	CON3	CON2	CON1	CON0	FRY5	FRY4	FRY3	FRY2
0A	FRV5	FRV4	FRV3	FRV2	FRU5	FRU4	FRU3	FRU2
0B	INFR	SELMOD1	SELMOD0	FRWIDV1	FRWIDV0	FRWIDH2	FRWIDH1	FRWIDH0
0C	0	0	0	0	MAT1	MAT0	CHRIPI	OUTFOR
0D	0	PLLTC1	PLLTC0	0	0	0	0	0
0E	PEDESTV3	PEDESTV2	PEDESTV1	PEDESTV0	PEDESTU3	PEDESTU2	PEDESTU1	PEDESTU0
0F	DACONST	DACONDE	ANCON5	ANCON4	ANCON3	ANCON2	ANCON1	ANCON0
10	BCKFR	BCKY1	BCKY0	BCKU5	BCKU4	BCKV5	BCKV4	BCKON
11	WIPEON	WIPESP1	WIPESP0	BLKDEL3	BLKDEL2	BLKDEL1	BLKDEL0	FRCOL
12	0	CHARY1	CHARY0	CHBCKY1	CHBCKY0	CHARBCK	CHARRES	OSDON
13	0	CHARLOC6	CHARLOC5	CHARLOC4	CHARLOC3	CHARLOC2	CHARLOC1	CHARLOC0
14	0	CHAR6	CHAR5	CHAR4	CHAR3	CHAR2	CHAR1	CHAR0

After switching on the IC the data bytes of all registers are set to “0”, the bit PLLOFF is set to “1”.

Detailed Description

Subaddress 00

Bit	Name	Function
D5	FREEZE	0: moving picture 1: freeze picture
D4	PLLOFF	0: internal PLL on 1: internal PLL off (external clock generation)
D3	READ27	0: PIP display with single read frequency (13.5 MHz) 1: PIP display with double read frequency (27 MHz)
D2	LINEDBL	0: each line of the PIP memory is read once (normal operation) 1: each line of the PIP memory is read twice (line doubling for progressive scan conversion systems in parent channel)
D1	FRAME	0: field mode display 1: frame mode display (if possible)
D0	PIPON	0: PIP insertion off 1: PIP insertion on

Subaddress 01

Bit	Name	Function
D6 ... D3	SELDEL	delay of output signal at pin SEL (– 8 ... + 7 periods of read frequency clock, programmable in 2's complement code)
D2	VERBLK	0: clamping level at DAC outputs only during line-blanking intervals 1: clamping level at DAC outputs during line-blanking intervals and field-blanking intervals (16 complete lines following the vertical synchronization pulse of the parent channel)
D1 ... D0	POSHOR	2 MSBs of POSHOR (see subaddress 02)

Detailed Description (cont'd)

Subaddress 02

Bit	Name	Function
D7 ... D0	POSHOR	horizontal position of PIP picture (in steps of 1 pixel) Remark: the 2 MSBs of POSHOR are located at Subaddress 01, bits D0 and D1 Warning: positions outside the active area of the parent picture are possible. Allowed area see at description Display Position.

Subaddress 03

Bit	Name	Function
D7 ... D0	POSVER	vertical position of PIP picture (in steps of 1 line) Warning: positions outside the active area of the parent picture are possible. Allowed area see at description Display Position.

Subaddress 04

Bit	Name	Function
D6 ... D5	PIPLIN	00: PIP display line standard according to parent signal 01: PIP display line standard according to inset signal 10: fixed PIP display line standard: 625 lines 11: fixed PIP display line standard: 525 lines
D4 ... D0	PIPMOD	display mode (8 single and 10 multi PIP display modes are available, see diagrams above)

Detailed Description (cont'd)

Subaddress 05

Bit	Name	Function
D7 ... D4	WRPOS	multi PIP display modes: selection of partial picture for writing (position number depends on the chosen display mode, see diagrams) single PIP display modes: WRPOS must be set to 0000
D3 ... D2	PMOD	00: automatic detection of line standard (parent signal) 01: fixed adjustment 625 lines 10: fixed adjustment 525 lines 11: freeze last line standard
D1 ... D0	IMOD	00: automatic detection of line standard (inset signal) 01: fixed adjustment 625 lines 10: fixed adjustment 525 lines 11: freeze last line standard

Subaddress 06

Bit	Name	Function
D5	BCKCOL	0: inset pictures visible (normal mode) 1: PIP picture filled with luminance value of the background color BCKY (see subaddress 10). The chrominance components are set to 0.
D4 ... D0	HSIDEL	delay of the horizontal synchronization pulse of the inset signal (in steps of 4 periods of 13.5 MHz clock) for the purpose of shifting the decimated part of a line.

Detailed Description (cont'd)

Subaddress 07

Bit	Name	Function
D7	AMSEC	0: unity amplification of decimation filters (normal mode) 1: amplification by a factor of 2 (SECAM signals without delay line in the chroma decoder)
D4 ... D0	VSIDEL	delay of vertical synchronization pulse of the inset signal (in steps of 32 periods of 13.5 MHz clock)

Subaddress 08

Bit	Name	Function
D4 ... D0	VSPDEL	delay of vertical synchronization pulse of the parent signal (in steps of 32 periods of the read clock with a frequency of 13.5 or 27 MHz)

Subaddress 09

Bit	Name	Function
D7 ... D4	CON	contrast adjustment of PIP picture (16 steps) with step sizes depending on IREF and external output resistors
D3 ... D0	FRY	luminance component of frame color (4 MSBs of 6 bits)

Subaddress 0A

Bit	Name	Function
D7 ... D4	FRV	chrominance component (R-Y) of frame color (4 MSBs of 6 bits)
D3 ... D0	FRU	chrominance component (B-Y) of frame color (4 MSBs of 6 bits)

Detailed Description (cont'd)

Subaddress 0B

Bit	Name	Function
D7	INFR	0: inner frame elements off 1: inner frame elements on
D6 ... D5	SELMOD	00: TTL output 01: open source output 10: open drain output
D4 ... D3	FRWIDV	vertical width of PIP frame (0 ... 3 lines)
D2 ... D0	FRWIDH	horizontal width of PIP frame (0 ... 7 pixels)

Subaddress 0C

Bit	Name	Function
D3	MAT1	0: NTSC RGB matrix (USA) 1: NTSC RBG matrix (Japan)
D2	MAT0	0: EBU RGB matrix 1: NTSC RGB matrix
D1	CHRPPI	0: non-inverted chrominance output signals + (B-Y), + (R-Y) 1: inverted chrominance output signals – (B-Y), – (R-Y)
D0	OUTFOR	0: format of output signals: Y, (B-Y), (R-Y) 1: format of output signals: R G B

Subaddress 0D

Bit	Name	Function
D6 ... D5	PLLTC	00: PLL loop filter: medium damping, low res. frequency 01: PLL loop filter: low damping, high res. frequency 10: PLL loop filter: high damping, low res. frequency 11: PLL loop filter: medium damping, high res. frequency

Detailed Description (cont'd)

Subaddress 0E

Bit	Name	Function
D7 ... D4	PEDESTV	4-bit pedestal value for chrominance component (R-Y) fed to corresponding DAC during line-blanking interval (2's complement code, - 8 to + 7 LSBs of DAC)
D3 ... D0	PEDESTU	4-bit pedestal value for chrominance component (B-Y) fed to corresponding DAC during line-blanking interval (2's complement code, - 8 to + 7 LSBs of DAC)

Subaddress 0F

Bit	Name	Function
D5 ... D0	ANCON	digital input value for DAC at output pin ANACON (2's complement code, all bits 0 = medium output voltage)
D6	DACONDE	set to 0
D7	DACONST	Changing from 0 to 1 starts automatic adjustment of OUT1 ... 3 output current

Detailed Description (cont'd)

Subaddress 10

Bit	Name	Function
D7	BCKFR	0: color of full screen background insertion according to the settings of BCKY, BCKU, and BCKV 1: color of full screen background insertion identical with the frame color
D6 ... D5	BCKY	00: luminance value of full screen background: 20 IRE 01: luminance value of full screen background: 30 IRE 10: luminance value of full screen background: 40 IRE 11: luminance value of full screen background: 50 IRE
D4 ... D3	BCKU	2 MSBs of chrominance component (B-Y) of full screen background (remaining bits = 0)
D2 ... D1	BCKV	2 MSBs of chrominance component (R-Y) of full screen background (remaining bits = 0)
D0	BCKON	0: full screen background insertion off 1: full screen background insertion on

Subaddress 11

Bit	Name	Function
D7	WIPEON	0: wipe in/out function off 1: wipe in/out function on
D6 ... D5	WIPESP	period for opening and closing the PIP window 4 values from 1/3 to 4/3 of a second can be selected (WIPESP = 00 corresponds to the shortest time period).
D4 ... D1	BLKDEL	delay to adjust line-blanking interval (parent channel, full background insertion) in steps of 8 periods of 13.5 MHz/27 MHz clock
D0	FRCOL	0: inset pictures visible (normal mode) 1: PIP picture filled with frame color

Detailed Description (cont'd)

Subaddress 12

Bit	Name	Function
D6 ... D5	CHARY	00: luminance value of character 60 IRE 01: luminance value of character 70 IRE 10: luminance value of character 80 IRE 11: luminance value of character 90 IRE
D4 ... D3	CHARBCKY	00: luminance value of character background: 10 IRE 01: luminance value of character background: 20 IRE 10: luminance value of character background: 30 IRE 11: luminance value of character background: 40 IRE
D2	CHARBCK	0: character background insertion off 1: character background insertion on
D1	CHARRES	0: characters unchanged 1: all characters set to special character "blank"
D0	OSDON	0: on screen display of characters off 1: on screen display of characters on

Subaddress 13

Bit	Name	Function
D6 ... D0	CHARLOC	7-bit address of character RAM: 4 MSBs address partial pictures (0 to 8 max.), 3 LSBs address character position in block (0 to 4, from left to right)

Subaddress 14

Bit	Name	Function
D6 ... D0	CHAR	character code to select 1 of 64 available characters

3 Absolute Maximum Ratings

Parameter	Symbol	Limit Values		Unit	Remark
		min.	max.		
Ambient temperature		0	70	°C	
Storage temperature		- 55	125	°C	
Junction temperature			125	°C	
Soldering temperature			260	°C	
Soldering time			10	s	
Input voltage		- 1	7	V	
Output voltage		- 1	7	V	
Supply voltages		- 1	7	V	
Supply voltage differentials		- 0.25	0.25	V	
Total power dissipation			900	mW	
ESD protection		- 1	1	kV	MIL STD 883C method 3015.6 100 pF, 1500 Ω supply pins connected to ground
Latch-up protection		- 100	100	mA	except analog outputs, XQ

All voltages listed are referenced to ground (0 V, V_{SS}) except where noted.

Absolute Maximum Ratings are those values beyond which damage to the device may occur. Functional operation under these conditions or at any other condition beyond those indicated in the operational sections of this specification is not implied.

4 Recommended Operating Conditions

Parameter	Symbol	Limit Values			Unit	Remark
		min.	typ.	max.		
Supply voltages	V_{DDxx}	4.75	5	5.5	V	
Ambient temperature	T_A	0	25	70	°C	

All TTL Inputs

Low-level input voltage	V_{IL}	- 1		0.8	V	
High-level input voltage	V_{IH}	2.0		6	V	

Inset Horizontal Sync TTL Input: HSI

(All values are referred to the corresponding min (V_{IH}) and max (V_{IL}))

Horizontal frequency		14.53		16.72	kHz	
Signal rise time				15	ns	
Signal high time		100			ns	
Signal low time		900			ns	
Signal setup time		15			ns	LH transition of LL3I

Inset Vertical Sync TTL Input: VSI

(All values are referred to the corresponding min (V_{IH}) and max (V_{IL}))

Signal high time		200			ns	
Signal low time		200			ns	

Line Locked Clock Inset Picture TTL Input: LL3I

(All values are referred to the corresponding min (V_{IH}) and max (V_{IL}))

Signal period time		68		80	ns	
Signal rise time				5	ns	
Signal fall time				4	ns	
Signal high time		28			ns	
Signal low time		30			ns	

Recommended Operating Conditions (cont'd)

Parameter	Symbol	Limit Values			Unit	Remark
		min.	typ.	max.		

Digital Data TTL Inputs: YIN, UVIN**(All values are referred to the Corresponding min (V_{IH}) and max (V_{IL}))**

Signal setup time		15			ns	LH transition of LL3I
Signal hold time		5			ns	LH transition of LL3I

Parent Horizontal Sync TTL Inputs: HSP**(All values are referred to the corresponding min (V_{IH}) and max (V_{IL}))**

Sync frequency in single frequency display mode		14.53		16.72	kHz	quartz frequency 20.48 MHz
		15		17.19	kHz	quartz frequency 21.09 MHz
Sync frequency in double frequency display mode		29.06		33.44	kHz	quartz frequency 20.48 MHz
		30		34.38	kHz	quartz frequency 21.09 MHz
Signal rise time				100	ns	noisefree transition
Signal high time		100			ns	
Signal low time		900			ns	

Parent Vertical Sync TTL Input VSP**(All values are referred to the corresponding min (V_{IH}) and max (V_{IL}))**

Signal high time		200			ns	
Signal low time		200			ns	

Recommended Operating Conditions (cont'd)

Parameter	Symbol	Limit Values			Unit	Remark
		min.	typ.	max.		

Quartz / Ceramic Resonator

Recommended frequency		20.25	20.48	21.3	MHz	21.09 MHz for MUSE
Series resistance				10	W	$C_1, C_2 \leq 33$ pF
				20	W	$C_1, C_2 \leq 22$ pF
				30	W	$C_1, C_2 \leq 15$ pF
				40	W	$C_1, C_2 \leq 10$ pF

Optional TTL Clock Input: XIN (All values are referred to min (V_{IH}) and max (V_{IL}))

Clock input cycle time		35		40	ns	external line locked 27 MHz clock (I ² C: internal PLL off)
Clock input rise time				5	ns	
Clock input fall time				5	ns	
Clock input low time		10			ns	
Clock input high time		10			ns	

Fast I²C Bus (All values are referred to min (V_{IH}) and max (V_{IL}))

This specification of the bus lines need not be identical with the I/O stages specification because of optional series resistors between bus lines and I/O pins.

SCL clock frequency	f_{SCL}			400	kHz	
Inactive time before start of transmission	t_{BUF}	1.3			μ s	
Setup time start condition	$t_{SU; STA}$	0.6			μ s	
Hold time start condition	$t_{HD; STA}$	0.6			μ s	
SCL low time	t_{LOW}	1.3			μ s	
SCL high time	t_{HIGH}	0.6			μ s	

Recommended Operating Conditions (cont'd)

Parameter	Symbol	Limit Values			Unit	Remark
		min.	typ.	max.		
Setup time DATA	$t_{\text{SU; DAT}}$	100			ns	
Hold time DATA	$t_{\text{HD; DAT}}$	0		0.9	μs	
SDA/SCL rise/fall times	$t_{\text{R}}, t_{\text{F}}$	20 + \$		300	ns	\$ = $0.1C_{\text{b}}/\text{pF}$
Setup time stop condition	$t_{\text{SU; STO}}$	0.6			μs	
Capacitive load/bus line	C_{b}			400	pF	

I²C Bus Inputs/Output: SDA, SCL

High-level input voltage	V_{IH}	3 V		$V_{\text{DD}} + 0.5 \text{ V}$	1	also for SDA/SCL input stages
Low-level input voltage	V_{IL}	- 0.5 V		1.5	V	
Spike duration at inputs		0	0	50	ns	
Low-level output current	I_{OL}			6	mA	

I²C Bus Three Level Input ADR

High-level input voltage	V_{IH}	3.5		6	V	
Low-level input voltage	V_{IL}	- 1		0.8	V	
Medium-level voltage	V_{IM}	open input, see Characteristics				

Digital to Analog Converters (6 bit) OUT1, OUT2, OUT3

Full range output voltage	V_{OFR}		1	2	V	peak to peak
Reference resistance	R_{REF1}	4.2	5.1	6.3	k Ω	no contrast adjustment via I ² C bus; bits CON = 0000
Reference resistance	R_{REF2}	6.0	6.8	7.5	k Ω	contrast adjustment via I ² C bus

5 Characteristics

(Assuming Recommended Operating Conditions)

Note: The listed characteristics are ensured over the operating range of the integrated circuit unless restricted to nominal operating conditions.
(All voltages refer to V_{SS}).

Parameter	Symbol	Limit Values		Unit	Remark
		min.	max.		
Average total supply current	I_{DDtot}		160	mA	$I_{DDtot} = I_{DD} + I_{DDA}$ Note: The maxima do not necessarily coincide
Average digital supply current	I_{DD}		tbF	mA	
Average analog supply current	I_{DDA}		tbF	mA	
All digital Inputs (TTL, I ² C)					
Input capacitance	C_I		7	pF	not tested
Input leakage current		- 10	10	μA	including leakage current of SDA output stage, not pin XIN; $V = 0 \dots 5 \text{ V}$
Input leakage current		- 0.4	0.4	mA	Pin XIN; $V = 0 \dots 5 \text{ V}$

Output SEL

High-level output voltage	V_{OH}	2.4 V	V_{DD}	1	$I_{OH} = - 200 \mu\text{A}$ SELMOD = 00 or 01
High-level output voltage	V_{OH}	1.5 V	V_{DD}	1	$I_{OH} = - 4.5 \text{ mA}$ SELMOD = 00 or 01
Low-level output voltage	V_{OL}	0	0.4	V	$I_{OL} = 1.6 \text{ mA}$ SELMOD = 00 or 10
Low-level output voltage	V_{OL}	0	1	V	$I_{OL} = 5 \text{ mA}$ SELMOD = 00 or 10
Leakage current		- 10		μA	$V_O = 0 \text{ V} \dots V_{DD}$

Characteristics (cont'd)

Parameter	Symbol	Limit Values		Unit	Remark
		min.	max.		
Output capacitance			7	pF	not tested

I²C Bus Inputs: SDA/SCL

Schmitt trigger hysteresis	V_{hys}	0.2		V	not tested
----------------------------	------------------	-----	--	---	------------

I²C Bus Input/Output: SDA (Referenced To SCL; Open Drain Output)

Low-level output voltage	V_{OL}		0.4	V	$I_{\text{OL}} = 3 \text{ mA}$
Low-level output voltage	V_{OL}		0.6	V	$I_{\text{OL}} = \text{max}$
Output fall time from min (V_{IH}) to max (V_{IL})	t_{OF}	$20 + 0.1 C_{\text{b}}/\text{pF}$	250	ns	$10 \text{ pF} \leq C_{\text{b}} \leq 400 \text{ pF}$

I²C Bus Three-Level Input ADR

Differential input resistor	R_{IN}	6	16	k Ω	
-----------------------------	-----------------	---	----	------------	--

Digital to Analog Converters (6 bit): Current Source Outputs OUT1, OUT2, OUT3. (I²C: Contrast bits set to zero unless otherwise noted)

D.C. diff. linearity error	DLE	- 0.5	0.5	LSB	$R_{\text{REF}} = 5.1 \text{ k}\Omega$
Full range output current	I_{O}	tbF	tbF	mA	$V_{\text{DDA}} = \text{nom}, T_{\text{A}} = \text{nom},$ $R_{\text{REF}} = 5.1 \text{ k}\Omega,$ $R_{\text{L}} = 560 \Omega,$ after adjustment
Output voltage ($V_{\text{O}} \sim 1.6 \times V_{\text{DDA}} \times R_{\text{L}}/R_{\text{REF}}$)	V_{O}	tbF	tbF	V	$T_{\text{A}} = \text{nom}, R_{\text{L}} = 560 \Omega$ $R_{\text{REF}} = 5.1 \text{ k}\Omega$
Tracking		- 3	3	%	$V_{\text{DDA}} = \text{nom}, T_{\text{A}} = \text{nom},$ $R_{\text{REF}} = 5.1 \text{ k}\Omega,$ $R_{\text{L}} = 560 \Omega$
Contrast increase		30		%	$V_{\text{DDA}} = \text{nom}, T_{\text{A}} = \text{nom},$ $R_{\text{L}} = 560 \Omega,$ $R_{\text{REF}} = 6.8 \text{ k}\Omega,$ contrast bits change from 0000 to 1111

Characteristics (cont'd)

Parameter	Symbol	Limit Values		Unit	Remark
		min.	max.		

Static Digital to Analog Converter (6 bit): Analog Voltage Output ANACON

D.C. diff. linearity error	DLE	- 1	1	LSB	
Low-level output voltage	V_{OL}	0.3	0.7	V	$R_L \geq 10 \text{ k}\Omega$
High-level output voltage	V_{OH}	$V_{DDA} - 0.5 \text{ V}$	V_{DDA}	1	$R_L \geq 100 \text{ k}\Omega$
High-level output voltage	V_{OH}	$V_{DDA} - 0.9 \text{ V}$	V_{DDA}	1	$R_L \geq 10 \text{ k}\Omega$

6 Application Information

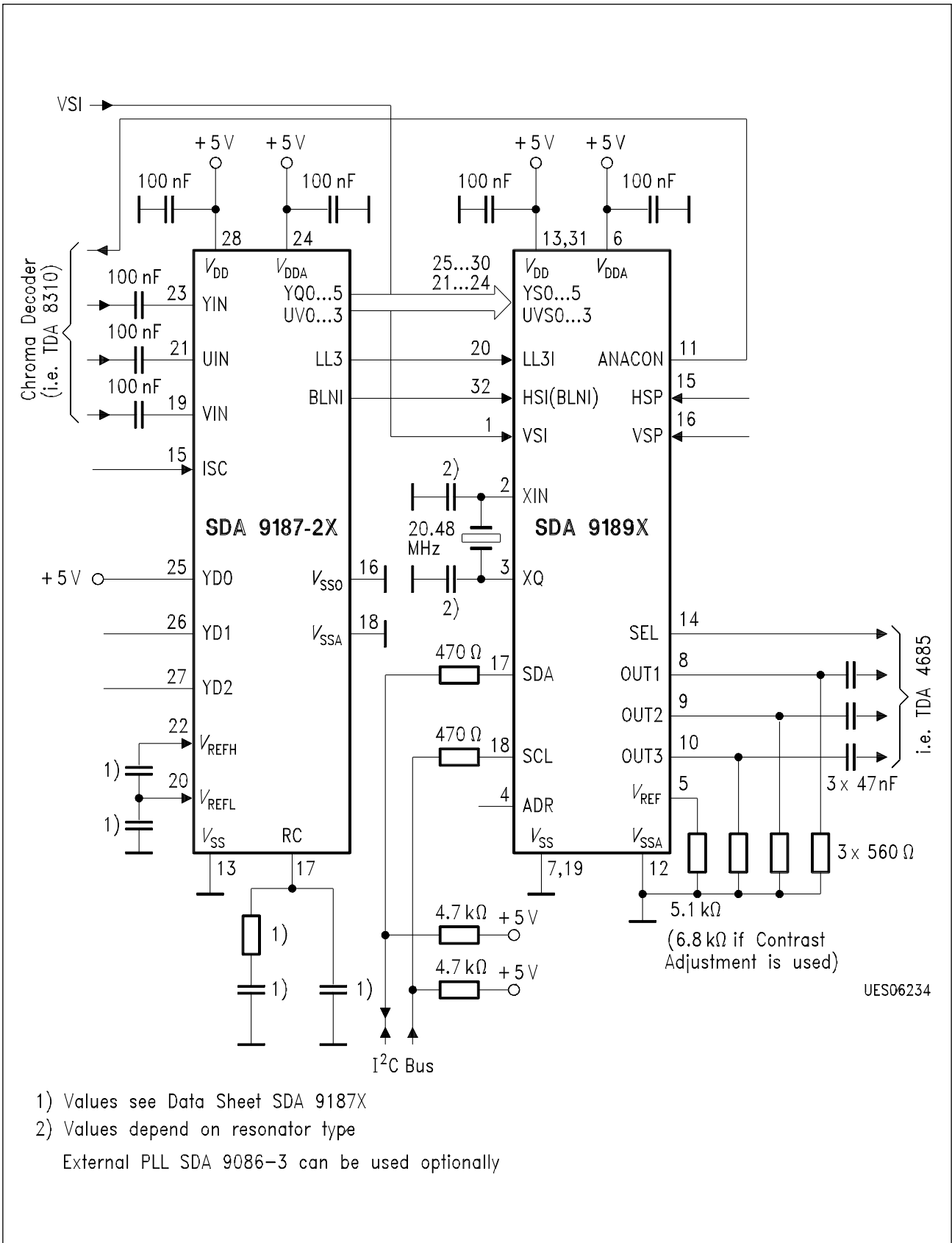

UES06234

7 Waveforms

7.1 Phase Relation of Sync Pulses at Frame Mode

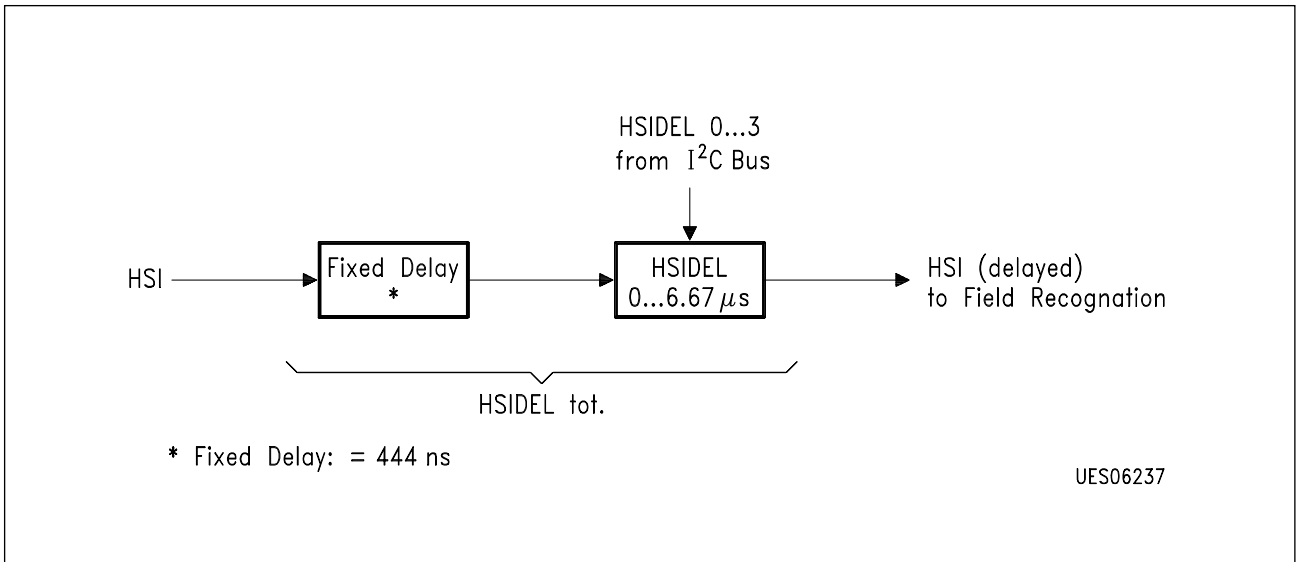

Signal Flow of the Horizontal Synchronization (Insert Part)

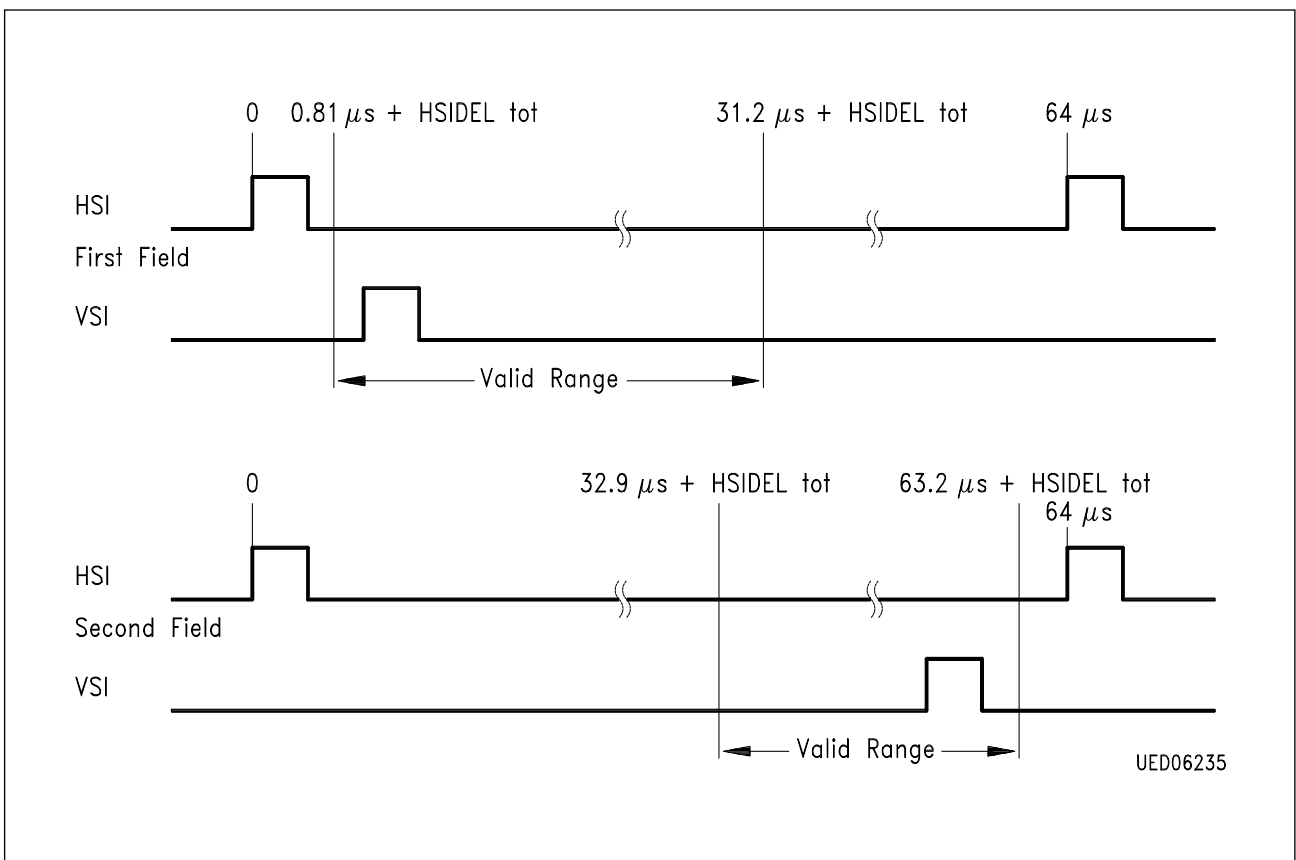

Allowed Phase Relation of the Horizontal/Vertical Sync Pulses (Insert Channel) if VSIDEL 0:4 = 0000

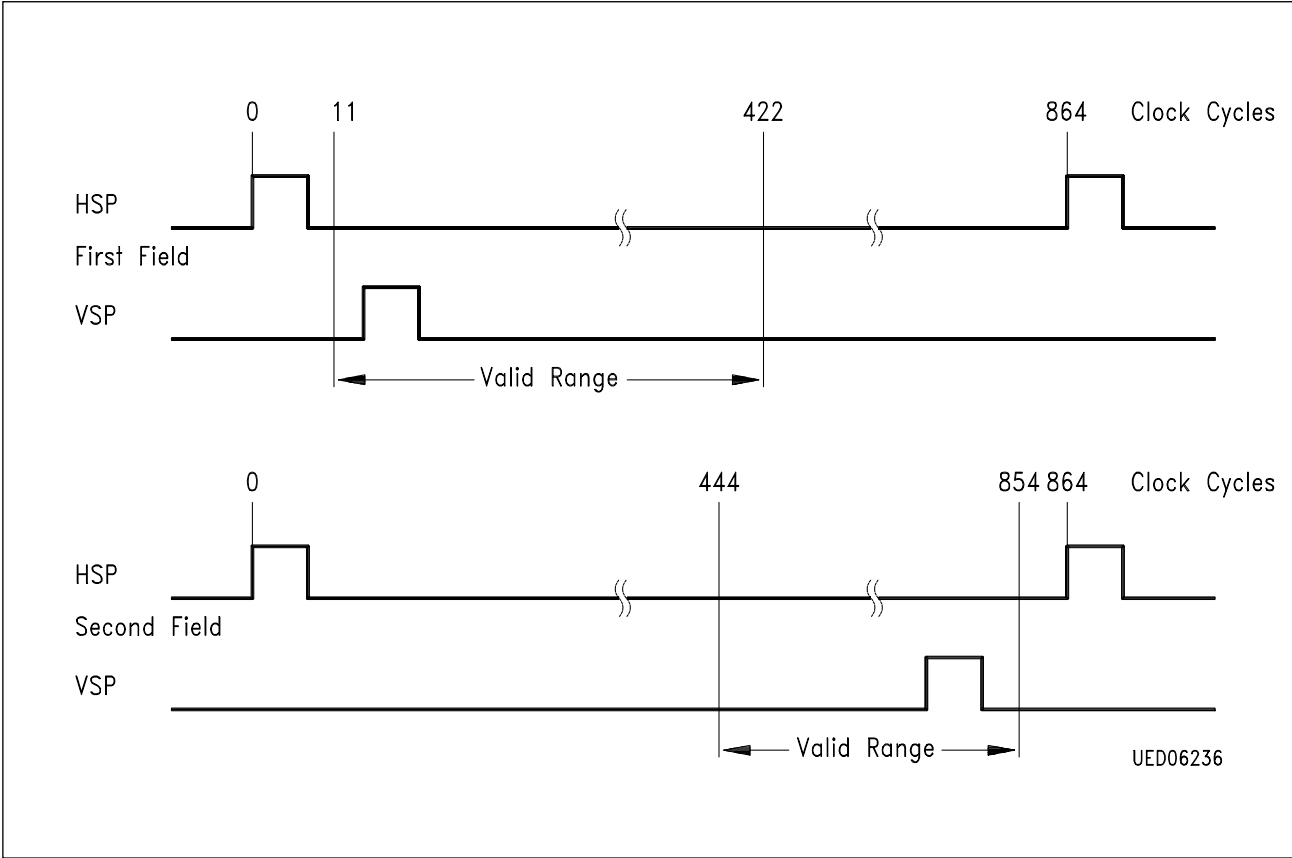

Allowed Phase Relation of the Horizontal/Vertical Sync Pulses (Parent Channel) if VSPDEL 0:4 = 0000

8 Package Outlines

Plastic Package, P-DSO-32-2 (SMD)
(Plastic Dual Small Outline Package)

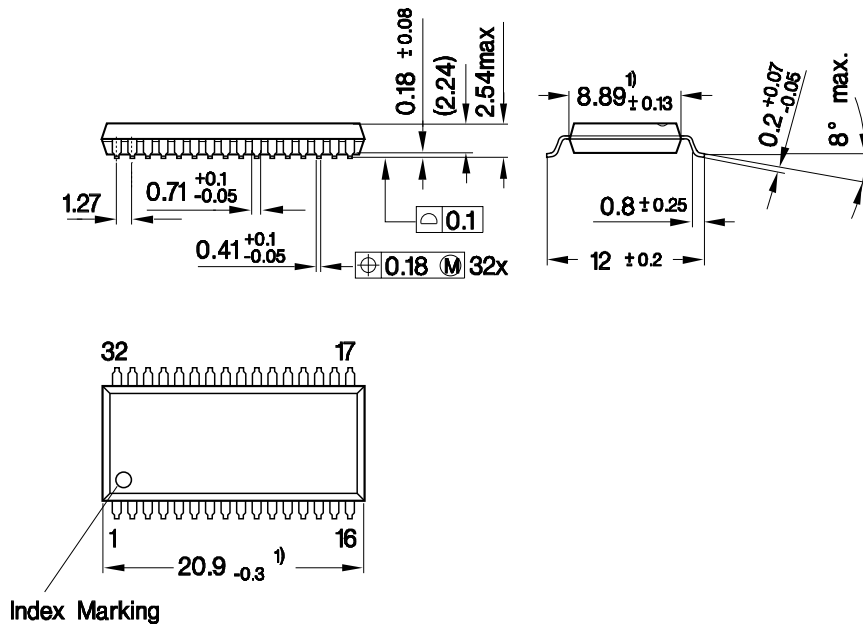

1) Does not include plastic or metal protrusion of 0.25 max. per side

GPS05697

Sorts of Packing

Package outlines for tubes, trays etc. are contained in our Data Book "Package Information"

SMD = Surface Mounted Device

Dimensions in mm