

TOSHIBA LED Lamp

TLWK1100B(T11)

Unit: mm

Panel Circuit Indicator

- Surface-mount devices
- 3.2 (L) × 2.9 (W) × 1.9 (H) mm
- LED chip + phosphor
- Luminous intensity : $I_v = 1500$ mcd (typ.) @20mA
- Color: White
- $T_{opr} / T_{stg} = -40$ to 100°C
- Applications: automotive use, backlighting etc.
- Standard embossed tape packing: T11 (2000/reel)
8-mm tape reel

Color and Material

Product Name	Color	Material
TLWK1100B	White	InGaN

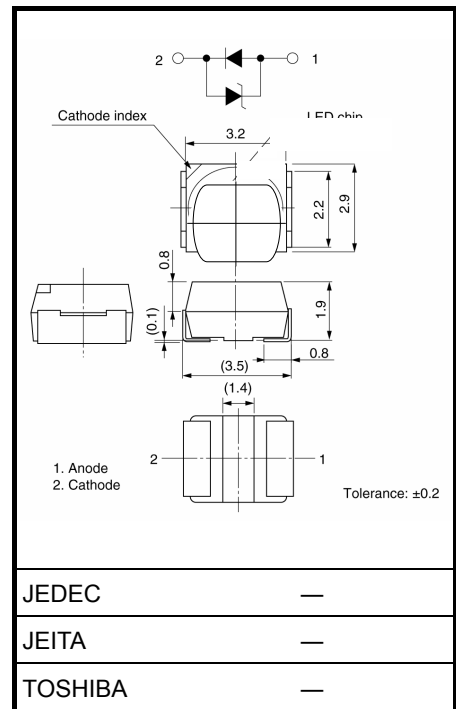

Absolute Maximum Ratings ($T_a = 25^{\circ}\text{C}$)

Weight: 0.035 g (typ.)

Characteristics	Symbol	Rating	Unit
Forward Current (Note 1)	I_F	30	mA
Power Dissipation	P_D	114	mW
Operating Temperature	T_{opr}	-40~100	$^{\circ}\text{C}$
Storage Temperature	T_{stg}	-40~100	$^{\circ}\text{C}$

Note: Using continuously under heavy loads (e.g. the application of high temperature/current/voltage and the significant change in temperature, etc.) may cause this product to decrease in the reliability significantly even if the operating conditions (i.e. operating temperature/current/voltage, etc.) are within the absolute maximum ratings.

Please design the appropriate reliability upon reviewing the Toshiba Semiconductor Reliability Handbook ("Handling Precautions"/"Derating Concept and Methods") and individual reliability data (i.e. reliability test report and estimated failure rate, etc).

Note 1: Forward current derating

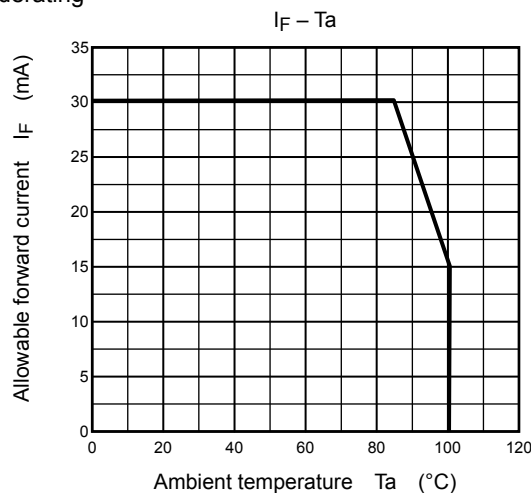

Electrical Characteristics (Ta = 25°C)

Characteristics	Symbol	Test condition	Min.	Typ.	Max.	Unit
Forward Voltage	V_F	$I_F = 20 \text{ mA}$	2.6	3.2	3.8	V
Reverse Voltage	V_R	$I_R = 10 \text{ mA}$	—	0.75	—	V

Optical Characteristics (Ta = 25°C)

Characteristics	Symbol	Test condition	Min.	Typ.	Max.	Unit
Chromaticity	C_x	$I_F = 20 \text{ mA}$	(Note 2)			—
	C_y	$I_F = 20 \text{ mA}$	(Note 2)			—
Luminous Intensity (Note 3)	I_V	$I_F = 20 \text{ mA}$	1000	1500	2000	mcd

Note 2: The product is tested at the following chromaticity coordinate groups.

Test conditions: $I_F=20\text{mA}$, $T_a=25^\circ\text{C}$

Accuracy: ± 0.01

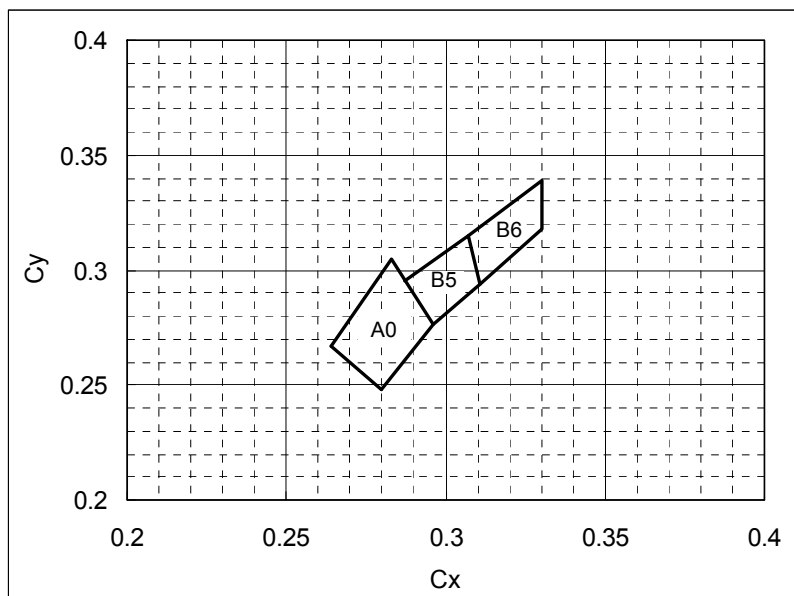

	A0			
C_x	0.280	0.296	0.283	0.264
C_y	0.248	0.276	0.305	0.267

	B5			
C_x	0.296	0.311	0.307	0.287
C_y	0.276	0.294	0.315	0.295

	B6			
C_x	0.311	0.330	0.330	0.307
C_y	0.294	0.318	0.339	0.315

Note 3: I_V rank classification

Test conditions: $I_F=20\text{mA}$, $T_a=25^\circ\text{C}$

Product name	Luminous intensity I_V			
	min	typ	max	I_F
TLWK1100B(T11)	1000	1500	2000	20
WA1	1000	—	1600	
WA2	1250	—	2000	
Unit	mcd			mA

The specification on the above table is used for I_V classification of LEDs in Toshiba facility. Each reel includes the same rank LEDs. Let the delivery ratio of each rank be unquestioned.

The cautions

- The product is sensitive to electrostatic and care must be fully taken when handling products. Particularly in the case that an over-voltage shall be applied, the overflowed energy may cause damage to or possibly result in destruction of the product. Buyer shall take absolutely secure countermeasures against electrostatic and surge when handling the product.
- The product is designed as a general display light source usage, and it has applied the measurement standard that matched with the sensitivity of human's eyes. Therefore, it is not intended for usage of functional application (ex. Light source for sensor, optical communication and etc) except general display light source.

TLWK1100B

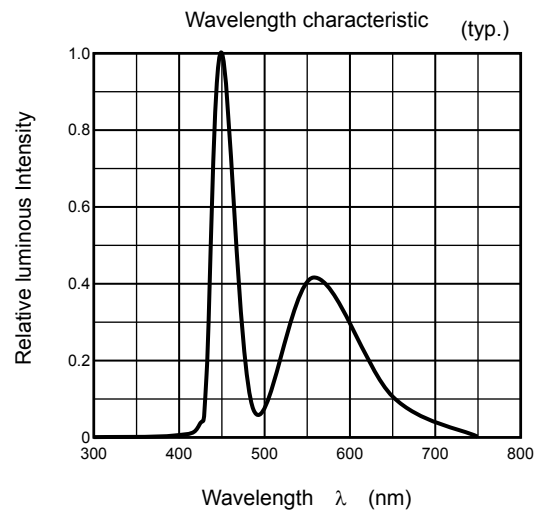
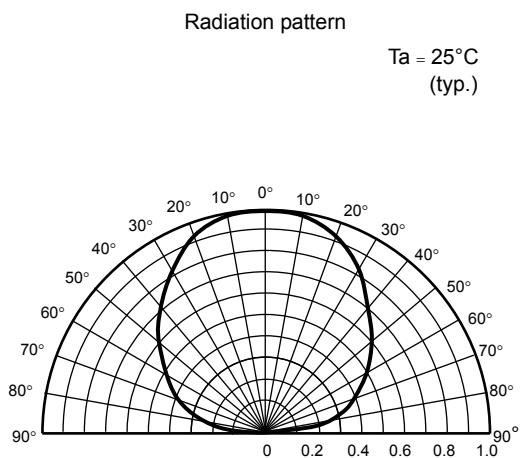
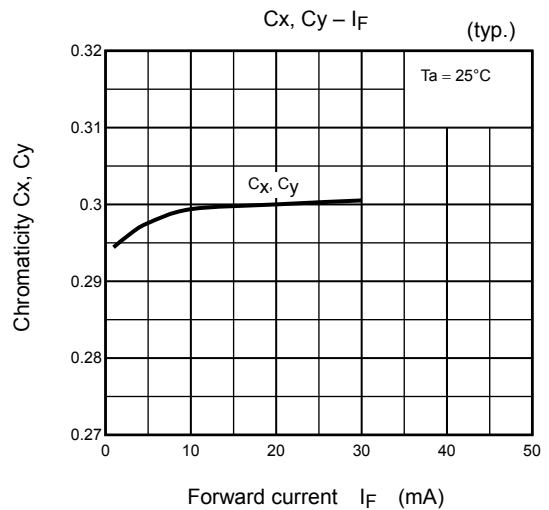
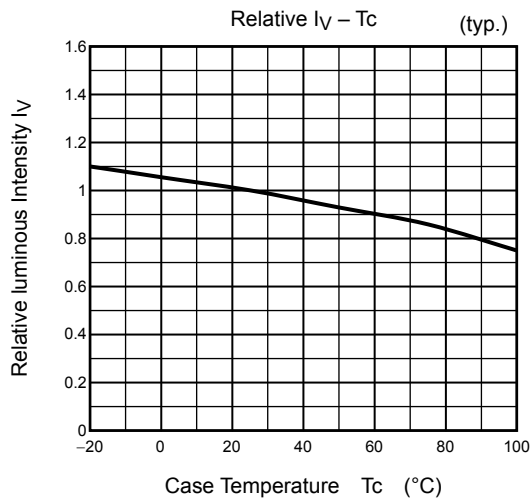
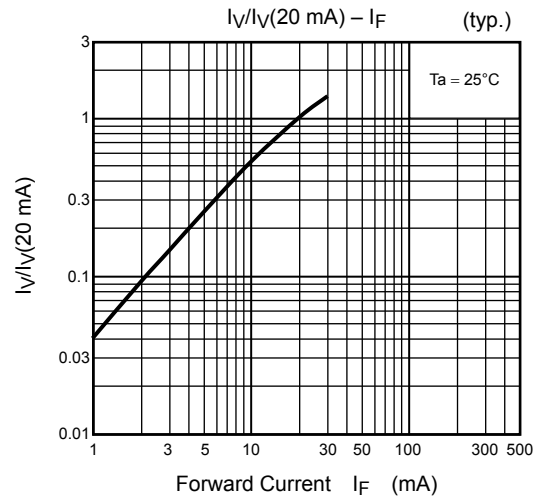
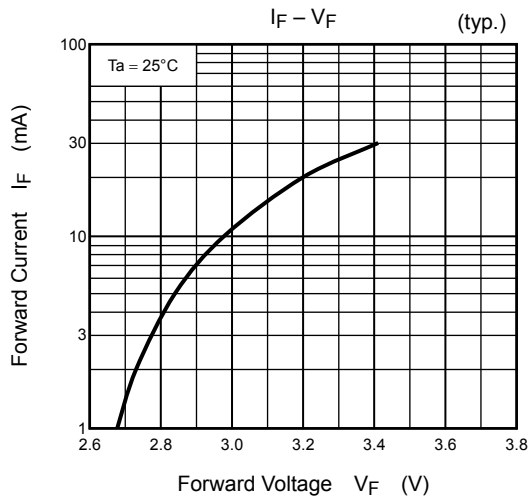

Packaging

This LED device is packed in an aluminum envelope with a silica gel and a moisture indicator to avoid moisture absorption. The optical characteristics of the device may be affected by exposure to moisture in the air before soldering and the device should therefore be stored under the following conditions:

1. This moisture proof bag may be stored unopened within 12 months at the following conditions.
 Temperature: 5°C~30°C
 Humidity: 90% (max)
2. After opening the moisture proof bag, the device should be assembled within 168 hours in an environment of 5°C to 30°C/60% RH or below.
3. If upon opening, the moisture indicator card shows humidity 30% or above (Color of indication changes to pink) or the expiration date has passed, the device should be baked in taping with reel.
 After baking, use the baked device within 72 hours, but perform baking only once.
 Baking conditions: 60±5°C, for 24 to 48 hours.
 Expiration date: 12 months from sealing date, which is imprinted on the label affixed.
4. Repeated baking can cause the peeling strength of the taping to change, then leads to trouble in mounting.
5. If the packing material of laminate would be broken, the hermeticity would deteriorate. Therefore, do not throw or drop the packed devices.

Mounting Method

Soldering

- Reflow soldering (example)

Temperature profile for Pb soldering (example)

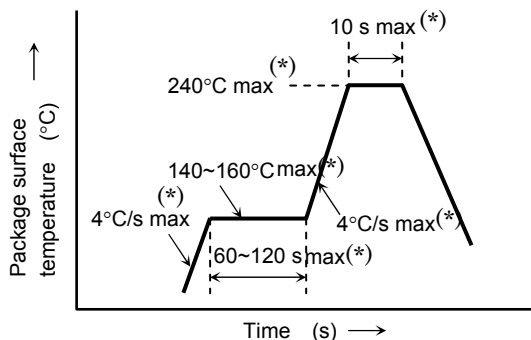

Temperature profile for Pb-free soldering (example)

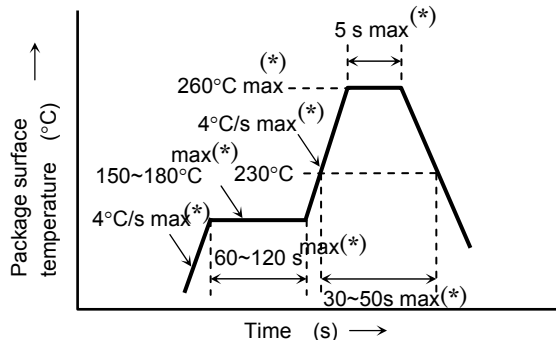

- The product is evaluated using above reflow soldering conditions. No additional test is performed exceed the condition (i.e. the condition more than (*)MAX values) as a evaluation. Please perform reflow soldering under the above conditions.
- Please perform the first reflow soldering with reference to the above temperature profile and within 168 h of opening the package.
- Second reflow soldering
 In case of second reflow soldering should be performed within 168 h of the first reflow under the above conditions.
 Storage conditions before the second reflow soldering: 30°C, 60% RH (max)
- Make any necessary soldering corrections manually.
 (only once at each soldering point)
 Soldering iron: 25 W
 Temperature : 300°C or less
 Time : within 3 s
- Do not perform wave soldering.

Recommended soldering pattern

Unit: mm

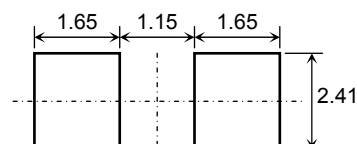

Cleaning

When cleaning is required after soldering, Toshiba recommends the following cleaning solvents. It is confirmed that these solvents have no effect on semiconductor devices in our dipping test (under the recommended conditions). In selecting the one for your actual usage, please perform sufficient review on washing condition, using condition and etc.

ASAHI CLEAN AK-225AES	: (made by ASAHI GLASS)
KAO CLEAN TROUGH 750H	: (made by KAO)
PINE ALPHA ST-100S	: (made by ARAKAWA CHEMICAL)
TOSHIBA TECHNOCARE (FRW-17, FRW-1, FRV-100)	: (made by GE TOSHIBA SILICONES)

Precautions when Mounting

Do not apply force to the plastic part of the LED under high-temperature conditions.
To avoid damaging the LED plastic, do not apply friction using a hard material.
When installing the PCB in a product, ensure that the device does not come into contact with other components.

Tape Specifications

1. Product number format

The type of package used for shipment is denoted by a symbol suffix after the product number. The method of classification is as below. (this method, however does not apply to products whose electrical characteristics differ from standard Toshiba specifications)

- (1) Tape Type: T11 (4-mm pitch)
- (2) Example

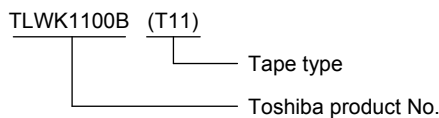

2. Tape dimensions

Symbol	Dimension	Tolerance
D	1.5	+0.1/-0
E	1.75	±0.1
P ₀	4.0	±0.1
t	0.3	±0.05
F	3.5	±0.05
D ₁	1.5	±0.1

Symbol	Dimension	Tolerance
P ₂	2.0	±0.05
W	8.0	±0.3
P	4.0	±0.1
A ₀	2.9	±0.1
B ₀	3.7	±0.1
K ₀	2.3	±0.1

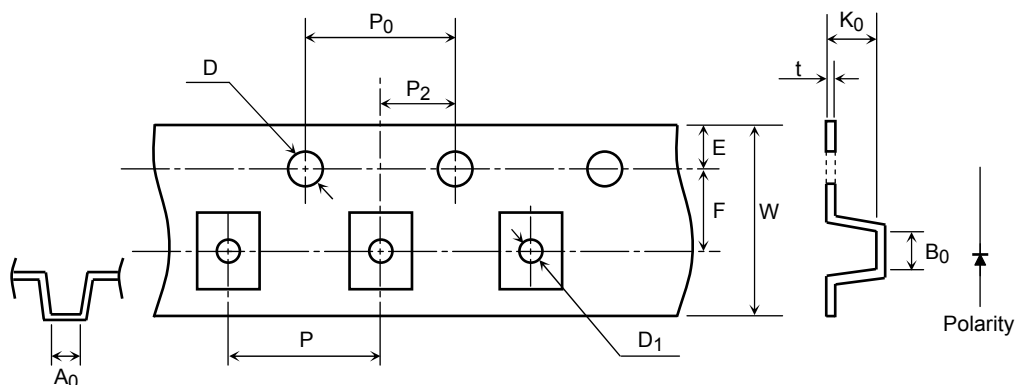

3. Reel dimensions

Unit: mm

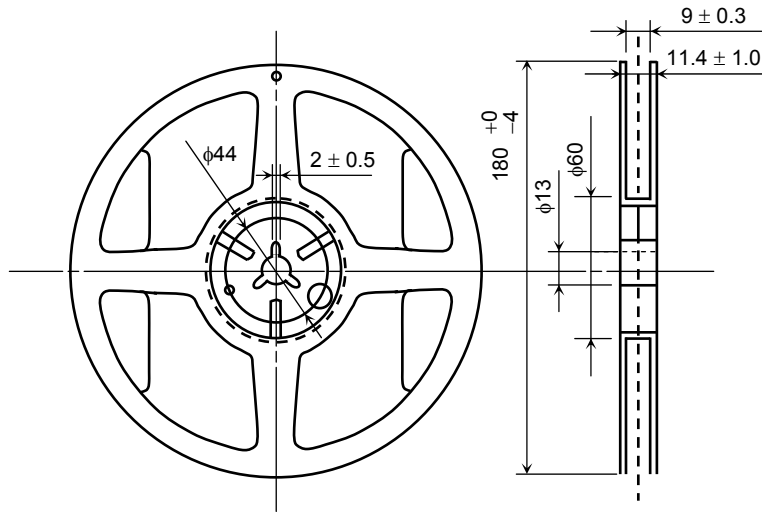

4. Leader and trailer sections of tape

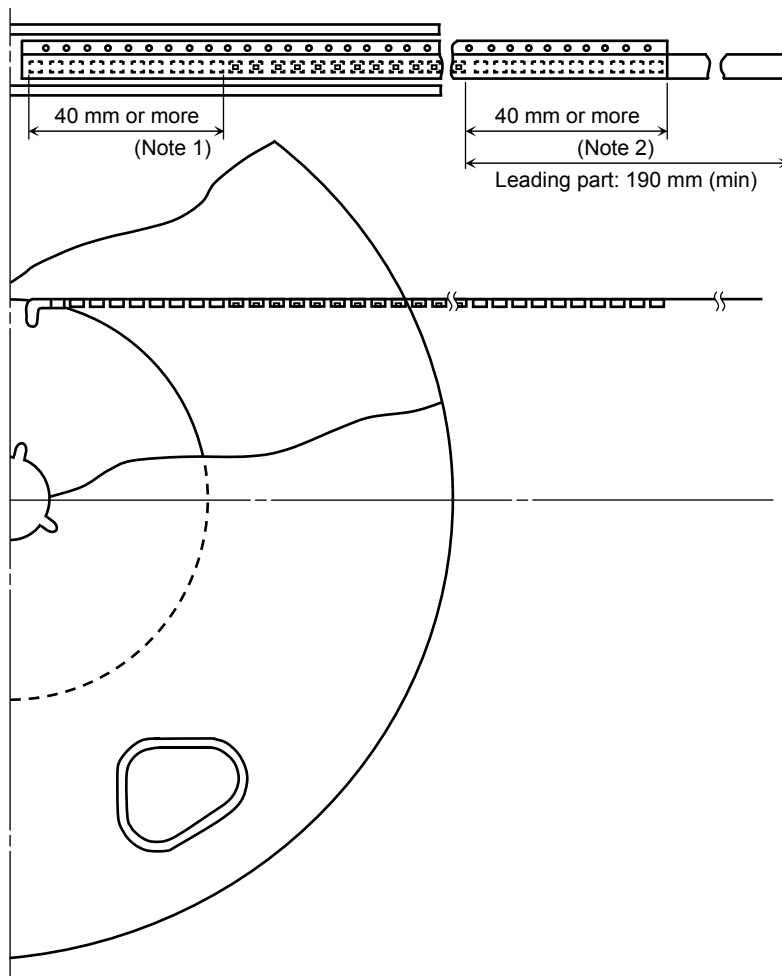

Note1: Empty trailer section

Note2: Empty leader section

5. Packing form

(1) Packing quantity

Reel	2,000 pcs
Carton	10,000 pcs

(2) Packing form: Each reel is sealed in an aluminum pack with silica gel.

6. Label format

(1) Label contents

Shipped products are mentioned the following contents.

P/N:

TYPE	TLWK1100B		
ADDC	(T11)	Q'TY	2,000 pcs



- 1) xxxxxx 2) xxxxxxxx 4) xxx 5) xxxx
- 3) (xxxxx)
- 6) E6SAG-0W0S6-07

7) Use under 5-30degC/60%RH within 168h

[[G]]/RoHS COMPATIBLE
Y3804xxxxxxxxxxxxxxxxx

SEAL DATE: xxxxxxxx
DIFFUSED IN JAPAN
ASSEMBLED IN JAPAN



Contents about Note section (Each example means the contents are different for each lot.)

Information for customers use	Information for Toshiba use
1) Lot code Example: 2707C2B	4) Management code Example: 715 32G
2) Key code Example: 12345678	5) Packing quantity Example: 2000 pcs
3) Rank symbol Example: B5WA1	6) Product information E6SAG-0W0S6-07
	7) Storage condition after opening Use under 5-30 degC/60%RH within 168h

(2) Label location

• Reel

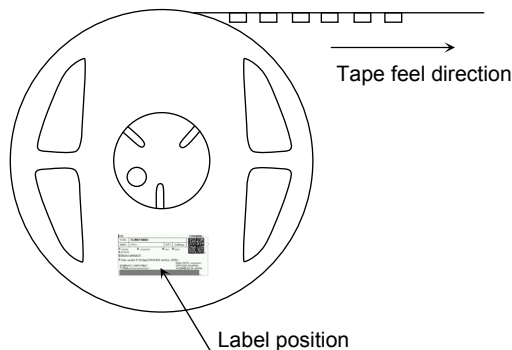

• Carton

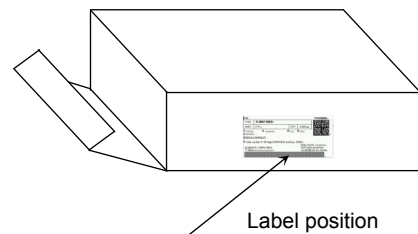

- The aluminum package in which the reel is supplied is also has the label attached to center of one side.

RESTRICTIONS ON PRODUCT USE

20070701-EN GENERAL

- The information contained herein is subject to change without notice.
- TOSHIBA is continually working to improve the quality and reliability of its products. Nevertheless, semiconductor devices in general can malfunction or fail due to their inherent electrical sensitivity and vulnerability to physical stress. It is the responsibility of the buyer, when utilizing TOSHIBA products, to comply with the standards of safety in making a safe design for the entire system, and to avoid situations in which a malfunction or failure of such TOSHIBA products could cause loss of human life, bodily injury or damage to property.
In developing your designs, please ensure that TOSHIBA products are used within specified operating ranges as set forth in the most recent TOSHIBA products specifications. Also, please keep in mind the precautions and conditions set forth in the "Handling Guide for Semiconductor Devices," or "TOSHIBA Semiconductor Reliability Handbook" etc.
- The TOSHIBA products listed in this document are intended for usage in general electronics applications (computer, personal equipment, office equipment, measuring equipment, industrial robotics, domestic appliances, etc.). These TOSHIBA products are neither intended nor warranted for usage in equipment that requires extraordinarily high quality and/or reliability or a malfunction or failure of which may cause loss of human life or bodily injury ("Unintended Usage"). Unintended Usage include atomic energy control instruments, airplane or spaceship instruments, transportation instruments, traffic signal instruments, combustion control instruments, medical instruments, all types of safety devices, etc.. Unintended Usage of TOSHIBA products listed in this document shall be made at the customer's own risk.
- The products described in this document shall not be used or embedded to any downstream products of which manufacture, use and/or sale are prohibited under any applicable laws and regulations.
- The information contained herein is presented only as a guide for the applications of our products. No responsibility is assumed by TOSHIBA for any infringements of patents or other rights of the third parties which may result from its use. No license is granted by implication or otherwise under any patents or other rights of TOSHIBA or the third parties.
- Please contact your sales representative for product-by-product details in this document regarding RoHS compatibility. Please use these products in this document in compliance with all applicable laws and regulations that regulate the inclusion or use of controlled substances. Toshiba assumes no liability for damage or losses occurring as a result of noncompliance with applicable laws and regulations.