

407-510/521/533

SW Series

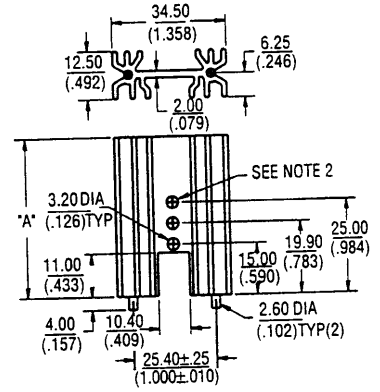

Model	Dim. A mm (inches)	Holes	Cut-out	R _θ (°C/W)	Model	Dim. A mm (inches)	Holes	Cut-out	R _θ (°C/W)
SW25-2	25.00 (.984)	No	No	11.4	SW50-2	50.00 (1.969)	No	No	8.8
SW25-4	25.00 (.984)	Yes	No	11.4	SW50-4	50.00 (1.969)	Yes	No	8.8
SW25-6	25.00 (.984)	Yes	Yes	11.4	SW50-6	50.00 (1.969)	Yes	Yes	8.8
SW38-2	38.00 (1.496)	No	No	10.2	SW63-2	63.00 (2.480)	No	No	7.0
SW38-4	38.00 (1.496)	Yes	No	10.2	SW63-4	63.00 (2.480)	Yes	No	7.0
SW38-6	38.00 (1.496)	Yes	Yes	10.2	SW63-6	63.00 (2.480)	Yes	Yes	7.0

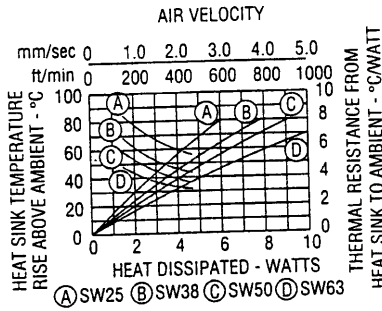

Note 2: This hole is not present in SW25 models.

Recommended PCB Hole Layout:

▲ SW63-6

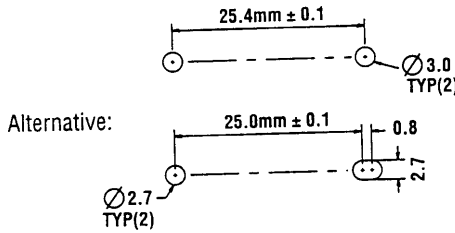

TO-218 etc. this side.
TO-220 etc. opposite side.

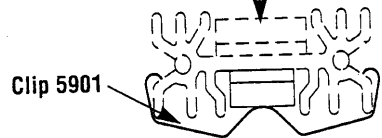

Note: Use spring clip 5901 with -2 variants.

6396 Series



Model	Dim. A mm (inches)	R _θ (°C/W)	Model	Dim. A mm (inches)	R _θ (°C/W)
6396B	25.40 (1.000)	5.6	6399B	50.80 (2.000)	3.3
6398B	38.10 (1.500)	4.4	6400B	63.50 (2.500)	2.7

Note: To order optional solderable roll pin with shoulder, add "-P2" after model number, e.g. 6398B-P2. Shoulder is 1.27 ± .38 / .13 (0.050 ± .015 / .005) thick.

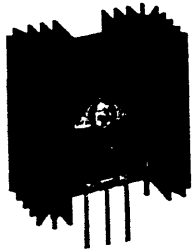

▲ 6396B

