

DSP56001A

Product Preview 24-BIT DIGITAL SIGNAL PROCESSOR

The DSP56001A is an MPU-style general purpose Digital Signal Processor (DSP) composed of an efficient 24-bit DSP core, program and data memories, various peripherals, and support circuitry. The DSP56000 core is fed by on-chip Program RAM, two independent data RAMs, and two data ROMs containing sine, A-law, and μ -law tables. The DSP56001A contains a Serial Communication Interface (SCI), a Synchronous Serial Interface (SSI), and a parallel Host Interface (HI). This combination of features, illustrated in **Figure 1**, makes the DSP56001A a cost-effective, high-performance solution for high-precision general purpose digital signal processing. The DSP56001A is intended as a replacement for the DSP56001. The DSP56002 should be considered for new designs.

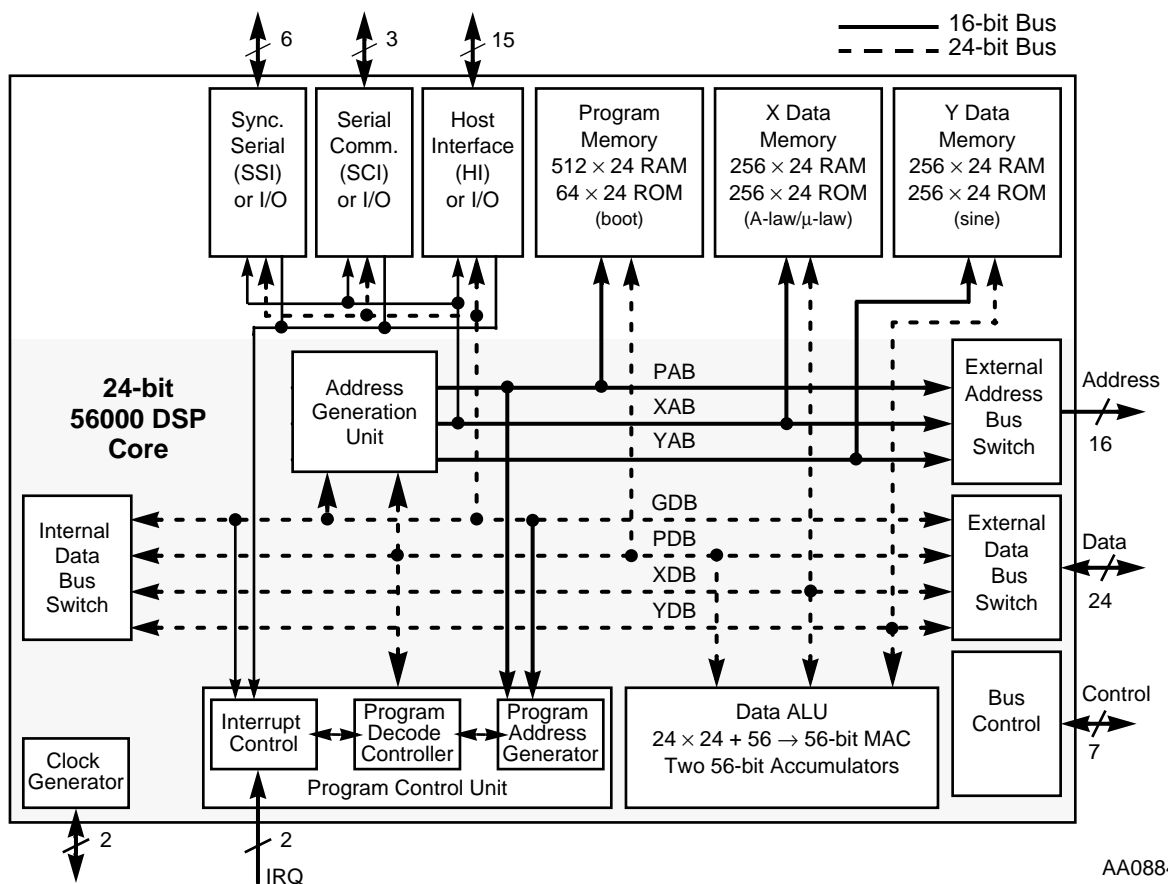

Figure 1 DSP56001A Block Diagram

TABLE OF CONTENTS

SECTION 1 SIGNAL/PIN DESCRIPTIONS 1-1

SECTION 2 SPECIFICATIONS 2-1

SECTION 3 PACKAGING 3-1

SECTION 4 DESIGN CONSIDERATIONS (INCLUDES NOTES FOR DSP56001 TO DSP56001A DESIGN CONVERSION) 4-1

SECTION 5 ORDERING INFORMATION 5-1

SECTION A ROM TABLE LISTINGS A-1

FOR TECHNICAL ASSISTANCE:

Telephone: 1 (800) 521-6274

Email: dsphelp@dsp.sps.mot.com

Internet: <http://www.motorola-dsp.com>

Data Sheet Conventions

This data sheet uses the following conventions:

- OVERBAR Used to indicate a signal that is active when pulled low; for example, the RESET pin is active when low
- “asserted” Means that a high true (active high) signal is high or that a low true (active low) signal is low
- “deasserted” Means that a high true (active high) signal is low or that a low true (active low) signal is high

Examples:	Signal/Symbol	Logic State	Signal State	Voltage
	\overline{PIN}	True	Asserted	V_{IL}/V_{OL}
	\overline{PIN}	False	Deasserted	V_{IH}/V_{OH}
	PIN	True	Asserted	V_{IH}/V_{OH}
	PIN	False	Deasserted	V_{IL}/V_{OL}

Note: Values for V_{IL} , V_{OL} , V_{IH} , and V_{OH} are defined by individual product specifications.

DSP56001A FEATURES

Digital Signal Processing Core

- Efficient, object code compatible, 24-bit 56000 family DSP engine
- Up to 16.5 Million Instructions Per Second (MIPS)—60.6 ns instruction cycle at 33 MHz
- Up to 99 Million Operations Per Second (MOPS) at 33 MHz
- Executes a 1024-point complex Fast Fourier Transform (FFT) in 59,898 clocks
- Highly parallel instruction set with unique DSP addressing modes
- Two 56-bit accumulators including extension byte
- Parallel 24×24 -bit multiply-accumulate in 1 instruction cycle (2 clock cycles)
- Double precision 48×48 -bit multiply with 96-bit result in 6 instruction cycles
- 56-bit addition/subtraction in 1 instruction cycle
- Fractional arithmetic with support for multiprecision arithmetic
- Hardware support for block-floating point FFT
- Hardware nested DO loops
- Zero-overhead fast interrupts (2 instruction cycles)
- Four 24-bit internal data buses and three 16-bit internal address buses for maximum information transfer on-chip

Memory

- On-chip modified Harvard architecture permitting simultaneous accesses to program and two data memories
- 512×24 -bit on-chip Program RAM and 64×24 -bit bootstrap ROM
- Two 256×24 -bit on-chip data RAMs
- Two 256×24 -bit on-chip data ROMs containing sine, A-law and μ -law tables
- External memory expansion with 16-bit address and 24-bit data buses
- Bootstrap loading from external data bus or Host Interface

Peripheral and Support Circuits

- Byte-wide Host Interface (HI) with Direct Memory Access (DMA) support
- Synchronous Serial Interface (SSI) to communicate with codecs and synchronous serial devices
 - 8-, 12-, 16-, and 24-bit word sizes
 - Up to 32 software-selectable time slots in Network mode
- Serial Communication Interface (SCI) for full-duplex asynchronous communications
- On-chip peripheral registers memory mapped in data memory space
- Double-buffered peripherals
- Up to twenty-four General Purpose I/O (GPIO) pins
- Two external interrupt request pins

Miscellaneous Features

- Power-saving Wait and Stop modes
- Fully static, HCMOS design for operating frequencies from 33 MHz down to 4 MHz
- 88-pin Ceramic Pin Grid Array (PGA) package; 13 × 13 array
- 132-pin Plastic Quad Flat Pack (PQFP) surface-mount package; 24 × 24 × 4 mm
- 132-pin Ceramic Quad Flat Pack (CQFP) surface-mount package; 22 × 22 × 4 mm
- 5 V power supply

PRODUCT DOCUMENTATION

The three documents listed in **Table 1** are required for a complete description of the DSP56001A and are necessary to design properly with the part. Documentation is available from one of the following locations (see back cover for detailed information):

- A local Motorola distributor
- A Motorola semiconductor sales office
- A Motorola Literature Distribution Center
- The World Wide Web (WWW)

Table 1 DSP56001A Documentation

Topic	Description	Order Number
DSP56001 User's Manual	Detailed description of the 56001 architecture, 24-bit DSP, memory, peripherals, and instruction set	DSP56001UM/AD
DSP56001A Data Sheet	Pin and package descriptions, and electrical and timing specifications	DSP56001A/D

Related Documentation

Table 2 lists additional documentation relevant to the DSP56001A.

Table 2 DSP56001A Related Documentation

Document Name	Description	Order Number
Digital Sine-Wave Synthesis	Application Report; uses the DSP56001 look-up table	APR1/D
Digital Stereo 10-band Graphic Equalizer	Application Report; includes code and circuitry; features the DSP56001	APR2/D
Fractional and Integer Arithmetic	Application Report; includes code	APR3/D
Implementation of Fast Fourier Transforms	Application Report; comprehensive FFT algorithms and code for DSP56001, DSP56156, and DSP96002	APR4/D
Implementation of PID Controllers	Application Report; PWM using the SCI timer and three phase output using modulo addressing	APR5/D
Convolutional Encoding and Viterbi Decoding with a V.32 Modem Trellis Example	Application Report; theory and code; features the DSP56001	APR6/D
Implementing IIR/FIR Filters	Application Report; comprehensive example using the DSP56001	APR7/D
Principles of Sigma-Delta Modulation for A-to-D Converters	Application Report; features the DSP56ADC16; improving resolution with half-band filters	APR8/D
Full-Duplex 32-kbit/s CCITT ADPCM Speech Coding	Application Report; features the DSP56001	APR9/D
DSP56001 Interface Techniques and Examples	Application Report; interfaces for pseudo Static RAM, Dynamic RAM, ISA bus, Host Interface	APR11/D

Table 2 DSP56001A Related Documentation (Continued)

Document Name	Description	Order Number
Twin CODEC Expansion Board for the DSP56000 ADS	Application Report; circuit, code, FIR filter design for two voice band codecs connecting to the SSI	APR12/D
Conference Bridging in the Digital Telecommunications Environment	Application Report; theory and code; features the DSP56001/002	APR14/D
Implementation of Adaptive Controllers	Application Report; adaptive control using reference models; generalized predictive control; includes code	APR15/D
Calculating Timing Requirements of External SRAM	Application Report; determination of SRAM speed for optimum performance	APR16/D
Low Cost Controller for DSP56001	Application Report; circuit and code to connect two DSP56001s to an MC68008	APR402/D
G.722 Audio Processing	Application Report; theory and code using SB-ADPCM	APR404/D
Minimal Logic DRAM Interface	Application Report; 1M x 480 ns DRAM, 1 PAL, code	APR405/D
Logarithmic/Linear Conversion Routines	Application Report; μ -law and A-law companding routines for PCM mono-circuits	ANE408/D
Third Party Compendium	Brochures from companies selling hardware and software that supports Motorola DSPs	DSP3RDPTYPAK/D
University Support Program	Flyer; Motorola's program supporting Universities in DSP research and education	BR382/D
Technical Training Schedule	Technical Training Schedule	BR348AD/D
Audio Course Information	Audio Course Information	BR928/D
Real Time Signal Processing Applications with Motorola's DSP56000 Family	Textbook by Mohamed El-Sharkawy; 398+ pages. (This is a charge item.)	Prentice-Hall, 1990; ISBN 0-13-767138-5

SECTION 1

SIGNAL/PIN DESCRIPTIONS

INTRODUCTION

DSP56001A signals are organized into twelve functional groups as summarized in **Table 1-1**.

Table 1-1 Signal Functional Group Allocations

Functional Group		Number of Signals	Detailed Description
Power (V _{CCX})		5	Table 1-2
Ground (GND _X)		7	Table 1-3
Clock		2	Table 1-4
Address Bus	Port A ¹	16	Table 1-5
Data Bus		24	Table 1-6
Bus Control		7	Table 1-7
Interrupt and Mode Control		3	Table 1-8
Host Interface (HI) Port	Port B ²	15	Table 1-9
Serial Communications Interface (SCI) Port	Port C ³	3	Table 1-10
Synchronous Serial Interface (SSI) Port		6	Table 1-11
Note: <ol style="list-style-type: none"> 1. Port A signals define the External Memory Interface port. 2. Port B signals are GPIO signals multiplexed on the external pins also used with the HI signals. 3. Port C signals are GPIO signals multiplexed on the external pins also used by the SCI and SSI ports. 			

Figure 1-1 is a diagram of DSP56001A signals by functional group.

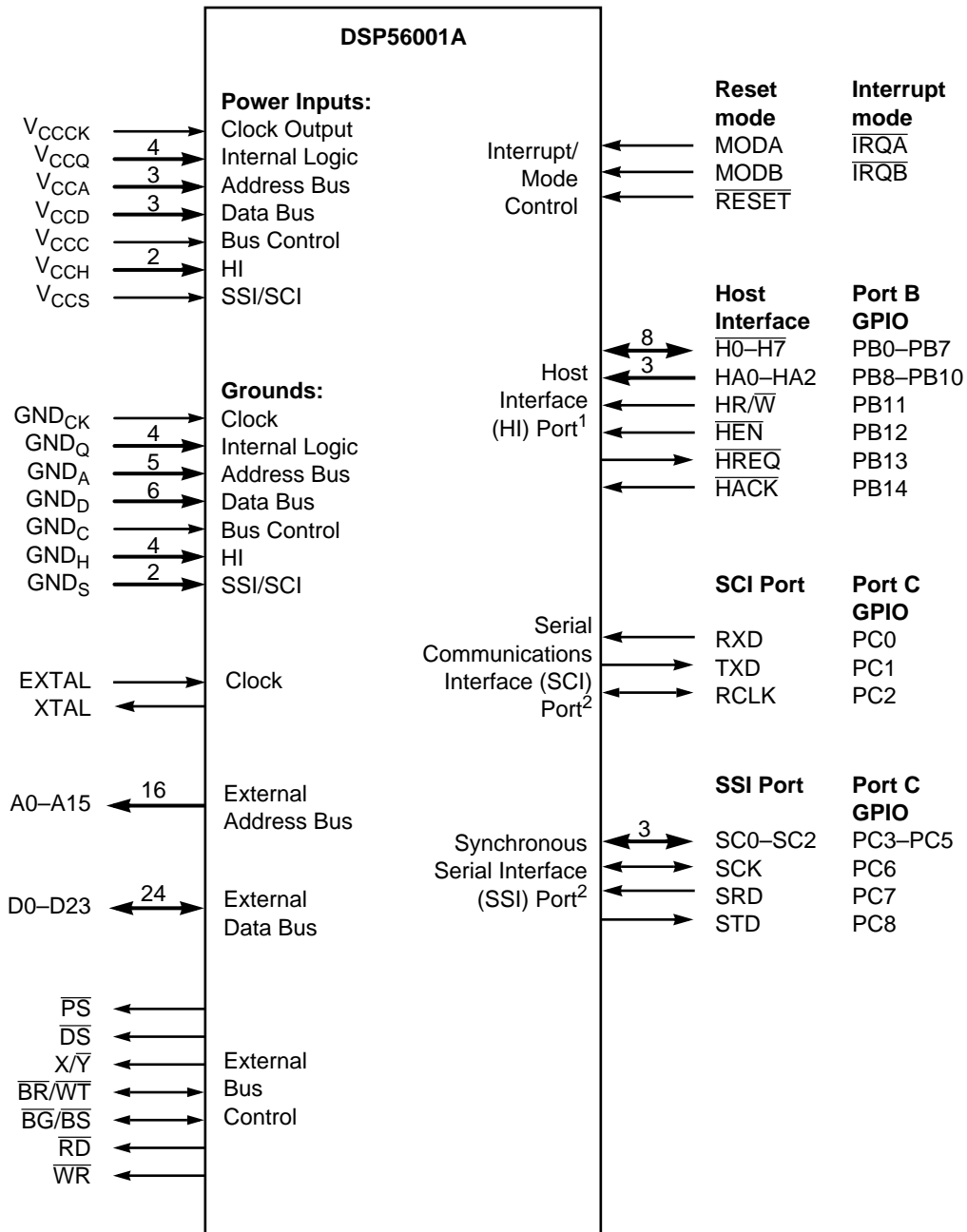

- Note:
1. The Host Interface port signals are multiplexed with the Port B GPIO signals (PB0–PB15).
 2. The SCI and SSI signals are multiplexed with the Port C GPIO signals (PC0–PC8).
 3. Power and ground lines are indicated for the 144-pin TQFP package.

AA0885

Figure 1-1 Signals Identified by Functional Group

POWER

Table 1-2 Power Connections

Power Names	Description
V _{CCQ} (2)	Internal Logic Power —These lines supply a quiet power source to the oscillator circuits and the mode control and interrupt lines. Ensure that the input voltage to this line is well-regulated and uses an extremely low impedance path to tie to the V _{CC} power rail. Use a 0.1 μF bypass capacitor located as close as possible to the chip package to connect between the V _{CCQ} lines and the GND _Q lines.
V _{CCA} (3)	Address Bus Power —These lines supply power to the address bus.
V _{CCD} (3)	Data Bus Power —These lines supply power to the data bus.
V _{CC}	Bus Control Power —This line supplies power to the bus control logic.
V _{CCH} (2)	Host Interface Power —These lines supply power to the Host Interface logic.
V _{CCS}	Serial Interface Power —This line supplies power to the serial interface logic (SCI and SSI).

GROUND

Table 1-3 Ground Connections

Ground Names	Description
GND _Q (2)	Internal Logic Ground —These lines supply a quiet ground connection for the oscillator circuits and the mode control and interrupt lines. Ensure that this line connects through an extremely low impedance path to ground. Use a 0.1 μF bypass capacitor located as close as possible to the chip package to connect between the V _{CCQ} line and the GND _Q line.
GND _A (2)	Address Bus Ground —These lines connect system ground to the address bus.
GND _D (2)	Data Bus Ground —These lines connect system ground to the data bus.
GND _H (1)	Host Interface Ground —These lines supply ground connections for the Host Interface logic.

CLOCK

Table 1-4 Clock Signals

Signal Name	Signal Type	State during Reset	Signal Description
EXTAL	Input	Input	External Clock/Crystal Input —This input should be connected to an external crystal or to an external oscillator.
XTAL	Output	Chip-driven	Crystal Output —This output connects the internal crystal oscillator output to an external crystal. If an external oscillator is used, XTAL should be left unconnected.

ADDRESS BUS

Table 1-5 Address Bus Signals

Signal Names	Signal Type	State during Reset	Signal Description
A0–A15	Output	Tri-stated	Address Bus —These signals specify the address for external program and data memory accesses. If there is no external bus activity, A0–A15 remain at their previous values to reduce power consumption. A0–A15 are tri-stated when the bus grant signal is asserted.

DATA BUS

Table 1-6 Data Bus Signals

Signal Names	Signal Type	State during Reset	Signal Description
D0–D23	Input/Output	Tri-stated	Data Bus —These signals provide the bidirectional data bus for external program and data memory accesses. D0–D23 are tri-stated when the \overline{BG} or \overline{RESET} signal is asserted.

BUS CONTROL

Table 1-7 Bus Control Signals

Signal Name	Signal Type	State during Reset	Signal Description
\overline{PS}	Output	Tri-stated	Program Memory Select — \overline{PS} is asserted low for external program memory access. \overline{PS} is tri-stated when the \overline{BG} or \overline{RESET} signal is asserted.
\overline{DS}	Output	Tri-stated	Data Memory Select — \overline{DS} is asserted low for external data memory access. \overline{DS} is tri-stated when the \overline{BG} or \overline{RESET} signal is asserted.
X/\overline{Y}	Output	Tri-stated	X/\overline{Y} External Memory Select —This output is driven low during external Y data memory accesses. It is also driven low during external exception vector fetches when operating in the Development mode. X/\overline{Y} is tri-stated when the \overline{BG} or \overline{RESET} signal is asserted.
\overline{BR} \overline{WT}	Input/ Output	Tri-stated	Bus Request/Wait —The bus request input \overline{BR} allows another device such as a processor or DMA controller to become master of the external data bus D0–D23 and external address bus a0–a15. When operating mode register (OMR) bit 7 is clear and \overline{BR} is asserted, the DSP56001A will always release the external data bus D0–D23, address bus A0–A15, and bus control signals \overline{PS} , \overline{DS} , X/\overline{Y} , \overline{RD} , and \overline{WR} (i.e. Port A), by tri-stating these pins after execution of the current instruction has been completed. If OMR bit 7 is set, this pin is an input that allows an external device to force wait states during an external Port A operation for as long as \overline{WT} is asserted. Note: To prevent erroneous operation, pull up the $\overline{BR}/\overline{WT}$ signal when it is not in use.
\overline{BG} \overline{BS}	Input/ Output	Tri-stated	Bus Grant/Bus Select —If OMR Bit 7 is clear, this output is asserted to acknowledge an external bus request after Port A has been released. If OMR Bit 7 is set, this signal is bus strobe, and is asserted when the DSP accesses Port A.
\overline{WR}	Output	Tri-stated	Write Enable — \overline{WR} is asserted during external memory write cycles. \overline{WR} is tri-stated when the \overline{BG} or \overline{RESET} signal is asserted.
\overline{RD}	Output	Tri-stated	Read Enable — \overline{RD} is asserted during external memory read cycles. \overline{RD} is tri-stated when the \overline{BG} or \overline{RESET} signal is asserted.

INTERRUPT AND MODE CONTROL

Table 1-8 Interrupt and Mode Control Signals

Signal Name	Signal Type	State during Reset	Signal Description
MODA $\overline{\text{IRQA}}$	Input	Input	<p>Mode Select A/External Interrupt Request A—This input has two functions:</p> <ol style="list-style-type: none"> to select the initial chip operating mode, and after synchronization, to allow an external device to request a DSP interrupt. <p>MODA is read and internally latched in the DSP on exit from Reset. MODA and MODB select the initial chip operating mode. After leaving the Reset state, the MODA signal changes to external interrupt request $\overline{\text{IRQA}}$. The chip operating mode can be changed by software after reset. The $\overline{\text{IRQA}}$ input is a synchronized external interrupt request that indicates that an external device is requesting service. It may be programmed to be level-sensitive or negative-edge-triggered. If level-sensitive triggering is selected, an external pull up resistor is required for wired-OR operation. If the processor is in the Stop state and $\overline{\text{IRQA}}$ is asserted, the processor will exit the Stop state.</p>
MODB $\overline{\text{IRQB}}$	Input	Input	<p>Mode Select B/External Interrupt Request B—This input has two functions:</p> <ol style="list-style-type: none"> to select the initial chip operating mode, and after internal synchronization, to allow an external device to request a DSP interrupt. <p>MODB is read and internally latched in the DSP on exit from Reset. MODA and MODB select the initial chip operating mode. After leaving the Reset state, the MODB signal changes to external interrupt request $\overline{\text{IRQB}}$. After reset, the chip operating mode can be changed by software. The $\overline{\text{IRQB}}$ input is an external interrupt request that indicates that an external device is requesting service. It may be programmed to be level sensitive or negative-edge-triggered. If level-sensitive triggering is selected, an external pull up resistor is required for wired-OR operation.</p>
$\overline{\text{RESET}}$	Input	Input	<p>Reset—This input is a direct hardware reset on the processor. When $\overline{\text{RESET}}$ is asserted low, the DSP is initialized and placed in the Reset state. A Schmitt trigger input is used for noise immunity. When the $\overline{\text{RESET}}$ signal is deasserted, the initial chip operating mode is latched from MODA and MODB. The internal reset signal is deasserted synchronously with the internal clocks.</p>

Freescale Semiconductor, Inc.

CAUTION

**DO NOT APPLY 10 VOLTS TO ANY PIN OF
THE DSP56001A (including MODB)!
Subjecting any pin of the DSP56001A to
voltages in excess of the specified TTL/CMOS
levels will permanently damage the device.**

HOST INTERFACE (HI) PORT

Table 1-9 HI Signals

Signal Name	Signal Type	State during Reset	Signal Description
H0-H7	Input/Output	Tri-stated	Host Data Bus (H0-H7) —This data bus transfers data between the host processor and the DSP56001A. When configured as a Host Interface port, the H0-H7 signals are tri-stated as long as \overline{HEN} is deasserted. The signals are inputs unless HR/\overline{W} is high and \overline{HEN} is asserted, in which case H0-H7 become outputs, allowing the host processor to read the DSP56001A data. H0-H7 become outputs when \overline{HACK} is asserted during \overline{HREQ} assertion.
PB0-PB7	Input or Output		Port B GPIO 0-7 (PB0-PB7) —These signals are GPIO signals (PB0-PB7) when the Host Interface is not selected. After reset, the default state for these signals is GPIO input.
HA0-HA2	Input	Tri-stated	Host Address 0 - Host Address 2 (HA0-HA2) —These inputs provide the address selection for each Host Interface register.
PB8-PB10	Input or Output		Port B GPIO 8-10 (PB8-PB10) —These signals are GPIO signals (PB8-PB10) when the Host Interface is not selected. After reset, the default state for these signals is GPIO input.
HR/\overline{W}	Input	Tri-stated	Host Read/Write —This input selects the direction of data transfer for each host processor access. If HR/\overline{W} is high and \overline{HEN} is asserted, H0-H7 are outputs and DSP data is transferred to the host processor. If HR/\overline{W} is low and \overline{HEN} is asserted, H0-H7 are inputs and host data is transferred to the DSP. HR/\overline{W} must be stable when \overline{HEN} is asserted.
PB11	Input or Output		Port B GPIO 11 (PB11) —This signal is a GPIO signal called PB11 when the Host Interface is not being used. After reset, the default state for this signal is GPIO input.

Freescale Semiconductor, Inc.

Table 1-9 HI Signals (Continued)

Signal Name	Signal Type	State during Reset	Signal Description
$\overline{\text{HEN}}$	Input	Tri-stated	Host Enable —This input enables a data transfer on the host data bus. When $\overline{\text{HEN}}$ is asserted and $\text{HR}/\overline{\text{W}}$ is high, H0–H7 become outputs and the host processor may read DSP56001A data. When $\overline{\text{HEN}}$ is asserted and $\text{HR}/\overline{\text{W}}$ is low, H0–H7 become inputs. Host data is latched in the DSP on the rising edge of $\overline{\text{HEN}}$. Normally, a chip select signal derived from host address decoding and an enable strobe are used to generate $\overline{\text{HEN}}$.
PB12	Input or Output		Port B GPIO 12 (PB12) —This signal is aGPIO signal called PB12 when the Host Interface is not being used. After reset, the default state for this signal is GPIO input.
$\overline{\text{HREQ}}$	Open drain Output	Tri-stated	Host Request —This signal is used by the Host Interface to request service from the host processor, DMA controller, or a simple external controller. Note: $\overline{\text{HREQ}}$ should always be pulled high when it is not in use.
PB13	Input or Output		Port B GPIO 13 (PB13) —This signal is a GPIO (not open-drain) signal (PB13) when the Host Interface is not selected. After reset, the default state for this signal is GPIO input.
$\overline{\text{HACK}}$	Input	Tri-stated	Host Acknowledge —This input has two functions. It provides a host acknowledge handshake signal for DMA transfers and it receives a host interrupt acknowledge compatible with MC68000 family processors. Note: $\overline{\text{HACK}}$ should always be pulled high when it is not in use.
PB14	Input or Output		Port B GPIO 14 (PB14) —This signal is a GPIO signal (PB14) when the Host Interface is not selected, and may be programmed as a GPIO signal when the Host Interface is selected. After reset, the default state for this signal is GPIO input.

SERIAL COMMUNICATIONS INTERFACE PORT

Table 1-10 Serial Communications Interface (SCI) Signals

Signal Name	Signal Type	State during Reset	Signal Description
RXD	Input	Tri-stated	Receive Data (RXD) —This input receives byte-oriented data and transfers the data to the SCI receive shift register. Input data can be sampled on either the positive edge or on the negative edge of the receive clock, depending on how the SCI control register is programmed.
PC0	Input or Output		Port C GPIO 0 (PC0) —This signal is a GPIO signal called PC0 when the SCI RXD function is not being used. After reset, the default state is GPIO input.
TXD	Output	Tri-stated	Transmit Data (TXD) —This output transmits serial data from the SCI transmit shift register. In the default configuration, the data changes on the positive clock edge and is valid on the negative clock edge. The user can reverse this clock polarity by programming the SCI control register appropriately.
PC1	Input or Output		Port C GPIO 1 (PC1) —This signal is a GPIO signal called PC1 when the SCI TXD function is not being used. After reset, the default state is GPIO input.
SCLK	Input/ Output	Tri-stated	SCI Clock (SCLK) —This signal provides an input or output clock from which the transmit/receive baud rate is derived in the Asynchronous mode, and from which data is transferred in the Synchronous mode. The direction and function of the signal is defined by the RCM bit in the SCI Clock Control Register (SCCR).
PC2	Input or Output		Port C GPIO 2 (PC2) —This signal is a GPIO signal called PC2 when the SCI TCLK function is not being used. After reset, the default state is GPIO input.

SYNCHRONOUS SERIAL INTERFACE PORT

Table 1-11 Synchronous Serial Interface (SSI) Signals

Signal Name	Signal Type	State during Reset	Signal Description
SC0 PC3	Input or Output Input or Output	Tri-stated	<p>Serial Clock 0 (SC0)—This signal’s function is determined by whether the SCLK is in Synchronous or Asynchronous mode.</p> <ul style="list-style-type: none"> • In Synchronous mode, this signal is used as a serial I/O flag. • In Asynchronous mode, this signal receives clock I/O. <p>Port C GPIO 3 (PC3)—This signal is GPIO signal PC3 when not configured as SCI signal SC0.</p> <p>After reset, the default state is GPIO input.</p>
SC1 PC4	Input or Output Input or Output	Tri-stated	<p>Serial Clock 1 (SC1)—The SSI uses this bidirectional signal to control flag or frame synchronization. This signal’s function is determined by whether the SCLK is in Synchronous or Asynchronous mode.</p> <ul style="list-style-type: none"> • In Asynchronous mode, this signal is frame sync I/O. • For Synchronous mode with continuous clock, this signal is a serial I/O flag and operates like the SC0. <p>SC0 and SC1 are independent serial I/O flags, but may be used together for multiple serial device selection.</p> <p>Port C GPIO 4 (PC4)—This signal is GPIO signal PC4 when not configured as SSI function SC1.</p> <p>After reset, the default state is GPIO input.</p>
SC2 PC5	Input or Output Input or Output	Tri-stated	<p>Serial Clock 2 (SC2)—The SSI uses this bidirectional signal to control frame synchronization only. As with SC0 and SC1, its function is defined by the SSI operating mode.</p> <p>Port C GPIO 5 (PC5)—This signal is GPIO signal PC5 when not configured as SSI function SC1.</p> <p>After reset, the default state is GPIO input.</p>
SCK PC6	Input or Output Input or Output	Tri-stated	<p>SSI Serial Receive Clock—This bidirectional signal provides the serial bit rate clock for the SSI when only one clock is being used.</p> <p>Port C GPIO 6 (PC6)—This signal is GPIO signal PC6 when the SSI function is not being used.</p> <p>After reset, the default state is GPIO input.</p>

Table 1-11 Synchronous Serial Interface (SSI) Signals (Continued)

Signal Name	Signal Type	State during Reset	Signal Description
SRD	Input	Tri-stated	SSI Receive Data —This input signal receives serial data and transfers the data to the SSI Receive Shift Register.
PC7	Input or Output		<p>Port C GPIO 7 (PC7)—This signal is GPIO signal PC7 when the SSI SRD function is not being used.</p> <p>After reset, the default state is GPIO input.</p>
STD	Output	Tri-stated	SSI Transmit Data (STD) —This output signal transmits serial data from the SSI Transmitter Shift Register.
PC8	Input or Output		<p>Port C GPIO 8 (PC8)—This signal is GPIO signal PC8 when the SSI STD function is not being used.</p> <p>After reset, the default state is GPIO input.</p>



SECTION 2

SPECIFICATIONS

GENERAL CHARACTERISTICS

The DSP56001A is fabricated in high-density HCMOS with TTL compatible inputs and outputs.

Table 2-1 Absolute Maximum Ratings (GND = 0 V)

Rating	Symbol	Value	Unit
Supply Voltage	V_{CC}	-0.3 to +7.0	V
All Input Voltages	V_{IN}	(GND - 0.5) to ($V_{CC} + 0.5$)	V
Current Drain per Pin excluding V_{CC} and GND	I	10	mA
Storage Temperature	T_{stg}	-55 to +150	°C

Note: This device contains circuitry protecting against damage due to high static voltage or electrical fields; however, it is advised that normal precautions be taken to avoid application of any voltages higher than maximum-rated voltages to this high-impedance circuit. Reliability of operation is enhanced if unused inputs are tied to an appropriate logic voltage level (e.g., either GND or V_{CC}).

Table 2-2 Recommended Operating Conditions

Rating	Symbol	Value	Unit
Supply Voltage	V_{CC}	4.5 to 5.5	V
Operating Temperature Range (See Note 1)	T_A	-40 to +105	°C

Table 2-3 Thermal Characteristics for 88-pin PGA Package

Thermal Resistance	Symbol	Value	Rating
Junction to Ambient (See Note 2)	$R_{\theta JA}$	27	°C/W
Junction to Case (estimated) (See Note 3)	$R_{\theta JC}$	6.5	°C/W

General Characteristics

Table 2-4 Thermal Characteristics for 132-pin CQFP/PQFP Packages

Thermal Resistance	Symbol	Value	Rating
Junction to Ambient	$R_{\theta JA}$	40 (CQFP) 47 (PQFP)	°C/W
Junction to Case (estimated)	$R_{\theta JC}$	7.0 (CQFP) 13.0 (PQFP)	°C/W
Note: <ol style="list-style-type: none"> 1. See discussion under Design Considerations, Heat Dissipation, page 4-1. 2. Junction-to-ambient thermal resistance is based on measurements on a horizontal single-sided Printed Circuit Board per SEMI G38-87 in natural convection. SEMI is Semiconductor Equipment and Materials International, 805 East Middlefield Road, Mountain View, CA 94043, (415) 964-5111. 3. Junction-to-case thermal resistance is based on measurements using a cold plate per SEMI G30-88 with the exception that the cold plate temperature is used for the case temperature. 			

DC ELECTRICAL CHARACTERISTICS

Table 2-5 DC Electrical Characteristics

Characteristics	Symbol	Min	Typ	Max	Units
Supply Voltage 27 MHz 33 MHz	V_{CC}	4.5 4.75	5.0 5.0	5.5 5.25	V V
Input High Voltage • EXTAL • $\overline{\text{RESET}}$ • MODA, MODB • All other inputs	V_{IHC} V_{IHR} V_{IHM} V_{IH}	4.0 2.5 3.5 2.0	— — — —	V_{CC} V_{CC} V_{CC} V_{CC}	V V V V
Input Low Voltage • EXTAL • MODA, MODB • All other inputs	V_{ILC} V_{ILM} V_{IL}	-0.5 -0.5 -0.5	— — —	0.6 2.0 0.8	V V V
Input Leakage Current EXTAL, $\overline{\text{RESET}}$, MODA/ $\overline{\text{IRQA}}$, MODB/ $\overline{\text{IRQB}}$, $\overline{\text{DR}}$, $\overline{\text{BR/WT}}$	I_{IN}	-1	—	1	μA
Tri-state (Off-state) Input Current (@ 2.4 V/0.4 V)	I_{TSI}	-10	—	10	μA
Output High Voltage ($I_{OH} = -0.4 \text{ mA}$)	V_{OH}	2.4	—	—	V
Output Low Voltage ($I_{OL} = 1.6 \text{ mA}$) $\overline{\text{HREQ}} I_{OL} = 6.7 \text{ mA}$, TXD $I_{OL} = 6.7 \text{ mA}$	V_{OL}	—	—	0.4	V
Internal Supply Current at 33 MHz (Note 1) • In Wait mode (Note 2) • In Stop mode (Note 2)	I_{CCI} I_{CCW} I_{CCS}	— — —	80 10 2	115 25 2000	mA mA μA
Input Capacitance (Note 3)	C_{IN}	—	10	—	pF
Note:	<ol style="list-style-type: none"> Section 4 Design Considerations describes how to calculate the external supply current. In order to obtain these results all inputs must be terminated (i.e., not allowed to float). Periodically sampled and not 100% tested 				

AC ELECTRICAL CHARACTERISTICS

The timing waveforms in the AC Electrical Characteristics are tested with a V_{IL} maximum of 0.5 V and a V_{IH} minimum of 2.4 V for all pins, except EXTAL, $\overline{\text{RESET}}$, MODA, and MODB. These pins are tested using the input levels set forth in the DC electrical characteristics. AC timing specifications that are referenced to a device input signal are measured in production with respect to the 50% point of the respective input signal's transition. DSP56001A output levels are measured with the production test machine V_{OL} and V_{OH} reference levels set at 0.8 V and 2.0 V, respectively.

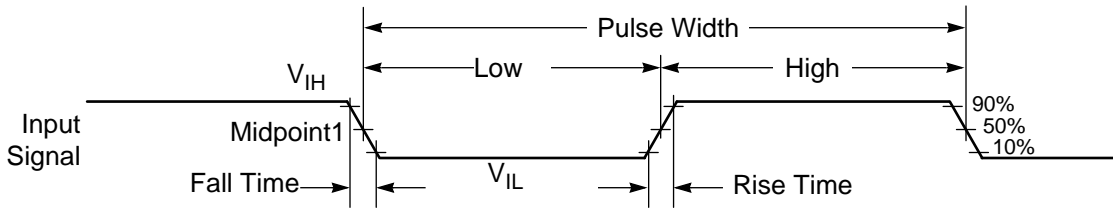

Note: The midpoint is $V_{IL} + (V_{IH} - V_{IL})/2$.

AA0179

Figure 2-1 Signal Measurement Reference

INTERNAL CLOCKS

For each occurrence of T_H , T_L , T_C or I_{CYC} , substitute with the numbers in Table 2-6.

Table 2-6 Internal Clocks

Characteristics	Symbol	Expression
Internal Operation Frequency	f	
Internal Clock High Period	T_H	ET_H
Internal Clock Low Period	T_L	ET_L
Internal Clock Cycle Time	T_C	ET_C
Instruction Cycle Time	I_{CYC}	$2 \times T_C$

EXTERNAL CLOCK (EXTAL PIN)

The DSP56001A system clock may be derived from the on-chip crystal oscillator as shown in **Figure 2-2**, or it may be externally supplied. An externally supplied square wave voltage source should be connected to EXTAL, leaving XTAL physically unconnected to the board or socket. The rise and fall times of this external clock should be 4 ns maximum.

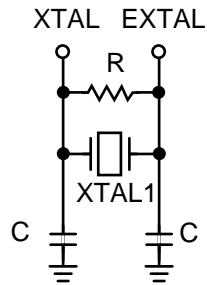

**Fundamental Frequency
Crystal Oscillator**

Suggested Component
Values

R = 680 kΩ ± 10%
C = 20 pf ± 20%

- Note:
1. The suggested crystal source is ICM, # 433163 – 4.00 (4 MHz fundamental, 20 pf load) or # 436163 – 30.00 (30 MHz fundamental, 20 pf load)
 2. To reduce system cost, a ceramic resonator may be used instead of the crystal. Suggested source: Murata-Erie #CST4.00MGW040 (4 MHz with built-in load capacitors)

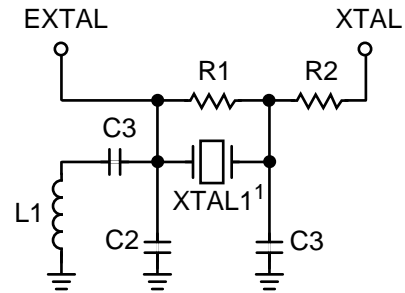

**3rd Overtone
Crystal Oscillator**

Suggested Component Values

R1 = 470 kΩ ± 10%
R2 = 330 Ω ± 10%
C1 = 0.1 μf ± 20%
C2 = 26 pf ± 20%
C3 = 20 pf ± 10%
L1 = 2.37 μH ± 10%
XTAL = 33 MHz, AT cut, 20 pf load,
50 Ω max series resistance

- Note:
1. 3rd overtone crystal
 2. The suggested crystal source is ICM, # 471163 – 33.00 (33 MHz 3rd overtone, 20 pf load)
 3. R2 limits crystal current
 4. Reference Benjamin Parzen, The Design of Crystal and Other Harmonic Oscillators, John Wiley & Sons, 1983

AA0886

Figure 2-2 Crystal Oscillator Circuits

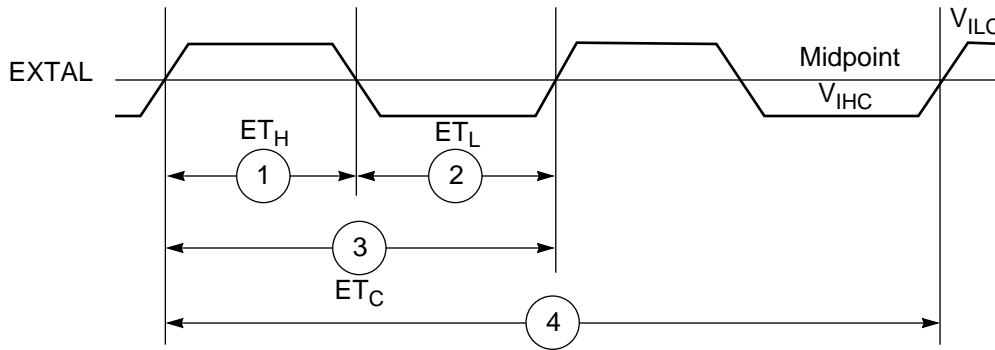

NOTE: The midpoint is $V_{ILC} + 0.5(V_{IHC} - V_{ILC})$.

AA0360

Figure 2-3 External Clock Timing

Table 2-7 Clock Operation

No	Characteristics	Symbol	27 MHz		33 MHz		Unit
			Min	Max	Min	Max	
	Frequency of Operation (EXTAL Pin)	E_f	4	27	4	33	MHz
1	Clock Input High (46.7% - 53.3% duty cycle)	ET_H	17	150	13.5	150	ns
2	Clock Input Low (46.7% - 53.3% duty cycle)	ET_L	17	150	13.5	150	ns
3	Clock Cycle Time	ET_C	37	250	30	250	ns
4	Instruction Cycle Time = $I_{CYC} = 2 \times T_C$	I_{CYC}	74	500	60	500	ns
Note: External Clock Input High and External Clock Input Low are reserved at 50% of the input transition.							

RESET, STOP, MODE SELECT, AND INTERRUPT TIMING

$V_{CC} = 5.0\text{ V} \pm 10\%$ for 27 MHz; $V_{CC} = 5.0\text{ V} \pm 5\%$ for 33 MHz

$T_J = -40$ to $+105\text{ }^\circ\text{C}$; $C_L = 50\text{ pF} + 1\text{ TTL loads}$

WS = number of wait states programmed into the external bus access using BCR (WS = 0–15)

Table 2-8 Reset, Stop, Mode Select, and Interrupt Timing (27/33 MHz)

Num	Characteristics	27 MHz		33 MHz		Unit
		Min	Max	Min	Max	
9	Delay from $\overline{\text{RESET}}$ Assertion to Address High Impedance (periodically sampled and not 100% tested)	—	38	—	31	ns
10	Minimum Stabilization Duration <ul style="list-style-type: none"> Internal Oscillator (See Note 1) External clock (See Note 2) 	$75000 \times T_C$ $25 \times T_C$	— —	$75000 \times T_C$ $25 \times T_C$	— —	ns ns
11	Delay from Asynchronous $\overline{\text{RESET}}$ Deassertion to First External Address Output (Internal Reset Deassertion)	$8 \times T_C$	$9 \times T_C + 31$	$8 \times T_C$	$9 \times T_C + 25$	ns
12	Synchronous Reset Setup Time from $\overline{\text{RESET}}$ Deassertion to first CKOUT transition	15	$T_C - 8$	13	$T_C - 7$	ns
13	Synchronous Reset Delay Time from the first CKOUT transition to the First External Address Output	$8 \times T_C + 5$	$8 \times T_C + 23$	$8 \times T_C + 5$	$8 \times T_C + 19$	ns
14	Mode Select Setup Time	77	—	62	—	ns
15	Mode Select Hold Time	0	—	0	—	ns
16	Minimum Edge-Triggered Interrupt Request Assertion Width	17	—	16	—	ns
16a	Minimum Edge-Triggered Interrupt Request Deassertion Width	10	—	10	—	ns

Table 2-8 Reset, Stop, Mode Select, and Interrupt Timing (27/33 MHz) (Continued)

Num	Characteristics	27 MHz		33 MHz		Unit
		Min	Max	Min	Max	
17	Delay from \overline{IRQA} , \overline{IRQB} Assertion to External Memory Access Address Out Valid <ul style="list-style-type: none"> • Caused by First Interrupt Instruction Fetch • Caused by First Interrupt Instruction Execution 	$5 \times T_C + T_H$	—	$5 \times T_C + T_H$	—	ns
		$9 \times T_C + T_H$	—	$9 \times T_C + T_H$	—	ns
18	Delay from \overline{IRQA} , \overline{IRQB} Assertion to General Purpose Transfer Output Valid caused by First Interrupt Instruction Execution	$11 \times T_C + T_H$	—	$11 \times T_C + T_H$	—	ns
19	Delay from Address Output Valid caused by First Interrupt Instruction Execute to Interrupt Request Deassertion for Level-Sensitive Fast Interrupts (See Note 3)	—	$2 \times T_C + T_L + (T_C \times WS) - 34$	—	$2 \times T_C + T_L + (T_C \times WS) - 27$	ns
20	Delay from \overline{RD} Assertion to Interrupt Request Deassertion for Level-Sensitive Fast Interrupts (See Note 3)	—	$2 \times T_C + (T_C \times WS) - 31$	—	$2 \times T_C + (T_C \times WS) - 25$	ns
21	Delay from \overline{WR} Assertion to Interrupt Request Deassertion for Level-Sensitive Fast Interrupts (See Note 3) <ul style="list-style-type: none"> • $WS = 0$ • $WS > 0$ 	—	$2 \times T_C - 31$	—	$2 \times T_C - 25$	ns
		—	$T_C + T_L + (T_C \times WS) - 31$	—	$T_C + T_L + (T_C \times WS) - 25$	ns

Table 2-8 Reset, Stop, Mode Select, and Interrupt Timing (27/33 MHz) (Continued)

Num	Characteristics	27 MHz		33 MHz		Unit
		Min	Max	Min	Max	
22	Delay from General-Purpose Output Valid to Interrupt Request Deassertion for Level-Sensitive Fast Interrupts (See Note 3)—If Second Interrupt Instruction is: <ul style="list-style-type: none"> • Single Cycle • Two Cycles 	—	$T_L - 46$	—	$T_L - 37$	ns
		—	$2 \times T_C + T_L - 46$	—	$2 \times T_C + T_L - 37$	ns
23	Synchronous Interrupt Setup Time from \overline{IRQA} , \overline{IRQB} Assertion to the second CKOUT transition	19	$T_C - 8$	16	$T_C - 6$	ns
24	Synchronous Interrupt Delay Time from the second CKOUT transition to the First External Address Output Valid caused by the First Instruction Fetch after coming out of Wait State	$13 \times T_C + T_H + 6$	$13 \times T_C + T_H + 23$	$13 \times T_C + T_H + 5$	$13 \times T_C + T_H + 19$	ns
25	Duration for \overline{IRQA} Assertion to Recover from Stop State	19	—	16	—	ns
26	Delay from \overline{IRQA} Assertion to Fetch of First Interrupt Instruction (when exiting 'Stop') (See Note 1) <ul style="list-style-type: none"> • Internal Crystal Oscillator Clock, OMR Bit 6 = 0 • Stable External Clock, OMR Bit 6 = 1 	$65548 \times T_C$	—	$65548 \times T_C$	—	ns
		$20 \times T_C$	—	$20 \times T_C$	—	ns
27	Duration of Level-Sensitive \overline{IRQA} Assertion to ensure interrupt service (when exiting 'Stop') (See Note 1) <ul style="list-style-type: none"> • Internal Crystal Oscillator Clock, OMR Bit 6 = 0 • Stable External Clock, OMR Bit 6 = 1 	$65534 \times T_C + T_L$	—	$65534 \times T_C + T_L$	—	ns
		$6 \times T_C + T_L$	—	$6 \times T_C + T_L$	—	ns

Table 2-8 Reset, Stop, Mode Select, and Interrupt Timing (27/33 MHz) (Continued)

Num	Characteristics	27 MHz		33 MHz		Unit
		Min	Max	Min	Max	
28	Delay from Level-Sensitive $\overline{\text{IRQA}}$ Assertion to Fetch of First Interrupt Instruction (when exiting 'Stop') (See Note 1) <ul style="list-style-type: none"> • Internal Crystal Oscillator Clock, OMR Bit 6 = 0 • Stable External Clock, OMR Bit 6 = 1 	65548 × T _C	—	65548 × T _C	—	ns
		20 × T _C	—	20 × T _C	—	ns
Note: <ol style="list-style-type: none"> 1. A clock stabilization delay is required when using the on-chip crystal oscillator in two cases: <ul style="list-style-type: none"> • after power-on reset, and • when recovering from Stop mode. During this stabilization period, T_C, T_H, and T_L will not be constant. Since this stabilization period varies, a delay of 75,000 × T_C is typically allowed to assure that the oscillator is stable before executing programs. While it is possible to set OMR Bit 6 = 1 when using the internal crystal oscillator, it is not recommended and these specifications do not guarantee timings for that case. 2. Circuit stabilization delay is required during reset when using an external clock in two cases: <ul style="list-style-type: none"> • after power-on reset, and • when recovering from Stop mode. 3. When using fast interrupts and $\overline{\text{IRQA}}$ and $\overline{\text{IRQB}}$ are defined as level-sensitive, then timings 19 through 22 apply to prevent multiple interrupt service. To avoid these timing restrictions, the deasserted Edge-Triggered mode is recommended when using fast interrupt. Long interrupts are recommended when using Level-Sensitive mode. 						

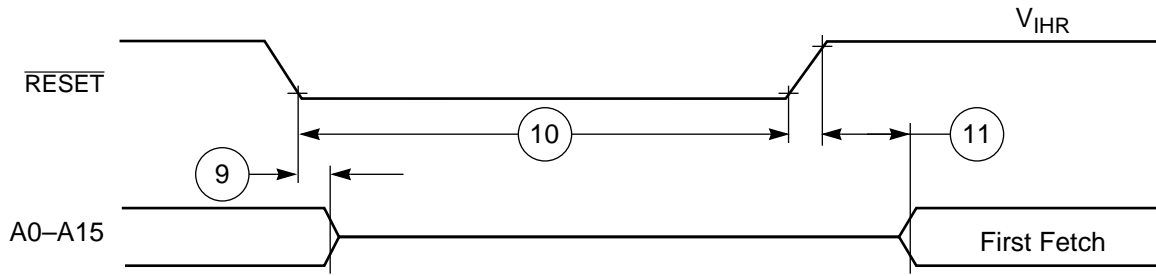

AA0356

Figure 2-4 Reset Timing

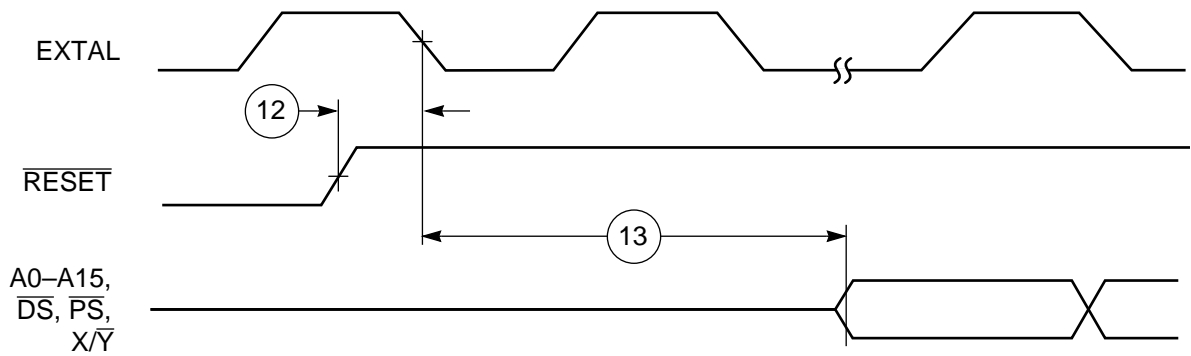

AA0887

Figure 2-5 Synchronous Reset Timing

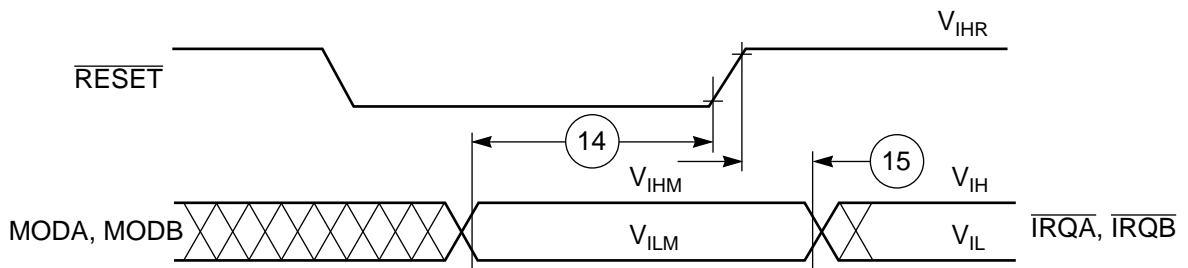

AA0888

Figure 2-6 Operating Mode Select Timing

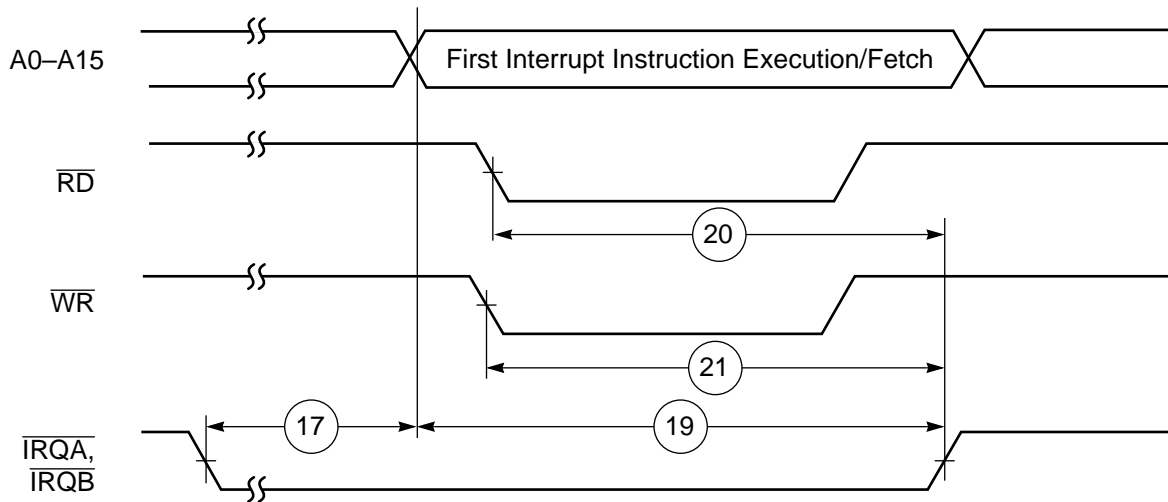

a) First Interrupt Instruction Execution

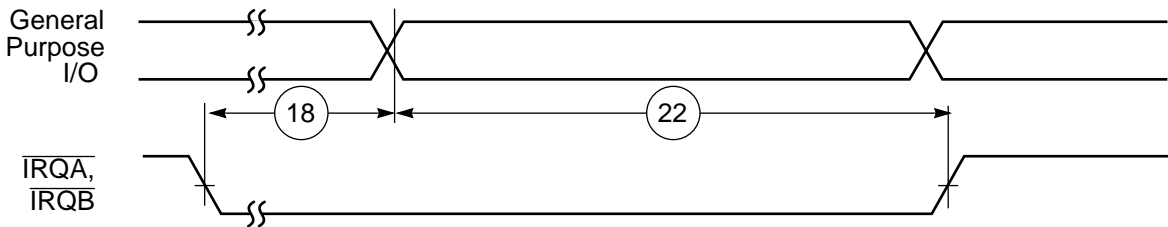

b) General Purpose I/O

AA0889

Figure 2-7 External Level-Sensitive Fast Interrupt Timing

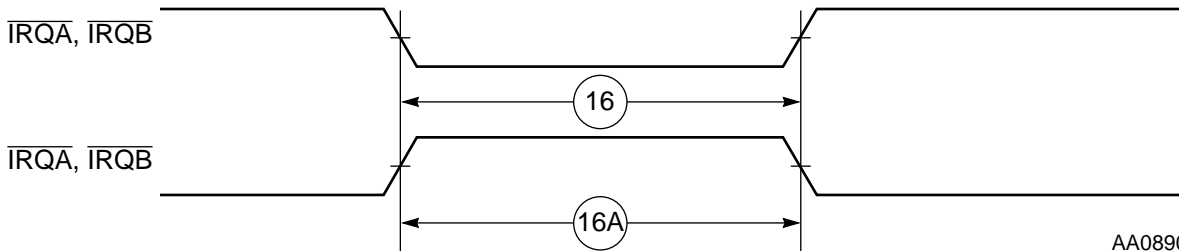

AA0890

Figure 2-8 External Interrupt Timing (Negative Edge-Triggered)

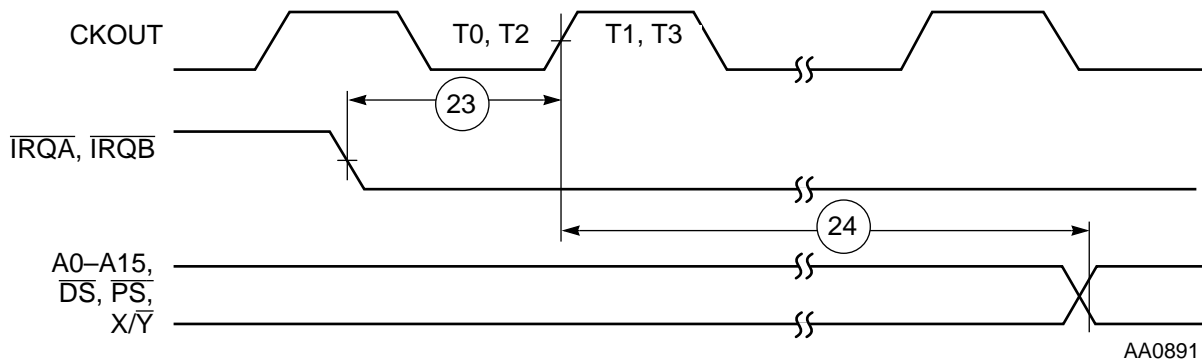

Figure 2-9 Synchronous Interrupt from Wait State Timing

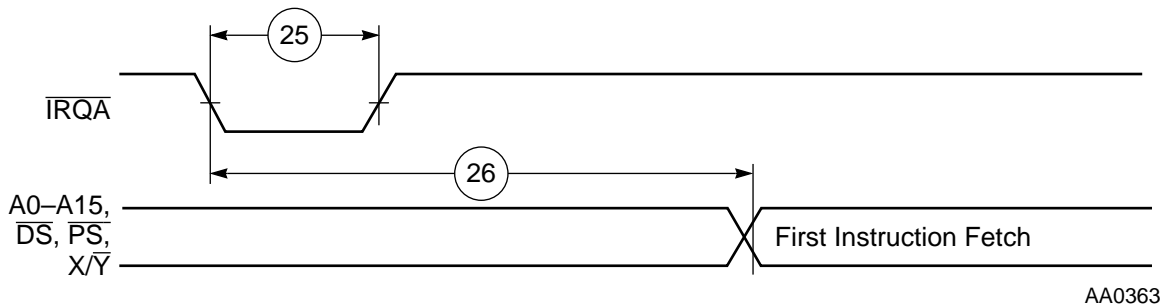

Figure 2-10 Recovery from Stop State Using IRQA

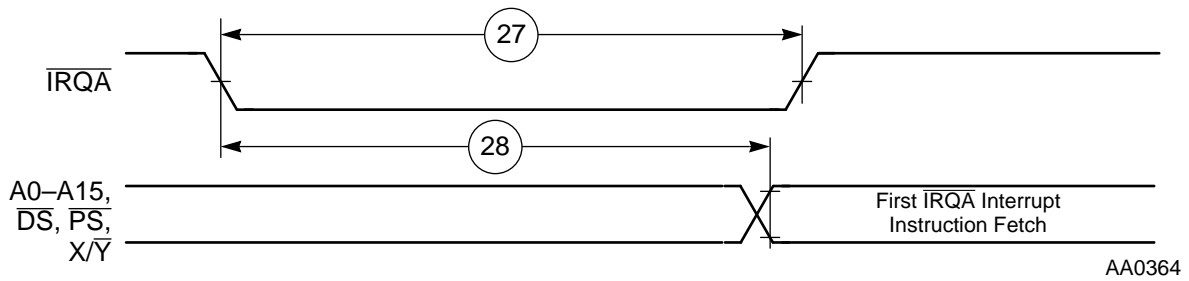

Figure 2-11 Recovery from Stop State Using IRQA Interrupt Service

HOST I/O (HI) TIMING

$V_{CC} = 5.0\text{ V} \pm 10\%$ for 27 MHz; $5.0\text{ V} \pm 5\%$ for 33 MHz;
 $T_J = -40\text{ to }105\text{ }^\circ\text{C}$; $C_L = 50\text{ pF} + 1\text{ TTL loads}$

Note: Active low lines should be pulled up in a manner consistent with the AC and DC specifications.

Table 2-9 Host I/O Timing (27/33 MHz)

Num	Characteristics	27 MHz		33 MHz		Unit
		Min	Max	Min	Max	
30	Host Synchronization Delay (see Note 1)	T_L	$T_C + T_L$	T_L	$T_C + T_L$	ns
31	$\overline{\text{H}}\overline{\text{E}}\overline{\text{N}}/\overline{\text{H}}\overline{\text{A}}\overline{\text{C}}\overline{\text{K}}$ Assertion Width (See Note 2) <ul style="list-style-type: none"> CVR, ICR, ISR, RXL Read IVR, RXH/M Read Write 	$T_C + 46$	—	$T_C + 37$	—	ns
		39	—	31	—	ns
		19	—	16	—	ns
32	$\overline{\text{H}}\overline{\text{E}}\overline{\text{N}}/\overline{\text{H}}\overline{\text{A}}\overline{\text{C}}\overline{\text{K}}$ Deassertion Width (See Note 2) <ul style="list-style-type: none"> Between Two TXL Writes (See Note 3) Between Two CVR, ICR, ISR, RXL Reads (See Note 4) 	19	—	16	—	ns
		$2 \times T_C + 46$	—	$2 \times T_C + 37$	—	ns
		$2 \times T_C + 46$	—	$2 \times T_C + 37$	—	ns
33	Host Data Input Setup Time Before $\overline{\text{H}}\overline{\text{E}}\overline{\text{N}}/\overline{\text{H}}\overline{\text{A}}\overline{\text{C}}\overline{\text{K}}$ Deassertion	4	—	4	—	ns
34	Host Data Input Hold Time After $\overline{\text{H}}\overline{\text{E}}\overline{\text{N}}/\overline{\text{H}}\overline{\text{A}}\overline{\text{C}}\overline{\text{K}}$ Deassertion	4	—	4	—	ns
35	$\overline{\text{H}}\overline{\text{E}}\overline{\text{N}}/\overline{\text{H}}\overline{\text{A}}\overline{\text{C}}\overline{\text{K}}$ Assertion to Output Data Active from High Impedance	0	—	0	—	ns
36	$\overline{\text{H}}\overline{\text{E}}\overline{\text{N}}/\overline{\text{H}}\overline{\text{A}}\overline{\text{C}}\overline{\text{K}}$ Assertion to Output Data Valid	—	39	—	31	ns
37	$\overline{\text{H}}\overline{\text{E}}\overline{\text{N}}/\overline{\text{H}}\overline{\text{A}}\overline{\text{C}}\overline{\text{K}}$ Deassertion to Output Data High Impedance (See Note 6)	—	27	—	22	ns
38	Output Data Hold Time After $\overline{\text{H}}\overline{\text{E}}\overline{\text{N}}/\overline{\text{H}}\overline{\text{A}}\overline{\text{C}}\overline{\text{K}}$ Deassertion (See Note 7)	4	—	4	—	ns

Table 2-9 Host I/O Timing (Continued)(27/33 MHz) (Continued)

Num	Characteristics	27 MHz		33 MHz		Unit
		Min	Max	Min	Max	
39	HR/ \overline{W} Low Setup Time Before \overline{HEN} Assertion	0	—	0	—	ns
40	HR/ \overline{W} Low Hold Time After \overline{HEN} Deassertion	4	—	4	—	ns
41	HR/ \overline{W} High Setup Time to \overline{HEN} Assertion	0	—	0	—	ns
42	HR/ \overline{W} High Hold Time After $\overline{HEN}/\overline{HACK}$ Deassertion	4	—	4	—	ns
43	HA0-HA2 Setup Time Before \overline{HEN} Assertion	0	—	0	—	ns
44	HA0-HA2 Hold Time After \overline{HEN} Deassertion	4	—	4	—	ns
45	DMA \overline{HACK} Assertion to \overline{HREQ} Deassertion (See Note 5)	4	46	4	46	ns
46	DMA \overline{HACK} Deassertion to \overline{HREQ} Assertion (See Notes 5, 6)					
	• for DMA RXL Read	$t_{HSDL} + T_C + T_H + 4$	—	$t_{HSDL} + T_C + T_H + 4$	—	ns
	• for DMA TXL Write	$t_{HSDL} + T_C + 4$	—	$t_{HSDL} + T_C + 4$	—	ns
	• all other cases	4	—	4	—	ns
47	Delay from \overline{HEN} Deassertion to \overline{HREQ} Assertion for RXL Read (See Notes 5, 6)	$t_{HSDL} + T_C + T_H + 4$	—	$t_{HSDL} + T_C + T_H + 4$	—	ns
48	Delay from \overline{HEN} Deassertion to \overline{HREQ} Assertion for TXL Write (See Notes 5, 6)	$t_{HSDL} + T_C + 4$	—	$t_{HSDL} + T_C + 4$	—	ns
49	Delay from \overline{HEN} Assertion to \overline{HREQ} Deassertion for RXL Read, TXL Write (See Notes 5, 6)	4	70	4	65	ns
Note:	<ol style="list-style-type: none"> Host synchronization delay (t_{HSDL}) is the time period required for the DSP56001 to sample any external asynchronous input signal, determine whether it is high or low, and synchronize it to the DSP56001 internal clock. See Host Port Considerations in the section on Design Considerations. This timing must be adhered to only if two consecutive writes to the TXL are executed without polling TXDE or \overline{HREQ}. This timing must be adhered to only if two consecutive reads from one of these registers are executed without polling the corresponding status bits or \overline{HREQ}. \overline{HREQ} is pulled up by a 1 kΩ resistor. Specifications are periodically sampled and not 100% tested. May decrease to 0 ns for future versions. 					

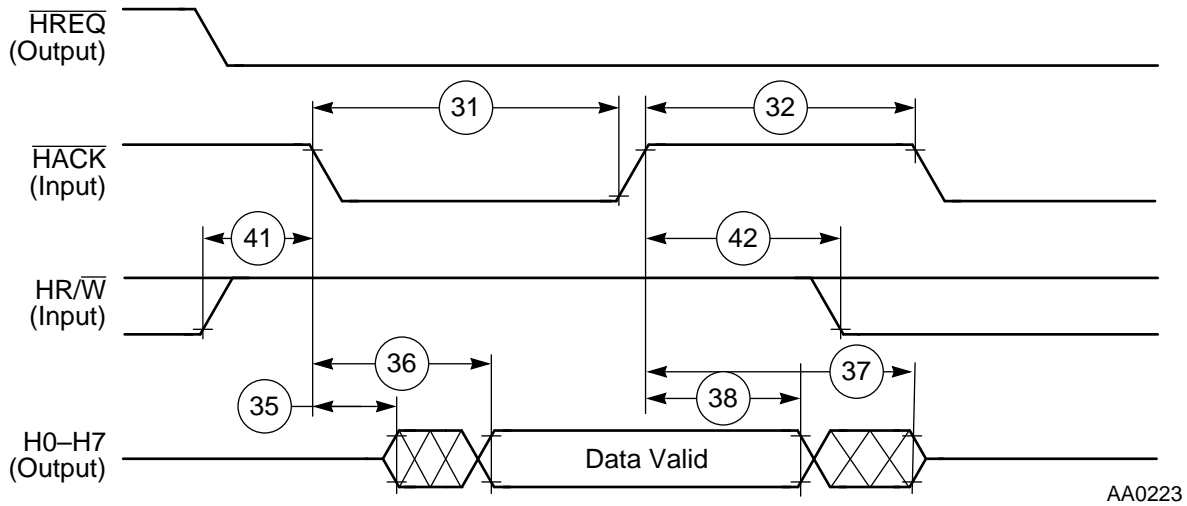

Figure 2-12 Host Interrupt Vector Register (IVR) Read

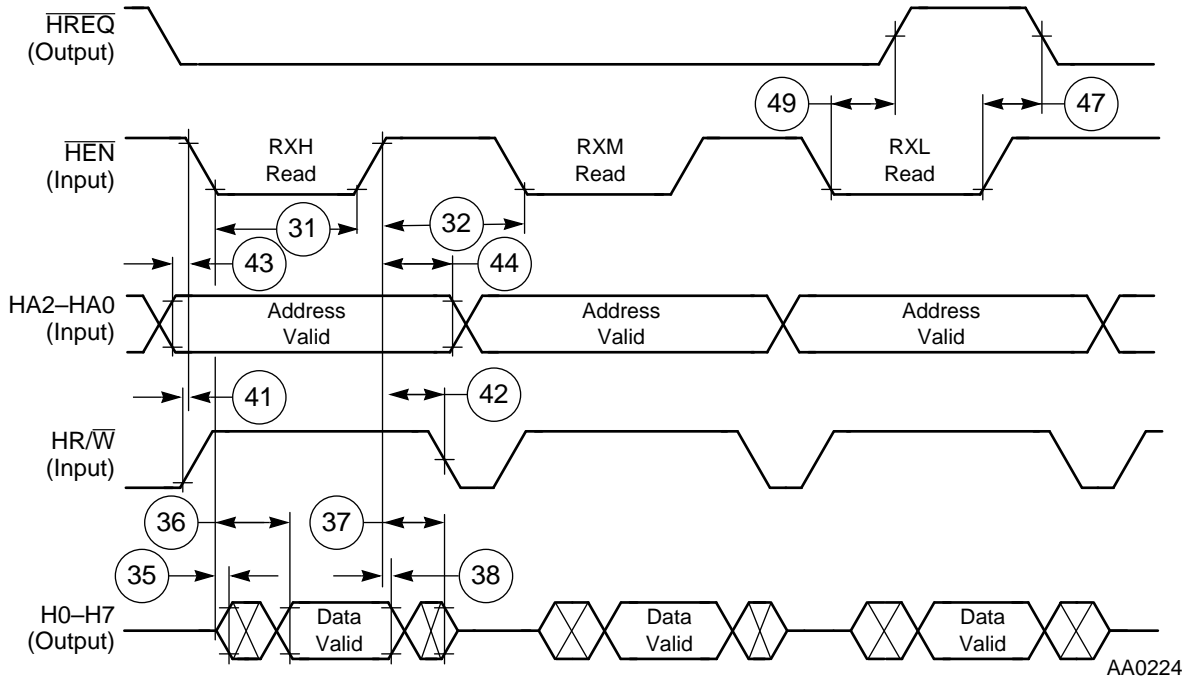
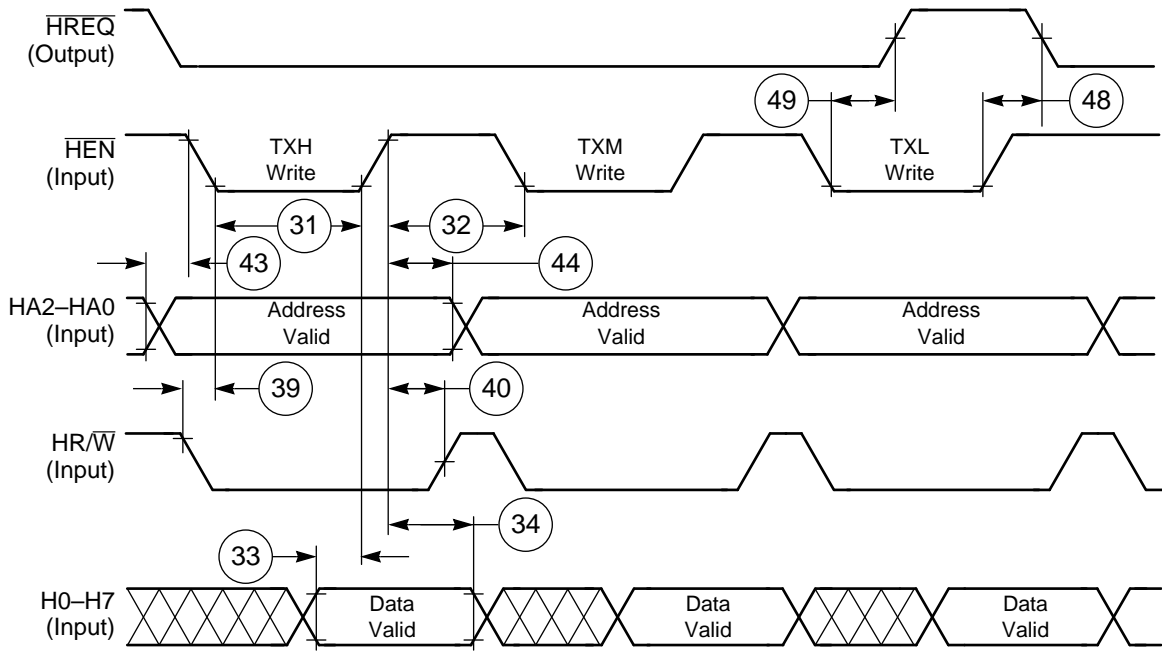
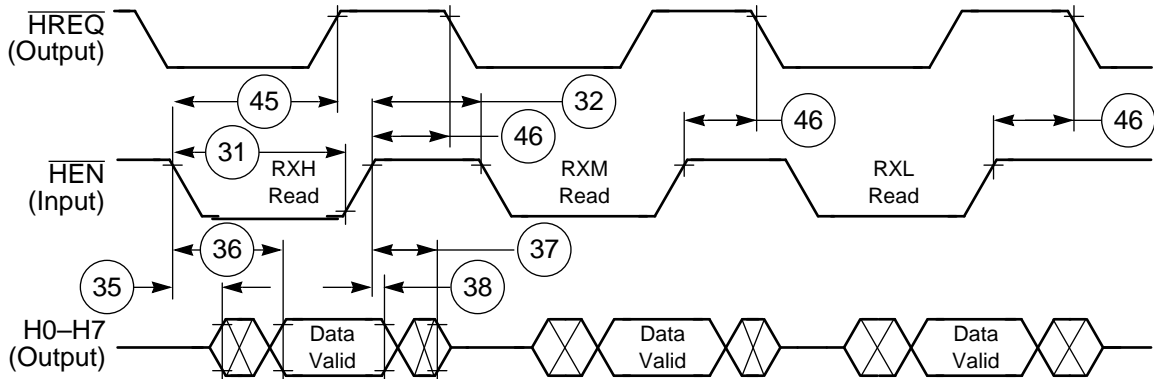

Figure 2-13 Host Read Cycle (Non-DMA Mode)



AA0225

Figure 2-14 Host Write Cycle (Non-DMA Mode)



AA0230

Figure 2-15 Host DMA Read Cycle

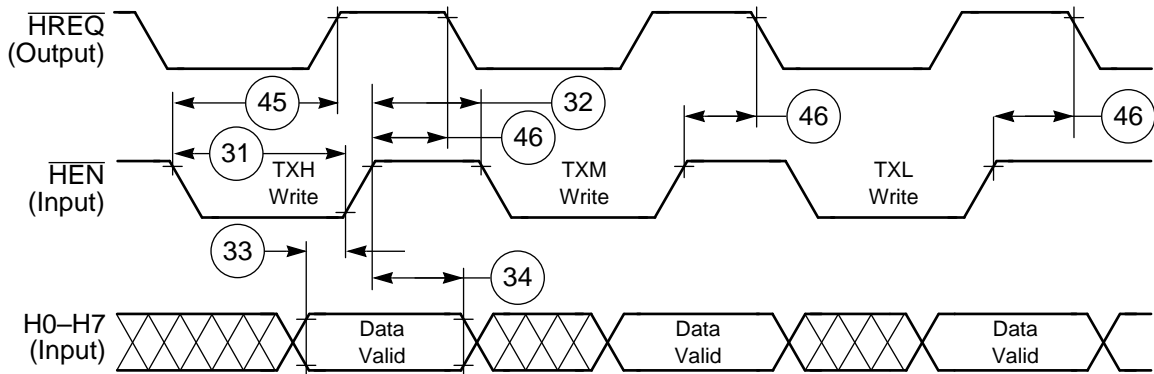

AA0231

Figure 2-16 Host DMA Write Cycle

SERIAL COMMUNICATION INTERFACE (SCI) TIMING

$V_{CC} = 5.0\text{ V} \pm 10\%$ for 27 MHz; $5.0\text{ V} \pm 5\%$ for 33 MHz;

$T_J = -40$ to $105\text{ }^\circ\text{C}$; $C_L = 50\text{ pF} + 1\text{ TTL loads}$

t_{SCC} = Synchronous Clock Cycle Time (For internal clock, t_{SCC} is determined by the SCI Clock Control Register and T_C .) The minimum t_{SCC} value is $8 \times T_C$.

Table 2-10 SCI Synchronous Mode Timing (27/33 MHz)

Num	Characteristics	27 MHz		33 MHz		Unit
		Min	Max	Min	Max	
55	Synchronous Clock Cycle— t_{SCC}	$8 \times T_C$	—	$8 \times T_C$	—	ns
56	Clock Low Period	$4 \times T_C - 15$	—	$4 \times T_C - 13$	—	ns
57	Clock High Period	$4 \times T_C - 15$	—	$4 \times T_C - 13$	—	ns
58	< intentionally blank >	—	—	—	—	—
59	Output Data Setup to Clock Falling Edge (Internal Clock)	$2 \times T_C + T_L - 39$	—	$2 \times T_C + T_L - 31$	—	ns
60	Output Data Hold After Clock Rising Edge (Internal Clock)	$2 \times T_C - T_L - 11$	—	$2 \times T_C - T_L - 9$	—	ns
61	Input Data Setup Time Before Clock Rising Edge (Internal Clock)	$2 \times T_C + T_L + 35$	—	$2 \times T_C + T_L + 28$	—	ns
62	Input Data Not Valid Before Clock Rising Edge (Internal Clock)	—	$2 \times T_C + T_L - 8$	—	$2 \times T_C + T_L - 6$	ns
63	Clock Falling Edge to Output Data Valid (External Clock)	—	48	—	39	ns
64	Output Data Hold After Clock Rising Edge (External Clock)	$T_C + 9$	—	$T_C + 8$	—	ns
65	Input Data Setup Time Before Clock Rising Edge (External Clock)	23	—	19	—	ns
66	Input Data Hold Time After Clock Rising Edge (External Clock)	31	—	25	—	ns

Freescale Semiconductor, Inc.

Table 2-11 SCI Asynchronous Mode Timing — 1X Clock

Num	Characteristics	27 MHz		33 MHz		Unit
		Min	Max	Min	Max	
67	Asynchronous Clock Cycle— t_{ACC}	$64 \times T_C$	—	$64 \times T_C$	—	ns
68	Clock Low Period	$32 \times T_C - 15$	—	$32 \times T_C - 13$	—	ns
69	Clock High Period	$32 \times T_C - 15$	—	$32 \times T_C - 13$	—	ns
70	< intentionally blank >	—	—	—	—	—
71	Output Data Setup to Clock Rising Edge (Internal Clock)	$32 \times T_C - 77$	—	$32 \times T_C - 61$	—	ns
72	Output Data Hold After Clock Rising Edge (Internal Clock)	$32 \times T_C - 77$	—	$32 \times T_C - 61$	—	ns

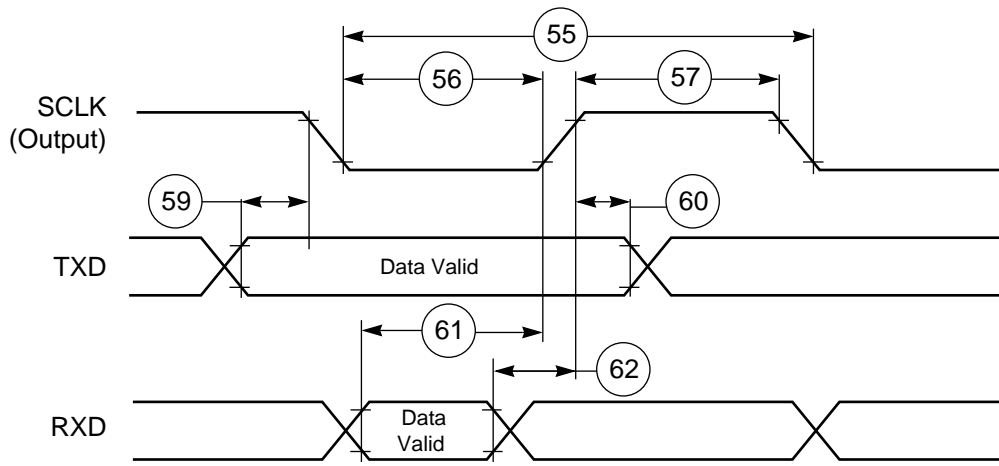

a) Internal Clock

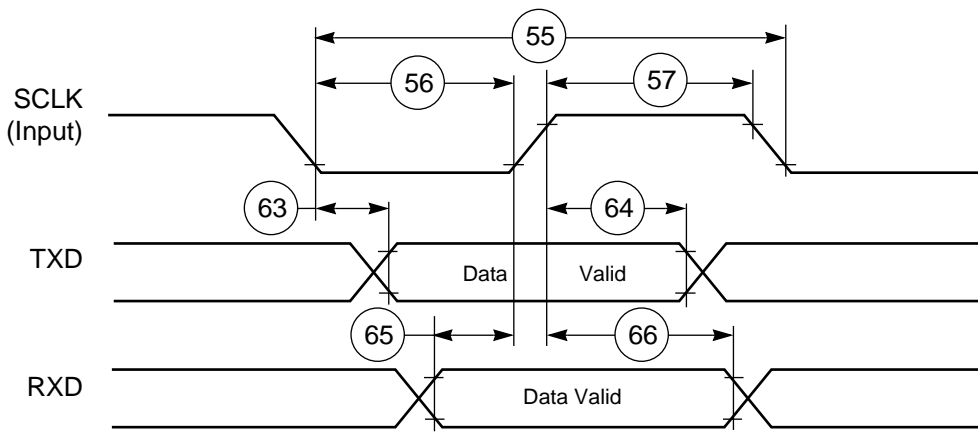

b) External Clock

AA0892

Figure 2-17 SCI Synchronous Mode Timing

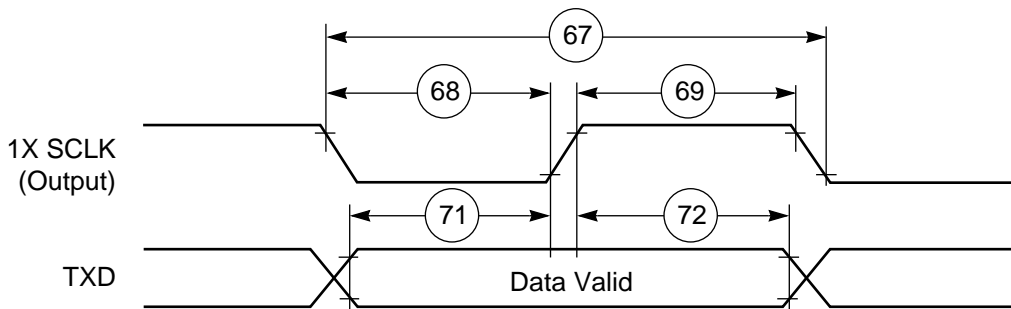

Note: In the Wired-OR mode, TXD can be pulled up by 1 kΩ.

AA0893

Figure 2-18 SCI Asynchronous Mode Timing

SYNCHRONOUS SERIAL INTERFACE (SSI) TIMING

$V_{CC} = 5.0\text{ V} \pm 10\%$ for 27 MHz; $V_{CC} = 5.0\text{ V} \pm 5\%$ for 33 MHz;
 $T_J = -40\text{ to }105^\circ\text{ C}$; $C_L = 50\text{ pF} + 2\text{ TTL loads}$

- t_{SSICC} = SSI clock cycle time
- TXC (SCK Pin) = Transmit Clock
- RXC (SC0 or SCK Pin) = Receive Clock
- FST (SC2 Pin) = Transmit Frame Sync
- FSR (SC1 or SC2 Pin) = Receive Frame Sync
- i ck = Internal Clock
- x ck = External Clock
- g ck = Gated Clock
- i ck a = Internal Clock, Asynchronous mode (Asynchronous implies that STD and SRD are two different clocks)
- i ck s = Internal Clock, Synchronous mode (Synchronous implies that STD and SRD are the same clock)
- bl = bit length
- wl = word length

Table 2-12 SSI Timing

Num	Characteristics	27 MHz		33 MHz		Case	Unit
		Min	Max	Min	Max		
80	Clock Cycle— t_{SSICC} (See Note 1)	$4 \times T_C$	—	$4 \times T_C$	—	—	ns
81	Clock High Period	$4 \times T_C - 15$	—	$4 \times T_C - 13$	—	—	ns
82	Clock Low Period	$4 \times T_C - 15$	—	$4 \times T_C - 13$	—	—	ns
84	SRD Rising Edge to FSR Out (bl) High	—	61	—	48	x ck i ck a	ns
		—	38	—	31		ns
85	SRD Rising Edge to FSR Out (bl) Low	—	54	—	43	xck i ck a	ns
		—	31	—	25		ns
86	SRD Rising Edge to FSR Out (wl) High	—	54	—	43	x ck i ck a	ns
		—	31	—	25		ns
87	RXC Rising Edge to FSR Out (wl) Low	—	54	—	43	x ck i ck a	ns
		—	31	—	25		ns
88	Data In Setup Time Before RXC (SCK in Synchronous Mode)	12	—	10	—	x ck i ck a	ns
		27	—	22	—		ns
	Falling Edge	19	—	16	—	i ck s	ns

Synchronous Serial Interface (SSI) Timing

Table 2-12 SSI Timing (Continued)

Num	Characteristics	27 MHz		33 MHz		Case	Unit
		Min	Max	Min	Max		
89	Data In Hold Time After RXC Falling Edge	27 4	— —	22 4	— —	x ck i ck	ns ns
90	FSR Input (bl) High Before RXC Falling Edge	12 27	— —	10 23	— —	x ck i ck a	ns ns
91	FSR Input (wl) High Before RXC Falling Edge	15 42	— —	13 34	— —	x ck i ck a	ns ns
92	FSR Input Hold Time After RXC Falling Edge	27 4	— —	22 4	— —	x ck i ck	ns ns
93	Flags Input Setup Before RXC Falling Edge	23 39	— —	19 31	— —	x ck i ck s	ns ns
94	Flags Input Hold Time After RXC Falling Edge	27 4	— —	22 4	— —	x ck i ck s	ns ns
95	TXC Rising Edge to FST Out (bl) High	— —	54 23	— —	43 19	x ck i ck	ns ns
96	TXC Rising Edge to FST Out (bl) Low	— —	50 27	— —	40 22	x ck i ck	ns ns
97	TXC Rising Edge to FST Out (wl) High	— —	50 27	— —	40 22	x ck i ck	ns ns
98	TXC Rising Edge to FST Out (wl) Low	— —	50 27	— —	40 22	x ck i ck	ns ns
99	TXC Rising Edge to Data Out Enable from High Impedance	—	50 31	—	40 25	x ck i ck	ns ns
100	TXC Rising Edge to Data Out Valid	—	50 31	—	40 25	x ck i ck	ns ns
101	TXC Rising Edge to Data Out High Impedance (See Note 2)	— —	54 31	— —	43 25	x ck i ck	ns ns
101A	TXC Falling Edge to Data Out High Impedance (See Note 2)	—	$T_C + T_H$	—	$T_C + T_H$	g ck	ns

Freescale Semiconductor, Inc.

Table 2-12 SSI Timing (Continued)

Num	Characteristics	27 MHz		33 MHz		Case	Unit
		Min	Max	Min	Max		
102	FST Input (bl) Setup Time Before TXC Falling Edge	12 27	—	10 23	—	x ck i ck	ns ns
103	FST Input (wl) to Data Out Enable from High Impedance	—	46	—	37		ns
104	FST Input (wl) Setup Time Before TXC Falling Edge	15 42	— —	13 34	— —	x ck i ck	ns ns
105	FST Input Hold Time After TXC Falling Edge	27 4	— —	22 4	— —	x ck i ck	ns ns
106	Flag Output Valid After TXC Rising Edge	— —	54 31	— —	43 25	x ck i ck	ns ns
Note: 1. For internal clock, External Clock Cycle is defined by I_{cyc} and SSI control register. 2. Periodically sampled and not 100% tested							

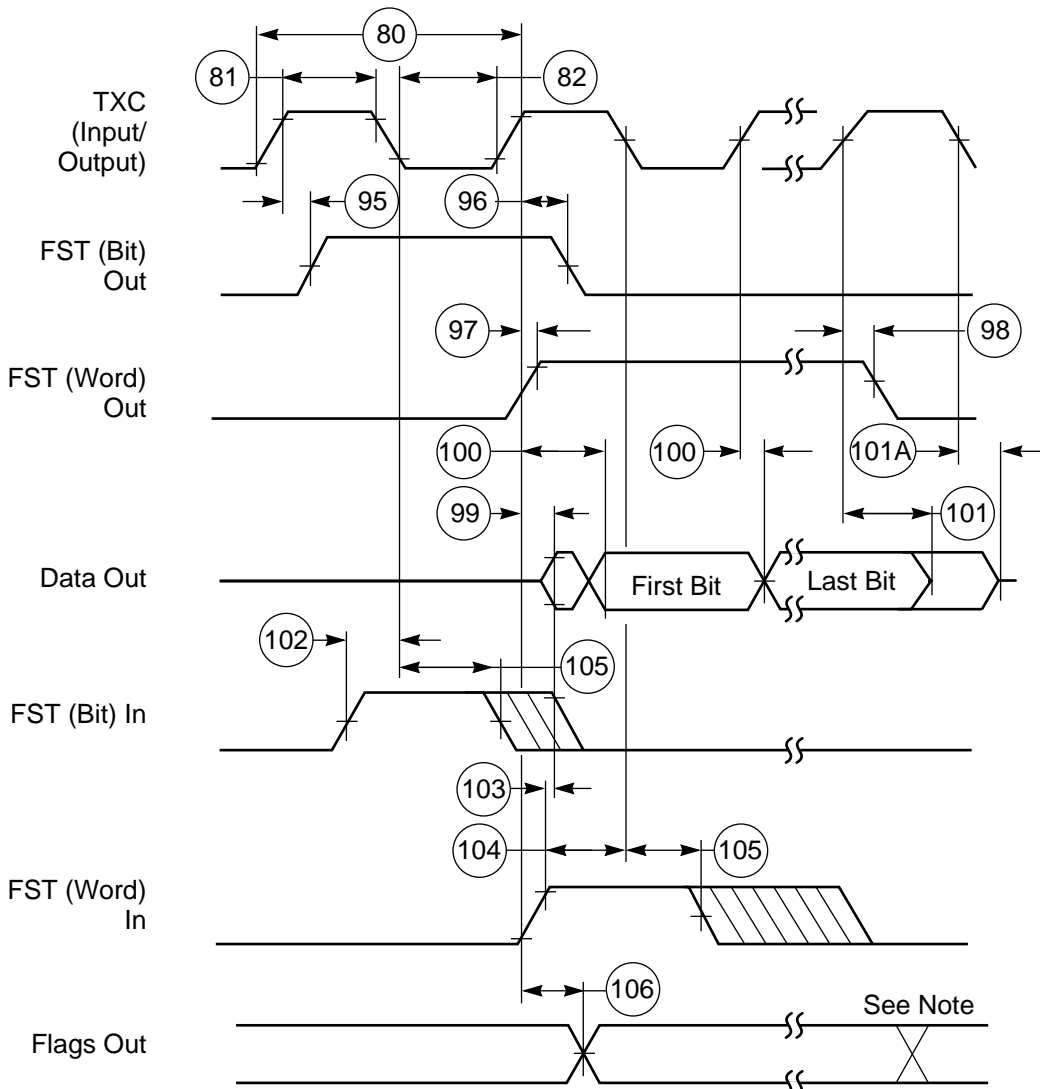

Note: In the Network mode, output flag transitions can occur at the start of each time slot within the frame. In the Normal mode, the output flag state is asserted for the entire frame period.

AA0894

Figure 2-19 SSI Transmitter Timing

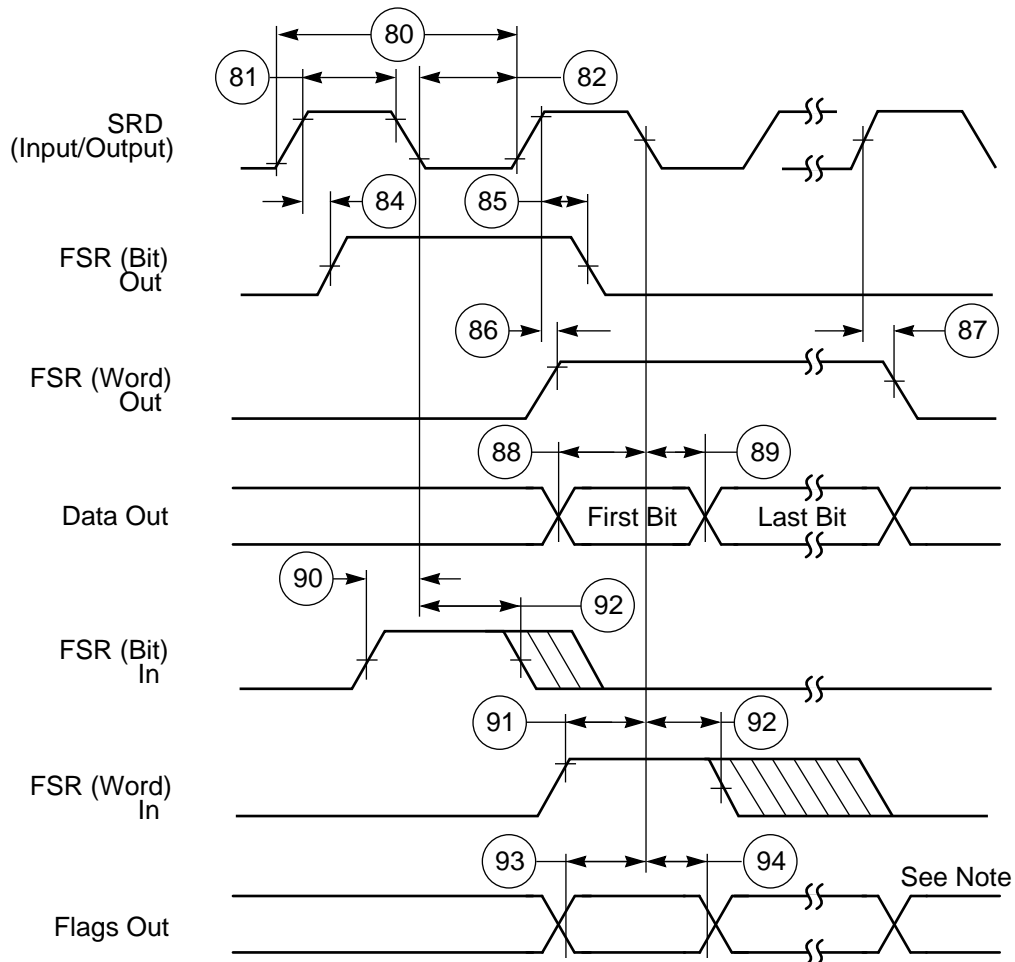

Note: In the Network mode, output flag transitions can occur at the start of each time slot within the frame. In the Normal mode, the output flag state is asserted for the entire frame period.

AA0895

Figure 2-20 SSI Receiver Timing

EXTERNAL BUS ASYNCHRONOUS TIMING

$V_{CC} = 5.0\text{ V} \pm 10\%$ for 27 MHz; $V_{CC} = 5.0\text{ V} \pm 5\%$ for 33 MHz;

$T_J = -40\text{ to }105\text{ }^\circ\text{C}$; $C_L = 50\text{ pF} + 1\text{ TTL loads}$

WS = Number of Wait States, as determined by BCR (WS = 0 to 15)

Capacitance Derating: The DSP56001A external bus timing specifications are designed and tested at the maximum capacitive load of 50 pF, including stray capacitance. Typically, the drive capability of the external bus pins (A0-A15, D0-D23, \overline{PS} , \overline{DS} , \overline{RD} , \overline{WR} , X/Y) derates linearly at 1 ns per 12 pF of additional capacitance from 50 pF to 250 pF of loading. Port B and C pins (HI, SCI, SSI) derate linearly at 1 ns per 5 pF of additional capacitance from 50 pF to 250 pF of loading. Active low lines should be pulled up in a manner consistent with the AC and DC specifications.

Table 2-13 External Bus Asynchronous Timing

No.	Characteristics	27 MHz		33 MHz		Unit
		Min	Max	Min	Max	
115	Delay from \overline{BR} Assertion to \overline{BG} Assertion					
	• With no external access from the DSP	$2 \times T_C + T_H$	$4 \times T_C + T_H + 15$	$2 \times T_C + T_H$	$4 \times T_C + T_H + 13$	ns
	• During external read or write access	$T_C + T_H$	$4 \times T_C + T_H + T_C \times WS + 15$	$T_C + T_H$	$4 \times T_C + T_H + T_C \times WS + 13$	ns
	• During external read-modify-write access	$T_C + T_H$	$6 \times T_C + T_H + 2 \times T_C \times WS + 15$	$T_C + T_H$	$6 \times T_C + T_H + 2 \times T_C \times WS + 13$	ns
	• During Stop mode—external bus will not be released and \overline{BG} will not go low	—	—	—	—	ns
• During Wait mode	$T_H + 3$	$T_C + T_H + 23$	$T_H + 3$	$T_C + T_H + 19$	ns	
116	Delay from \overline{BR} Deassertion to \overline{BG} Deassertion	$2 \times T_C$	$4 \times T_C + 15$	$2 \times T_C$	$4 \times T_C + 13$	ns
117	\overline{BG} Deassertion Duration	$2 \times T_C + T_H - 8$	—	$2 \times T_C + T_H - 6$	—	ns
118	Delay from Address, Data, and Control Bus High Impedance to \overline{BG} Assertion	0	—	0	—	ns

Table 2-13 External Bus Asynchronous Timing (Continued)

No.	Characteristics	27 MHz		33 MHz		Unit
		Min	Max	Min	Max	
119	Delay from \overline{BG} Deassertion to Address and Control Bus Enabled	0	T_{H-8}	0	T_{H-6}	ns
120	Address Valid to \overline{WR} Assertion • $WS = 0$ • $WS > 0$	$T_L - 7$	$T_L + 5$	$T_L - 5.5$	$T_L + 5$	ns
		$T_C - 7$	$T_C + 5$	$T_C - 5.5$	$T_C + 5$	ns
121	\overline{WR} Assertion Width • $WS = 0$ • $WS > 0$	$T_C - 7$	—	$T_C - 5$	—	ns
		$WS \times T_C + T_L - 7$	—	$WS \times T_C + T_L - 5$	—	ns
122	\overline{WR} Deassertion to Address Not Valid	$T_H - 9$	—	$T_H - 7.5$	—	ns
123	\overline{WR} Assertion to Data Out Active From High Impedance • $WS = 0$ • $WS > 0$	$T_H - 7$	$T_H + 8$	$T_H - 5.5$	$T_H + 6.5$	ns
		0	8	0	6.5	ns
124	Data Out Hold Time from \overline{WR} Deassertion (the maximum specification is periodically sampled, and not 100% tested)	$T_H - 7$	$T_H + 6$	$T_H - 5.5$	$T_H + 4.5$	ns
125	Data Out Setup Time to \overline{WR} Deassertion • $WS = 0$ • $WS > 0$	$T_L - 5$	—	$T_L - 5$	—	ns
		$WS \times T_C + T_L - 5$	—	$WS \times T_C + T_L - 5$	—	ns
126	\overline{RD} Deassertion to Address Not Valid	$T_H - 7$	—	$T_H - 5.5$	—	ns
127	Address Valid to \overline{RD} Deassertion • $WS = 0$ • $WS > 0$	$T_C + T_L - 6$	—	$T_C + T_L - 6$	—	ns
		$(WS + 1) \times T_C + T_L - 6$	—	$(WS + 1) \times T_C + T_L - 6$	—	ns

Table 2-13 External Bus Asynchronous Timing (Continued)

No.	Characteristics	27 MHz		33 MHz		Unit
		Min	Max	Min	Max	
128	Input Data Hold Time to \overline{RD} Deassertion	0	—	0	—	ns
129	\overline{RD} Assertion Width					
	• WS = 0	$T_C - 7$	—	$T_C - 5.5$	—	ns
	• WS > 0	$(WS + 1) \times T_C - 7$	—	$(WS + 1) \times T_C - 5.5$	—	ns
130	Address Valid to Input Data Valid					
	• WS = 0	—	$T_C + T_L - 14$	—	$T_C + T_L - 11$	ns
	• WS > 0	—	$(WS + 1) \times T_C + T_L - 14$	—	$(WS + 1) \times T_C + T_L - 11$	ns
131	Address Valid to \overline{RD} Assertion	$T_L - 7$	$T_L + 5$	$T_L - 5.5$	$T_L + 5$	ns
132	\overline{RD} Assertion to Input Data Valid					
	• WS = 0	—	$T_C - 11$	—	$T_C - 9$	ns
	• WS > 0	—	$(WS + 1) \times T_C - 11$	—	$(WS + 1) \times T_C - 9$	ns
133	\overline{WR} Deassertion to \overline{RD} Assertion	$T_C - 12$	—	$T_C - 10$	—	ns
134	\overline{RD} Deassertion to \overline{RD} Assertion	$T_C - 8$	—	$T_C - 6.5$	—	ns
135	\overline{WR} Deassertion to \overline{WR} Assertion					
	• WS = 0	$T_C - 12$	—	$T_C - 10$	—	ns
	• WS > 0	$T_C + T_H - 12$	—	$T_C + T_H - 10$	—	ns
136	\overline{RD} Deassertion to \overline{WR} Assertion					
	• WS = 0	$T_C - 8$	—	$T_C - 6.5$	—	ns
	• WS > 0	$T_C + T_H - 8$	—	$T_C + T_H - 6.5$	—	ns

Freescale Semiconductor, Inc.

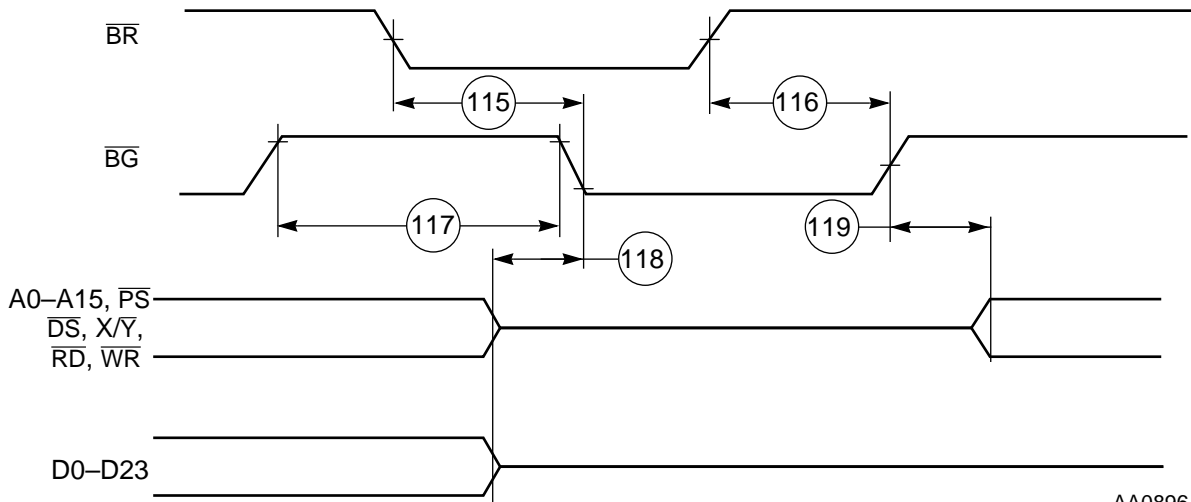

AA0896

Figure 2-21 Bus Request / Bus Grant Timing

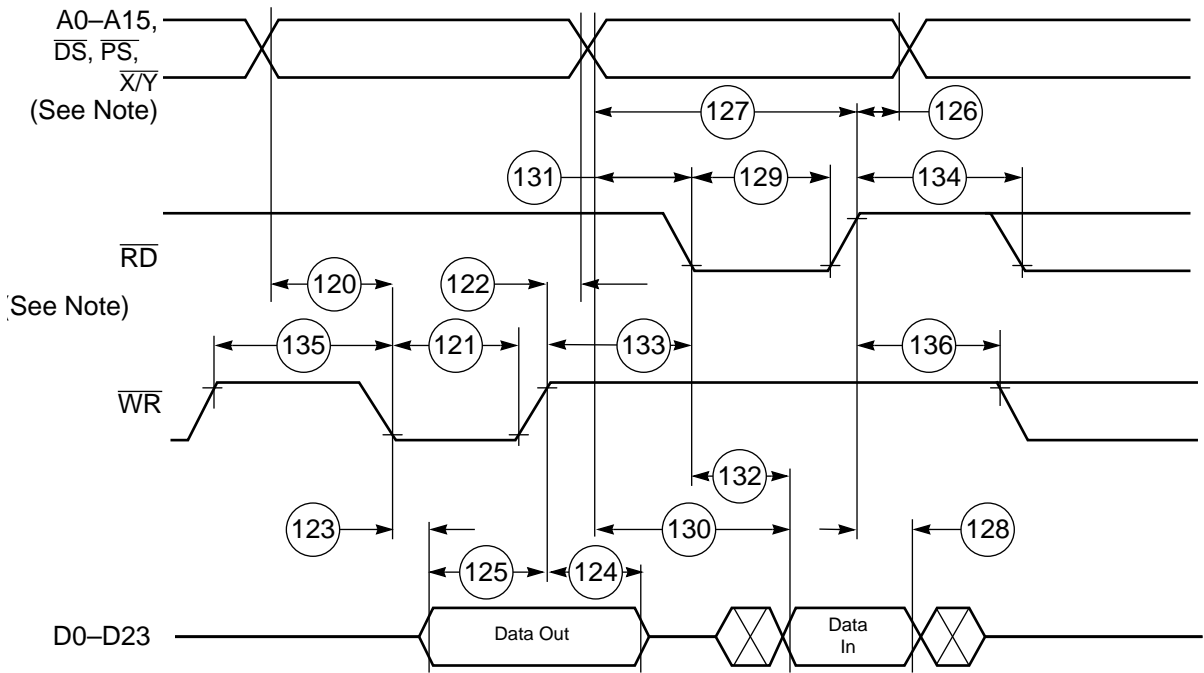

Note: During Read-Modify-Write instructions, the address lines do not change state.

AA0393

Figure 2-22 External Bus Asynchronous Timing

EXTERNAL BUS SYNCHRONOUS TIMING

$V_{CC} = 5.0\text{ V} \pm 10\%$ for 27 MHz, $V_{CC} = 5.0\text{ Vdc} \pm 5\%$ for 33 MHz,
 $T_j = -40^\circ$ to $+105^\circ\text{ C}$, $C_L = 50\text{ pF} + 1\text{ TTL loads}$

Capacitance Derating: The DSP56001A external bus timing specifications are designed and tested at the maximum capacitive load of 50 pF, including stray capacitance. Typically, the drive capability of the external bus pins (A0–A15, D0–D23, \overline{PS} , \overline{DS} , \overline{RD} , \overline{WR} , X/Y) derates linearly at 1 ns per 12 pF of additional capacitance from 50 pF to 250 pF of loading. Port B and C pins (HI, SCI, SSI) derate linearly at 1 ns per 5 pF of additional capacitance from 50 pF to 250 pF of loading. Active-low lines should be pulled up in a manner consistent with the AC and DC specifications.

Table 2-14 External Bus Synchronous Timing

Num	Characteristics	27 MHz		33 MHz		Unit
		Min	Max	Min	Max	
140	Clk Low transition to Address Valid	—	19	—	19	ns
141	Clk High transition to \overline{WR} Assertion(See Note 1, 2) <ul style="list-style-type: none"> • WS=0 • WS>0 	0	17	0	17	ns
		0	$T_H + 17$	0	$T_H + 17$	ns
142	Clk High transition to \overline{WR} Deassertion	5	16	5	13	ns
143	Clk High transition to \overline{RD} Assertion	0	16	0	16	ns
144	Clk High transition to \overline{RD} Deassertion	3	13	3	10.5	ns
145	Clk Low transition to Data-Out Valid	—	19	—	19	ns
146	Clk Low transition to Data-Out Invalid (See Note 3)	4	—	3.5	—	ns
147	Data-In Valid to Clk High transition (Setup)	4	—	4	—	ns
148	Clk High transition to Data-In Invalid (Hold)	12	—	12	—	ns
149	Clk Low transition to Address Invalid (See Note 3)	2	—	2	—	ns

Table 2-14 External Bus Synchronous Timing (Continued)

Num	Characteristics	27 MHz		33 MHz		Unit
		Min	Max	Min	Max	
Note:	1. AC timing specifications which are referenced to a device input signal are measured in production with respect to the 50% point of the respective input signal's transition. 2. WS are wait state values specified in the BCR. 3. Clk Low transition to data-out invalid (specification # T146) and Clk Low transition to address invalid (specification # T149) indicate the time after which data/address are no longer guaranteed to be valid. 4. Timings are given from Clk midpoint to V_{OL} or V_{OH} of the corresponding signal(s).					

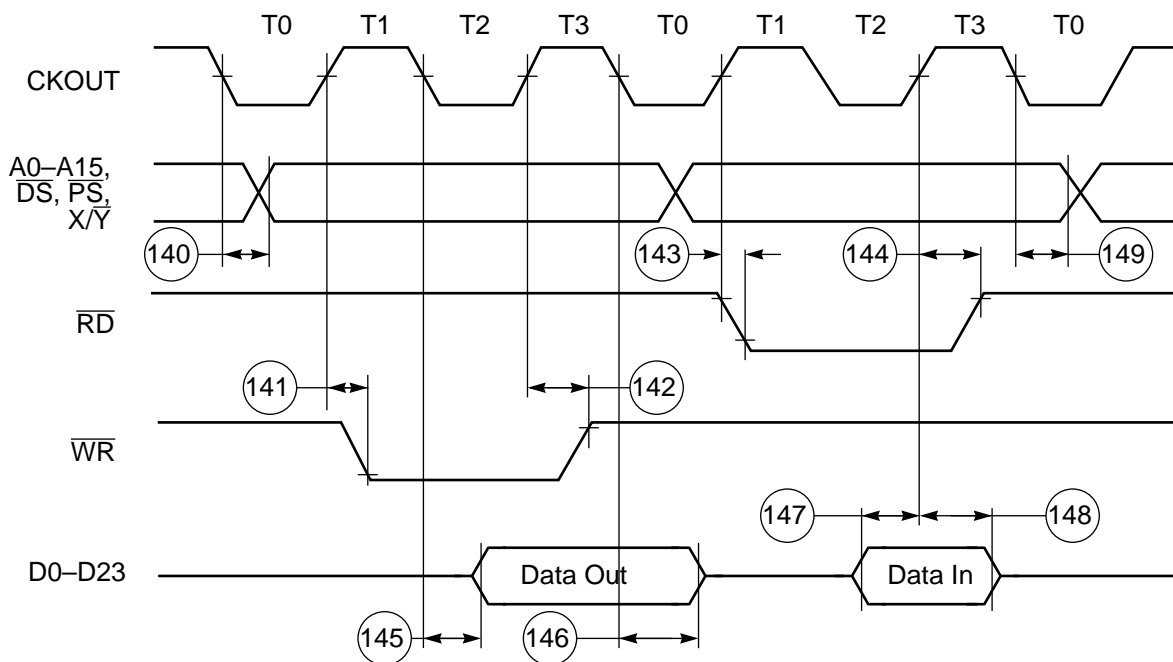

Note: During Read-Modify-Write Instructions, the address lines do not change states. AA0395

Figure 2-23 Synchronous Bus Timing

BUS STROBE / WAIT TIMING

$V_{CC} = 5.0\text{ V} \pm 10\%$ for 27 MHz; $V_{CC} = 5.0\text{ V} \pm 5\%$ for 33 MHz;
 $T_J = -40\text{ to }105^\circ\text{ C}$; $C_L = 50\text{ pF} + 2\text{ TTL loads}$

Table 2-15 Bus Strobe / Wait Timing

No.	Characteristics	27 MHz		33 MHz		Unit
		Min	Max	Min	Max	
150	First CKOUT transition to \overline{BS} Assertion	3	19	2.5	19	ns
151	\overline{WT} Assertion to first CKOUT transition (setup time)	3	—	2.5	—	ns
152	First CKOUT transition to \overline{WT} Deassertion for Minimum Timing	11	$T_C - 6$	12	$T_C - 5$	ns
153	\overline{WT} Deassertion to first CKOUT transition for Maximum Timing (2 wait states)	6	—	5	—	ns
154	Second CKOUT transition to \overline{BS} Deassertion	3	20	3	19	ns
155	\overline{BS} Assertion to Address Valid	-2	8	-2	6.5	ns
156	\overline{BS} Assertion to \overline{WT} Assertion (See Note 1)	0	$T_C - 11$	0	$T_C - 10$	ns
157	\overline{BS} Assertion to \overline{WT} Deassertion (See Note 1 and Note 3) <ul style="list-style-type: none"> • $WS \leq 2$ • $WS \geq 2$ 	T_C	$2 \times T_C - 11$	$T_C + 4$	$2 \times T_C - 10$	ns
		$(WS - 1) \times T_C$	$WS \times T_C - 11$	$(WS - 1) \times T_C + 4$	$WS \times T_C - 10$	ns
158	\overline{WT} Deassertion to \overline{BS} Deassertion	$T_C + T_L$	$2 \times T_C + T_L + 17$	$T_C + T_L$	$2 \times T_C + T_L + 15$	ns
159	Minimum \overline{BS} Deassertion Width for Consecutive External Accesses	$T_H - 6$	—	$T_H - 4.5$	—	ns
160	\overline{BS} Deassertion to Address Invalid (See Note 2)	$T_H - 8$	—	$T_H - 6.5$	—	ns

Table 2-15 Bus Strobe / Wait Timing (Continued)

No.	Characteristics	27 MHz		33 MHz		Unit
		Min	Max	Min	Max	
161	Data-In Valid to \overline{RD} Deassertion (Set Up)	12	—	10	—	ns

Note:

1. If wait states are also inserted using the BCR and if the number of wait states is greater than two, then specification numbers T156 and T157 can be increased accordingly.
2. \overline{BS} deassertion to address invalid indicates the time after which the address are no longer guaranteed to be valid.
3. The minimum number of wait states when using $\overline{BS}/\overline{WT}$ is two (2).
4. For read-modify-write instructions, the address lines will not change states between the read and the write cycle. However, \overline{BS} will deassert before asserting again for the write cycle. If wait states are desired for each of the read and write cycle, the \overline{WT} pin must be asserted once for each cycle.

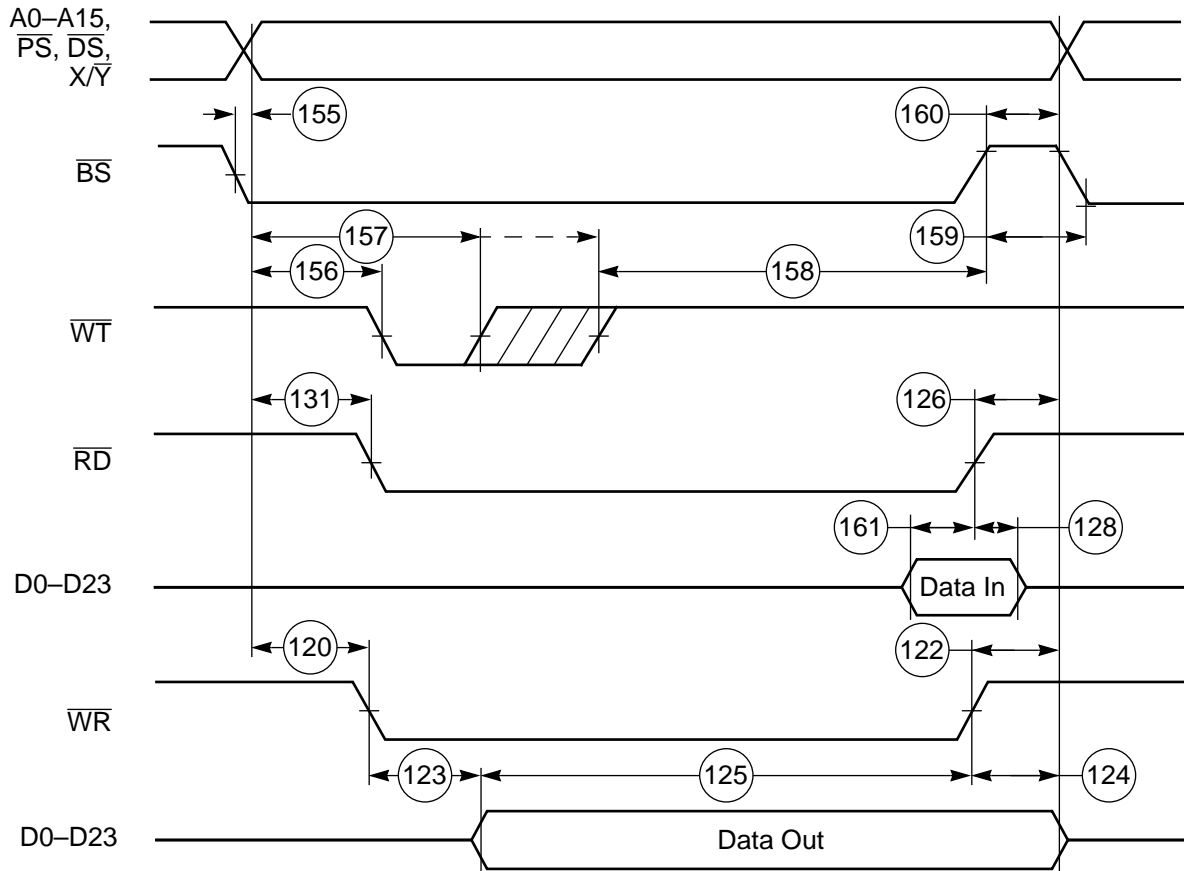

Note: During Read-Modify-Write instructions, the address lines do not change state. However, \overline{BS} will deassert before asserting again for the write cycle.

AA0398

Figure 2-24 Asynchronous \overline{BS} / \overline{WT} Timings

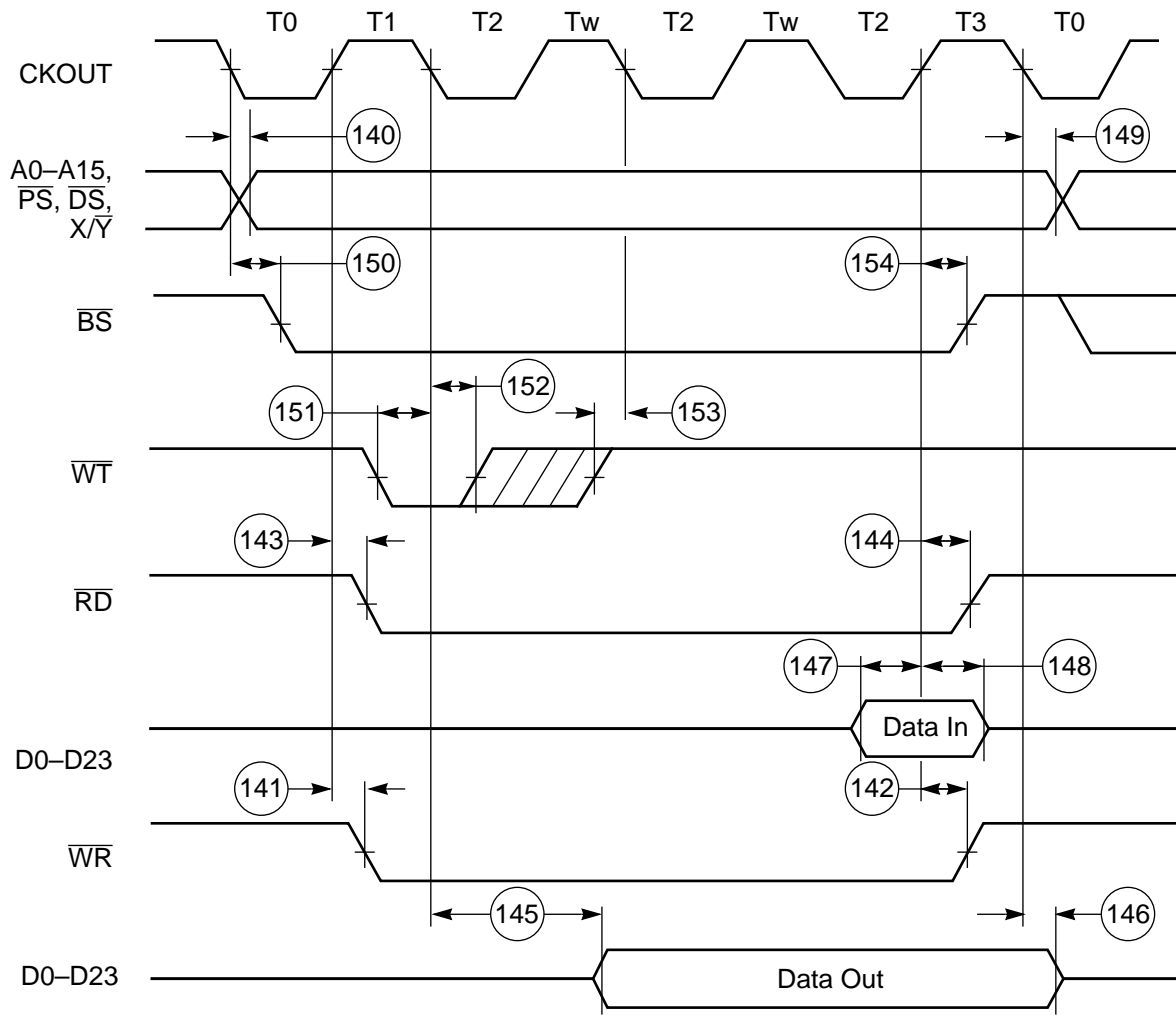

Note: During Read-Modify-Write Instructions, the address lines do not change state. However, \overline{BS} will deassert before asserting again for the write cycle.

AA0397

Figure 2-25 Synchronous \overline{BS} / \overline{WT} Timings



SECTION 3

PACKAGING

PIN-OUT AND PACKAGE INFORMATION

This section supplies information about the packages which are available for this product. Diagrams of the pinouts of each package are included, and tables describing the pins allocated to each of the signals described in **Table 3-1** through **Table 3-5**.

The DSP56001A is available in 3 packages:

- 132-pin plastic quad flat pack (PQFP), type 'FC'
- 132-pin ceramic quad flat pack (CQFP), type 'FE'
- 88-pin Pin Grid Array (PGA), type 'RC'

Top and bottom views of the each package are shown, together with their pin-outs.

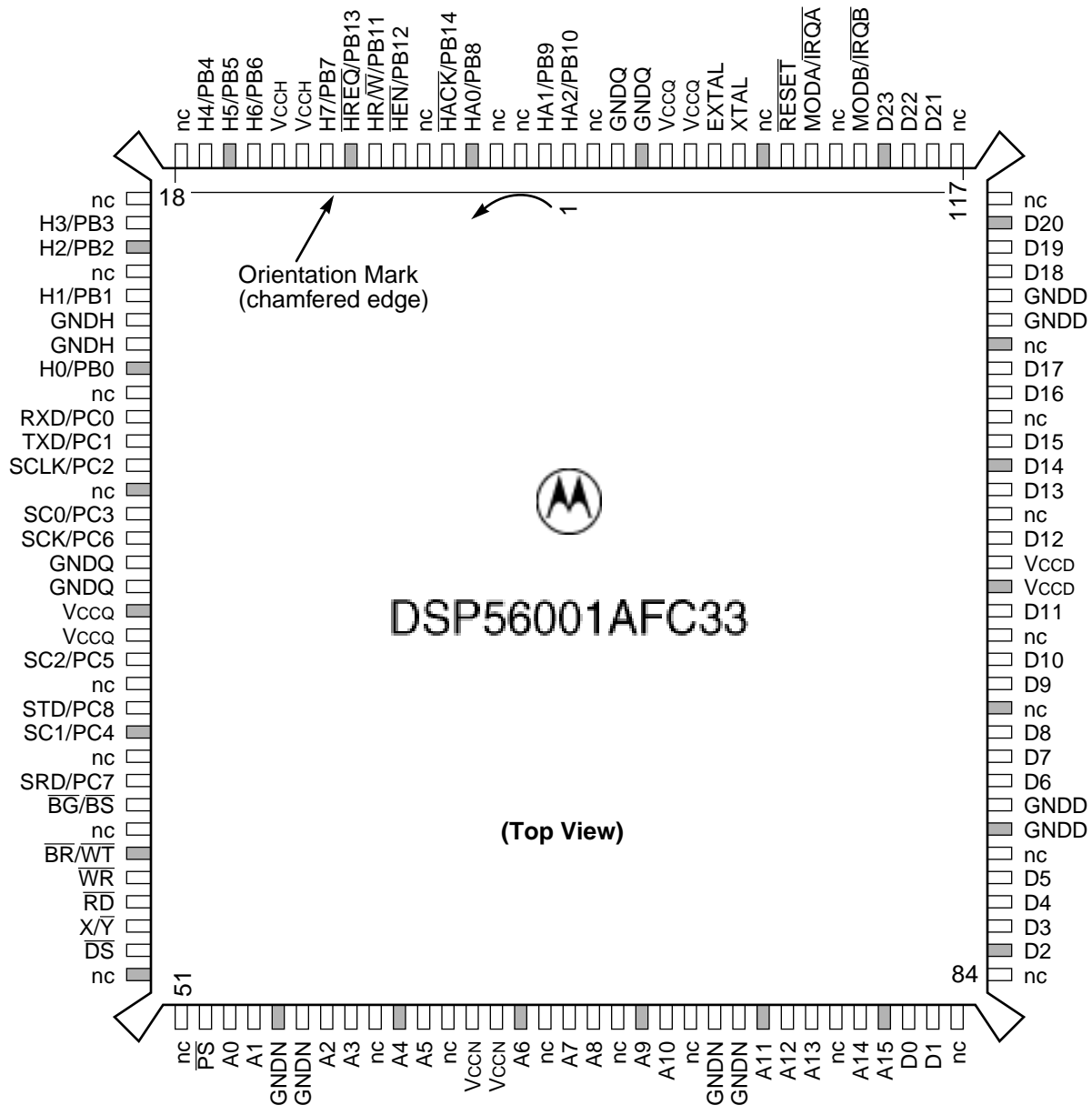

- Note:
1. "nc" are no connection pins that are reserved for possible future enhancements. Do not connect these pins to any power, ground, signal traces, or vias.
 2. An $\overline{\text{O}}$ VERBAR indicates the signal is asserted when the voltage = ground (active low).
 3. To simplify locating the pins, each fifth pin is shaded in the illustration.

AA0898

Figure 3-1 Top View of the 132-pin Plastic (FC) Quad Flat Package

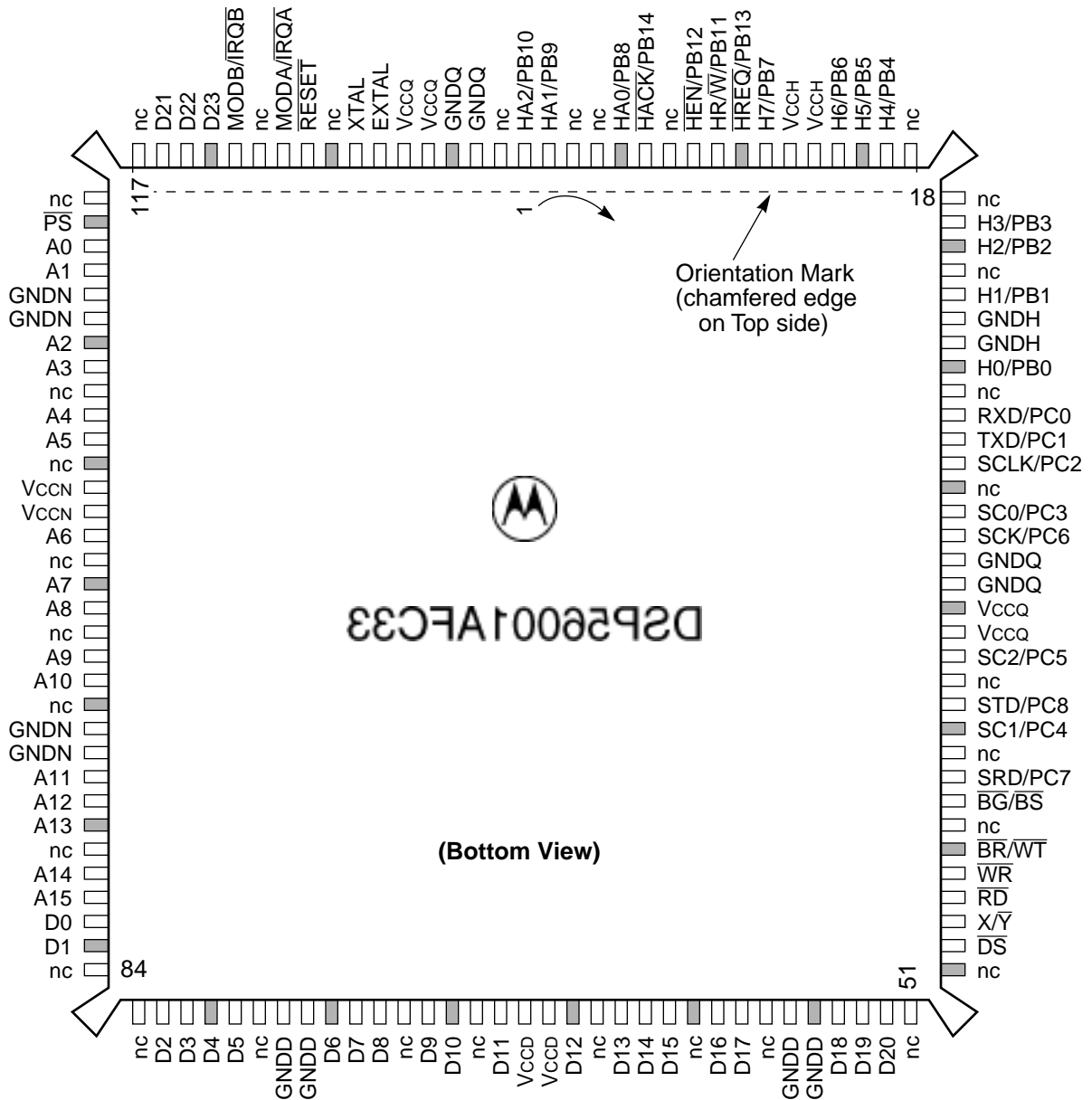

- Note:
1. "nc" are no connection pins that are reserved for possible future enhancements. Do not connect these pins to any power, ground, signal traces, or vias.
 2. An OVERBAR indicates the signal is asserted when the voltage = ground (active low).
 3. To simplify locating the pins, each fifth pin is shaded in the illustration.

AA0899

Figure 3-2 Bottom View of the 132-pin Plastic (FC) Quad Flat Package

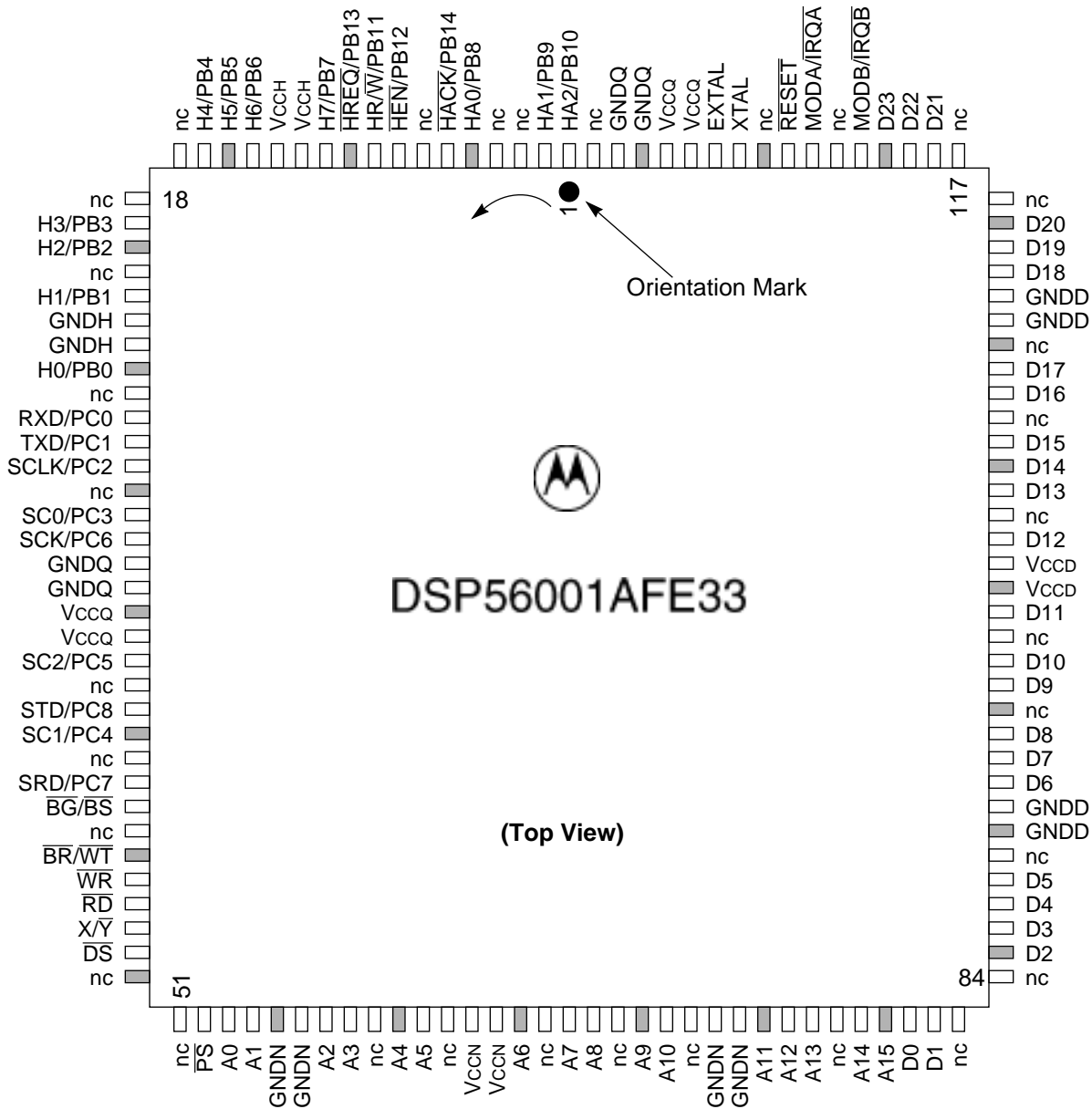

- Note: 1. "nc" are no connection pins that are reserved for possible future enhancements. Do not connect these pins to any power, ground, signal traces, or vias.
 2. An OVERBAR indicates the signal is asserted when the voltage = ground (active low).
 3. To simplify locating the pins, each fifth pin is shaded in the illustration.

AA0900

Figure 3-3 Top View of the 132-pin Ceramic (FE) Quad Flat Package

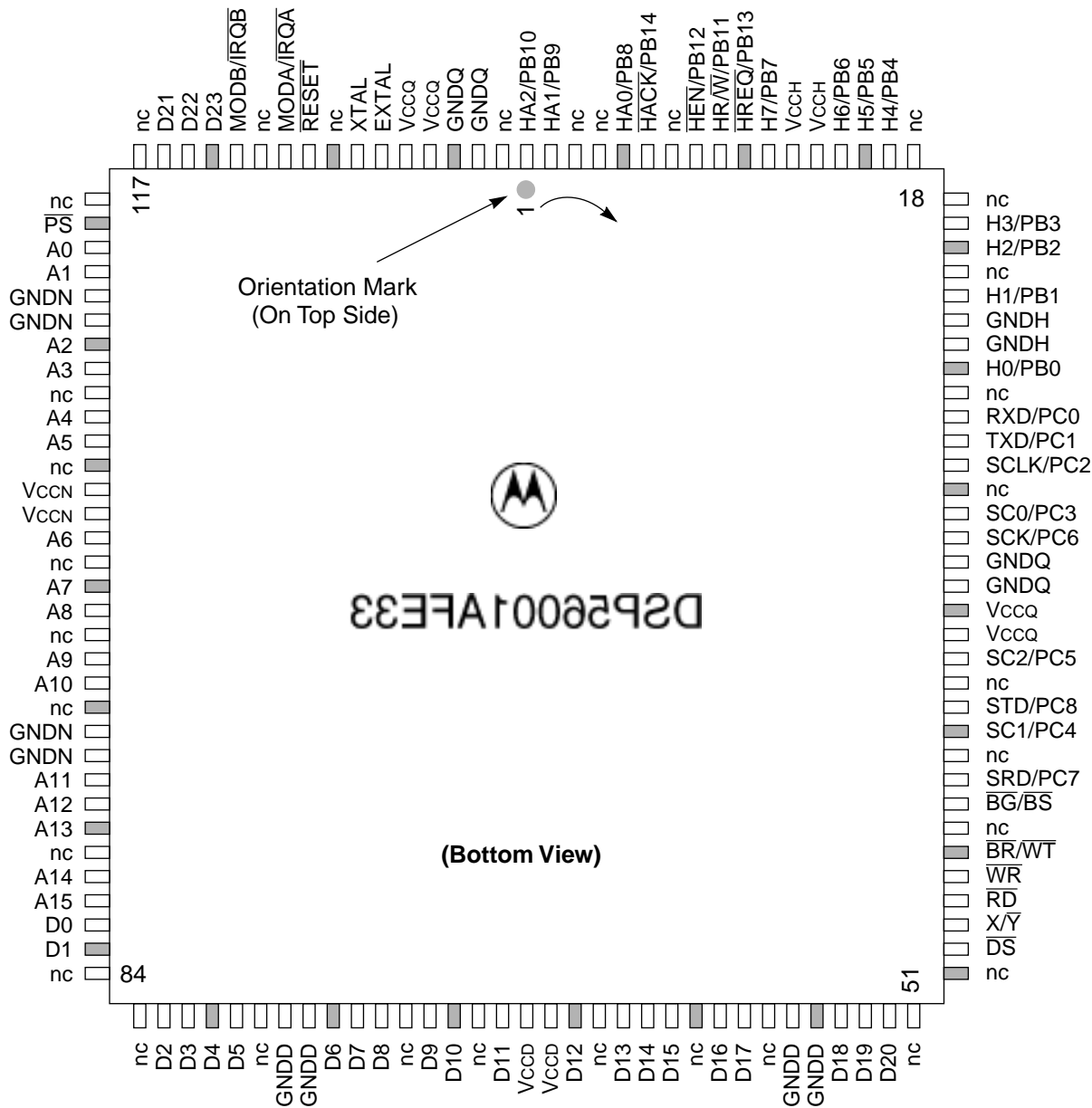

- Note:
1. "nc" are no connection pins that are reserved for possible future enhancements. Do not connect these pins to any power, ground, signal traces, or vias.
 2. An OVERBAR indicates the signal is asserted when the voltage = ground (active low).
 3. To simplify locating the pins, each fifth pin is shaded in the illustration.

AA0901

Figure 3-4 Bottom View of the 132-pin Ceramic (FE) Quad Flat Package

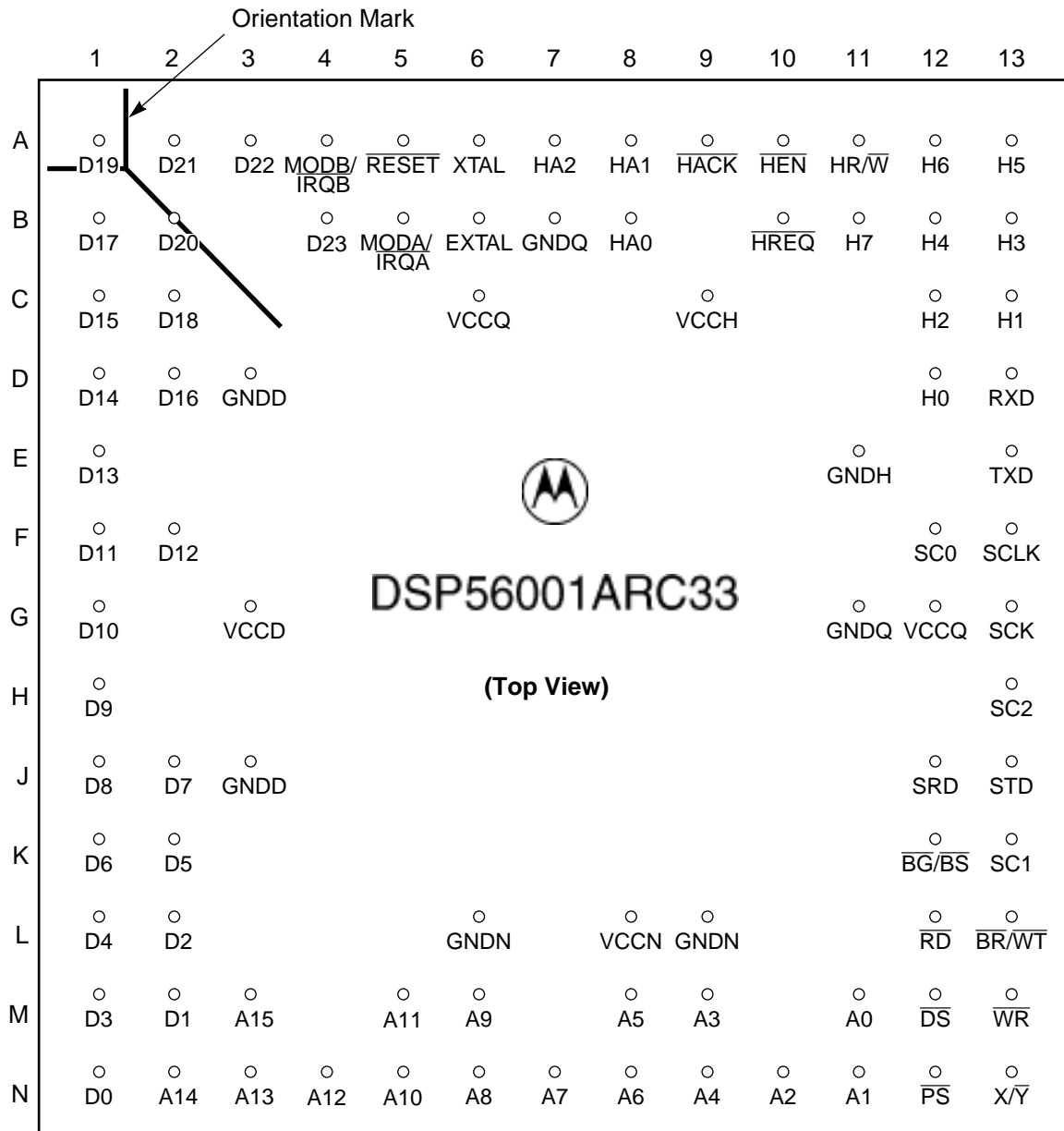

- Note:
1. "nc" are no connection pins that are reserved for possible future enhancements. Do not connect these pins to any power, ground, signal traces, or vias.
 2. An $\overline{\text{OVERBAR}}$ indicates the signal is asserted when the voltage = ground (active low).
 3. To simplify locating the pins, each fifth pin is shaded in the illustration.

AA0902

Figure 3-5 Top View of the 88-pin Ceramic (RC) Pin Grid Array Package

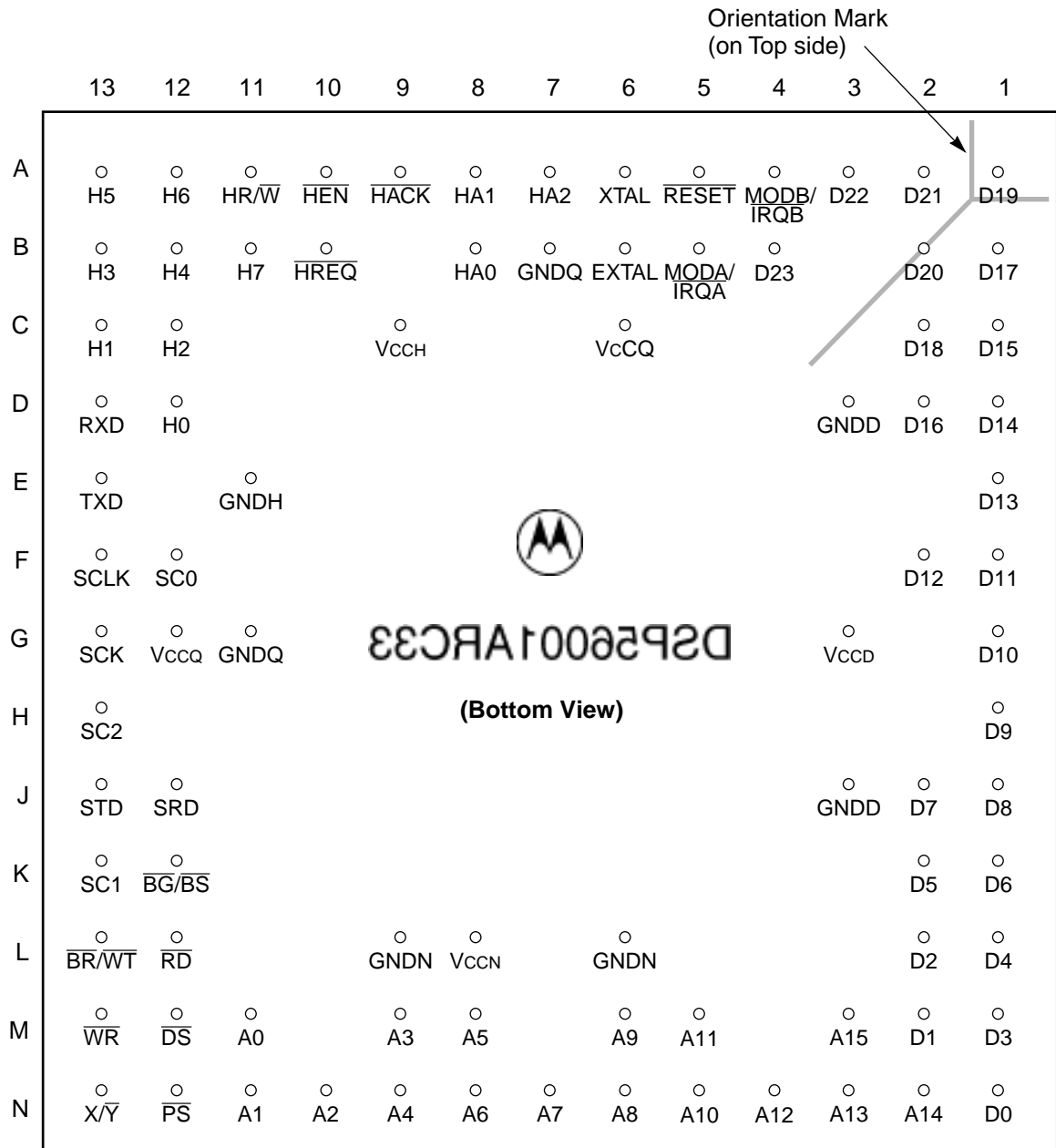

- Note:
1. "nc" are no connection pins that are reserved for possible future enhancements. Do not connect these pins to any power, ground, signal traces, or vias.
 2. An $\overline{\text{O}}$ VERBAR indicates the signal is asserted when the voltage = ground (active low).
 3. To simplify locating the pins, each fifth pin is shaded in the illustration.
- AA0903

Figure 3-6 Bottom View of the 88-pin Ceramic (RC) Pin Grid Array Package

Pin-out and Package Information

The DSP56001A signals that may be programmed as General Purpose I/O are listed with their primary function in **Table 3-1**.

Table 3-1 DSP56001A General Purpose I/O Pin Identification

Pin Number 132 pin "FC" PQFP "FE" CQFP	Pin Number 88 pin "RC" PGA	Primary Function	Port	GPIO ID
25	D12	H0	B	PB0
22	C13	H1		PB1
20	C12	H2		PB2
19	B13	H3		PB3
16	B12	H4		PB4
15	A13	H5		PB5
14	A12	H6		PB6
11	B11	H7		PB7
5	B8	HA0		PB8
2	A8	HA1		PB9
1	A7	HA2		PB10
9	A11	HR/ \overline{W}		PB11
8	A10	\overline{HEN}		PB12
10	B10	\overline{HREQ}		PB13
6	A9	HACK	PB14	

Table 3-1 DSP56001A General Purpose I/O Pin Identification

Pin Number 132 pin "FC" PQFP "FE" CQFP	Pin Number 88 pin "RC" PGA	Primary Function	Port	GPIO ID
27	D13	RXD	C	PC0
28	E13	TXD		PC1
29	F13	SCLK		PC2
31	F12	SC0		PC3
40	K13	SC1		PC4
37	H13	SC2		PC5
32	G13	SCK		PC6
42	J12	SRD		PC7
39	J13	STD		PC8

Table 3-2 DSP56001A Signal Identification by Pin Number — PGA

Pin No.	Signal Name	Pin No.	Signal Name	Pin No.	Signal Name
A1	D19	D1	D14	L6	GNDN
A2	D21	D2	D16	L8	VCCN
A3	D22	D3	GNDD	L9	GNDN
A4	MODB/ $\overline{\text{IRQB}}$	D12	H0/PB0	L12	$\overline{\text{RD}}$
A5	$\overline{\text{RESET}}$	D13	RXD/PC0	L13	$\overline{\text{BR/WT}}$
A6	XTAL	E1	D13	M1	D3
A7	HA2/PB10	E11	GNDH	M2	D1
A8	HA1/PB9	E13	TXD/PC1	M3	A15
A9	$\overline{\text{HACK}}$ /PB14	F1	D11	M5	A11
A10	$\overline{\text{HEN}}$ /PB12	F2	D12	M6	A9
A11	HR/ $\overline{\text{W}}$ /PB11	F12	SC0/PC3	M8	A5

Table 3-2 DSP56001A Signal Identification by Pin Number — PGA

Pin No.	Signal Name	Pin No.	Signal Name	Pin No.	Signal Name
A12	H6/PB6	F13	SCLK/PC2	M9	A3
A13	H5/PB5	G1	D10	M11	A0
B1	D17	G3	VCCD	M12	\overline{DS}
B2	D20	G11	GNDQ	M13	\overline{WR}
B4	D23	G12	VCCQ	N1	D0
B5	MODA/ \overline{IRQA}	G13	SCK/PC6	N2	A14
B6	EXTAL	H1	D9	N3	A13
B7	GNDQ	H13	SC2/PC5	N4	A12
B8	HA0/PB8	J1	D8	N5	A10
B10	\overline{HREQ} /PB13	J2	D7	N6	A8
B11	H7/PB7	J3	GNDD	N7	A7
B12	H4/PB4	J12	SRD/PC7	N8	A6
B13	H3/PB3	J13	STD/PC8	N9	A4
C1	D15	K1	D6	N10	A2
C2	D18	K2	D5	N11	A1
C6	VCCQ	K12	$\overline{BG}/\overline{BS}$	N12	\overline{PS}
C9	VcCH	K13	SC1/PC4	N13	X/ \overline{Y}
C12	H2/PB2	L1	D4	—	—
C13	H1/PB1	L2	D2	—	—

Table 3-3 DSP56001A Signal Identification by Pin Number —PQFP & CQFP

Pin No.	Signal Name	Pin No.	Signal Name	Pin No.	Signal Name
1	HA2/PB10	26	nc	51	nc
2	HA1/PB9	27	RXD/PC0	52	\overline{PS}
3	nc	28	TXD/PC1	53	A0
4	nc	29	SCLK/PC2	54	A1
5	HA0/PB8	30	nc	55	GNDN
6	\overline{HACK} /PB14	31	SC0/PC3	56	GNDN
7	nc	32	SCK/PC6	57	A2
8	\overline{HEN} /PB12	33	GNDQ	58	A3
9	HR/ \overline{W} /PB11	34	GNDQ	59	nc
10	\overline{HREQ} /PB13	35	VCCQ	60	A4
11	H7/PB7	36	VCCQ	61	A5
12	VcCH	37	SC2/PC5	62	nc
13	VcCH	38	nc	63	VCCN
14	H6/PB6	39	STD/PC8	64	VCCN
15	H5/PB5	40	SC1/PC4	65	A6
16	H4/PB4	41	nc	66	nc
17	nc	42	SRD/PC7	67	A7
18	nc	43	$\overline{BG}/\overline{BS}$	68	A8
19	H3/PB3	44	nc	69	nc
20	H2/PB2	45	$\overline{BR}/\overline{WT}$	70	A9
21	nc	46	\overline{WR}	71	A10
22	H1/PB1	47	\overline{RD}	72	nc
23	GNDH	48	X/ \overline{Y}	73	GNDN
24	GNDH	49	\overline{DS}	74	GNDN
25	H0/PB0	50	nc	75	A11

Table 3-3 DSP56001A Signal Identification by Pin Number —PQFP & CQFP

Pin No.	Signal Name	Pin No.	Signal Name	Pin No.	Signal Name
76	A12	95	nc	114	D19
77	A13	96	D9	115	D20
78	nc	97	D10	116	nc
79	A14	98	nc	117	nc
80	A15	99	D11	118	D21
81	D0	100	VCCD	119	D22
82	D1	101	VCCD	120	D23
83	nc	102	D12	121	MODB/ $\overline{\text{IRQB}}$
84	nc	103	nc	122	nc
85	D2	104	D13	123	MODA/ $\overline{\text{IRQA}}$
86	D3	105	D14	124	$\overline{\text{RESET}}$
87	D4	106	D15	125	nc
88	D5	107	nc	126	XTAL
89	nc	108	D16	127	EXTAL
90	GNDD	109	D17	128	VCCQ
91	GNDD	110	nc	129	VCCQ
92	D6	111	GNDD	130	GNDQ
93	D7	112	GNDD	131	GNDQ
94	D8	113	D18	132	nc

Note: 1. "nc" are no connection pins that are reserved for possible future enhancements. Do not connect these pins to any power, ground, signal traces, or vias.
 2. An $\overline{\text{OVERBAR}}$ indicates the signal is asserted when the voltage = ground (active low).

Table 3-4 DSP56001A Identification by Signal Name

Signal Name	132 pin “FC” PQFP or “FE” CQFP Pin No.	88 pin “RC” PGA Pin No.	Signal Name	132 pin “FC” PQFP or “FE” CQFP Pin No.	88 pin “RC” PGA Pin No.
A0	53	M11	D8	94	J1
A1	54	N11	D9	96	H1
A2	57	N10	D10	97	G1
A3	58	M9	D11	99	F1
A4	60	N9	D12	102	F2
A5	61	M8	D13	104	E1
A6	65	N8	D14	105	D1
A7	67	N7	D15	106	C1
A8	68	N6	D16	108	D2
A9	70	M6	D17	109	B1
A10	71	N5	D18	113	C2
A11	75	M5	D19	114	A1
A12	76	N4	D20	115	B2
A13	77	N3	D21	118	A2
A14	79	N2	D22	119	A3
A15	80	M3	D23	120	B4
\overline{BG}	43	K12	\overline{DS}	49	M12
\overline{BR}	45	L13	EXTAL	127	B6
\overline{BS}	43	K12	GNDD	90	D3
D0	81	N1	GNDD	91	J3
D1	82	M2	GNDD	111	
D2	85	L2	GNDD	112	
D3	86	M1	GNDH	23	E11
D4	87	L1	GNDH	24	

Table 3-4 DSP56001A Identification by Signal Name (Continued)

Signal Name	132 pin "FC" PQFP or "FE" CQFP Pin No.	88 pin "RC" PGA Pin No.	Signal Name	132 pin "FC" PQFP or "FE" CQFP Pin No.	88 pin "RC" PGA Pin No.
D5	88	K2	GNDN	55	L6
D6	92	K1	GNDN	56	L9
D7	93	J2	GNDN	73	
GNDN	74		PB2	20	C12
GNDQ	33	B7	PB3	19	B13
GNDQ	34	G11	PB4	16	B12
GNDQ	130		PB5	15	A13
GNDQ	131		PB6	14	A12
H0	25	D12	PB7	11	B11
H1	22	C13	PB8	5	B8
H2	20	C12	PB9	2	A8
H3	19	B13	PB10	1	A7
H4	16	B12	PB11	9	A11
H5	15	A13	PB12	8	A10
H6	14	A12	PB13	10	B10
H7	11	B11	PB14	6	A9
HA0	5	B8	PC0	27	D13
HA1	2	A8	PC1	28	E13
HA2	1	A7	PC2	29	F13
HACK	6	A9	PC3	31	F12
HEN	8	A10	PC4	40	K13
HR/W	9	A11	PC5	37	H13
HREQ	10	B10	PC6	32	G13
IRQA	123	B5	PC7	42	J12

Table 3-4 DSP56001A Identification by Signal Name (Continued)

Signal Name	132 pin "FC" PQFP or "FE" CQFP Pin No.	88 pin "RC" PGA Pin No.	Signal Name	132 pin "FC" PQFP or "FE" CQFP Pin No.	88 pin "RC" PGA Pin No.
\overline{IRQB}	121	A4	PC8	39	J13
MODA	123	B5	\overline{PS}	52	N12
MODB	121	A4	\overline{RD}	47	L12
\overline{NMI}	none	none	\overline{RESET}	124	A5
PB0	25	D12	RXD	27	D13
PB1	22	C13	SC0	31	F12
SC1	40	K13	nc	26	
SC2	37	H13	nc	30	
SCK	32	G13	nc	38	
SCLK	29	F13	nc	41	
SRD	42	J12	nc	44	
STD	39	J13	nc	50	
TXD	28	E13	nc	51	
VCCD	100	G3	nc	59	
VCCD	101		nc	62	
VCCH	12	C9	nc	66	
VCCH	13		nc	69	
VCCN	63	L8	nc	72	
VCCN	64		nc	78	
VCCQ	35	C6	nc	83	
VCCQ	36	G12	nc	84	
VCCQ	128		nc	89	
VCCQ	129		nc	95	
\overline{WR}	46	M13	nc	98	

Table 3-4 DSP56001A Identification by Signal Name (Continued)

Signal Name	132 pin "FC" PQFP or "FE" CQFP Pin No.	88 pin "RC" PGA Pin No.	Signal Name	132 pin "FC" PQFP or "FE" CQFP Pin No.	88 pin "RC" PGA Pin No.
\overline{WT}	45	L13	nc	103	
X/\overline{Y}	48	N13	nc	107	
XTAL	126	A6	nc	110	
nc	3		nc	116	
nc	4		nc	117	
nc	7		nc	122	
nc	17		nc	125	
nc	18		nc	132	
nc	21				

Power and ground pins have special considerations for noise immunity. See the section **Design Considerations**.

Table 3-5 DSP56001A Power Supply Pins

132 pin "FC" PQFP or "FE" CQFP Pin No.	88 pin "RC" PGA Pin No.	Power Supply	Circuit Supplied
63	L8	VCCN	Address Bus Buffers
64			
55	L6	GNDN	
56	L9		
73			
74			

Table 3-5 DSP56001A Power Supply Pins (Continued)

132 pin "FC" PQFP or "FE" CQFP Pin No.	88 pin "RC" PGA Pin No.	Power Supply	Circuit Supplied	
100	G3	VCCD	Data Bus Buffers	
101				
90	D3	GNDD		
91	J3			
111				
112				
35	C6	VCCQ	Internal Logic	
36	G12			
128				
129				
33	B7	GNDQ		
34	G11			
130				
131				
12	C9			VCCH
13		GNDH		Peripherals
23	E11			
24				

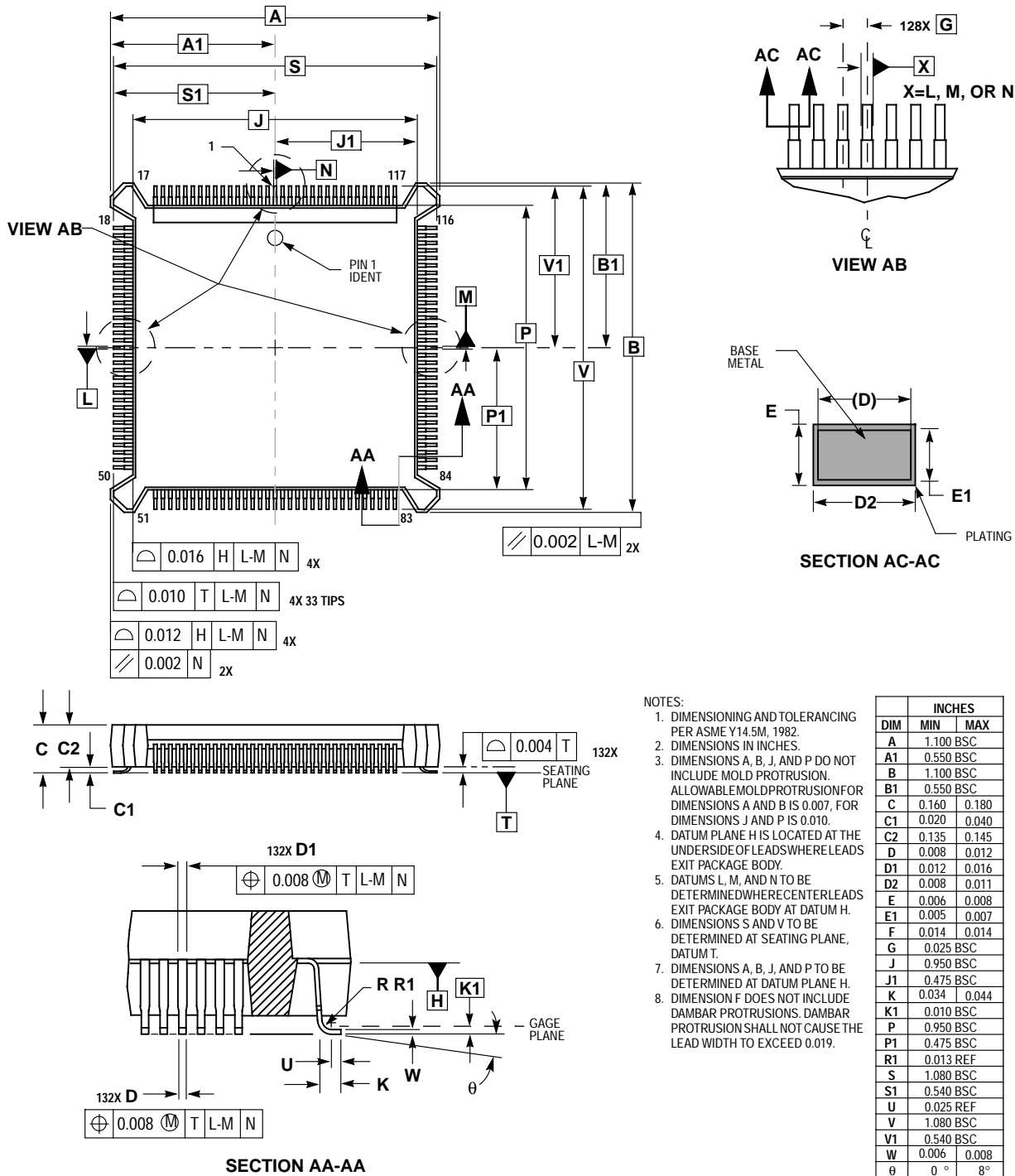

Figure 3-7 132-pin Plastic Quad Flat Pack (PQFP) Mechanical Information

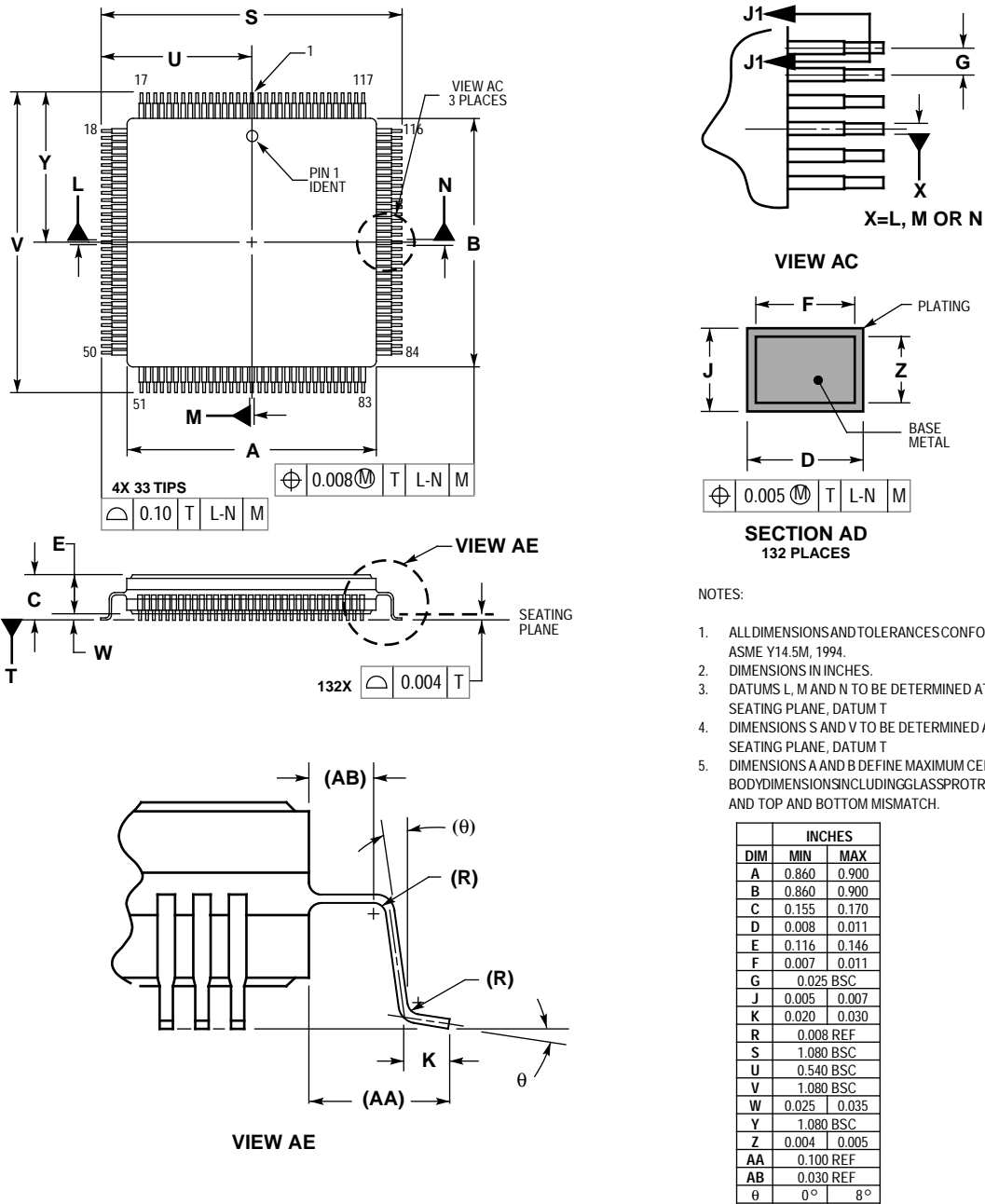

Figure 3-8 132-pin Ceramic Quad Flat Pack (CQFP) Mechanical Information

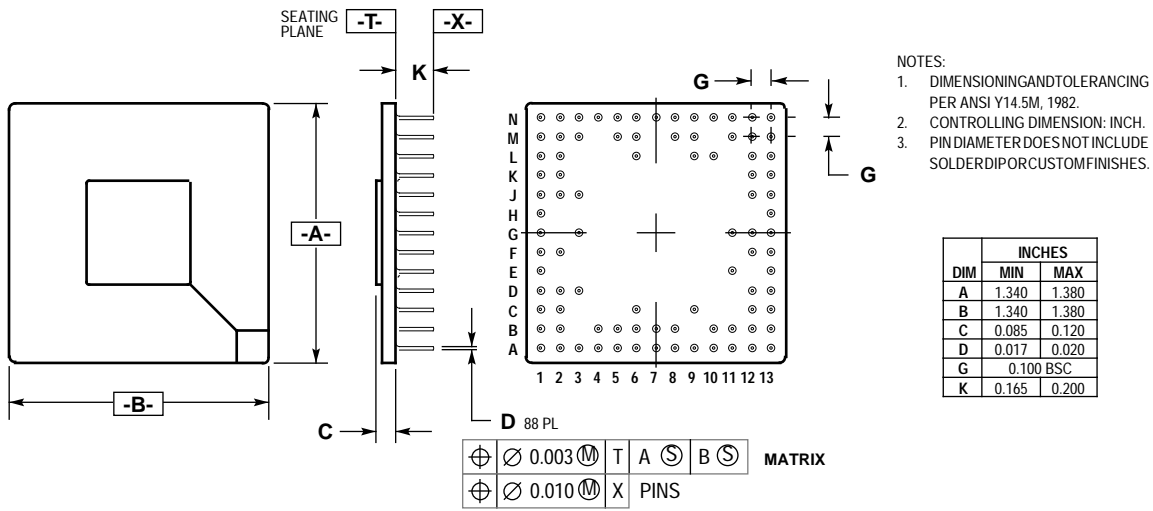
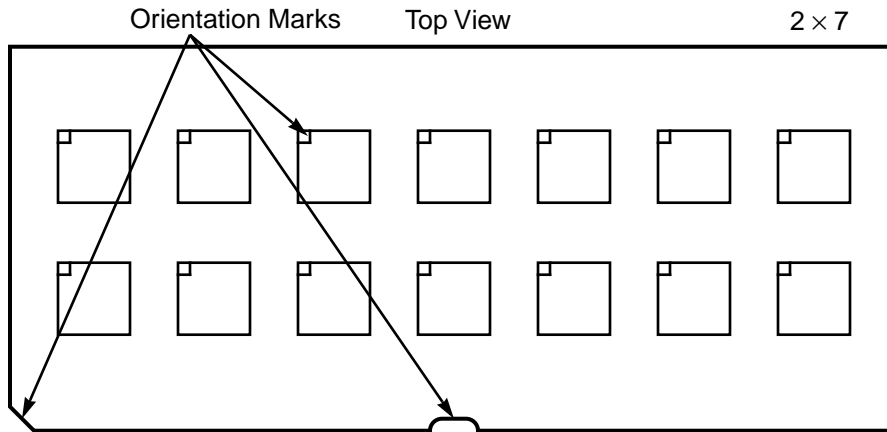
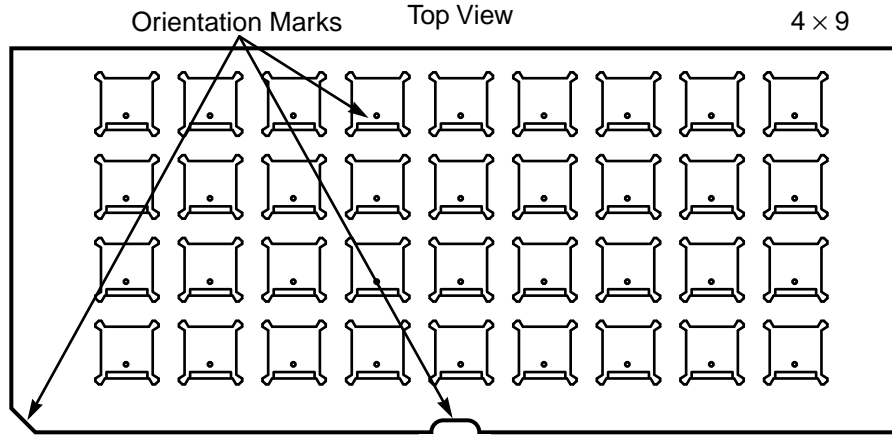

Figure 3-9 88-pin Pin Grid Array (PGA) Mechanical Information



AA0617

Figure 3-10 PGA Shipping Tray



AA1132

Figure 3-11 PQFP Shipping Tray

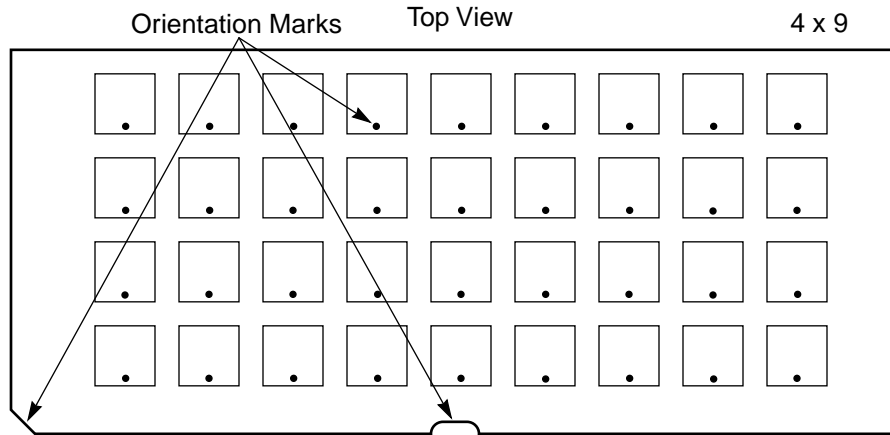

AA0897

Figure 3-12 CQFP Shipping Tray



SECTION 4

DESIGN CONSIDERATIONS

SUBSTITUTING THE DSP56001A FOR THE DSP56001

This section highlights the differences between the DSP56001 and DSP56001A that need to be taken into consideration when substituting the DSP56001A for the DSP56001. New designs should use the DSP56002 due to its enhanced features and speed.

Hardware Considerations

NON-MASKABLE INTERRUPT (NMI)

A Non-Maskable Interrupt (NMI) function was previously accessible on the DSP56001 by applying 10 volts to the MODB/ $\overline{\text{IRQB}}$ pin. The DSP56001A does not support a non-maskable interrupt (NMI).

CAUTION

DO NOT APPLY 10 VOLTS TO ANY PIN OF THE DSP56001A (including MODB)! Subjecting any pin of the DSP56001A to voltages in excess of the specified TTL/CMOS levels will permanently damage the device.

AC ELECTRICAL CHARACTERISTICS

The DSP56001A die utilizes a faster technology than the DSP56001. As a result, many DSP56001A signals exhibit faster rise and fall times than the same signals on the DSP56001. These faster edges may generate more radiated noise and EMI, and may require more attention to these issues (e.g., the DSP56001A based circuit may require better decoupling).

Software/Application Considerations

Software written for the DSP56001 will generally run unmodified on the DSP56001A. There are, however, certain differences which should be noted. Users should consider the impact these differences may have on each application.

AGU MODIFY REGISTERS

Numbers between \$8000 and \$FFFE (inclusive) are not valid values for loading into the modify registers (M0–M7) of the address generation unit on the DSP56001. Certain values within this range, however, enable wrap-around addressing modes on the DSP56001A that are not supported, and inadvertent enabling of these addressing modes may yield unexpected results. Do **not** load the modify registers of the DSP56001A with values from \$8000 to \$FFFE.

RESERVED MEMORY LOCATIONS

Certain memory locations are designated as reserved on the DSP56001. Accesses to these memory locations on the DSP56001A will result in unpredictable processor behavior **including the possibility of halting the processor completely**. In particular, writes to the following X memory locations should be avoided on the DSP56001A:

X:\$FFDE, X:\$FFDF, X:\$FFFC, X:\$FFFD

MOVEP TO RN/NN/MN REGISTERS

On the DSP56001 there is a pipeline delay when using the MOVEP instruction to change the contents of an address register (Mn, Nn, or Rn). The new contents of the destination address register will not be available for use during the following instruction (i.e, there is a single instruction cycle delay).

On the DSP56001A this pipeline delay has been removed. If an address register (Mn, Nn, or Rn) is directly changed with a MOVEP instruction, the updated contents will be available for use during the following instruction. DSP56001 software that depends on this pipeline delay must be modified when moved onto the DSP56001A.

MOVEP TO/FROM DATA ALU REGISTERS

MOVEP instructions to/from Data ALU registers take 2 instruction cycles on the DSP56001. On the DSP56001A, these instructions take only 1 instruction cycle. DSP56001 software which is dependent on the timing of this form of the MOVEP instruction must be modified when ported to the DSP56001A.

Table 4-1 Illegal Instructions

Instruction Symbol	Instruction Name
DEBUG—DO NOT USE	Enter Debug mode
DEBUG _{cc} —DO NOT USE	Enter Debug mode conditionally
DEC	Decrement by one
INC	Increment by one
MAC #iiii	Signed multiply-accumulate immediate
MPY #iiii	Signed multiply immediate
MACR #iiii	Signed multiply-accumulate and round immediate
MPYR #iiii	Signed multiply and round immediate

MOVEP IMMEDIATE

MOVEP Immediate instructions take 3 instruction cycles on the DSP56001. On the DSP56001A, these instructions take only 2 instruction cycles. DSP56001 software that is dependent on the timing of this form of the MOVEP instruction must be modified when ported to the DSP56001A.

ILLEGAL INSTRUCTIONS

The instructions listed in Table 4-1 will *not* generate an illegal instruction interrupt on the DSP56001A. None of these instructions are tested on the DSP56001A and should *not* be used.

Note: The DEBUG and DEBUG_{cc} instructions are microcoded on the DSP56001A, but the peripherals necessary to make use of this instruction are not available. Any use of the DEBUG or DEBUG_{cc} instructions will completely halt the processor. The processor will exit this state only on reset.

STOP/WAIT TIMING

Wake-up from the Stop and Wait operating modes with \overline{IRQA} and \overline{IRQB} is longer on the DSP56001A by one T_c period.

SCI/SSI INITIALIZATION TIMING

On the DSP56001A, the SCI and SSI clocks are stopped when the peripherals are not enabled in order to save power. As a result, the initialization time of the SCI and SSI is longer on the DSP56001A than on the DSP56001.

CONTROL REGISTERS

The OMR and the Status Register on the DSP56001A have been altered from those on the DSP56001. Refer to **Table 4-2** for details of these alterations.

Table 4-2 Summary of Control Register Differences

REGISTER	BIT	DSP56001 DEFINITION	DSP56001A DEFINITION	EXPLANATION OF DIFFERENCE
Status Register	7	Reserved— Read/Written as zero.	Reserved— Read as don't care.	On the 001A this bit may be read as 0 or 1. The user should not rely on this bit being a given value.
	14	Reserved— Read/Written as zero.	Reserved— Write as zero only, read as don't care.	If this bit is set on the 56001A, the operations performed by the Data ALU change, and 56001 code will yield erroneous results. Write this bit only as zero.
Operating Mode Register	3	Reserved— Read/.Written as zero	Reserved— Write as zero only, read as don't care.	If this bit is set, memory reads may be from incorrect locations. Write this bit only as zero.
Port B Control Register	1	Reserved— Written as zero.	Reserved— Written as zero.	Writing this bit as a 1 will result in behavior differences between the 001 and the 001A.

HOST COMMAND VECTOR REGISTER

The DSP56001A's Host Command Vector Register (CVR) also differs from that of the DSP56001 (see **Table 4-3**).

Table 4-3 Summary of Host Command Vector Register Differences

REGISTER	BIT	DSP56001 DEFINITION	DSP56001A DEFINITION	EXPLANATION OF DIFFERENCE
Host Command Vector Register (CVR)	5	Reserved— Read as zero.	Reserved—Read as don't care.	This bit should be written with only a zero on the 56001A.

HEAT DISSIPATION

The average chip junction temperature, T_J , in °C, can be obtained from:

$$\text{Equation 1: } T_J = T_A + (P_D \times \Theta_{JA})$$

Where:

T_A = ambient temperature, °C

Θ_{JA} = package thermal resistance, junction-to-ambient, °C/W

P_D = $P_{INT} + P_{I/O}$

P_{INT} = $I_{CC} \times V_{CC}$ watt—chip internal power

$P_{I/O}$ = power dissipation on input and output pins—user determined

For most applications $P_{I/O} < P_{INT}$ and $P_{I/O}$ can be neglected. An appropriate relationship between P_D and T_J (if $P_{I/O}$ is neglected) is:

$$\text{Equation 2: } P_D = K / (T_J + 273)$$

Solving equations (1) and (2) for K gives:

$$\text{Equation 3: } K = P_D \times (T_A + 273) + P_D \times \Theta_{JA}$$

Where: K is a constant pertaining to the particular package

K can be determined from equation (2) by measuring P_D (at equilibrium) for a known T_A . Using this value of K, the values of P_D and T_J can be obtained by solving equations (1) and (2) iteratively for any value of T_A . The total thermal resistance of a package (Θ_{JA}) can be separated into two components, Θ_{JC} and Θ_{CA} , representing the barrier to heat flow from the semiconductor junction to the package (case) surface (Θ_{JC}) and from the case to the outside ambient (Θ_{CA}). These terms are related by the equation:

$$\text{Equation 4: } \Theta_{JA} = \Theta_{JC} + \Theta_{CA}$$

Θ_{JC} is device-related and cannot be influenced by the user. However, Θ_{CA} is user-dependent and can be minimized by thermal management techniques such as heat sinks, ambient air cooling, and thermal convection. Thus, good thermal management can significantly reduce Θ_{CA} so that Θ_{JA} approximately equals Θ_{JC} . Values for thermal resistance presented in this document, unless estimated, were derived using the procedure described in Motorola Reliability Report 7843, "Thermal Resistance Measurement Method for MC68XX Microcomponent Devices", and are provided for design purposes only. Thermal measurements are complex and dependent on procedure and setup. User-derived values for thermal resistance may differ.

ELECTRICAL DESIGN CONSIDERATIONS**CAUTION**

This device contains protective circuitry to guard against damage due to high static voltage or electrical fields. However, normal precautions are advised to avoid application of any voltages higher than maximum rated voltages to this high-impedance circuit. Reliability of operation is enhanced if unused inputs are tied to an appropriate logic voltage level (e.g., either GND or V_{CC}).

Use the following list of recommendations to assure correct DSP operation:

- Provide a low-impedance path from the board power supply to each V_{CC} pin on the DSP, and from the board ground to each GND pin.
- Use at least four 0.1 μ F bypass capacitors positioned as close as possible to the four sides of the package to connect the V_{CC} power source to GND.
- Ensure that capacitor leads and associated printed circuit traces that connect to the chip V_{CC} and GND pins are less than 0.5 inch per capacitor lead.
- Use at least a four-layer Printed Circuit Board (PCB) with two inner layers for V_{CC} and GND.
- Because the DSP output signals have fast rise and fall times, PCB trace lengths should be minimal. This recommendation particularly applies to the address and data buses as well as the \overline{RD} , \overline{WR} , \overline{IRQA} , \overline{IRQB} , \overline{NMI} , \overline{HEN} , and \overline{HACK} pins.
- Consider all device loads, as well as parasitic capacitance due to PCB traces, when calculating capacitance. This is especially critical in systems with higher capacitive loads that could create higher transient currents in the V_{CC} and GND circuits.
- All inputs must be terminated (i.e., not allowed to float) using CMOS levels.

POWER CONSUMPTION

Power dissipation is a key issue in portable DSP applications. The following describes some factors that affect current consumption. Current consumption is described by the formula:

$$\text{Equation 5: } I = C \times V \times f$$

where :

- C = node/pin capacitance
- V = voltage swing
- f = frequency of node/pin toggle

For example, for an address pin loaded with a 50 pF capacitance and operating at 5.5V with a 33 MHz clock, toggling at its maximum possible rate (which is 8.25 MHz), the current consumption is:

$$\text{Equation 6: } I = 50 \times 10^{-12} \times 5.5 \times 8.25 \times 10^6 = 227 \text{ mA}$$

The maximum internal current value ($I_{CCI} - \text{max}$), reflects the maximum possible switching of the internal buses, which is not necessarily a real application case. The typical internal current value ($I_{CCI} - \text{typ}$) reflects the average switching of the internal buses.

The following steps are recommended for applications requiring very low current consumption:

1. Minimize external memory accesses; use internal memory accesses instead.
2. Minimize the number of pins that are switching.
3. Minimize the capacitive load on the pins.
4. Connect the unused inputs to pull-up or pull-down resistors.

HOST PORT CONSIDERATIONS

Careful synchronization is required when reading multi-bit registers that are written by another asynchronous system. This is a common problem when two asynchronous systems are connected. The situation exists in the Host Interface. The following paragraphs present considerations for proper operation.

Host Programming Considerations

UNSYNCHRONIZED READING OF RECEIVE BYTE REGISTERS

When reading receive byte registers, RXH or RXL, the host program should use interrupts or poll the RXDF flag, which indicates that data is available. This assures that the data in the receive byte registers will be stable.

OVERWRITING TRANSMIT BYTE REGISTERS

The host program should not write to the transmit byte registers, TXH or TXL, unless the TXDE bit is set, indicating that the transmit byte registers are empty. This guarantees that the transmit byte registers will transfer valid data to the HRX register.

SYNCHRONIZATION OF STATUS BITS FROM DSP TO HOST

HC, HREQ, DMA, HF3, HF2, TRDY, TXDE, and RXDF status bits are set or cleared from inside the DSP and read by the host processor (refer to the *User's Manual* for descriptions of these status bits). The host can read these status bits very quickly without regard to the clock rate used by the DSP, but the state of the bit could be changing during the read operation. Generally, this is not a system problem, since the bit will be read correctly in the next pass of any host polling routine. However, if the host asserts $\overline{\text{HEN}}$ for more than timing number 31, with a minimum cycle time of timing number 31 + 32, then these status bits are guaranteed to be stable. Exercise care when reading status bits HF3 and HF2 as an encoded pair. If the DSP changes HF3 and HF2 from 00 to 11, there is a small probability that the host could read the bits during the transition and receive 01 or 10 instead of 11. If the combination of HF3 and HF2 has significance, the host could read the wrong combination. Therefore, read the bits twice and check for consensus.

OVERWRITING THE HOST VECTOR

The host program should change the Host Vector register only when the Host Command bit (HC) is clear. This change will guarantee that the DSP interrupt control logic will receive a stable vector.

CANCELLING A PENDING HOST COMMAND EXCEPTION

The host processor may elect to clear the HC bit to cancel the host command exception request at any time before it is recognized by the DSP. Because the host does not know exactly when the exception will be recognized (due to exception processing synchronization and pipeline delays), the DSP may execute the host command exception after the HC bit is cleared. For these reasons, the HV bits must not be changed at the same time that the HC bit is cleared.

VARIANCE IN THE HOST INTERFACE TIMING

The Host Interface (HI) may vary. Therefore, a host which attempts to load (bootstrap) the DSP should first make sure that the part has completed its HI port programming (e.g., by setting the INIT bit in ICR then polling it and waiting it to be cleared, then reading the ISR or by writing the TREQ/RREQ together with the INIT and then polling INIT, ISR, and the $\overline{\text{HREQ}}$ pin).

DSP Programming Considerations

SYNCHRONIZATION OF STATUS BITS FROM HOST TO DSP

DMA, HF1, HF0, and HCP, HTDE, and HRDF status bits are set or cleared by the host processor side of the interface. These bits are individually synchronized to the DSP clock. (Refer to the *User's Manual* for descriptions of these status bits.)

READING HF0 AND HF1 AS AN ENCODED PAIR

Care must be exercised when reading status bits HF0 and HF1 as an encoded pair, because the four combinations (00, 01, 10, and 11) each have significance. A very small probability exists that the DSP will read the status bits during transition. Therefore, HF0 and HF1 should be read twice and checked for consensus.

APPLICATION EXAMPLES

The lowest cost DSP56001A-based system is shown in **Figure 4-1**. It uses no run time external memory and requires only two chips, the DSP56001A and a low cost EPROM. The EPROM read access time should be less than 780 nanoseconds when the DSP56001A is operating at a clock rate of 20.5 MHz.

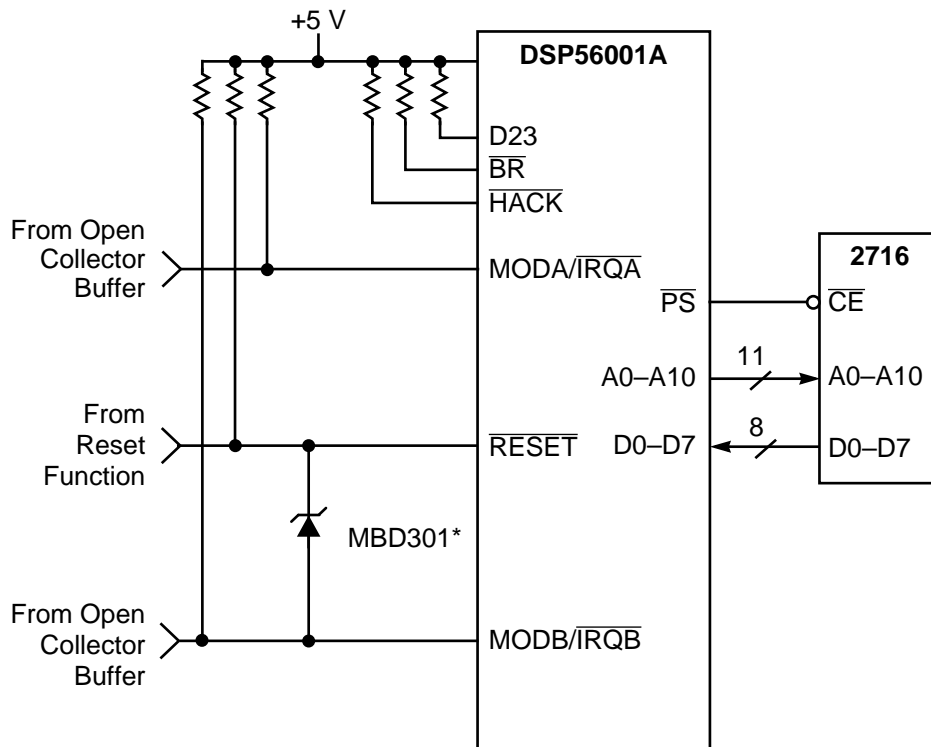

- Note:
1. *These diodes **must** be Schottky diodes.
 2. All resistors are 15 KΩ unless noted otherwise.
 3. When in Reset, \overline{IRQA} and \overline{IRQB} must be deasserted by external peripherals.

AA0904

Figure 4-1 No Glue Logic, Low Cost Memory Port Bootstrap—Mode 1

A system with external data RAM memory requires no glue logic to select the external EPROM from Bootstrap mode. \overline{PS} is used to enable the EPROM and \overline{DS} is used to enable the high speed data memories, as shown in Figure 4-2.

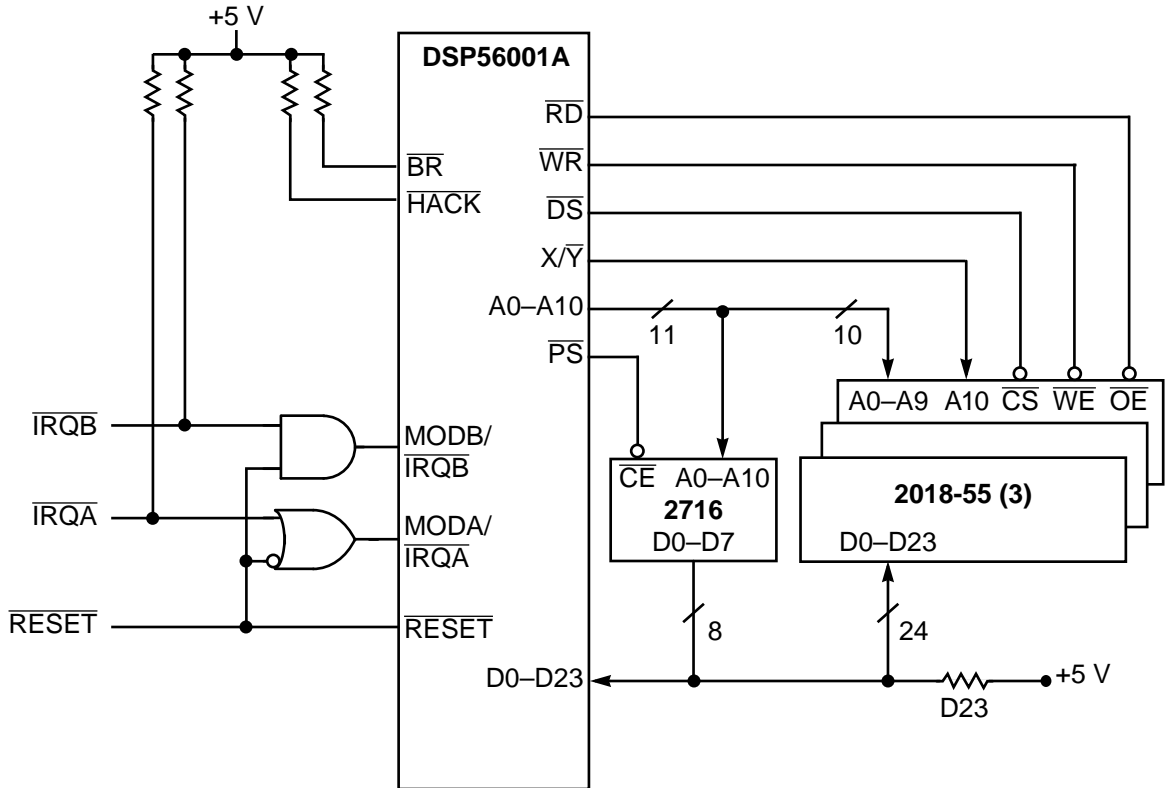

- Note: 1. All resistors are 15 K Ω unless noted otherwise.
 2. When in Reset, \overline{IRQA} and \overline{IRQB} must be deasserted by external peripherals.

AA0905

Figure 4-2 Port A Bootstrap with External Data RAM—Mode 1

Figure 4-3 shows the DSP56001A bootstrapping via the Host Port from an MC68000.

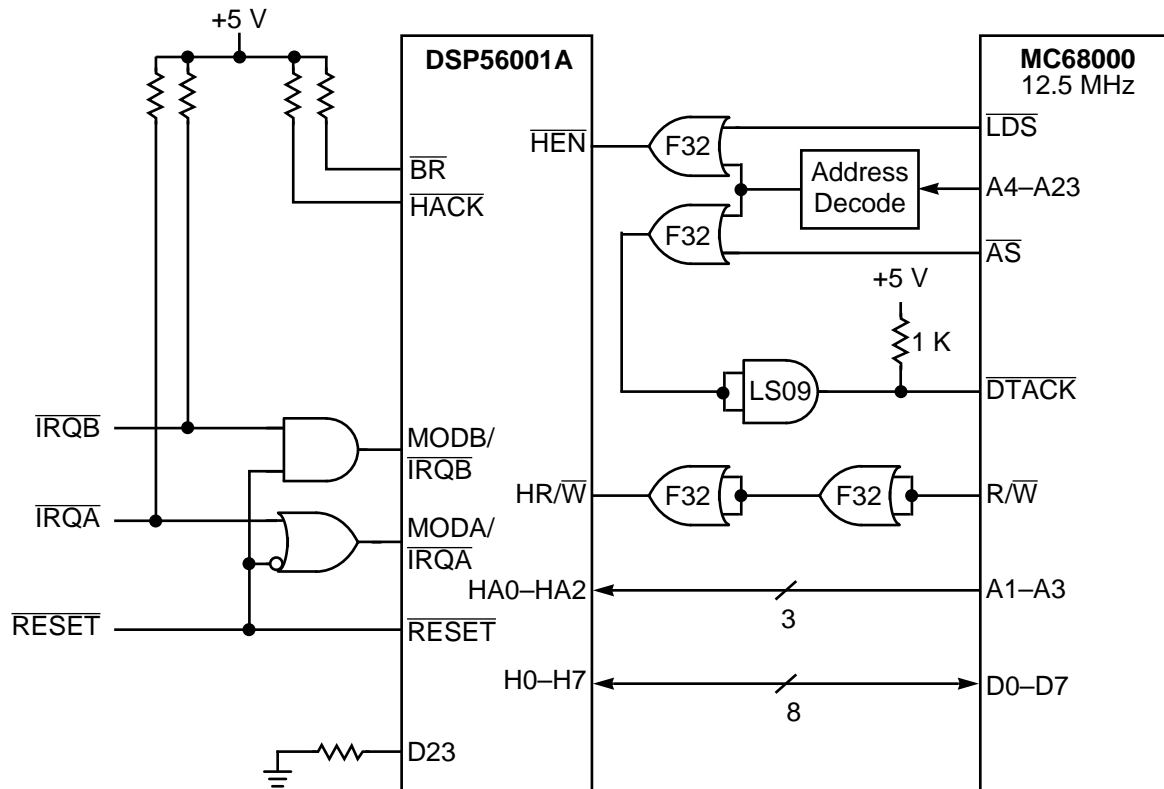

- Note: 1. All resistors are 15 K Ω unless noted otherwise.
 2. When in Reset, \overline{IRQA} and \overline{IRQB} must be deasserted by external peripherals.

AA0906

Figure 4-3 DSP56001A Host Bootstrap Example—Mode 5

In **Figure 4-4**, the DSP56001A is operated in Mode 3 with external program memory and the reset vector at location \$0000. The programmer can overlay the high-speed on-chip Program RAM with DSP algorithms by using the MOVEM instruction.

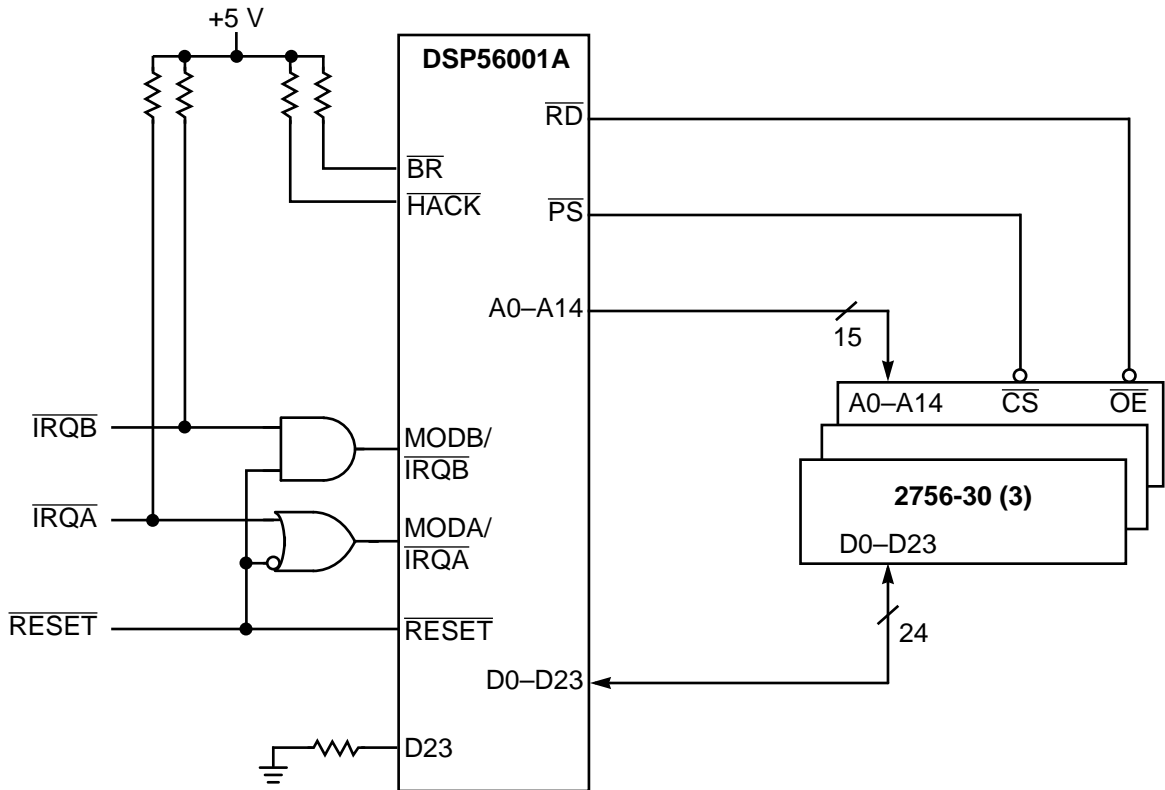

- Note:
1. All resistors are 15 K Ω unless noted otherwise.
 2. When in Reset, \overline{IRQA} and \overline{IRQB} must be deasserted by external peripherals.

AA0907

Figure 4-4 32K Words of External Program ROM—Mode 3

Figure 4-5 shows a circuit that waits until V_{CC} on the DSP56001A is at least 4.5 V before initiating a $75,000 \times T_C$ oscillator stabilization delay required for the on-chip oscillator (only $25 \times T_C$ is required for an external oscillator). This insures that the DSP is operational and stable before releasing the reset signal.

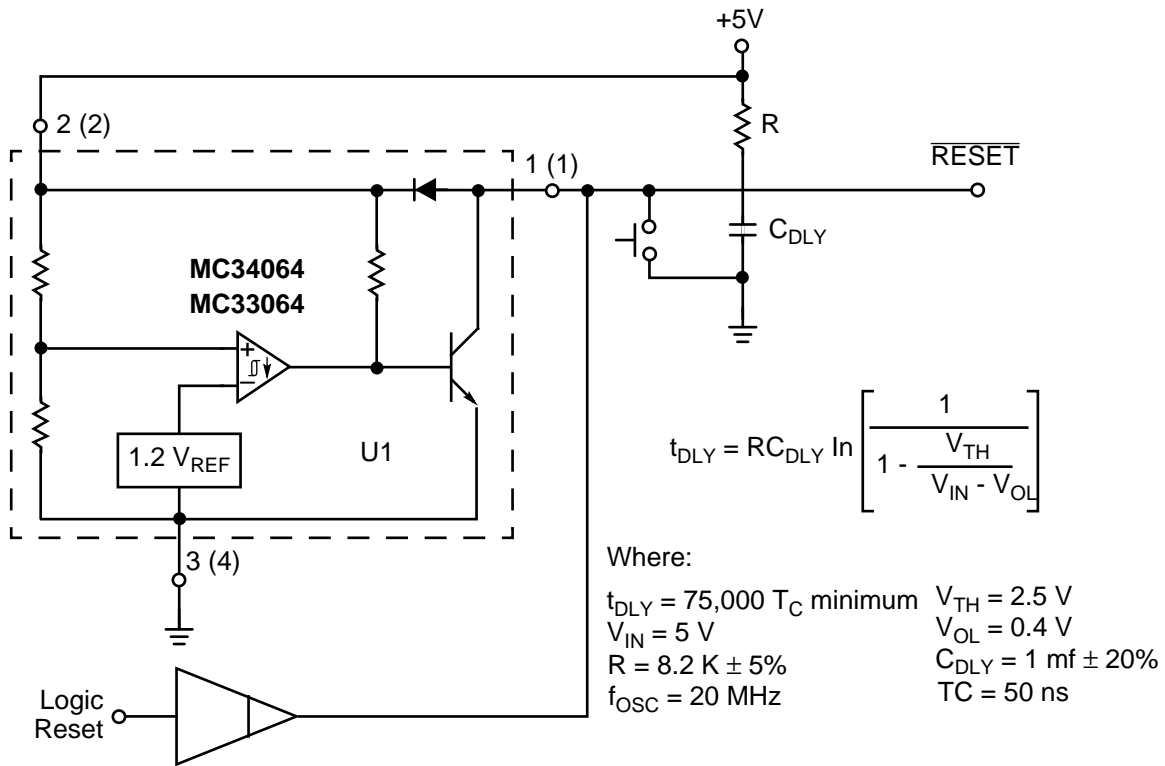

- Note:
1. \overline{IRQA} , and \overline{IRQB} must be driven to the logic levels appropriate for the application.
 2. MODA and MODB must be driven to the logic levels appropriate for the application.

AA0908

Figure 4-5 Reset Circuit Using MC34064/MC33064

Figure 4-6 shows the DSP56001A connected to the bus of an IBM-PC computer. This circuit is complete and does not require external ROM or RAM to load and execute code from the PC. The PAL equations and other details of this circuit are available in the application report entitled "DSP56001 Interface Techniques and Examples" (APR11/D).

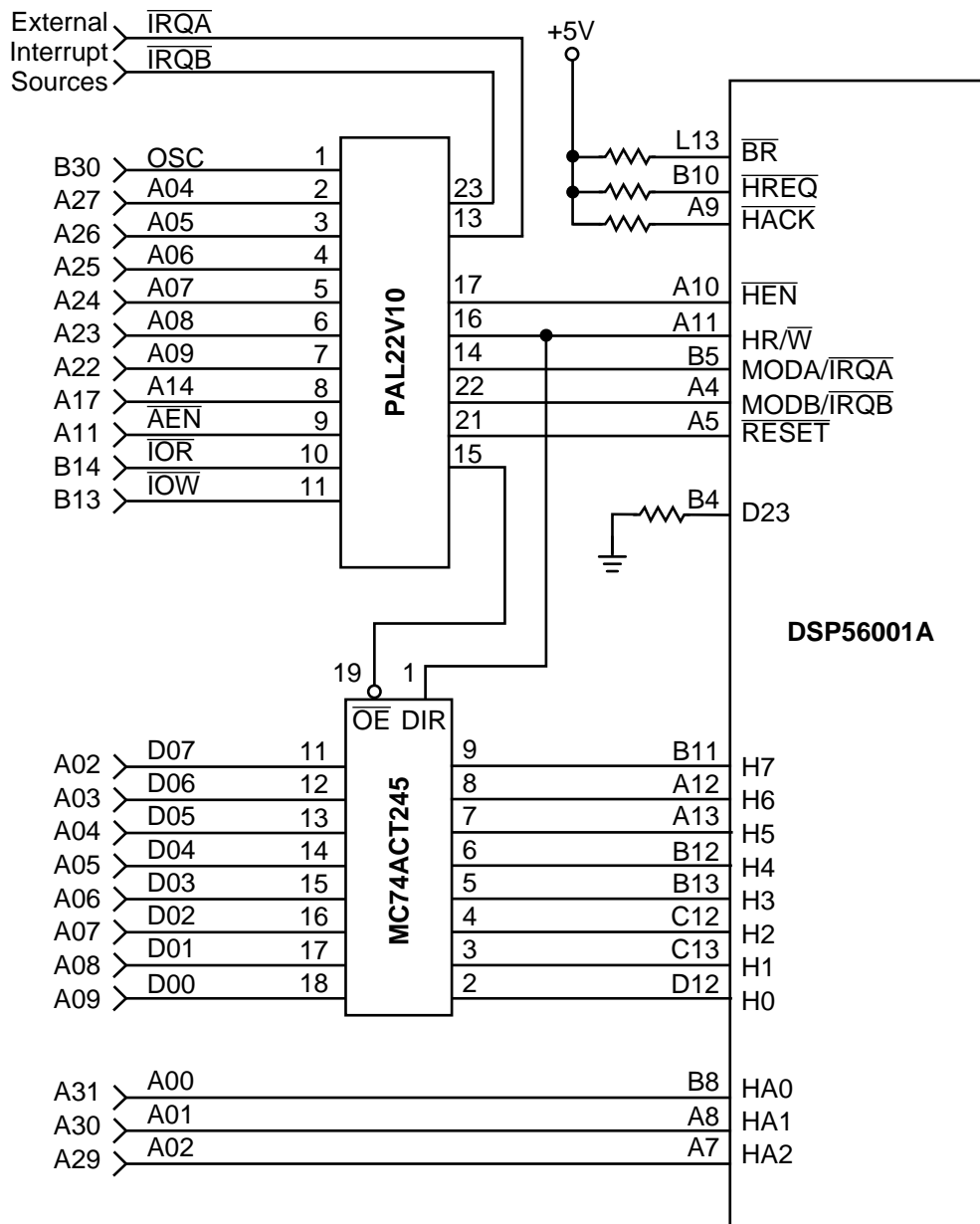

- Note: 1. Connector is J1 of ISA Bus.
 2. All series resistors are 15 KΩ.

AA0909

Figure 4-6 DSP56001A-to-ISA Bus Interface Schematic

SECTION 5

ORDERING INFORMATION

Table 5-1 lists the pertinent information needed to place an order. Consult a Motorola Semiconductor sales office or authorized distributor to determine availability and to order parts.

Table 5-1 DSP56001A Ordering Information

Part	Package Type	Pin Count	Frequency (MHz)	Order Number
DSP56001A	Ceramic Pin-Grid Array (PGA)	88	27	DSP56001ARC27
			33	DSP56001ARC33
	Plastic Quad Flat Pack (PQFP)	132	27	DSP56001AFC27
			33	DSP56001AFC33
	Ceramic Quad Flat Pack (CQFP)	132	27	DSP56001AFE27
			33	DSP56001AFE33



APPENDIX A

ROM TABLE LISTINGS

The data ROM in the 56001A contains numeric tables.

Table A-1 contains the μ -law and A-law expansion table, stored in X-ROM from address X:\$100.

Table A-2 contains the sine wave table, stored in Y-ROM from address Y:\$100.

MU-LAW / A-LAW EXPANSION TABLES

Table A-1 μ -Law / A-law Expansion Table

	ORG	X:\$100		M_16	DC	\$327C00	; 3231
				M_17	DC	\$307C00	; 3103
				M_18	DC	\$2E7C00	; 2975
M_00	DC	\$7D7C00	; 8031	M_19	DC	\$2C7C00	; 2847
M_01	DC	\$797C00	; 7775	M_1A	DC	\$2A7C00	; 2719
M_02	DC	\$757C00	; 7519	M_1B	DC	\$287C00	; 2591
M_03	DC	\$717C00	; 7263	M_1C	DC	\$267C00	; 2463
M_04	DC	\$6D7C00	; 7007	M_1D	DC	\$247C00	; 2335
M_05	DC	\$697C00	; 6751	M_1E	DC	\$227C00	; 2207
M_06	DC	\$657C00	; 6495	M_1F	DC	\$207C00	; 2079
M_07	DC	\$617C00	; 6239	M_20	DC	\$1EFC00	; 1983
M_08	DC	\$5D7C00	; 5983	M_21	DC	\$1DFC00	; 1919
M_09	DC	\$597C00	; 5727	M_22	DC	\$1CFC00	; 1855
M_0A	DC	\$557C00	; 5471	M_23	DC	\$1BFC00	; 1791
M_0B	DC	\$517C00	; 5215	M_24	DC	\$1AFC00	; 1727
M_0C	DC	\$4D7C00	; 4959	M_25	DC	\$19FC00	; 1663
M_0D	DC	\$497C00	; 4703	M_26	DC	\$18FC00	; 1599
M_0E	DC	\$457C00	; 4447	M_27	DC	\$17FC00	; 1535
M_0F	DC	\$417C00	; 4191	M_28	DC	\$16FC00	; 1471
M_10	DC	\$3E7C00	; 3999	M_29	DC	\$15FC00	; 1407
M_11	DC	\$3C7C00	; 3871	M_2A	DC	\$14FC00	; 1343
M_12	DC	\$3A7C00	; 3743	M_2B	DC	\$13FC00	; 1279
M_13	DC	\$387C00	; 3615	M_2C	DC	\$12FC00	; 1215
M_14	DC	\$367C00	; 3487	M_2D	DC	\$11FC00	; 1151
M_15	DC	\$347C00	; 3359				

Freescale Semiconductor, Inc.

ROM Table Listings

mu-Law / A-Law Expansion Tables

M_2E	DC	\$10FC00	; 1087	M_57	DC	\$028C00	; 163
M_2F	DC	\$0FFC00	; 1023	M_58	DC	\$026C00	; 155
M_30	DC	\$0F3C00	; 975	M_59	DC	\$024C00	; 147
M_31	DC	\$0EBC00	; 943	M_5A	DC	\$022C00	; 139
M_32	DC	\$0E3C00	; 911	M_5B	DC	\$020C00	; 131
M_33	DC	\$0DBC00	; 879	M_5C	DC	\$01EC00	; 123
M_34	DC	\$0D3C00	; 847	M_5D	DC	\$01CC00	; 115
M_35	DC	\$0CBC00	; 815	M_5E	DC	\$01AC00	; 107
M_36	DC	\$0C3C00	; 783	M_5F	DC	\$018C00	; 99
M_37	DC	\$0BBC00	; 751	M_60	DC	\$017400	; 93
M_38	DC	\$0B3C00	; 719	M_61	DC	\$016400	; 89
M_39	DC	\$0ABC00	; 687	M_62	DC	\$015400	; 85
M_3A	DC	\$0A3C00	; 655	M_63	DC	\$014400	; 81
M_3B	DC	\$09BC00	; 623	M_64	DC	\$013400	; 77
M_3C	DC	\$093C00	; 591	M_65	DC	\$012400	; 73
M_3D	DC	\$08BC00	; 559	M_66	DC	\$011400	; 69
M_3E	DC	\$083C00	; 527	M_67	DC	\$010400	; 65
M_3F	DC	\$07BC00	; 495	M_68	DC	\$00F400	; 61
M_40	DC	\$075C00	; 471	M_69	DC	\$00E400	; 57
M_41	DC	\$071C00	; 455	M_6A	DC	\$00D400	; 53
M_42	DC	\$06DC00	; 439	M_6B	DC	\$00C400	; 49
M_43	DC	\$069C00	; 423	M_6C	DC	\$00B400	; 45
M_44	DC	\$065C00	; 407	M_6D	DC	\$00A400	; 41
M_45	DC	\$061C00	; 391	M_6E	DC	\$009400	; 37
M_46	DC	\$05DC00	; 375	M_6F	DC	\$008400	; 33
M_47	DC	\$059C00	; 359	M_70	DC	\$007800	; 30
M_48	DC	\$055C00	; 343	M_71	DC	\$007000	; 28
M_49	DC	\$051C00	; 327	M_72	DC	\$006800	; 26
M_4A	DC	\$04DC00	; 311	M_73	DC	\$006000	; 24
M_4B	DC	\$049C00	; 295	M_74	DC	\$005800	; 22
M_4C	DC	\$045C00	; 279	M_75	DC	\$005000	; 20
M_4D	DC	\$041C00	; 263	M_76	DC	\$004800	; 18
M_4E	DC	\$03DC00	; 247	M_77	DC	\$004000	; 16
M_4F	DC	\$039C00	; 231	M_78	DC	\$003800	; 14
M_50	DC	\$036C00	; 219	M_79	DC	\$003000	; 12
M_51	DC	\$034C00	; 211	M_7A	DC	\$002800	; 10
M_52	DC	\$032C00	; 203	M_7B	DC	\$002000	; 8
M_53	DC	\$030C00	; 195	M_7C	DC	\$001800	; 6
M_54	DC	\$02EC00	; 187	M_7D	DC	\$001000	; 4
M_55	DC	\$02CC00	; 179	M_7E	DC	\$000800	; 2
M_56	DC	\$02AC00	; 171	M_7F	DC	\$000000	; 0

A_80	DC	\$158000	;	688	A_A9	DC	\$720000	;	3648
A_81	DC	\$148000	;	656	A_AA	DC	\$7E0000	;	4032
A_82	DC	\$178000	;	752	A_AB	DC	\$7A0000	;	3904
A_83	DC	\$168000	;	720	A_AC	DC	\$660000	;	3264
A_84	DC	\$118000	;	560	A_AD	DC	\$620000	;	3136
A_85	DC	\$108000	;	528	A_AE	DC	\$6E0000	;	3520
A_86	DC	\$138000	;	624	A_AF	DC	\$6A0000	;	3392
A_87	DC	\$128000	;	592	A_B0	DC	\$2B0000	;	1376
A_88	DC	\$1D8000	;	944	A_B1	DC	\$290000	;	1312
A_89	DC	\$1C8000	;	912	A_B2	DC	\$2F0000	;	1504
A_8A	DC	\$1F8000	;	1008	A_B3	DC	\$2D0000	;	1440
A_8B	DC	\$1E8000	;	976	A_B4	DC	\$230000	;	1120
A_8C	DC	\$198000	;	816	A_B5	DC	\$210000	;	1056
A_8D	DC	\$188000	;	784	A_B6	DC	\$270000	;	1248
A_8E	DC	\$1B8000	;	880	A_B7	DC	\$250000	;	1184
A_8F	DC	\$1A8000	;	848	A_B8	DC	\$3B0000	;	1888
A_90	DC	\$0AC000	;	344	A_B9	DC	\$390000	;	1824
A_91	DC	\$0A4000	;	328	A_BA	DC	\$3F0000	;	2016
A_92	DC	\$0BC000	;	376	A_BB	DC	\$3D0000	;	1952
A_93	DC	\$0B4000	;	360	A_BC	DC	\$330000	;	1632
A_94	DC	\$08C000	;	280	A_BD	DC	\$310000	;	1568
A_95	DC	\$084000	;	264	A_BE	DC	\$370000	;	1760
A_96	DC	\$09C000	;	312	A_BF	DC	\$350000	;	1696
A_97	DC	\$094000	;	296	A_C0	DC	\$015800	;	43
A_98	DC	\$0EC000	;	472	A_C1	DC	\$014800	;	41
A_99	DC	\$0E4000	;	456	A_C2	DC	\$017800	;	47
A_9A	DC	\$0FC000	;	504	A_C3	DC	\$016800	;	45
A_9B	DC	\$0F4000	;	488	A_C4	DC	\$011800	;	35
A_9C	DC	\$0CC000	;	408	A_C5	DC	\$010800	;	33
A_9D	DC	\$0C4000	;	392	A_C6	DC	\$013800	;	39
A_9E	DC	\$0DC000	;	440	A_C7	DC	\$012800	;	37
A_9F	DC	\$0D4000	;	424	A_C8	DC	\$01D800	;	59
A_A0	DC	\$560000	;	2752	A_C9	DC	\$01C800	;	57
A_A1	DC	\$520000	;	2624	A_CA	DC	\$01F800	;	63
A_A2	DC	\$5E0000	;	3008	A_CB	DC	\$01E800	;	61
A_A3	DC	\$5A0000	;	2880	A_CC	DC	\$019800	;	51
A_A4	DC	\$460000	;	2240	A_CD	DC	\$018800	;	49
A_A5	DC	\$420000	;	2112	A_CE	DC	\$01B800	;	55
A_A6	DC	\$4E0000	;	2496	A_CF	DC	\$01A800	;	53
A_A7	DC	\$4A0000	;	2368	A_D0	DC	\$005800	;	11
A_A8	DC	\$760000	;	3776	A_D1	DC	\$004800	;	9

Freescale Semiconductor, Inc.

ROM Table Listings

mu-Law / A-Law Expansion Tables

A_D2	DC	\$007800	;	15	A_FB	DC	\$03D000	;	122
A_D3	DC	\$006800	;	13	A_FC	DC	\$033000	;	102
A_D4	DC	\$001800	;	3	A_FD	DC	\$031000	;	98
A_D5	DC	\$000800	;	1	A_FE	DC	\$037000	;	110
A_D6	DC	\$003800	;	7	A_FF	DC	\$035000	;	106
A_D7	DC	\$002800	;	5					
A_D8	DC	\$00D800	;	27					
A_D9	DC	\$00C800	;	25					
A_DA	DC	\$00F800	;	31					
A_DB	DC	\$00E800	;	29					
A_DC	DC	\$009800	;	19					
A_DD	DC	\$008800	;	17					
A_DE	DC	\$00B800	;	23					
A_DF	DC	\$00A800	;	21					
A_E0	DC	\$056000	;	172					
A_E1	DC	\$052000	;	164					
A_E2	DC	\$05E000	;	188					
A_E3	DC	\$05A000	;	180					
A_E4	DC	\$046000	;	140					
A_E5	DC	\$042000	;	132					
A_E6	DC	\$04E000	;	156					
A_E7	DC	\$04A000	;	148					
A_E8	DC	\$076000	;	236					
A_E9	DC	\$072000	;	228					
A_EA	DC	\$07E000	;	252					
A_EB	DC	\$07A000	;	244					
A_EC	DC	\$066000	;	204					
A_ED	DC	\$062000	;	196					
A_EE	DC	\$06E000	;	220					
A_EF	DC	\$06A000	;	212					
A_F0	DC	\$02B000	;	86					
A_F1	DC	\$029000	;	82					
A_F2	DC	\$02F000	;	94					
A_F3	DC	\$02D000	;	90					
A_F4	DC	\$023000	;	70					
A_F5	DC	\$021000	;	66					
A_F6	DC	\$027000	;	78					
A_F7	DC	\$025000	;	74					
A_F8	DC	\$03B000	;	118					
A_F9	DC	\$039000	;	114					
A_FA	DC	\$03F000	;	126					

SINE WAVE TABLE

This sine wave table is normally used by FFT routines that use bit-reversed address pointers. This table can be used as it is for up to 512 point FFTs; however, for larger FFTs, the table must be copied to a different memory location to allow the Reverse-carry addressing mode to be used (see REVERSE-CARRY MODIFIER (Mn = \$0000) in the *DSP56001 User's Manual* for additional information).

Table A-2 Sine Wave Table

ORG	Y:\$100	S_1A DC	\$4C3FE0	; +0.5956993103
;		S_1B DC	\$4EBFE9	; +0.6152315736
S_00 DC	\$000000	S_1C DC	\$5133CD	; +0.6343932748
S_01 DC	\$03242B	S_1D DC	\$539B2B	; +0.6531729102
S_02 DC	\$0647D9	S_1E DC	\$55F5A5	; +0.6715589762
S_03 DC	\$096A90	S_1F DC	\$5842DD	; +0.6895405054
S_04 DC	\$0C8BD3	S_20 DC	\$5A827A	; +0.7071068287
S_05 DC	\$0FAB27	S_21 DC	\$5CB421	; +0.7242470980
S_06 DC	\$12C810	S_22 DC	\$5ED77D	; +0.7409511805
S_07 DC	\$15E214	S_23 DC	\$60EC38	; +0.7572088242
S_08 DC	\$18F8B8	S_24 DC	\$62F202	; +0.7730104923
S_09 DC	\$1C0B82	S_25 DC	\$64E889	; +0.7883464098
S_0A DC	\$1F19F9	S_26 DC	\$66CF81	; +0.8032075167
S_0B DC	\$2223A5	S_27 DC	\$68A69F	; +0.8175848722
S_0C DC	\$25280C	S_28 DC	\$6A6D99	; +0.8314697146
S_0D DC	\$2826B9	S_29 DC	\$6C2429	; +0.8448535204
S_0E DC	\$2B1F35	S_2A DC	\$6DCA0D	; +0.8577286005
S_0F DC	\$2E110A	S_2B DC	\$6F5F03	; +0.8700870275
S_10 DC	\$30FBC5	S_2C DC	\$70E2CC	; +0.8819212914
S_11 DC	\$33DEF3	S_2D DC	\$72552D	; +0.8932244182
S_12 DC	\$36BA20	S_2E DC	\$73B5EC	; +0.9039893150
S_13 DC	\$398CDD	S_2F DC	\$7504D3	; +0.9142097235
S_14 DC	\$3C56BA	S_30 DC	\$7641AF	; +0.9238795042
S_15 DC	\$3F174A	S_31 DC	\$776C4F	; +0.9329928160
S_16 DC	\$41CE1E	S_32 DC	\$788484	; +0.9415441155
S_17 DC	\$447ACD	S_33 DC	\$798A24	; +0.9495282173
S_18 DC	\$471CED	S_34 DC	\$7A7D05	; +0.9569402933
S_19 DC	\$49B415	S_35 DC	\$7B5D04	; +0.9637761116

Freescale Semiconductor, Inc.

ROM Table Listings

Sine Wave Table

S_36 DC	\$7C29FC	; +0.9700313210	S_5F DC	\$5CB421	; +0.7242470980
S_37 DC	\$7CE3CF	; +0.9757022262	S_60 DC	\$5A827A	; +0.7071068287
S_38 DC	\$7D8A5F	; +0.9807853103	S_61 DC	\$5842DD	; +0.6895405054
S_39 DC	\$7E1D94	; +0.9852777123	S_62 DC	\$55F5A5	; +0.6715589762
S_3A DC	\$7E9D56	; +0.9891765118	S_63 DC	\$539B2B	; +0.6531729102
S_3B DC	\$7F0992	; +0.9924796224	S_64 DC	\$5133CD	; +0.6343932748
S_3C DC	\$7F6237	; +0.9951847792	S_65 DC	\$4EBFE9	; +0.6152315736
S_3D DC	\$7FA737	; +0.9972904921	S_66 DC	\$4C3FE0	; +0.5956993103
S_3E DC	\$7FD888	; +0.9987955093	S_67 DC	\$49B415	; +0.5758082271
S_3F DC	\$7FF622	; +0.9996988773	S_68 DC	\$471CED	; +0.5555701852
S_40 DC	\$7FFFFFF	; +0.9999998808	S_69 DC	\$447ACD	; +0.5349975824
S_41 DC	\$7FF622	; +0.9996988773	S_6A DC	\$41CE1E	; +0.5141026974
S_42 DC	\$7FD888	; +0.9987955093	S_6B DC	\$3F174A	; +0.4928981960
S_43 DC	\$7FA737	; +0.9972904921	S_6C DC	\$3C56BA	; +0.4713967144
S_44 DC	\$7F6237	; +0.9951847792	S_6D DC	\$398CDD	; +0.4496113062
S_45 DC	\$7F0992	; +0.9924796224	S_6E DC	\$36BA20	; +0.4275551140
S_46 DC	\$7E9D56	; +0.9891765118	S_6F DC	\$33DEF3	; +0.4052414000
S_47 DC	\$7E1D94	; +0.9852777123	S_70 DC	\$30FBC5	; +0.3826833963
S_48 DC	\$7D8A5F	; +0.9807853103	S_71 DC	\$2E110A	; +0.3598949909
S_49 DC	\$7CE3CF	; +0.9757022262	S_72 DC	\$2B1F35	; +0.3368898928
S_4A DC	\$7C29FC	; +0.9700313210	S_73 DC	\$2826B9	; +0.3136816919
S_4B DC	\$7B5D04	; +0.9637761116	S_74 DC	\$25280C	; +0.2902846038
S_4C DC	\$7A7D05	; +0.9569402933	S_75 DC	\$2223A5	; +0.2667128146
S_4D DC	\$798A24	; +0.9495282173	S_76 DC	\$1F19F9	; +0.2429800928
S_4E DC	\$788484	; +0.9415441155	S_77 DC	\$1C0B82	; +0.2191012055
S_4F DC	\$776C4F	; +0.9329928160	S_78 DC	\$18F8B8	; +0.1950902939
S_50 DC	\$7641AF	; +0.9238795042	S_79 DC	\$15E214	; +0.1709619015
S_51 DC	\$7504D3	; +0.9142097235	S_7A DC	\$12C810	; +0.1467303932
S_52 DC	\$73B5EC	; +0.9039893150	S_7B DC	\$0FAB27	; +0.1224106997
S_53 DC	\$72552D	; +0.8932244182	S_7C DC	\$0C8BD3	; +0.0980170965
S_54 DC	\$70E2CC	; +0.8819212914	S_7D DC	\$096A90	; +0.0735644996
S_55 DC	\$6F5F03	; +0.8700870275	S_7E DC	\$0647D9	; +0.0490676016
S_56 DC	\$6DCA0D	; +0.8577286005	S_7F DC	\$03242B	; +0.0245412998
S_57 DC	\$6C2429	; +0.8448535204	S_80 DC	\$000000	; +0.0000000000
S_58 DC	\$6A6D99	; +0.8314697146	S_81 DC	\$FCDBD5	; -0.0245412998
S_59 DC	\$68A69F	; +0.8175848722	S_82 DC	\$F9B827	; -0.0490676016
S_5A DC	\$66CF81	; +0.8032075167	S_83 DC	\$F69570	; -0.0735644996
S_5B DC	\$64E889	; +0.7883464098	S_84 DC	\$F3742D	; -0.0980170965
S_5C DC	\$62F202	; +0.7730104923	S_85 DC	\$F054D9	; -0.1224106997
S_5D DC	\$60EC38	; +0.7572088242	S_86 DC	\$ED37F0	; -0.1467303932
S_5E DC	\$5ED77D	; +0.7409511805	S_87 DC	\$EA1DEC	; -0.1709619015

S_88 DC	\$E70748	;	-0.1950902939	S_B1 DC	\$8893B1	;	-0.9329928160
S_89 DC	\$E3F47E	;	-0.2191012055	S_B2 DC	\$877B7C	;	-0.9415441155
S_8A DC	\$E0E607	;	-0.2429800928	S_B3 DC	\$8675DC	;	-0.9495282173
S_8B DC	\$DDDC5B	;	-0.2667128146	S_B4 DC	\$8582FB	;	-0.9569402933
S_8C DC	\$DAD7F4	;	-0.2902846038	S_B5 DC	\$84A2FC	;	-0.9637761116
S_8D DC	\$D7D947	;	-0.3136816919	S_B6 DC	\$83D604	;	-0.9700313210
S_8E DC	\$D4E0CB	;	-0.3368898928	S_B7 DC	\$831C31	;	-0.9757022262
S_8F DC	\$D1EEF6	;	-0.3598949909	S_B8 DC	\$8275A1	;	-0.9807853103
S_90 DC	\$CF043B	;	-0.3826833963	S_B9 DC	\$81E26C	;	-0.9852777123
S_91 DC	\$CC210D	;	-0.4052414000	S_BA DC	\$8162AA	;	-0.9891765118
S_92 DC	\$C945E0	;	-0.4275551140	S_BB DC	\$80F66E	;	-0.9924796224
S_93 DC	\$C67323	;	-0.4496113062	S_BC DC	\$809DC9	;	-0.9951847792
S_94 DC	\$C3A946	;	-0.4713967144	S_BD DC	\$8058C9	;	-0.9972904921
S_95 DC	\$C0E8B6	;	-0.4928981960	S_BE DC	\$802778	;	-0.9987955093
S_96 DC	\$BE31E2	;	-0.5141026974	S_BF DC	\$8009DE	;	-0.9996988773
S_97 DC	\$BB8533	;	-0.5349975824	S_C0 DC	\$800000	;	-1.0000000000
S_98 DC	\$B8E313	;	-0.5555701852	S_C1 DC	\$8009DE	;	-0.9996988773
S_99 DC	\$B64BEB	;	-0.5758082271	S_C2 DC	\$802778	;	-0.9987955093
S_9A DC	\$B3C020	;	-0.5956993103	S_C3 DC	\$8058C9	;	-0.9972904921
S_9B DC	\$B14017	;	-0.6152315736	S_C4 DC	\$809DC9	;	-0.9951847792
S_9C DC	\$AECC33	;	-0.6343932748	S_C5 DC	\$80F66E	;	-0.9924796224
S_9D DC	\$AC64D5	;	-0.6531729102	S_C6 DC	\$8162AA	;	-0.9891765118
S_9E DC	\$AA0A5B	;	-0.6715589762	S_C7 DC	\$81E26C	;	-0.9852777123
S_9F DC	\$A7BD23	;	-0.6895405054	S_C8 DC	\$8275A1	;	-0.9807853103
S_A0 DC	\$A57D86	;	-0.7071068287	S_C9 DC	\$831C31	;	-0.9757022262
S_A1 DC	\$A34BDF	;	-0.7242470980	S_CA DC	\$83D604	;	-0.9700313210
S_A2 DC	\$A12883	;	-0.7409511805	S_CB DC	\$84A2FC	;	-0.9637761116
S_A3 DC	\$9F13C8	;	-0.7572088242	S_CC DC	\$8582FB	;	-0.9569402933
S_A4 DC	\$9D0DFE	;	-0.7730104923	S_CD DC	\$8675DC	;	-0.9495282173
S_A5 DC	\$9B1777	;	-0.7883464098	S_CE DC	\$877B7C	;	-0.9415441155
S_A6 DC	\$99307F	;	-0.8032075167	S_CF DC	\$8893B1	;	-0.9329928160
S_A7 DC	\$975961	;	-0.8175848722	S_D0 DC	\$89BE51	;	-0.9238795042
S_A8 DC	\$959267	;	-0.8314697146	S_D1 DC	\$8AFB2D	;	-0.9142097235
S_A9 DC	\$93DBD7	;	-0.8448535204	S_D2 DC	\$8C4A14	;	-0.9039893150
S_AA DC	\$9235F3	;	-0.8577286005	S_D3 DC	\$8DAAD3	;	-0.8932244182
S_AB DC	\$90A0FD	;	-0.8700870275	S_D4 DC	\$8F1D34	;	-0.8819212914
S_AC DC	\$8F1D34	;	-0.8819212914	S_D5 DC	\$90A0FD	;	-0.8700870275
S_AD DC	\$8DAAD3	;	-0.8932244182	S_D6 DC	\$9235F3	;	-0.8577286005
S_AE DC	\$8C4A14	;	-0.9039893150	S_D7 DC	\$93DBD7	;	-0.8448535204
S_AF DC	\$8AFB2D	;	-0.9142097235	S_D8 DC	\$959267	;	-0.8314697146
S_B0 DC	\$89BE51	;	-0.9238795042	S_D9 DC	\$975961	;	-0.8175848722

ROM Table Listings

Sine Wave Table

S_DA	DC	\$99307F	;	-0.8032075167
S_DB	DC	\$9B1777	;	-0.7883464098
S_DC	DC	\$9D0DFE	;	-0.7730104923
S_DD	DC	\$9F13C8	;	-0.7572088242
S_DE	DC	\$A12883	;	-0.7409511805
S_DF	DC	\$A34BDF	;	-0.7242470980
S_E0	DC	\$A57D86	;	-0.7071068287
S_E1	DC	\$A7BD23	;	-0.6895405054
S_E2	DC	\$AA0A5B	;	-0.6715589762
S_E3	DC	\$AC64D5	;	-0.6531729102
S_E4	DC	\$AECC33	;	-0.6343932748
S_E5	DC	\$B14017	;	-0.6152315736
S_E6	DC	\$B3C020	;	-0.5956993103
S_E7	DC	\$B64BEB	;	-0.5758082271
S_E8	DC	\$B8E313	;	-0.5555701852
S_E9	DC	\$BB8533	;	-0.5349975824
S_EA	DC	\$BE31E2	;	-0.5141026974
S_EB	DC	\$C0E8B6	;	-0.4928981960
S_EC	DC	\$C3A946	;	-0.4713967144
S_ED	DC	\$C67323	;	-0.4496113062
S_EE	DC	\$C945E0	;	-0.4275551140
S_EF	DC	\$CC210D	;	-0.4052414000
S_F0	DC	\$CF043B	;	-0.3826833963
S_F1	DC	\$D1EEF6	;	-0.3598949909
S_F2	DC	\$D4E0CB	;	-0.3368898928
S_F3	DC	\$D7D947	;	-0.3136816919
S_F4	DC	\$DAD7F4	;	-0.2902846038
S_F5	DC	\$DDDC5B	;	-0.2667128146
S_F6	DC	\$E0E607	;	-0.2429800928
S_F7	DC	\$E3F47E	;	-0.2191012055
S_F8	DC	\$E70748	;	-0.1950902939
S_F9	DC	\$EA1DEC	;	-0.1709619015
S_FA	DC	\$ED37F0	;	-0.1467303932
S_FB	DC	\$F054D9	;	-0.1224106997
S_FC	DC	\$F3742D	;	-0.0980170965
S_FD	DC	\$F69570	;	-0.0735644996
S_FE	DC	\$F9B827	;	-0.0490676016
S_FF	DC	\$FCDBD5	;	-0.0245412998



Freescale Semiconductor, Inc.

Freescale Semiconductor, Inc.

Mfax is a trademark of Motorola, Inc.



Motorola reserves the right to make changes without further notice to any products herein. Motorola makes no warranty, representation or guarantee regarding the suitability of its products for any particular purpose, nor does Motorola assume any liability arising out of the application or use of any product or circuit, and specifically disclaims any and all liability, including without limitation consequential or incidental damages. "Typical" parameters which may be provided in Motorola data sheets and/or specifications can and do vary in different applications and actual performance may vary over time. All operating parameters, including "Typicals" must be validated for each customer application by customer's technical experts. Motorola does not convey any license under its patent rights nor the rights of others. Motorola products are not designed, intended, or authorized for use as components in systems intended for surgical implant into the body, or other applications intended to support life, or for any other application in which the failure of the Motorola product could create a situation where personal injury or death may occur. Should Buyer purchase or use Motorola products for any such unintended or unauthorized application, Buyer shall indemnify and hold Motorola and its officers, employees, subsidiaries, affiliates, and distributors harmless against all claims, costs, damages, and expenses, and reasonable attorney fees arising out of, directly or indirectly, any claim of personal injury or death associated with such unintended or unauthorized use, even if such claim alleges that Motorola was negligent regarding the design or manufacture of the part. Motorola and  are registered trademarks of Motorola, Inc. Motorola, Inc. is an Equal Opportunity/Affirmative Action Employer.

How to reach us:

USA/Europe/Locations Not

Listed:

Motorola Literature Distribution
P.O. Box 5405
Denver, Colorado 80217
303-675-2140
1 (800) 441-2447

Mfax™:

RMFAX0@email.sps.mot.com
TOUCHTONE (602) 244-6609
US and Canada ONLY:
1 (800) 774-1848

Asia/Pacific:

Motorola Semiconductors H.K. Ltd.
8B Tai Ping Industrial Park
51 Ting Kok Road
Tai Po, N.T., Hong Kong
852-26629298

Technical Resource Center:

1 (800) 521-6274

DSP Helpline

dsphelp@dsp.sps.mot.com

Japan:

Nippon Motorola Ltd.
SPD, Strategic Planning Office
4-32-1, Nishi-Gotanda
Shinagawa-ku, Tokyo 141, Japan
81-3-5487-8488

Internet:

<http://www.motorola-dsp.com>



MOTOROLA

**For More Information On This Product,
Go to: www.freescale.com**