

FEATURES

- **WIDE-BAND OPERATION:** DC to 890 MHz
- **DOUBLE BALANCED MIXER:**
Low Distortion
Low Oscillator Radiation
- **BALANCED AMPLIFIER FOR VOLTAGE CONTROLLED OSCILLATORS:**
Up to UHF Frequency
- **SINGLE ENDED PUSH-PULL IF AMPLIFIER:**
Constant Resistive Impedance
- **SWITCHABLE AS MIXER OR IF AMP**
- **SMALL PACKAGE:** 8 Pin SSOP

DESCRIPTION

The UPC1686GV is a silicon monolithic integrated circuit designed as a wide-band mixer/oscillator/IF amp suitable for VHF TV/CATV tuners. Device features include: 20 dB gain from 55 to 890 MHz and an output power of +10 dBm at saturation. The device is available in an 8 pin SSOP package. The nominal output impedance of the device is 75 ohms.

INTERNAL BLOCK DIAGRAM

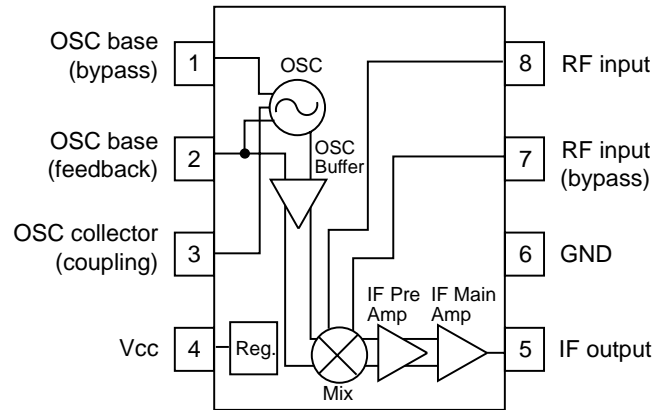

ELECTRICAL CHARACTERISTICS (TA = 25°C, VCC = 5 V)

PART NUMBER PACKAGE OUTLINE			UPC1686GV S08			TEST CIRCUIT
SYMBOLS	PARAMETERS AND CONDITIONS	UNITS	MIN	TYP	MAX	
I _{CC}	Circuit Current, no input signal	mA	25	38	48	Fig. 1
CG	Conversion Gain ¹					Fig. 1
	RF = 55 MHz, IF = 44 MHz	dB	15	19	22	
	RF = 200 MHz, IF = 50 MHz	dB	15.5	19.5	22.5	
	RF = 440 MHz, IF = 50 MHz	dB	16	20	23	
NF	Noise Figure ² at RF = 55 MHz, IF = 44 MHz	dB		11	14	Fig. 1
	RF = 200 MHz, IF = 50 MHz	dB		11	14	
	RF = 440 MHz, IF = 50 MHz	dB		12	15	
CM	1% Cross modulation ³ at IF = 50 MHz, 75 Ω Open Terminal, RF = 55 to 470 MHz	dBμ		94		Fig. 1
PSAT	Saturated Output Power ⁴	dBm		+10		Fig. 1
f _{STB}	Oscillator Frequency Stability at V _{CC} ± 10% OSC f = 100 to 490 MHz	kHz		±100		Fig. 2
f _{DRIFT}	Oscillation Frequency Drift, OSC f = 100 to 490 MHz	kHz		100		Fig. 2
V _{OSC}	Oscillation Start Voltage OSC f = 100 to 490 MHz	V		3.0		Fig. 2
V _{SWR}	IF Output			1.3	1.5	Fig. 1

Notes:

1. P_{RFIn} = -40 dBm, P_{OSC} = -5 dBm
2. P_{OSC} = -5 dBm
3. Undesired = Desired ± 12 MHz, 30% 100 kHz AM S/I Ratio = 46 dB
4. P_{RFIn} = 0 dBm, P_{OSC} = -5 dBm

ABSOLUTE MAXIMUM RATINGS¹ (T_A = 25°C)

SYMBOLS	PARAMETERS	UNITS	RATINGS
V _{CC}	Supply Voltage	V	6
P _T	Total Power Dissipation ²	mW	250
T _{OP}	Operating Temperature	°C	-40 to +85
T _{STG}	Storage Temperature	°C	-65 to +150

Notes:

1. Operation in excess of any one of these parameters may result in permanent damage.
2. T_A = 85°C mounted on 50 x 50 x 1.6 (mm) PWB (glass-epoxy).

PIN DESCRIPTION

PIN NO.	SYMBOL	FUNCTION AND APPLICATION	EQUIVALENT CIRCUIT
1	OSC Base (Bypass)	<p>Internal oscillator consists of a balanced amplifier. Pins 2 and 3 should be externally equipped with a tank resonator circuit in order to oscillate with feedback loop.</p> <p>Pin 1 should be grounded through a coupling capacitor (~10 pF).</p> <p>Pin 3 is an open collector. This pin should be coupled through resistor or choke coil in order to adjust Q and connect to supply voltage. In case of unstable oscillation, lowering the Q will help to stabilize the operation.</p>	
2	OSC Base (Feedback)		
3	OSC Collector (Coupling)		
4	V _{CC}	Supply voltage pin for the IC.	
5	IFOUT	IF output pin. IF amplifier is designed as a single-ended push-pull amplifier. This pin is an emitter follower output with a wideband 50 Ω impedance.	
6	GND	GND pin for the IC.	
7	RF IN2 (Bypass)	<p>Pins 7 and 8 are inputs to a double-balance mixer. Either pin can be used for input and bypass.</p>	
8	RF IN1		

TYPICAL PERFORMANCE CURVES ($T_A = 25^\circ\text{C}$)

CIRCUIT CURRENT vs. SUPPLY VOLTAGE

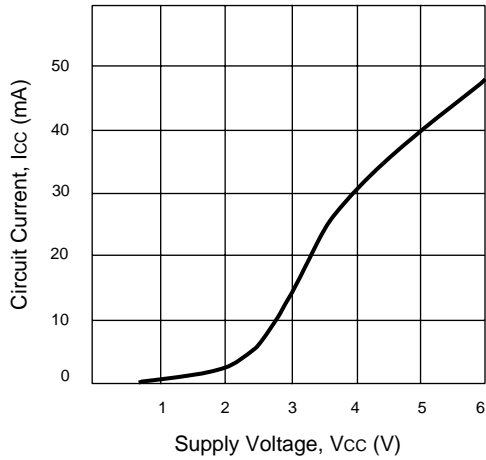

OUTPUT POWER AND INTERMODULATION DISTORTION vs. INPUT POWER

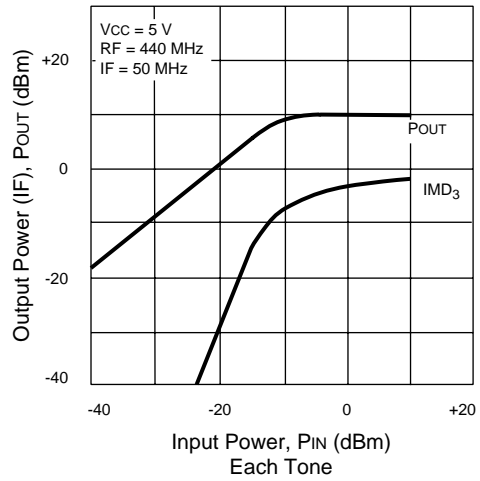

1% CROSS MODULATION vs. FREQUENCY

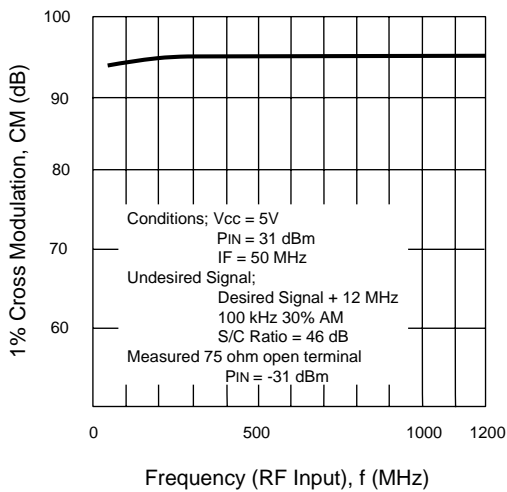

OSC-FREQUENCY STABILITY vs. FREQUENCY

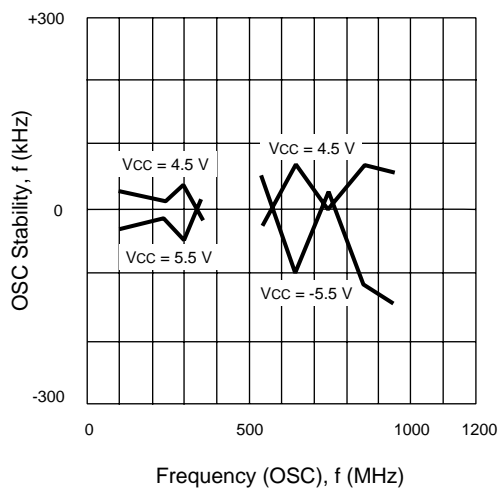

EQUIVALENT CIRCUIT

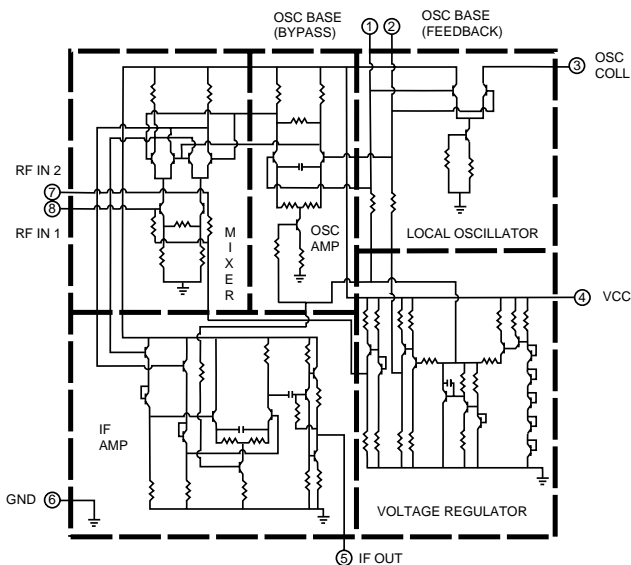

CONVERSION GAIN AND NOISE FIGURE vs. FREQUENCY

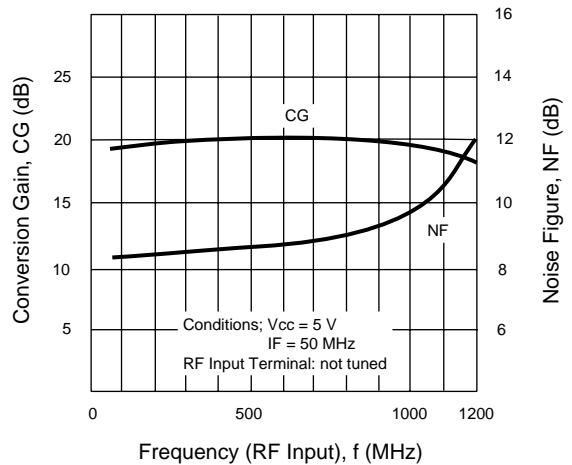

TEST CIRCUITS

Figure 1

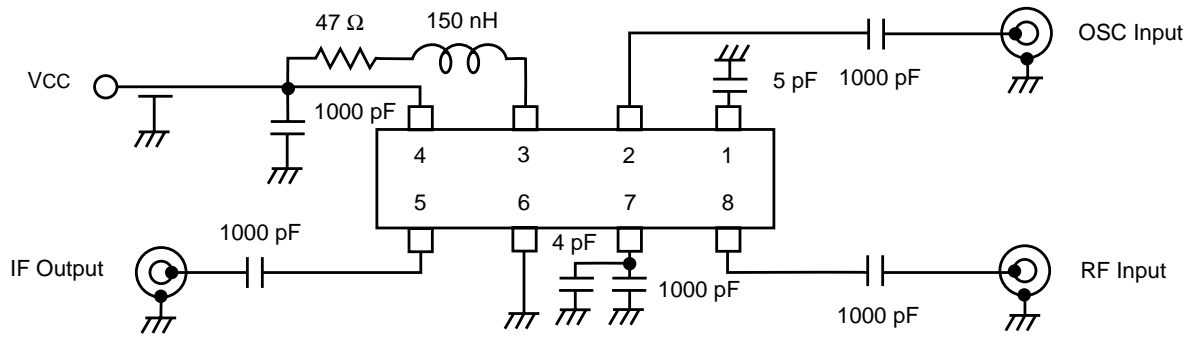
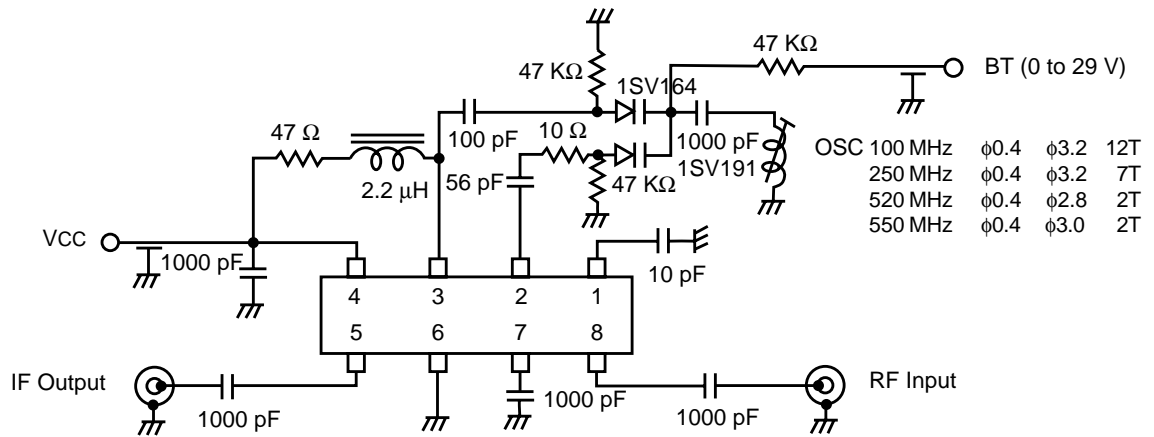
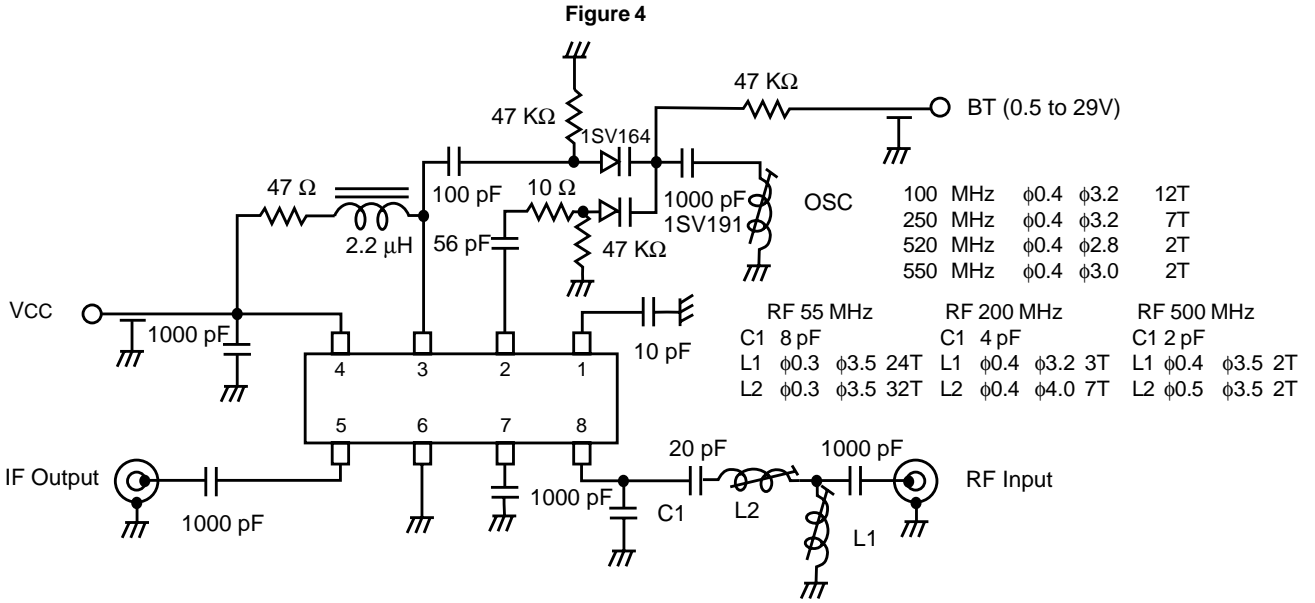

Figure 2



TYPICAL APPLICATION CIRCUIT



APPLICATION BLOCK DIAGRAM FOR T.V. TUNER

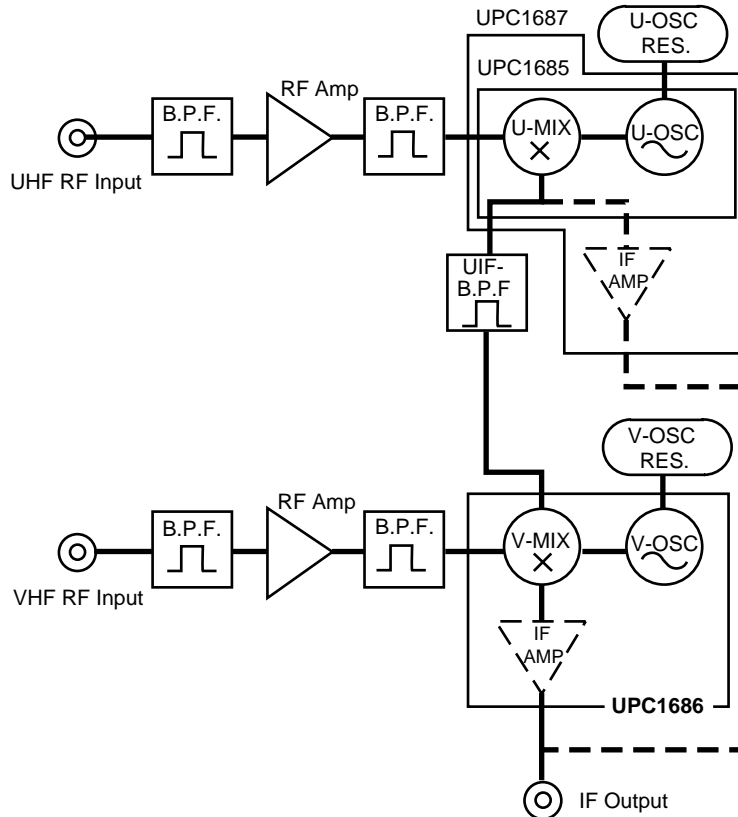

APPLICATION CIRCUIT FOR T.V. TUNER

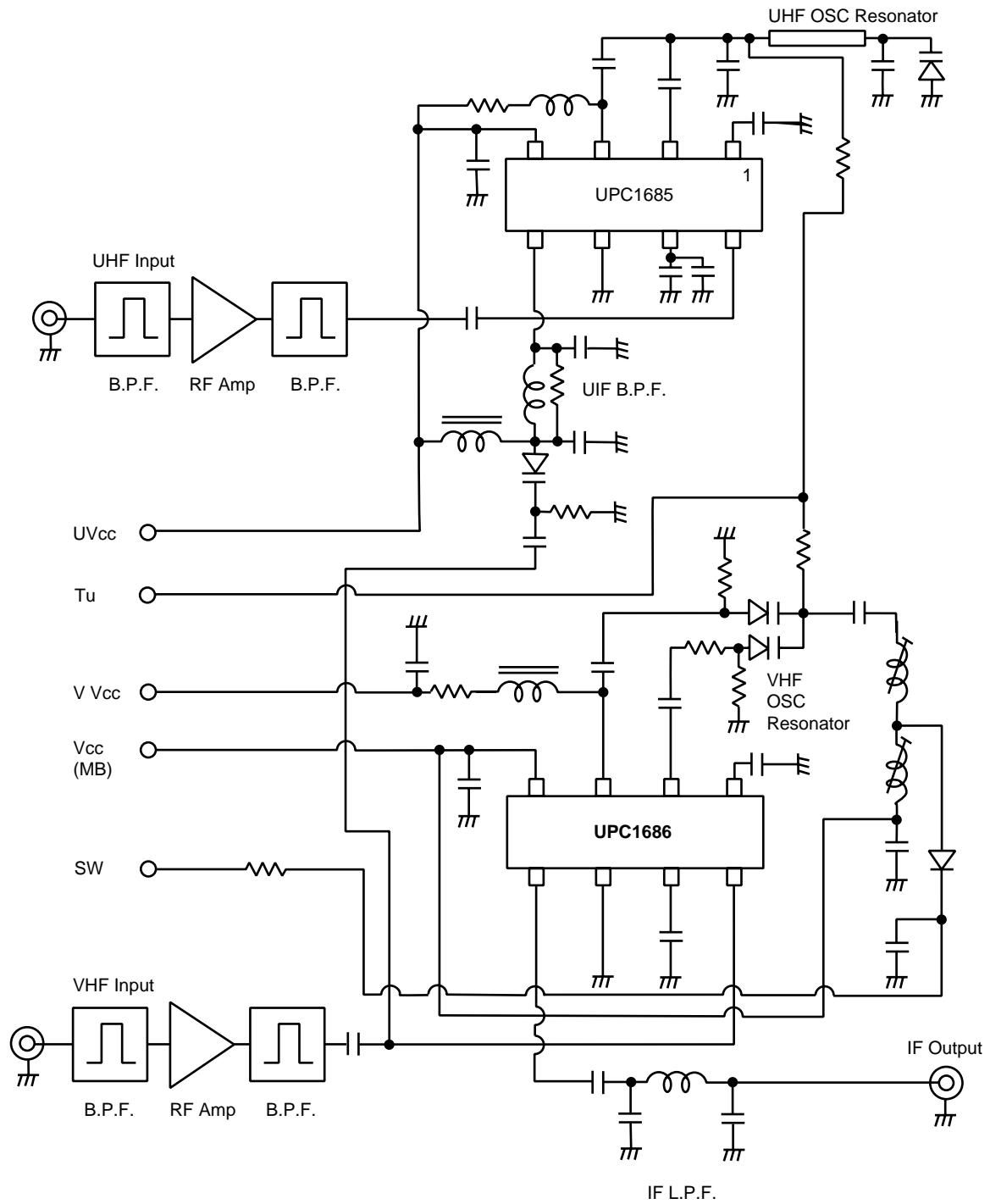

OUTLINE DIMENSIONS (Units in mm)

PACKAGE OUTLINE S08

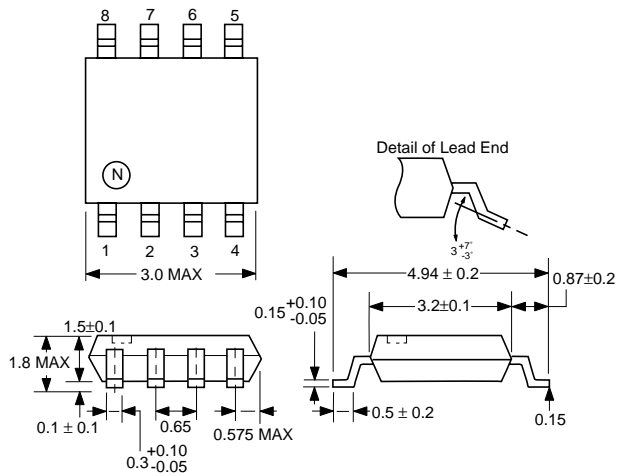

PIN CONNECTION

1. OSC-Base (Bypass)
2. OSC-Base (Feedback)
3. OSC-Collector (Coupling)*
4. Vcc
5. IF OUT
6. GND
7. RF IN (Bypass)
8. RF IN

ORDERING INFORMATION

PART NUMBER	QUANTITY
UPC1686GV-E1	1000/REEL