

TOSHIBA Transistor Silicon NPN Epitaxial Type (PCT Process)

## RN1321A,RN1322A,RN1323A,RN2324A RN1325A,RN1326A,RN1327A

Switching, Inverter Circuit, Interface Circuit  
And Driver Circuit Applications

- High current driving is possible.
- Since bias resistors are built in the transistor, the miniaturization of the apparatus by curtailment of the number of parts and laborsaving of an assembly are possible.
- Many kinds of resistance value are lined up in order to support various kinds of circuit design.
- Complementary to RN2321A~RN2327A
- Low  $V_{CE(sat)}$  enable to be low power dissipation on high current driving.

### Equivalent Circuit And Bias Resistance Values

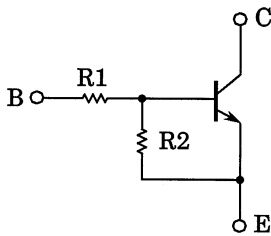

Type No.	R1 (kΩ)	R2 (kΩ)
RN1321A	1	1
RN1322A	2.2	2.2
RN1323A	4.7	4.7
RN1324A	10	10
RN1325A	0.47	10
RN1326A	1	10
RN1327A	2.2	10

Unit in mm

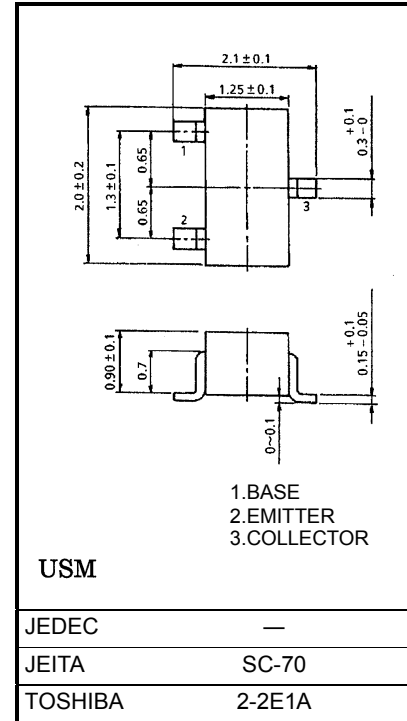

Weight : 0.006mg(typ.)

### Maximum Ratings (Ta = 25°C)

Characteristic	Symbol	Rating	Unit	
Collector-base voltage	RN1321A~1327A	$V_{CBO}$	15	V
Collector-emitter voltage		$V_{CEO}$	12	V
Emitter-base voltage	RN1321A~1324A	$V_{EBO}$	10	V
	RN1325A, 1326A		5	
	RN1327A		6	
Collector current	RN1321A~1327A	$I_C$	500	mA
Collector power dissipation		$P_C$	100	mW
Junction temperature		$T_j$	150	°C
Storage temperature range		$T_{stg}$	-55~150	°C

**Electrical Characteristics (Ta = 25°C)**

Characteristic		Symbol	Test Circuit	Test Condition	Min	Typ.	Max	Unit
Collector cut-off current	RN1321A~1327A	$I_{CBO}$	—	$V_{CB} = 15V, I_E = 0$	—	—	100	nA
		$I_{CEO}$		$V_{CE} = 12V, I_B = 0$	—	—	500	
Emitter cut-off current	RN1321A	$I_{EBO}$	—	$V_{EB} = 10V, I_C = 0$	3.85	—	7.14	mA
	RN1322A				1.75	—	3.25	
	RN1323A				0.82	—	1.52	
	RN1324A			0.38	—	0.71		
	RN1325A			$V_{EB} = 5V, I_C = 0$	0.365	—	0.682	
	RN1326A				0.35	—	0.65	
	RN1327A				$V_{EB} = 6V, I_C = 0$	0.378	—	
DC current gain	RN1321A	$h_{FE}$	—	$V_{CE} = 1V, I_C = 50mA$	35	—	—	
	RN1322A				65	—	—	
	RN1323A				100	—	—	
	RN1324A				140	—	—	
	RN1325A				140	—	—	
	RN1326A				140	—	—	
	RN1327A				140	—	—	
Collector-emitter saturation voltage	RN1321A	$V_{CE(sat)}$	—	$I_C = 50mA, I_B = 2mA$	—	—	0.25	V
	RN1322A~1327A			$I_C = 50mA, I_B = 1mA$				
Input voltage (ON)	RN1321A	$V_{I(ON)}$	—	$V_{CE} = 0.2V, I_C = 50mA$	1.0	—	2.4	V
	RN1322A				1.1	—	2.7	
	RN1323A				1.3	—	3.5	
	RN1324A				1.5	—	5.2	
	RN1325A				0.5	—	1.2	
	RN1326A				0.6	—	1.4	
	RN1327A				0.7	—	1.9	
Input voltage (OFF)	RN1321A~1324A	$V_{I(OFF)}$	—	$V_{CE} = 5V, I_C = 0.1mA$	0.8	—	1.4	V
	RN1325A, 1326A				0.4	—	0.8	
	RN1327A				0.5	—	1.0	
Transition frequency	RN1321A~1327A	$f_T$	—	$V_{CE} = 5V, I_C = 20mA$	—	300	—	MHz
Collector Output capacitance	RN1321A~1327A	$C_{ob}$	—	$V_{CB} = 10V, I_E = 0, f = 1MHz$	—	4	—	pF
Input resistor	RN1321A	R1	—	—	0.7	1	1.3	kΩ
	RN1322A				1.54	2.2	2.86	
	RN1323A				3.29	4.7	6.11	
	RN1324A				7	10	13	
	RN1325A				0.329	0.47	0.611	
	RN1326A				0.7	1	1.3	
	RN1327A				1.54	2.2	2.86	
Resistor ratio	RN1321A~1324A	R1/R2	—	—	0.85	1.00	1.15	
	RN1325A				0.040	0.047	0.054	
	RN1326A				0.085	0.100	0.115	
	RN1327A				0.187	0.220	0.253	

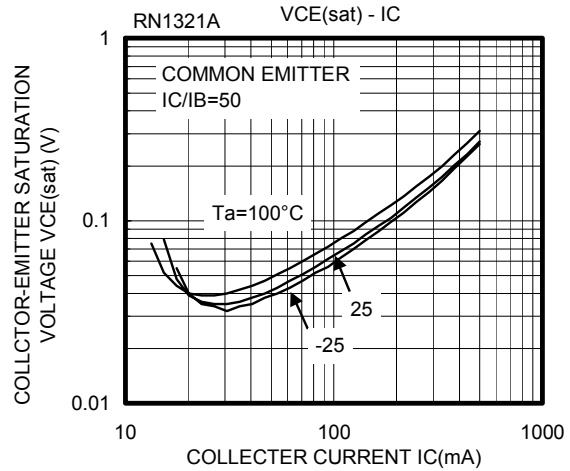
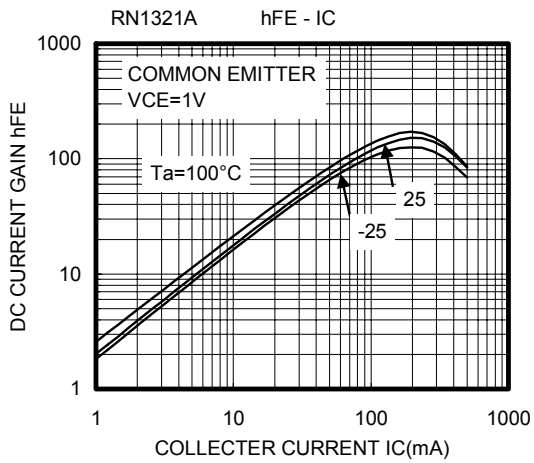
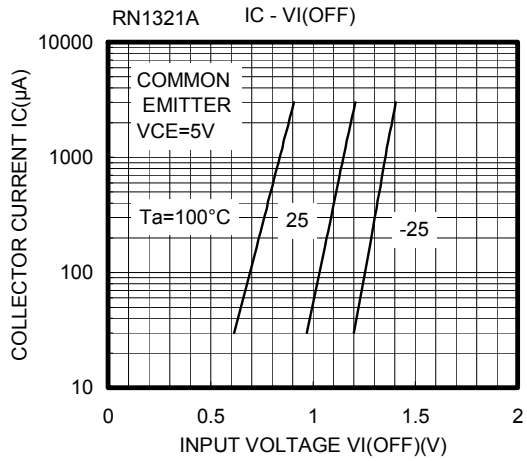
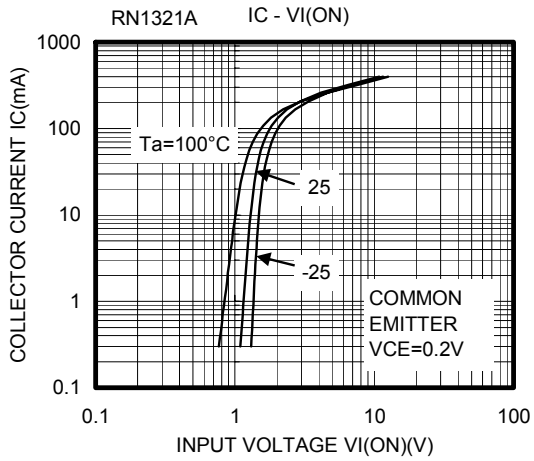

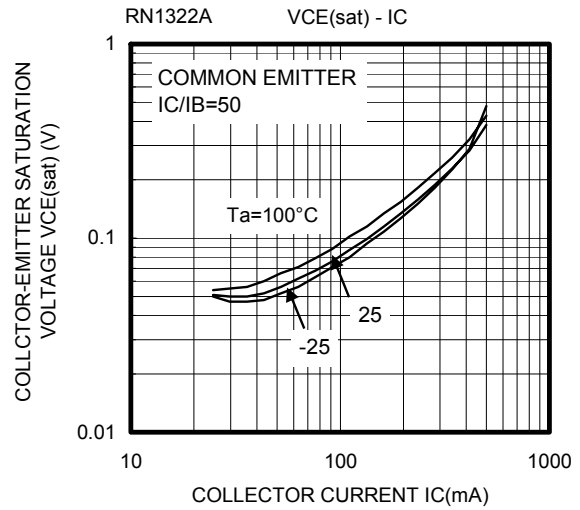
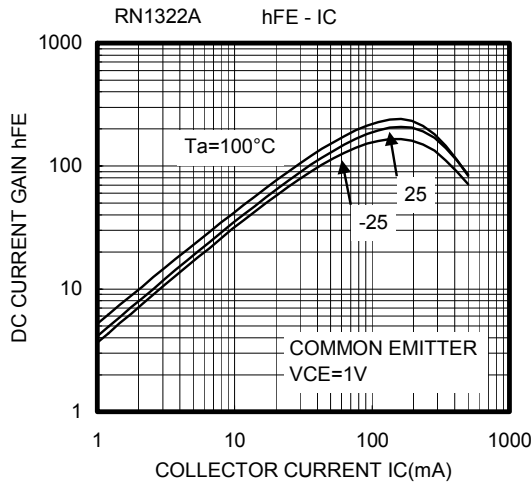
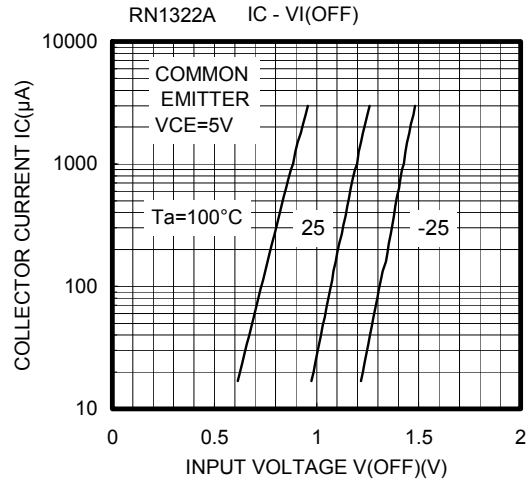
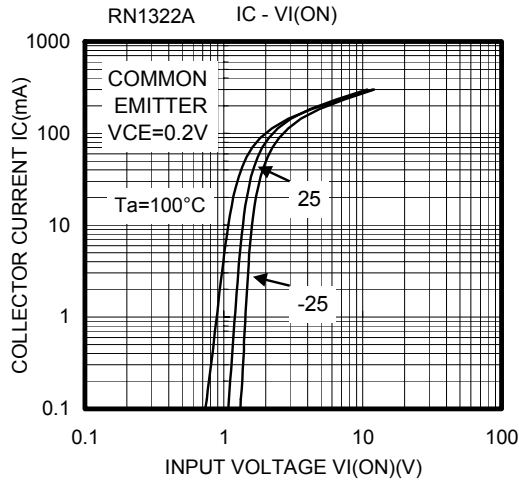

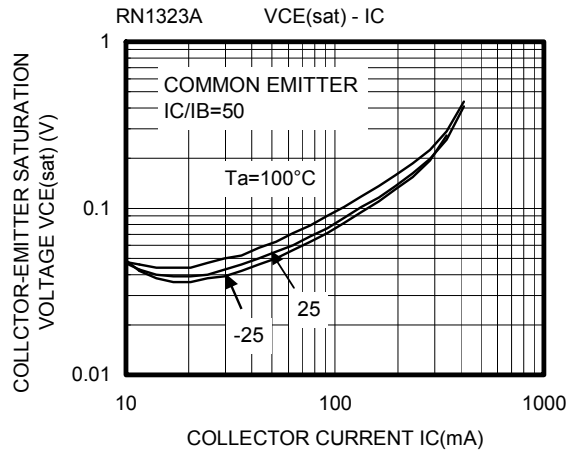
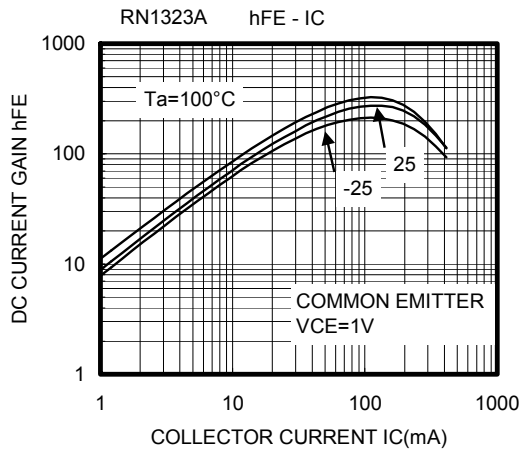
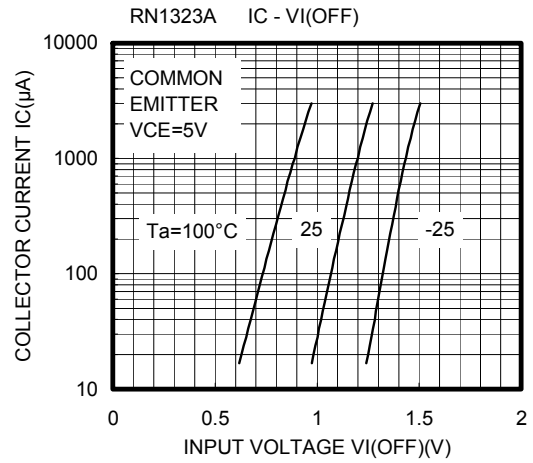
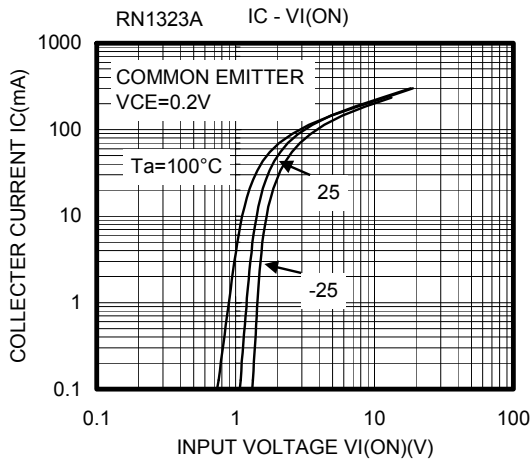

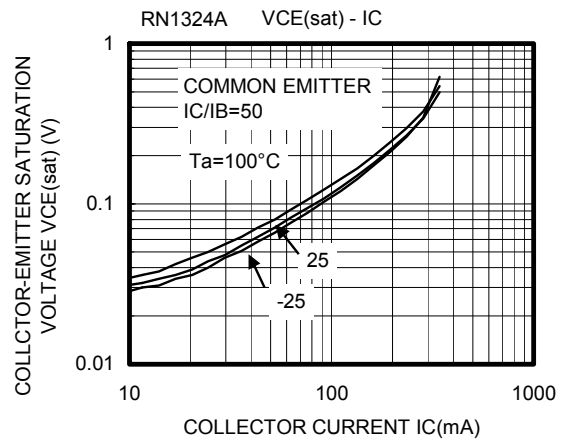
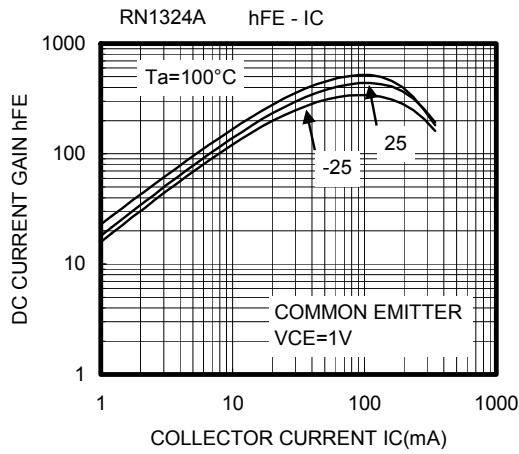
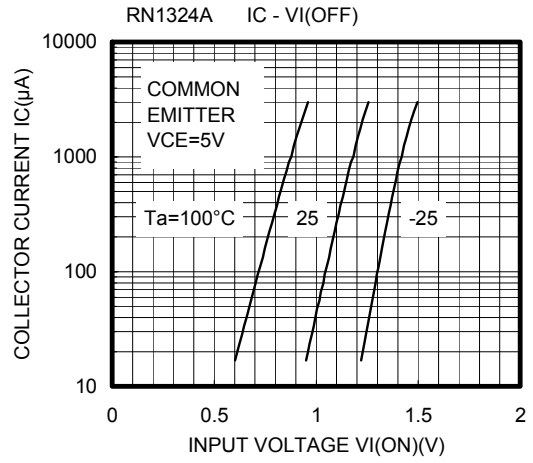
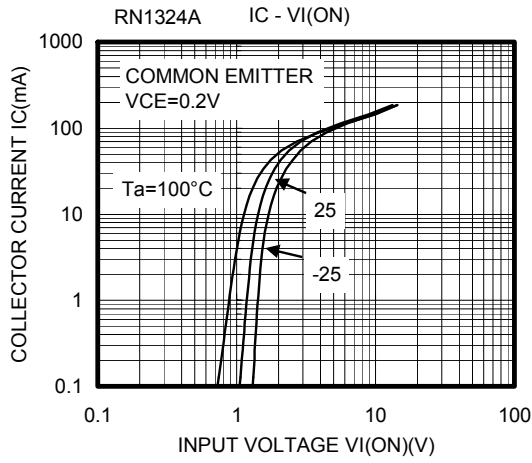

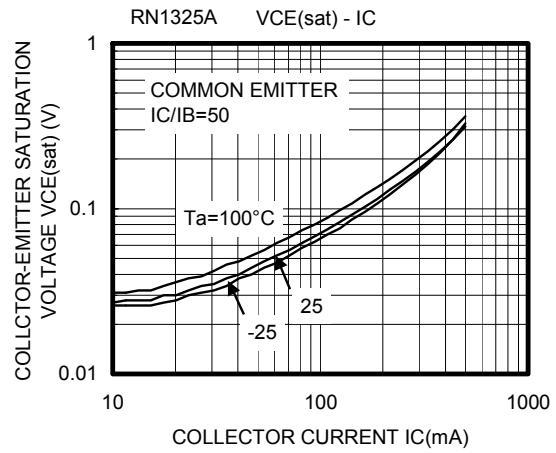
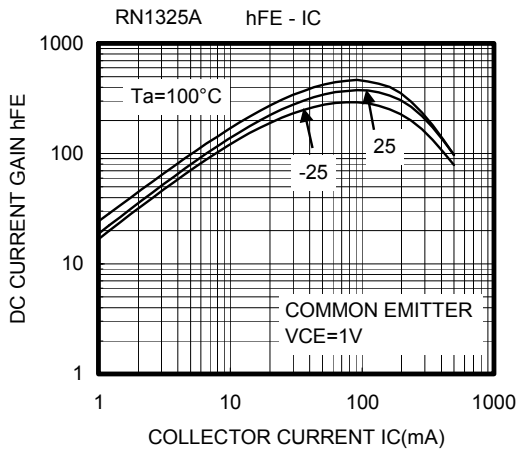
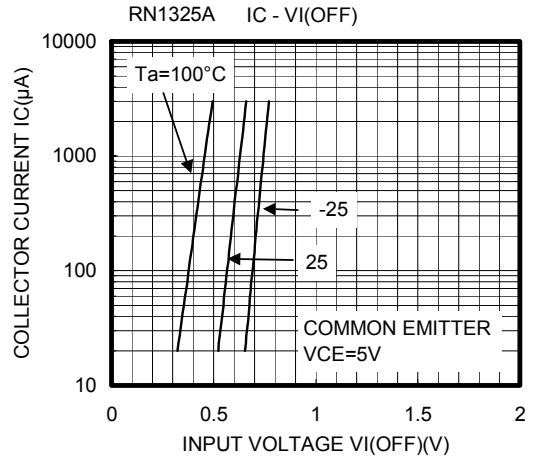
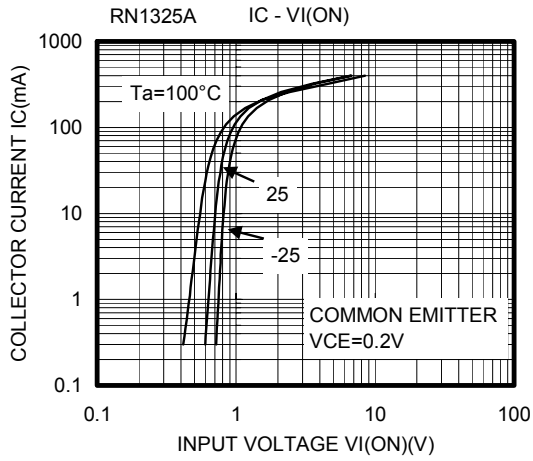

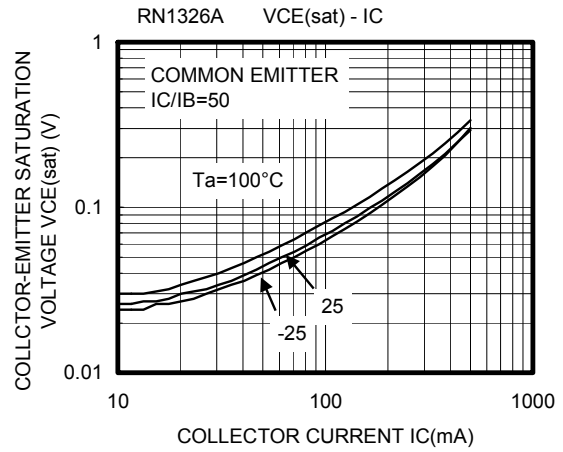
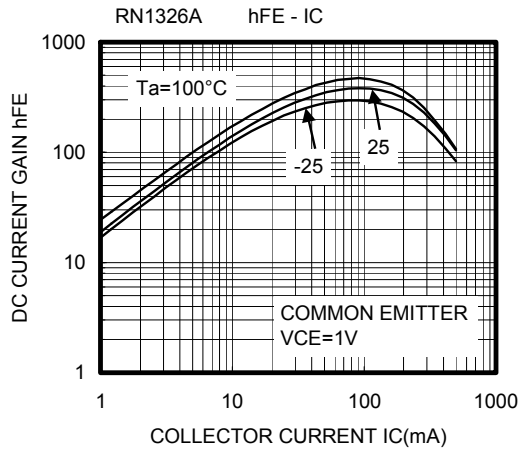
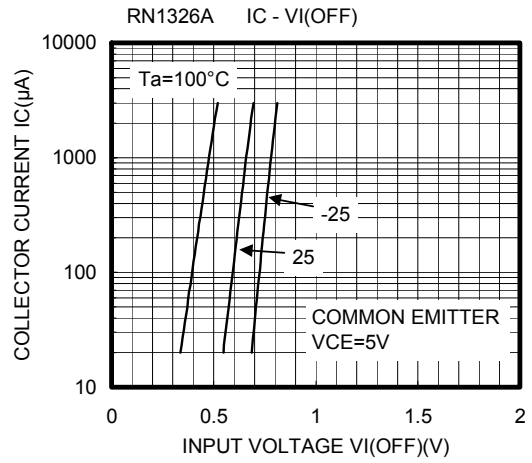
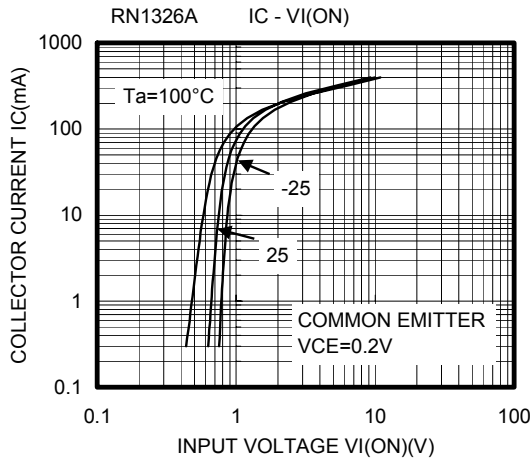



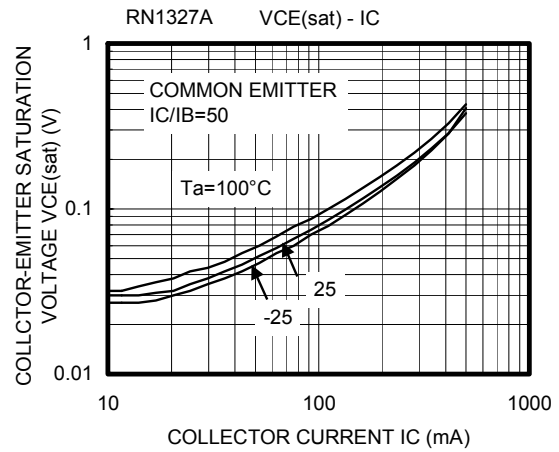
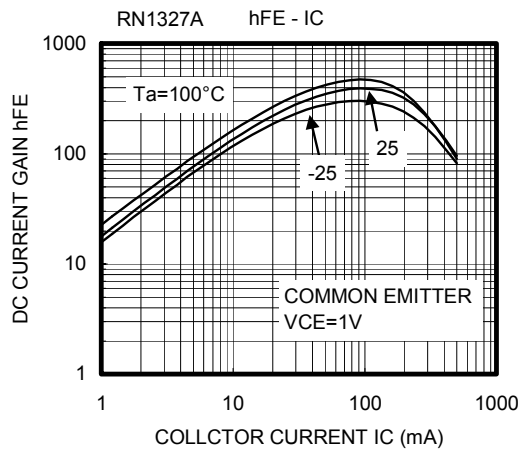
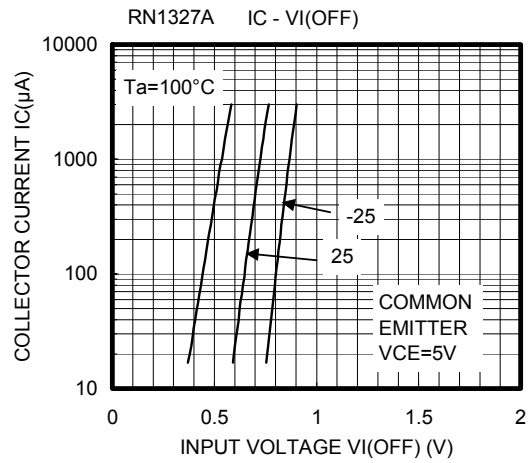
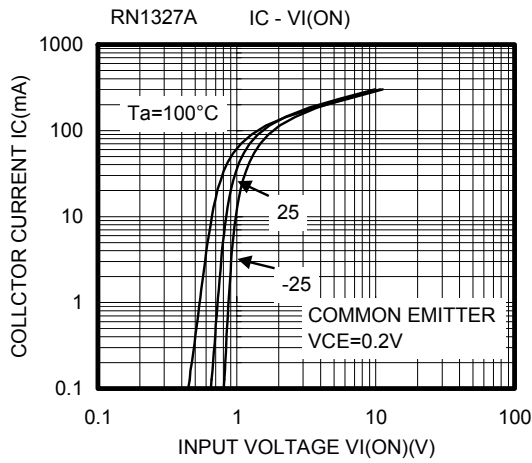

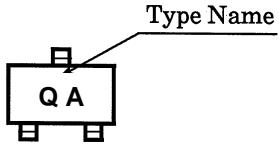
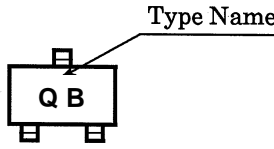
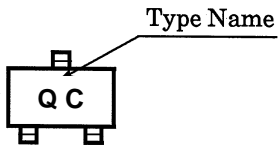
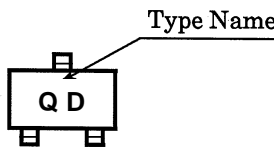
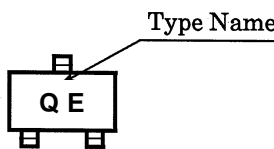
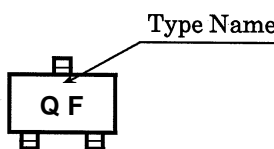
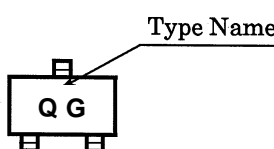
Type Name	Marking
RN1321A	
RN1322A	
RN1323A	
RN1324A	
RN1325A	
RN1326A	
RN1327A	

**RESTRICTIONS ON PRODUCT USE**

030619EAA

- The information contained herein is subject to change without notice.
- The information contained herein is presented only as a guide for the applications of our products. No responsibility is assumed by TOSHIBA for any infringements of patents or other rights of the third parties which may result from its use. No license is granted by implication or otherwise under any patent or patent rights of TOSHIBA or others.
- TOSHIBA is continually working to improve the quality and reliability of its products. Nevertheless, semiconductor devices in general can malfunction or fail due to their inherent electrical sensitivity and vulnerability to physical stress. It is the responsibility of the buyer, when utilizing TOSHIBA products, to comply with the standards of safety in making a safe design for the entire system, and to avoid situations in which a malfunction or failure of such TOSHIBA products could cause loss of human life, bodily injury or damage to property.  
In developing your designs, please ensure that TOSHIBA products are used within specified operating ranges as set forth in the most recent TOSHIBA products specifications. Also, please keep in mind the precautions and conditions set forth in the "Handling Guide for Semiconductor Devices," or "TOSHIBA Semiconductor Reliability Handbook" etc..
- The TOSHIBA products listed in this document are intended for usage in general electronics applications (computer, personal equipment, office equipment, measuring equipment, industrial robotics, domestic appliances, etc.). These TOSHIBA products are neither intended nor warranted for usage in equipment that requires extraordinarily high quality and/or reliability or a malfunction or failure of which may cause loss of human life or bodily injury ("Unintended Usage"). Unintended Usage include atomic energy control instruments, airplane or spaceship instruments, transportation instruments, traffic signal instruments, combustion control instruments, medical instruments, all types of safety devices, etc.. Unintended Usage of TOSHIBA products listed in this document shall be made at the customer's own risk.
- TOSHIBA products should not be embedded to the downstream products which are prohibited to be produced and sold, under any law and regulations.