

Proximity Detector

Description

The CS209A is a bipolar monolithic integrated circuit for use in metal detection/proximity sensing applications. The IC (see block diagram) contains two on-chip current regulators, oscillator and low-level feedback circuitry, peak detection/demodulation circuit, a comparator and two complementary output stages.

The oscillator, along with an external LC network, provides controlled oscillations where amplitude is highly dependent on the Q of the LC tank. During low Q conditions, a variable low-level

feedback circuit provides drive to maintain oscillation. The peak demodulator senses the negative portion of the oscillator envelop and provides a demodulated waveform as input to the comparator. The comparator sets the states of the complementary outputs by comparing the input from the demodulator to an internal reference. External loads are required for the output pins.

A transient suppression circuit is included to absorb negative transients at the tank circuit terminal.

Absolute Maximum Ratings

Supply Voltage	24V
Power Dissipation ($T_A = 125^\circ\text{C}$)	200mW
Storage Temperature Range	-55°C to $+165^\circ\text{C}$
Junction Temperature	-40°C to $+150^\circ\text{C}$
Electrostatic Discharge (except TANK pin)	2kV
Lead Temperature Soldering	
Wave Solder(through hole styles only)	10 sec. max, 260°C peak
Reflow (SMD styles only)	60 sec. max above 183°C , 230°C peak

Block Diagram

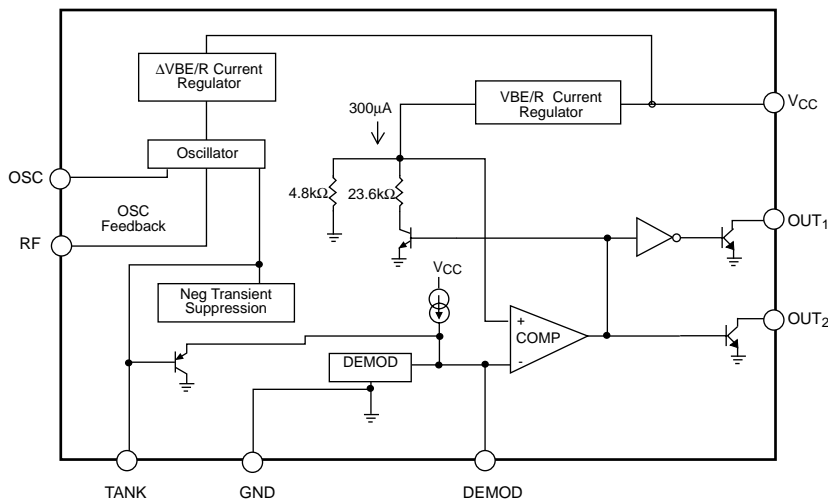

Features

- Separate Current Regulator for Oscillator
- Negative Transient Suppression
- Variable Low-Level Feedback
- Improved Performance over Temperature
- 6mA Supply Current Consumption at $V_{CC} = 12\text{V}$
- Output Current Sink Capability
20mA at $4V_{CC}$
100mA at $24V_{CC}$

Package Options

14L SO

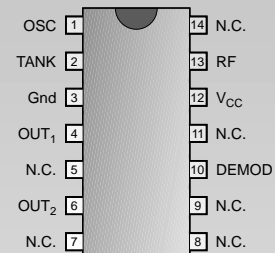

8L PDIP & SO

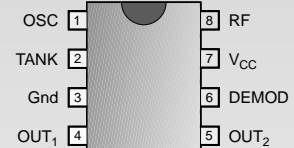

Electrical Characteristics: $-40^{\circ}\text{C} \leq T_A \leq 125^{\circ}\text{C}$ unless otherwise specified

PARAMETER	TEST CONDITIONS	MIN	TYP	MAX	UNIT
Supply Current I_{CC}	$V_{CC} = 4\text{V}$		3.5	6.0	mA
	$V_{CC} = 12\text{V}$		6.0	11.6	mA
	$V_{CC} = 24\text{V}$		11.0	20.0	mA
Tank Current	$V_{CC} = 20\text{V}$	-550	-300	-100	μA
Demodulator Charge Current	$V_{CC} = 20\text{V}$	-60	-30	-10	μA
Output Leakage Current	$V_{CC} = 24\text{V}$		0.01	10.00	μA
Output V_{SAT}	$V_{CC} = 4\text{V}$, $I_S = 20\text{mA}$		60	200	mV
	$V_{CC} = 24\text{V}$, $I_S = 100\text{mA}$		200	500	mv
Oscillator Bias	$V_{CC} = 20\text{V}$	1.1	1.9	2.5	V
Feedback Bias	$V_{CC} = 20\text{V}$	1.1	1.9	2.5	V
Osc - Rf Bias	$V_{CC} = 20\text{V}$	-250	100	550	mV
Protect Voltage	$I_{TANK} = -10\text{mA}$	-10.0	-8.9	-7.0	V
Detect Threshold		720	1440	1950	mV
Release Threshold		550	1200	1700	mV

Package Pin Description

PACKAGE PIN#		PIN SYMBOL	FUNCTION
8L PDIP & SO	14L SO		
1	1	OSC	Adjustable feedback resistor connected between OSC and RF sets detection range.
2	2	TANK	Connects to parallel tank circuit.
3	3	Gnd	Ground connection.
4	4	OUT ₁	Complementary open collector output; When OUT ₁ = LOW, metal is present.
5	6	OUT ₂	Complementary open collector output; When OUT ₂ = HIGH, metal is present.
6	10	DEMOD	Input to comparator controlling OUT ₁ and OUT ₂ .
7	12	V _{CC}	Supply voltage.
8	13	RF	Adjustable feedback resistor connected between OSC and RF set detection range.
	5,7,8,9,11,14	NC	No Connection.

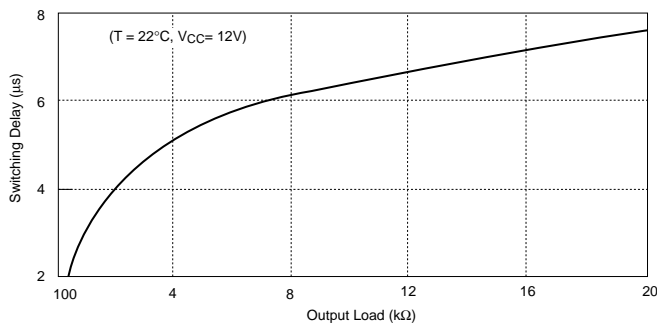
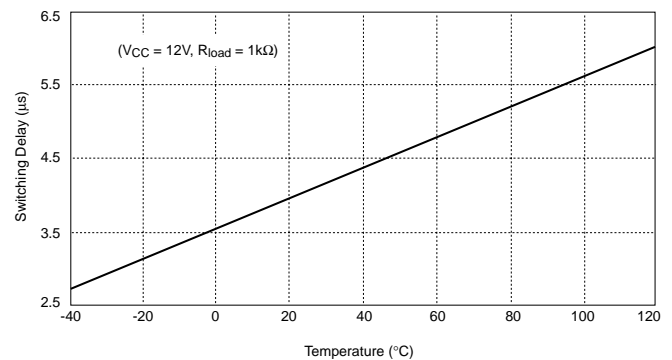
Typical Performance Characteristics
Output Switching Delay vs. Output Load

Output Switching Delay vs. Temperature

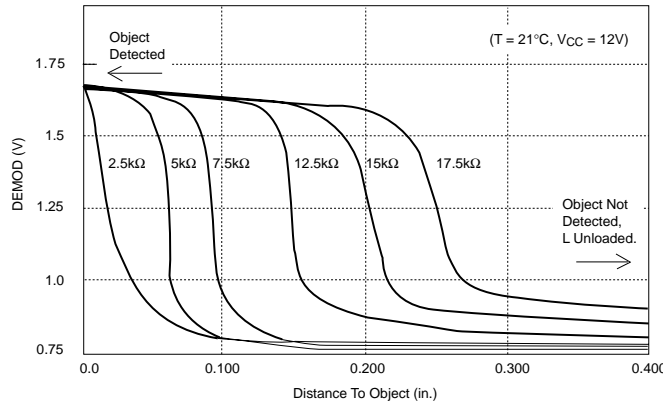
Demodulator Voltage vs. Distance for Different RF



Principle of Operation

The CS209A is a metal detector circuit which operates on the principle of detecting a reduction in Q of an inductor when it is brought into close proximity of metal. The CS209A contains an oscillator set up by an external parallel resonant tank and a feedback resistor connected between OSC and RF. (See Test and Applications Diagram) The impedance of a parallel resonant tank is highest when the frequency of the source driving it is equal to the tank's resonant frequency. In the CS209A the internal oscillator operates close to the resonant frequency of the tank circuit selected. As a metal object is brought close to the inductor, the amplitude of the voltage across the tank gradually begins to drop. When the envelope of the oscillation reaches a certain level, the IC causes the output stages to switch states.

The detection is performed as follows: A capacitor connected to DEMOD is charged via an internal 30µA current source. This current, however, is diverted away from the capacitor in proportion to the negative bias generated by the tank at TANK. Charge is therefore removed from the capacitor tied to DEMOD on every negative half cycle of the resonant voltage. (See Figure 1) The voltage on the capacitor at DEMOD, a DC voltage with ripple, is then directly compared to an internal 1.44V reference. When the internal comparator trips it turns on a transistor which places a 23.6kΩ resistor in parallel to the 4.8kΩ. The resulting reference then becomes approximately 1.2V. This hysteresis is necessary for preventing false triggering.

The feedback potentiometer connected between OSC and RF is adjusted to achieve a certain detection distance range. The larger the resistance the greater the trip-point distance (See graph Demodulator Voltage vs Distance for Different RF). Note that this is a plot representative of one particular set-up since detection distance is dependent on the Q of the tank. Note also from the graph that the capacitor voltage corresponding to the greatest detection distance has a higher residual voltage when the metal object

is well outside the trip point. Higher values of feedback resistance for the same inductor Q will therefore eventually result in a latched-ON condition because the residual voltage will be higher than the comparator's thresholds.

As an example of how to set the detection range, place the metal object at the maximum distance from the inductor the circuit is required to detect, assuming of course the Q of the tank is high enough to allow the object to be within the IC's detection range. Then adjust the potentiometer to obtain a lower resistance while observing one of the CS209A outputs return to its normal state (see Test and Applications Diagram). Readjust the potentiometer slowly toward a higher resistance until the outputs have switched to their tripped condition. Remove the metal and confirm that the outputs switch back to their normal state. Typically the maximum distance range the circuit is capable of detecting is around 0.3 inch. The higher the Q, the higher the detection distance.

For this application it is recommended to use a core which concentrates the magnetic field in only one direction. This is accomplished very well with a pot core half. The next step is to select a core material with low loss factor (inverse of Q). The loss factor can be represented by a resistance in series with the inductor which arises from core losses and is a function of frequency.

The final step in obtaining a high Q inductor is the selection of wire size. The higher the frequency the faster the decrease in current density towards the center of the wire. Thus most of the current flow is concentrated on the surface of the wire resulting in a high AC resistance. LITZ wire is recommended for this application. Considering the many factors involved, it is also recommended to operate at a resonant frequency between 200 and 700kHz. The formula commonly used to determine the Q for parallel resonant circuits is:

$$Q_P \cong \frac{R}{2\pi f_R L}$$

where R is the effective resistance of the tank. The resistance component of the inductor consists primarily of core losses and "skin effect" or AC resistance.

The resonant capacitor should be selected to resonate with the inductor within the frequency range recommended in order to yield the highest Q . The capacitor type should be selected to have low ESR: multilayer ceramic for example.

Detection distances vary for different metals. Following are different detection distances for some selected metals and metal objects relative to one particular circuit set-up:

Commonly encountered metals:

• Stainless steel	0.101"
• Carbon steel	0.125"
• Copper	0.044"
• Aluminum	0.053"
• Brass	0.052"

Coins:

• US Quarter	0.055"
• Canadian Quarter	0.113"
• 1 German Mark	0.090"
• 1 Pound Sterling	0.080"
• 100 Japanese Yen	0.093"
• 100 Italian Lira	0.133"

12 oz. soda can: 0.087"

Note that the above is only a comparison among different metals and no attempt was made to achieve the greatest detection distance.

A different type of application involves, for example, detecting the teeth of a rotating gear. For these applications the capacitor on DEMOD should not be selected too small (not below 1000pF) where the ripple becomes too large and not too large (not greater than 0.01 μ F) that the response time is too slow. Figure 1 for example shows the capacitor ripple only and Figure 2 shows the entire capacitor voltage and the output pulses for an 8-tooth gear rotating at about 2400 rpm using a 2200pF capacitor on the DEMOD pin.

Because the output stages go into hard saturation, a time interval is required to remove the stored base charge resulting in both outputs being low for approximately 3 μ s (see Output Switching Delay vs. Temperature graph). If more information is required about output switching characteristics please consult the factory.

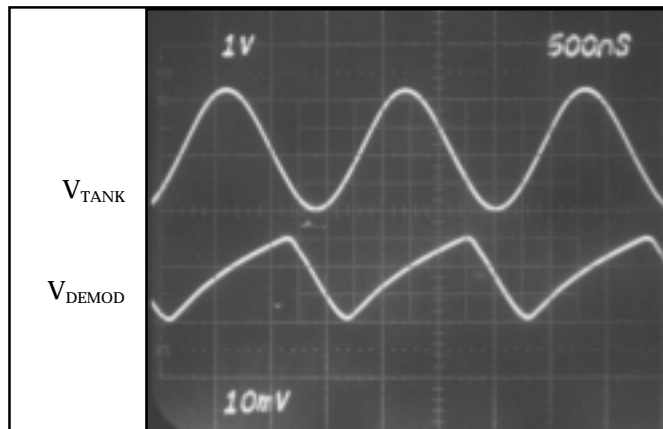

Figure 1. Capacitor ripple.

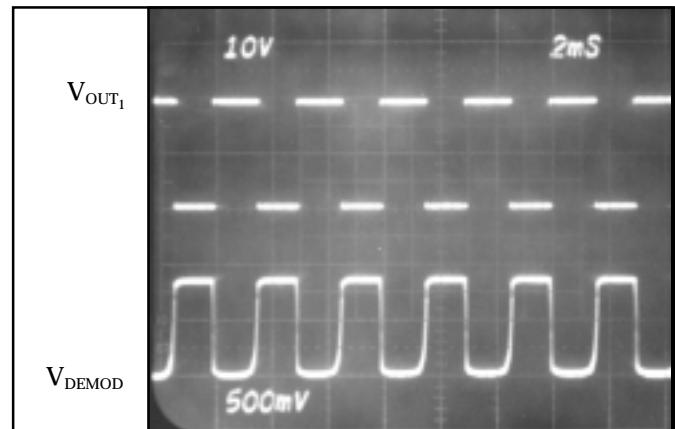
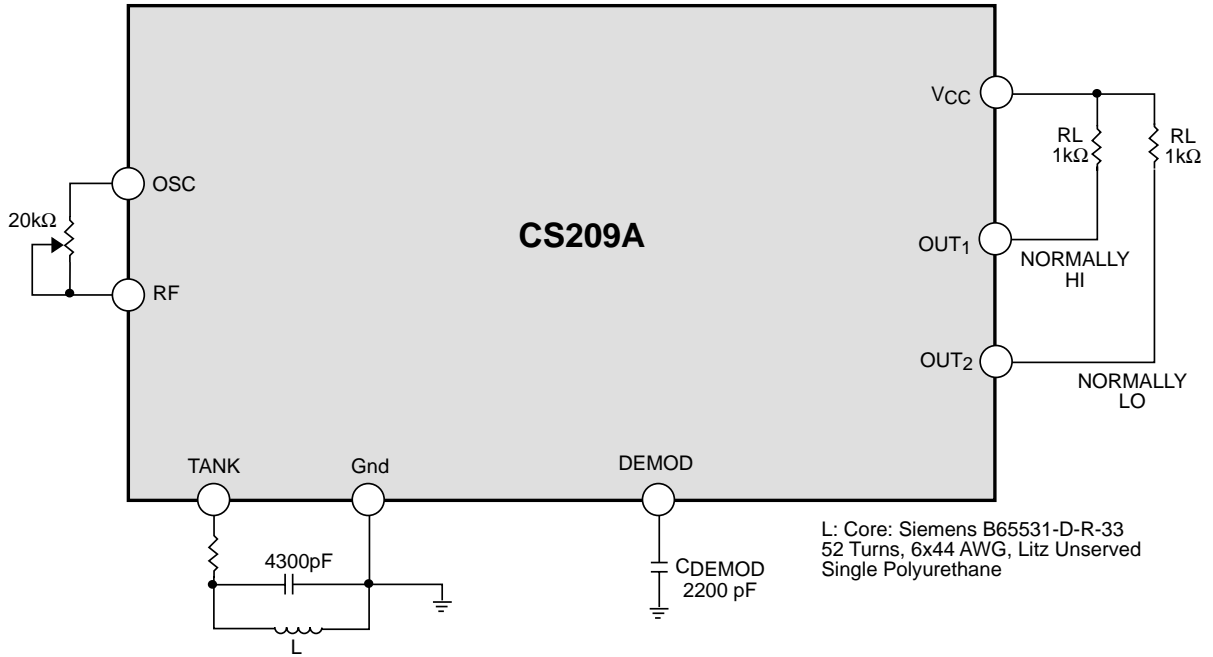

Figure 2. Output pulse for an 8 tooth gear.



Package Specification

PACKAGE DIMENSIONS IN mm (INCHES)

Lead Count	D			
	Metric		English	
	Max	Min	Max	Min
8L PDIP	10.16	9.02	.400	.355
8L SO	5.00	4.80	.197	.189
14L SO	8.75	8.55	.344	.337

PACKAGE THERMAL DATA

Thermal Data		8L PDIP	8L SO	14L SO	
$R_{\theta JC}$	typ	52	45	30	$^{\circ}\text{C}/\text{W}$
$R_{\theta JA}$	typ	100	165	125	$^{\circ}\text{C}/\text{W}$

Plastic DIP (N); 300 mil wide

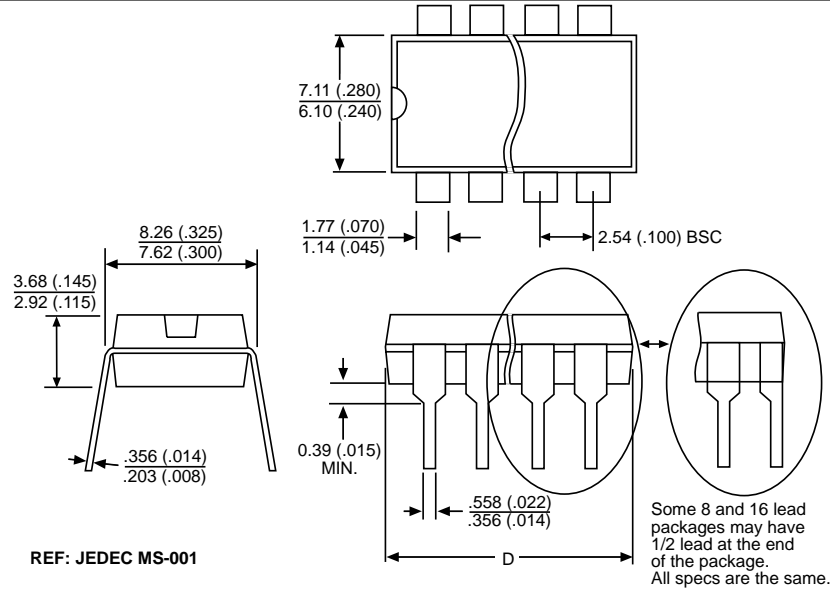

Surface Mount Narrow Body (D); 150 mil wide

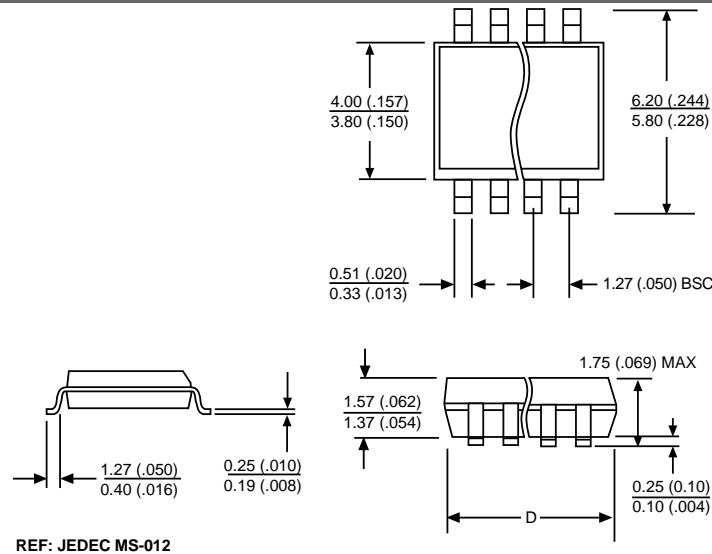

Ordering Information

Part Number	Description
CS209AYN8	8 L PDIP
CS209AYD8	8L SO Narrow
CS209AYDR8	8L SO Narrow (<i>tape & reel</i>)
CS209AYD14	14L SO Narrow
CS209AYDR14	14L SO Narrow (<i>tape & reel</i>)

ON Semiconductor and the ON Logo are trademarks of Semiconductor Components Industries, LLC (SCILLC). ON Semiconductor reserves the right to make changes without further notice to any products herein. For additional information and the latest available information, please contact your local ON Semiconductor representative.

