

DATA SHEET

For a complete data sheet, please also download:

- The IC06 74HC/HCT/HCU/HCMOS Logic Family Specifications
- The IC06 74HC/HCT/HCU/HCMOS Logic Package Information
- The IC06 74HC/HCT/HCU/HCMOS Logic Package Outlines

74HC/HCT7080 16-bit even/odd parity generator/checker

Product specification
File under Integrated Circuits, IC06

December 1990

16-bit even/odd parity generator/checker

74HC/HCT7080

FEATURES

- Word-length easily expanded by cascading
- Generates either even or odd parity for 16-data bits
- Output capability: standard
- I_{CC} category: MSI

GENERAL DESCRIPTION

The 74HC/HCT7080 are high-speed Si-gate CMOS devices. They are specified in compliance with JEDEC standard no. 7A.

The 74HC/HCT7080 are 16-bit parity generators or checkers commonly used to detect errors in high-speed data transmission or data retrieval systems.

The even and odd parity output is available for generating or checking even/odd parity up to 16-bits.

The even/odd parity output (E/\bar{O}) is HIGH when an even number of data inputs (I_0 to I_{15}) are HIGH and the cascade/even-odd-changing input (\bar{X}) is HIGH.

Expansion to larger word sizes is accomplished by connecting the even/odd parity output (E/\bar{O}) to the cascade/even-odd-changing input (\bar{X}) of the final stage.

QUICK REFERENCE DATA

GND = 0 V; $T_{amb} = 25\text{ }^{\circ}\text{C}$; $t_r = t_f = 6\text{ ns}$

| SYMBOL | PARAMETER | CONDITIONS | TYPICAL | | UNIT |
|-------------------|---|--|---------|-----|------|
| | | | HC | HCT | |
| t_{PHL}/t_{PLH} | propagation delay | $C_L = 15\text{ pF}$; $V_{CC} = 5\text{ V}$ | | | |
| | I_n to E/\bar{O} | | 29 | 32 | ns |
| | \bar{X} to E/\bar{O} | | 12 | 15 | ns |
| C_I | input capacitance | | 3.5 | 3.5 | pF |
| C_{PD} | power dissipation capacitance per package | notes 1 and 2 | 24 | 25 | pF |

Notes

1. C_{PD} is used to determine the dynamic power dissipation (P_D in μW):

$$P_D = C_{PD} \times V_{CC}^2 \times f_i + \sum (C_L \times V_{CC}^2 \times f_o) \text{ where:}$$

f_i = input frequency in MHz

f_o = output frequency in MHz

$\sum (C_L \times V_{CC}^2 \times f_o)$ = sum of outputs

C_L = output load capacitance in pF

V_{CC} = supply voltage in V

2. For HC the condition is $V_I = \text{GND to } V_{CC}$
For HCT the condition is $V_I = \text{GND to } V_{CC} - 1.5\text{ V}$

ORDERING INFORMATION

See "74HC/HCT/HCU/HCMOS Logic Package Information".

16-bit even/odd parity generator/checker

74HC/HCT7080

PIN DESCRIPTION

| PIN NO. | SYMBOL | NAME AND FUNCTION |
|--|-------------------|---------------------------------|
| 1 | \bar{X} | cascade/even-odd-changing input |
| 2, 3, 4, 5, 6, 7, 8, 9, 11, 12, 13, 14, 15, 16, 17, 18 | I_0 to I_{15} | data inputs |
| 10 | GND | ground (0 V) |
| 19 | E/\bar{O} | even/odd parity output |
| 20 | V_{CC} | positive supply voltage |

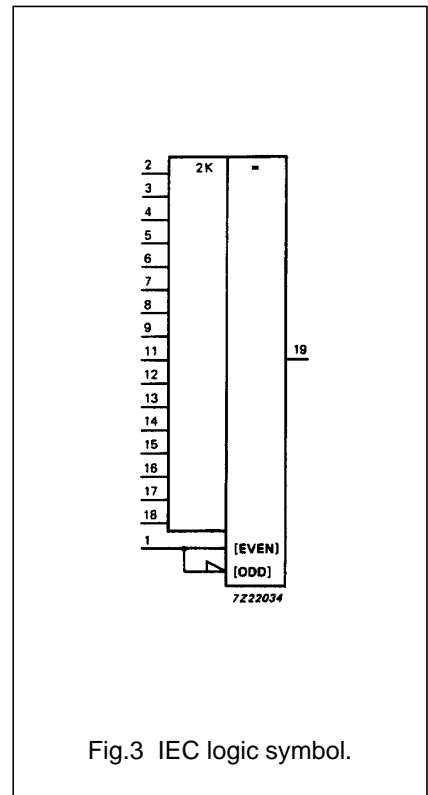
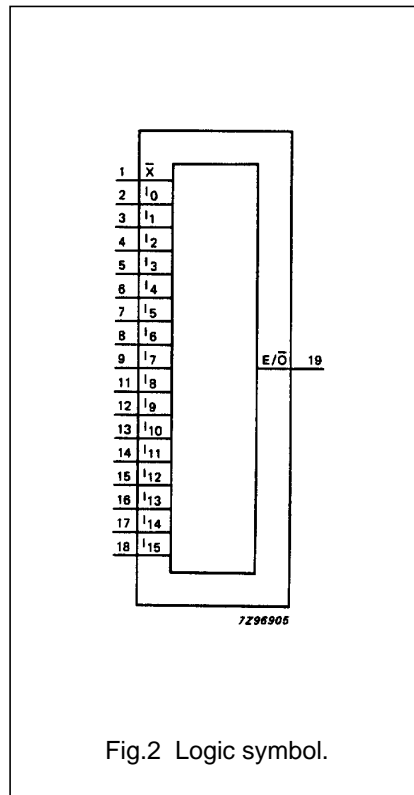
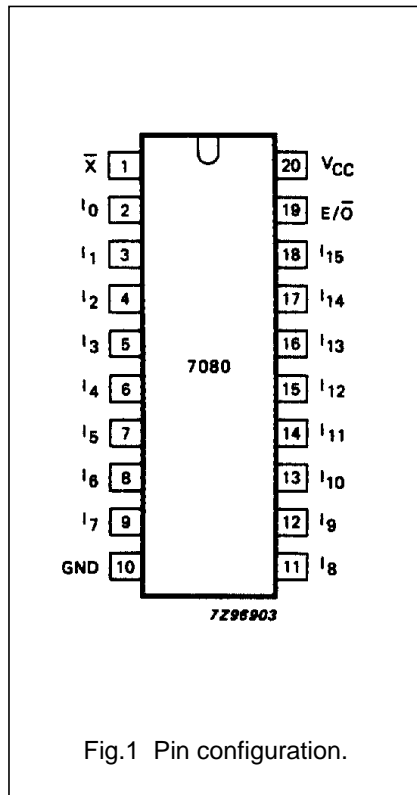

16-bit even/odd parity generator/checker

74HC/HCT7080

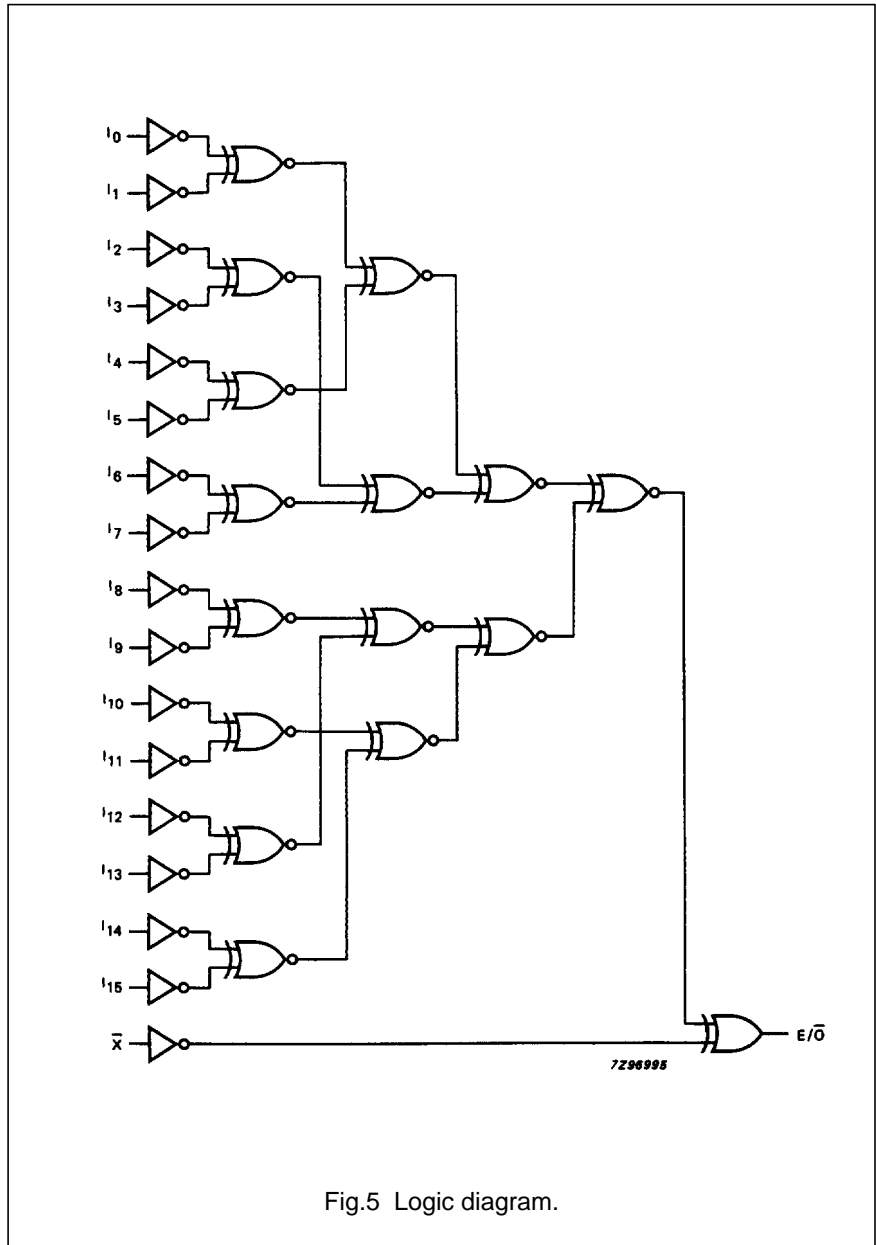
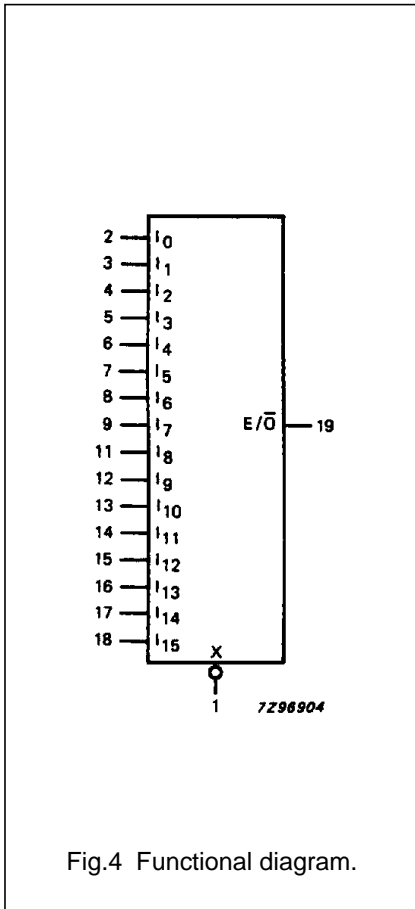

FUNCTION TABLE

| INPUTS | | OUTPUTS |
|-----------------|-----------|-------------|
| I_n | \bar{X} | E/\bar{O} |
| $\Sigma = E$ | H | H |
| | L | L |
| $\Sigma \neq E$ | H | L |
| | L | H |

Notes

- H = HIGH voltage level
L = LOW voltage level
E = even

16-bit even/odd parity generator/checker

74HC/HCT7080

DC CHARACTERISTICS FOR 74HC

For the DC characteristics see *"74HC/HCT/HCU/HCMOS Logic Family Specifications"*.

Output capability: standard

I_{CC} category: MSI

AC CHARACTERISTICS FOR 74HC

GND = 0 V; t_r = t_f = 6 ns; C_L = 50 pF

| SYMBOL | PARAMETER | T _{amb} (°C) | | | | | | | UNIT | TEST CONDITIONS | |
|-------------------------------------|---|-----------------------|----------------|-----------------|------------|-----------------|-------------|-----------------|------|------------------------|--------------|
| | | 74HC | | | | | | | | V _{CC} (V) | WAVEFORMS |
| | | +25 | | | -40 to +85 | | -40 to +125 | | | | |
| | | min. | typ. | max. | min. | max. | min. | max. | | | |
| t _{PHL} / t _{PLH} | propagation delay I _n to E/ \bar{O} | | 91 33 26 | 280 56 48 | | 350 70 60 | | 420 84 71 | ns | 2.0 4.5 6.0 | Fig.7 |
| t _{PHL} / t _{PLH} | propagation delay X to E/ \bar{O} | | 41 15 12 | 150 30 26 | | 190 38 33 | | 225 45 38 | ns | 2.0 4.5 6.0 | Fig.6 |
| t _{THL} / t _{TLH} | output transition time | | 19 7 6 | 75 15 13 | | 95 19 16 | | 110 22 19 | ns | 2.0 4.5 6.0 | Figs 6 and 7 |

16-bit even/odd parity generator/checker

74HC/HCT7080

DC CHARACTERISTICS FOR 74HCT

For the DC characteristics see *"74HC/HCT/HCU/HCMOS Logic Family Specifications"*.

Output capability: standard

I_{CC} category: MSI

Note to HCT types

The value of additional quiescent supply current (ΔI_{CC}) for a unit load of 1 is given in the family specifications.

To determine ΔI_{CC} per input, multiply this value by the unit load coefficient shown in the table below.

| INPUT | UNIT LOAD COEFFICIENT |
|-----------|-----------------------|
| I_n | 1.0 |
| \bar{X} | 1.0 |

AC CHARACTERISTICS FOR 74HCT

GND = 0 V; $t_r = t_f = 6$ ns; $C_L = 50$ pF

| SYMBOL | PARAMETER | T_{amb} (°C) | | | | | | | UNIT | TEST CONDITIONS | |
|-------------------|---|----------------|------|------|------------|------|-------------|------|------|-----------------|--------------|
| | | 74HCT | | | | | | | | V_{CC} (V) | WAVEFORMS |
| | | +25 | | | -40 to +85 | | -40 to +125 | | | | |
| | | min. | typ. | max. | min. | max. | min. | max. | | | |
| t_{PHL}/t_{PLH} | propagation delay I_n to E/\bar{O} | | 37 | 63 | | 79 | | 95 | ns | 4.5 | Fig.7 |
| t_{PHL}/t_{PLH} | propagation delay \bar{X} to E/\bar{O} | | 18 | 32 | | 40 | | 48 | ns | 4.5 | Fig.6 |
| t_{THL}/t_{TLH} | output transition time | | 7 | 15 | | 19 | | 22 | ns | 4.5 | Figs 6 and 7 |

16-bit even/odd parity generator/checker

74HC/HCT7080

AC WAVEFORMS

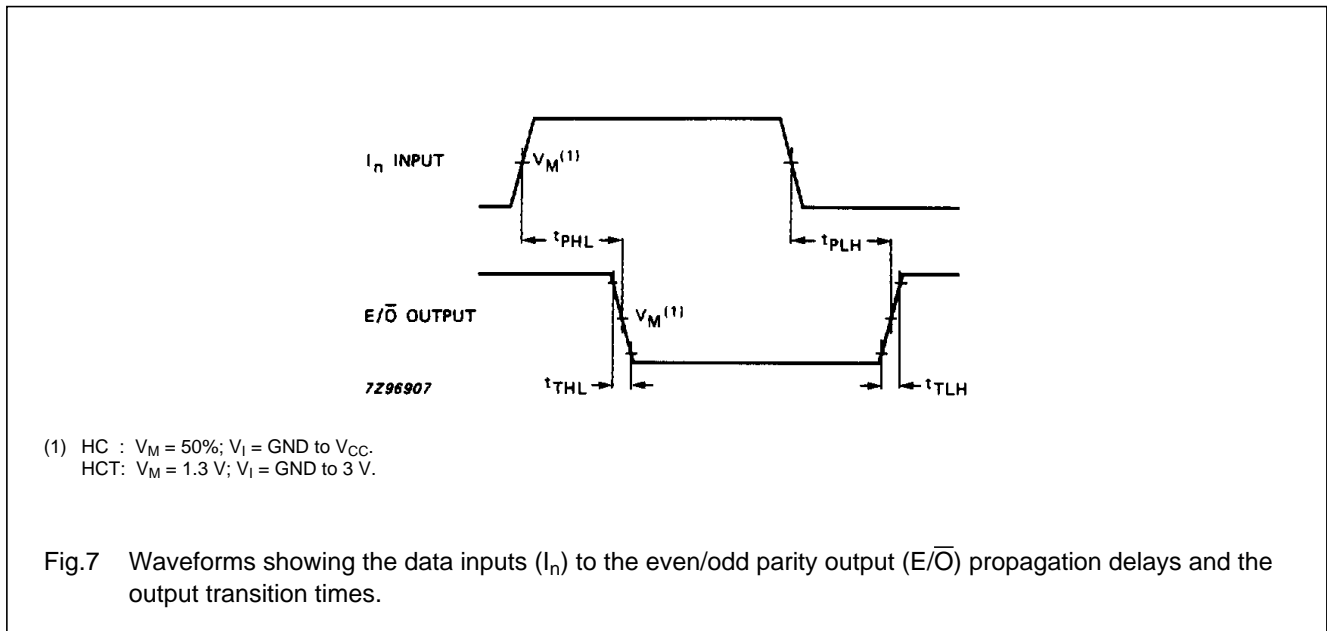
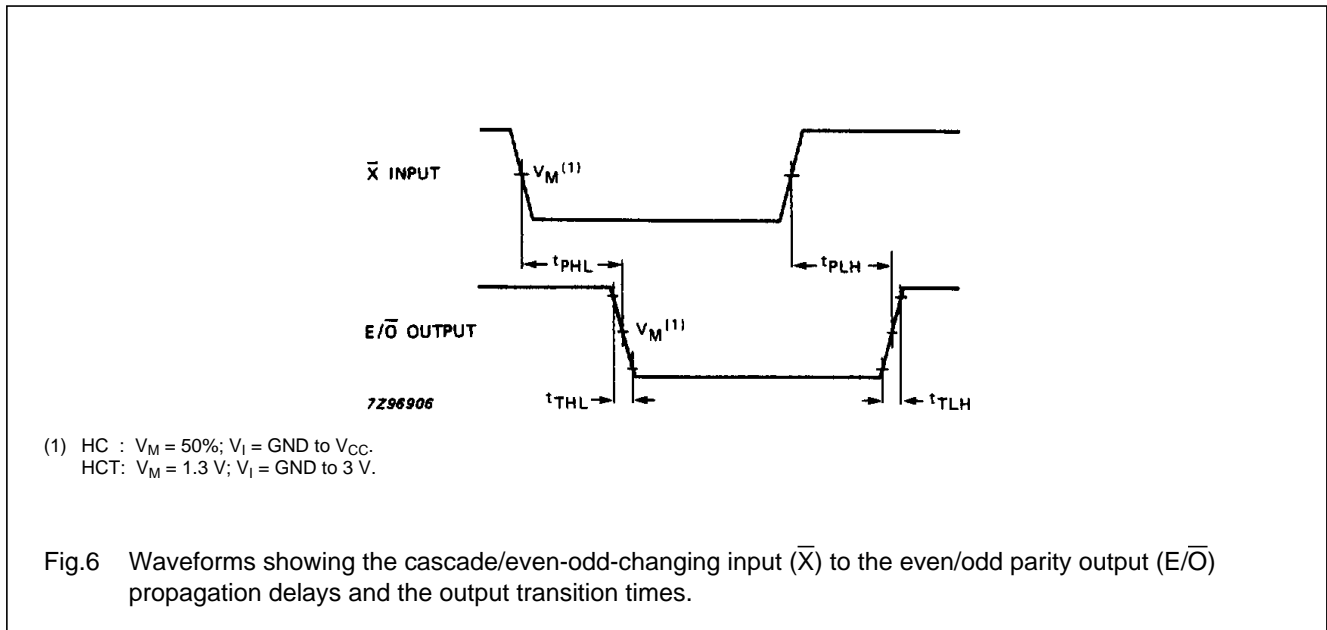

16-bit even/odd parity generator/checker

74HC/HCT7080

TEST CIRCUIT AND WAVEFORMS

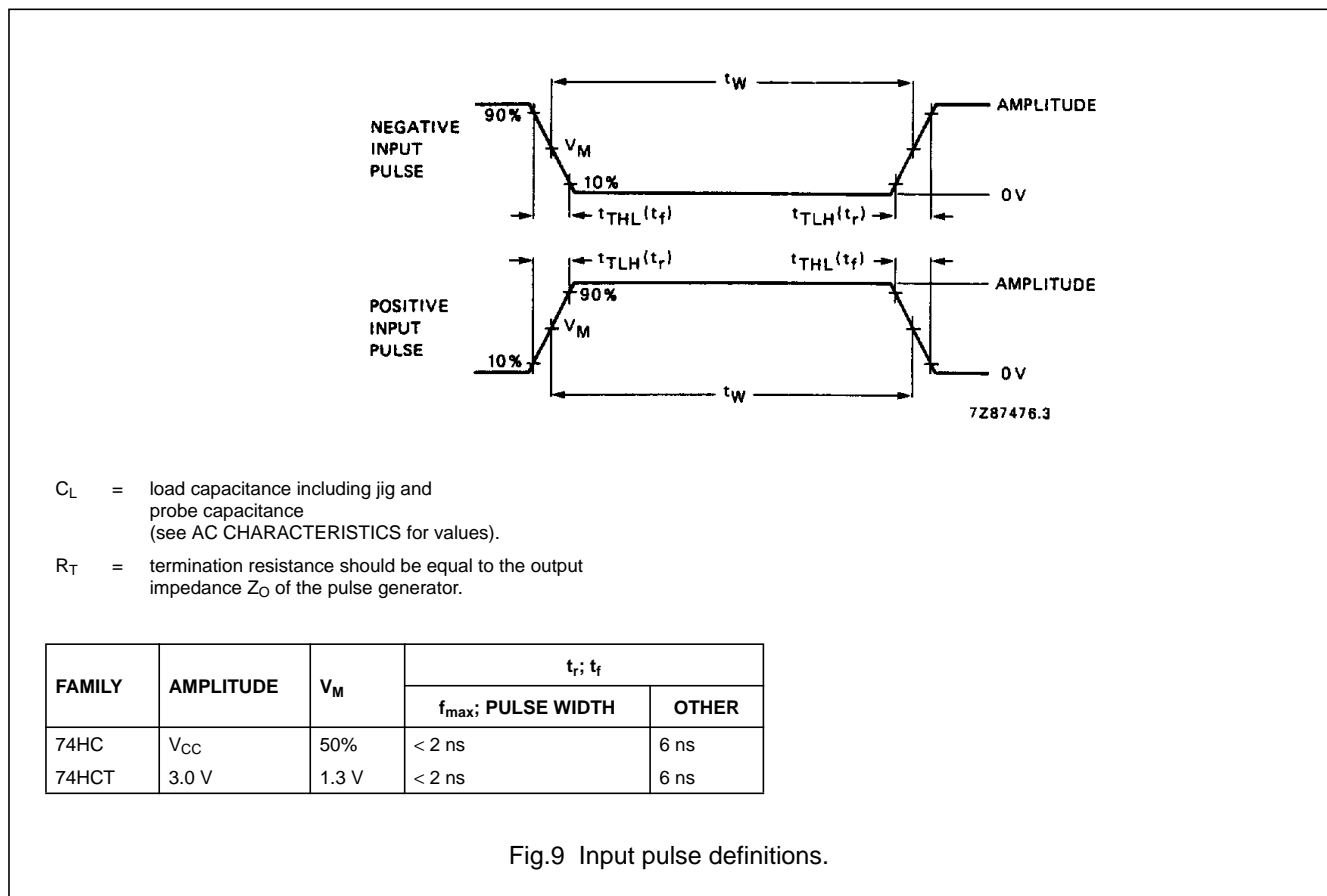
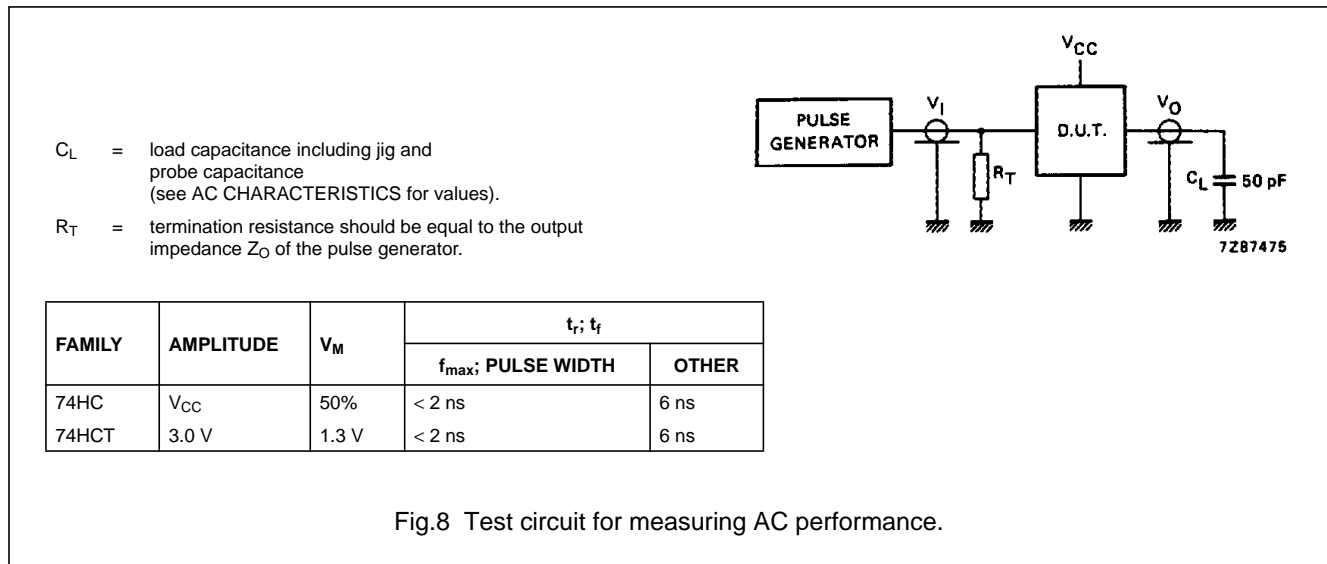

PACKAGE OUTLINES

See "74HC/HCT/HCU/HCMOS Logic Package Outlines".