

# Programmable communications interface (PCI)

# SCN2651

## DESCRIPTION

The Philips Semiconductors SCN2651 PCI is a universal synchronous/asynchronous data communications controller chip designed for microcomputer systems. It interfaces directly to the Philips Semiconductors SCN2650 microprocessor and may be used in a polled or interrupt driven system environment. The SCN2651 accepts programmed instructions from the microprocessor and supports many serial data communication disciplines, synchronous and asynchronous, in the full or half-duplex mode.

The PCI serializes parallel data characters received from the microprocessor for transmission. Simultaneously, it can receive serial data and convert it into parallel data characters for input to the microcomputer.

The SCN2651 contains a baud rate generator which can be programmed to either accept an external clock or to generate internal transmit or receive clocks. Sixteen different baud rates can be selected under program control when operating in the internal clock mode.

The PCI is constructed using Philips Semiconductors n-channel silicon gate depletion load technology and is packaged in a 28-pin DIP.

## FEATURES

- Synchronous operation
  - 5- to 8-bit characters
  - Single or double SYN operation
  - Internal character synchronization
  - Transparent or non-transparent mode
  - Automatic SYN or DLE-SYN insertion
  - SYN or DLE stripping
  - Odd, even, or no parity
  - Local or remote maintenance loopback mode
  - Baud rate: DC to 1Mbps (1X clock)
- Asynchronous operation
  - 5- to 8-bit characters
  - 1, 1-1/2 or 2 stop bits
  - Odd, even, or no parity
  - Parity, overrun and framing error detection
  - Line break detection and generation
  - False start bit detection
  - Automatic serial echo mode
  - Local or remote maintenance loopback mode
  - Baud rate: DC to 1Mbps (1X clock)
    - DC to 62.5kbps (16X clock)
    - DC to 15.625kbps (64X clock)

## PIN CONFIGURATIONS

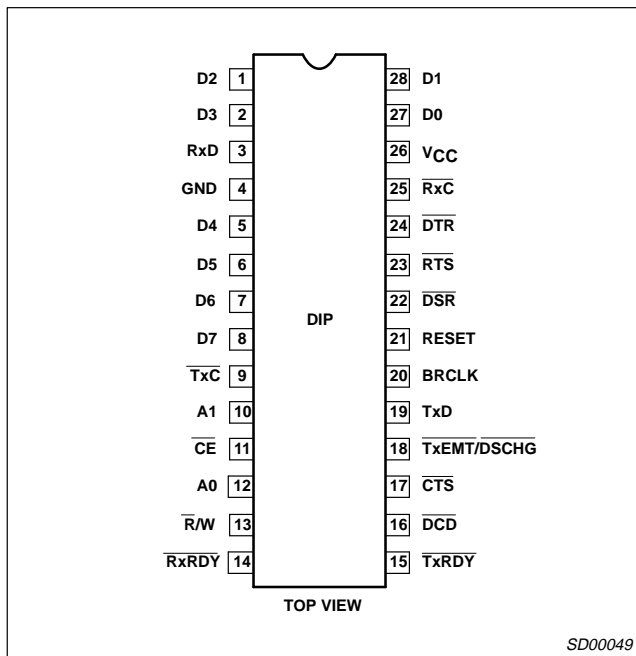

## OTHER FEATURES

- Internal or external baud rate clock
- 16 internal rates – 50 to 19,200 baud
- Double buffered transmitter and receiver
- Full or half duplex operation
- TTL compatible inputs and outputs
- Single 5V power supply
- No system clock required
- 28-pin dual in-line package

## APPLICATIONS

- Intelligent terminals
- Network processors
- Front-end processors
- Remote data concentrators
- Computer to computer links
- Serial peripherals

## ORDERING CODE

PACKAGES	V <sub>CC</sub> = 5V ±5%		DWG #
	Commercial 0°C to +70°C	Industrial -40°C to +85°C	
28-Pin Plastic Dual In-Line Package (DIP)	SCN2651CC1N28	Not available	SOT117-2

# Programmable communications interface (PCI)

SCN2651

## BLOCK DIAGRAM

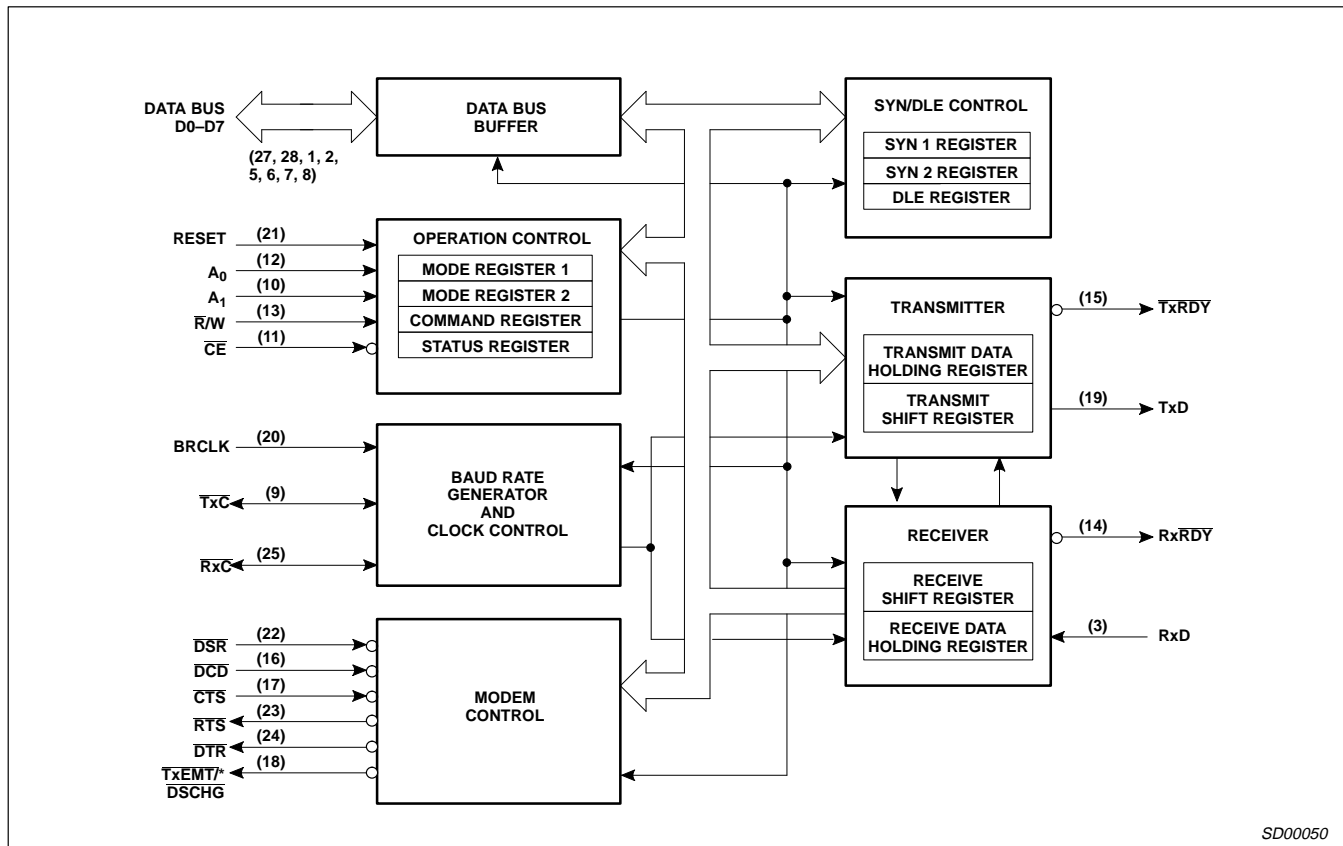

SD00050

## ABSOLUTE MAXIMUM RATINGS<sup>1</sup>

SYMBOL	PARAMETER	RATING	UNIT
T <sub>A</sub>	Operating ambient temperature <sup>2</sup>	Note 4	°C
T <sub>STG</sub>	Storage temperature	-65 to +150	°C
	All voltages with respect to ground <sup>3</sup>	-0.5 to +6.0	V

### NOTES:

- Stresses above those listed under Absolute Maximum Ratings may cause permanent damage to the device. This is a stress rating only and functional operation of the device at these or at any other condition above those indicated in the operation section of this specification is not implied.
- For operating at elevated temperatures, the device must be derated based on +150°C maximum junction temperature.
- This product includes circuitry specifically designed for the protection of its internal devices from the damaging effect of excessive static charge. Nonetheless, it is suggested that conventional precautions be taken to avoid applying any voltages larger than the rated maxima.
- Parameters are valid over operating temperature range unless otherwise specified. See ordering code table for applicable temperature range and operating supply range.

## CAPACITANCE

T<sub>A</sub> = 25°C, V<sub>CC</sub> = 0V

SYMBOL	PARAMETER	TEST CONDITIONS	LIMITS			UNIT
			Min	Typ	Max	
<b>Capacitance</b>						
C <sub>IN</sub>	Input	f <sub>C</sub> = 1MHz Unmeasured pins tied to ground			20	pF
C <sub>OUT</sub>	Output				20	pF
C <sub>I/O</sub>	Input/Output				20	pF

## Programmable communications interface (PCI)

SCN2651

DC ELECTRICAL CHARACTERISTICS<sup>1, 2, 3</sup>

SYMBOL	PARAMETER	TEST CONDITIONS	LIMITS			UNIT
			Min	Typ	Max	
<b>Input voltage</b>						
V <sub>IL</sub> V <sub>IH</sub>	Low High		2.0		0.8	V V
<b>Output voltage</b>						
V <sub>OL</sub> V <sub>OH</sub>	Low High	I <sub>OL</sub> = 1.6mA I <sub>OH</sub> = -100µA	2.4		0.4	V V
I <sub>IL</sub>	Input leakage current	V <sub>IN</sub> = 0 to 5.25V	-10		10	µA
<b>3-State output leakage current</b>						
I <sub>LH</sub> I <sub>LL</sub>	Data bus high Data bus low	V <sub>O</sub> = 4.0V V <sub>O</sub> = 0.45V	-10 -10		10 10	µA µA
I <sub>CC</sub>	Power supply current				150	mA

## NOTES:

- Parameters are valid over operating temperature range unless otherwise specified. See ordering code table for applicable temperature range and operating supply range.
- All voltage measurements are referenced to ground. All time measurements are at the 50% level for inputs (except t<sub>BRH</sub> and t<sub>BRL</sub>) and at 0.8V and 2.0V for outputs. Input levels for testing are 0.45V and 2.4V.
- Typical values are at +25°C, typical supply voltages and typical processing parameters.

AC ELECTRICAL CHARACTERISTICS<sup>1, 2, 3</sup>

SYMBOL	PARAMETER	TEST CONDITIONS	LIMITS			UNIT
			Min	Typ	Max	
<b>Pulse width</b>						
t <sub>RES</sub> t <sub>CE</sub>	Reset Chip enable		1000 300			ns ns
<b>Set-up and hold time</b>						
t <sub>AS</sub> t <sub>AH</sub> t <sub>CS</sub> t <sub>CH</sub> t <sub>DS</sub> t <sub>DH</sub> t <sub>RXS</sub> t <sub>RXH</sub>	Address setup Address hold R/W control setup R/W control hold Data setup for write Data hold for write RX data setup RX data hold		20 20 20 20 225 0 300 350			ns ns ns ns ns ns ns ns
t <sub>DD</sub> t <sub>DF</sub> t <sub>CED</sub>	Data delay time for read Data bus floating time for read CE to CE delay	C <sub>L</sub> = 100pF C <sub>L</sub> = 100pF			250 150	ns ns ns
<b>Input clock frequency</b>						
f <sub>BRG</sub> f <sub>R/T</sub> <sup>6</sup>	Baud rate generator TxC or RxC		1.0 dc	5.0688	5.0738 1.0	MHz MHz
<b>Clock width</b>						
t <sub>BRH</sub> <sup>5</sup> t <sub>BRL</sub> <sup>5</sup> t <sub>R/TH</sub> t <sub>R/TL</sub> <sup>6</sup>	Baud rate high Baud rate low TxC or RxC high TxC or RxC low		70 70 500 500			ns ns ns ns
t <sub>TXD</sub> t <sub>TCS</sub>	TxD delay from falling edge of TxC Skew between TxD changing and falling edge of TxC output <sup>4</sup>	C <sub>L</sub> = 100pF C <sub>L</sub> = 100pF		0	650	ns ns

## NOTES:

- Parameters are valid over operating temperature range unless otherwise specified. See ordering code table for applicable temperature range and operating supply range.
- All voltage measurements are referenced to ground. All time measurements are at the 50% level for inputs (except t<sub>BRH</sub> and t<sub>BRL</sub>) and at 0.8V and 2.0V for outputs. Input levels for testing are 0.45V and 2.4V.
- Typical values are at +25°C, typical supply voltages and typical processing parameters.
- Parameter applies when internal transmitter clock is used.
- Under test conditions of 5.0688MHz, f<sub>BRG</sub>, t<sub>BRH</sub>, and t<sub>BRL</sub> measured at V<sub>IH</sub> and V<sub>IL</sub> respectively.
- t<sub>R/T</sub> and t<sub>R/TL</sub> shown for all modes except local loopback. For local loopback mode f<sub>R/T</sub> = 0.7MHz and t<sub>R/TL</sub> = 700ns min.

# Programmable communications interface (PCI)

SCN2651

## PIN DESCRIPTION

Pin No.	Symbol	Name and Function	Type
27, 28, 1, 2, 5-8	D0 – D7	8-Bit data bus	I/O
21	RESET	Reset	I
12, 10	A <sub>0</sub> –A <sub>1</sub>	Internal register select lines	I
13	R/W	Read or write command	I
11	CE	Chip enable input	I
22	DSR	Data set ready	I
24	DTR	Data terminal ready	O
23	RTS	Request to send	O
17	CTS	Clear to send	I
16	DCD	Data carrier detected	I
18	TxE <sub>MT</sub> /D <sub>SCHG</sub>	Transmitter empty or data set change	O
9	TxC	Transmitter clock	I/O
25	RxC	Receiver clock	I/O
19	TxD	Transmitter data	O
3	RxD	Receiver data	I
15	TxRDY	Transmitter ready	O
14	RxRDY	Receiver ready	O
20	BRCLK	Baud rate generator clock	I
26	V <sub>CC</sub>	+5V supply	I
4	GND	Ground	I

**Table 1. Baud Rate Generator Characteristics**  
Crystal Frequency = 5.0688MHz

Baud Rate	Theoretical Frequency 16X Clock	Actual Frequency 16X Clock	Percent Error	Divisor
50	0.8kHz	0.8kHz	–	6336
75	1.2	1.2	–	4224
110	1.76	1.76	–	2880
134.5	2.152	2.1523	0.016	2355
150	2.4	2.4	–	2112
300	4.8	4.8	–	1056
600	9.6	9.6	–	528
1200	19.2	19.2	–	264
1800	28.8	28.8	–	176
2000	32.0	32.081	0.253	158
2400	38.4	38.4	–	132

**NOTE:** \*Error at 19200 can be reduced to zero by using crystal frequency 4.9152MHz. 16X clock is used in asynchronous mode. In synchronous mode, clock multiplier is 1X.

## BLOCK DIAGRAM

The PCI consists of six major sections. These are the transmitter, receiver, timing, operation control, modem control and SYN/DLE control. These sections communicate with each other via an internal data bus and an internal control bus. The internal data bus interfaces to the microprocessor data bus via a data bus buffer.

## Operation Control

This functional block stores configuration and operation commands from the CPU and generates appropriate signals to various internal sections to control the overall device operation. It contains read and write circuits to permit communications with the microprocessor via

the data bus and contains mode registers 1 and 2, the command register, and the status register. Details of register addressing and protocol are presented in the PCI programming section of this data sheet.

## Timing

The PCI contains a baud rate generator (BRG) which is programmable to accept external transmit or receive clocks or to divide an external clock to perform data communications. The unit can generate 16 commonly used baud rates, any one of which can be selected for full-duplex operation. See Table 1.

## Receiver

The receiver accepts serial data on the RxD pin, converts this serial input to parallel format, checks for bits or characters that are unique to the communication technique and sends an “assembled” character to the CPU.

## Transmitter

The transmitter accepts parallel data from the CPU, converts it to a serial bit stream, inserts the appropriate characters or bits (based on the communication technique) and outputs a composite serial stream of data on the TxD output pin.

## Modem Control

The modem control section provides interfacing for three input signals and three output signals used for “handshaking” and status indication between the CPU and a modem.

## SYN/DLE Control

This section contains control circuitry and three 8-bit registers storing the SYN1, SYN2, and DLE characters provided by the CPU. These registers are used in the synchronous mode of operation to provide the characters required for synchronization, idle fill and data transparency.

# Programmable communications interface (PCI)

# SCN2651

## INTERFACE SIGNALS

The PCI interface signals can be grouped into two types: the CPU-related signals (shown in Table 2), which interface the SCN2651 to the microprocessor system, and the device-related signals (shown in Table 3), which are used to interface to the communications device or system.

## OPERATION

The functional operation of the SCN2651 is programmed by a set of control words supplied by the CPU. These control words specify items such as synchronous or asynchronous mode, baud rate, number of bits per character, etc. The programming procedure is described in the PCI programming section of the data sheet.

After programming, the PCI is ready to perform the desired communications functions. The receiver performs serial to parallel conversion of data received from a modem or equivalent device. The transmitter converts parallel data received from the CPU to a serial bit stream. These actions are accomplished within the framework specified by the control words.

### Receiver

The SCN2651 is conditioned to receive data when the  $\overline{\text{DCD}}$  input is low and the RxEN bit in the command register is true. In the asynchronous mode, the receiver looks for a high to low transition of the start bit on the RxD input line. If a transition is detected, the state of the RxD line is sampled again after a delay of one-half of a bit-time. If RxD is now high, the search for a valid start bit is begun again. If RxD is still low, a valid start bit is assumed and the receiver continues to sample the input line at one bit time intervals until the proper number of data bits, the parity bit, and one stop bit(s) have

been assembled. The data is then transferred to the receive data holding register, the RxRDY bit in the status register is set, and the  $\overline{\text{RxRDY}}$  output is asserted. If the character length is less than 8 bits, the high order unused bits in the holding register are set to zero. The parity error, framing error, and overrun error status bits are strobed into the status register on the positive going edge of  $\overline{\text{RxC}}$  corresponding to the received character boundary. If a break condition is detected (RxD is low for the entire character as well as the stop bit[s]), only one character consisting of all zeros (with the FE status bit set) will be transferred to the holding register. The RxD input must return to a high condition before a search for the next start bit begins.

When the PCI is initialized into the synchronous mode, the receiver first enters the hunt mode on a 0 to 1 transition of RxEN (CR2). In this mode, as data is shifted into the receiver shift register a bit at a time, the contents of the register are compared to the contents of the SYN1 register. If the two are not equal, the next bit is shifted in and the comparison is repeated. When the two registers match, the hunt mode is terminated and character assembly mode begins. If single SYN operation is programmed, the SYN detect status bit is set. If double SYN operation is programmed, the first character assembled after SYN1 must be SYN2 in order for the SYN detect bit to be set. Otherwise, the PCI returns to the hunt mode. (Note that the sequence SYN1–SYN1–SYN2 will not achieve synchronization.) When synchronization has been achieved, the PCI continues to assemble characters and transfer them to the holding register, setting the RxRDY status bit and asserting the  $\overline{\text{RxRDY}}$  output each time a character is transferred. The PE and OE status bits are set as appropriate. Further receipt of the appropriate SYN sequence sets the SYN detect status bit. If the SYN stripping mode is

**Table 2. CPU-Related Signals**

PIN NAME	PIN NO.	INPUT/OUTPUT	FUNCTION
V <sub>CC</sub>	26	I	+5V supply input
GND	4	I	Ground
RESET	21	I	A high on this input performs a master reset on the SCN2651. This signal asynchronously terminates any device activity and clears the mode, command and status registers. The device assumes the idle state and remains there until initialized with the appropriate control words.
A <sub>1</sub> – A <sub>0</sub>	10, 12	I	Address lines used to select internal PCI registers.
$\overline{\text{R/W}}$	13	I	Read command when low, write command when high.
$\overline{\text{CE}}$	11	I	Chip enable command. When low, indicates that control and data lines to the PCI are valid and that the operation specified by the $\overline{\text{R/W}}$ , A <sub>1</sub> and A <sub>0</sub> inputs should be performed. When high, places the D <sub>0</sub> –D <sub>7</sub> lines in the 3-State condition.
D <sub>7</sub> – D <sub>0</sub>	8, 7, 6, 5, 2, 1, 28, 27	I/O	8-bit, three-state data bus used to transfer commands, data and status between PCI and the CPU. D <sub>0</sub> is the least significant bit, D <sub>7</sub> the most significant bit.
$\overline{\text{TxRDY}}$	15	O	This output is the complement of status register bit SR0. When low, it indicates that the transmit data holding register (THR) is ready to accept a data character from the CPU. It goes high when the data character is loaded. This output is valid only when the transmitter is enabled. It is an open drain output which can be used as an interrupt to the CPU.
$\overline{\text{RxRDY}}$	14	O	This output is the complement of status register bit SR1. When low, it indicates that the receive data holding register (RHR) has a character ready for input to the CPU. It goes high when the RHR is read by the CPU, and also when the receiver is disabled. It is an open drain output which can be used as an interrupt to the CPU.
$\overline{\text{TxEMT/DS}}/\text{CHG}$	18	O	This output is the complement of status register bit SR2. When low, it indicates that the transmitter has completed serialization of the last character loaded by the CPU, or that a change of state of the DSR or $\overline{\text{DCD}}$ inputs has occurred. This output goes high when the status register is read by the CPU, if the TxEMT condition does not exist. Otherwise, the THR must be loaded by the CPU for this line to go high. It is an open drain output which can be used as an interrupt to the CPU.

## Programmable communications interface (PCI)

SCN2651

Table 3. Device-Related Signals

PIN NAME	PIN NO.	INPUT/O UTPUT	FUNCTION
BRCLK	20	I	5.0688MHz clock input to the internal baud rate generator. Not required if external receiver and transmitter clocks are used.
$\overline{\text{RxC}}$	25	I/O	Receiver clock. If external receiver clock is programmed, this input controls the rate at which the character is to be received. Its frequency is 1X, 16X or 64X the baud rate, as programmed by mode register 1. Data are sampled on the rising edge of the clock. If internal receiver clock is programmed, this pin becomes an output at 1X the programmed baud rate.*
$\overline{\text{TxC}}$	9	I/O	Transmitter clock. If external transmitter clock is programmed, this input controls the rate at which the character is transmitted. Its frequency is 1X, 16X or 64X the baud rate, as programmed by mode register 1. The transmitted data changes on the falling edge of the clock. If internal transmitter clock is programmed, the pin becomes an output at 1X the programmed baud rate.*
RxD	3	I	Serial data input to the receiver. "Mark" is high, "Space" is low.
TxD	19	O	Serial data output from the transmitter. "Mark" is high, "space" is low. Held in mark condition when the transmitter is disabled.
$\overline{\text{DSR}}$	22	I	General purpose input which can be used for data set ready or ring indicator condition. Its complement appears as status register bit SR7. Causes a low output on TxEMT/DSCHG when its state changes.
$\overline{\text{DCD}}$	16	I	Data carrier detect input. Must be low in order for the receiver to operate. Its complement appears as status register bit SR6. Causes a low output on TxEMT/DSCHG when its state changes.
$\overline{\text{CTS}}$	17	I	Clear to send input. Must be low in order for the transmitter to operate. If it goes high during transmission, the character in the transmit shift register will be transmitted before termination.
$\overline{\text{DTR}}$	24	O	General purpose output which is the complement of command register bit CR1. Normally used to indicate data terminal ready.
RTS	23	O	General purpose output which is the complement of command register bit CR5. Normally used to indicate request to send.

**NOTE:** \*RxC and TxC outputs have short circuit protection max.  $C_L = 100\text{pF}$

commanded, SYN characters are not transferred to the Holding Register. Note that the SYN characters used to establish initial synchronization are not transferred to the holding register in any case.

### Transmitter

The PCI is conditioned to transmit data when the  $\overline{\text{CTS}}$  input is Low and the TxEN command register bit is set. The SCN2651 indicates to the CPU that it can accept a character for transmission by setting the TxRDY status bit and asserting the  $\overline{\text{TxRDY}}$  output. When the CPU writes a character into the transmit data holding register, these conditions are negated. Data is transferred from the holding register to the transmit shift register when it is idle or has completed transmission of the previous character. The TxRDY conditions are then asserted again. Thus, one full character time of buffering is provided.

In the asynchronous mode, the transmitter automatically sends a start bit followed by the programmed number of data bits, the least significant bit being sent first. It then appends an optional odd or even parity bit and the programmed number of stop bits. If, following transmission of the data bits, a new character is not available in the transmit holding register, the TxD output remains in the marking (high) condition and the TxEMT/DSCHG output and its corresponding status bit are asserted. Transmission resumes when the CPU loads a new character into the holding register. The transmitter can be forced to output a continuous low (BREAK) condition by setting the send break command bit high.

In the synchronous mode, when the SCN2651 is initially conditioned to transmit, the TxD output remains high and the TxRDY condition is asserted until the first character to be transmitted (usually a SYN character) is loaded by the CPU. Subsequent to this, a continuous stream of characters is transmitted. No extra bits (other than parity, if commanded) are generated by the PCI unless the CPU fails to

send a new character to the PCI by the time the transmitter has completed sending the previous character.

Since synchronous communication does not allow gaps between characters, the PCI asserts TxEMT and automatically "fills" the gap by transmitting SYN1s, SYN1-SYN2 doublets, or DLE-SYN1 doublets, depending on the state of MR16 and MR17. Normal transmission of the message resumes when a new character is available in the transmit data holding register. If the send DLE bit in the command register is true, the DLE character is automatically transmitted prior to transmission of the message character in the THR.

### PCI PROGRAMMING

Prior to initiating data communications, the SCN2651 operational mode must be programmed by performing write operations to the mode and command registers. In addition, if synchronous operation is programmed, the appropriate SYN/DLE registers must be loaded. The PCI can be reconfigured at any time during program execution. However, if the change has an effect on the reception of a character the receiver should be disabled. Alternatively if the change is made 1 1/2 RxC periods after RxRDY goes active it will affect the next character assembly. A flowchart of the initialization process appears in Figure 1.

The internal registers of the PCI are accessed by applying specific signals to the  $\overline{\text{CE}}$ ,  $\overline{\text{R/W}}$ ,  $A_1$  and  $A_0$  inputs. The conditions necessary to address each register are shown in Table 4.

The SYN1, SYN2, and DLE registers are accessed by performing write operations with the conditions  $A_1 = 0$ ,  $A_0 = 1$ , and  $\overline{\text{R/W}} = 1$ . The first operation loads the SYN1 register. The next loads the SYN2 register, and the third loads the DLE register. Reading or loading the mode registers is done in a similar manner. The first write (or read) operation addresses mode register 1, and a subsequent operation addresses mode register 2. If more than the



# Programmable communications interface (PCI)

# SCN2651

required number of accesses are made, the internal sequencer recycles to point at the first register. The pointers are reset to SYN1 register and mode register 1 by a RESET input or by performing a "read command register" operation, but are unaffected by any other read or write operation.

The SCN2651 register formats are summarized in Tables 5, 6, 7 and 8. Mode registers 1 and 2 define the general operational characteristics of the PCI, while the command register controls the operation within this basic framework. The PCI indicates its status in the status register. These registers are cleared when a RESET input is applied.

### Mode Register 1 (MR1)

Table 5 illustrates mode register 1. Bits MR11 and MR10 select the communication format and baud rate multiplier. 00 specifies synchronous mode and 1X multiplier. 1X, 16X, and 64X multipliers are programmable for asynchronous format. However, the multiplier in asynchronous format applies only if the external clock input option is selected by MR24 or MR25.

MR13 and MR12 select a character length of 5, 6, 7, or 8 bits. The character length does not include the parity bit, if programmed, and does not include the start and stop bits in asynchronous mode.

MR14 controls parity generation. If enabled, a parity bit is added to the transmitted character and the receiver performs a parity check on incoming data. MR15 selects odd or even parity when parity is enabled by MR14.

In asynchronous mode, MR17 and MR16 select character framing of 1, 1.5, or 2 stop bits. (If 1X baud rate is programmed, 1.5 stop bits default to 1 stop bit on transmit.) In synchronous mode, MR17 controls the number of SYN characters used to establish synchronization and for character fill when the transmitter is idle. SYN1 alone is used if MR17 = 1, and SYN1–SYN2 is used when MR17 = 0. If the transparent mode is specified by MR16, DLE–SYN1 is used for character fill and SYN detect, but the normal synchronization sequence is used. Also DLE stripping and DLE detect (with MR14 = 0) are enabled.

### Mode Register 2 (MR2)

Table 6 illustrates mode register 2. MR23, MR22, MR21, and MR20 control the frequency of the internal baud rate generator (BRG). Sixteen rates are selectable. When driven by a 5.0688MHz input at the BRCLK input (Pin 20), the BRG output has zero error except at 134.5 2000, and 19,200 baud, which have errors of +0.016%, +0.235%, and +3.125% respectively.

**Table 4. SCN2651 Register Addressing**

CE	A <sub>1</sub>	A <sub>0</sub>	R/W	FUNCTION
1	X	X	X	3-State data bus
0	0	0	0	Read receive holding register
0	0	0	1	Write transmit holding register
0	0	1	0	Read status register
0	0	1	1	Write SYN1/SYN2/DLE registers
0	1	0	0	Read mode registers 1/2
0	1	0	1	Write mode registers 1/2
0	1	1	0	Read command register

0	1	1	1	Write command register
<b>NOTE:</b> See AC Characteristics section for timing requirements.				

MR25 and MR24 select either the BRG or the external inputs Tx̄C and Rx̄C as the clock source for the transmitter and receiver, respectively. If the BRG clock is selected, the baud rate factor in asynchronous mode is 16X regardless of the factor selected by MR11 and MR10. In addition, the corresponding clock pin provides an output at 1X the baud rate.

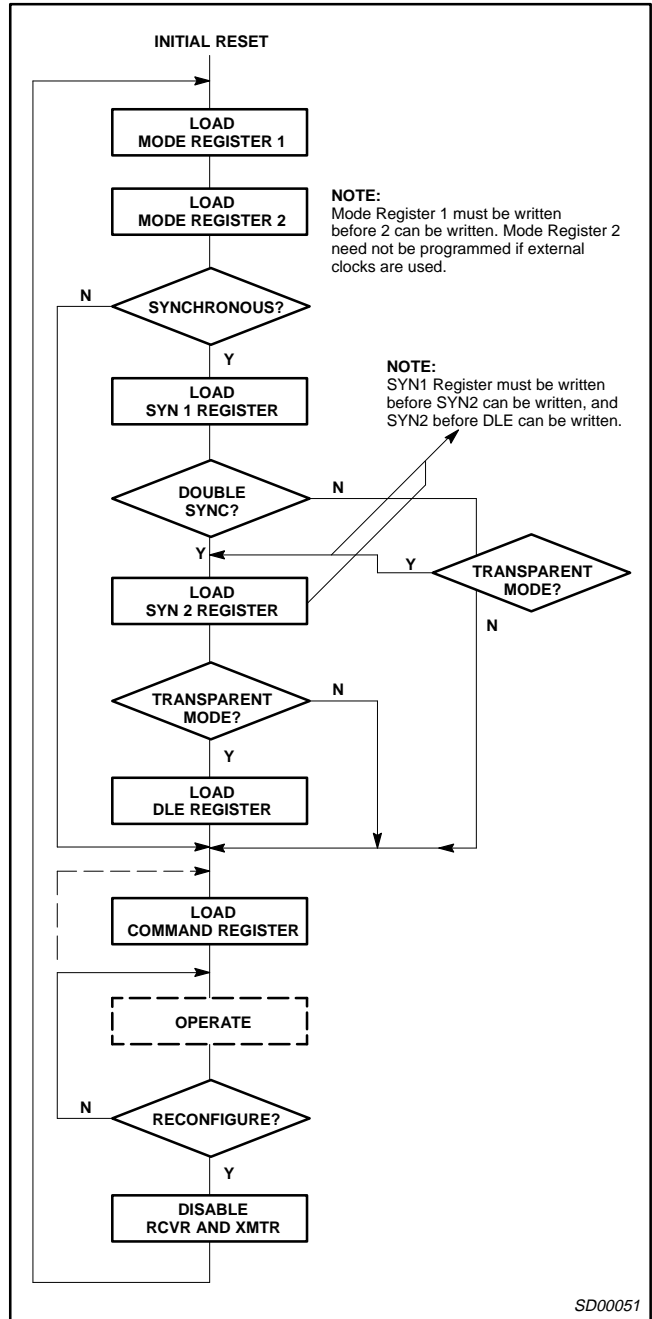

**Figure 1. SCN2651 Initialization Flowchart**

# Programmable communications interface (PCI)

# SCN2651

**Table 5. Mode Register 1 (MR1)**

MR17	MR16	MR15	MR14	MR13	MR12	MR11	MR10
		<b>Parity Type</b>	<b>Parity Control</b>	<b>Character Length</b>		<b>Mode and Baud Rate Factor</b>	
<b>Async: Stop bit length</b> 00 = Invalid 01 = 1 Stop bit 10 = 1 1/2 Stop bits 11 = 2 Stop bits		0 = Odd 1 = Even	0 = Disabled 1 = Enabled	00 = 5 Bits 01 = 6 Bits 10 = 7 Bits 11 = 8 Bits		00 = Synchronous 1X rate 01 = Asynchronous 1X rate 10 = Asynchronous 16X rate 11 = Asynchronous 64X rate	
<b>Sync: Number of SYN char</b>  0 = Double SYN 1 = Single SYN	<b>Sync: Transparency control</b>  0 = Normal 1 = Transparent						

**NOTE:**

Baud rate factor in asynchronous applies only if external clock is selected. Factor is 16X if internal clock is selected. Mode must be selected (MR11, MR10) in any case.

**Table 6. Mode Register 2 (MR2)**

MR27	MR26	MR25	MR24	MR23	MR22	MR21	MR20
Not used		<b>Transmitter Clock</b>	<b>Receiver Clock</b>	<b>Baud Rate Selection</b>			
		0 = External 1 = Internal	0 = External 1 = Internal	0000 = 50 Baud 0001 = 75 0010 = 110 0011 = 134.5 0100 = 150 0101 = 300 0110 = 600 0111 = 1200		1000 = 1800 Baud 1001 = 2000 1010 = 2400 1011 = 3600 1100 = 4800 1101 = 7200 1110 = 9600 1111 = 19,200	

**Table 7. Command Register (CR)**

CR7	CR6	CR5	CR4	CR3	CR2	CR1	CR0
<b>Operating Mode</b>		<b>Request to Send</b>	<b>Reset Error</b>		<b>Receive Control (RxEN)</b>	<b>Data Terminal Ready</b>	<b>Transmit Control (TxEN)</b>
00 = Normal operation 01 = Async: automatic echo mode Sync: SYN and/or DLE stripping mode 10 = Local Loopback 11 = Remote Loopback		0 = Force RTS output high 1 = Force RTS output low	0 = Normal 1 = Reset error flag in status reg (FE, OE, PE/DLE DETECT)	<b>Async: Force Break</b> 0 = Normal 1 = Force break  <b>Sync Send DLE</b> 0 = Normal 1 = Send DLE	0 = Disable 1 = Enable	0 = Force DTR output high 1 = Force DTR output low	0 = Disable 1 = Enable

**Command Register (CR)**

Table 7 illustrates the command register. Bits CR0 (TxEN) and CR2 (RxEN) enable or disable the transmitter and receiver respectively. A 0 to 1 transition of CR2 forces start bit search (async mode) or hunt mode (sync mode) on the second  $\overline{RxC}$  rising edge. Disabling the receiver causes  $\overline{RxRDY}$  to go high (inactive). If the transmitter is disabled, it will complete the transmission of the character in the transmit shift register (if any) prior to terminating operation. The TxD output will then remain in the marking state (high) while  $\overline{TxRDY}$  and  $\overline{TxEMT}$  will go high (inactive). If the receiver is disabled, it will terminate operation immediately. Any character being assembled will be neglected.

Bits CR1 (DTR) and CR5 (RTS) control the  $\overline{DTR}$  and RTS outputs. Data at the outputs is the logical complement of the register data.

In asynchronous mode, setting CR3 will force and hold the TxD output low (spacing condition) at the end of the current transmitted character. Normal operation resumes when CR3 is cleared. The TxD line will go high for at least one bit time before beginning transmission of the next character in the transmit data holding register. In synchronous mode, setting CR3 causes the transmission of the DLE register contents prior to sending the character in the transmit data holding register. CR3 should be reset in response to the next  $\overline{TxRDY}$ .



## Programmable communications interface (PCI)

## SCN2651

Table 8. Status Register (SR)

SR7	SR6	SR5	SR4	SR3	SR2	SR1	SR0
Data Set Ready	Data Carrier Detect	FE/SYN Detect	Overrun	PE/DLE Detect	TxE $\overline{M}$ T/ $\overline{D}$ SCHG	RxRDY	TxRDY
0 = $\overline{D}$ SR input is high 1 = $\overline{D}$ SR input is low	0 = DCD input is high 1 = DCD input is low	<b>Async:</b> 0 = Normal 1 = Framing ERROR <b>Sync:</b> 0 = Normal 1 = SYN char detected	0 = Normal 1 = Overrun error	<b>Async:</b> 0 = Normal 1 = Parity error <b>Sync:</b> 0 = Normal 1 = Parity error or DLE char received	0 = Normal 1 = Change in $\overline{D}$ SR or $\overline{D}$ CD, or transmit shift register is empty	0 = Receive holding register empty 1 = Receive holding register has data	0 = Transmit holding register busy 1 = Transmit holding register empty

Setting CR4 causes the error flags in the status register (SR3, SR4, and SR5) to be cleared. This is a one time command. There is no internal latch for this bit.

The PCI can operate in one of four submodes within each major mode (synchronous or asynchronous). The operational submode is determined by CR7 and CR6. CR7 – CR6 = 00 is the normal mode, with the transmitter and receiver operating independently in accordance with the mode and status register instructions.

In asynchronous mode, CR7 – CR6 = 01 places the PCI in the automatic echo mode. Clocked, regenerated received data are automatically directed to the Tx $\overline{D}$  line while normal receiver operation continues. The receiver must be enabled (CR2 = 1), but the transmitter need not be enabled. CPU to receiver communications continues normally, but the CPU to transmitter link is disabled. Only the first character of a break condition is echoed. The Tx $\overline{D}$  output will go high until the next valid start is detected.

The following conditions are true while in automatic echo mode:

1. Data assembled by the receiver are automatically placed in the transmit holding register and retransmitted by the transmitter on the Tx $\overline{D}$  output.
2. The transmitter is clocked by the receive clock.
3.  $\overline{TxRDY}$  output = 1.
4. The  $\overline{TxE\overline{M}T/D\overline{S}CHG}$  pin will reflect only the data set change condition.
5. The TxEN command (CR0) is ignored.

In synchronous mode, CR7 – CR6 = 01 places the PCI in the automatic SYN/DLE stripping mode. The exact action taken depends on the setting of bits MR17 and MR16:

1. In the non-transparent, single SYN mode (MR17 – MR16 = 10), characters in the data stream matching SYN1 are not transferred to the receive data holding register (RHR).
2. In the non-transparent, double SYN mode (MR17 – MR16 = 00), characters in the data stream matching SYN1, or SYN2 if immediately preceded by SYN1, are not transferred the RHR. However, only the first SYN1 of an SYN1 – SYN1 pair is stripped.
3. In transparent mode (MR16 = 1), character in the data stream matching DLE, or SYN1 if immediately preceded by DLE, are not transferred to the RHR. However, only the first DLE of a DLE – DLE pair is stripped.

Note that automatic stripping mode does not affect the setting of the DLE detect and SYN detect status bits (SR3 and SR5).

Two diagnostic submodes can also be configured. In local loopback mode (CR7 – CR6 = 10), the following loops are connected internally:

1. The transmitter output is connected to the receiver input.
2.  $\overline{DTR}$  is connected to  $\overline{DCD}$  and  $\overline{RTS}$  is connected to  $\overline{CTS}$ .
3. The receiver is clocked by the transmit clock.
4. The  $\overline{DTR}$ ,  $\overline{RTS}$  and  $\overline{TxD}$  outputs are held high.
5. The  $\overline{CTS}$ ,  $\overline{DCD}$ ,  $\overline{DSR}$  and Rx $\overline{D}$  inputs are ignored.

Additional requirements to operate in the local loopback mode are that CR0 (TxEN), CR1 (DTR), and CR5 (RTS) must be set to 1. CR2 (RxEN) is ignored by the PCI.

The second diagnostic mode is the remote loopback mode (CR7 – CR6 = 11). In this mode:

1. Data assembled by the receiver are automatically placed in the transmit holding register and retransmitted by the transmitter on the Tx $\overline{D}$  output.
2. The transmitter is clocked by the receive clock.
3. No data is sent to the local CPU, but the error status conditions (PE, OE, FE) are set.
4. The  $\overline{RxRDY}$ ,  $\overline{TxRDY}$ , and  $\overline{TxE\overline{M}T/D\overline{S}CHG}$  outputs are held high.
5. CR0 (TxEN) is ignored.
6. All other signals operate normally.

### Status Register

The data contained in the status register (as shown in Table 8) indicate receiver and transmitter conditions and modem/data set status.

SR0 is the transmitter ready (TxRDY) status bit. It, and its corresponding output, are valid only when the transmitter is enabled. If equal to 0, it indicates that the transmit data holding register has been loaded by the CPU and the data has not been transferred to the transmit shift register. If set equal to 1, it indicates that the Holding Register is ready to accept data from the CPU. This bit is initially set when the transmitter is enabled by CR0, unless a character has previously been loaded into the holding register. It is not set when the automatic echo or remote loopback modes are programmed. When this bit is set, the  $\overline{TxRDY}$  output pin is low. In the automatic echo and remote loopback modes, the output is held high.

SR1, the receiver ready (RxRDY) status bit, indicates the condition of the receive data holding register. If set, it indicates that a

## Programmable communications interface (PCI)

## SCN2651

character has been loaded into the holding register from the receive shift register and is ready to be read by the CPU. If equal to zero, there is no new character in the holding register. This bit is cleared when the CPU reads the receive data holding register or when the receiver is disabled by CR2. When set, the RxRDY output is low.

The TxEMT/DSCHG bit, SR2, when set, indicates either a change of state of the  $\overline{DSR}$  or  $\overline{DCD}$  inputs or that the transmit shift register has completed transmission of a character and no new character has been loaded into the transmit data holding register. Note that in synchronous mode this bit will be set even though the appropriate "fill" character is transmitted. TxEMT will not go active until at least one character has been transmitted. It is cleared by loading the transmit data holding register. The DSCHG condition is enabled when TxEN = 1 or RxEN = 1. If the status register is read twice and SR2 = 1 while SR6 and SR7 remain unchanged, then a TxEMT condition exists. It is cleared when the status register is read by the CPU. When SR2 is set, the TxEMT/DSCHG output is low.

SR3, when set, indicates a received parity error when parity is enabled by MR14. In synchronous transparent mode (MR16 = 1), with parity disabled, it indicates that a character matching the DLE register has been received. However, only the first DLE of two successive DLEs will set SR3. This bit is cleared when the receiver is disabled and by the reset error command, CR4.

The overrun error status bit, SR4, indicates that the previous character loaded into the receive holding register was not read by the CPU at the time a new received character was transferred into it. This bit is cleared when the receiver is disabled and by the reset error command, CR4.

In asynchronous mode, bit SR5 signifies that the received character was not framed by the programmed number of stop bits. (If 1.5 stop bits are programmed, only the first stop bit is checked.) If RHR = 0 when SR5 = 1, a break condition is present. In synchronous non-transparent mode (MR16 = 0), it indicates receipt of the SYN1 character in single SYN mode or the SYN1 – SYN2 pair in double SYN mode. In synchronous transparent mode (MR16 = 1), this bit is set upon detection of the initial synchronizing characters (SYN1 or SYN1 – SYN2) and, after synchronization has been achieved, when a DLE–SYN1 pair is received. The bit is reset when the receiver is disabled, when the reset error command is given in asynchronous mode, and when the status register is read by the CPU in the synchronous mode.

SR6 and SR7 reflect the conditions of the  $\overline{DCD}$  and  $\overline{DSR}$  inputs respectively. A low input sets its corresponding status bit and a high input clears it.

# Programmable communications interface (PCI)

# SCN2651

## TIMING DIAGRAMS

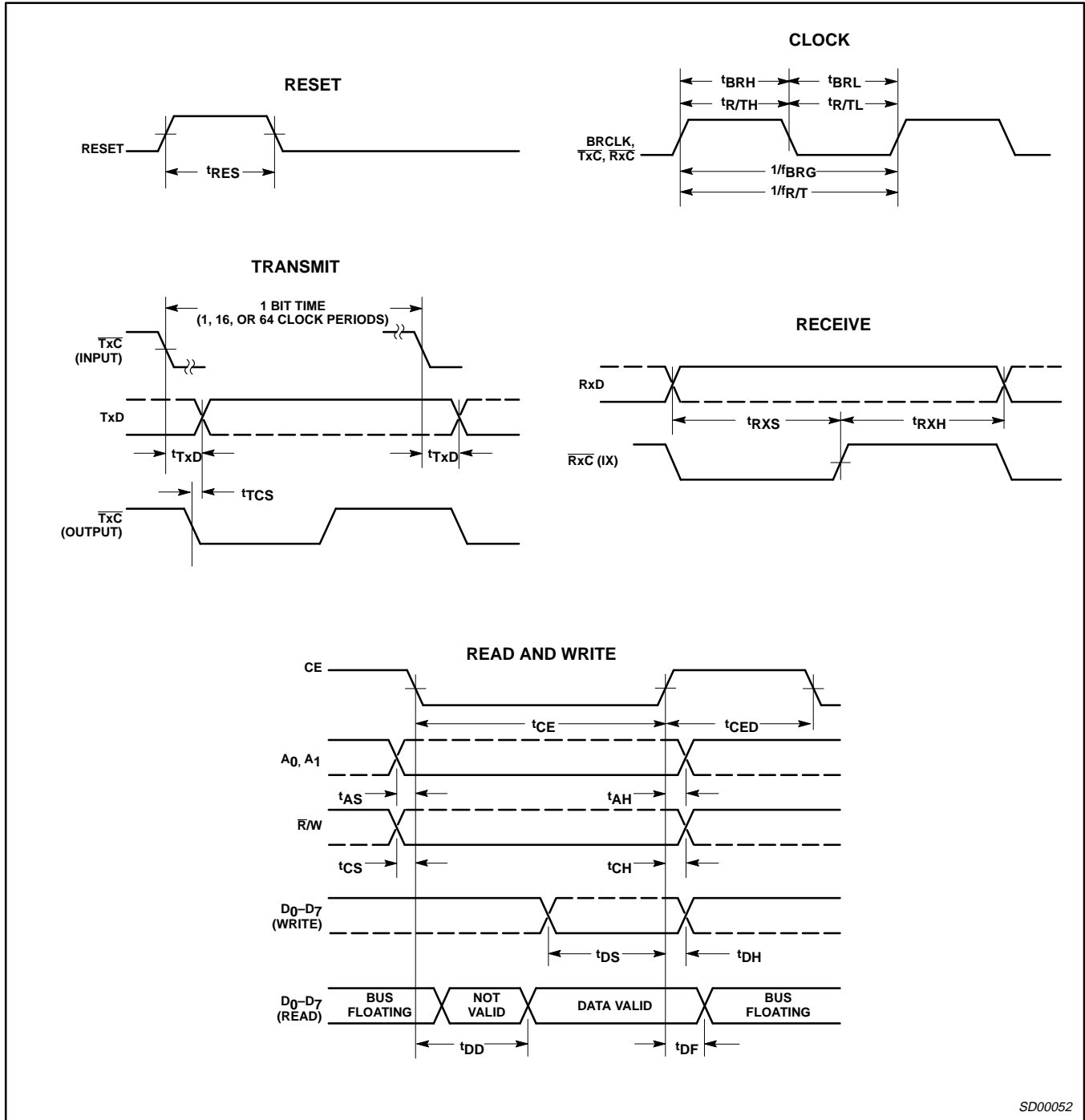

# Programmable communications interface (PCI)

SCN2651

## TIMING DIAGRAMS (Continued)

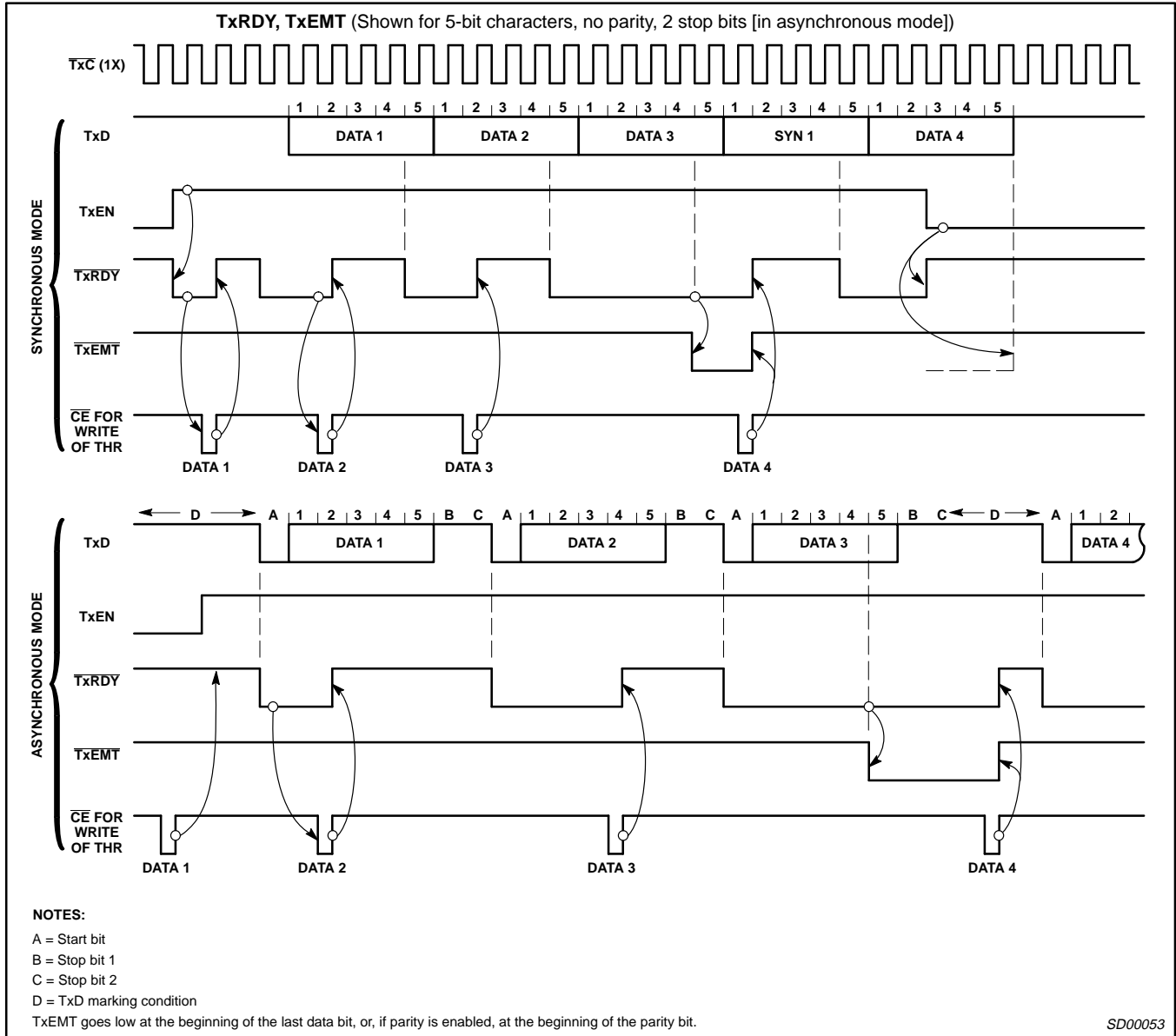

# Programmable communications interface (PCI)

SCN2651

## TIMING DIAGRAMS (Continued)

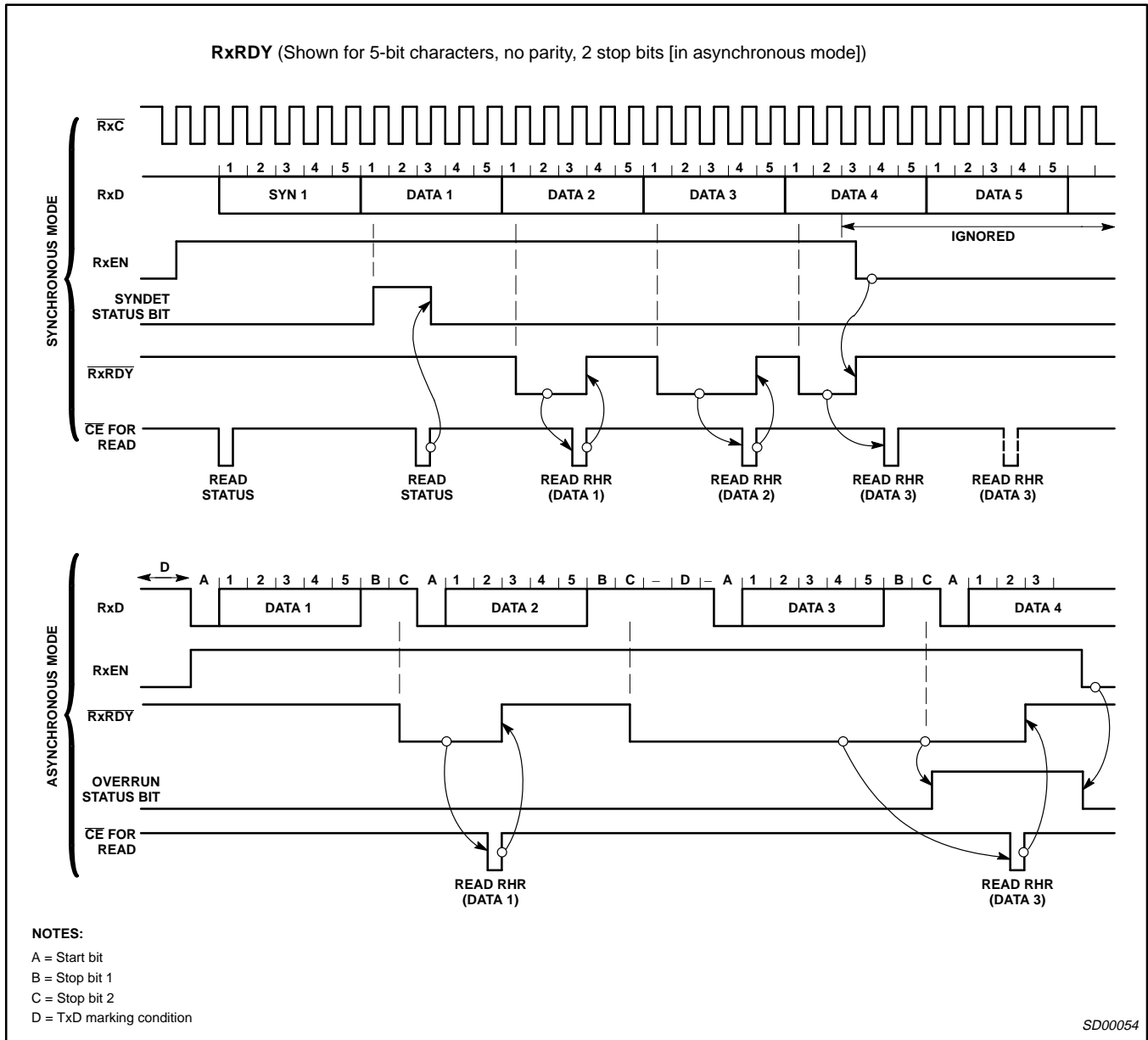

# Programmable communications interface (PCI)

# SCN2651

## TYPICAL APPLICATIONS

### ASYNCHRONOUS INTERFACE TO CRT TERMINAL

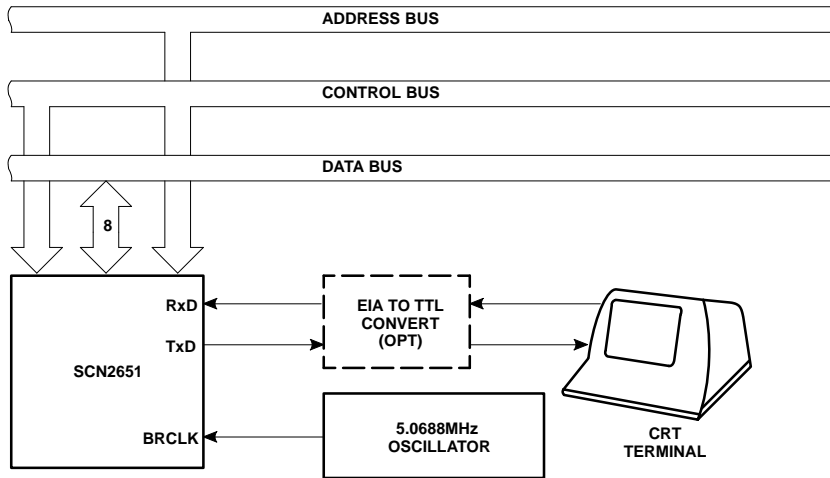

### ASYNCHRONOUS INTERFACE TO TELEPHONE LINES

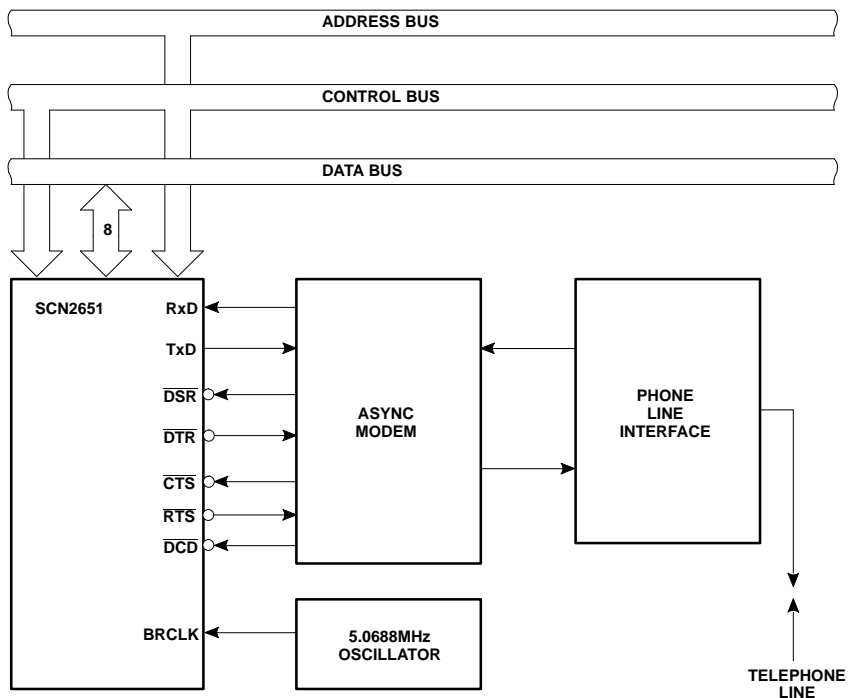

SD00055



# Programmable communications interface (PCI)

# SCN2651

## TYPICAL APPLICATIONS (Continued)

