

To all our customers

Regarding the change of names mentioned in the document, such as Mitsubishi Electric and Mitsubishi XX, to Renesas Technology Corp.

The semiconductor operations of Hitachi and Mitsubishi Electric were transferred to Renesas Technology Corporation on April 1st 2003. These operations include microcomputer, logic, analog and discrete devices, and memory chips other than DRAMs (flash memory, SRAMs etc.) Accordingly, although Mitsubishi Electric, Mitsubishi Electric Corporation, Mitsubishi Semiconductors, and other Mitsubishi brand names are mentioned in the document, these names have in fact all been changed to Renesas Technology Corp. Thank you for your understanding. Except for our corporate trademark, logo and corporate statement, no changes whatsoever have been made to the contents of the document, and these changes do not constitute any alteration to the contents of the document itself.

Note : Mitsubishi Electric will continue the business operations of high frequency & optical devices and power devices.

Renesas Technology Corp.
Customer Support Dept.
April 1, 2003

MITSUBISHI MICROCOMPUTERS

M37702M2AXXFP, M37702M2BXXFP

M37702S1AFP, M37702S1BFP

M37702M2-XXFP and M37702S1FP are respectively unified into M37702M2AXXFP and M37702S1AFP.

SINGLE-CHIP 16-BIT CMOS MICROCOMPUTER

DESCRIPTION

The M37702M2AXXFP is a single-chip microcomputers designed with high-performance CMOS silicon gate technology. This is housed in a 80-pin plastic molded QFP. This single-chip microcomputer has a large 16 M bytes address space, three instruction queue buffers, and two data buffers for high-speed instruction execution. The CPU is a 16-bit parallel processor that can also be switched to perform 8-bit parallel processing. This microcomputer is suitable for office, business, and industrial equipment controller that require high-speed processing of large data.

The differences between M37702M2AXXFP, M37702M2BXXFP, M37702S1AFP and M37702S1BFP are the ROM size and the external clock input frequency as shown below. Therefore, the following descriptions will be for the M37702M2AXXFP unless otherwise noted.

Type name	ROM size	External clock input frequency
M37702M2AXXFP	16 K bytes	16 MHz
M37702M2BXXFP	16 K bytes	25 MHz
M37702S1AFP	External	16 MHz
M37702S1BFP	External	25 MHz

FEATURES

- Number of basic instructions 103
- Memory size ROM 16 K bytes
 RAM 512 bytes
- Instruction execution time
M37702M2AXXFP, M37702S1AFP
(The fastest instruction at 16 MHz frequency) 250 ns

- M37702M2BXXFP, M37702S1BFP
(The fastest instruction at 25 MHz frequency) 160 ns
- Single power supply 5 V ± 10%
- Low power dissipation (at 16 MHz frequency)
..... 60 mW (Typ.)
- Interrupts 19 types 7 levels
- Multiple function 16-bit timer 5 + 3
- UART (may also be synchronous) 2
- 8-bit A-D converter 8-channel inputs
- 12-bit watchdog timer.
- Programmable input/output
(ports P0, P1, P2, P3, P4, P5, P6, P7, P8) 68

APPLICATION

Control devices for office equipment such as copiers, printers, typewriters, facsimiles, word processors, and personal computers
Control devices for industrial equipment such as ME, NC, communication and measuring instruments.

NOTE

Refer to "Chapter 5 PRECAUTIONS" when using this microcomputer.

The M37702M2AXXFP and M37702S1AFP satisfy the timing requirements and the switching characteristics of the former M37702M2-XXFP and M37702S1FP.

PIN CONFIGURATION (TOP VIEW)

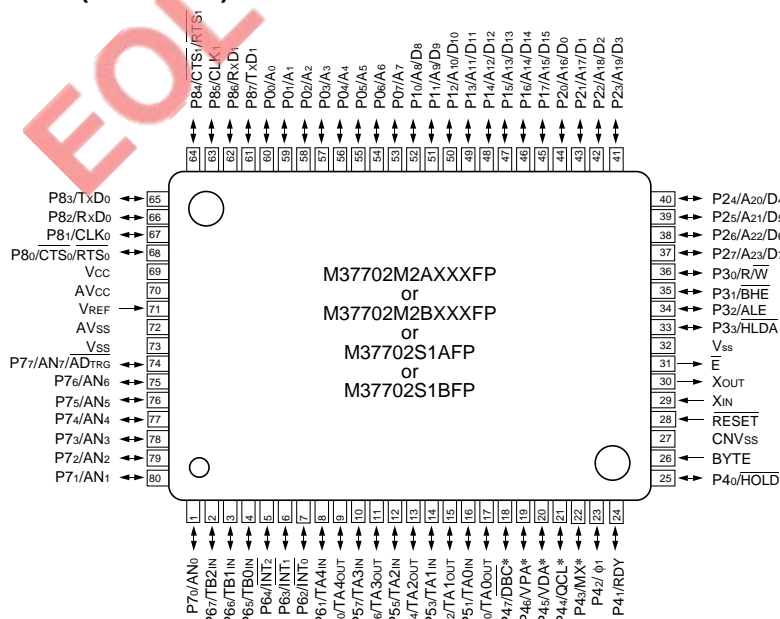

Outline 80P6N-A

*: Used in the evaluation chip mode only

**M37702M2AXXFP, M37702M2BXXFP
M37702S1AFP, M37702S1BFP**

SINGLE-CHIP 16-BIT CMOS MICROCOMPUTER

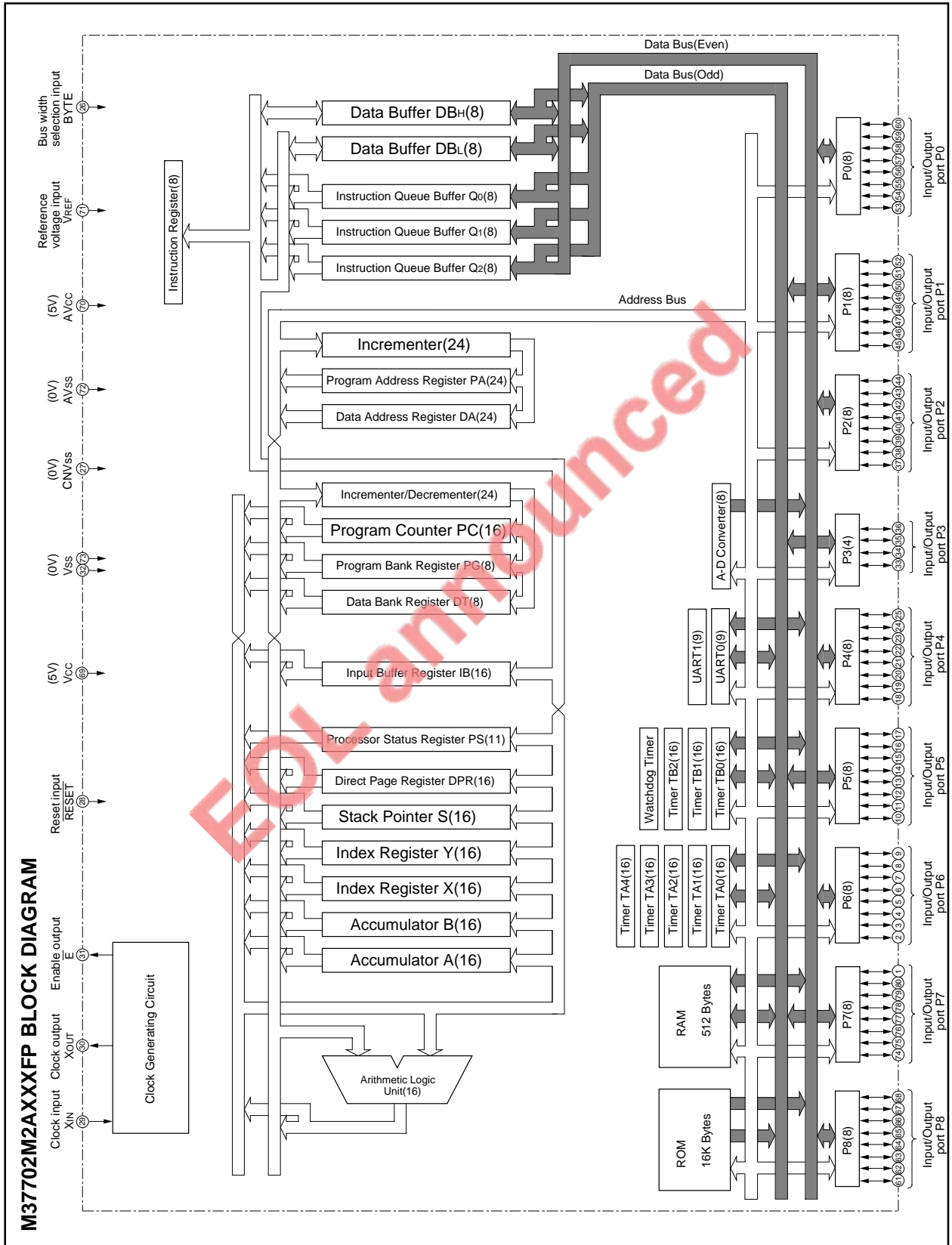

**M37702M2AXXFP, M37702M2BXXFP
M37702S1AFP, M37702S1BFP**

SINGLE-CHIP 16-BIT CMOS MICROCOMPUTER

FUNCTIONS OF M37702M2AXXFP

Parameter		Functions
Number of basic instructions		103
Instruction execution time	M37702M2AXXFP, M37702S1AFP	250 ns (the fastest instruction at external clock 16 MHz frequency)
	M37702M2BXXFP, M37702S1BFP	160 ns (the fastest instruction at external clock 25 MHz frequency)
Memory size	ROM	16 K bytes
	RAM	512 bytes
Input/Output ports	P0 – P2, P4 – P8	8-bit X 8
	P3	4-bit X 1
Multi-function timers	TA0, TA1, TA2, TA3, TA4	16-bit X 5
	TB0, TB1, TB2	16-bit X 3
Serial I/O		(UART or clock synchronous serial I/O) X 2
A-D converter		8-bit X 1 (8 channels)
Watchdog timer		12-bit X 1
Interrupts		3 external types, 16 internal types (Each interrupt can be set the priority levels to 0 – 7.)
Clock generating circuit		Built-in (externally connected to a ceramic resonator or quartz crystal resonator)
Supply voltage		5 V ± 10%
Power dissipation		60 mW (at external clock 16 MHz frequency)
Input/Output characteristic	Input/Output voltage	5 V
	Output current	5 mA
Memory expansion		Maximum 16 M bytes
Operating temperature range		–20 – 85°C
Device structure		CMOS high-performance silicon gate process
Package		80-pin plastic molded QFP

EOL announcement

MITSUBISHI MICROCOMPUTERS
M37702M2AXXFP, M37702M2BXXFP
M37702S1AFP, M37702S1BFP

SINGLE-CHIP 16-BIT CMOS MICROCOMPUTER

PIN DESCRIPTION

Pin	Name	Input/Output	Functions
Vcc, Vss	Power supply		Supply 5 V \pm 10% to Vcc and 0V to Vss.
CNVss	CNVss input	Input	This pin controls the processor mode. Connect to Vss for single-chip mode, and to Vcc for external ROM types.
RESET	Reset input	Input	To enter the reset state, this pin must be kept at a "L" condition which should be maintained for the required time.
XIN	Clock input	Input	These are I/O pins of internal clock generating circuit. Connect a ceramic or quartz crystal resonator between XIN and XOUT. When an external clock is used, the clock source should be connected to the XIN pin and the XOUT pin should be left open.
XOUT	Clock output	Output	
\bar{E}	Enable output	Output	Data or instruction read and data write are performed when output from this pin is "L".
BYTE	Bus width selection input	Input	In memory expansion mode or microprocessor mode, this pin determines whether the external data bus is 8-bit width or 16-bit width. The width is 16 bits when "L" signal inputs and 8 bits when "H" signal inputs.
AVcc, AVss	Analog supply input		Power supply for the A-D converter. Connect AVcc to Vcc and AVss to Vss externally.
VREF	Reference voltage input	Input	This is reference voltage input pin for the A-D converter.
P00 – P07	I/O port P0	I/O	In single-chip mode, port P0 becomes an 8-bit I/O port. An I/O direction register is available so that each pin can be programmed for input or output. These ports are in input mode when reset. Address (A7 – A0) is output in memory expansion mode or microprocessor mode.
P10 – P17	I/O port P1	I/O	In single-chip mode, these pins have the same functions as port P0. When the BYTE pin is set to "L" in memory expansion mode or microprocessor mode and external data bus is 16-bit width, high-order data (D15 – D8) is input or output when \bar{E} output is "L" and an address (A15 – A8) is output when \bar{E} output is "H". If the BYTE pin is "H" that is an external data bus is 8-bit width, only address (A15 – A8) is output.
P20 – P27	I/O port P2	I/O	In single-chip mode, these pins have the same functions as port P0. In memory expansion mode or microprocessor mode low-order data (D7 – D0) is input or output when \bar{E} output is "L" and an address (A23 – A16) is output when \bar{E} output is "H".
P30 – P37	I/O port P3	I/O	In single-chip mode, these pins have the same functions as port P0. In memory expansion mode or microprocessor mode, R/W, BHE, ALE and HLDA signals are output.
P40 – P47	I/O port P4	I/O	In single-chip mode, these pins have the same functions as port P0. In memory expansion mode or microprocessor mode, P40 and P41 become HOLD and RDY input pin respectively. Functions of other pins are the same as in single-chip mode. In single-chip mode or memory expansion mode, port P42 can be programmed for ϕ_1 output pin divided the clock to XIN pin by 2. In microprocessor mode. P42 always has the function as ϕ_1 output pin.
P50 – P57	I/O port P5	I/O	In addition to having the same functions as port P0 in single-chip mode, these pins also function as I/O pins for timer A0, timer A1, timer A2 and timer A3.
P60 – P67	I/O port P6	I/O	In addition to having the same functions as port P0 in single-chip mode, these pins also function as I/O pins for timer A4, external interrupt input INT0, INT1 and INT2 pins, and input pins for timer B0, timer B1 and timer B2.
P70 – P77	I/O port P7	I/O	In addition to having the same functions as port P0 in single-chip mode, these pins also function as analog input AN0 – AN7 input pins. P77 also has an A-D conversion trigger input function.
P80 – P87	I/O port P8	I/O	In addition to having the same functions as port P0 in single-chip mode, these pins also function as RXD, TXD, CLK, CTS/RTS pins for UART 0 and UART 1.

M37702M2AXXFP, M37702M2BXXFP M37702S1AFP, M37702S1BFP

SINGLE-CHIP 16-BIT CMOS MICROCOMPUTER

BASIC FUNCTION BLOCKS

The M37702M2AXXFP contains the following devices on a single chip: ROM and RAM for storing instructions and data, CPU for processing, bus interface unit (which controls instruction prefetch and data read/write between CPU and memory), timers, UART, A-D converter, and other peripheral devices such as I/O ports. Each of these devices are described below.

MEMORY

The memory map is shown in Figure 1. The address space is 16 M bytes from addresses 016 to FFFFF16. The address space is divided into 64 K bytes units called banks. The banks are numbered from 016 to FF16.

Built-in ROM, RAM and control registers for built-in peripheral devices are assigned to bank 016.

The 16 K bytes area from addresses C00016 to FFFF16 is the built-in ROM. Addresses FFD616 to FFFF16 are the RESET and interrupt vector addresses and contain the interrupt vectors. Refer to the section on interrupts for details.

The 512 bytes area from addresses 8016 to 27F16 contains the built-in RAM. In addition to storing data, the RAM is used as stack during a subroutine call, or interrupts.

Assigned to addresses 016 to 7F16 are peripheral devices such as I/O ports, A-D converter, UART, timer, and interrupt control registers.

A 256 bytes direct page area can be allocated anywhere in bank 016 using the direct page register DPR. In direct page addressing mode, the memory in the direct page area can be accessed with two words thus reducing program steps.

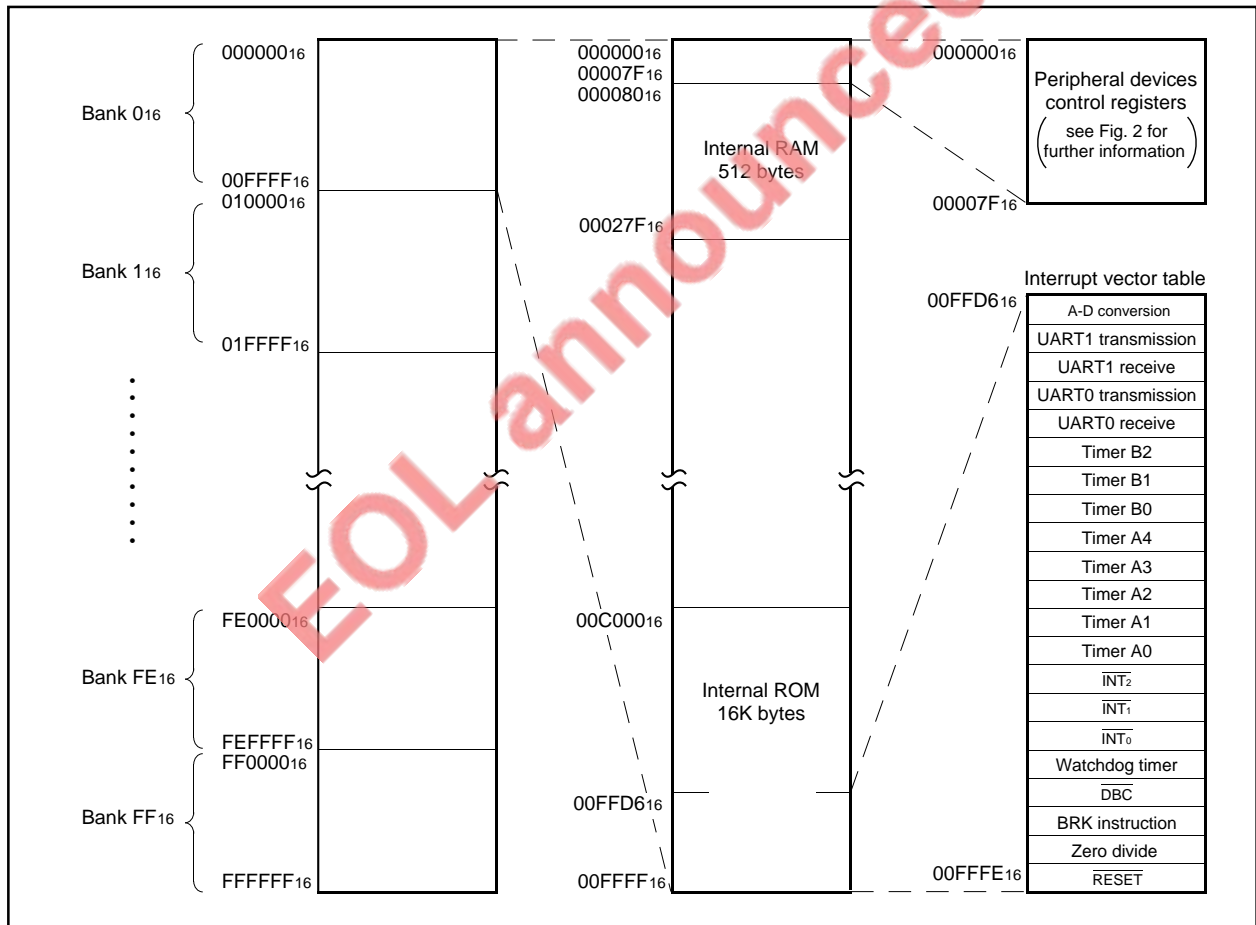

Fig. 1 Memory map

**M37702M2AXXFP, M37702M2BXXFP
M37702S1AFP, M37702S1BFP**

SINGLE-CHIP 16-BIT CMOS MICROCOMPUTER

Address (Hexadecimal notation)		Address (Hexadecimal notation)	
000000		000040	Count start flag
000001		000041	
000002	Port P0	000042	One-shot start flag
000003	Port P1	000043	
000004	Port P0 data direction register	000044	Up-down flag
000005	Port P1 data direction register	000045	
000006	Port P2	000046	
000007	Port P3	000047	Timer A0
000008	Port P2 data direction register	000048	Timer A1
000009	Port P3 data direction register	000049	
00000A	Port P4	00004A	Timer A2
00000B	Port P5	00004B	
00000C	Port P4 data direction register	00004C	Timer A3
00000D	Port P5 data direction register	00004D	Timer A4
00000E	Port P6	00004E	
00000F	Port P7	00004F	Timer B0
000010	Port P6 data direction register	000050	
000011	Port P7 data direction register	000051	Timer B1
000012	Port P8	000052	
000013		000053	Timer B2
000014	Port P8 data direction register	000054	
000015		000055	Timer A0 mode register
000016		000056	Timer A1 mode register
000017		000057	Timer A2 mode register
000018		000058	Timer A3 mode register
000019		000059	Timer A4 mode register
00001A		00005A	Timer B0 mode register
00001B		00005B	Timer B1 mode register
00001C		00005C	Timer B2 mode register
00001D		00005D	Processor mode register
00001E	A-D control register	00005E	
00001F	A-D sweep pin selection register	00005F	
000020	A-D register 0	000060	Watchdog timer
000021		000061	Watchdog timer frequency selection flag
000022	A-D register 1	000062	
000023		000063	
000024	A-D register 2	000064	
000025		000065	
000026	A-D register 3	000066	
000027		000067	
000028	A-D register 4	000068	
000029		000069	
00002A	A-D register 5	00006A	
00002B		00006B	
00002C	A-D register 6	00006C	
00002D		00006D	
00002E	A-D register 7	00006E	
00002F		00006F	
000030	UART 0 transmit/receive mode register	000070	A-D conversion interrupt control register
000031	UART 0 bit rate generator	000071	UART 0 transmission interrupt control register
000032		000072	UART 0 receive interrupt control register
000033	UART 0 transmission buffer register	000073	UART 1 transmission interrupt control register
000034	UART 0 transmit/receive control register 0	000074	UART 1 receive interrupt control register
000035	UART 0 transmit/receive control register 1	000075	Timer A0 interrupt control register
000036	UART 0 receive buffer register	000076	Timer A1 interrupt control register
000037		000077	Timer A2 interrupt control register
000038	UART 1 transmit/receive mode register	000078	Timer A3 interrupt control register
000039	UART 1 bit rate generator	000079	Timer A4 interrupt control register
00003A	UART 1 transmission buffer register	00007A	Timer B0 interrupt control register
00003B		00007B	Timer B1 interrupt control register
00003C	UART 1 transmit/receive control register 0	00007C	Timer B2 interrupt control register
00003D	UART 1 transmit/receive control register 1	00007D	INT ₀ interrupt control register
00003E		00007E	INT ₁ interrupt control register
00003F	UART 1 receive buffer register	00007F	INT ₂ interrupt control register

Fig. 2 Location of peripheral devices and interrupt control registers

MITSUBISHI MICROCOMPUTERS

M37702M2AXXXFP, M37702M2BXXFP M37702S1AFP, M37702S1BFP

SINGLE-CHIP 16-BIT CMOS MICROCOMPUTER

CENTRAL PROCESSING UNIT (CPU)

The CPU has ten registers and is shown in Figure 3. Each of these registers is described below.

ACCUMULATOR A (A)

Accumulator A is the main register of the microcomputer. It consists of 16 bits and the lower 8 bits can be used separately. The data length flag m determines whether the register is used as 16-bit register or as 8-bit register. It is used as a 16-bit register when flag m is "0" and as an 8-bit register when flag m is "1". Flag m is a part of the processor status register (PS) which is described later.

Data operations such as calculations, data transfer, input/output, etc., is executed mainly through the accumulator.

ACCUMULATOR B (B)

Accumulator B has the same functions as accumulator A, but the use of accumulator B requires more instruction bytes and execution cycles than accumulator A.

INDEX REGISTER X (X)

Index register X consists of 16 bits and the lower 8 bits can be used separately. The index register length flag x determines whether the register is used as 16-bit register or as 8-bit register. It is used as a 16-bit register when flag x is "0" and as an 8-bit reg-

ister when flag x is "1". Flag x is a part of the processor status register (PS) which is described later.

In index addressing mode, register X is used as the index register and the contents of this address is added to obtain the real address.

Also, when executing a block transfer instruction MVP or MVN, the contents of index register X indicate the low-order 16 bits of the source data address. The third byte of the MVP and MVN is the high-order 8 bits of the source data address.

INDEX REGISTER Y (Y)

Index register Y consists of 16 bits and the lower 8 bits can be used separately. The index register length flag x determines whether the register is used as 16-bit register or as 8-bit register. It is used as a 16-bit register when flag x is "0" and as an 8-bit register when flag x is "1". Flag x is a part of the processor status register (PS) which is described later.

In index addressing mode, register Y is used as the index register and the contents of this address is added to obtain the real address.

Also, when executing a block transfer instruction MVP or MVN, the contents of index register Y indicate the low-order 16 bits of the destination address. The second byte of the MVP and MVN is the high-order 8 bits of the destination data address.

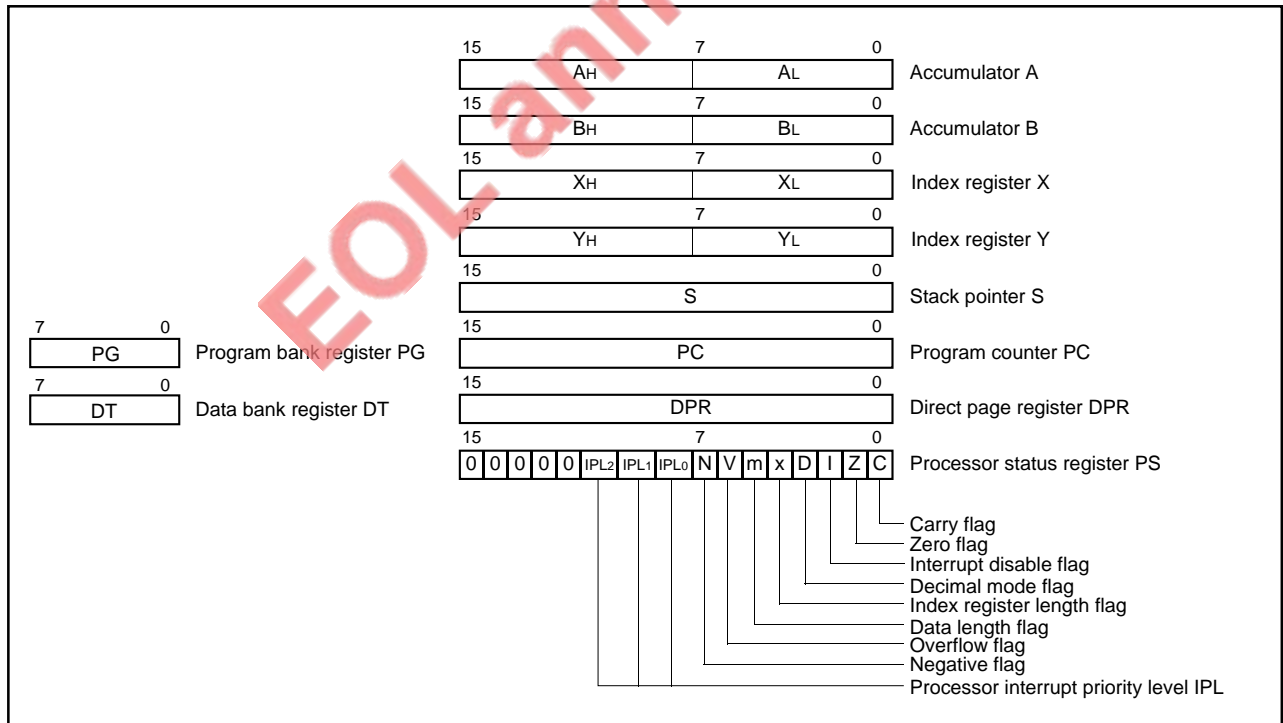

Fig. 3 Register structure

M37702M2AXXFP, M37702M2BXXFP M37702S1AFP, M37702S1BFP

SINGLE-CHIP 16-BIT CMOS MICROCOMPUTER

STACK POINTER (S)

Stack pointer (S) is a 16-bit register. It is used during a subroutine call or interrupts. It is also used during stack, stack pointer relative, or stack pointer relative indirect indexed Y addressing mode.

PROGRAM COUNTER (PC)

Program counter (PC) is a 16-bit counter that indicates the low-order 16-bits of the next program memory address to be executed. There is a bus interface unit between the program memory and the CPU, so that the program memory is accessed through bus interface unit. This is described later.

PROGRAM BANK REGISTER (PG)

Program bank register is an 8-bit register that indicates the high-order 8 bits of the next program memory address to be executed. When a carry occurs by incrementing the contents of the program counter, the contents of the program bank register (PG) is incremented by 1. Also, when a carry or borrow occurs after adding or subtracting the offset value to or from the contents of the program counter (PC) using branch instruction, the contents of the program bank register (PG) is incremented or decremented by 1 so that programs can be written without worrying about bank boundaries.

DATA BANK REGISTER (DT)

Data bank register (DT) is an 8-bit register. With some addressing modes, a part of the data bank register (DT) is used to specify a memory address. The contents of data bank register (DT) is used as the high-order 8 bits of a 24-bit address. Addressing modes that use the data bank register (DT) are direct indirect, direct indexed X indirect, direct indirect indexed Y, absolute, absolute bit, absolute indexed X, absolute indexed Y, absolute bit relative, and stack pointer relative indirect indexed Y.

DIRECT PAGE REGISTER (DPR)

Direct page register (DPR) is a 16-bit register. Its contents is used as the base address of a 256-byte direct page area. The direct page area is allocated in bank 0, but when the contents of DPR is FF01₁₆ or greater, the direct page area spans across bank 0₁₆ and bank 1₁₆. All direct addressing modes use the contents of the direct page register (DPR) to generate the data address. If the low-order 8 bits of the direct page register (DPR) is "00₁₆", the number of cycles required to generate an address is minimized. Normally the low-order 8 bits of the direct page register (DPR) is set to "00₁₆".

PROCESSOR STATUS REGISTER (PS)

Processor status register (PS) is an 11-bit register. It consists of a flag to indicate the result of operation and CPU interrupt levels. Branch operations can be performed by testing the flags C, Z, V, and N.

The details of each processor status register bit are described below.

1. Carry flag (C)

The carry flag contains the carry or borrow generated by the ALU after an arithmetic operation. This flag is also affected by shift and rotate instructions. This flag can be set and reset directly with the SEC and CLC instructions or with the SEP and CLP instructions.

2. Zero flag (Z)

This zero flag is set if the result of an arithmetic operation or data transfer is zero and reset if it is not. This flag can be set and reset directly with the SEP and CLP instructions.

3. Interrupt disable flag (I)

When the interrupt disable flag is set to "1", all interrupts except watchdog timer, DBC, and software interrupt are disabled. This flag is set to "1" automatically when there is an interrupt. It can be set and reset directly with the SEI and CLI instructions or SEP and CLP instructions.

4. Decimal mode flag (D)

The decimal mode flag determines whether addition and subtraction are performed as binary or decimal. Binary arithmetic is performed when this flag is "0". If it is "1", decimal arithmetic is performed with each word treated as two or four digit decimal. Arithmetic operation is performed using four digits when the data length flag m is "0" and with two digits when it is "1". (Decimal operation is possible only with the ADC and SBC instructions.) This flag can be set and reset with the SEP and CLP instructions.

MITSUBISHI MICROCOMPUTERS

M37702M2AXXFP, M37702M2BXXFP M37702S1AFP, M37702S1BFP

SINGLE-CHIP 16-BIT CMOS MICROCOMPUTER

5. Index register length flag (x)

The index register length flag determines whether index register X and index register Y are used as 16-bit registers or as 8-bit registers. The registers are used as 16-bit registers when flag x is "0" and as 8-bit registers when it is "1". This flag can be set and reset with the SEP and CLP instructions.

6. Data length flag (m)

The data length flag determines whether the data length is 16-bit or 8-bit. The data length is 16-bit when flag m is "0" and 8-bit when it is "1". This flag can be set and reset with the SEM and CLM instructions or with the SEP and CLP instructions.

7. Overflow flag (V)

The overflow flag has meaning when addition or subtraction is performed a word as signed binary number. When the data length flag m is "0", the overflow flag is set when the result of addition or subtraction is outside the range between -32768 and +32767. When the data length flag m is "1", the overflow flag is set when the result of addition or subtraction is outside the range between -128 and +127. It is reset in all other cases. The overflow flag can also be set and reset directly with the SEP, and CLV or CLP instructions.

8. Negative flag (N)

The negative flag is set when the result of arithmetic operation or data transfer is negative (If data length flag m is "0", when data bit 15 is "1". If data length flag m is "1", when data bit 7 is "1".) It is reset in all other cases. It can also be set and reset with the SEP and CLP instructions.

9. Processor interrupt priority level (IPL)

The processor interrupt priority level (IPL) consists of 3 bits and determines the priority of processor interrupts from level 0 to level 7. Interrupt is enabled when the interrupt priority of the device requesting interrupt (set using the interrupt control register) is higher than the processor interrupt priority. When interrupt is enabled, the current processor interrupt priority level is saved in a stack and the processor interrupt priority level is replaced by the interrupt priority level of the device requesting the interrupt. Refer to the section on interrupts for more details.

BUS INTERFACE UNIT

The CPU operates on an internal clock frequency which is obtained by dividing the external clock frequency $f(X_{IN})$ by two. This frequency is twice the bus cycle frequency. In order to speed-up processing, a bus interface unit is used to pre-fetch instructions when the data bus is idle. The bus interface unit synchronizes the CPU and the bus and pre-fetches instructions. Figure 4 shows the relationship between the CPU and the bus interface unit. The bus interface unit has a program address register, a 3-byte instruction queue buffer, a data address register, and a 2-byte data buffer. The bus interface unit obtains an instruction code from memory and stores it in the instruction queue buffer, obtains data from memory and stores it in the data buffer, or writes the data from the data buffer to the memory.

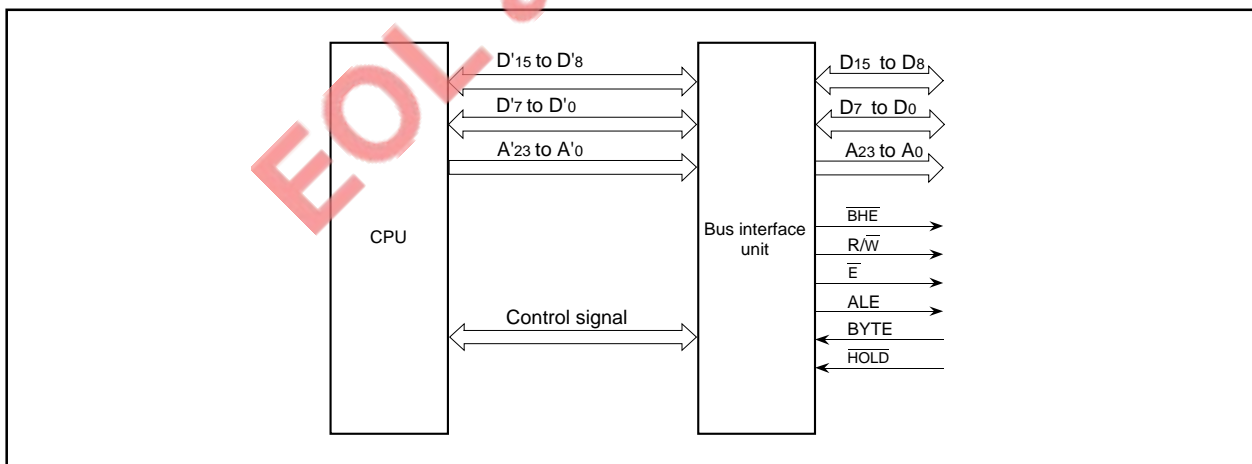

Fig. 4 Relationship between the CPU and the bus interface unit

**M37702M2AXXFP, M37702M2BXXFP
M37702S1AFP, M37702S1BFP**

SINGLE-CHIP 16-BIT CMOS MICROCOMPUTER

The bus interface unit operates using one of the waveforms (1) to (6) shown in Figure 5. The standard waveforms are (1) and (2). The ALE signal is used to latch only the address signal from the multiplexed signal containing data and address.

The \bar{E} signal becomes "L" when the bus interface unit reads an instruction code or data from memory or when it writes data to memory. Whether to perform read or write is controlled by the R/W signal. Read is performed when the R/W signal is "H" state and write is performed when it is "L" state.

Waveform (1) in Figure 5 is used to access a single byte or two bytes simultaneously. To read or write two bytes simultaneously, the first address accessed must be even. Furthermore, when accessing an external memory area in memory expansion mode or microprocessor mode, set the bus width selection input pin BYTE to "L". (external data bus width to 16 bits) The internal memory area is always treated as 16-bit bus width regardless of BYTE.

When performing 16-bit data read or write, if the conditions for simultaneously accessing two bytes are not satisfied, waveform (2) is used to access each byte one by one.

However, when prefetching the instruction code, if the address of the instruction code is odd, waveform (1) is used, and only one byte is read in the instruction queue buffer.

The signals A₀ and BHE in Figure 5 are used to control these cases: 1-byte read from even address, 1-byte read from odd address, 2-byte simultaneous read from even and odd addresses, 1-byte write to even address, 1-byte write to odd address, or 2-byte simultaneous write to even and odd addresses. The A₀ signal that is the address bit 0 is "L" when an even number address is accessed. The BHE signal becomes "L" when an odd number address is accessed.

The bit 2 of processor mode register (address 5E₁₆) is the wait bit. When this bit is set to "0", the "L" width of \bar{E} signal is 2 times as long when accessing an external memory area in memory expansion mode or microprocessor mode. However, the "L" width of \bar{E} signal is not extended when an internal memory area is accessed. When the wait bit is "1", the "L" width of \bar{E} signal is not extended for any access. Waveform (3) is an expansion of the "L" width of \bar{E} signal in waveform (1). Waveform (4), (5), and (6) are expansion of each "L" width of \bar{E} signal in waveform (2), first half of waveform (2), and the last half of waveform (2) respectively.

Instruction code read, data read, and data write are described below.

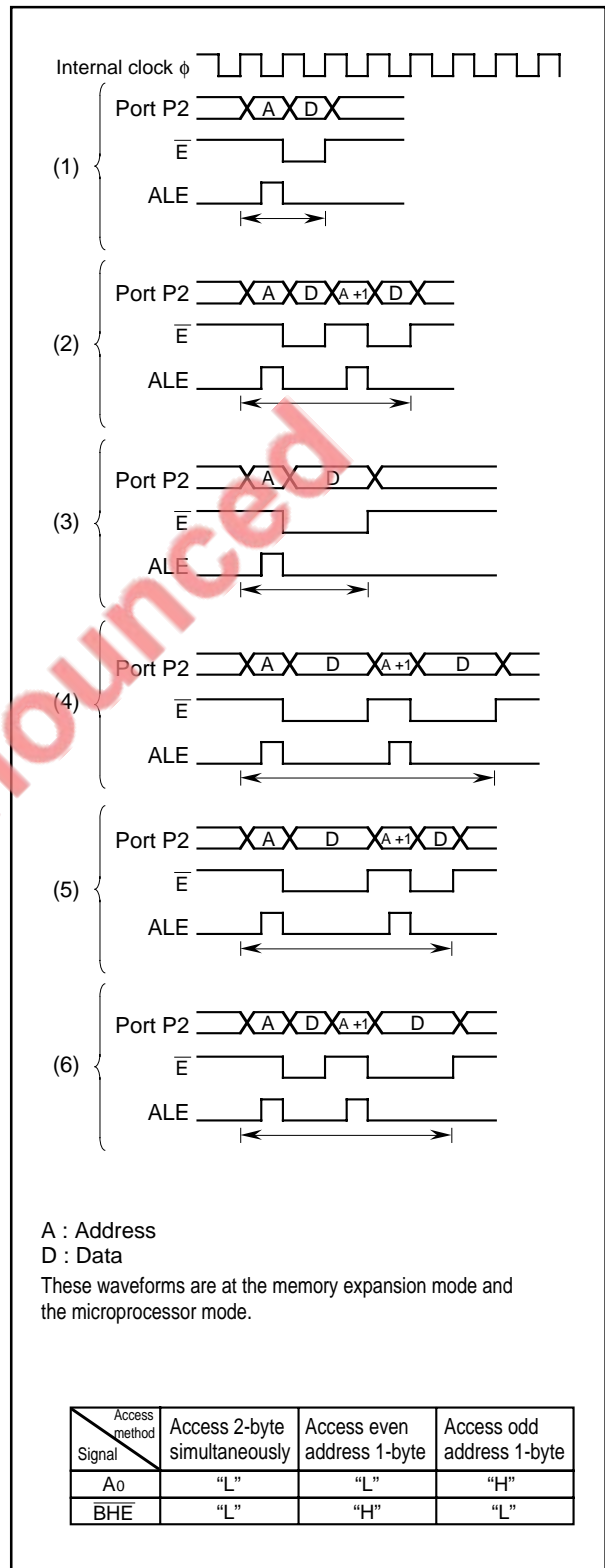

Fig. 5 Relationship between access method and signals A₀ and BHE

**M37702M2AXXFP, M37702M2BXXFP
M37702S1AFP, M37702S1BFP**

SINGLE-CHIP 16-BIT CMOS MICROCOMPUTER

Instruction code read will be described first.

The CPU obtains instruction codes from the instruction queue buffer and executes them. The CPU notifies the bus interface unit that it is requesting an instruction code during an instruction code request cycle. If the requested instruction code is not yet stored in the instruction queue buffer, the bus interface unit halts the CPU until it can store more instructions than requested in the instruction queue buffer.

Even if there is no instruction code request from the CPU, the bus interface unit reads instruction codes from memory and stores them in the instruction queue buffer when the instruction queue buffer is empty or when only one instruction code is stored and the bus is idle on the next cycle.

This is referred to as instruction pre-fetching.

Normally, when reading an instruction code from memory, if the accessed address is even the next odd address is read together with the instruction code and stored in the instruction queue buffer. However, in memory expansion mode or microprocessor mode, if the bus width switching pin BYTE is "H", external data bus width is 8 bits and the address to be read in external memory area is odd, only one byte is read and stored in the instruction queue buffer. Therefore, waveform (1) or (3) in Figure 5 is used for instruction code read.

Data read and write are described below.

The CPU notifies the bus interface unit when performing data read or write. At this time, the bus interface unit halts the CPU if the bus interface unit is already using the bus or if there is a request with higher priority. When data read or write is enabled, the bus interface unit uses one of the waveforms from (1) to (6) in Figure 5 to perform the operation.

During data read, the CPU waits until the entire data is stored in the data buffer. The bus interface unit sends the address received from the CPU to the address bus. Then it reads the memory when the \bar{E} signal is "L" and stores the result in the data buffer.

During data write, the CPU writes the data in the data buffer and the bus interface unit writes it to memory. Therefore, the CPU can proceed to the next step without waiting for write to complete. The bus interface unit sends the address received from the CPU to the address bus. Then when the \bar{E} signal is "L", the bus interface unit sends the data in the data buffer to the data bus and writes it to memory.

**M37702M2AXXFP, M37702M2BXXFP
M37702S1AFP, M37702S1BFP**

SINGLE-CHIP 16-BIT CMOS MICROCOMPUTER

INTERRUPTS

Table 1 shows the interrupt types and the corresponding interrupt vector addresses. Reset is also treated as a type of interrupt and is discussed in this section, too. DBC is an interrupt used during debugging.

Interrupts other than reset, \overline{DBC} , watchdog timer, zero divide, and BRK instruction all have interrupt control registers. Table 2 shows the addresses of the interrupt control registers and Figure 6 shows the bit configuration of the interrupt control register.

Use the SEB and CLB instructions when setting each interrupt control register.

The interrupt request bit is automatically cleared by the hardware during reset or when processing an interrupt.

Also, interrupt request bits other than DBC and watchdog timer can be cleared by software.

$\overline{INT_2}$ to $\overline{INT_0}$ are external interrupts and whether to cause an interrupt at the input level (level sense) or at the edge (edge sense) can be selected with the level sense/edge sense selection bit. Furthermore, the polarity of the interrupt input can be selected with polarity selection bit.

Timer and UART interrupts are described in the respective section. The priority of interrupts when multiple interrupts are caused simultaneously is partially fixed by hardware, but, it can also be adjusted by software as shown in Figure 7. The hardware priority is fixed the following:

reset > \overline{DBC} > watchdog timer > other interrupts

Table 1. Interrupt types and the interrupt vector addresses

Interrupts	Vector addresses
A-D conversion	00FFD6 ₁₆ 00FFD7 ₁₆
UART1 transmit	00FFD8 ₁₆ 00FFD9 ₁₆
UART1 receive	00FFDA ₁₆ 00FFDB ₁₆
UART0 transmit	00FFDC ₁₆ 00FFDD ₁₆
UART0 receive	00FFDE ₁₆ 00FFDF ₁₆
Timer B2	00FFE0 ₁₆ 00FFE1 ₁₆
Timer B1	00FFE2 ₁₆ 00FFE3 ₁₆
Timer B0	00FFE4 ₁₆ 00FFE5 ₁₆
Timer A4	00FFE6 ₁₆ 00FFE7 ₁₆
Timer A3	00FFE8 ₁₆ 00FFE9 ₁₆
Timer A2	00FFEA ₁₆ 00FFEB ₁₆
Timer A1	00FFEC ₁₆ 00FFED ₁₆
Timer A0	00FEE ₁₆ 00FFEF ₁₆
$\overline{INT_2}$ external interrupt	00FFF0 ₁₆ 00FFF1 ₁₆
$\overline{INT_1}$ external interrupt	00FFF2 ₁₆ 00FFF3 ₁₆
$\overline{INT_0}$ external interrupt	00FFF4 ₁₆ 00FFF5 ₁₆
Watchdog timer	00FFF6 ₁₆ 00FFF7 ₁₆
DBC (unusable)	00FFF8 ₁₆ 00FFF9 ₁₆
Break instruction	00FFFA ₁₆ 00FFFB ₁₆
Zero divide	00FFFC ₁₆ 00FFFD ₁₆
Reset	00FFFE ₁₆ 00FFFF ₁₆

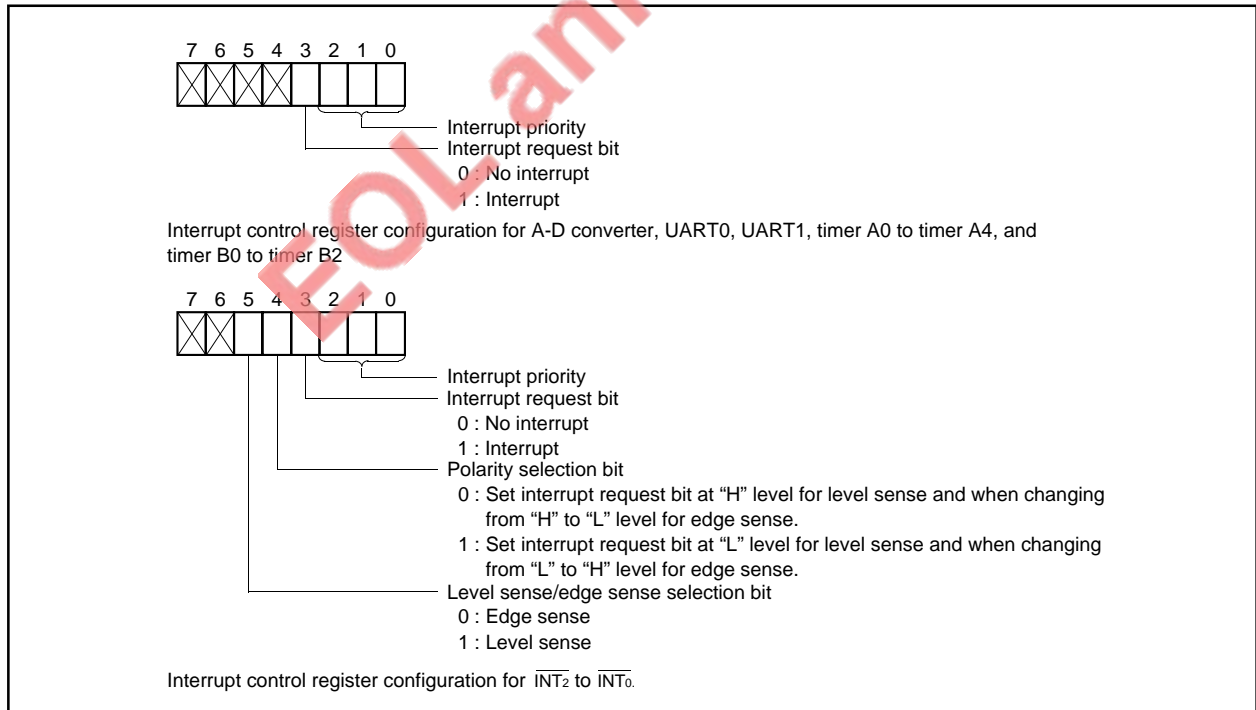

Fig. 6 Interrupt control register configuration

**M37702M2AXXFP, M37702M2BXXFP
M37702S1AFP, M37702S1BFP**

SINGLE-CHIP 16-BIT CMOS MICROCOMPUTER

Table 2. Addresses of interrupt control registers

Interrupt control registers	Addresses
A-D conversion interrupt control register	000070 ₁₆
UART0 transmit interrupt control register	000071 ₁₆
UART0 receive interrupt control register	000072 ₁₆
UART1 transmit interrupt control register	000073 ₁₆
UART1 receive interrupt control register	000074 ₁₆
Timer A0 interrupt control register	000075 ₁₆
Timer A1 interrupt control register	000076 ₁₆
Timer A2 interrupt control register	000077 ₁₆
Timer A3 interrupt control register	000078 ₁₆
Timer A4 interrupt control register	000079 ₁₆
Timer B0 interrupt control register	00007A ₁₆
Timer B1 interrupt control register	00007B ₁₆
Timer B2 interrupt control register	00007C ₁₆
INT ₀ interrupt control register	00007D ₁₆
INT ₁ interrupt control register	00007E ₁₆
INT ₂ interrupt control register	00007F ₁₆

Interrupts caused by a BRK instruction and when dividing by zero are software interrupts and are not included in this list.

Other interrupts previously mentioned are A-D converter, UART, Timer, INT interrupts. The priority of these interrupts can be changed by changing the priority level in the corresponding interrupt control register by software.

Figure 8 shows a diagram of the interrupt priority resolution circuit. When an interrupt is caused, the each interrupt device compares its own priority with the priority from above and if its own priority is higher, then it sends the priority below and requests the interrupt. If the priorities are the same, the one above has priority.

This comparison is repeated to select the interrupt with the highest priority among the interrupts that are being requested. Finally the selected interrupt is compared with the processor interrupt priority level (IPL) contained in the processor status register (PS) and the request is accepted if it is higher than IPL and the interrupt disable flag I is "0". The request is not accepted if flag I is "1". The reset, \overline{DBC} , and watchdog timer interrupts are not affected by the interrupt disable flag I.

When an interrupt is accepted, the contents of the processor status register (PS) is saved to the stack and the interrupt disable flag I is set to "1".

Furthermore, the interrupt request bit of the accepted interrupt is cleared to "0" and the processor interrupt priority level (IPL) in the processor status register (PS) is replaced by the priority level of the accepted interrupt.

Therefore, multi-level priority interrupts are possible by resetting the interrupt disable flag I to "0" and enable further interrupts.

For reset, \overline{DBC} , watchdog timer, zero divide, and BRK instruction interrupts, which do not have an interrupt control register, the processor interrupt level (IPL) is set as shown in Table 3.

Priority resolution is performed by latching the interrupt request bit and interrupt priority level so that they do not change. They are sampled at the first half and latched at the last half of the operation code fetch cycle.

Because priority resolution takes some time, no sampling pulse is generated for a certain interval even if it is the next operation code fetch cycle.

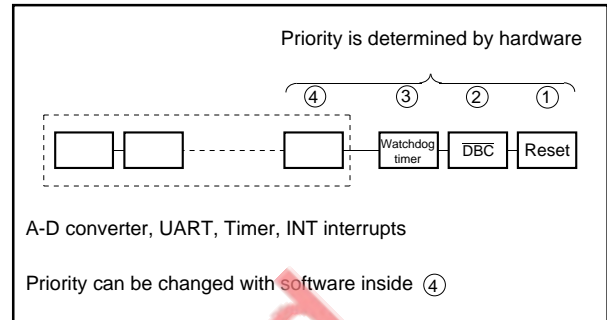

Fig. 7 Interrupt priority

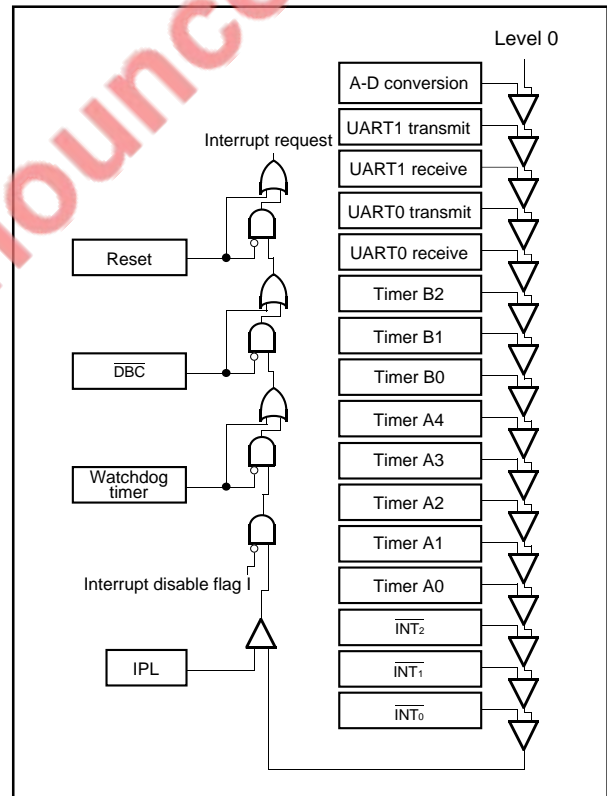

Fig. 8 Interrupt priority resolution

MITSUBISHI MICROCOMPUTERS

M37702M2AXXFP, M37702M2BXXFP M37702S1AFP, M37702S1BFP

SINGLE-CHIP 16-BIT CMOS MICROCOMPUTER

As shown in Figure 9, there are three different interrupt priority resolution time from which one is selected by software. After the selected time has elapsed, the highest priority is determined and is processed after the currently executing instruction has been completed.

The time is selected with bits 4 and 5 of the processor mode register (address 5E16) shown in Figure 10. Table 4 shows the relationship between these bits and the number of cycles. After a reset, the processor mode register is initialized to "0016" and therefore, the longest time is selected.

However, the shortest time should be selected by software.

Table 3. Value set in processor interrupt level (IPL) during an interrupt

Interrupt types	Setting value
Reset	0
DBC	7
Watchdog timer	7
Zero divide	Not change value of IPL.
BRK instruction	Not change value of IPL.

Table 4. Relationship between priority level resolution time selection bit and number of cycles

Priority level resolution time selection bit		Number of cycles
Bit 5	Bit 4	
0	0	7 cycles of ϕ
0	1	4 cycles of ϕ
1	0	2 cycles of ϕ

ϕ : internal clock

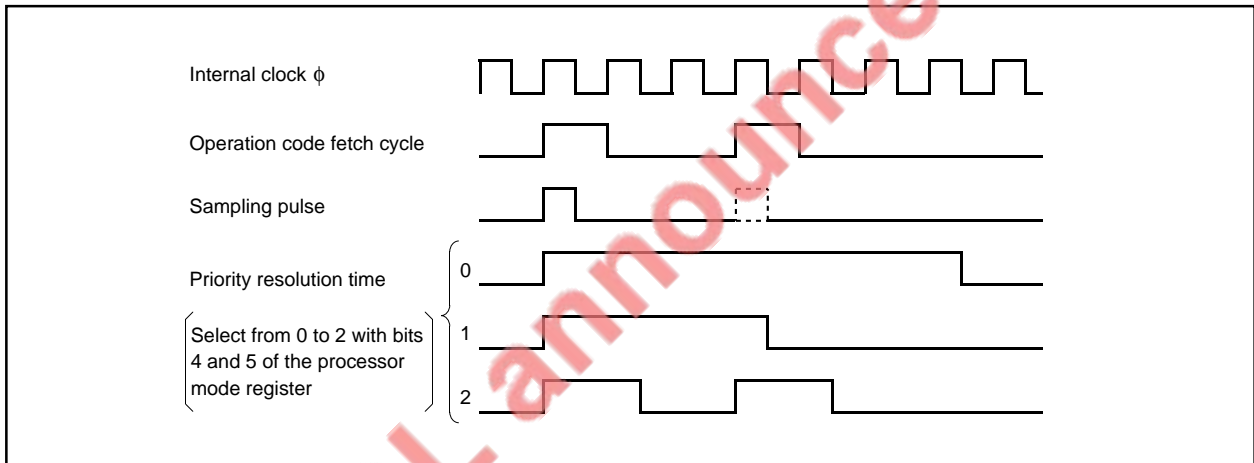

Fig. 9 Interrupt priority resolution time

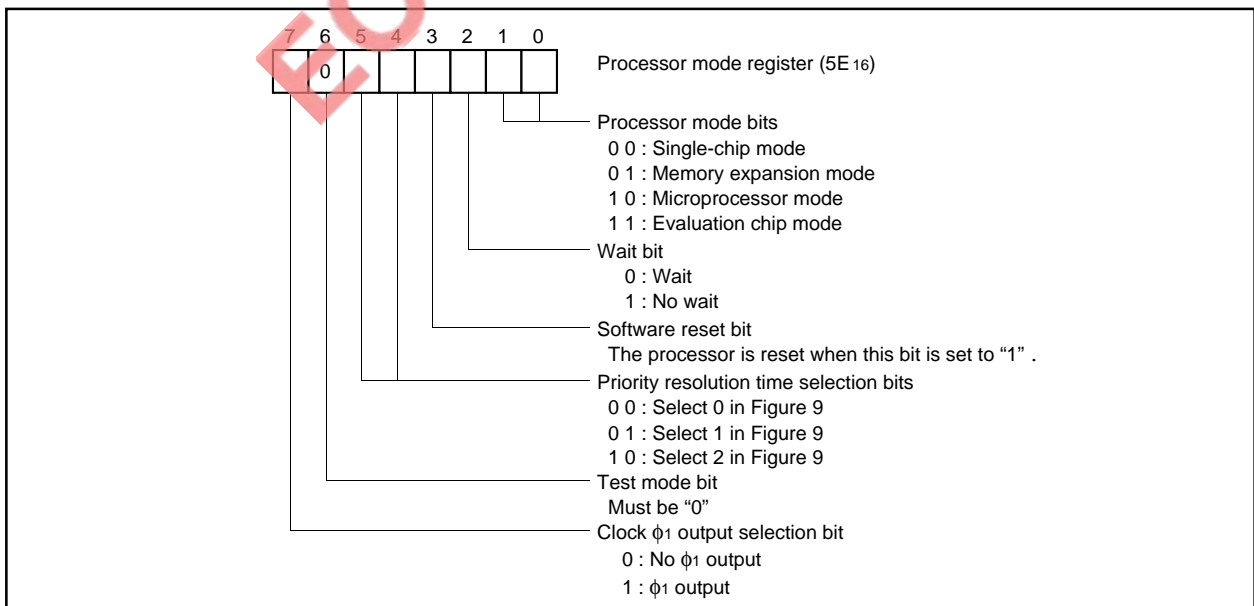

Fig. 10 Processor mode register configuration

**M37702M2AXXFP, M37702M2BXXFP
M37702S1AFP, M37702S1BFP**

SINGLE-CHIP 16-BIT CMOS MICROCOMPUTER

TIMER

There are eight 16-bit timers. They are divided by type into timer A (5) and timer B (3).

The timer I/O pins are shared with I/O pins for port P5 and P6. To use these pins as timer input pins, the data direction register bit corresponding to the pin must be cleared to "0" to specify input mode.

TIMER A

Figure 11 shows a block diagram of timer A.

Timer A has four modes; timer mode, event counter mode, one-shot pulse mode, and pulse width modulation mode. The mode is selected with bits 0 and 1 of the timer Ai mode register (i = 0 to 4). Each of these modes is described below.

(1) Timer mode [00]

Figure 12 shows the bit configuration of the timer Ai mode register during timer mode. Bits 0, 1, and 5 of the timer Ai mode register must always be "0" in timer mode.

Bit 3 is ignored if bit 4 is "0".

Bits 6 and 7 are used to select the timer counter source.

The counting of the selected clock starts when the count start flag is "1" and stops when it is "0".

Figure 13 shows the bit configuration of the count start flag. The counter is decremented, an interrupt is caused and the interrupt request bit in the timer Ai interrupt control register is set when the contents becomes 0000₁₆. At the same time, the contents of the reload register is transferred to the counter and count is continued.

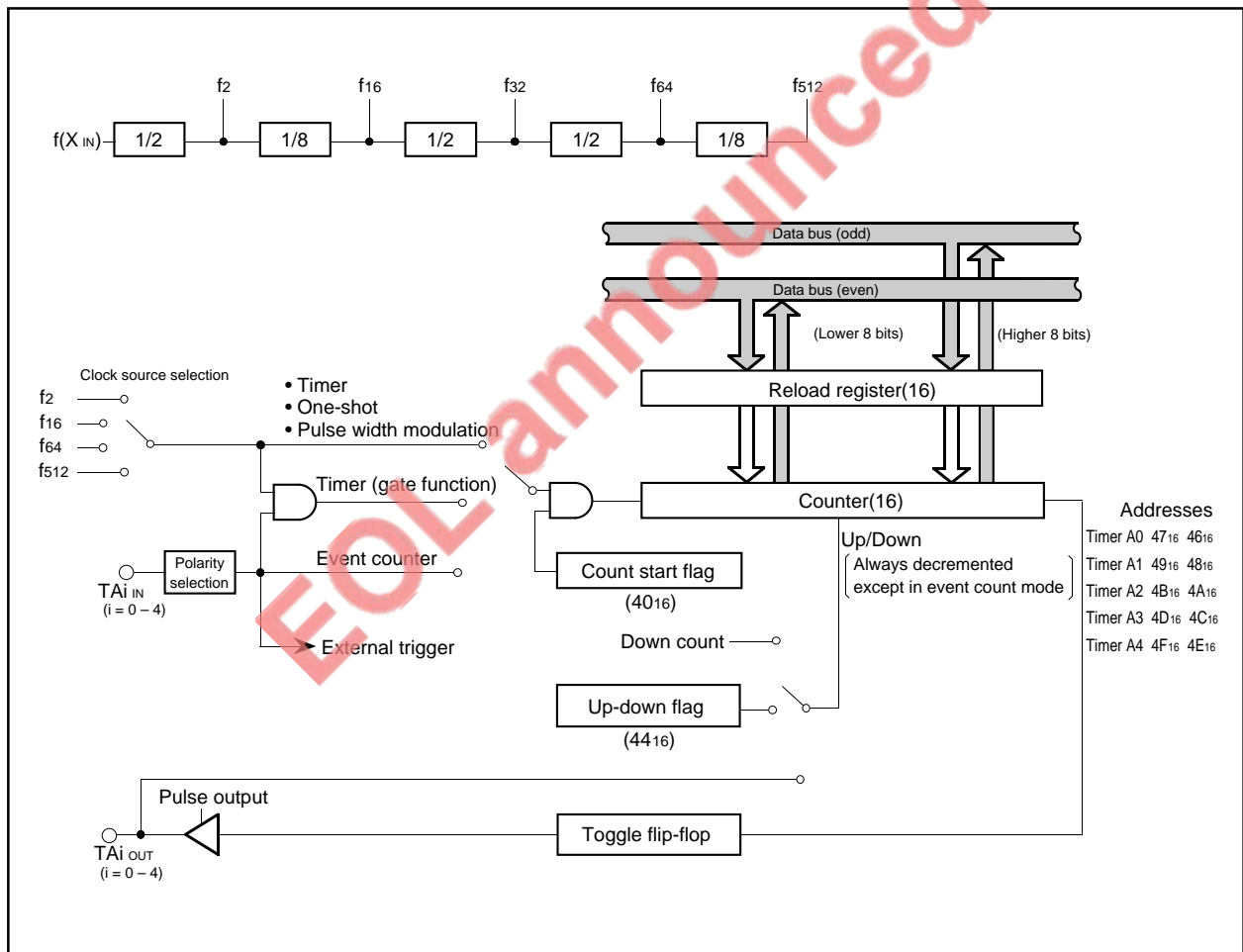

Fig. 11 Block diagram of timer A

**M37702M2AXXFP, M37702M2BXXFP
M37702S1AFP, M37702S1BFP**

SINGLE-CHIP 16-BIT CMOS MICROCOMPUTER

When bit 2 of the timer Ai mode register is "1", the output is generated from TAIOUT pin. The output is toggled each time the contents of the counter reaches to 0000₁₆. When the contents of the count start flag is "0", "L" is output from TAIOUT pin.

When bit 2 is "0", TAIOUT can be used as a normal port pin. When bit 4 is "0", TAIIN can be used as a normal port pin. When bit 4 is "1", counting is performed only while the input signal from the TAIIN pin is "H" or "L" as shown in Figure 14. Therefore, this can be used to measure the pulse width of the TAIIN input signal. Whether to count while the input signal is "H" or while it is "L" is determined by bit 3. If bit 3 is "1", counting is performed while the TAIIN pin input signal is "H" and if bit 3 is "0", counting is performed

while it is "L".

Note that the duration of "H" or "L" on the TAIIN pin must be two or more cycles of the timer count source.

When data is written to timer Ai register with timer Ai halted, the same data is also written to the reload register and the counter. When data is written to timer Ai which is busy, the data is written to the reload register, but not to the counter. The counter is reloaded with new data from the reload register at the next reload timer. The contents of the counter can be read at any time.

When the value set in the timer Ai register is n, the timer frequency dividing ratio is 1/(n + 1).

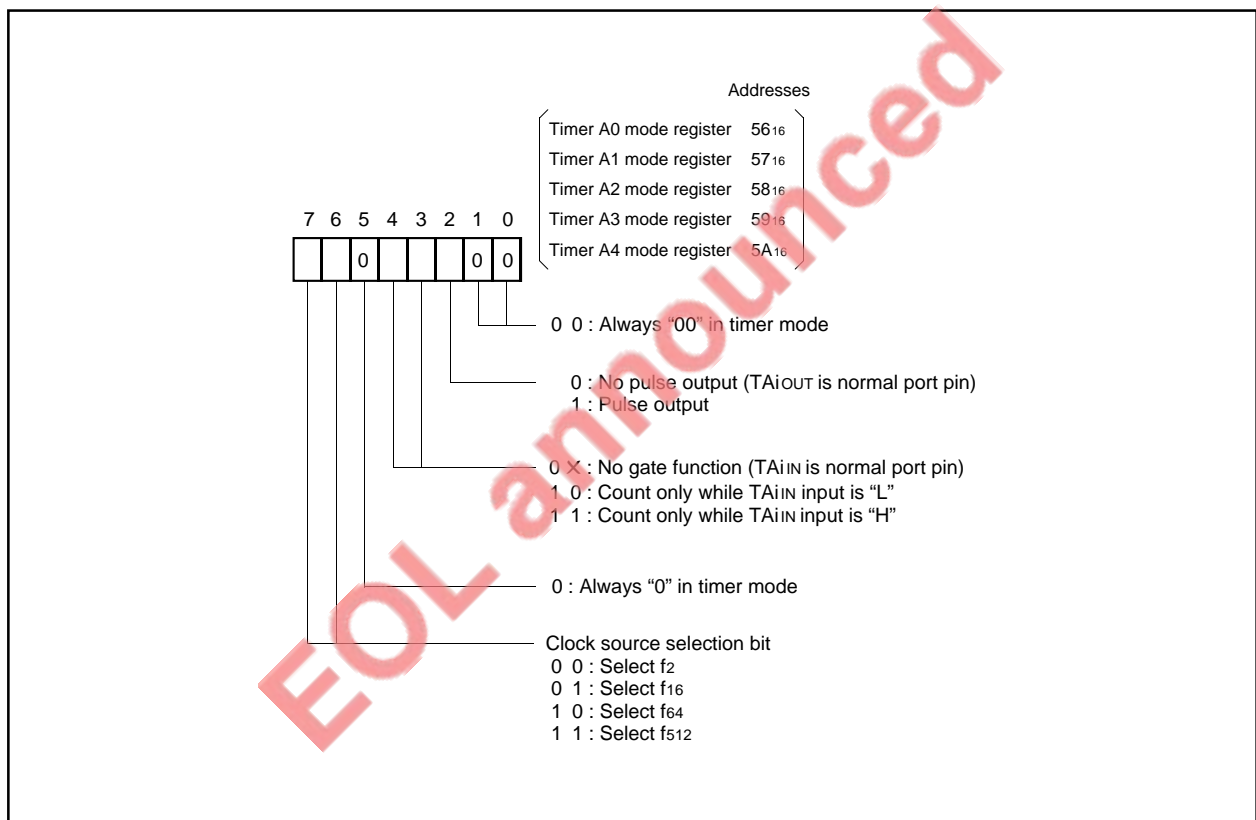

Fig. 12 Timer Ai mode register bit configuration during timer mode

MITSUBISHI MICROCOMPUTERS

M37702M2AXXFP, M37702M2BXXFP
M37702S1AFP, M37702S1BFP

SINGLE-CHIP 16-BIT CMOS MICROCOMPUTER

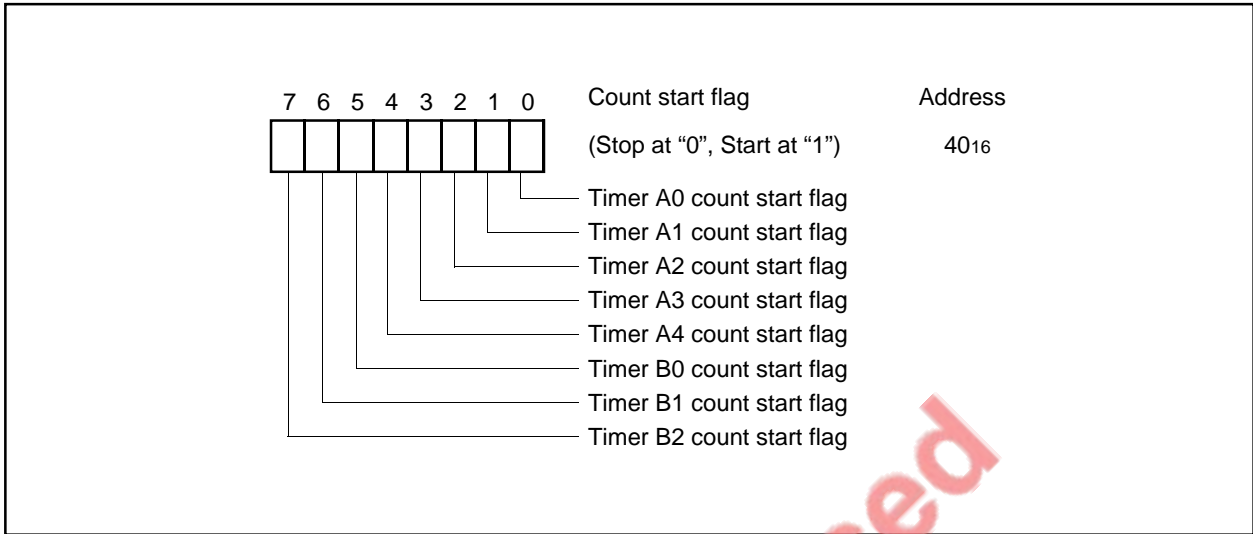

Fig. 13 Count start flag bit configuration

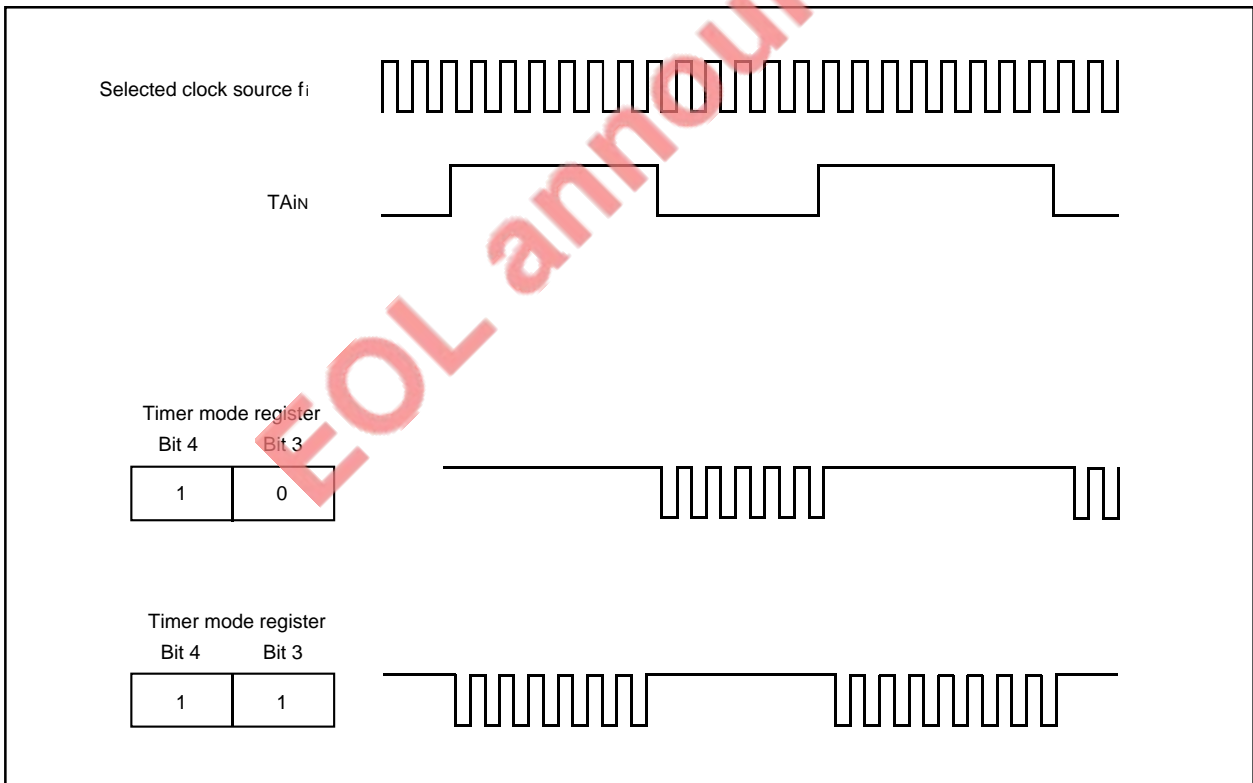

Fig. 14 Count waveform when gate function is available

M37702M2AXXFP, M37702M2BXXFP
M37702S1AFP, M37702S1BFP

SINGLE-CHIP 16-BIT CMOS MICROCOMPUTER

(2) Event counter mode [01]

Figure 15 shows the bit configuration of the timer Ai mode register during event counter mode. In event counter mode, the bit 0 of the timer Ai mode register must be "1" and bit 1 and 5 must be "0".

The input signal from the TAIiN pin is counted when the count start flag shown in Figure 13 is "1" and counting is stopped when it is "0".

Count is performed at the fall of the input signal when bit 3 is "0" and at the rise of the signal when it is "1".

In event counter mode, whether to increment or decrement the count can be selected with the up-down flag or the input signal from the TAIOUT pin.

When bit 4 of the timer Ai mode register is "0", the up-down flag is used to determine whether to increment or decrement the count (decrement when the flag is "0" and increment when it is "1"). Figure 16 shows the bit configuration of the up-down flag.

When bit 4 of the timer Ai mode register is "1", the input signal from the TAIOUT pin is used to determine whether to increment or decrement the count. However, note that bit 2 must be "0" if bit 4 is "1" because if bit 2 is "1", TAIOUT pin becomes an output pin with pulse output.

The count is decremented when the input signal from the TAIOUT pin is "L" and incremented when it is "H". Determine the level of the input signal from the TAIOUT pin before valid edge is input to the TAIiN pin.

An interrupt request signal is generated and the interrupt request bit in the timer Ai interrupt control register is set when the counter reaches 0000₁₆ (decrement count) or FFFF₁₆ (increment count). At the same time, the contents of the reload register is transferred to the counter and the count is continued.

When bit 2 is "1" and the counter reaches 0000₁₆ (decrement count) or FFFF₁₆ (increment count), the waveform reversing polarity is output from TAIOUT pin.

If bit 2 is "0", TAIOUT pin can be used as a normal port pin. However, if bit 4 is "1" and the TAIOUT pin is used as an output pin, the output from the pin changes the count direction. Therefore, bit 4 should be "0" unless the output from the TAIOUT pin is to be used to select the count direction.

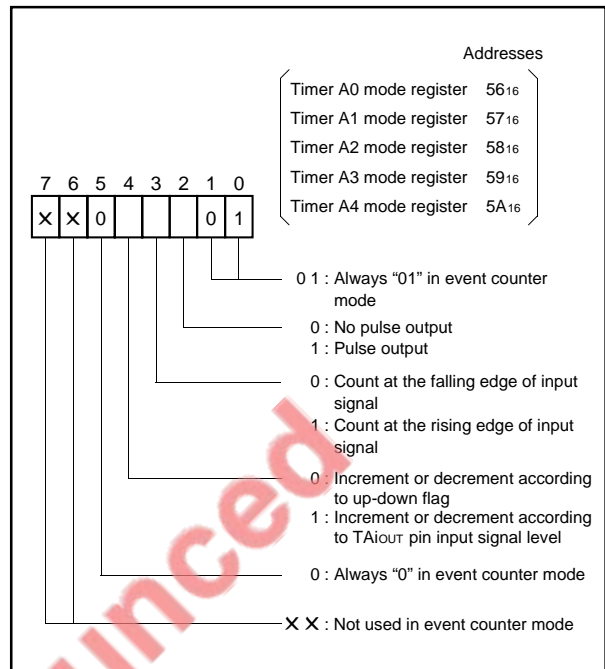

Fig. 15 Timer Ai mode register bit configuration during event counter mode

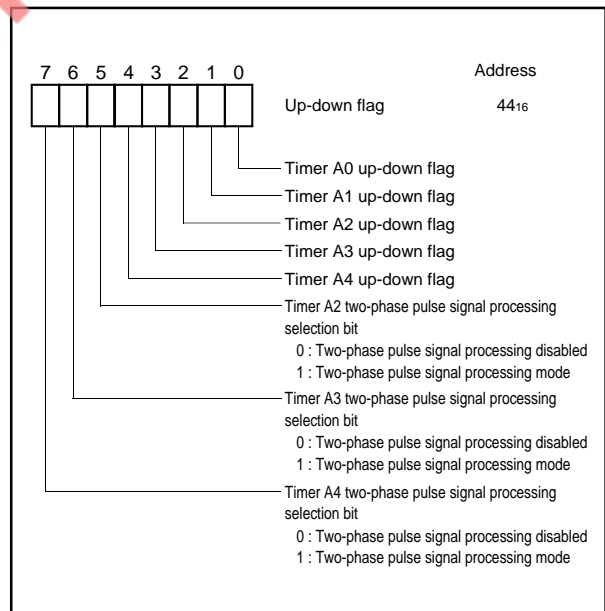

Fig. 16 Up-down flag bit configuration

**M37702M2AXXFP, M37702M2BXXFP
M37702S1AFP, M37702S1BFP**

SINGLE-CHIP 16-BIT CMOS MICROCOMPUTER

Data write and data read are performed in the same way as for timer mode. That is, when data is written to timer A_i halted, it is also written to the reload register and the counter. When data is written to timer A_i which is busy, the data is written to the reload register, but not to the counter. The counter is reloaded with new data from the reload register at the next reload time. The counter can be read at any time.

In event counter mode, whether to increment or decrement the counter can also be determined by supplying two-phase pulse input with phase shifted by 90° to timer A₂, A₃, or A₄. There are two types of two-phase pulse processing operations. One uses timers A₂ and A₃, and the other uses timer A₄. In either processing operation, two-phase pulse is input in the same way, that is, pulses out of phase by 90° are input at the TA_jOUT (j = 2 to 4) pin and TA_jIN pin.

When timers A₂ and A₃ are used, as shown in Figure 17, the count is incremented when a rising edge is input to the TAKIN pin after the level of TAKOUT (k = 2, 3) pin changes from "L" to "H", and when the falling edge is inserted, the count is decremented.

For timer A₄, as shown in Figure 18, when a phase related pulse with a rising edge input to the TA₄IN pin is input after the level of TA₄OUT pin changes from "L" to "H", the count is incremented at the respective rising edge and falling edge of the TA₄OUT pin and TA₄IN pin.

When a phase related pulse with a falling edge input to the TA₄OUT pin is input after the level of TA₄IN pin changes from "H" to "L", the count is decremented at the respective rising edge and falling edge of the TA₄IN pin and TA₄OUT pin. When performing this two-phase pulse signal processing, timer A_j mode register bit 0 and bit 4 must be set to "1" and bits 1, 2, 3, and 5 must be "0".

Bits 6 and 7 are ignored. Note that bits 5, 6, and 7 of the up-down flag register (44₁₆) are the two-phase pulse signal processing selection bit for timer A₂, A₃, and A₄ respectively. Each timer operates in normal event counter mode when the corresponding bit is "0" and performs two-phase pulse signal processing when it is "1".

Count is started by setting the count start flag to "1". Data write and read are performed in the same way as for normal event counter mode. Note that the direction register of the input port must be set to input mode because two-phase pulse signal is input. Also, there can be no pulse output in this mode.

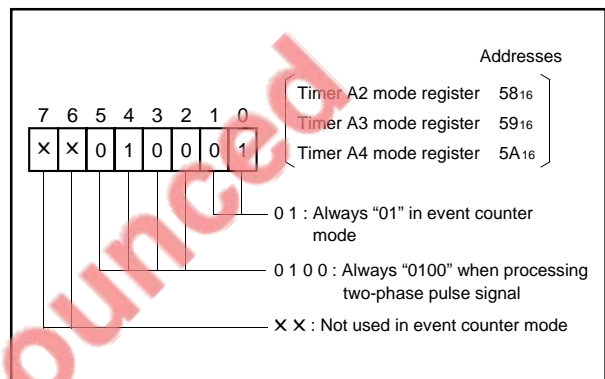

Fig. 19 Timer A_j mode register bit configuration when performing two-phase pulse signal processing in event counter mode

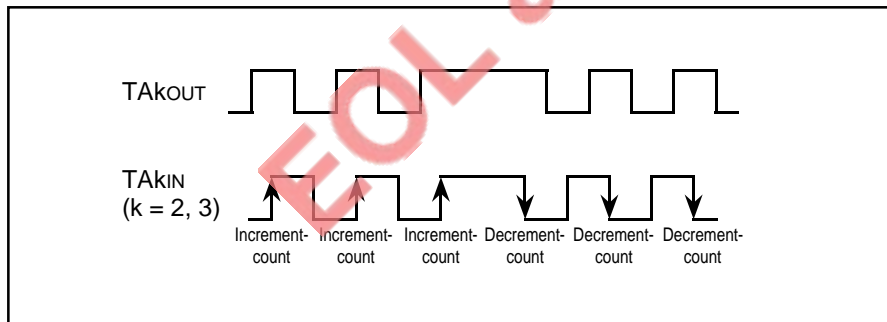

Fig. 17 Two-phase pulse processing operation of timer A₂ and timer A₃

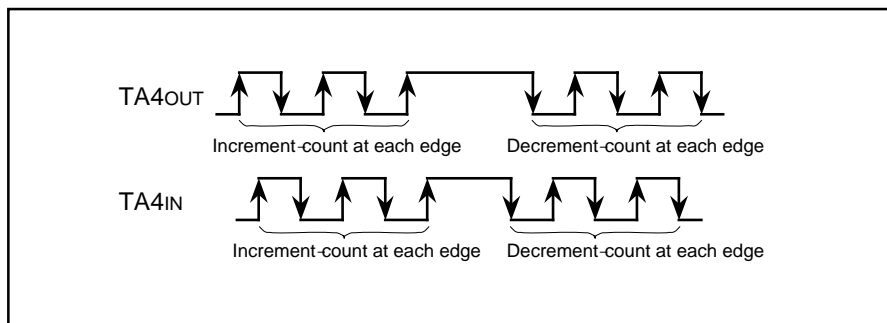

Fig. 18 Two-phase pulse processing operation of timer A₄

(3) One-shot pulse mode [10]

Figure 20 shows the bit configuration of the timer Ai mode register during one-shot pulse mode. In one-shot pulse mode, bit 0 and bit 5 must be "0" and bit 1 and bit 2 must be "1".

The trigger is enabled when the count start flag is "1". The trigger can be generated by software or it can be input from the TAIIN pin. Software trigger is selected when bit 4 is "0" and the input signal from the TAIIN pin is used as the trigger when it is "1".

Bit 3 is used to determine whether to trigger at the fall of the trigger signal or at the rise. The trigger is at the fall of the trigger signal when bit 3 is "0" and at the rise of the trigger signal when it is "1".

Software trigger is generated by setting the bit in the one-shot start flag corresponding to each timer.

Figure 21 shows the bit configuration of the one-shot start flag.

As shown in Figure 22, when a trigger signal is received, the counter counts the clock selected by bits 6 and 7.

If the contents of the counter is not 00001₆, the TAIOUT pin goes "H" when a trigger signal is received. The count direction is decrement.

When the counter reaches 0001₆, The TAIOUT pin goes "L" and count is stopped. The contents of the reload register is transferred to the counter. At the same time, an interrupt request signal is generated and the interrupt request bit in the timer Ai interrupt control register is set. This is repeated each time a trigger signal is received. The output pulse width is

$$\frac{1}{\text{pulse frequency of the selected clock}} \times (\text{counter's value at the time of trigger}).$$

If the count start flag is "0", TAIOUT goes "L". Therefore, the value corresponding to the desired pulse width must be written to timer Ai before setting the timer Ai count start flag.

As shown in Figure 23, a trigger signal can be received before the operation for the previous trigger signal is completed. In this case, the contents of the reload register is transferred to the counter by the trigger and then that value is decremented.

Except when retriggering while operating, the contents of the reload register is not transferred to the counter by triggering.

When retriggering, there must be at least one timer count source cycle before a new trigger can be issued.

Data write is performed the same way as for timer mode. When data is written in timer Ai halted, it is also written to the reload register and the counter.

When data is written to timer Ai which is busy, the data is written to the reload register, but not to the counter. The counter is reloaded with new data from the reload register at the next reload time.

Undefined data is read when timer Ai is read.

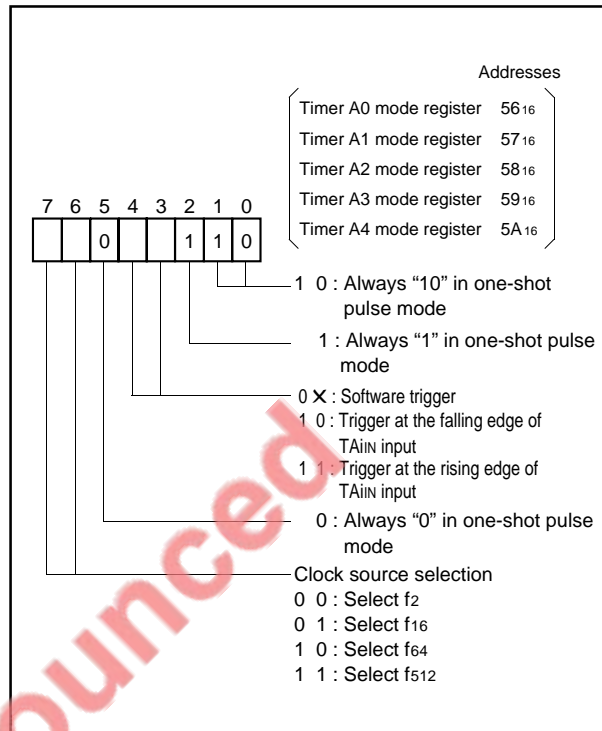

Fig. 20 Timer Ai mode register bit configuration during one-shot pulse mode

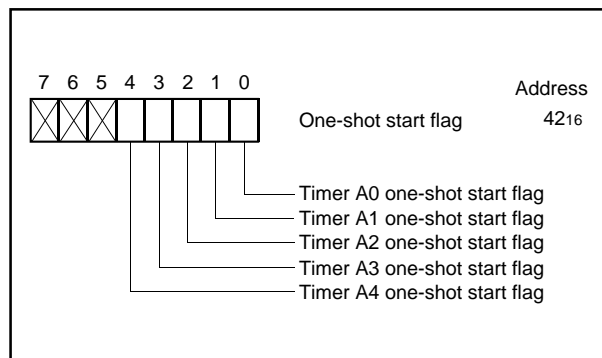

Fig. 21 One-shot start flag bit configuration

MITSUBISHI MICROCOMPUTERS
M37702M2AXXFP, M37702M2BXXFP
M37702S1AFP, M37702S1BFP

SINGLE-CHIP 16-BIT CMOS MICROCOMPUTER

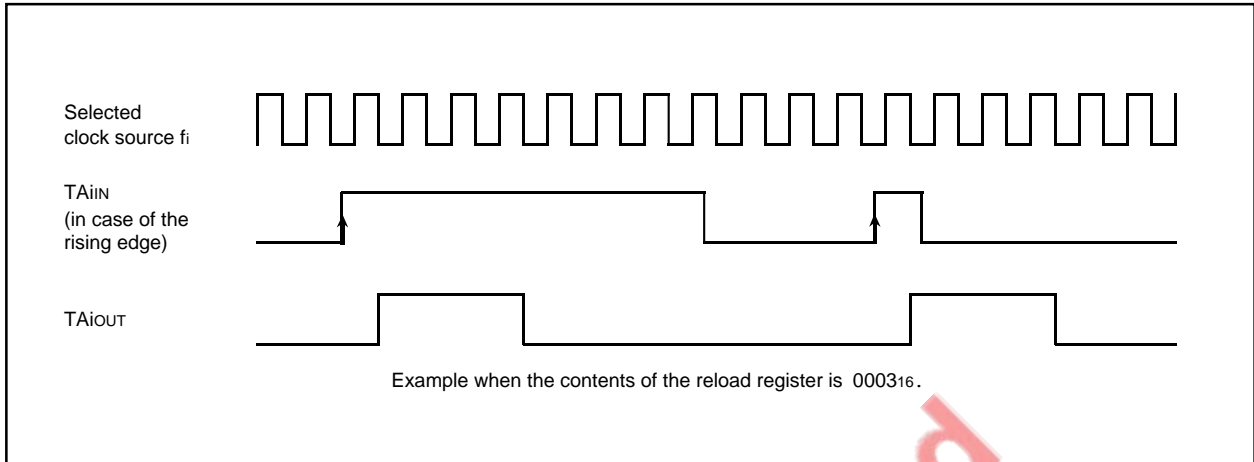

Fig. 22 Pulse output example when external rising edge is selected

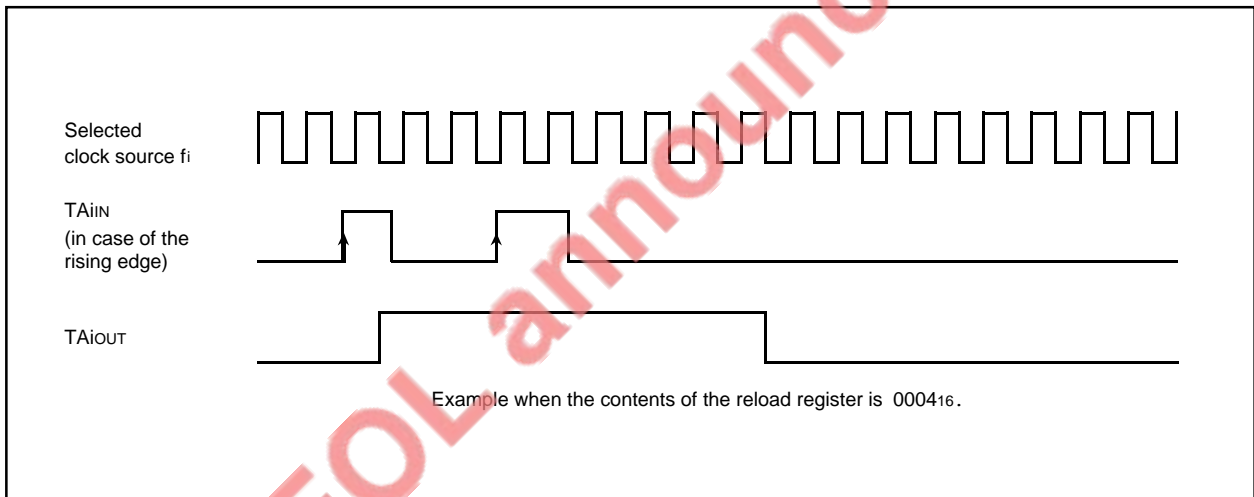

Fig. 23 Example when trigger is re-issued during pulse output

**M37702M2AXXFP, M37702M2BXXFP
M37702S1AFP, M37702S1BFP**

SINGLE-CHIP 16-BIT CMOS MICROCOMPUTER

(4) Pulse width modulation mode [11]

Figure 24 shows the bit configuration of the timer Ai mode register during pulse width modulation mode. In pulse width modulation mode, bits 0, 1, and 2 must be set to "1". Bit 5 is used to determine whether to perform 16-bit length pulse width modulator or 8-bit length pulse width modulator. 16-bit length pulse width modulator is performed when bit 5 is "0" and 8-bit length pulse width modulator is performed when it is "1". The 16-bit length pulse width modulator is described first.

The pulse width modulator can be started with a software trigger or with an input signal from a TAIiN pin (external trigger).

The software trigger mode is selected when bit 4 is "0". Pulse width modulator is started and pulse is output from TAIOUT when the timer Ai start flag is set to "1".

The external trigger mode is selected when bit 4 is "1". Pulse width modulator starts when a trigger signal is input from the TAIiN pin when the timer Ai start flag is "1". Whether to trigger at the fall or rise of the trigger signal is determined by bit 3. The trigger is at the fall of the trigger signal when bit 3 is "0" and at the rise when it is "1".

When data is written to timer Ai with the pulse width modulator halted, it is written to the reload register and the counter.

Then when the timer Ai start flag is set to "1" and a software trigger or an external trigger is issued to start modulation, the waveform shown in Figure 25 is output continuously. Once modulation is started, triggers are not accepted. If the value in the reload register is m, the duration "H" of pulse is

$$\frac{1}{\text{selected clock frequency}} \times m$$

and the output pulse period is

$$\frac{1}{\text{selected clock frequency}} \times (2^{16} - 1).$$

An interrupt request signal is generated and the interrupt request bit in the timer Ai interrupt control register is set at each fall of the output pulse.

The width of the output pulse is changed by updating timer data. The update can be performed at any time. The output pulse width is changed at the rise of the pulse after data is written to the timer. The contents of the reload register are transferred to the counter just before the rise of the next pulse so that the pulse width is changed from the next output pulse.

Undefined data is read when timer Ai is read.

The 8-bit length pulse width modulator is described next.

The 8-bit length pulse width modulator is selected when the timer Ai mode register bit 5 is "1".

The reload register and the counter are both divided into 8-bit halves.

The low order 8 bits function as a prescaler and the high order 8 bits function as the 8-bit length pulse width modulator. The prescaler counts the clock selected by bits 6 and 7. A pulse is generated when the counter reaches 0000₁₆ as shown in Figure 26. At the same time, the contents of the reload register is transferred to the counter and count is continued.

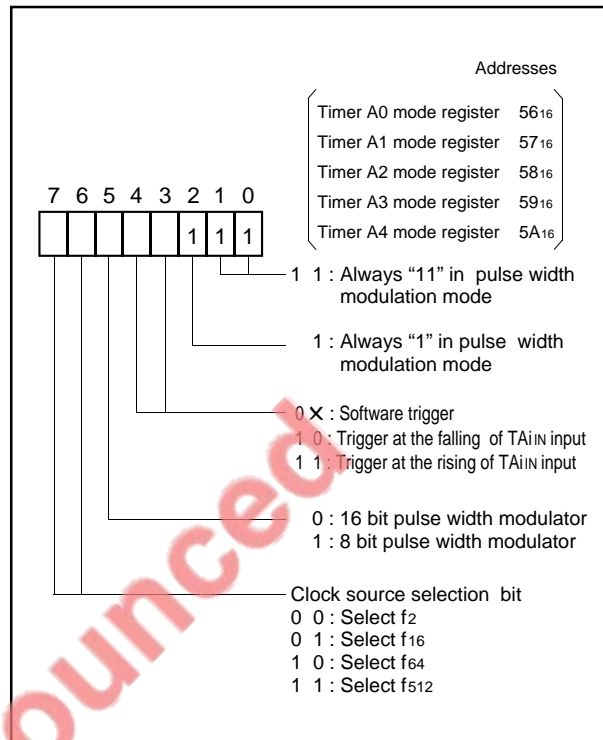

Fig. 24 Timer Ai mode register bit configuration during pulse width modulation mode

MITSUBISHI MICROCOMPUTERS

M37702M2AXXFP, M37702M2BXXFP M37702S1AFP, M37702S1BFP

SINGLE-CHIP 16-BIT CMOS MICROCOMPUTER

Therefore, if the low order 8-bit of the reload register is n, the period of the generated pulse is

$$\frac{1}{\text{selected clock frequency}} \times (n + 1).$$

The high order 8-bit function as an 8-bit length pulse width modulator using this pulse as input. The operation is the same as for 16-bit length pulse width modulator except that the length is 8 bits.

If the high order 8-bit of the reload register is m, the duration "H" of pulse is

$$\frac{1}{\text{selected clock frequency}} \times (n + 1) \times m.$$

And the output pulse period is

$$\frac{1}{\text{selected clock frequency}} \times (n + 1) \times (2^8 - 1).$$

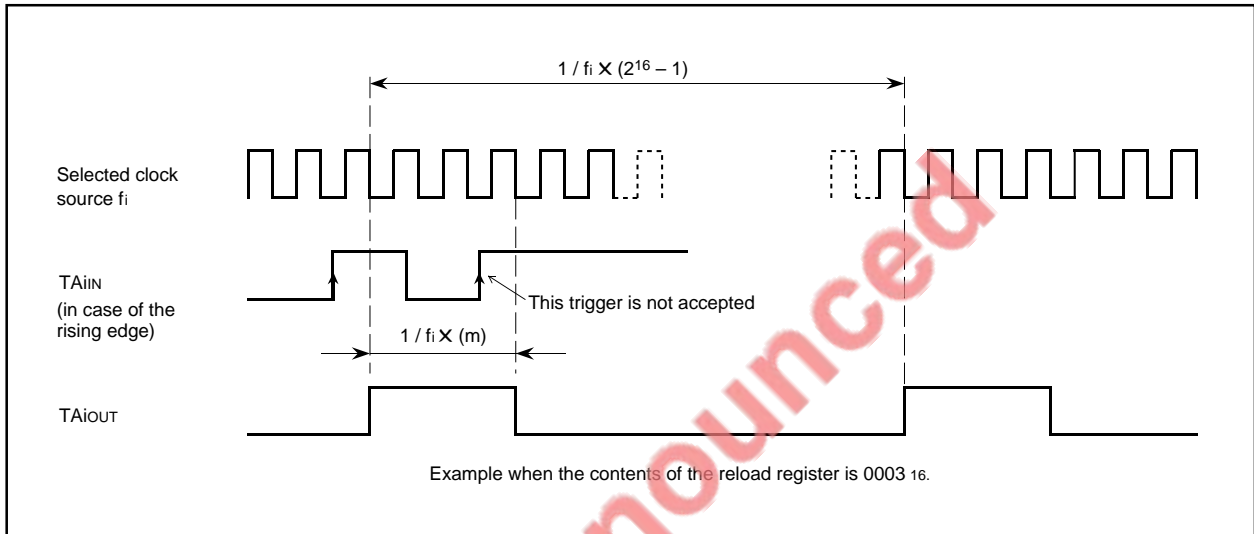

Fig. 25 16-bit length pulse width modulator output pulse example

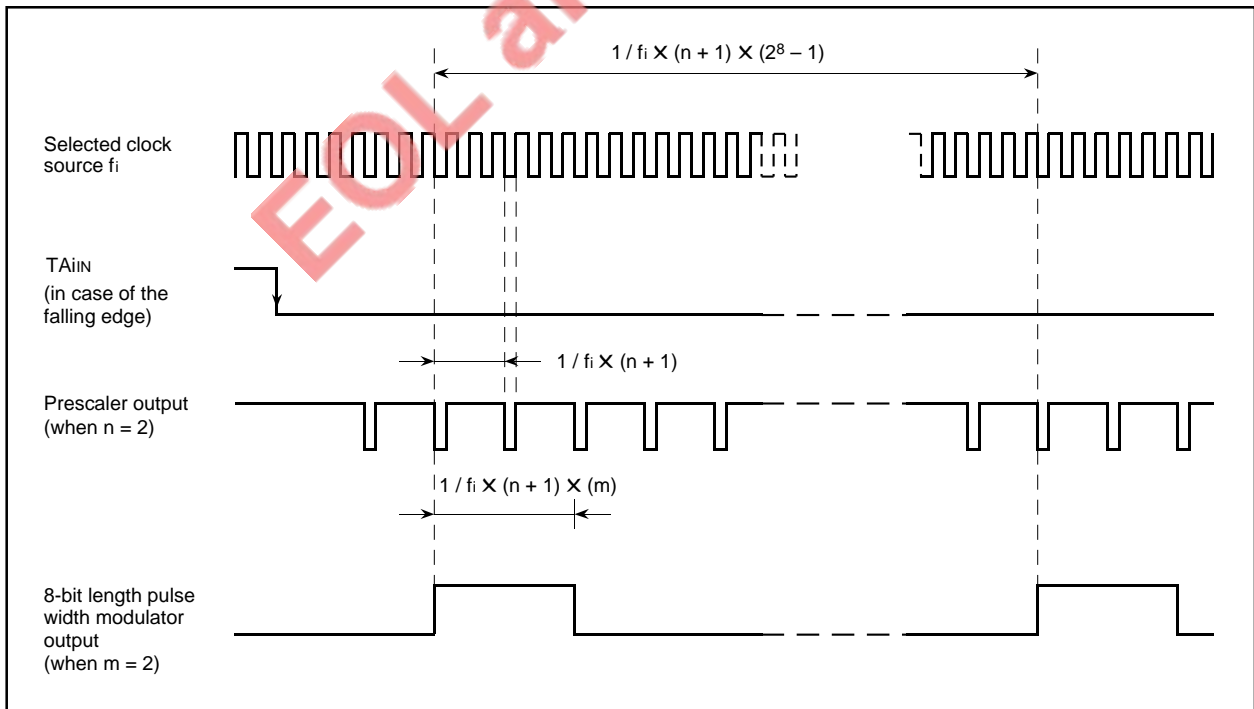

Fig. 26 8-bit length pulse width modulator output pulse example

TIMER B

Figure 27 shows a block diagram of timer B.

Timer B has three modes; timer mode, event counter mode, and pulse period measurement/pulse width measurement mode. The mode is selected with bits 0 and 1 of the timer Bi mode register (i = 0 to 2). Each of these modes is described below.

(1) Timer mode [00]

Figure 28 shows the bit configuration of the timer Bi mode register during timer mode. Bits 0, and 1 of the timer Bi mode register must always be "0" in timer mode.

Bits 6 and 7 are used to select the clock source. The counting of the selected clock starts when the count start flag is "1" and stops when "0".

As shown in Figure 13, the timer Bi count start flag is at the same address as the timer Ai count start flag. The count is decremented, an interrupt occurs, and the interrupt request bit in the timer Bi interrupt control register is set when the contents becomes 000016. At the same time, the contents of the reload register is stored in the counter and count is continued.

Timer Bi does not have a pulse output function or a gate function like timer A.

When data is written to timer Bi halted, it is written to the reload register and the counter. When data is written to timer Bi which is busy, the data is written to the reload register, but not to the counter. The counter is reloaded with new data from the reload register at the next reload time. The contents of the counter can be read at any time.

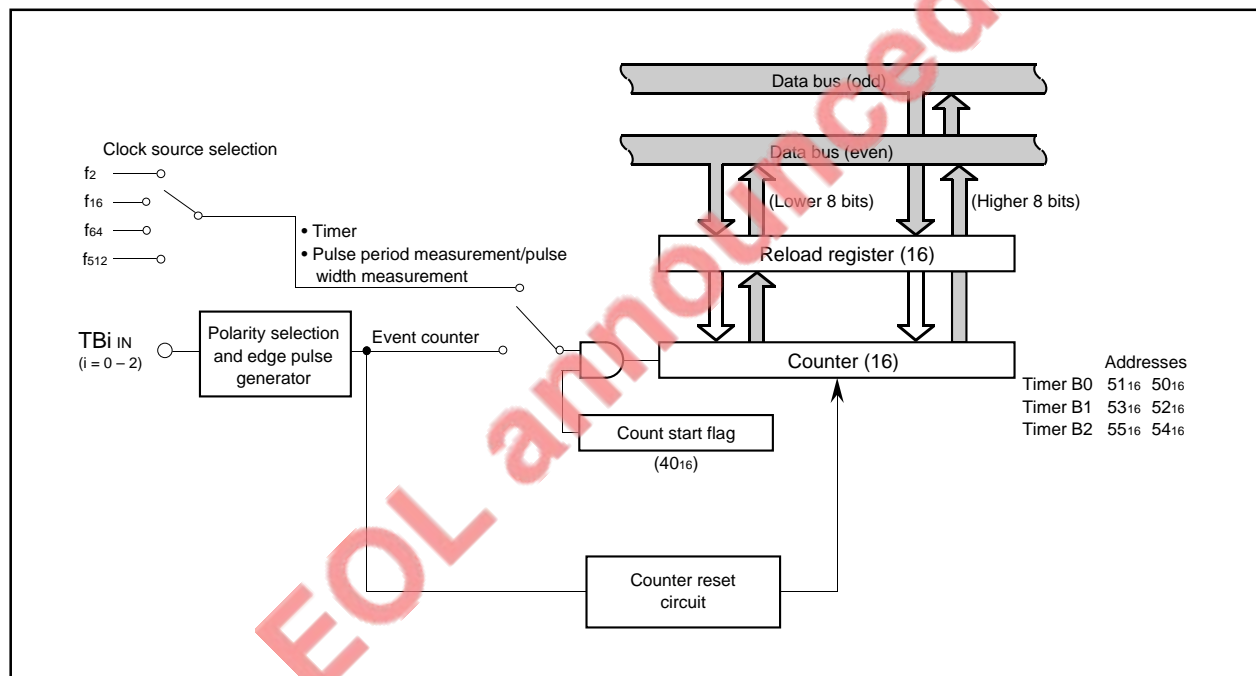

Fig. 27 Timer B block diagram

**M37702M2AXXFP, M37702M2BXXFP
M37702S1AFP, M37702S1BFP**

SINGLE-CHIP 16-BIT CMOS MICROCOMPUTER

(2) Event counter mode [01]

Figure 29 shows the bit configuration of the timer Bi mode register during event counter mode. In event counter mode, the bit 0 in the timer Bi mode register must be "1" and bit 1 must be "0".

The input signal from the TBiIN pin is counted when the count start flag is "1" and counting is stopped when it is "0". Count is performed at the fall of the input signal when bits 2, and 3 are "0" and at the rise of the input signal when bit 3 is "0" and bit 2 is "1".

When bit 3 is "1" and bit 2 is "0", count is performed at the rise and fall of the input signal.

Data write, data read and timer interrupt are performed in the same way as for timer mode.

(3) Pulse period measurement/pulse width measurement mode [10]

Figure 30 shows the bit configuration of the timer Bi mode register during pulse period measurement/pulse width measurement mode.

In pulse period measurement/pulse width measurement mode, bit 0 must be "0" and bit 1 must be "1". Bits 6 and 7 are used to select the clock source. The selected clock is counted when the count start flag is "1" and counting stops when it is "0".

The pulse period measurement mode is selected when bit 3 is "0".

In pulse period measurement mode, the selected clock is counted during the interval starting at the fall of the input signal from the TBiIN pin to the next fall or at the rise of the input signal to the next rise and the result is stored in the reload register. In this case, the reload register acts as a buffer register.

When bit 2 is "0", the clock is counted from the fall of the input signal to the next fall. When bit 2 is "1", the clock is counted from the rise of the input signal to the next rise.

In the case of counting from the fall of the input signal to the next fall, counting is performed as follows. As shown in Figure 31, when the fall of the input signal from TBiIN pin is detected, the contents of the counter is transferred to the reload register. Next the counter is cleared and count is started from the next clock. When the fall of the next input signal is detected, the contents of the counter is transferred to the reload register once more, the counter is cleared, and the count is started. The period from the fall of the input signal to the next fall is measured in this way.

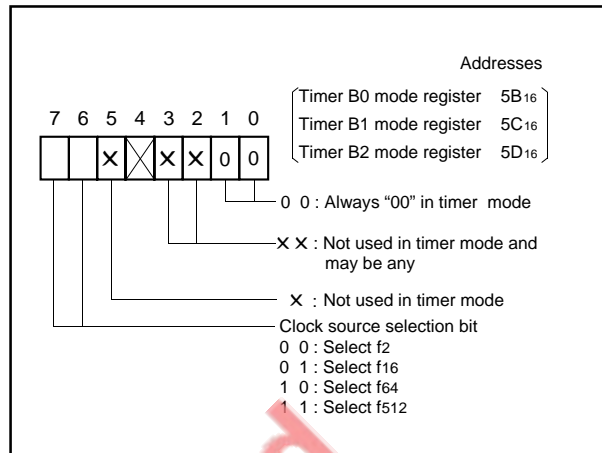

Fig. 28 Timer Bi mode register bit configuration during timer mode

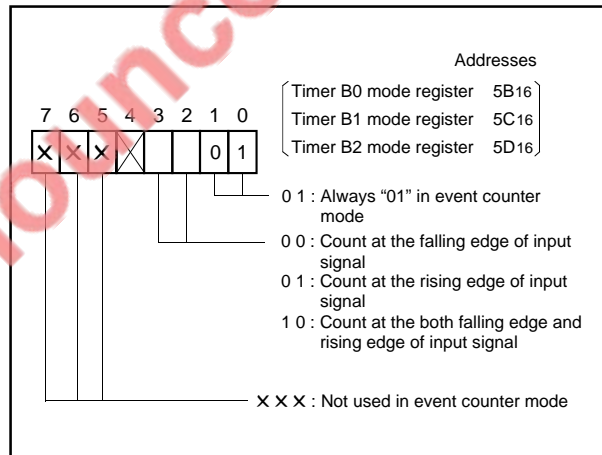

Fig. 29 Timer Bi mode register bit configuration during event counter mode

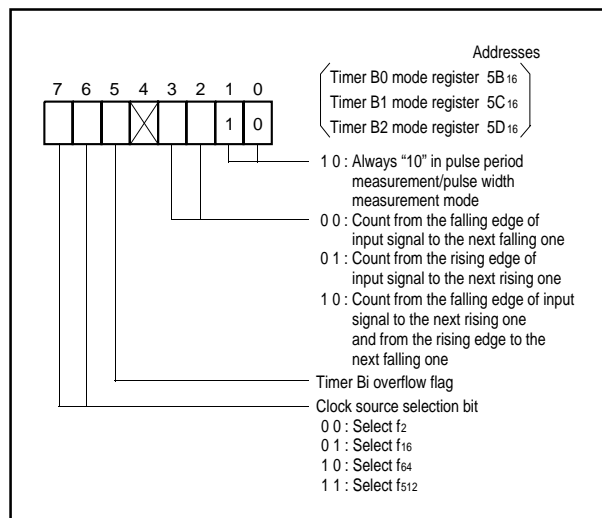

Fig. 30 Timer Bi mode register bit configuration during pulse period measurement/pulse width measurement mode

**M37702M2AXXFP, M37702M2BXXFP
M37702S1AFP, M37702S1BFP**

SINGLE-CHIP 16-BIT CMOS MICROCOMPUTER

After the contents of the counter is transferred to the reload register, an interrupt request signal is generated and the interrupt request bit in the timer Bi interrupt control register is set. However, no interrupt request signal is generated when the contents of the counter is transferred first time to the reload register after the count start flag is set to "1".

When bit 3 is "1", the pulse width measurement mode is selected. Pulse width measurement mode is similar to pulse period measurement mode except that the clock is counted from the fall of the TBiIn pin input signal to the next rise or from the rise of the input

signal to the next fall as shown in Figure 32.

When timer Bi is read, the contents of the reload register is read.

Note that in this mode, the interval between the fall of the TBiIn pin input signal to the next rise or from the rise to the next fall must be at least two cycles of the timer count source.

Timer Bi overflow flag which is bit 5 of time Bi mode register is set to "1" when the timer Bi counter reaches 0000₁₆.

This flag is cleared by writing to corresponding timer Bi mode register. This bit is set to "1" at reset.

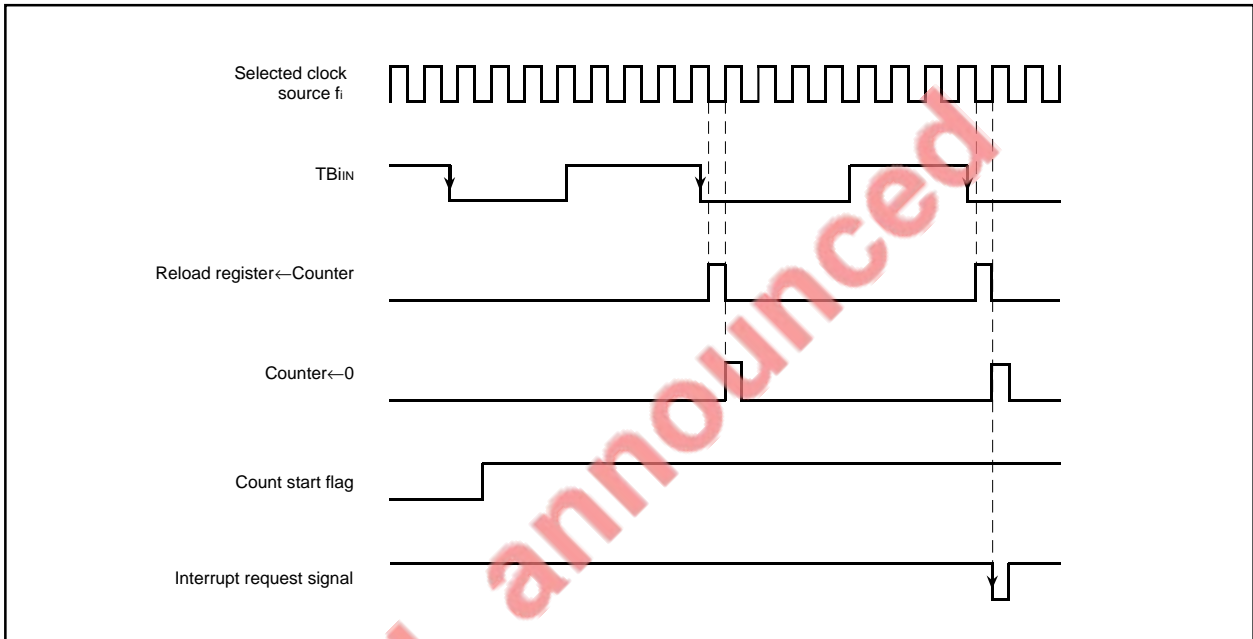

Fig. 31 Pulse period measurement mode operation (example of measuring the interval between the falling edge to next falling one)

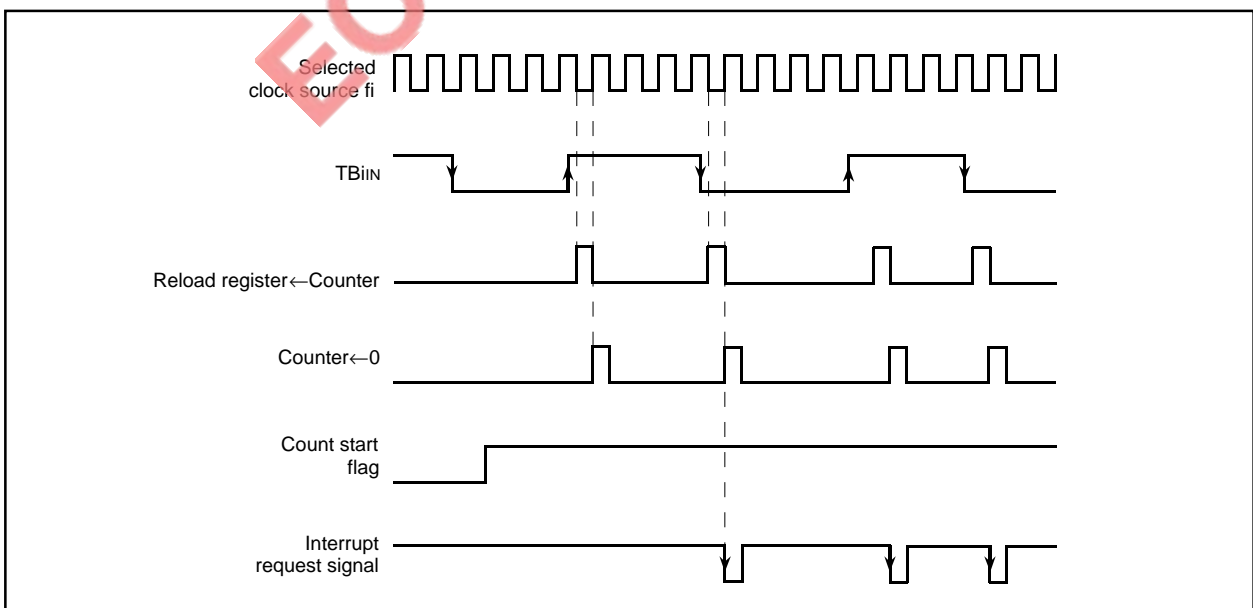

Fig. 32 Pulse width measurement mode operation

M37702M2AXXFP, M37702M2BXXFP M37702S1AFP, M37702S1BFP

SINGLE-CHIP 16-BIT CMOS MICROCOMPUTER

SERIAL I/O PORTS

Two independent serial I/O ports are provided. Figure 33 shows a block diagram of the serial I/O ports. Bits 0, 1, and 2 of the UART_i (i = 0, 1) Transmit/Receive mode register shown in Figure 34 are used to determine whether to use port P8 as parallel port, clock synchronous serial I/O port, or asynchro-

nous (UART) serial I/O port using start and stop bits. Figures 35 and 36 show the connections of receiver/transmitter according to the mode. Figure 37 shows the bit configuration of the UART_i transmit/receive control register. Each communication method is described below.

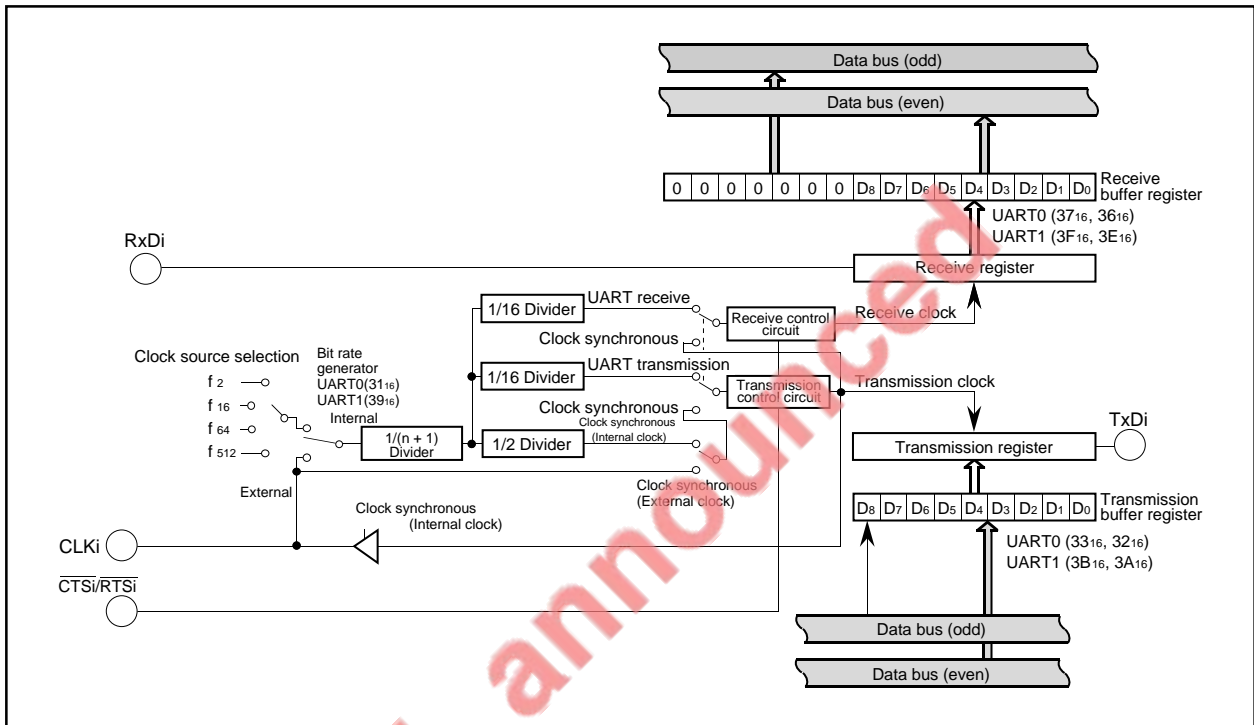

Fig. 33 Serial I/O port block diagram

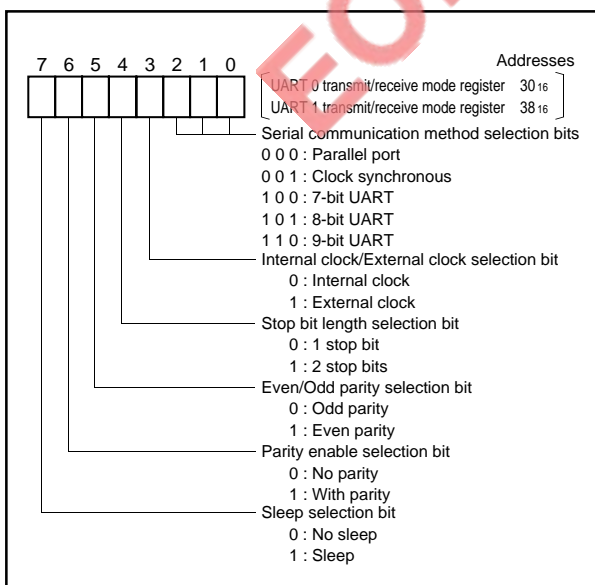

Fig. 34 UART i Transmit/Receive mode register bit configuration

MITSUBISHI MICROCOMPUTERS
M37702M2AXXFP, M37702M2BXXFP
M37702S1AFP, M37702S1BFP

SINGLE-CHIP 16-BIT CMOS MICROCOMPUTER

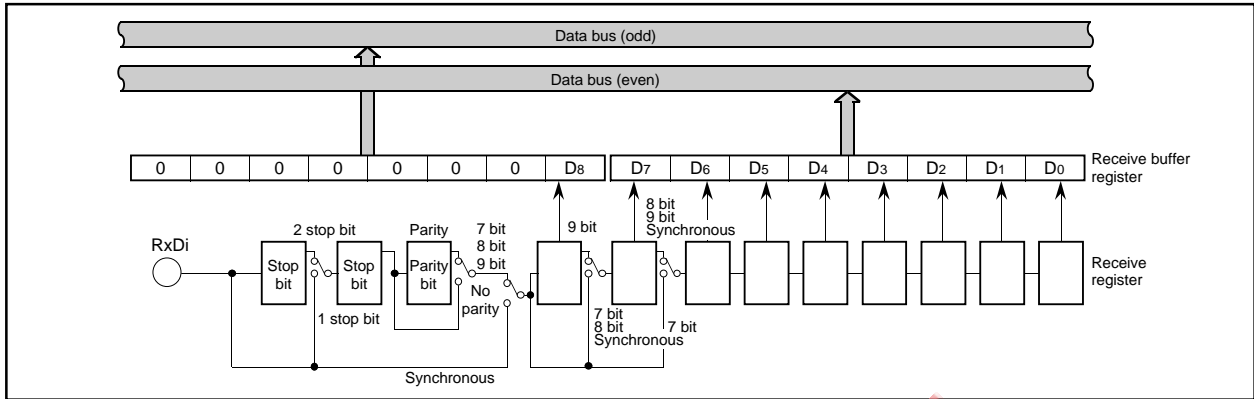

Fig. 35 Receiver block diagram

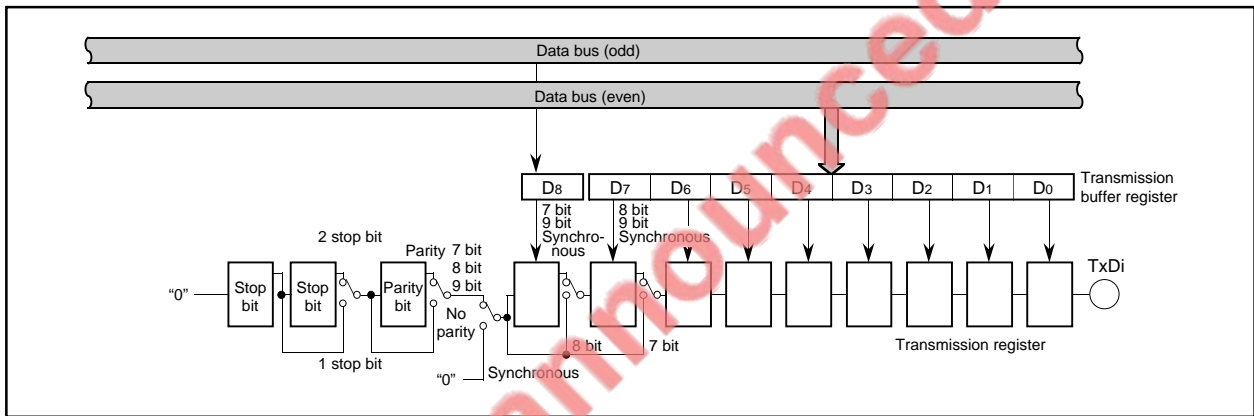

Fig. 36 Transmitter block diagram

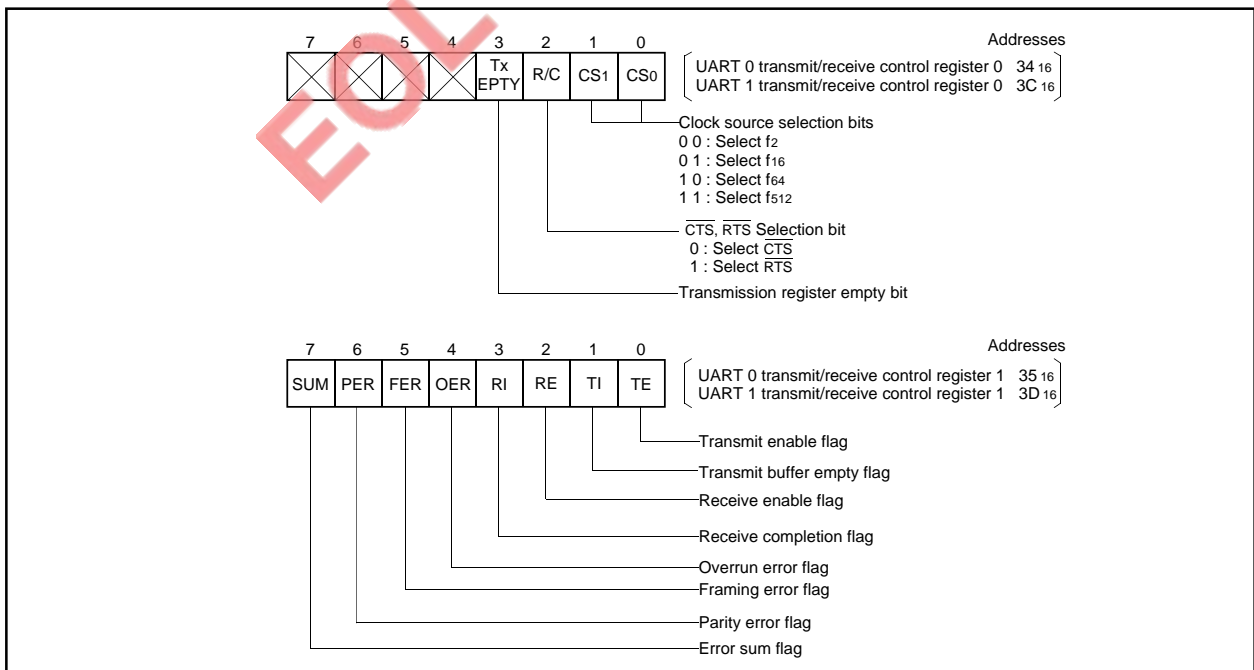

Fig. 37 UARTi Transmit/Receive control register bit configuration

M37702M2AXXFP, M37702M2BXXFP M37702S1AFP, M37702S1BFP

SINGLE-CHIP 16-BIT CMOS MICROCOMPUTER

CLOCK SYNCHRONOUS SERIAL COMMUNICATION

A case where communication is performed between two clock synchronous serial I/O ports as shown in Figure 38 will be described. (The transmission side will be denoted by subscript j and the receiving side will be denoted by subscript k.)

Bit 0 of the UARTj transmit/receive mode register and UARTk transmit/receive mode register must be set to "1" and bits 1 and 2 must be "0". The length of the transmission data is fixed at 8 bits.

Bit 3 of the UARTj transmit/receive mode register of the clock sending side is cleared to "0" to select the internal clock. Bit 3 of the UARTk transmit/receive mode register of the clock receiving side is set to "1" to select the external clock. Bits 4, 5 and 6 are ignored in clock synchronous mode. Bit 7 must always be "0".

The clock source is selected by bit 0 (CS0) and bit 1 (CS1) of the clock sending side UARTj transmit/receive control register 0. As shown in Figure 33, the selected clock is divided by (n + 1), then by 2, passed through a transmission control circuit, and output as transmission clock CLKj. Therefore, when the selected clock is fi,

$$\text{Bit Rate} = f_i / \{(n + 1) \times 2\}$$

On the clock receiving side, the CS0 and CS1 bits of the UARTk transmit/receive control register 0 are ignored because an external clock is selected.

The bit 2 of the clock sending side UARTj transmit/receive control register 0 is clear to "0" to select CTSj input. The bit 2 of the clock receiving side is set to "1" to select RTSk output. CTS, and RTS signals are described later.

Transmission

Transmission is started when the bit 0 (TEj flag) of UARTj transmit/receive control register 1 is "1", bit 1 (Tlj flag) of one is "0", and CTSj input is "L". As shown in Figure 39, data is output from TxDj pin when transmission clock CLKj changes from "H" to "L". The data is output from the least significant bit.

The Tlj flag indicates whether the transmission buffer register is empty or not. It is cleared to "0" when data is written in the transmission buffer register and set to "1" when the contents of the transmission buffer register is transferred to the transmission register.

When the transmission register becomes empty after the contents has been transmitted, data is transferred automatically from the transmission buffer register to the transmission register if the next transmission start condition is satisfied. If the bit 2 of UARTj transmit/receive control register 0 is "1", CTSj input is ignored and transmission start is controlled only by the TEj flag and Tlj flag. Once transmission has started, the TEj flag, Tlj flag, and CTSj signals are ignored until data transmission completes. Therefore, transmission is not interrupt when CTSj input is changed to "H" during transmission.

The transmission start condition indicated by TEj flag, Tlj flag, and CTSj is checked while the TENDj signal shown in Figure 39 is "H". Therefore, data can be transmitted continuously if the next transmission data is written in the transmission buffer register and Tlj flag is cleared to "0" before the TENDj signal goes "H".

The bit 3 (TxEPTYj flag) of UARTj transmit/receive control register 0 changes to "1" at the next cycle after the TENDj signal goes "H" and changes to "0" when transmission starts. Therefore, this flag can be used to determine whether data transmission has completed.

When the Tlj flag changes from "0" to "1", the interrupt request bit in the UARTj transmission interrupt control register is set to "1".

Receive

Receive starts when the bit 2 (REk flag) of UARTk transmit/receive control register 1 is set to "1".

The RTSk output is "H" when the REk flag is "0" and goes "L" when the REk flag changed to "1". It goes back to "H" when receive starts. Therefore, the RTSk output can be used to determine whether the receive register is ready to receive. It is ready when RTSk output is "L".

The data from the RxDk pin is retrieved and the contents of the receive register is shifted by 1 bit each time the transmission clock CLKj changes from "L" to "H". When an 8-bit data is received, the contents of the receive register is transferred to the receive buffer register and the bit 3 (Rlk flag) of UARTk transmit/receive control register 1 is set to "1". In other words, the setting of the Rlk flag indicates that the receive buffer register contains the received data. At this point, RTSj output goes "L" to indicate that the next data can be received. When the Rlk flag changes from "0" to "1", the interrupt request bit in the UARTk receive interrupt control register is set to "1". Bit 4 (OERk flag) of UARTk transmit/receive control register is set to "1" when the next data is transferred from the receive register to the receive buffer register while Rlk flag is "1", and indicates that the next data was transferred to the receive register before the contents of the receive buffer register was read.

Rlk and OERk flags are cleared automatically to "0" when the low-order byte of the receive buffer register is read. The OERk flag is also cleared when the REk flag is cleared. Bit 5 (FERk flag), bit 6 (PERk flag), and bit 7 (SUMk flag) are ignored in clock synchronous mode.

As shown in Figure 33, with clock synchronous serial communication, data cannot be received unless the transmitter is operating because the receive clock is created from the transmission clock. Therefore, the transmitter must be operating even when there is no data to be sent from UARTk to UARTj.

MITSUBISHI MICROCOMPUTERS
M37702M2AXXFP, M37702M2BXXFP
M37702S1AFP, M37702S1BFP

SINGLE-CHIP 16-BIT CMOS MICROCOMPUTER

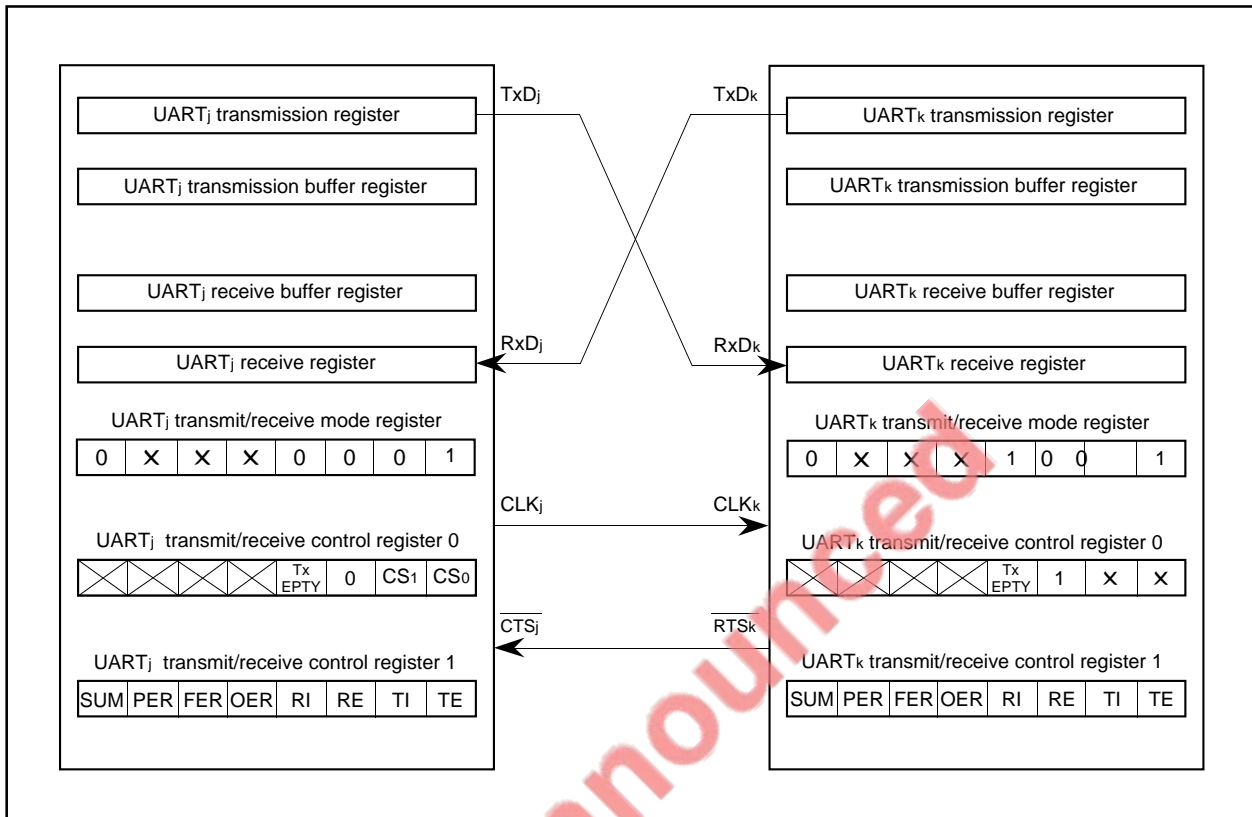

Fig. 38 Clock synchronous serial communication

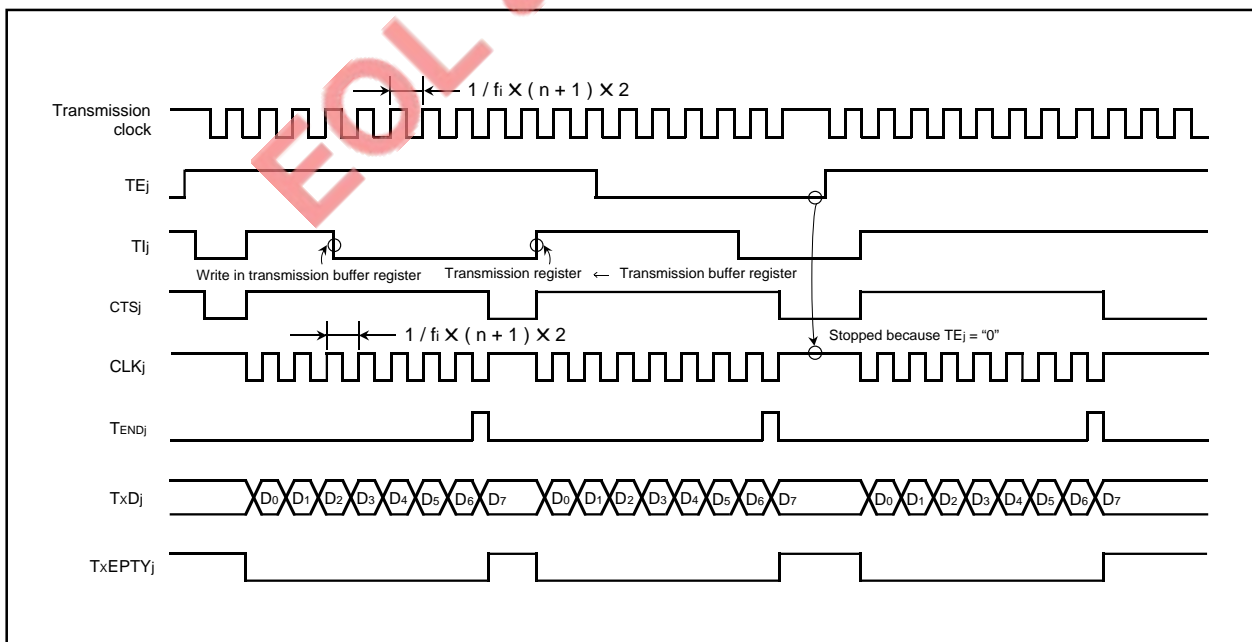

Fig. 39 Clock synchronous serial I/O timing

MITSUBISHI MICROCOMPUTERS

M37702M2AXXFP, M37702M2BXXFP M37702S1AFP, M37702S1BFP

SINGLE-CHIP 16-BIT CMOS MICROCOMPUTER

ASYNCHRONOUS SERIAL COMMUNICATION

Asynchronous serial communication can be performed using 7-, 8-, or 9-bit length data. The operation is the same for all data lengths. The following is the description for 8-bit asynchronous communication.

With 8-bit asynchronous communication, the bit 0 of UART_i transmit/receive mode register is "1", the bit 1 is "0", and the bit 2 is "1". Bit 3 is used to select an internal clock or an external clock. If bit 3 is "0", an internal clock is selected and if bit 3 is "1", then external clock is selected. If an internal clock is selected, the bit 0 (CS₀) and bit 1 (CS₁) of UART_i transmit/receive control register 0 are used to select the clock source. When an internal clock is selected for asynchronous serial communication, the CLK_i pin can be used as a normal I/O pin.

The selected internal or external clock is divided by (n + 1), then by 16, and passed through a control circuit to create the UART transmission clock or UART receive clock.

Therefore, the transmission speed can be changed by changing the contents n of the bit rate generator. If the selected clock is an internal clock f_i or an external clock f_{EXT},

$$\text{Bit Rate} = (f_i \text{ or } f_{EXT}) / \{(n + 1) \times 16\}$$

Bit 4 is the stop bit length selection bit to select 1 stop bit or 2 stop bits.

The bit 5 is a selection bit of odd parity or even parity.

In the odd parity mode, the parity bit is adjusted so that the sum of the 1's in the data and parity bit is always odd.

In the even parity mode, the parity bit is adjusted so that the sum of the 1's in the data and parity bit is always even.

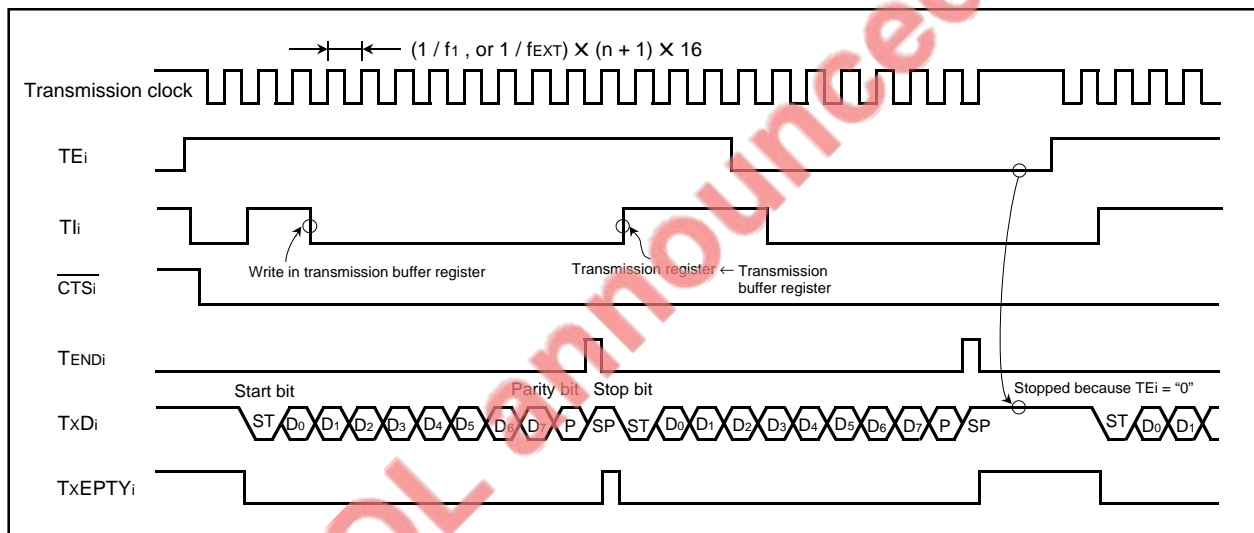

Fig. 40 Transmit timing example when 8-bit asynchronous communication with parity and 1 stop bit is selected

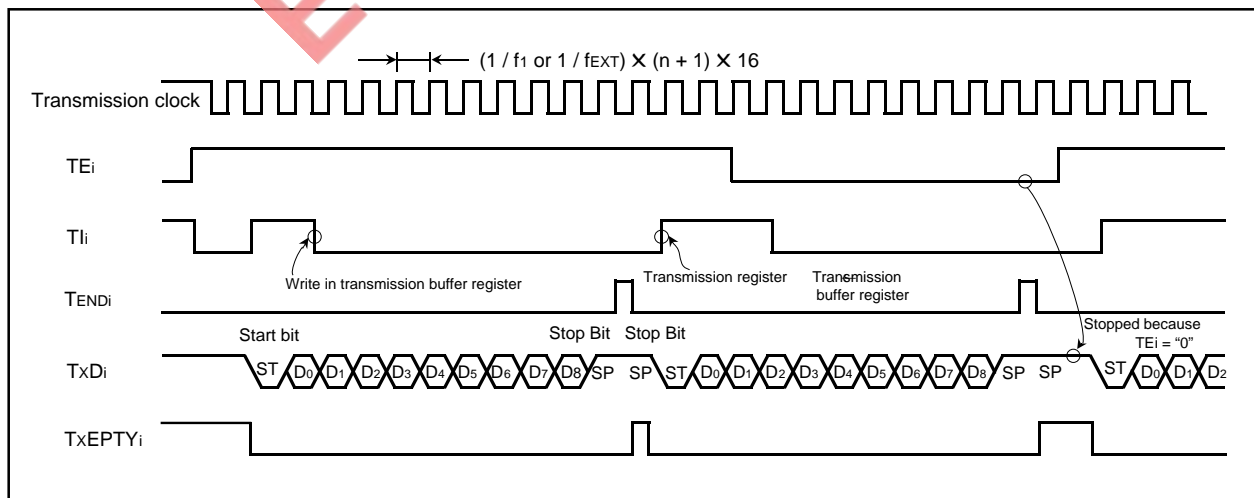

Fig. 41 Transmit timing example when 9-bit asynchronous communication with no parity and 2 stop bits is selected

MITSUBISHI MICROCOMPUTERS

M37702M2AXXFP, M37702M2BXXFP M37702S1AFP, M37702S1BFP

SINGLE-CHIP 16-BIT CMOS MICROCOMPUTER

Bit 6 is the parity bit selection bit which indicates whether to add parity bit or not.

Bits 4 to 6 should be set or reset according to the data format of the communicating devices.

Bit 7 is the sleep selection bit. The sleep mode is described later. The UART_i transmit/receive control register 0 bit 2 is used to determine whether to use CTS_i input or RTS_i output.

CTS_i input is used if bit 2 is "0" and RTS_i output is used if bit 2 is "1".

If CTS_i input is selected, the user can control whether to stop or start transmission by external CTS_i input. RTS_i will be described later.

Transmission

Transmission is started when the bit 0 (TE_i flag) of UART_i transmit/receive control register 1 is "1", the bit 1 (TI_i flag) is "0", and CTS_i input is "L" if CTS_i input is selected. As shown in Figure 40 and 41, data is output from the TxD_i pin with the stop bit and parity bit specified by the bits 4 to 6 of UART_i transmit/receive mode register. The data is output from the least significant bit.

The TI_i flag indicates whether the transmission buffer is empty or not. It is cleared to "0" when data is written in the transmission buffer and set to "1" when the contents of the transmission buffer register is transferred to the transmission register.

When the transmission register becomes empty after the contents has been transmitted, data is transferred automatically from the transmission buffer register to the transmission register if the next transmission start condition is satisfied.

Once transmission has started, the TE_i flag, TI_i flag, and CTS_i signal (if CTS_i input is selected) are ignored until data transmission is completed.

Therefore, transmission does not stop until it completes even if the TE_i flag is cleared during transmission.

The transmission start condition indicated by TE_i flag, TI_i flag, and CTS_i is checked while the TEND_i signal shown in Figure 40 is "H". Therefore, data can be transmitted continuously if the next transmission data is written in the transmission buffer register and TI_i flag is cleared to 0 before the TEND_i signal goes "H".

The bit 3 (TxEMPTY_i flag) of UART_i transmit/receive control register 0 changes to "1" at the next cycle after the TEND_i signal goes "H" and changes to "0" when transmission starts. Therefore, this flag can be used to determine whether data transmission is completed. When the TI_i flag changes from "0" to "1", the interrupt request bit in the UART_i transmission interrupt control register is set to "1".

Receive

Receive is enabled when the bit 2 (RE_i flag) of UART_i transmit/receive control register 1 is set. As shown in Figure 42, the frequency divider circuit at the receiving end begin to work when a start bit is arrived and the data is received.

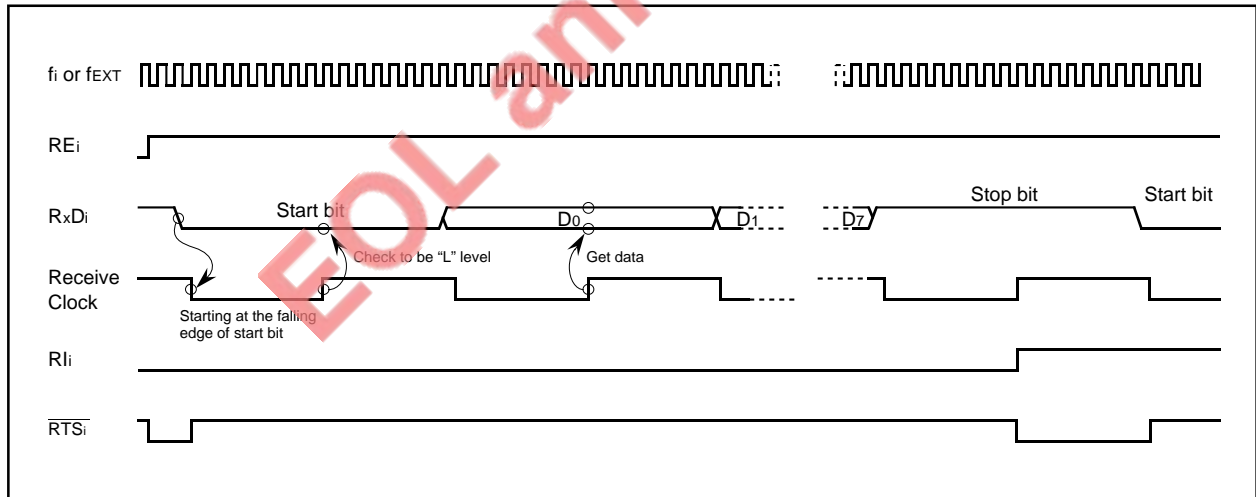

Fig. 42 Receive timing example when 8-bit asynchronous communication with no parity and 1 stop bit is selected.

**M37702M2AXXFP, M37702M2BXXFP
M37702S1AFP, M37702S1BFP**

SINGLE-CHIP 16-BIT CMOS MICROCOMPUTER

If \overline{RTSi} output is selected by setting the bit 2 of $UART_i$ transmit/receive control register 0 to "1", the $RTSi$ output is "H" when the RE_i flag is "0". When the RE_i flag changes to "1", the $RTSi$ output goes "L" to indicate receive ready and returns to "H" once receive has started. In other words, \overline{RTSi} output can be used to determine externally whether the receive register is ready to receive.

The entire transmission data bits are received when the start bit passes the final bit of the receive block shown in Figure 35. At this point, the contents of the receive register is transferred to the receive buffer register and the bit 3 of $UART_i$ transmit/receive control register 1 is set. In other words, the Rli flag indicates that the receive buffer register contains data when it is set. If $RTSi$ output is selected, $RTSi$ output goes "L" to indicate that the register is ready to receive the next data.

The interrupt request bit in the $UART_i$ receive interrupt control register is set when the Rli flag changes from "0" to "1".

The bit 4 (OER_i flag) of $UART_i$ transmission control register 1 is set when the next data is transferred from the receive register to the receive buffer register while the Rli flag is "1". In other words when an overrun error occurs. If the OER_i flag is "1", it indicates that the next data has been transferred to the receive buffer register before the contents of the receive buffer register has been read.

Bit 5 (FER_i flag) is set when the number of stop bits is less than required (framing error).

Bit 6 (PER_i flag) is set when a parity error occurs.

Bit 7 (SUM_i flag) is set when either the OER_i flag, FER_i flag, or the PER_i flag is set. Therefore, the SUM_i flag can be used to determine whether there is an error.

The setting of the Rli flag, OER_i flag, FER_i flag, and the PER_i flag is performed while transferring the contents of the receive register to the receive buffer register. The Rli , OER_i , FER_i , PER_i , and SUM_i flags are cleared when the low order byte of the receive buffer register is read or when the RE_i flag is cleared.

Sleep mode

The sleep mode is used to communicate only between certain microcomputers when multiple microcomputers are connected through serial I/O.

The sleep mode is entered when the bit 7 of $UART_i$ transmit/receive mode register is set.

The operation of the sleep mode for an 8-bit asynchronous communication is described below.

When sleep mode is selected, the contents of the receive register is not transferred to the receive buffer register if bit 7 (bit 6 if 7-bit asynchronous communication and bit 8 if 9-bit asynchronous communication) of the received data is "0". Also the Rli , OER_i , FER_i , PER_i , and the SUM_i flag are unchanged. Therefore, the interrupt request bit of the $UART_i$ receive interrupt control register is also unchanged.

Normal receive operation takes place when bit 7 of the received data is "1".

The following is an example of how the sleep mode can be used.

The main microcomputer first sends data with bit 7 set to "1" and bits 0 to 6 set to the address of the subordinate microcomputer which wants to communicate with. Then all subordinate microcom-

puters receive the same data. Each subordinate microcomputer checks the received data, clears the sleep bit if bits 0 to 6 are its own address and sets the sleep bit if not. Next the main microcomputer sends data with bit 7 cleared. Then the microcomputer with the sleep bit cleared will receive the data, but the microcomputer with the sleep bit set will not. In this way, the main microcomputer is able to communicate with only the designated microcomputer.

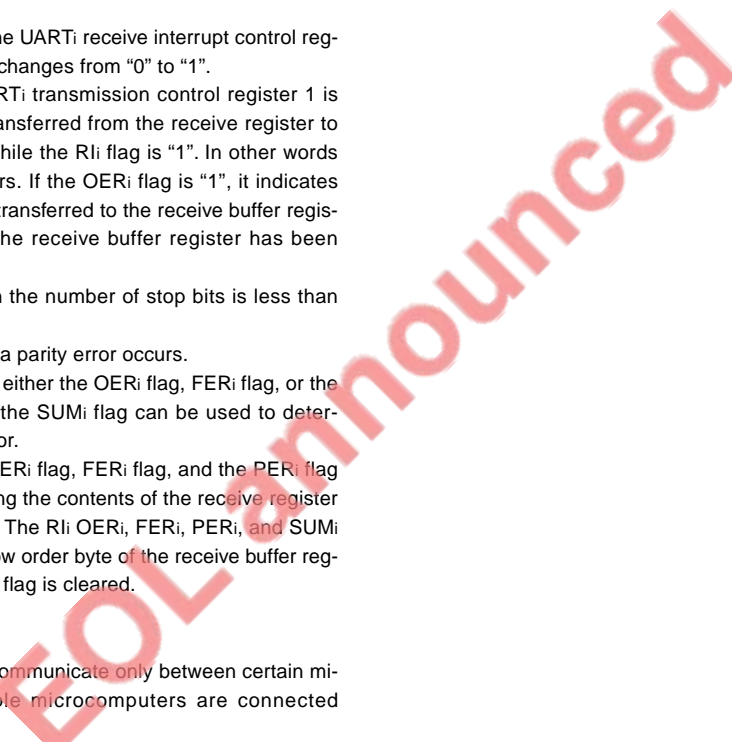

**M37702M2AXXFP, M37702M2BXXFP
M37702S1AFP, M37702S1BFP**

SINGLE-CHIP 16-BIT CMOS MICROCOMPUTER

A-D CONVERTER

The A-D converter is an 8-bit successive approximation converter. Figure 43 shows a block diagram of the A-D converter and Figure 44 shows the bit configuration of the A-D control register. The frequency of the A-D converter operating clock ϕ_{AD} is selected by the bit 7 of the A-D control register. When bit 7 is "0", ϕ_{AD} is the clock frequency divided by 8. That is, $\phi_{AD} = f(X_{IN})/8$. When bit 7 is "1", ϕ_{AD} is the clock frequency divided by 4 and ϕ_{AD} is = $f(X_{IN})/4$. The ϕ_{AD} during A-D conversion must be 250 kHz minimum because the comparator consists of a capacity coupling amplifier.

The operating mode is selected by the bits 3 and 4 of A-D control register. The available operating modes are one-shot, repeat, single sweep, and repeat sweep.

The bit of data direction register bit corresponding to the A-D converter pin must be "0" (input mode) because the analog input port is shared with port P7.

The operation of each mode is described below.

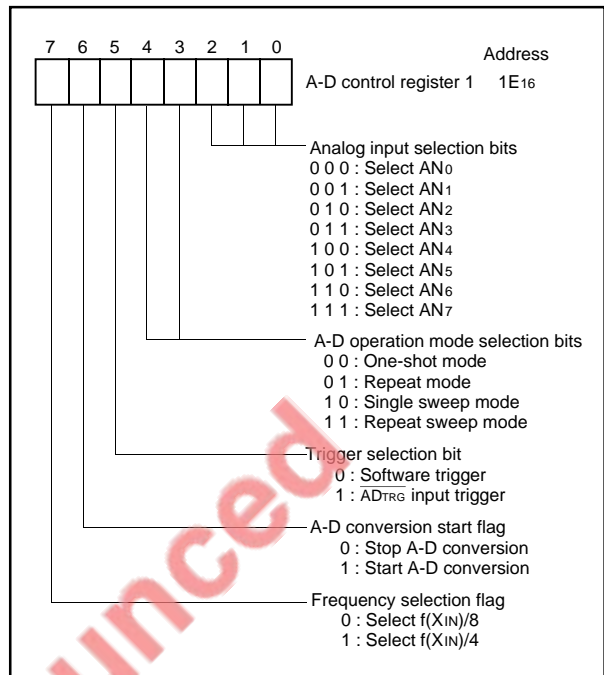

Fig 44 A-D control register bit configuration

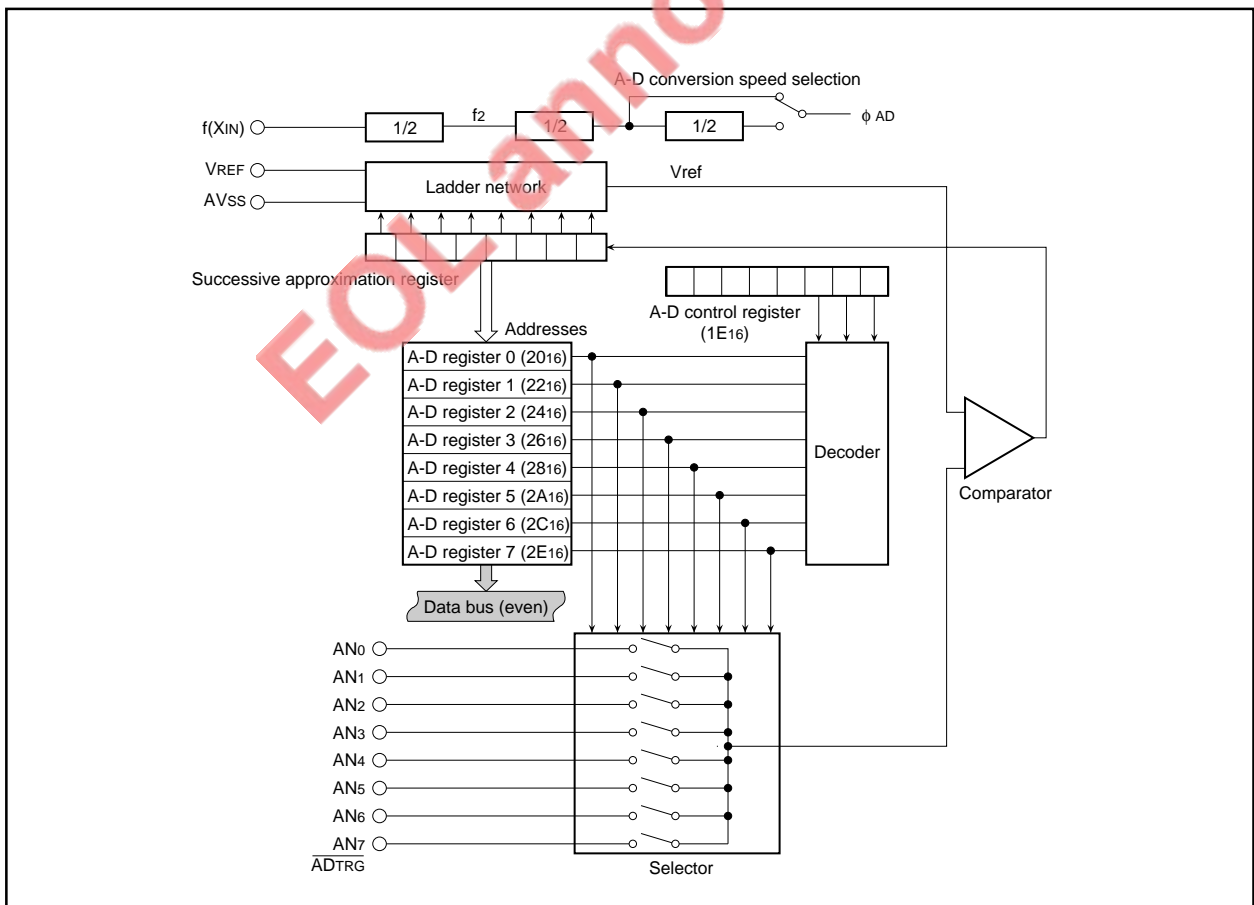

Fig 43 A-D converter block diagram

**M37702M2AXXFP, M37702M2BXXFP
M37702S1AFP, M37702S1BFP**

SINGLE-CHIP 16-BIT CMOS MICROCOMPUTER

(1) One-shot mode [00]

The A-D conversion pins are selected with the bit 0 to 2 of A-D control register. A-D conversion can be started by a software trigger or by an external trigger.

A software trigger is selected when the bit 5 of A-D control register is "0" and an external trigger is selected when it is "1".

When a software trigger is selected, A-D conversion is started when bit 6 (A-D conversion start flag) is set. A-D conversion ends after 57 ϕ_{AD} cycles and an interrupt request bit is set in the A-D conversion interrupt control register. At the same time, A-D control register bit 6 (A-D conversion start flag) is cleared and A-D conversion stops. The result of A-D conversion is stored in the A-D register corresponding to the selected pin.

If an external trigger is selected, A-D conversion starts when the A-D conversion start flag is "1" and the \overline{ADTRG} input changes from "H" to "L". In this case, the pins that can be used for A-D conversion are AN0 to AN6 because the \overline{ADTRG} pin is shared with the analog voltage input pin AN7. The operation is the same as with software trigger except that the A-D conversion start flag is not cleared after A-D conversion and a retrigger can be available during A-D conversion.

(2) Repeat mode [01]

The operation of this mode is the same as the operation of one-shot mode except that when A-D conversion of the selected pin is complete and the result is stored in the A-D register, conversion does not stop, but is repeated. Also, no interrupt request is issued in this mode. Furthermore, if software trigger is selected, the A-D conversion start flag is not cleared. The contents of the A-D register can be read at any time.

(3) Single sweep mode [10]

In the sweep mode, the number of analog input pins to be swept can be selected. Analog input pins are selected by bits 1 and 0 of the A-D sweep pin selection register (1F₁₆ address) shown in Figure 45. Two pins, four pins, six pins, or eight pins can be selected as analog input pins, depending on the contents of these bits.

A-D conversion is performed only for selected input pins. After A-D conversion is performed for input of AN0 pin, the conversion result is stored in A-D register 0, and in the same way, A-D conversion is performed for selected pins one after another. After A-D conversion is performed for all selected pins, the sweep is stopped.

A-D conversion can be started with a software trigger or with an external trigger input. A software trigger is selected when bit 5 is "0" and an external trigger is selected when it is "1".

When a software trigger is selected, A-D conversion is started when A-D control register bit 6 (A-D conversion start flag) is set. When A-D conversion of all selected pins end, an interrupt request bit is set in the A-D conversion interrupt control register. At the same time, A-D control register bit 6 (A-D conversion start flag) is cleared and A-D conversion stops.

When an external trigger is selected, A-D conversion starts when the A-D conversion start flag is "1" and the \overline{ADTRG} input changes from "H" to "L". In this case, the A-D conversion result of the trigger input itself is stored in the A-D register 7 because the \overline{ADTRG} pin is shared with AN7 pin.

The operation is the same as done by software trigger except that the A-D conversion start flag is not cleared after A-D conversion and a retrigger can be available during A-D conversion.

(4) Repeat sweep mode [11]

The difference with the single sweep mode is that A-D conversion does not stop after converting from the AN0 pin to the selected pins, but repeats again from the AN0 pin. The repeat is performed among the selected pins. Also, no interrupt request is generated. Furthermore, if software trigger is selected, the A-D conversion start flag is not cleared. The A-D register can be read at any time.

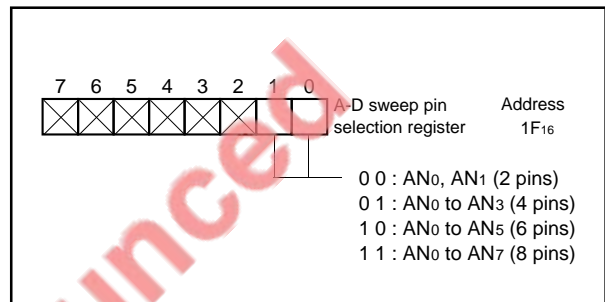

Fig. 45 A-D sweep pin selection register configuration

**M37702M2AXXFP, M37702M2BXXFP
M37702S1AFP, M37702S1BFP**

SINGLE-CHIP 16-BIT CMOS MICROCOMPUTER

WATCHDOG TIMER

The watchdog timer is used to detect unexpected execution sequence caused by software run-away.

Figure 46 shows a block diagram of the watchdog timer. The watchdog timer consists of a 12-bit binary counter.

The watchdog timer counts the clock frequency divided by 32 (f_{32}) or by 512 (f_{512}). Whether to count f_{32} or f_{512} is determined by the watchdog timer frequency selection flag shown in Figure 47. f_{512} is selected when the flag is "0" and f_{32} is selected when it is "1". The flag is cleared after reset. FFF_{16} is set in the watchdog timer when "L" or $2V_{CC}$ is applied to the \overline{RESET} pin, STP instruction is executed, data is written to the watchdog timer, or the most significant bit of the watchdog timer become "0".

After FFF_{16} is set in the watchdog timer, the contents of watchdog timer is decremented by one at every cycle of selected frequency f_{32} or f_{512} , and after 2048 counts, the most significant bit of watchdog timer become "0", and a watchdog timer interrupt request bit is set, and FFF_{16} is preset in the watchdog timer.

Normally, a program is written so that data is written in the watchdog timer before the most significant bit of the watchdog timer become "0". If this routine is not executed due to unexpected program execution, the most significant bit of the watchdog timer become eventually "0" and an interrupt is generated.

The processor can be reset by setting the bit 3 (software reset bit) of processor mode register described in Figure 10 in the interrupt section and generating a reset pulse.

The watchdog timer stops its function when the \overline{RESET} pin voltage is raised to double the V_{CC} voltage.

The watchdog timer can also be used to recover from when the clock is stopped by the STP instruction. Refer to the section on clock generation circuit for more details.

The watchdog timer hold the contents during a hold state and the frequency is stopped to input.

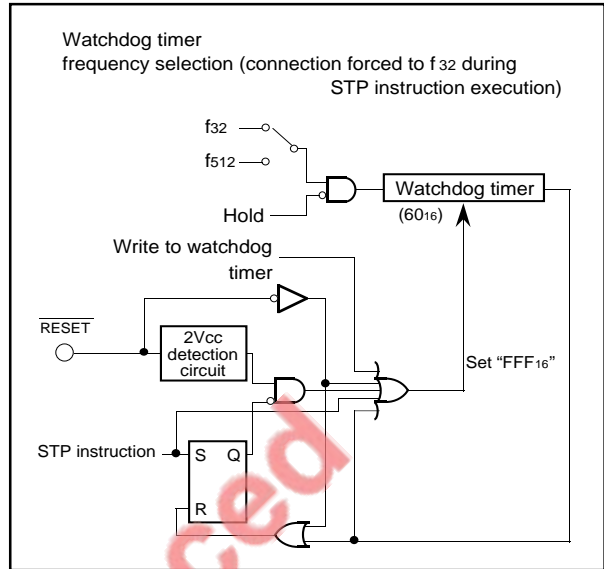

Fig. 46 Watchdog timer block diagram

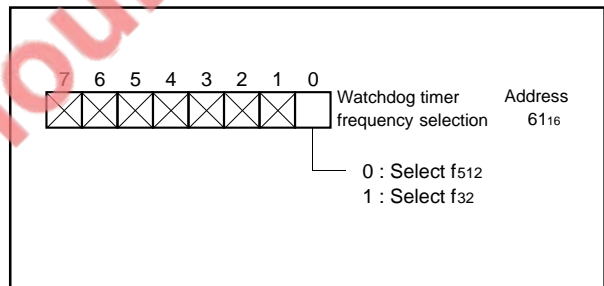

Fig. 47 Watchdog timer frequency selection flag

M37702M2AXXFP, M37702M2BXXFP M37702S1AFP, M37702S1BFP

SINGLE-CHIP 16-BIT CMOS MICROCOMPUTER

RESET CIRCUIT

Reset occurs when the RESET pin is returned to "H" level after holding it at "L" level when the power voltage is at $5\text{ V} \pm 10\%$. Program execution starts at the address formed by setting the address pins A23 – A16 to 0016, A15 – A8 to the contents of address FFFF16, and A7 – A0 to the contents of address FFFE16.

Figure 48 shows the status of the internal registers when a reset occurs.

Figure 49 shows an example of a reset circuit. The reset input voltage must be held 0.9 V or lower when the power voltage reaches 4.5 V.

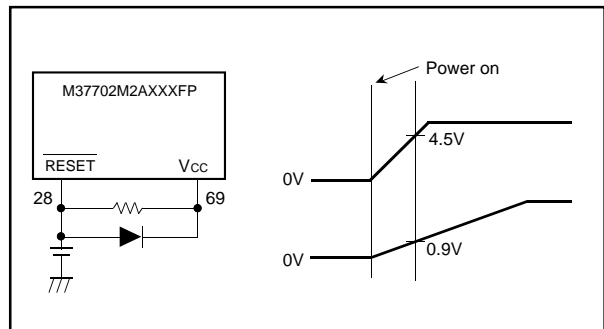

Fig. 49 Example of a reset circuit (perform careful evaluation at the system design level before using)

Register Name	Address	Value	Register Name	Address	Value
(1) Port P0 data direction register	(0416)...	0016	(29) Processor mode register	(5E16)...	0016
(2) Port P1 data direction register	(0516)...	0016	(30) Watchdog timer	(6016)...	FFF16
(3) Port P2 data direction register	(0816)...	0016	(31) Watchdog timer frequency selection flag	(6116)...	XXXXXXXXXX0
(4) Port P3 data direction register	(0916)...	XXXXXXXXXX0000	(32) A-D conversion interrupt control register	(7016)...	XXXXXXXXXX0000
(5) Port P4 data direction register	(0C16)...	0016	(33) UART 0 transmission interrupt control register	(7116)...	XXXXXXXXXX0000
(6) Port P5 data direction register	(0D16)...	0016	(34) UART 0 receive interrupt control register	(7216)...	XXXXXXXXXX0000
(7) Port P6 data direction register	(1016)...	0016	(35) UART 1 transmission interrupt control register	(7316)...	XXXXXXXXXX0000
(8) Port P7 data direction register	(1116)...	0016	(36) UART 1 receive interrupt control register	(7416)...	XXXXXXXXXX0000
(9) Port P8 data direction register	(1416)...	0016	(37) Timer A0 interrupt control register	(7516)...	XXXXXXXXXX0000
(10) A-D control register	(1E16)...	000000???	(38) Timer A1 interrupt control register	(7616)...	XXXXXXXXXX0000
(11) A-D sweep pin selection register	(1F16)...	XXXXXXXXXX11	(39) Timer A2 interrupt control register	(7716)...	XXXXXXXXXX0000
(12) UART 0 transmit/receive mode register	(3016)...	0016	(40) Timer A3 interrupt control register	(7816)...	XXXXXXXXXX0000
(13) UART 1 transmit/receive mode register	(3816)...	0016	(41) Timer A4 interrupt control register	(7916)...	XXXXXXXXXX0000
(14) UART 0 transmit/receive control register 0	(3416)...	XXXXXXXXXX1000	(42) Timer B0 interrupt control register	(7A16)...	XXXXXXXXXX0000
(15) UART 1 transmit/receive control register 0	(3C16)...	XXXXXXXXXX1000	(43) Timer B1 interrupt control register	(7B16)...	XXXXXXXXXX0000
(16) UART 0 transmit/receive control register 1	(3516)...	000000010	(44) Timer B2 interrupt control register	(7C16)...	XXXXXXXXXX0000
(17) UART 1 transmit/receive control register 1	(3D16)...	000000010	(45) INT0 interrupt control register	(7D16)...	XX00000000
(18) Count start flag	(4016)...	0016	(46) INT1 interrupt control register	(7E16)...	XX00000000
(19) One-shot start flag	(4216)...	XXXXXXXXXX0000	(47) INT2 interrupt control register	(7F16)...	XX00000000
(20) Up-down flag	(4416)...	0016	(48) Processor status register PS		000??00001??
(21) Timer A0 mode register	(5616)...	0016	(49) Program bank register PG		0016
(22) Timer A1 mode register	(5716)...	0016	(50) Program counter PC _H		Content of FFFF16
(23) Timer A2 mode register	(5816)...	0016	(51) Program counter PC _L		Content of FFFE16
(24) Timer A3 mode register	(5916)...	0016	(52) Direct page register DPR		000016
(25) Timer A4 mode register	(5A16)...	0016	(53) Data bank register DT		0016
(26) Timer B0 mode register	(5B16)...	001XXXX000			
(27) Timer B1 mode register	(5C16)...	001XXXX000			
(28) Timer B2 mode register	(5D16)...	001XXXX000			

Contents of other registers and RAM are not initialized and should be initialized by software.

Fig. 48 Microcomputer internal status during reset

**M37702M2AXXFP, M37702M2BXXFP
M37702S1AFP, M37702S1BFP**

SINGLE-CHIP 16-BIT CMOS MICROCOMPUTER

INPUT/OUTPUT PINS

Ports P8 to P0 all have a data direction register and each bit can be programmed for input or output. A pin becomes an output pin when the corresponding data direction register is set and an input pin when it is cleared.

When pin programmed for output, the data is written to the port latch and it is output to the output pin. When a pin is programmed for output, the contents of the port latch is read instead of the value of the pin. Therefore, a previously output value can be read correctly even when the output "L" voltage is raised due to reasons such as directly driving an LED.

A pin programmed for input is floating and the value input to the pin can be read. When a pin is programmed for input, the data is written only in the port latch and the pin stays floating.

If an input/output pin is not used as an output port, clear the bit of the corresponding data direction register so that the pin become input mode.

Figure 50 shows a block diagram of ports P8 to P0 in single-chip mode and the E pin output.

In memory expansion mode, microprocessor mode, and evaluation chip mode, ports P4 to P0 are also used as address, data, and control signal pins.

Refer to the section on processor modes for more details.

EOL announced

MITSUBISHI MICROCOMPUTERS
M37702M2AXXFP, M37702M2BXXFP
M37702S1AFP, M37702S1BFP

SINGLE-CHIP 16-BIT CMOS MICROCOMPUTER

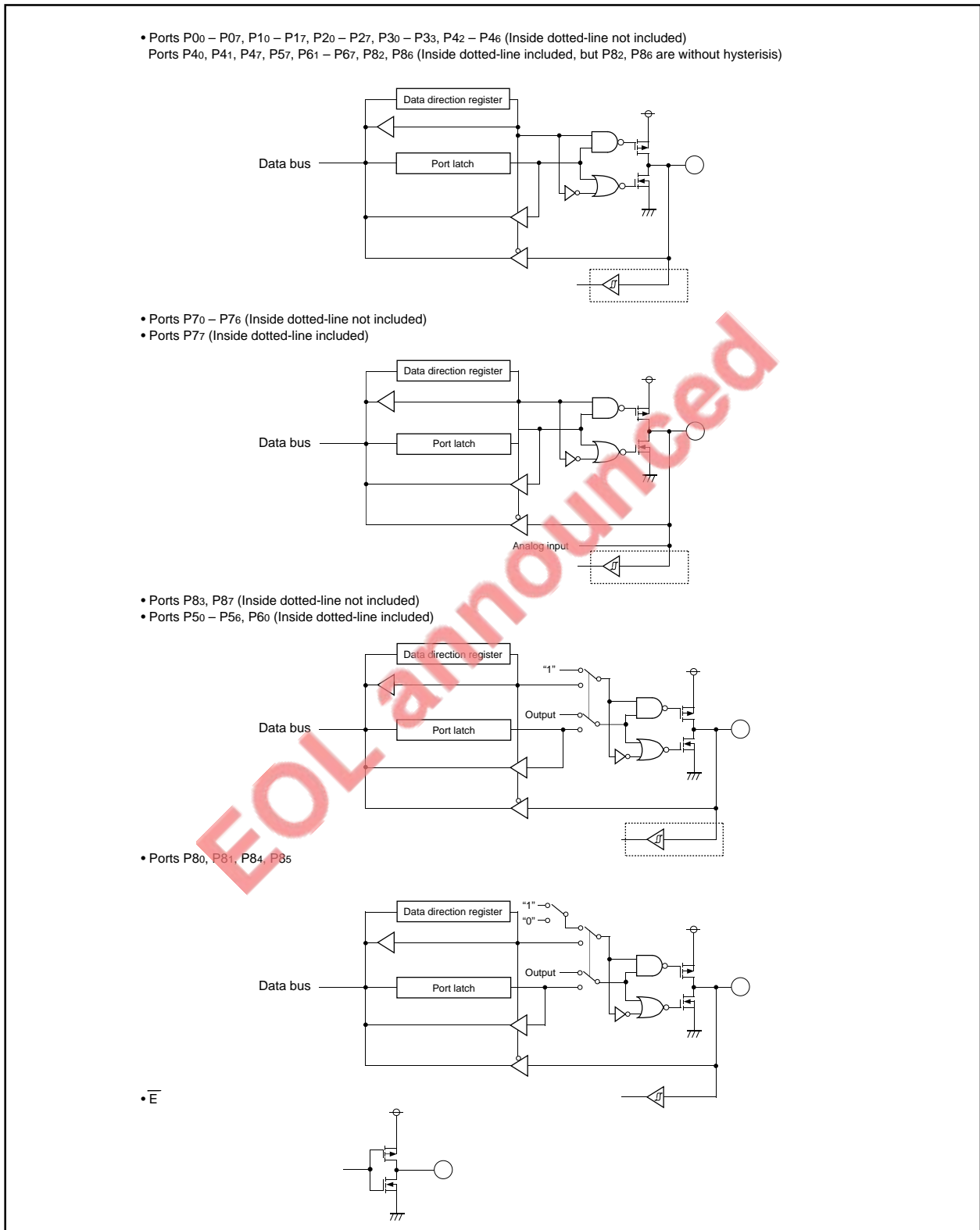

Fig. 50 Block diagram for ports P8 to P0 in single-chip mode and the \bar{E} pin output

**M37702M2AXXFP, M37702M2BXXFP
M37702S1AFP, M37702S1BFP**

SINGLE-CHIP 16-BIT CMOS MICROCOMPUTER

PROCESSOR MODE

The bits 0 and 1 of processor mode register as shown in Figure 51 are used to select any mode of single-chip mode, memory expansion mode, microprocessor mode, and evaluation chip mode. Ports P3 to P0 and a part of port P4 are used as address, data, and control signal I/O pins except in single-chip mode. Figure 52 shows the functions of ports P4 to P0 in each mode. The external memory area changes when the mode changes. Figure 53 shows the memory map for each mode. Refer to Figure 1 for the memory map of the single-chip mode. The external memory area can be accessed except in single-chip mode. The accessing of the external memory is affected by the BYTE pin and the bit 2 (wait bit) of processor mode register. These will be described next.

• BYTE pin

When accessing the external memory, the level of the BYTE pin is used to determine whether to use the data bus as 8-bit width or 16-bit width. The data bus width is 8 bits when the level of the BYTE pin is "H" and port P2 becomes the data I/O pin. The data bus width is 16 bits when the level of the BYTE pin is "L" and ports P1 and P2 become the data I/O pins. When accessing the internal memory, The data bus width is always 16 bits regardless of the BYTE pin level. An exclusive mode in the evaluation chip mode allows the BYTE pin level to be set to 2-VCC. In this case, the operation is slightly different from the above. This is described in the evaluation chip mode section.

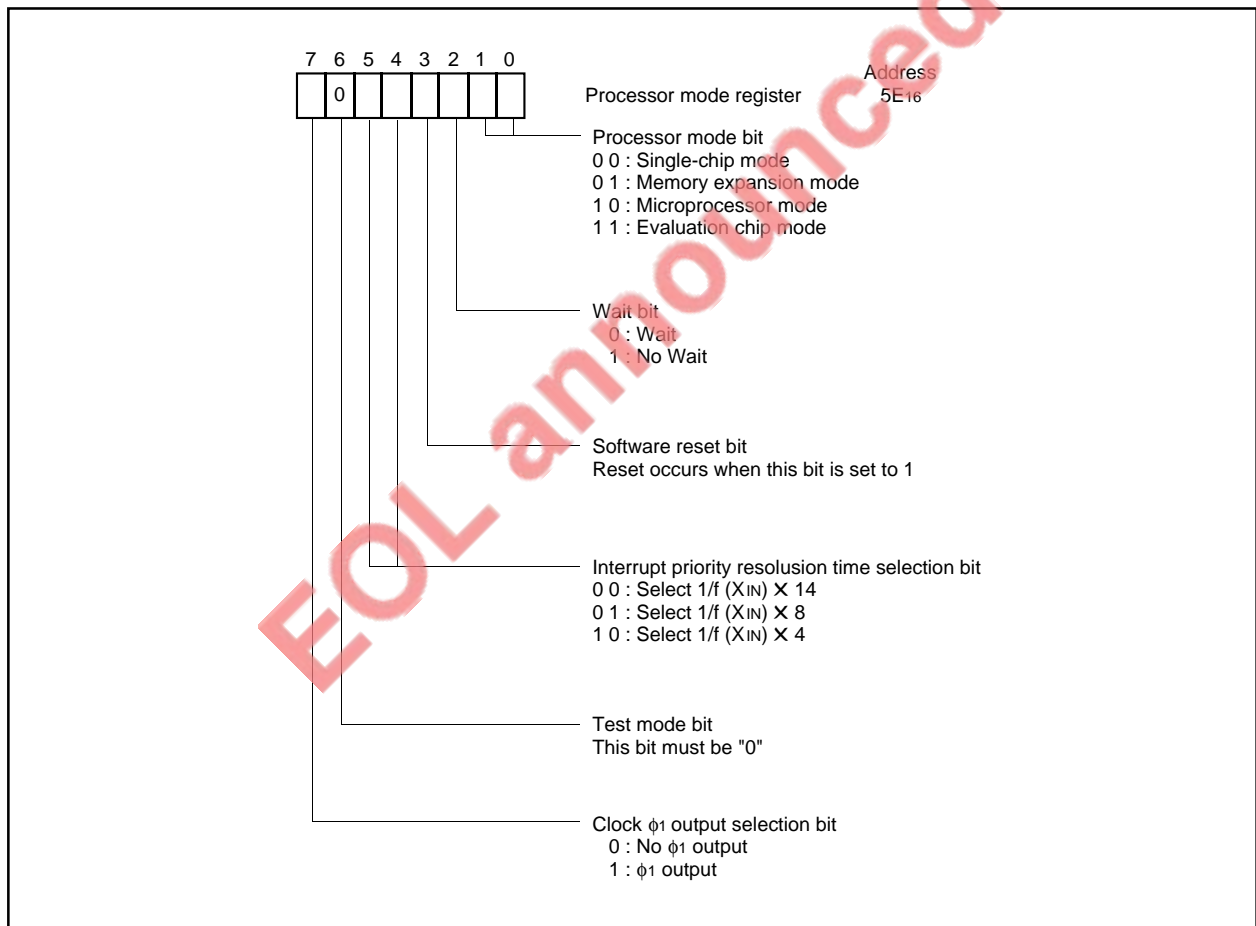

Fig. 51 Processor mode register bit configuration

MITSUBISHI MICROCOMPUTERS
M37702M2AXXFP, M37702M2BXXFP
M37702S1AFP, M37702S1BFP

SINGLE-CHIP 16-BIT CMOS MICROCOMPUTER

Port Mode		CM1	0	1	1
		CM0	0	1	0
Port Mode		0	1	0	1
		Single-chip Mode	Memory Expansion Mode	Microprocessor Mode	Evaluation Chip Mode
Port P0				Same as left	Same as left
Port P1	BYTE = "L"			Same as left	Same as left
	BYTE = "H" or 2 • Vcc (Evaluation chip mode only.)			Same as left	 Ports P4, P5 and their direction registers are treated as 16-bit wide bus. If BYTE = 2 • Vcc, the internal ROM area is also treated as 16-bit wide bus.
Port P2	BYTE = "L"			Same as left	Same as left
	BYTE = "H" or 2 • Vcc (Evaluation chip mode only.)			Same as left	 Same as for Port P1
Port P3				Same as left	Same as left
Port P4				—	
		* When processor mode register bit 7 = "0" Same as above except P42 * When processor mode register bit 7 = "1"	* When processor mode register bit 7 = "0" Same as above except P42 * When processor mode register bit 7 = "1"	Same as left in spite of processor mode register bit 7	

Fig. 52 Processor mode and ports P4 to P0 functions

MITSUBISHI MICROCOMPUTERS

M37702M2AXXFP, M37702M2BXXFP M37702S1AFP, M37702S1BFP

SINGLE-CHIP 16-BIT CMOS MICROCOMPUTER

• **Wait bit**

As shown in Figure 54, when the external memory area is accessed with the processor mode register bit 2 (wait bit) cleared to "0", the "L" width of \bar{E} signal becomes twice compared with no wait (the wait bit is "1"). The wait bit is cleared to "0" at reset. The accessing of internal memory area is performed in no wait mode regardless of the wait bit. The processor modes are described below.

(1) Single-chip mode [00]

Single-chip mode is entered by connecting the CNVss pin to Vss and starting from reset. Ports P4 to P0 all function as normal I/O ports. Port P4 can be the ϕ_1 output pin divided the clock to XIN pin by 2 by setting bit 7 of processor mode register to "1".

(2) Memory expansion mode [01]

Memory expansion mode is entered by setting the processor mode bits to "01" after connecting the CNVss pin to Vss and starting from reset.

Port P0 becomes an address output pin and loses its I/O port function.

Port P1 has two functions depending on the level of the BYTE pin. When the BYTE pin level is "L", port P1 functions as an address output pin while \bar{E} is "H" and as an odd address data I/O pin while \bar{E} is "L". However, if an internal memory is read, external data is ignored while \bar{E} is "L". In this case the I/O port function is lost.

When the BYTE pin level "H", port P1 functions as an address output pin and loses its I/O port function.

Port P2 has two functions depending on the level of the BYTE pin. When the BYTE pin level is "L", port P2 functions as an address output pin while \bar{E} is "H" and as an even address data I/O pin while \bar{E} is "L". However, if an internal memory is read, external data is ignored while \bar{E} is "L".

When the BYTE pin level is "H", port P2 functions as an address output pin while \bar{E} is "H" and as an even and odd address data I/O pin while \bar{E} is "L". However, if an internal memory is read, external data is ignored while \bar{E} is "L". In this case the I/O port function is lost.

Ports P30, P31, P32, and P33 become R/\bar{W} , \bar{BHE} , ALE, and \overline{HLDA} output pin respectively and lose their I/O port functions.

R/\bar{W} is a read/write signal which indicates a read when it is "H" and a write when it is "L".

\bar{BHE} is a byte high enable signal which indicates that an odd address is accessed when it is "L".

Therefore, two bytes at even and odd addresses are accessed simultaneously if address A0 is "L" and \bar{BHE} is "L".

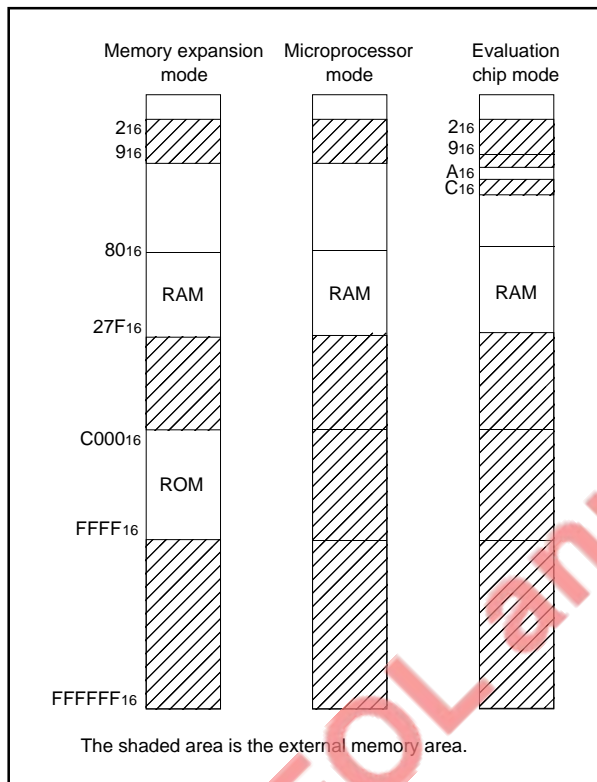

Fig. 53 External memory area for each processor mode

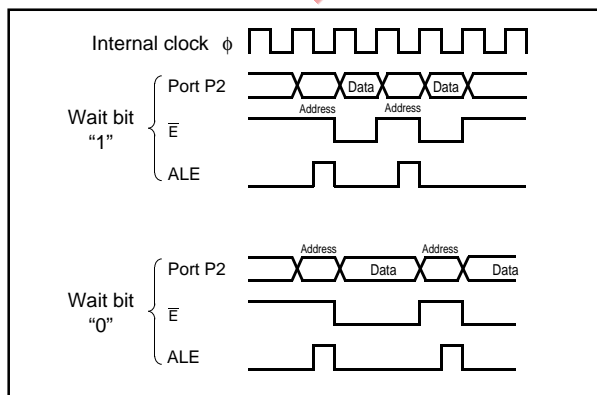

Fig. 54 Relationship between wait bit and access time

**M37702M2AXXFP, M37702M2BXXFP
M37702S1AFP, M37702S1BFP**

SINGLE-CHIP 16-BIT CMOS MICROCOMPUTER

ALE is an address latch enable signal used to latch the address signal from a multiplexed signal of address and data. The latch is transparent while ALE is "H" to let the address signal pass through and held while ALE is "L".

$\overline{\text{HLDA}}$ is a hold acknowledge signal and is used to notify externally when the microcomputer receives $\overline{\text{HOLD}}$ input and enters into hold state.

Ports P40 and P41 become $\overline{\text{HOLD}}$ and $\overline{\text{RDY}}$ input pin respectively and lose their output pin function, but the input pin function remains.

$\overline{\text{HOLD}}$ is a hold request signal. It is an input signal used to put the microcomputer in hold state. $\overline{\text{HOLD}}$ input is accepted when the internal clock ϕ falls from "H" level to "L" level while the bus is not used. Ports P0, P1, P2, P30, and P31 are floating while the microcomputer stays in hold state. These ports are floating after one cycle of the internal clock ϕ later than $\overline{\text{HLDA}}$ signal changes to "L" level. At the removing of hold state, these ports are removed from floating state after one cycle of ϕ later than $\overline{\text{HLDA}}$ signal changes to "H" level.

$\overline{\text{RDY}}$ is a ready signal. If this signal goes "L", the internal clock ϕ stops at "L". When ϕ_1 output from port P42 is selected by setting bit 7 of processor mode register to "1", ϕ_1 output keeps on. $\overline{\text{RDY}}$ is used when slow external memory is attached.

(3) Microprocessor mode [10]

Microprocessor mode is entered by connecting the CNVSS pin to VCC and starting from reset. It can also be entered by programming the processor mode bits to "10" after connecting the CNVSS pin to Vss and starting from reset. This mode is similar to memory expansion mode except that internal ROM is disabled and an external memory is required, and ϕ_1 from port P42 is always output in spite of bit 7 of processor mode register.

(4) Evaluation chip mode [11]

Evaluation chip mode is entered by applying voltage twice the Vcc voltage to the CNVSS pin. This mode is normally used for evaluation tools.

The functions of ports P0 and P3 are the same as in memory expansion mode.

Port P1 functions as an address output pin while $\overline{\text{E}}$ is "H" and as data I/O pin of odd addresses while $\overline{\text{E}}$ is "L" regardless of the BYTE pin level. However, if an internal memory is read, external data is ignored while $\overline{\text{E}}$ is "L".

Port P2 function as an address output pin while $\overline{\text{E}}$ is "H" and as data I/O pin of even addresses while $\overline{\text{E}}$ is "L" when the BYTE pin level is "L". However, if an internal memory is read, external data is ignored while $\overline{\text{E}}$ is "L".

When the BYTE pin level is "H" or 2-VCC, port P2 functions as an address output pin while $\overline{\text{E}}$ is "H" and as data I/O pin of even and odd addresses while $\overline{\text{E}}$ is "L". However, if an internal memory is read, external data is ignored while $\overline{\text{E}}$ is "L".

Port P4 and its data direction register which are located at address 0A16 and 0C16 are treated differently in evaluation chip mode. When these addresses are accessed, the data bus width is treated as 16 bits regardless of the BYTE pin level, and the access cycle is treated as internal memory regardless of the wait bit.

When a voltage twice the Vcc voltage is applied to the BYTE pin, the addresses corresponding to the internal ROM area are also treated as 16-bit data bus.

The functions of ports P40 and P41 are the same as in memory expansion mode.

Ports P42 to P46 become ϕ_1 , MX, QCL, VDA, and VPA output pins respectively. Port P47 becomes the $\overline{\text{DBC}}$ input pin.

ϕ_1 from port P42 divided the clock to XIN pin by 2 is always output in spite of bit 7 of processor mode register.

The MX signal normally contains the contents of flag m, but the contents of flag x is output if the CPU is using flag x.

QCL is the queue buffer clear signal. It becomes "H" when the instruction queue buffer is cleared, for example, when a jump instruction is executed.

VDA is the valid data address signal. It becomes "H" while the CPU is reading data from data buffer or writing data to data buffer. It also becomes "H" when the first byte of the instruction (operation code) is read from the instruction queue buffer.

VPA is the valid program address signal. It becomes "H" while the CPU is reading an instruction code from the instruction queue buffer.

$\overline{\text{DBC}}$ is the debug control signal and is used for debugging. Table 5 shows the relationship between the CNVSS pin input levels and processor modes.

Table 5. Relationship between the CNVSS pin input levels and processor modes

CNVSS	Mode	Description
Vss	<ul style="list-style-type: none"> • Single-chip • Memory expansion • Microprocessor • Evaluation chip 	Single-chip mode upon starting after reset. Other modes can be selected by changing the processor mode bit by software.
Vcc	<ul style="list-style-type: none"> • Microprocessor • Evaluation chip 	Microprocessor mode upon starting after reset. Evaluation chip mode can be selected by changing the processor mode bit by software.
2-Vcc	<ul style="list-style-type: none"> • Evaluation chip 	• Evaluation chip mode only.

**M37702M2AXXFP, M37702M2BXXFP
M37702S1AFP, M37702S1BFP**

SINGLE-CHIP 16-BIT CMOS MICROCOMPUTER

CLOCK GENERATING CIRCUIT

Figure 55 shows a block diagram of the clock generator. When an STP instruction is executed, the internal clock ϕ stops oscillating at "L" level. At the same time, FFF16 is written to watchdog timer and the watchdog timer input connection is forced to f32. This connection is broken and connected to the input determined by the watchdog timer frequency selection flag when the most significant bit of the watchdog timer is cleared or reset. Oscillation resumes when an interrupt is received, but the internal clock ϕ remains at "L" level until the most significant bit of the watchdog timer is cleared. This is to avoid the unstable interval at the start of oscillation when using a ceramic resonator. When a WIT instruction is executed, the internal clock ϕ stops at "L" level, but the oscillator does not stop. The clock is restarted when an interrupt is received. Instructions can be executed immediately because the oscillator is not stopped. The stop or wait state is released when an interrupt is received or when reset is issued. Therefore, interrupts must be enabled before executing a STP or WIT instruction. Figure 56 shows a circuit example using a ceramic (or quartz crystal) resonator. Use the manufacture's recommended values for constants such as capacitance which differ for each resonator. Figure 57 shows an example of using an external clock signal.

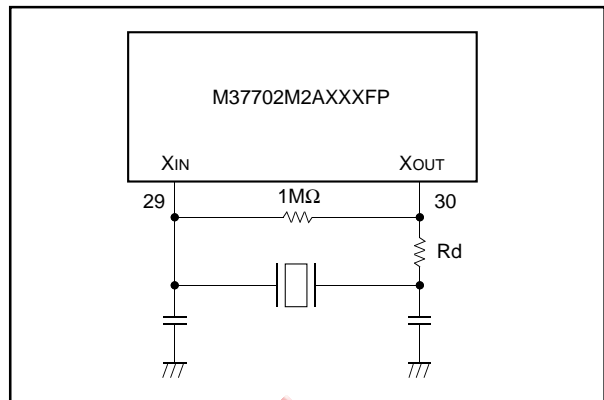

Fig. 56 Circuit using a ceramic resonator

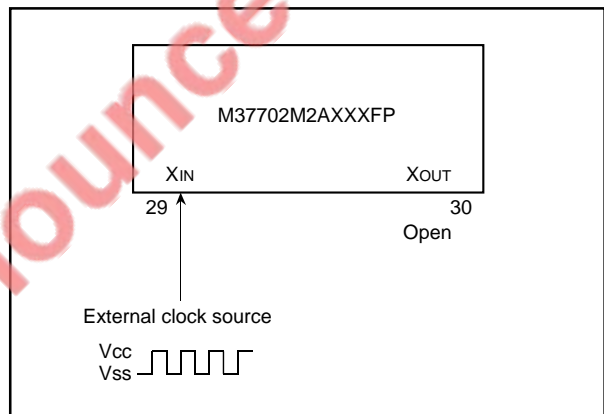

Fig. 57 External clock input circuit

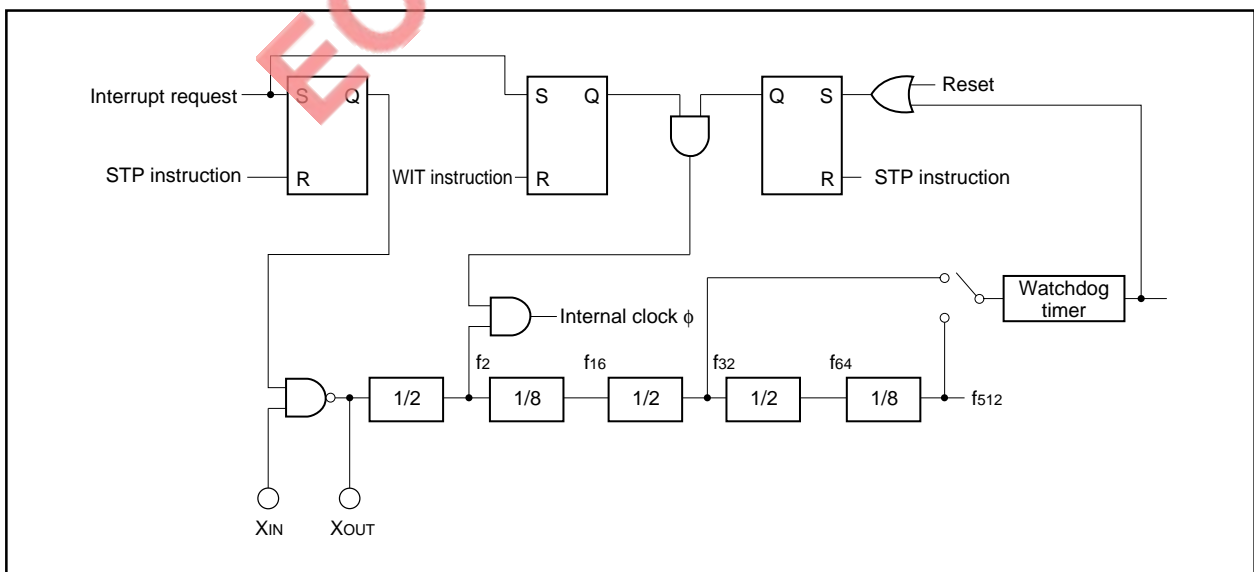

Fig. 55 Block diagram of a clock generator

**M37702M2AXXFP, M37702M2BXXFP
M37702S1AFP, M37702S1BFP**

SINGLE-CHIP 16-BIT CMOS MICROCOMPUTER

ADDRESSING MODES

The M37702M2AXXFP has 28 powerful addressing modes. Refer to the 7700 Family addressing mode description for the details of each addressing mode.

MACHINE INSTRUCTION LIST

The M37702M2AXXFP has 103 machine instructions. Refer to the 7700 Family machine instruction list for details.

DATA REQUIRED FOR MASK ORDERING

Please send the following data for mask orders.

- (1) Mask ROM order confirmation form
- (2) 80P6N mark specification form
- (3) ROM data (EPROM 3 sets)

EOL announced

**M37702M2AXXFP, M37702M2BXXFP
M37702S1AFP, M37702S1BFP**

SINGLE-CHIP 16-BIT CMOS MICROCOMPUTER

M37702M2AXXFP

ELECTRICAL CHARACTERISTICS ($V_{CC} = 5\text{ V}$, $V_{SS} = 0\text{ V}$, $T_a = 25\text{ }^\circ\text{C}$, $f(XIN) = 16\text{ MHz}$, unless otherwise noted)

Symbol	Parameter	Test conditions	Limits			Unit
			Min.	Typ.	Max.	
VOH	High-level output voltage P00–P07, P10–P17, P20–P27, P30, P31, P33, P40–P47, P50–P57, P60–P67, P70–P77, P80–P87	IOH = –10 mA	3			V
VOH	High-level output voltage P00–P07, P10–P17, P20–P27, P30, P31, P33	IOH = –400 μA	4.7			V
VOH	High-level output voltage P32	IOH = –10 mA	3.1			V
		IOH = –400 μA	4.8			
VOH	High-level output voltage \bar{E}	IOH = –10 mA	3.4			V
		IOH = –400 μA	4.8			
VOL	Low-level output voltage P00–P07, P10–P17, P20–P27, P30, P31, P33, P40–P47, P50–P57, P60–P67, P70–P77, P80–P87	IOL = 10 mA			2	V
VOL	Low-level output voltage P00–P07, P10–P17, P20–P27, P30, P31, P33	IOL = 2 mA			0.45	V
VOL	Low-level output voltage P32	IOL = 10 mA			1.9	V
		IOL = 2 mA			0.43	
VOL	Low-level output voltage \bar{E}	IOL = 10 mA			1.6	V
		IOL = 2 mA			0.4	
VT+ – VT–	Hysteresis HOLD, RDY, TA0IN–TA4IN, TB0IN–TB2IN, INT0–INT2, ADTRG, CTS0, CTS1, CLK0, CLK1		0.4		1	V
VT+ – VT–	Hysteresis RESET		0.2		0.5	V
VT+ – VT–	Hysteresis XIN		0.1		0.3	V
IiH	High-level input current P00–P07, P10–P17, P20–P27, P30–P33, P40–P47, P50–P57, P60–P67, P70–P77, P80–P87, XIN, RESET, CNVss, BYTE	Vi = 5 V			5	μA
IiL	Low-level input current P00–P07, P10–P17, P20–P27, P30–P33, P40–P47, P50–P57, P60–P67, P70–P77, P80–P87, XIN, RESET, CNVss, BYTE	Vi = 0 V			–5	μA
VRAM	RAM hold voltage	When clock is stopped.	2			V
ICC	Power supply current	In single-chip mode output only pin is open and other pins are Vss during reset.	f(XIN) = 16 MHz, square waveform	12	24	mA
			Ta = 25 $^\circ\text{C}$ when clock is stopped.		1	μA
			Ta = 85 $^\circ\text{C}$ when clock is stopped.		20	μA

A-D CONVERTER CHARACTERISTICS ($V_{CC} = 5\text{ V}$, $V_{SS} = 0\text{ V}$, $T_a = 25\text{ }^\circ\text{C}$, $f(XIN) = 16\text{ MHz}$, unless otherwise noted)

Symbol	Parameter	Test conditions	Limits			Unit
			Min.	Typ.	Max.	
—	Resolution	VREF = VCC			8	Bits
—	Absolute accuracy	VREF = VCC			± 3	LSB
RLADDER	Ladder resistance	VREF = VCC	2		10	k Ω
tCONV	Conversion time		14.25			μs
VREF	Reference voltage		2		VCC	V
VIA	Analog input voltage		0		VREF	V

**M37702M2AXXFP, M37702M2BXXFP
M37702S1AFP, M37702S1BFP**

SINGLE-CHIP 16-BIT CMOS MICROCOMPUTER

ABSOLUTE MAXIMUM RATINGS

Symbol	Parameter	Conditions	Ratings	Unit
V _{CC}	Supply voltage		-0.3 to 7	V
AV _{CC}	Analog supply voltage		-0.3 to 7	V
V _I	Input voltage $\overline{\text{RESET}}$, CNV _{SS} , BYTE		-0.3 to 12	V
V _I	Input voltage P00-P07, P10-P17, P20-P27, P30-P33, P40-P47, P50-P57, P60-P67, P70-P77, P80-P87, V _{REF} , X _{IN}		-0.3 to V _{CC} +0.3	V
V _O	Output voltage P00-P07, P10-P17, P20-P27, P30-P33, P40-P47, P50-P57, P60-P67, P70-P77, P80-P87, X _{OUT} , E		-0.3 to V _{CC} +0.3	V
P _d	Power dissipation	T _a = 25 °C	300	mW
T _{opr}	Operating temperature		-20 to 85	°C
T _{stg}	Storage temperature		-40 to 150	°C

RECOMMENDED OPERATING CONDITIONS (V_{CC} = 5 V ± 10%, T_a = -20 to 85 °C, unless otherwise noted)

Symbol	Parameter	Limits			Unit
		Min.	Typ.	Max.	
V _{CC}	Supply voltage	4.5	5.0	5.5	V
AV _{CC}	Analog supply voltage		V _{CC}		V
V _{SS}	Supply voltage		0		V
AV _{SS}	Analog supply voltage		0		V
V _{IH}	High-level input voltage P00-P07, P30-P33, P40-P47, P50-P57, P60-P67, P70-P77, P80-P87, X _{IN} , $\overline{\text{RESET}}$, CNV _{SS} , BYTE	0.8V _{CC}		V _{CC}	V
V _{IH}	High-level input voltage P10-P17, P20-P27 (in single-chip mode)	0.8V _{CC}		V _{CC}	V
V _{IH}	High-level input voltage P10-P17, P20-P27 (in memory expansion mode and micro-processor mode)	0.5V _{CC}		V _{CC}	V
V _{IL}	Low-level input voltage P00-P07, P30-P33, P40-P47, P50-P57, P60-P67, P70-P77, P80-P87, X _{IN} , $\overline{\text{RESET}}$, CNV _{SS} , BYTE	0		0.2V _{CC}	V
V _{IL}	Low-level input voltage P10-P17, P20-P27 (in single-chip mode)	0		0.2V _{CC}	V
V _{IL}	Low-level input voltage P10-P17, P20-P27 (in memory expansion mode and micro-processor mode)	0		0.16V _{CC}	V
I _{OH(peak)}	High-level peak output current P00-P07, P10-P17, P20-P27, P30-P33, P40-P47, P50-P57, P60-P67, P70-P77, P80-P87			-10	mA
I _{OH(avg)}	High-level average output current P00-P07, P10-P17, P20-P27, P30-P33, P40-P47, P50-P57, P60-P67, P70-P77, P80-P87			-5	mA
I _{OL(peak)}	Low-level peak output current P00-P07, P10-P17, P20-P27, P30-P33, P40-P47, P50-P57, P60-P67, P70-P77, P80-P87			10	mA
I _{OL(avg)}	Low-level average output current P00-P07, P10-P17, P20-P27, P30-P33, P40-P47, P50-P57, P60-P67, P70-P77, P80-P87			5	mA
f(X _{IN})	External clock frequency input	M37702M2AXXFP, M37702S1AFP		16	MHz
		M37702M2BXXFP, M37702S1BFP		25	

Note 1. Average output current is the average value of a 100 ms interval.

2. The sum of I_{OL(peak)} for ports P0, P1, P2, P3, and P8 must be 80 mA or less, the sum of I_{OH(peak)} for ports P0, P1, P2, P3, and P8 must be 80 mA or less, the sum of I_{OL(peak)} for ports P4, P5, P6, and P7 must be 80 mA or less, and the sum of I_{OH(peak)} for ports P4, P5, P6, and P7 must be 80 mA or less.

MITSUBISHI MICROCOMPUTERS

M37702M2AXXFP, M37702M2BXXFP
M37702S1AFP, M37702S1BFP

SINGLE-CHIP 16-BIT CMOS MICROCOMPUTER

TIMING REQUIREMENTS ($V_{CC} = 5\text{ V} \pm 10\%$, $V_{SS} = 0\text{ V}$, $T_a = 25\text{ }^\circ\text{C}$, unless otherwise noted)

External clock input

Symbol	Parameter	Limits				Unit
		16 MHz		25 MHz		
		Min.	Max.	Min.	Max.	
t_c	External clock input cycle time	62		40		ns
$t_{w(H)}$	External clock input high-level pulse width	25		15		ns
$t_{w(L)}$	External clock input low-level pulse width	25		15		ns
t_r	External clock rise time		10		8	ns
t_f	External clock fall time		10		8	ns

Single-chip mode

Symbol	Parameter	Limits				Unit
		16 MHz		25 MHz		
		Min.	Max.	Min.	Max.	
$t_{su}(P0D-E)$	Port P0 input setup time	100		60		ns
$t_{su}(P1D-E)$	Port P1 input setup time	100		60		ns
$t_{su}(P2D-E)$	Port P2 input setup time	100		60		ns
$t_{su}(P3D-E)$	Port P3 input setup time	100		60		ns
$t_{su}(P4D-E)$	Port P4 input setup time	100		60		ns
$t_{su}(P5D-E)$	Port P5 input setup time	100		60		ns
$t_{su}(P6D-E)$	Port P6 input setup time	100		60		ns
$t_{su}(P7D-E)$	Port P7 input setup time	100		60		ns
$t_{su}(P8D-E)$	Port P8 input setup time	100		60		ns
$t_{h(E-P0D)}$	Port P0 input hold time	0		0		ns
$t_{h(E-P1D)}$	Port P1 input hold time	0		0		ns
$t_{h(E-P2D)}$	Port P2 input hold time	0		0		ns
$t_{h(E-P3D)}$	Port P3 input hold time	0		0		ns
$t_{h(E-P4D)}$	Port P4 input hold time	0		0		ns
$t_{h(E-P5D)}$	Port P5 input hold time	0		0		ns
$t_{h(E-P6D)}$	Port P6 input hold time	0		0		ns
$t_{h(E-P7D)}$	Port P7 input hold time	0		0		ns
$t_{h(E-P8D)}$	Port P8 input hold time	0		0		ns

Memory expansion mode and microprocessor mode

Symbol	Parameter	Limits				Unit
		16 MHz		25 MHz		
		Min.	Max.	Min.	Max.	
$t_{su}(P1D-E)$	Port P1 input setup time	45		30		ns
$t_{su}(P2D-E)$	Port P2 input setup time	45		30		ns
$t_{su}(RDY-\phi_1)$	RDY input setup time	60		55		ns
$t_{su}(HOLD-\phi_1)$	HOLD input setup time	60		55		ns
$t_{h(E-P1D)}$	Port P1 input hold time	0		0		ns
$t_{h(E-P2D)}$	Port P2 input hold time	0		0		ns
$t_{h}(\phi_1-RDY)$	RDY input hold time	0		0		ns
$t_{h}(\phi_1-HOLD)$	HOLD input hold time	0		0		ns

**M37702M2AXXFP, M37702M2BXXFP
M37702S1AFP, M37702S1BFP**

SINGLE-CHIP 16-BIT CMOS MICROCOMPUTER

M37702M2BXXFP

ELECTRICAL CHARACTERISTICS ($V_{CC} = 5\text{ V}$, $V_{SS} = 0\text{ V}$, $T_a = 25\text{ }^\circ\text{C}$, $f(XIN) = 25\text{ MHz}$, unless otherwise noted)

Symbol	Parameter	Test conditions	Limits			Unit
			Min.	Typ.	Max.	
VOH	High-level output voltage P00–P07, P10–P17, P20–P27, P30, P31, P33, P40–P47, P50–P57, P60–P67, P70–P77, P80–P87	IOH = –10 mA	3			V
VOH	High-level output voltage P00–P07, P10–P17, P20–P27, P30, P31, P33	IOH = –400 μA	4.7			V
VOH	High-level output voltage P32	IOH = –10 mA	3.1			V
		IOH = –400 μA	4.8			
VOH	High-level output voltage \bar{E}	IOH = –10 mA	3.4			V
		IOH = –400 μA	4.8			
VOL	Low-level output voltage P00–P07, P10–P17, P20–P27, P30, P31, P33, P40–P47, P50–P57, P60–P67, P70–P77, P80–P87	IOL = 10 mA			2	V
VOL	Low-level output voltage P00–P07, P10–P17, P20–P27, P30, P31, P33	IOL = 2 mA			0.45	V
VOL	Low-level output voltage P32	IOL = 10 mA			1.9	V
		IOL = 2 mA			0.43	
VOL	Low-level output voltage \bar{E}	IOL = 10 mA			1.6	V
		IOL = 2 mA			0.4	
VT+ – VT–	Hysteresis HOLD, RDY, TA0IN–TA4IN, TB0IN–TB2IN, INT0–INT2, ADTRG, CTS0, CTS1, CLK0, CLK1		0.4		1	V
VT+ – VT–	Hysteresis RESET		0.2		0.5	V
VT+ – VT–	Hysteresis XIN		0.1		0.3	V
IiH	High-level input current P00–P07, P10–P17, P20–P27, P30–P33, P40–P47, P50–P57, P60–P67, P70–P77, P80–P87, XIN, RESET, CNVss, BYTE	Vi = 5 V			5	μA
IiL	Low-level input current P00–P07, P10–P17, P20–P27, P30–P33, P40–P47, P50–P57, P60–P67, P70–P77, P80–P87, XIN, RESET, CNVss, BYTE	Vi = 0 V			–5	μA
VRAM	RAM hold voltage	When clock is stopped.	2			V
ICC	Power supply current	In single-chip mode output only pin is open and other pins are Vss during reset.	f(XIN) = 25 MHz, square waveform	19	38	mA
			Ta = 25 $^\circ\text{C}$ when clock is stopped.		1	μA
			Ta = 85 $^\circ\text{C}$ when clock is stopped.		20	μA

A-D CONVERTER CHARACTERISTICS ($V_{CC} = 5\text{ V}$, $V_{SS} = 0\text{ V}$, $T_a = 25\text{ }^\circ\text{C}$, $f(XIN) = 25\text{ MHz}$, unless otherwise noted)

Symbol	Parameter	Test conditions	Limits			Unit
			Min.	Typ.	Max.	
—	Resolution	VREF = VCC			8	Bits
—	Absolute accuracy	VREF = VCC			± 3	LSB
RLADDER	Ladder resistance	VREF = VCC	2		10	k Ω
tCONV	Conversion time		9.12			μs
VREF	Reference voltage		2		VCC	V
VIA	Analog input voltage		0		VREF	V

mitsubishi microcomputers
M37702M2AXXFP, M37702M2BXXFP
M37702S1AFP, M37702S1BFP

SINGLE-CHIP 16-BIT CMOS MICROCOMPUTER

Timer A input (Count input in event counter mode)

Symbol	Parameter	Limits				Unit
		16 MHz		25 MHz		
		Min.	Max.	Min.	Max.	
t _c (TA)	TAiIN input cycle time	125		80		ns
t _w (TAH)	TAiIN input high-level pulse width	62		40		ns
t _w (TAL)	TAiIN input low-level pulse width	62		40		ns

Timer A input (Gating input in timer mode)

Symbol	Parameter	Limits				Unit
		16 MHz		25 MHz		
		Min.	Max.	Min.	Max.	
t _c (TA)	TAiIN input cycle time	500		320		ns
t _w (TAH)	TAiIN input high-level pulse width	250		160		ns
t _w (TAL)	TAiIN input low-level pulse width	250		160		ns

Timer A input (External trigger input in one-shot pulse mode)

Symbol	Parameter	Limits				Unit
		16 MHz		25 MHz		
		Min.	Max.	Min.	Max.	
t _c (TA)	TAiIN input cycle time	250		160		ns
t _w (TAH)	TAiIN input high-level pulse width	125		80		ns
t _w (TAL)	TAiIN input low-level pulse width	125		80		ns

Timer A input (External trigger input in pulse width modulation mode)

Symbol	Parameter	Limits				Unit
		16 MHz		25 MHz		
		Min.	Max.	Min.	Max.	
t _w (TAH)	TAiIN input high-level pulse width	125		80		ns
t _w (TAL)	TAiIN input low-level pulse width	125		80		ns

Timer A input (Up-down input in event counter mode)

Symbol	Parameter	Limits				Unit
		16 MHz		25 MHz		
		Min.	Max.	Min.	Max.	
t _c (UP)	TAiOUT input cycle time	2500		2000		ns
t _w (UPH)	TAiOUT input high-level pulse width	1250		1000		ns
t _w (UPL)	TAiOUT input low-level pulse width	1250		1000		ns
t _{su} (UP-TiN)	TAiOUT input setup time	500		400		ns
t _h (TiN-UP)	TAiOUT input hold time	500		400		ns

**M37702M2AXXFP, M37702M2BXXFP
M37702S1AFP, M37702S1BFP**

SINGLE-CHIP 16-BIT CMOS MICROCOMPUTER

Timer B input (Count input in event counter mode)

Symbol	Parameter	Limits				Unit
		16 MHz		25 MHz		
		Min.	Max.	Min.	Max.	
t _c (TB)	TBiN input cycle time (one edge count)	125		80		ns
t _w (TBH)	TBiN input high-level pulse width (one edge count)	62		40		ns
t _w (TBL)	TBiN input low-level pulse width (one edge count)	62		40		ns
t _c (TB)	TBiN input cycle time (both edges count)	250		160		ns
t _w (TBH)	TBiN input high-level pulse width (both edges count)	125		80		ns
t _w (TBL)	TBiN input low-level pulse width (both edges count)	125		80		ns

Timer B input (Pulse period measurement mode)

Symbol	Parameter	Limits				Unit
		16 MHz		25 MHz		
		Min.	Max.	Min.	Max.	
t _c (TB)	TBiN input cycle time	500		320		ns
t _w (TBH)	TBiN input high-level pulse width	250		160		ns
t _w (TBL)	TBiN input low-level pulse width	250		160		ns

Timer B input (Pulse width measurement mode)

Symbol	Parameter	Limits				Unit
		16 MHz		25 MHz		
		Min.	Max.	Min.	Max.	
t _c (TB)	TBiN input cycle time	500		320		ns
t _w (TBH)	TBiN input high-level pulse width	250		160		ns
t _w (TBL)	TBiN input low-level pulse width	250		160		ns

A-D trigger input

Symbol	Parameter	Limits				Unit
		16 MHz		25 MHz		
		Min.	Max.	Min.	Max.	
t _c (AD)	ADTRG input cycle time (minimum allowable trigger)	1000		1000		ns
t _w (ADL)	ADTRG input low-level pulse width	125		125		ns

Serial I/O

Symbol	Parameter	Limits				Unit
		16 MHz		25 MHz		
		Min.	Max.	Min.	Max.	
t _c (CK)	CLK _i input cycle time	250		200		ns
t _w (CKH)	CLK _i input high-level pulse width	125		100		ns
t _w (CKL)	CLK _i input low-level pulse width	125		100		ns
t _d (C-Q)	TxD _i output delay time		90		80	ns
t _h (C-Q)	TxD _i hold time	0		0		ns
t _{su} (D-C)	RxD _i input setup time	30		20		ns
t _h (C-D)	RxD _i input hold time	90		90		ns

External interrupt INT_i input

Symbol	Parameter	Limits				Unit
		16 MHz		25 MHz		
		Min.	Max.	Min.	Max.	
t _w (INH)	INT _i input high-level pulse width	250		250		ns
t _w (INL)	INT _i input low-level pulse width	250		250		ns

mitsubishi microcomputers
M37702M2AXXFP, M37702M2BXXFP
M37702S1AFP, M37702S1BFP

SINGLE-CHIP 16-BIT CMOS MICROCOMPUTER

SWITCHING CHARACTERISTICS ($V_{CC} = 5\text{ V} \pm 10\%$, $V_{SS} = 0\text{ V}$, $T_a = 25\text{ }^\circ\text{C}$, unless otherwise noted)

Single-chip mode

Symbol	Parameter	Test conditions	Limits				Unit
			16 MHz		25 MHz		
			Min.	Max.	Min.	Max.	
td(E-P0Q)	Port P0 data output delay time	Fig. 58		100		80	ns
td(E-P1Q)	Port P1 data output delay time			100		80	ns
td(E-P2Q)	Port P2 data output delay time			100		80	ns
td(E-P3Q)	Port P3 data output delay time			100		80	ns
td(E-P4Q)	Port P4 data output delay time			100		80	ns
td(E-P5Q)	Port P5 data output delay time			100		80	ns
td(E-P6Q)	Port P6 data output delay time			100		80	ns
td(E-P7Q)	Port P7 data output delay time			100		80	ns
td(E-P8Q)	Port P8 data output delay time			100		80	ns

Memory expansion mode and microprocessor mode (when wait bit = "1")

Symbol	Parameter	Test conditions	Limits				Unit
			16 MHz		25 MHz		
			Min.	Max.	Min.	Max.	
td(P0A-E)	Port P0 address output delay time	Fig. 58	30		12		ns
td(E-P1Q)	Port P1 data output delay time (BYTE = "L")			70		45	ns
tPXZ(E-P1Z)	Port P1 floating start delay time (BYTE = "L")			5		5	ns
td(P1A-E)	Port P1 address output delay time		30		12		ns
td(P1A-ALE)	Port P1 address output delay time		24		5		ns
td(E-P2Q)	Port P2 data output delay time			70		45	ns
tPXZ(E-P2Z)	Port P2 floating start delay time			5		5	ns
td(P2A-E)	Port P2 address output delay time		30		12		ns
td(P2A-ALE)	Port P2 address output delay time		24		5		ns
td(ϕ 1-HLDA)	HLDA output delay time			50		50	ns
td(ALE-E)	ALE output delay time		4		4		ns
tw(ALE)	ALE pulse width		35		22		ns
td(BHE-E)	BHE output delay time		30		20		ns
td(R/W-E)	R/W output delay time		30		20		ns
td(E- ϕ 1)	ϕ 1 output delay time		0	20	0	18	ns
th(E-P0A)	Port P0 address hold time		25		18		ns
th(ALE-P1A)	Port P1 address hold time (BYTE = "L")		9		9		ns
th(E-P1Q)	Port P1 data hold time (BYTE = "L")		25		18		ns
tPZX(E-P1Z)	Port P1 floating release delay time (BYTE = "L")		25		18		ns
th(E-P1A)	Port P1 address hold time (BYTE = "H")		25		18		ns
th(ALE-P2A)	Port P2 address hold time		9		9		ns
th(E-P2Q)	Port P2 data hold time		25		18		ns
tPZX(E-P2Z)	Port P2 floating release delay time		25		18		ns
th(E-BHE)	BHE hold time		18		18		ns
th(E-R/W)	R/W hold time		18		18		ns
tw(EL)	E pulse width		95		50		ns

MITSUBISHI MICROCOMPUTERS

M37702M2AXXFP, M37702M2BXXFP M37702S1AFP, M37702S1BFP

SINGLE-CHIP 16-BIT CMOS MICROCOMPUTER

Memory expansion mode and microprocessor mode (when wait bit = "0", and external memory area accessed)

Symbol	Parameter	Test conditions	Limits				Unit
			16 MHz		25 MHz		
			Min.	Max.	Min.	Max.	
td(P0A-E)	Port P0 address output delay time	Fig. 58	30		12		ns
td(E-P1Q)	Port P1 data output delay time (BYTE = "L")			70		45	ns
tPXZ(E-P1Z)	Port P1 floating start delay time (BYTE = "L")			5		5	ns
td(P1A-E)	Port P1 address output delay time		30		12		ns
td(P1A-ALE)	Port P1 address output delay time		24		5		ns
td(E-P2Q)	Port P2 data output delay time			70		45	ns
tPXZ(E-P2Z)	Port P2 floating start delay time			5		5	ns
td(P2A-E)	Port P2 address output delay time		30		12		ns
td(P2A-ALE)	Port P2 address output delay time		24		5		ns
td(ϕ 1-HLDA)	HLDA output delay time			50		50	ns
td(ALE-E)	ALE output delay time		4		4		ns
tw(ALE)	ALE pulse width		35		22		ns
td(BHE-E)	BHE output delay time		30		20		ns
td(R/W-E)	R/W output delay time		30		20		ns
td(E- ϕ 1)	ϕ 1 output delay time		0	20	0	18	ns
th(E-P0A)	Port P0 address hold time		25		18		ns
th(ALE-P1A)	Port P1 address hold time (BYTE = "L")		9		9		ns
th(E-P1Q)	Port P1 data hold time (BYTE = "L")		25		18		ns
tPZX(E-P1Z)	Port P1 floating release delay time (BYTE = "L")		25		18		ns
th(E-P1A)	Port P1 address hold time (BYTE = "H")		25		18		ns
th(ALE-P2A)	Port P2 address hold time		9		9		ns
th(E-P2Q)	Port P2 data hold time		25		18		ns
tPZX(E-P2Z)	Port P2 floating release delay time		25		18		ns
th(E-BHE)	BHE hold time		18		18		ns
th(E-R/W)	R/W hold time		18		18		ns
tw(EL)	\bar{E} pulse width		220		130		ns

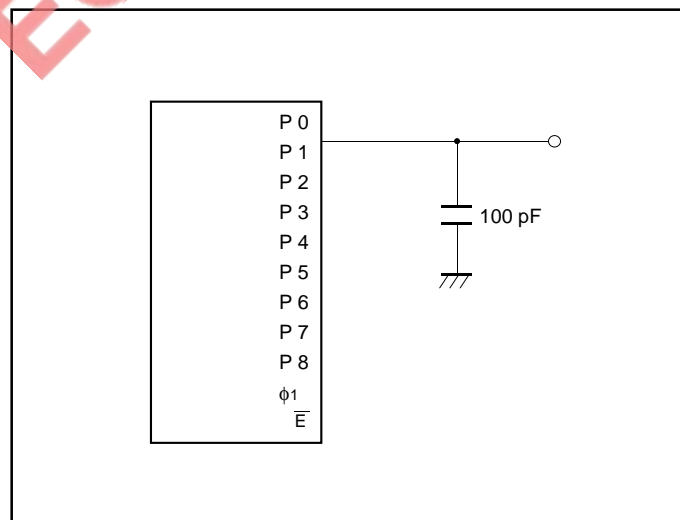

Fig. 58 Testing circuit for ports P0-P8, ϕ 1

**M37702M2AXXFP, M37702M2BXXFP
M37702S1AFP, M37702S1BFP**

SINGLE-CHIP 16-BIT CMOS MICROCOMPUTER

TIMING DIAGRAM

Single-chip mode

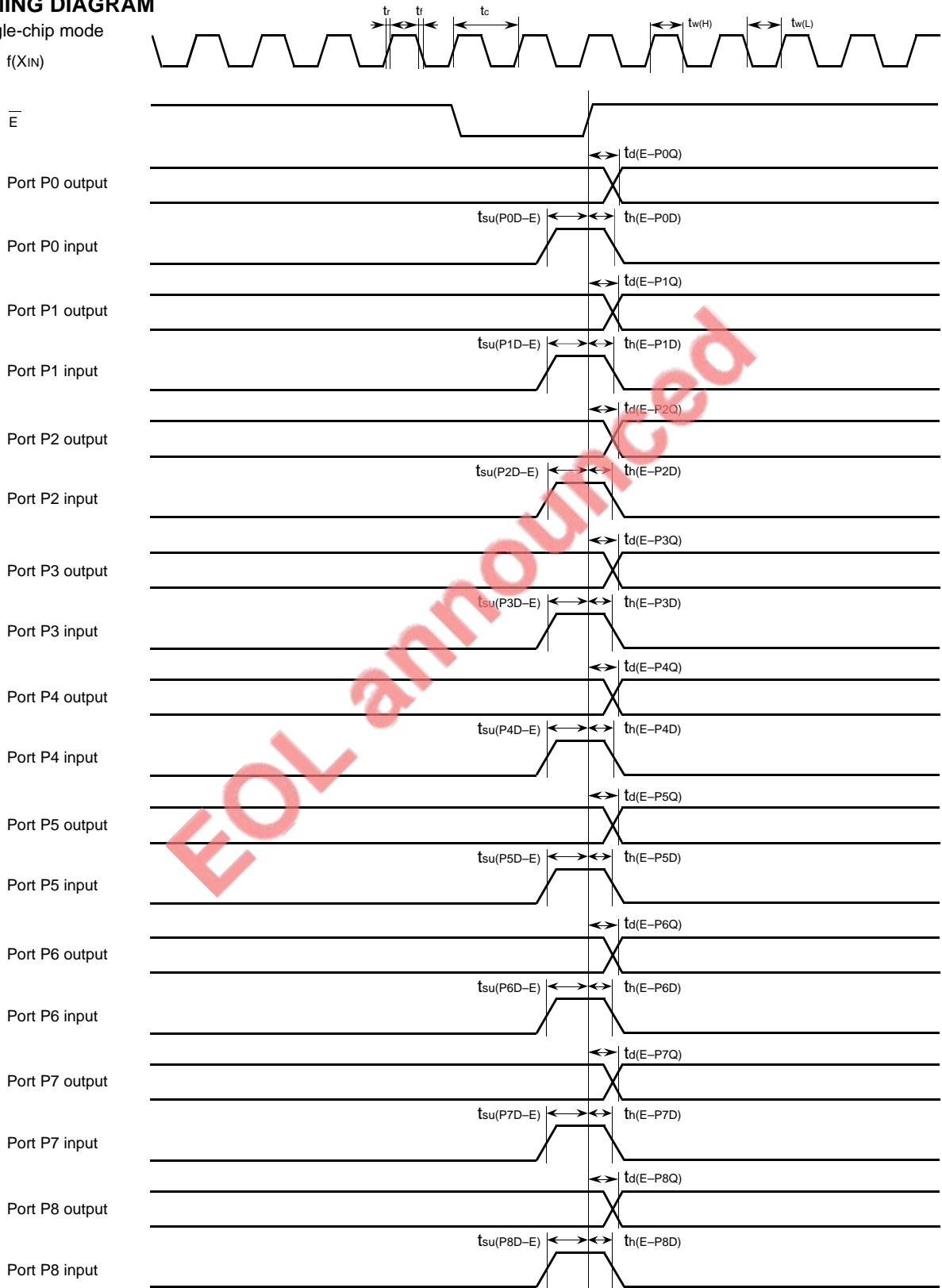

EOL announced

**M37702M2AXXFP, M37702M2BXXFP
M37702S1AFP, M37702S1BFP**

SINGLE-CHIP 16-BIT CMOS MICROCOMPUTER

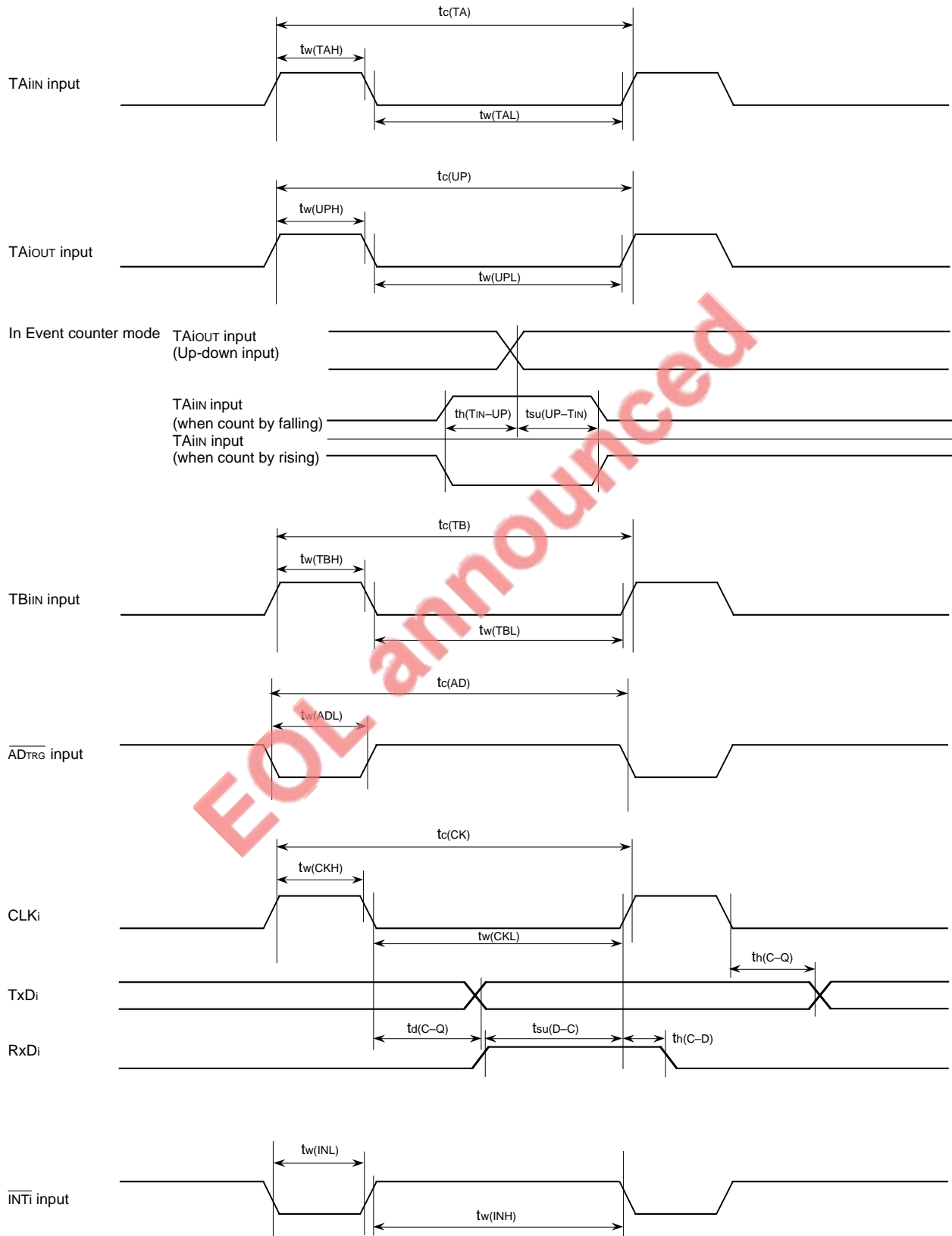

MITSUBISHI MICROCOMPUTERS

M37702M2AXXFP, M37702M2BXXFP M37702S1AFP, M37702S1BFP

SINGLE-CHIP 16-BIT CMOS MICROCOMPUTER

Memory expansion mode and microprocessor mode
(When wait bit = "1")

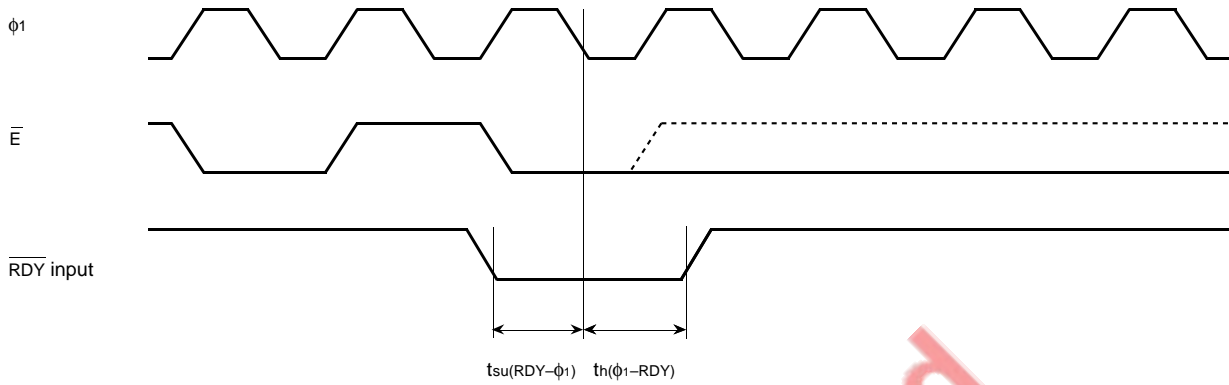

(When wait bit = "0")

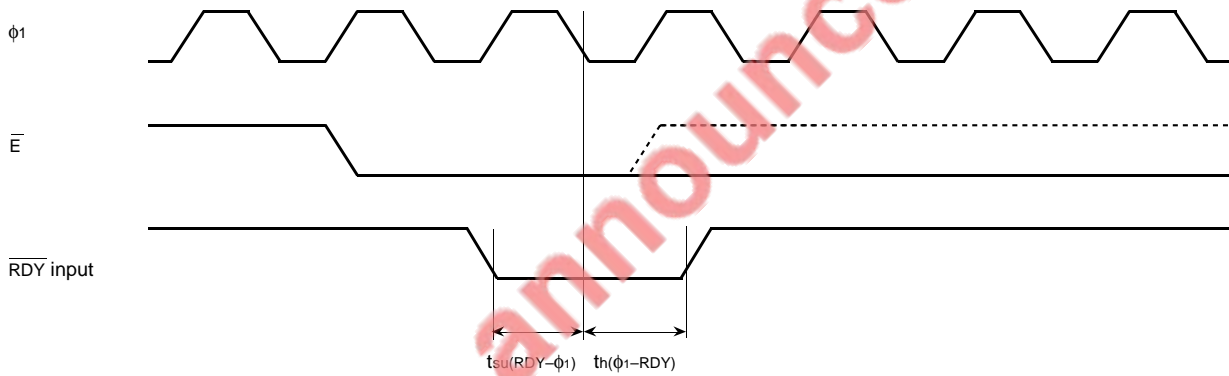

(When wait bit = "1" or "0" in common)

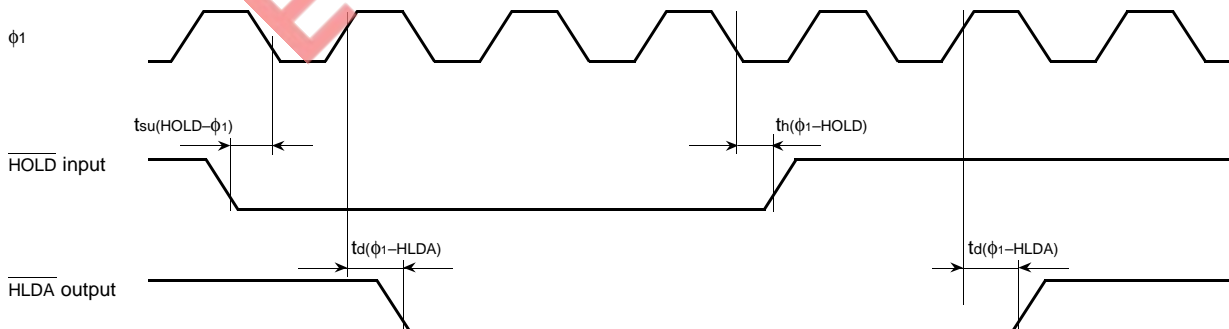

- Test conditions
- $V_{CC} = 5\text{ V} \pm 10\%$
 - Input timing voltage : $V_{IL} = 1.0\text{ V}$, $V_{IH} = 4.0\text{ V}$
 - Output timing voltage : $V_{OL} = 0.8\text{ V}$, $V_{OH} = 2.0\text{ V}$

MITSUBISHI MICROCOMPUTERS
M37702M2AXXXFP, M37702M2BXXFP
M37702S1AFP, M37702S1BFP

SINGLE-CHIP 16-BIT CMOS MICROCOMPUTER

Memory expansion mode and microprocessor mode (When wait bit = "1")

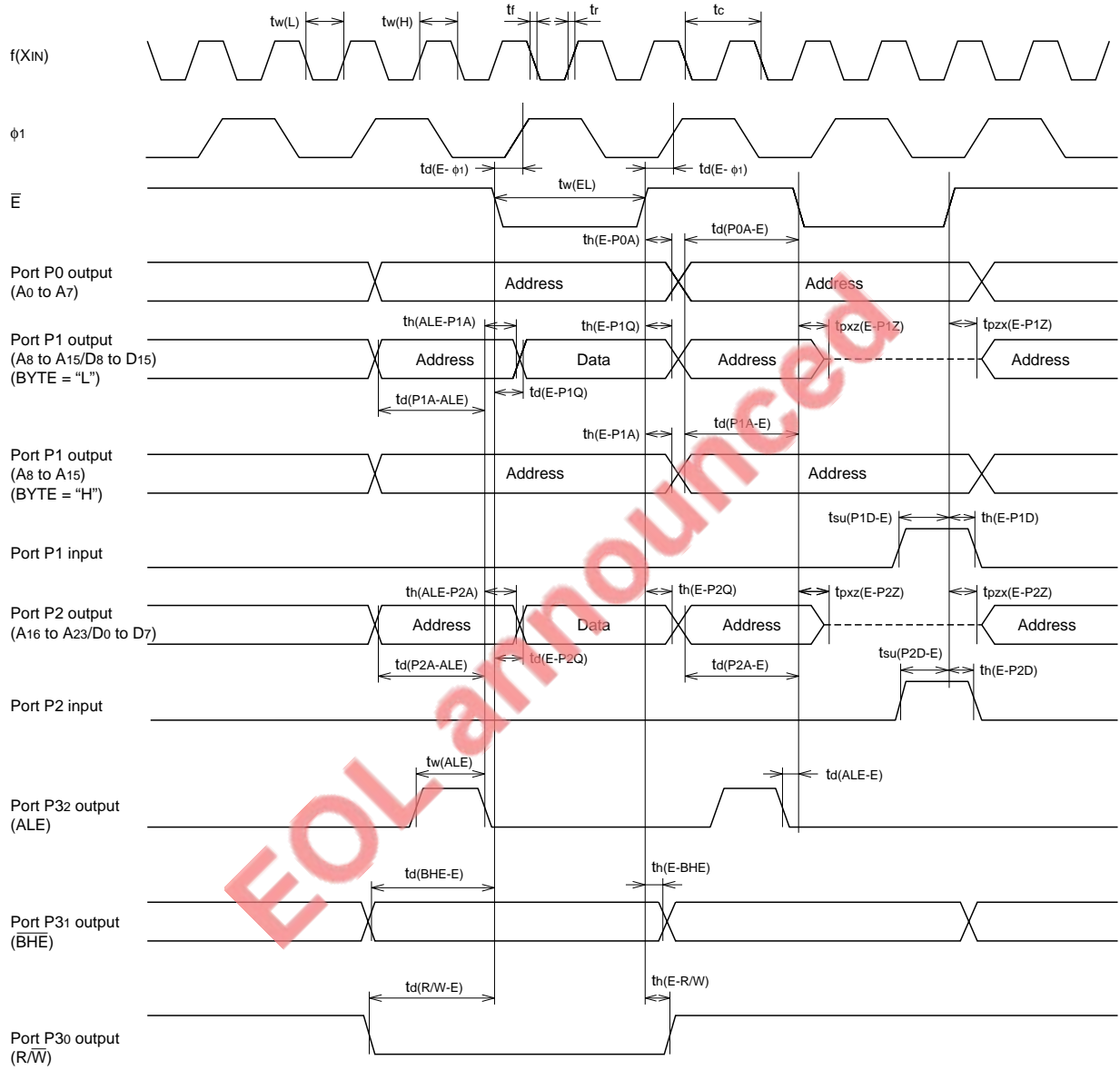

Test conditions

- $V_{CC} = 5\text{ V} \pm 10\%$
- Output timing voltage : $V_{OL} = 0.8\text{ V}$, $V_{OH} = 2.0\text{ V}$
- Ports P1, P2 input : $V_{IL} = 0.8\text{ V}$, $V_{IH} = 2.5\text{ V}$

MITSUBISHI MICROCOMPUTERS

M37702M2AXXFP, M37702M2BXXFP M37702S1AFP, M37702S1BFP

SINGLE-CHIP 16-BIT CMOS MICROCOMPUTER

Memory expansion mode and microprocessor mode (When wait bit = "0", and external memory area is accessed)

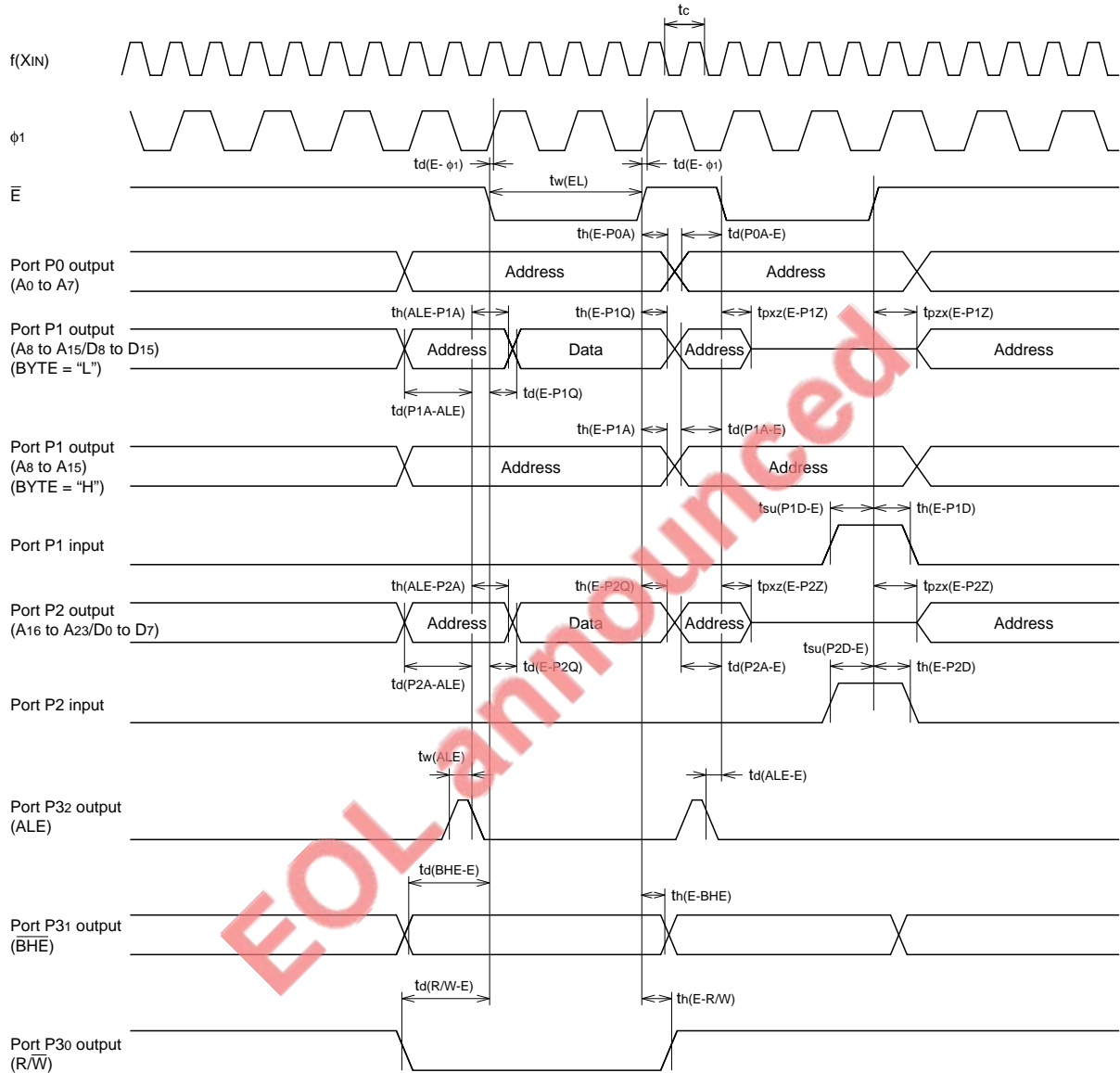

Test conditions

- $V_{CC} = 5\text{ V} \pm 10\%$
- Output timing voltage : $V_{OL} = 0.8\text{ V}$, $V_{OH} = 2.0\text{ V}$
- Ports P1, P2 input : $V_{IL} = 0.8\text{ V}$, $V_{IH} = 2.5\text{ V}$

EOL announced

**MITSUBISHI DATA BOOK
SINGLE-CHIP 16-BIT MICROCOMPUTERS Vol.1**

Mar. First Edition 1996

Edited by
Committee of editing of Mitsubishi Semiconductor Data Book

Published by
Mitsubishi Electric Corp., Semiconductor Division

This book, or parts thereof, may not be reproduced in any form without permission of Mitsubishi Electric Corporation.
©1996 MITSUBISHI ELECTRIC CORPORATION Printed in Japan