

To all our customers

Regarding the change of names mentioned in the document, such as Mitsubishi Electric and Mitsubishi XX, to Renesas Technology Corp.

The semiconductor operations of Hitachi and Mitsubishi Electric were transferred to Renesas Technology Corporation on April 1st 2003. These operations include microcomputer, logic, analog and discrete devices, and memory chips other than DRAMs (flash memory, SRAMs etc.) Accordingly, although Mitsubishi Electric, Mitsubishi Electric Corporation, Mitsubishi Semiconductors, and other Mitsubishi brand names are mentioned in the document, these names have in fact all been changed to Renesas Technology Corp. Thank you for your understanding. Except for our corporate trademark, logo and corporate statement, no changes whatsoever have been made to the contents of the document, and these changes do not constitute any alteration to the contents of the document itself.

Note : Mitsubishi Electric will continue the business operations of high frequency & optical devices and power devices.

Renesas Technology Corp.
Customer Support Dept.
April 1, 2003

PRELIMINARY
 Notice ; This is not a final specification.
 some parametric limits are subject to change.

MITSUBISHI SOUND PROCESSOR

M62421SP/FP

SOUND CONTROLLER

Tone and Volume Controller with 2 Line Control

OUTLINE

M62421SP/FP is the tone and volume controller with 2 line control.
 This IC can apply the broad application because of low noise and distortion.

FEATURE

- TONE(Bass/Treble) control and 1dB step volume control are enabled .
- Low noise and low distortion .
 $V_{NO} = 4.5\mu V_{rms}$, THD=0.1% max
- Controlling by 2 Line serial data .

APPLICATION

- Mini-Stereo , etc

RECOMMENDED OPERATING CONDITION

- Supply voltage range 5.5~9.5V (analog) 4.5~5.5V (digital)
- Rated supply voltage 9V (analog) 5V (digital)

PACKAGE OUTLINE

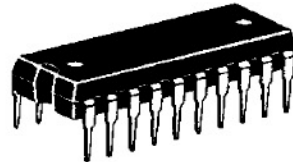

20 P 4 B (SP)

PITCH : 1.78 mm

SIZE : 19.0 mm X 6.3 mm X 3.3 mm

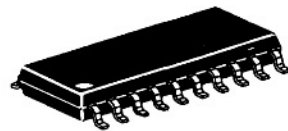

20 P 2 N (FP)

PITCH : 1.27 mm

SIZE : 5.3 mm X 12.6 mm X 1.8 mm

SYSTEM BLOCK DIAGRAM

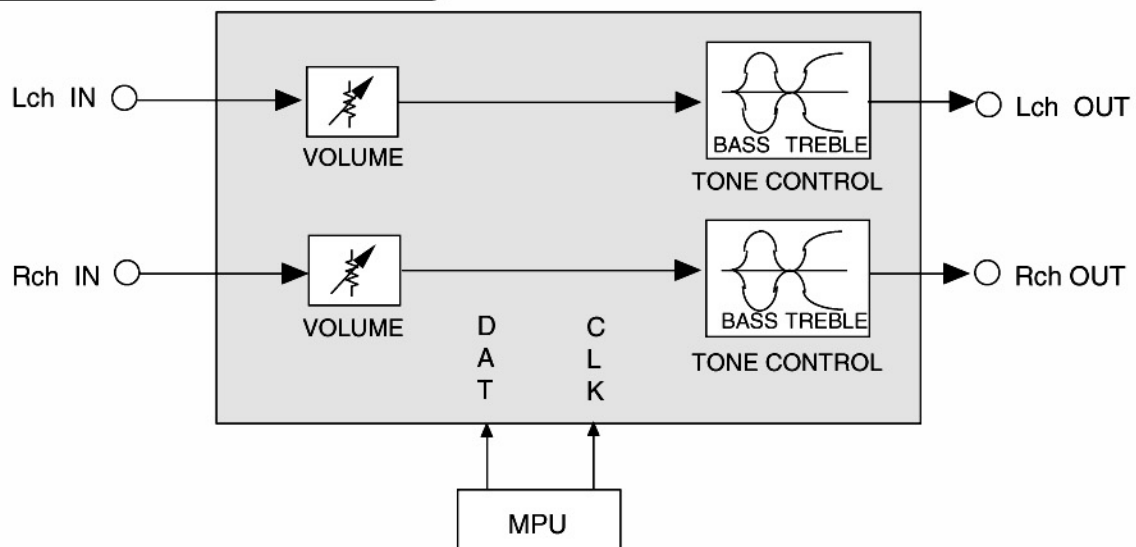

PRELIMINARY
 Notice ; This is not a final specification.
 some parametric limits are subject to change.

MITSUBISHI SOUND PROCESSOR

M62421SP/FP

SOUND CONTROLLER

BLOCK DIAGRAM

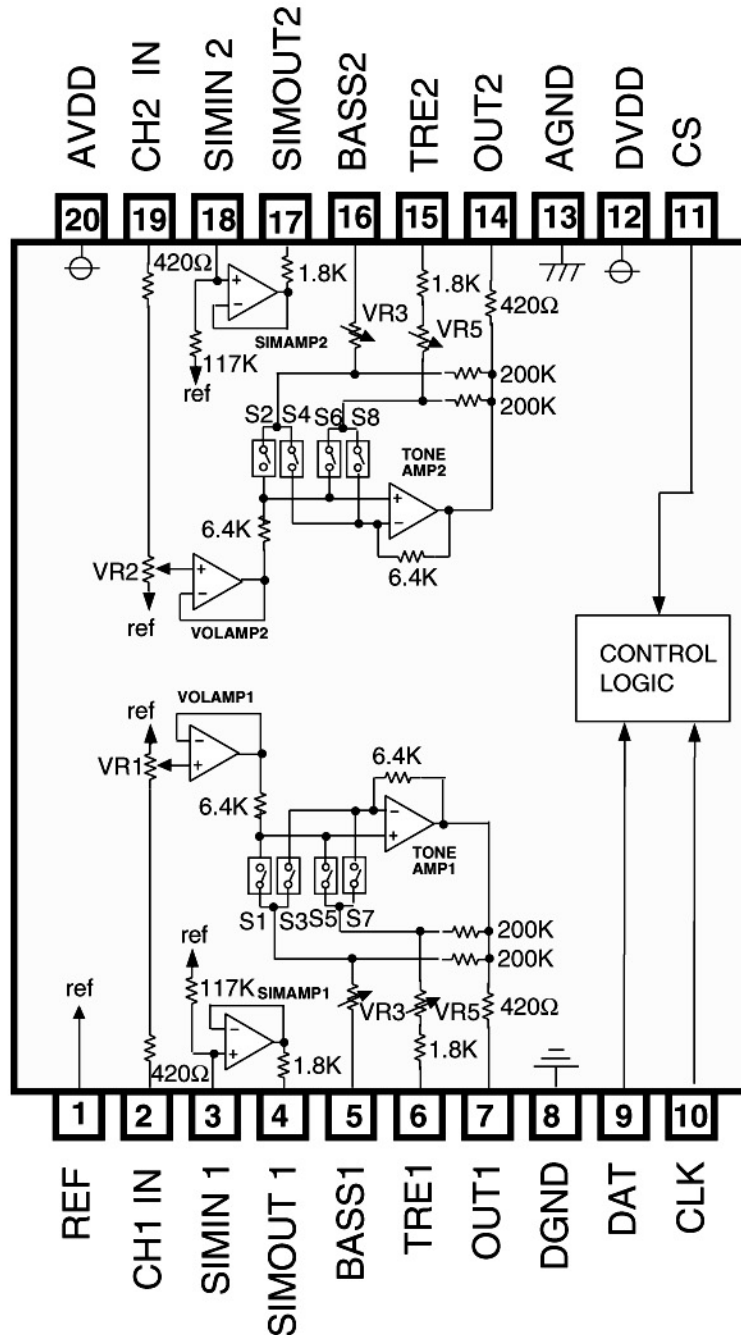

PRELIMINARY
Notice ; This is not a final specification.
some parametric limits are subject to change.

MITSUBISHI SOUND PROCESSOR

M62421SP/FP

SOUND CONTROLLER

PIN DESCRIPTION

PIN No.	PIN NAME	I/O	DESCRIPTION
1	REF	I	Reference voltage terminal for analog
2	CH1 IN	I	Input terminal (ch1)
3	SIMIN 1	I	Pin for capacitor of simulated inductor 1
4	SIMOUT 1	O	Pin for capacitor of simulated inductor 1
5	BASS1	I	Pin for capacitor of ch1-side bass setting
6	TRE1	I	Pin for capacitor of ch1-side treble setting
7	OUT1	O	Output terminal (ch1)
8	DGND	—	Digital GND
9	DAT	I	I/O terminal of DATA 2 line bus format
10	CLK	I	Input terminal of CLOCK 2 line bus format
11	CS	I	Chip select terminal
12	DVDD	—	VDD for digital circuit
13	AGND	—	GND for analog circuit
14	OUT2	O	Output terminal (ch2)
15	TRE2	I	Pin for capacitor of ch2-side treble setting
16	BASS2	I	Pin for capacitor of ch2-side bass setting
17	SIMOUT2	O	Pin for capacitor of simulated inductor 2
18	SIMIN 2	I	Pin for capacitor of simulated inductor 2
19	CH2 IN	I	Input terminal (ch2)
20	AVDD	—	VCC for analog circuit

PRELIMINARY
 Notice ; This is not a final specification.
 some parametric limits are subject to change.

M62421SP/FP

SOUND CONTROLLER

ABSOLUTE MAXIMUM RATINGS

SYMBOL	PARAMETER	CONDITION	LIMITS	UNIT
AVdd	Analog supply voltage		10.0	V
DVdd	Digital supply voltage		7.0	V
Pd	Power dissipation	Ta ≤ 25°C	750(SP) 550(FP)	mW
Kθ	Thermal Derating ratio	Ta > 25°C	7.5(SP) 5.5(FP)	mW/°C
Topr	Operating temperature		-20~+75	°C
Tstg	Storage temperature		-40~+125	°C

Thermal Derating

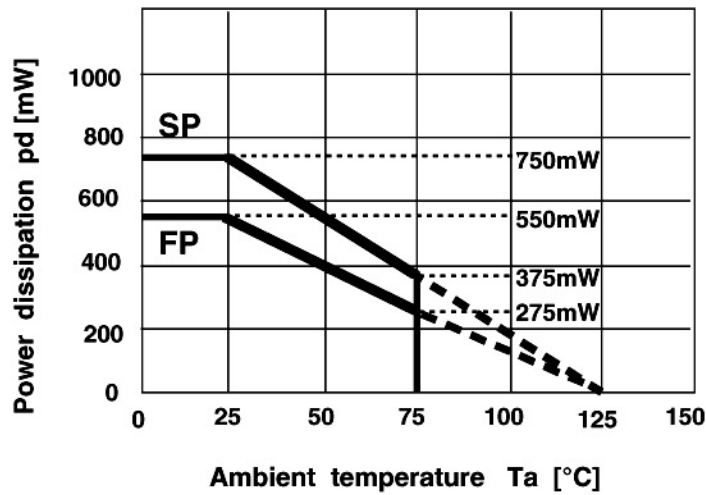

PRELIMINARY
Notice ; This is not a final specification.
some parametric limits are subject to change.

MITSUBISHI SOUND PROCESSOR

M62421SP/FP

SOUND CONTROLLER

RECOMMENDED OPERATING CONDITION

(Ta=25°C unless otherwise noted)

ITEM	SYMBOL	CONDITION	MIN	TYP	MAX	UNIT
Analog supply voltage	AVDD		5.5	9.0	9.5	V
Digital supply voltage	DVDD		4.5	5.0	5.5	V
H level input voltage (logic circuit)	VIH		0.7 DVDD	—	VDD	V
L level input voltage (logic circuit)	VIL		0	—	0.3 DVDD	V

PRELIMINARY
 Notice ; This is not a final specification.
 some parametric limits are subject to change.

M62421SP/FP

SOUND CONTROLLER

ELECTRIC CHARACTERISTICS

(Ta=25°C, AVDD=9V,DVDD=5V and bass and treble=0dB
 unless otherwise noted)

(1) SUPPLY VOLTAGE

ITEM	SYMBOL	CONDITION	LIMIT			UNIT
			Min	typ	Max	
Analog supply current	Icc	•AVdd=9.0V •measure terminal=20 pin •no signal input	—	10	20	mA
Digital supply current	Idd	•DVdd= 5V •measure terminal=12 pin •no signal input	—	0	2	μA

(2) I / O CHARACTERISTICS

ITEM	SYMBOL	CONDITION	LIMIT			UNIT
			Min	typ	Max	
Maximum input voltage	VIM	2,19pin input,7,14pin output RL=10KΩ, THD=1%,f=1kHz ATT=-6dB	2.0	3.2	—	Vrms
Output voltage	Vodc	7pin,14pin, no signal	4.35	4.5	4.65	V
Gain	Gv	Vin=0dBm,FLAT,f=1kHz 2- 7PIN 19-14PIN gain	-2	0	2	dB
Output noise voltage	Vono	IHF-A filter no signal Rg=10KΩ 7,14pin	—	4.5	10	μ Vrms
Total harmonic distortion	THD	7pin,14pin f=1kHz Vo=0.5Vrms , RL=10KΩ LPF=30kHz	—	0.007	0.1	%
Channel separation	CT	RL=10KΩ S:Vin=1Vrms,f=1kHz M:Rg=10kΩ,IHF-A filter	—	-100	-70	dB

PRELIMINARY
 Notice ; This is not a final specification.
 some parametric limits are subject to change.

MITSUBISHI SOUND PROCESSOR

M62421SP/FP

SOUND CONTROLLER

(3) TONE CHARACTERISTICS

ITEM	SYMBOL	CONDITION	LIMIT			UNIT
			Min	typ	Max	
Tone control gain (bass)	Gbassb	f=100Hz	9	12	15	dB
	Gbassc		-15	-12	-9	dB
Tone control gain (treble)	Gtrebb	f=10KHz	9	12	15	dB
	Gtrebc		-15	-12	-9	dB

(4) VOLUME CHARACTERISTICS

ITEM	SYMBOL	CONDITION	LIMIT			UNIT
			Min	typ	Max	
Maximum attenuation	ATTmax	f=1KHz, Vin=0dBm 2pin~7pin	-108	-100	-80	dB
Minimum attenuation	ATTmin	19pin~14pin gain IHF-A-filter	-1.5	0	1.5	dB

PRELIMINARY
 Notice ; This is not a final specification.
 some parametric limits are subject to change.

M62421SP/FP

SOUND CONTROLLER

FUNCTION EXPLANATION

(1) EQUIVALENT CIRCUIT OF TONE CONTROL

The resonance circuit is able to construct by using built-in amplifier for simulated inductor. (Shows the constant as follow)

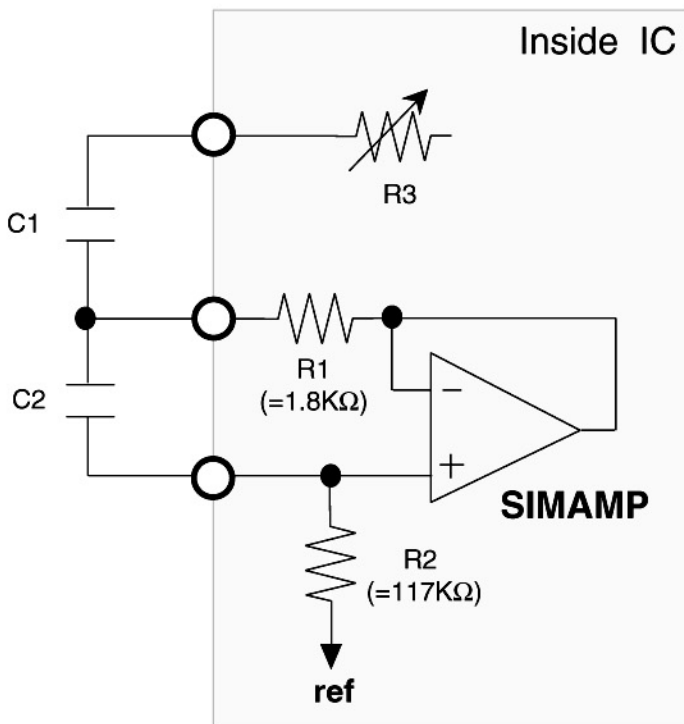

Center frequency

$$f_0 = 1 / 2\pi \sqrt{C1 \cdot C2 \cdot R1 \cdot R2} \text{ [Hz]}$$

$$Q = \sqrt{(C2 \cdot R2) / (C1 \cdot R1)}$$

(EX) BASS band ($f \approx 100\text{Hz}$)
 $R1=1.8\text{K}\Omega$, $R2=117\text{K}\Omega$
 $C1=0.47\mu$, $C2=0.022\mu$

FIG1. The circuit used simulated inductor.

FIG1 is equal to FIG2.
 The following relation is concluded.

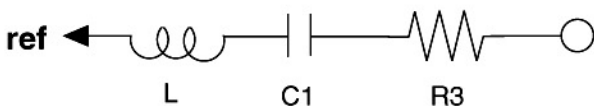

$$L=C2 \cdot ER1 \cdot ER2$$

FIG2. The equivalent circuit used L.

PRELIMINARY
 Notice ; This is not a final specification.
 some parametric limits are subject to change.

MITSUBISHI SOUND PROCESSOR

M62421SP/FP

SOUND CONTROLLER

INPUT DATA FORMAT

← Input direction

D0	D1	D2	D3	D4	D5	D6	D7	D8	D9	D10	D11	D12
0/1	0/1	VOLUME							0/1	0	0	0/1
	TREBLE	BASS				1	1	1	0			

0: BOTH
 1: ONLY 1CHANNEL

These functions are effective only VOLUME data.

0: 1ch
 1: 2ch

0: MUTE OFF
 1: MUTE ON

DATA SELECT
 0: VOLUME/MUTE
 1: BASS/TREBLE

If CS PIN(15 PIN) is "L" → 0,
 and if "H" → 1.

PRELIMINARY
 Notice ; This is not a final specification.
 some parametric limits are subject to change.

M62421SP/FP

SOUND CONTROLLER

(3) -1: volume control

VOLUME CODE

ATT	D2	D3	D4	D5	D6
0dB	H	L	H	L	H
-4dB	L	L	H	L	H
-8dB	H	H	L	L	H
-12dB	L	H	L	L	H
-16dB	H	L	L	L	H
-20dB	L	L	L	L	H
-24dB	H	H	H	H	L
-28dB	L	H	H	H	L
-32dB	H	L	H	H	L
-36dB	L	L	H	H	L
-40dB	H	H	L	H	L
-44dB	L	H	L	H	L
-48dB	H	L	L	H	L
-52dB	L	L	L	H	L
-56dB	H	H	H	L	L
-60dB	L	H	H	L	L
-64dB	H	L	H	L	L
-68dB	L	L	H	L	L
-72dB	H	H	L	L	L
-76dB	L	H	L	L	L
-80dB	H	L	L	L	L
-∞dB	L	L	L	L	L

ATT	D7	D8
0dB	H	H
-1dB	L	H
-2dB	H	L
-3dB	L	L

PRELIMINARY
 Notice ; This is not a final specification.
 some parametric limits are subject to change.

M62421SP/FP

SOUND CONTROLLER

(4) -2 : tone level control

TONE CODE

	BASS				TREBLE			
	D7	D6	D5	D4	D3	D2	D1	D0
12dB	L	H	H	L	L	H	H	L
10dB	L	H	L	H	L	H	L	H
8dB	L	H	L	L	L	H	L	L
6dB	L	L	H	H	L	L	H	H
4dB	L	L	H	L	L	L	H	L
2dB	L	L	L	H	L	L	L	H
0dB	L	L	L	L	L	L	L	L
-2dB	H	L	L	H	H	L	L	H
-4dB	H	L	H	L	H	L	H	L
-6dB	H	L	H	H	H	L	H	H
-8dB	H	H	L	L	H	H	L	L
-10dB	H	H	L	H	H	H	L	H
-12dB	H	H	H	L	H	H	H	L

NOT USED HHHH
 LHHH
 HLLL

(3) -3 : MUTE CONTROL

On condition D9=1,MUTE can be set up.
 In MUTE,VOLUME LEVEL is set up VOL=-∞
 automatically.

PRELIMINARY
Notice ; This is not a final specification.
some parametric limits are subject to change.

MITSUBISHI SOUND PROCESSOR

M62421SP/FP

SOUND CONTROLLER

DATA and CLOCK

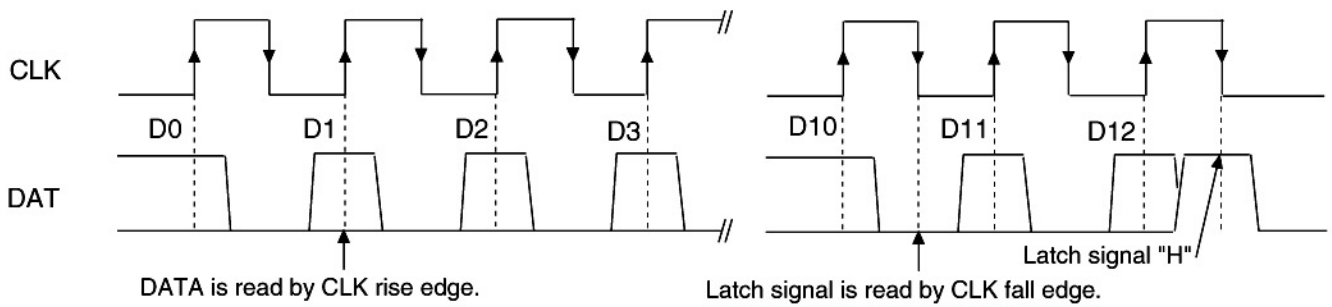

PRELIMINARY
 Notice ; This is not a final specification.
 some parametric limits are subject to change.

MITSUBISHI SOUND PROCESSOR

M62421SP/FP

SOUND CONTROLLER

BUS LINE TIMING SPECIFICATION

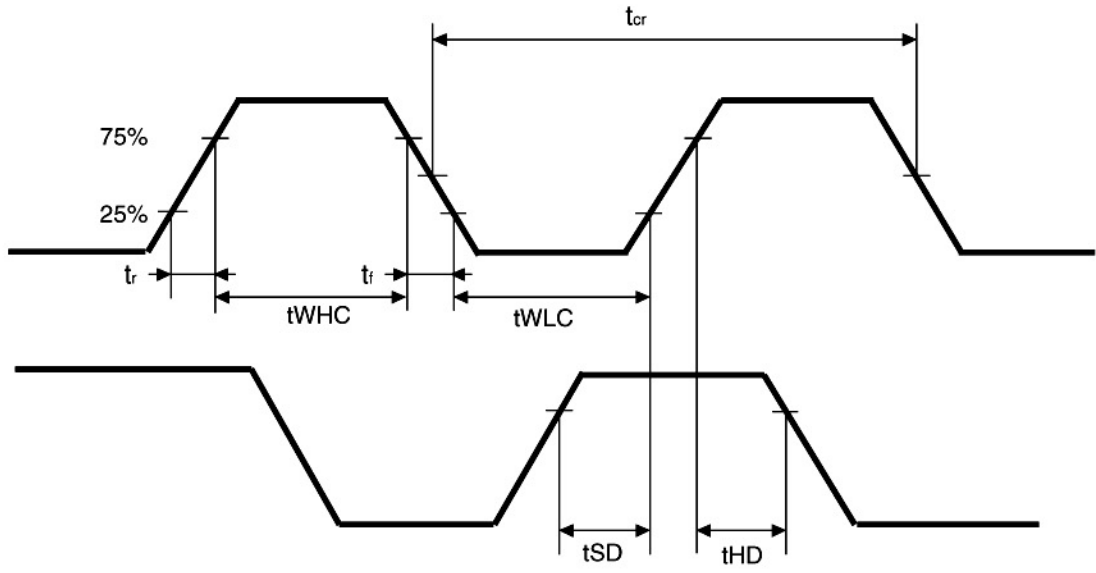

Parameter	Symbol	MIN	MAX	Units
CLK clock frequency	t_{cr}	4	-	μs
The HIGH period of the clock	t_{WHC}	1.6	-	μs
The LOW period of the clock	t_{WLC}	1.6	-	μs
Rise time of CLK line	t_r	-	0.4	μs
Fall time of CLK line	t_f	-	0.4	μs
Set-up time DATA	t_{SD}	0.8	-	μs
Hold time DATA	t_{HD}	0.8	-	μs

PRELIMINARY
 Notice ; This is not a final specification.
 some parametric limits are subject to change.

MITSUBISHI SOUND PROCESSOR

M62421SP/FP

SOUND CONTROLLER

LEVEL DIAGRAM

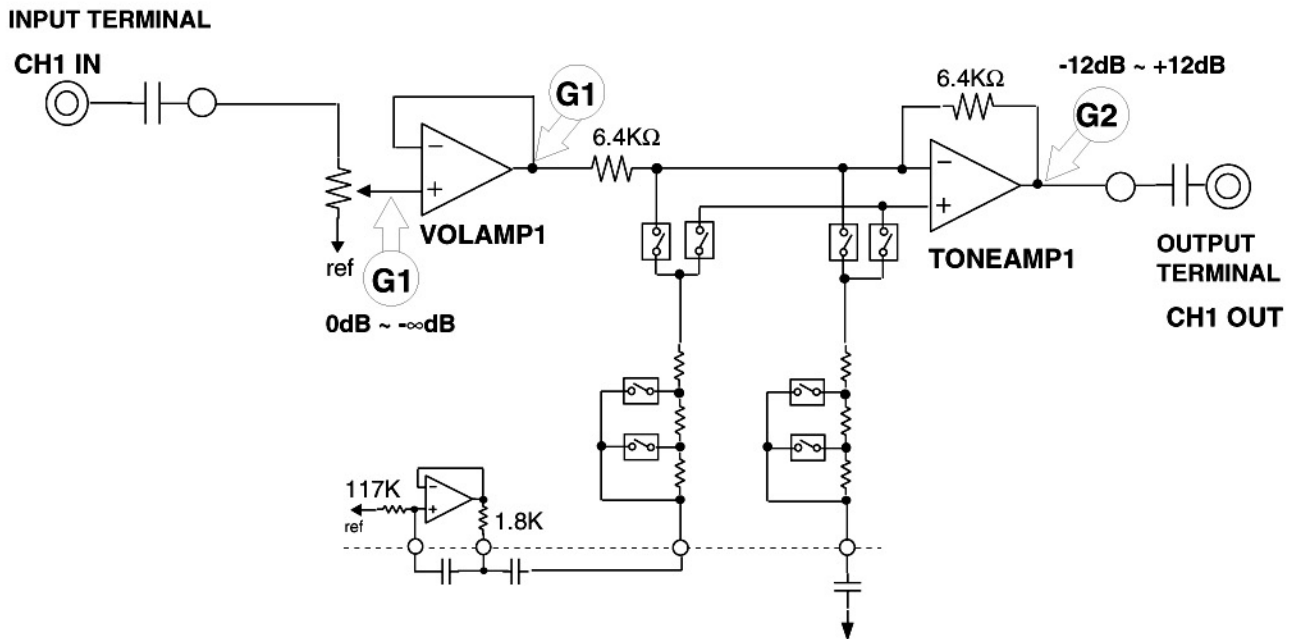

INPUT TERMINAL

CH2 IN

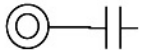

Same to CH 1

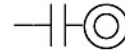

OUTPUT TERMINAL

CH2 OUT

PRELIMINARY
 Notice ; This is not a final specification.
 some parametric limits are subject to change.

MITSUBISHI SOUND PROCESSOR

M62421SP/FP

SOUND CONTROLLER

LOGIC CIRCUIT

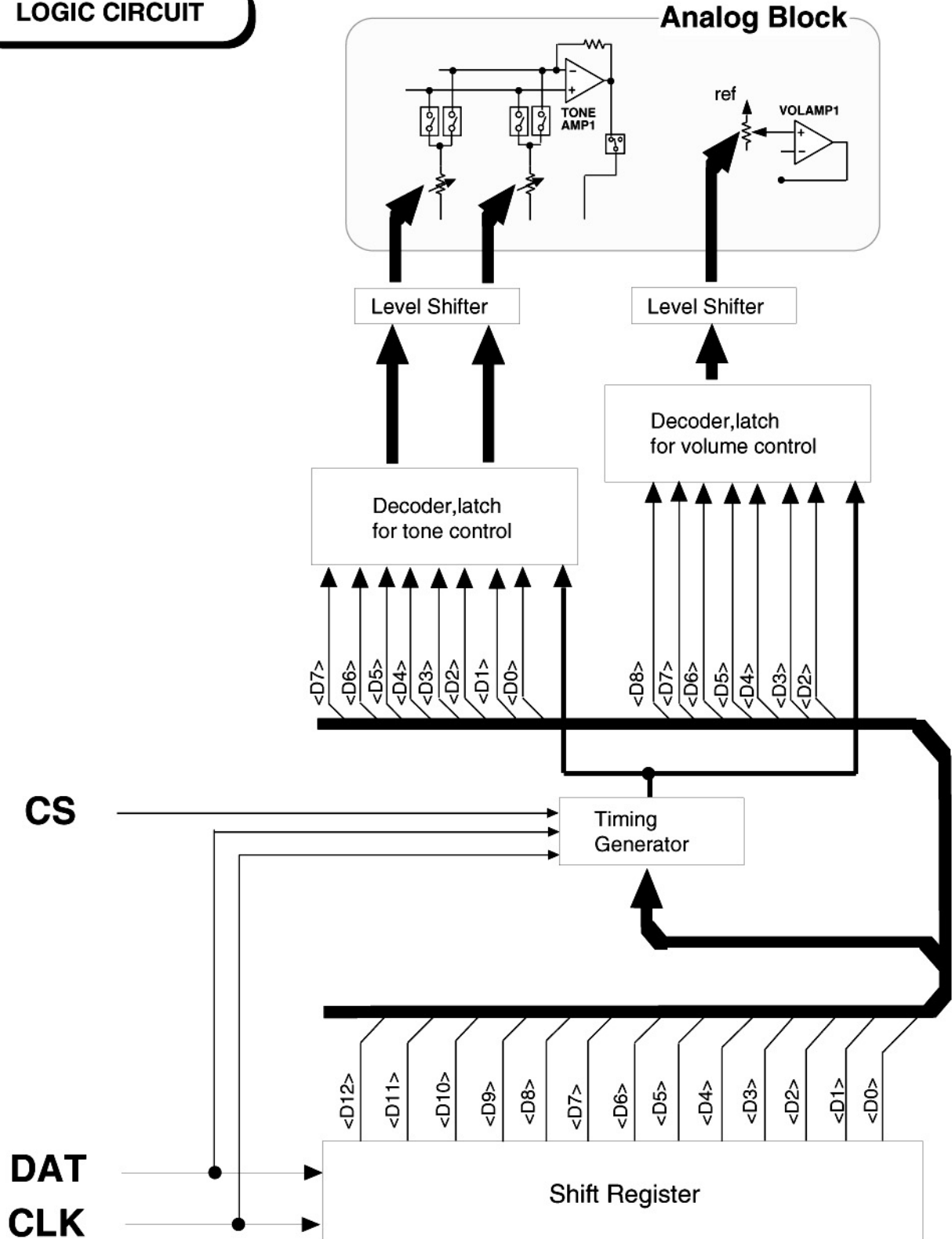

PRELIMINARY
 Notice ; This is not a final specification.
 some parametric limits are subject to change.

MITSUBISHI SOUND PROCESSOR

M62421SP/FP

SOUND CONTROLLER

APPLICATION EXAMPLE

