

To all our customers

Regarding the change of names mentioned in the document, such as Mitsubishi Electric and Mitsubishi XX, to Renesas Technology Corp.

The semiconductor operations of Hitachi and Mitsubishi Electric were transferred to Renesas Technology Corporation on April 1st 2003. These operations include microcomputer, logic, analog and discrete devices, and memory chips other than DRAMs (flash memory, SRAMs etc.) Accordingly, although Mitsubishi Electric, Mitsubishi Electric Corporation, Mitsubishi Semiconductors, and other Mitsubishi brand names are mentioned in the document, these names have in fact all been changed to Renesas Technology Corp. Thank you for your understanding. Except for our corporate trademark, logo and corporate statement, no changes whatsoever have been made to the contents of the document, and these changes do not constitute any alteration to the contents of the document itself.

Note : Mitsubishi Electric will continue the business operations of high frequency & optical devices and power devices.

Renesas Technology Corp.
Customer Support Dept.
April 1, 2003

PRELIMINARY
 Notice ; This is not a final specification.
 some parametric limits are subject to change.



MITSUBISHI ELECTRIC

M62437FP

SOUND CONTROLLER WITH
 SRS FOCUS & SRS SURROUND

SRS F(●)cus, SRS 3D Stereo Sound Controller

DESCRIPTION

- This is an IC for car audio.
- F(●)cus system can realize more optimal speaker position.

FEATURE

- Built-in F(●)cus [LF/HF elevation(position) and Bass Compensation can be changed by the external resistors.]
- Built-in SR
- SRS ON/OFF mode and FOCUS ON/OFF mode can be controlled by the DC voltage.



42P2R

RECOMMENDED OPERATING CONDITION

Supply voltage range.....Vcc=7 ~ 9V

Rated supply voltage.....Vcc=8V

SYSTEM BLOCK DIAGRAM

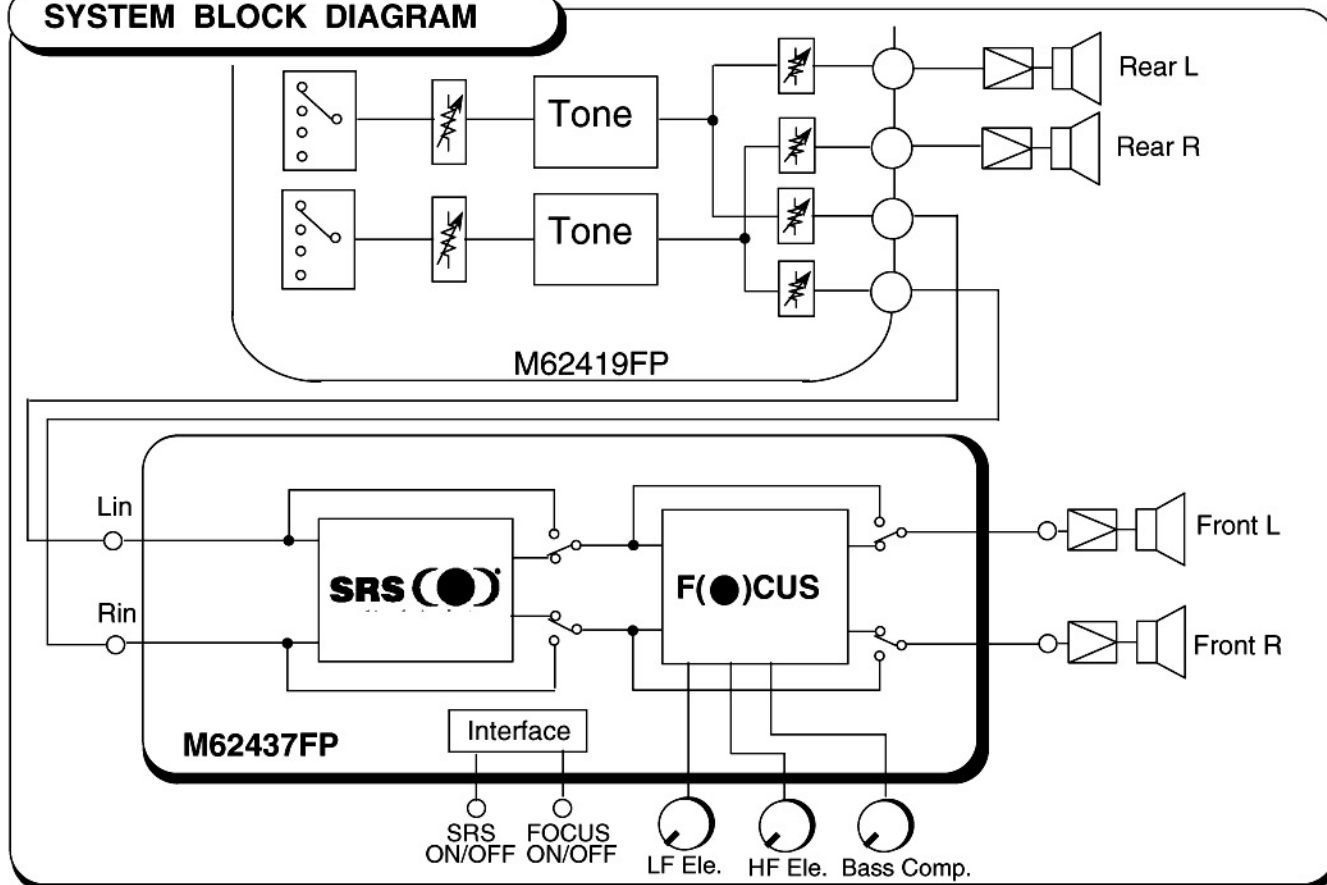

Block Diagram & Application Example

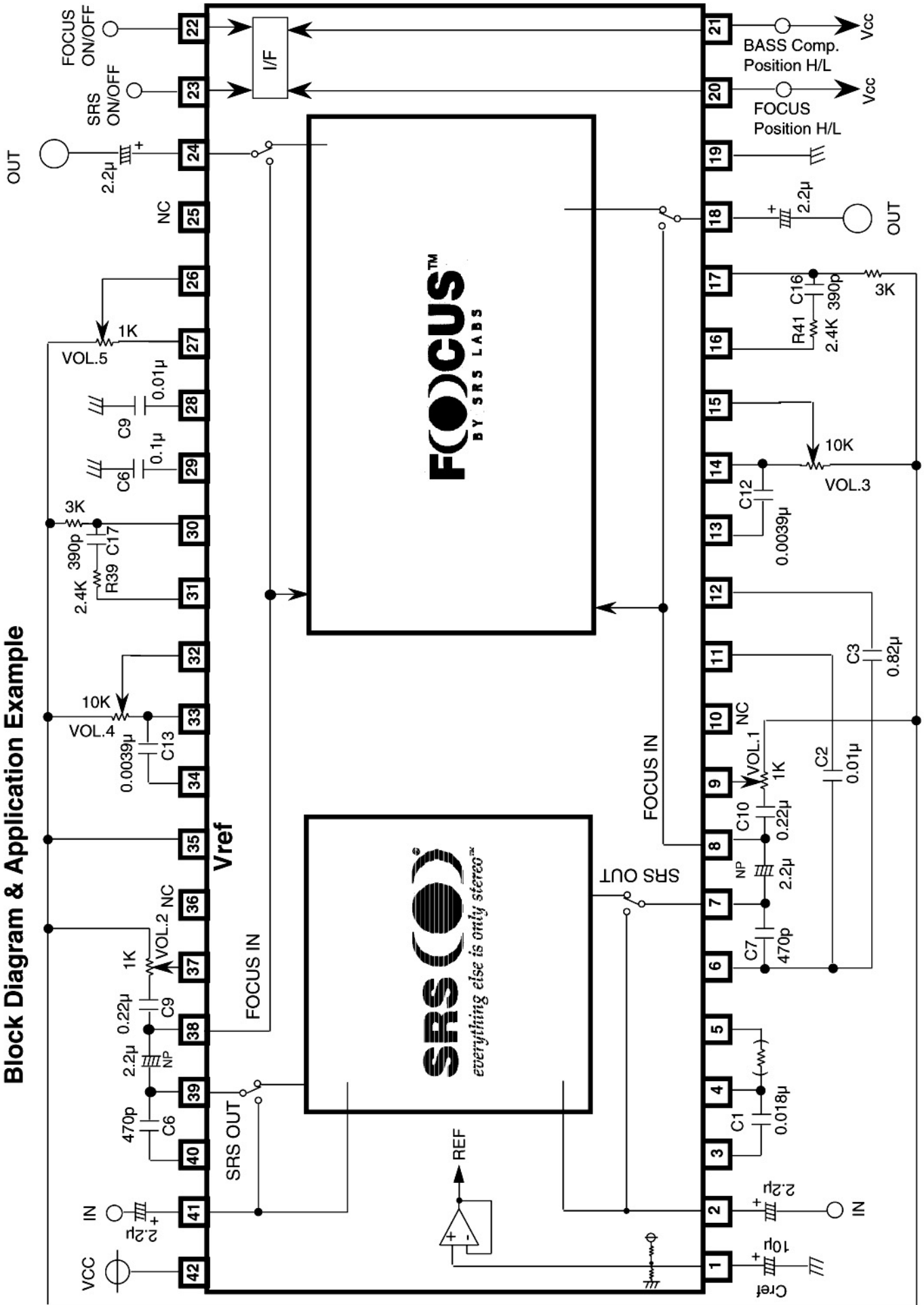

ABSOLUTE MAXIMUM RATINGS

Symbol	Parameter	Conditions	Ratings	Unit
Vcc,Vdd	Supply Voltage		12	V
Pd	Power Dissipation	Ta≤25	990	mW
K _θ	Thermal Derating	Ta>25	9.9	mW/°C
T _{opr}	Operating Temperature		-20 ~ +75	°C
T _{stg}	Storage Temperature		-55 ~ + 125	°C

Thermal Derating

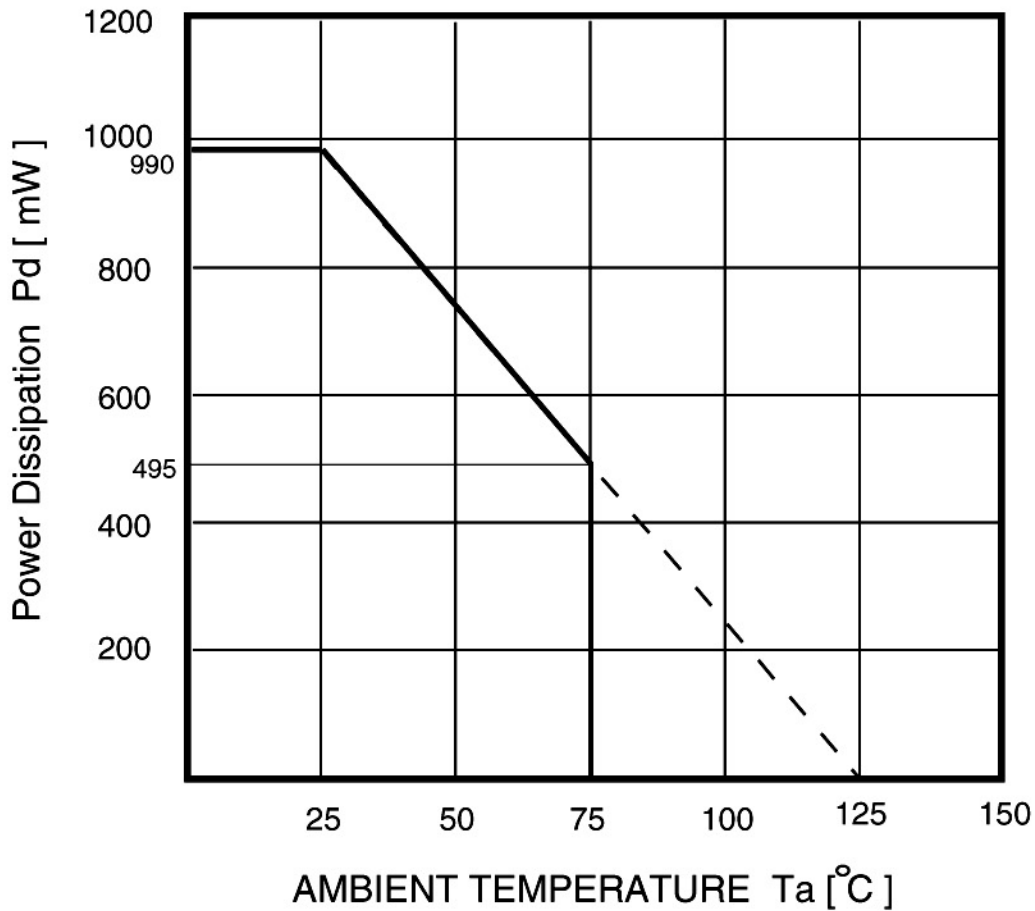

ELECTRICAL CHARACTERISTICS

(1) Power Supply Characteristics (Ta=25°C, Vcc=8.0V, f=1kHz)

Parameter	Symbol	Conditions	Limit			Unit
			Min	typ	Max	
Circuit Current	Icc	42pin Icc No Signal	—	25	45	mA

(2) Input / Output Characteristics

(Ta=25°C, Vcc=8.0V, f=1kHz
VOL.1,2=1KΩ(VOL), VOL.3,4=10KΩ(VOL)
VOL.5=1KΩ(VOL))

Parameter	Symbol	Conditions	Limit			Unit	
			Min	typ	Max		
Maximum Output Voltage	VOMt	Input; pin2,41 Output; pin18, 24 RL =10KΩ, THD=1%	1.6	1.9	-	Vrms	
Maximum Input Voltage	VIM1	Input; pin2,41 /Output; pin18, 24 SRS → ON, FOCUS → OFF THD=1%	f=150Hz	0.4	0.6	-	Vrms
	VIM2	Input; pin2,41 /Output; pin18, 24 SRS → ON FOCUS → ON(All VOL.=max) THD=1%	f=1KHz	0.2	0.3	-	
	VIM3		f=20KHz	0.06	0.11	-	
Pass Gain	Gvt	Vi=100mVrms SRS, Focus → OFF Input; pin2,41 /Output; pin18, 24		-2.0	0	2.0	dB
	Gv1	Vi=100mVrms Input; pin2,41 /Output; pin18, 24 SRS → ON, FOCUS → OFF	f=150Hz	7	10	13	
	Gv2	Vi=100mVrms SRS → ON FOCUS → ON(All VOL.=max) (2pin,41pin)-(18, 24Pin)	f=1KHz	15	18	21	
	Gv3		f=20KHz	25	28	31	
Output Noise Voltage	Vno1	Rg=0(2,41pin) SRS → OFF, FOCUS → OFF DIN-AUDIO filter		-	5.5	15	μVrms
	Vno2	Rg=0(2,41pin) SRS → ON, FOCUS → OFF DIN-AUDIO filter		-	18	50	
	Vno3	Rg=0(2,41pin), SRS → ON, FOCUS → ON(All VOL.=max) DIN-AUDIO filter		-	90	150	
Channel Separation	CT	Input Side: f=1KHz, Vi=0.5Vrms Monitor Side: Rg=0, IHF-A filter Focus: OFF, SRS: OFF RL=10KΩ		-	-90	-75	dB

(3) DC Control Characteristic of the Switch Block

Symbol	Parameter	Condition	Limit			Unit
			Min	typ	Max	
V_{IH}	"H" Level Input Voltage	Pin 22,23	2.1	~	Vcc	V
V_{IL}	"L" Level Input Voltage	Pin 22,23	0	~	0.8	V

Switch Condition and the Mode

②③ SRS 3D Stereo	SRS ON/OFF Switch
SRS ON	H
SRS OFF	L

②② FOCUS	FOCUS ON/OFF Switch
FOCUS ON	H
FOCUS OFF	L

*Bypass mode can be set by both SRS ON/OFF switch and FOCUS ON/OFF switch are set to "L".

[For Example]The other Application Circuit

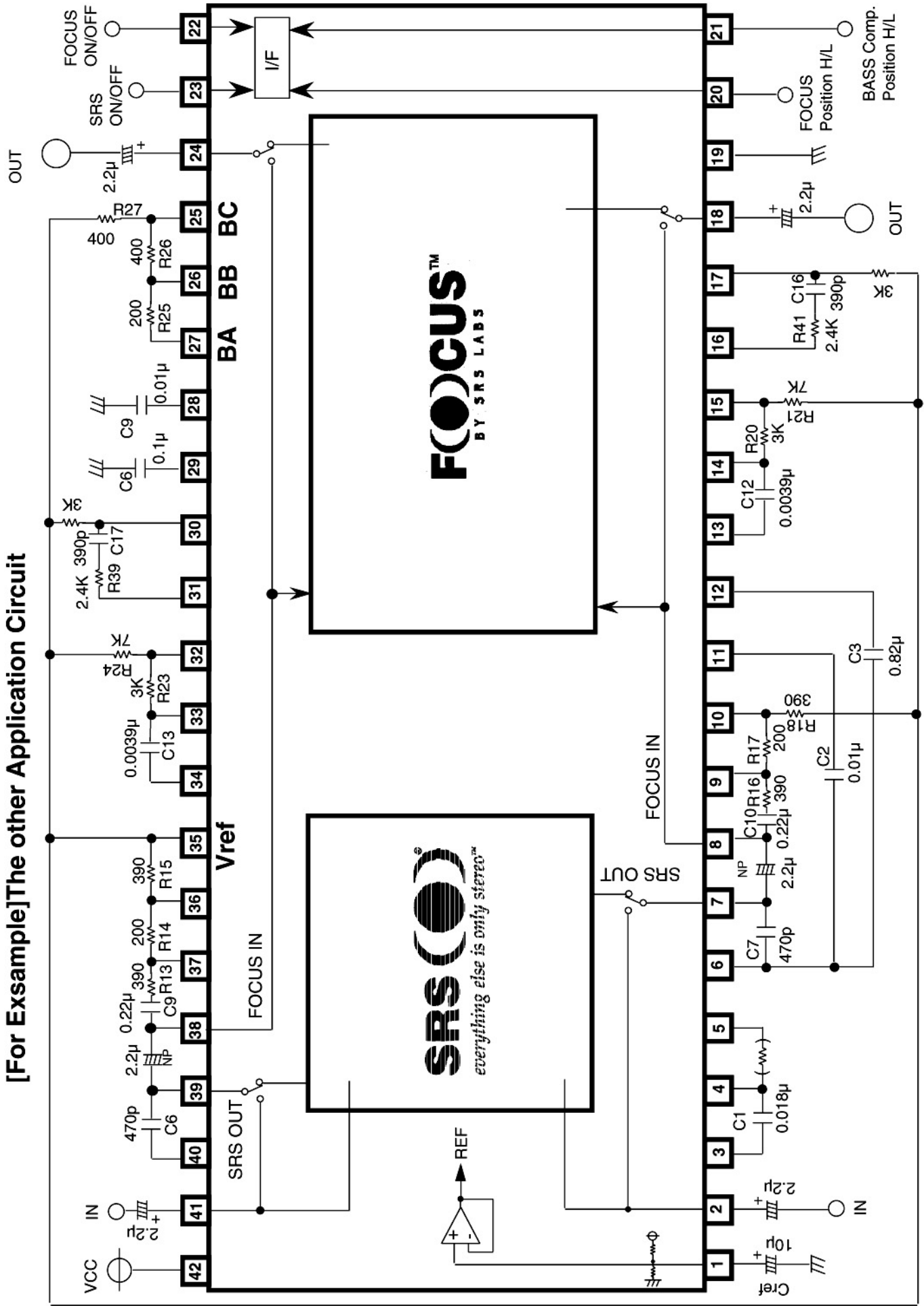

Regarding to the other Application Circuit

● R16(R13),R17(R14),R18(R15)

The resistors of R16(R13),R17(R14),R18(R15) can be set the FOCUS position(LF Elevation).

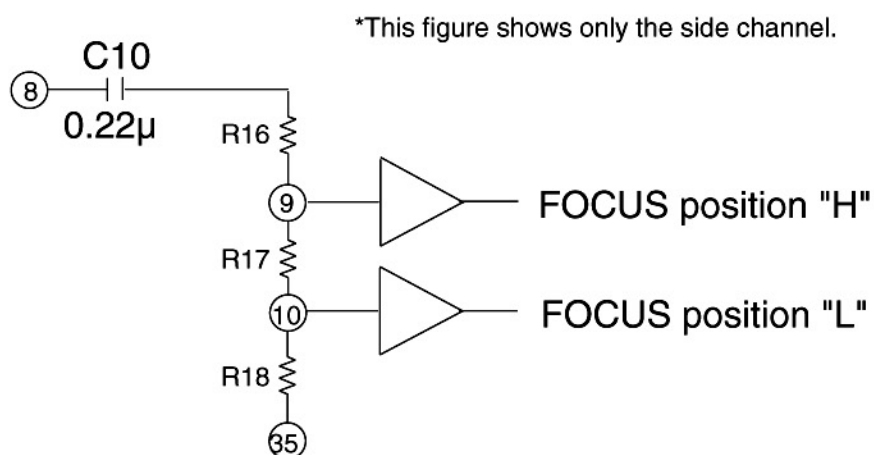

1. The setting of the FOCUS position "H"

$$\frac{R17 + R18}{R16 + R17 + R18}$$

2. The setting of the FOCUS position "L"

$$\frac{R18}{R16 + R17 + R18}$$

*please keep the following formula.

$$R16 + R17 + R18 \cong 1K\Omega$$

(Example) In the case of $R16 = 390\Omega$, $R17 = 200\Omega$, $R18 = 390\Omega$

FOCUS position "H" \cong 60%

FOCUS position "L" \cong 40%

(SwitchSetting)

	FOCUS ON/OFF Switch(22Pin)	FOCUS Position H/L Switch(20Pin)
FOCUS Position "H" (LF Elevation)	H	H
FOCUS Position "L" (LF Elevation)	H	L

● R20(R23),R21(R24)

The resistors of R20(R23),R21(R24)can be set the HF Elevation.

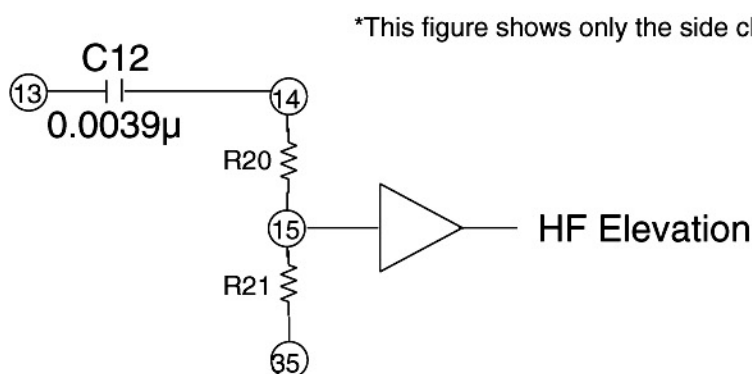

1. The setting of the HF Elevation.

$$\frac{R21}{R20 + R21}$$

*please keep the following formula.

$$R20+R21 \doteq 10K\Omega$$

(Example)

In the case of $R20 = 3K\Omega, R21 = 7K\Omega$

$$HF \text{ Elevation} \doteq 70\%$$

● R25,R26,R27

The resistors of R25,R26,R27 can be set the Bass Compensation.

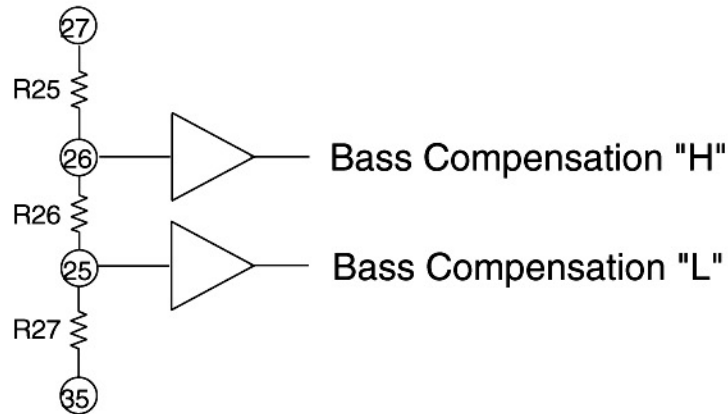

1. The setting of the Bass Compensation "H"

$$\frac{R26 + R27}{R25 + R26 + R27}$$

2. The setting of the Bass Compensation "L"

$$\frac{R27}{R25 + R26 + R27}$$

*please keep the following formula.

$$R25+R26+R27 \doteq 1K\Omega$$

(Example) In the case of R25 = 200Ω,R26 = 390Ω,R27 = 390Ω

Bass Compensation "H"≐ 80%

Bass Compensation "L"≐ 40%

(SwithSetting)

	FOCUS ON/OFF Switch(22Pin)	Bass Comp. H/L Switch(21Pin)
Bass Compensation "H"	H	H
Bass Compensation "L"	H	L

Between Pin16(31) and Pin17(30)

Add 10K of resistors between Pin16(31) and Pin17(30), can adjust the difference between the sound level of Focus ON and the sound level of Focus OFF.

Also add 10K of resistors between Pin16(31) and Pin17(30), can decrease the Focus gain.

Then the maximum input voltage and the output noise voltage can be improved.

(Reference)

In the case of (VOL.1,2=1K Ω , VOL.3,4=10K Ω , VOL.5=1K Ω)
 (Add 10K Ω of resistors between Pin16(31) and Pin17(30))

Parameter	Symbol	Conditions	Typ.	Unit
Maximum Output Voltage	VOMt	Input; pin2,41 Output; pin18, 24 RL =10K Ω , THD=1%	1.9	Vrms
Maximum Input Voltage	VIM1	Input; pin2,41 /Output; pin18, 24 SRS \rightarrow ON, FOCUS \rightarrow OFF THD=1%	f=150Hz 0.6	Vrms
	VIM2	Input; pin2,41 /Output; pin18, 24 SRS \rightarrow ON FOCUS \rightarrow ON(All VOL.=max) THD=1%	f=1KHz 0.55	
	VIM3		f=20KHz 0.2	
Pass Gain	Gvt	Vi=100mVrms SRS, Focus \rightarrow OFF Input; pin2,41 /Output; pin18, 24	0	dB
	Gv1	Vi=100mVrms Input; pin2,41 /Output; pin18, 24 SRS \rightarrow ON, FOCUS \rightarrow OFF	f=150Hz 10	
	Gv2	Vi=100mVrms SRS \rightarrow ON FOCUS \rightarrow ON(All VOL.=max)	f=1KHz 12	
	Gv3	(2pin,41pin)-(18, 24Pin)	f=20KHz 22	
Output Noise Voltage	Vno1	Rg=0(2,41pin) SRS \rightarrow OFF , FOCUS \rightarrow OFF DIN-AUDIO filter	5.5	μ Vrms
	Vno2	Rg=0(2,41pin) SRS \rightarrow ON , FOCUS \rightarrow OFF DIN-AUDIO filter	18	
	Vno3	Rg=0(2,41pin), SRS \rightarrow ON, FOCUS \rightarrow ON(All VOL.=max) DIN-AUDIO filter	50	
Channel Separation	CT	Input Side:f=1KHz, Vi=0.5Vrms Monitor Side:Rg=0, IHF-A filter Focus:OFF, SRS:OFF RL=10K Ω	-90	dB

System Circuit Example

(The following figures show only the side channel.)

1. In the case of SRS 3D stereo is effective for the front speakers.

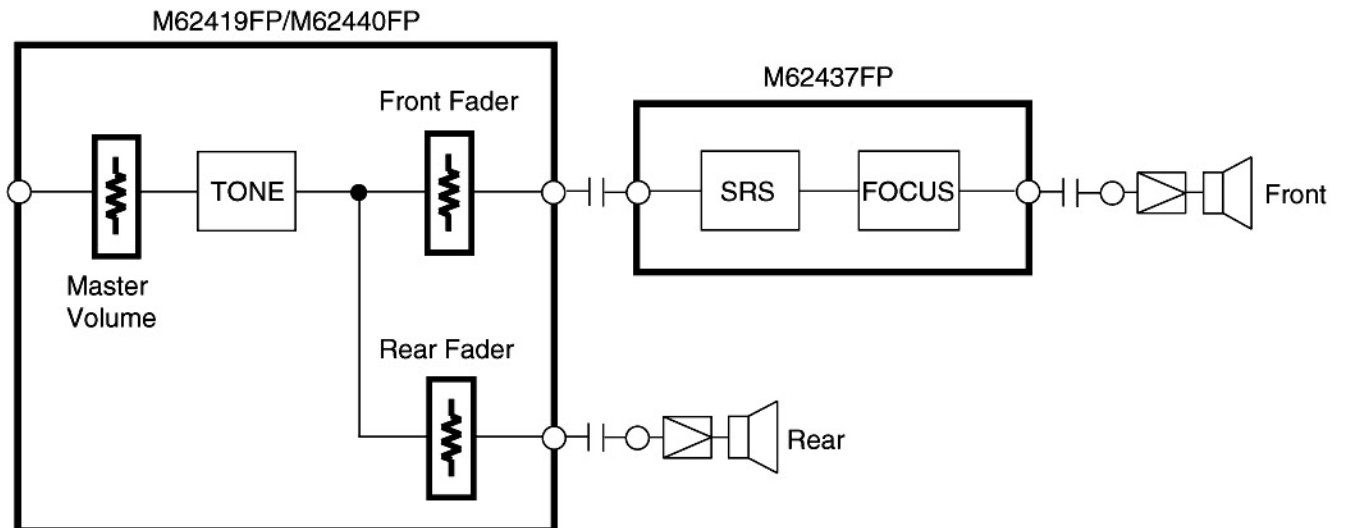

2. In the case of SRS 3D stereo is effective for the front and rear speakers.
(FOCUS is effective for the front speakers.)

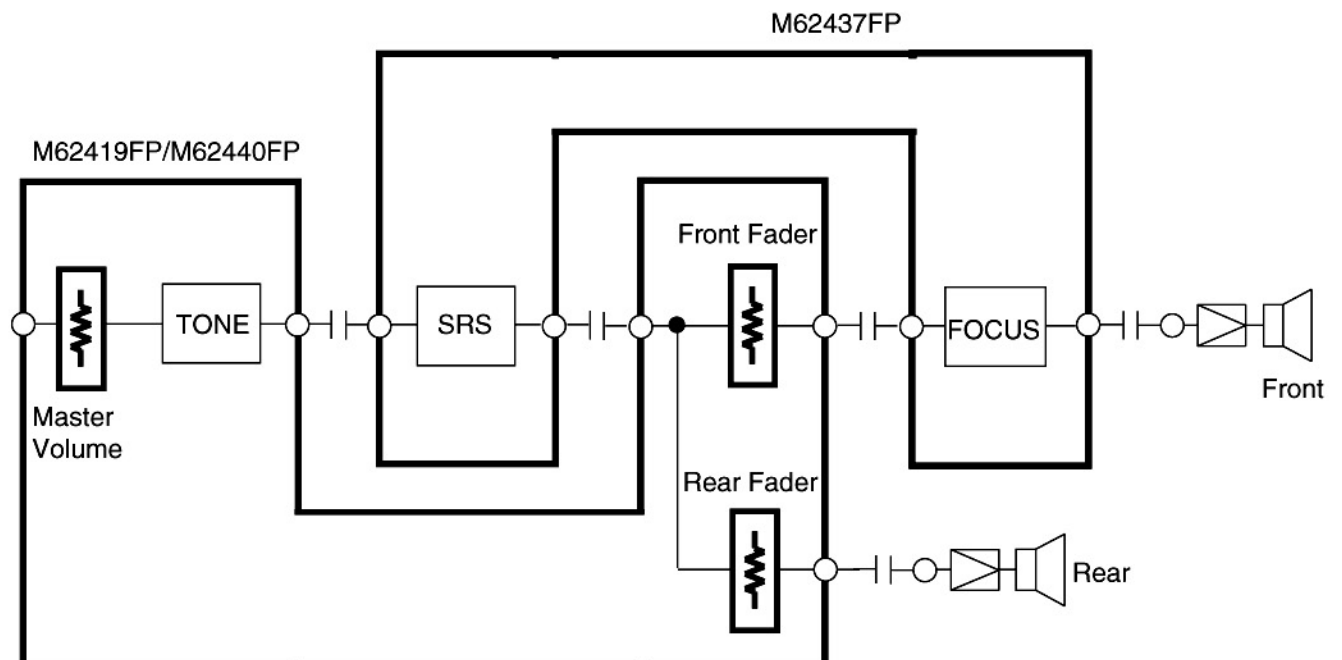

NOTE

Each switches (SRS ON/OFF, FOCUS ON/OFF and FOCUS Position H/L Switches) does not have the countermeasure for click noise, so that we recommend outside mute circuit.

SRS, the SRS logo, Sound Retrieval System and "everything else is only stereo" are registered trademarks of SRS Labs, Inc. This device available only to licensees of SRS Lab, Inc. Licensing and application information may be obtained from SRS Lab, Inc. Mitsubishi Electric Corporation assumes no responsibility for any damage, or infringement of any third-party's rights, originating in the use of any product data, diagrams, charts or circuit application examples contained in these materials.