

To all our customers

Regarding the change of names mentioned in the document, such as Hitachi Electric and Hitachi XX, to Renesas Technology Corp.

The semiconductor operations of Mitsubishi Electric and Hitachi were transferred to Renesas Technology Corporation on April 1st 2003. These operations include microcomputer, logic, analog and discrete devices, and memory chips other than DRAMs (flash memory, SRAMs etc.) Accordingly, although Hitachi, Hitachi, Ltd., Hitachi Semiconductors, and other Hitachi brand names are mentioned in the document, these names have in fact all been changed to Renesas Technology Corp. Thank you for your understanding. Except for our corporate trademark, logo and corporate statement, no changes whatsoever have been made to the contents of the document, and these changes do not constitute any alteration to the contents of the document itself.

Renesas Technology Home Page: <http://www.renesas.com>

Renesas Technology Corp.
Customer Support Dept.
April 1, 2003

Cautions

Keep safety first in your circuit designs!

1. Renesas Technology Corporation puts the maximum effort into making semiconductor products better and more reliable, but there is always the possibility that trouble may occur with them. Trouble with semiconductors may lead to personal injury, fire or property damage.
Remember to give due consideration to safety when making your circuit designs, with appropriate measures such as (i) placement of substitutive, auxiliary circuits, (ii) use of nonflammable material or (iii) prevention against any malfunction or mishap.

Notes regarding these materials

1. These materials are intended as a reference to assist our customers in the selection of the Renesas Technology Corporation product best suited to the customer's application; they do not convey any license under any intellectual property rights, or any other rights, belonging to Renesas Technology Corporation or a third party.
2. Renesas Technology Corporation assumes no responsibility for any damage, or infringement of any third-party's rights, originating in the use of any product data, diagrams, charts, programs, algorithms, or circuit application examples contained in these materials.
3. All information contained in these materials, including product data, diagrams, charts, programs and algorithms represents information on products at the time of publication of these materials, and are subject to change by Renesas Technology Corporation without notice due to product improvements or other reasons. It is therefore recommended that customers contact Renesas Technology Corporation or an authorized Renesas Technology Corporation product distributor for the latest product information before purchasing a product listed herein.
The information described here may contain technical inaccuracies or typographical errors.
Renesas Technology Corporation assumes no responsibility for any damage, liability, or other loss rising from these inaccuracies or errors.
Please also pay attention to information published by Renesas Technology Corporation by various means, including the Renesas Technology Corporation Semiconductor home page (<http://www.renesas.com>).
4. When using any or all of the information contained in these materials, including product data, diagrams, charts, programs, and algorithms, please be sure to evaluate all information as a total system before making a final decision on the applicability of the information and products. Renesas Technology Corporation assumes no responsibility for any damage, liability or other loss resulting from the information contained herein.
5. Renesas Technology Corporation semiconductors are not designed or manufactured for use in a device or system that is used under circumstances in which human life is potentially at stake. Please contact Renesas Technology Corporation or an authorized Renesas Technology Corporation product distributor when considering the use of a product contained herein for any specific purposes, such as apparatus or systems for transportation, vehicular, medical, aerospace, nuclear, or undersea repeater use.
6. The prior written approval of Renesas Technology Corporation is necessary to reprint or reproduce in whole or in part these materials.
7. If these products or technologies are subject to the Japanese export control restrictions, they must be exported under a license from the Japanese government and cannot be imported into a country other than the approved destination.
Any diversion or reexport contrary to the export control laws and regulations of Japan and/or the country of destination is prohibited.
8. Please contact Renesas Technology Corporation for further details on these materials or the products contained therein.

Hitachi SuperH™ RISC engine

SH7616

HD6417616

Hardware Manual

RENESAS

ADE-602-243

Rev. 1.0

3/5/03

Hitachi, Ltd.

Cautions

1. Hitachi neither warrants nor grants licenses of any rights of Hitachi's or any third party's patent, copyright, trademark, or other intellectual property rights for information contained in this document. Hitachi bears no responsibility for problems that may arise with third party's rights, including intellectual property rights, in connection with use of the information contained in this document.
2. Products and product specifications may be subject to change without notice. Confirm that you have received the latest product standards or specifications before final design, purchase or use.
3. Hitachi makes every attempt to ensure that its products are of high quality and reliability. However, contact Hitachi's sales office before using the product in an application that demands especially high quality and reliability or where its failure or malfunction may directly threaten human life or cause risk of bodily injury, such as aerospace, aeronautics, nuclear power, combustion control, transportation, traffic, safety equipment or medical equipment for life support.
4. Design your application so that the product is used within the ranges guaranteed by Hitachi particularly for maximum rating, operating supply voltage range, heat radiation characteristics, installation conditions and other characteristics. Hitachi bears no responsibility for failure or damage when used beyond the guaranteed ranges. Even within the guaranteed ranges, consider normally foreseeable failure rates or failure modes in semiconductor devices and employ systemic measures such as fail-safes, so that the equipment incorporating Hitachi product does not cause bodily injury, fire or other consequential damage due to operation of the Hitachi product.
5. This product is not designed to be radiation resistant.
6. No one is permitted to reproduce or duplicate, in any form, the whole or part of this document without written approval from Hitachi.
7. Contact Hitachi's sales office for any questions regarding this document or Hitachi semiconductor products.

Preface

The SH7616 is a microprocessor that integrates peripheral functions necessary for system configuration with a 32-bit internal architecture SH2-DSP CPU as its core.

The SH7616's on-chip peripheral functions include a cache memory, an interrupt controller, timers, an ethernet controller (EtherC), DSP, a serial communication interface with FIFO (SCIF), a USB function module, a user break controller (UBC), a bus state controller (BSC), a direct memory access controller (DMAC), and I/O ports, making it ideal for use as a microcomputer in electronic devices that require high speed together with low power consumption.

Intended Readership: This manual is intended for users undertaking the design of an application system using the SH7616. Readers using this manual require a basic knowledge of electrical circuits, logic circuits, and microcomputers.

Purpose: The purpose of this manual is to give users an understanding of the hardware functions and electrical characteristics of the SH7616. Details of execution instructions can be found in the SH-1, SH-2, SH-DSP Programming Manual, which should be read in conjunction with the present manual.

Using this Manual:

- For an overall understanding of the SH7616's functions
Follow the Table of Contents. This manual is broadly divided into sections on the CPU, system control functions, peripheral functions, and electrical characteristics.
- For a detailed understanding of CPU functions
Refer to the separate publication SH-1, SH-2, SH-DSP Programming Manual.
Note on bit notation: Bits are shown in high-to-low order from left to right.

Related Material: The latest information is available at our Web Site. Please make sure that you have the most up-to-date information available.
<http://www.hitachisemiconductor.com/>

User's Manuals on the SH7616:

Manual Title	ADE No.
SH7616 Hardware Manual	This manual
SH-1, SH-2, SH-DSP Programming Manual	ADE-602-085

Users manuals for development tools:

Manual Title	ADE No.
C/C++ Compiler, Assembler, Optimized Linkage Editor User's Manual	ADE-702-304
Simulator Debugger Users Manual	ADE-702-266
Hitachi Embedded Workshop Users Manual	ADE-702-275

Application Note:

Manual Title	ADE No.
C/C++ Compiler	ADE-502-046

Contents

Section 1	Overview	1
1.1	Features of SuperH Microcomputer with On-Chip Ethernet Controller	1
1.2	Block Diagram.....	13
1.3	Pin Description	14
1.3.1	Pin Arrangement	14
1.3.2	Pin Functions.....	15
1.3.3	Pin Multiplexing.....	21
1.4	Processing States	27
Section 2	CPU.....	31
2.1	Register Configuration	31
2.1.1	General Registers.....	31
2.1.2	Control Registers.....	33
2.1.3	System Registers	36
2.1.4	DSP Registers.....	37
2.1.5	Notes on Guard Bits and Overflow Treatment.....	40
2.1.6	Initial Values of Registers	40
2.2	Data Formats.....	41
2.2.1	Data Format in Registers.....	41
2.2.2	Data Formats in Memory.....	41
2.2.3	Immediate Data Format.....	42
2.2.4	DSP Type Data Formats.....	42
2.2.5	DSP Type Instructions and Data Formats	44
2.3	CPU Core Instruction Features.....	48
2.4	Instruction Formats.....	52
2.4.1	CPU Instruction Addressing Modes.....	52
2.4.2	DSP Data Addressing	56
2.4.3	Instruction Formats for CPU Instructions	62
2.4.4	Instruction Formats for DSP Instructions.....	66
2.5	Instruction Set.....	72
2.5.1	CPU Instruction Set.....	73
2.5.2	DSP Data Transfer Instruction Set	89
2.5.3	DSP Operation Instruction Set	93
2.5.4	Various Operation Instructions	96
2.6	Usage Notes	105
2.6.1	When not using DSP instructions.....	105
2.6.2	When executing a combination of double-precision multiplication or double-precision product-sum operation (CPU instruction) and DSP computing instruction.....	105

Section 3	Oscillator Circuits and Operating Modes	107
3.1	Overview.....	107
3.2	On-Chip Clock Pulse Generator and Operating Modes	107
3.2.1	Clock Pulse Generator.....	107
3.2.2	Clock Operating Mode Settings	109
3.2.3	Connecting a Crystal Resonator	112
3.2.4	External Clock Input	113
3.2.5	Operating Frequency Selection by Register	114
3.2.6	Clock Modes and Frequency Ranges	122
3.2.7	Notes on Board Design	123
3.3	Bus Width of the CS0 Area	124
Section 4	Exception Handling.....	125
4.1	Overview.....	125
4.1.1	Types of Exception Handling and Priority Order	125
4.1.2	Exception Handling Operations	127
4.1.3	Exception Vector Table.....	128
4.2	Resets.....	131
4.2.1	Types of Resets	131
4.2.2	Power-On Reset.....	131
4.2.3	Manual Reset.....	132
4.3	Address Errors	132
4.3.1	Sources of Address Errors.....	132
4.3.2	Address Error Exception Handling	134
4.4	Interrupts.....	135
4.4.1	Interrupt Sources	135
4.4.2	Interrupt Priority Levels	136
4.4.3	Interrupt Exception Handling	136
4.5	Exceptions Triggered by Instructions.....	137
4.5.1	Instruction-Triggered Exception Types.....	137
4.5.2	Trap Instructions	137
4.5.3	Illegal Slot Instructions	138
4.5.4	General Illegal Instructions	138
4.6	When Exception Sources Are Not Accepted.....	139
4.6.1	Immediately after a Delayed Branch Instruction.....	139
4.6.2	Immediately after an Interrupt-Disabled Instruction.....	139
4.6.3	Instructions in Repeat Loops.....	140
4.7	Stack Status after Exception Handling	141
4.8	Usage Notes	142
4.8.1	Value of Stack Pointer (SP).....	142
4.8.2	Value of Vector Base Register (VBR)	142
4.8.3	Address Errors Caused by Stacking of Address Error Exception Handling	142
4.8.4	Manual Reset during Register Access.....	142

Section 5	Interrupt Controller (INTC)	143
5.1	Overview	143
5.1.1	Features	143
5.1.2	Block Diagram	143
5.1.3	Pin Configuration	145
5.1.4	Register Configuration	145
5.2	Interrupt Sources	146
5.2.1	NMI Interrupt	147
5.2.2	User Break Interrupt	147
5.2.3	H-UDI Interrupt	147
5.2.4	IRL Interrupts	147
5.2.5	IRQ Interrupts	148
5.2.6	On-chip Peripheral Module Interrupts	152
5.2.7	Interrupt Exception Vectors and Priority Order	152
5.3	Register Descriptions	159
5.3.1	Interrupt Priority Level Setting Register A (IPRA)	159
5.3.2	Interrupt Priority Level Setting Register B (IPRB)	160
5.3.3	Interrupt Priority Level Setting Register C (IPRC)	161
5.3.4	Interrupt Priority Level Setting Register D (IPRD)	162
5.3.5	Interrupt Priority Level Setting Register E (IPRE)	163
5.3.6	Vector Number Setting Register WDT (VCRWDT)	164
5.3.7	Vector Number Setting Register A (VCRA)	165
5.3.8	Vector Number Setting Register B (VCRB)	166
5.3.9	Vector Number Setting Register C (VCRC)	166
5.3.10	Vector Number Setting Register D (VCRD)	167
5.3.11	Vector Number Setting Register E (VCRE)	168
5.3.12	Vector Number Setting Register F (VCRF)	169
5.3.13	Vector Number Setting Register G (VCRG)	170
5.3.14	Vector Number Setting Register H (VCRH)	171
5.3.15	Vector Number Setting Register I (VCRI)	172
5.3.16	Vector Number Setting Register J (VCRJ)	173
5.3.17	Vector Number Setting Register K (VCRK)	174
5.3.18	Vector Number Setting Register L (VCRL)	175
5.3.19	Vector Number Setting Register M (VCRM)	176
5.3.20	Vector Number Setting Register N (VCRN)	177
5.3.21	Vector Number Setting Register O (VCRO)	178
5.3.22	Vector Number Setting Register P (VCRP)	179
5.3.23	Vector Number Setting Register Q (VCRQ)	180
5.3.24	Vector Number Setting Register R (VCRR)	181
5.3.25	Vector Number Setting Register S (VCRS)	182
5.3.26	Vector Number Setting Register T (VCRT)	183
5.3.27	Vector Number Setting Register U (VCRU)	184
5.3.28	Interrupt Control Register (ICR)	187

5.3.29	IRQ Control/Status Register (IRQCSR)	188
5.4	Interrupt Operation	190
5.4.1	Interrupt Sequence.....	190
5.4.2	Stack State after Interrupt Exception Handling.....	192
5.5	Interrupt Response Time.....	192
5.6	Sampling of Pins $\overline{IRL3}$ – $\overline{IRL0}$	194
5.7	Usage Notes	195
Section 6 User Break Controller (UBC).....		199
6.1	Overview.....	199
6.1.1	Features	199
6.1.2	Block Diagram.....	200
6.1.3	Register Configuration	201
6.2	Register Descriptions.....	203
6.2.1	Break Address Register A (BARA)	203
6.2.2	Break Address Mask Register A (BAMRA).....	204
6.2.3	Break Bus Cycle Register A (BBRA).....	205
6.2.4	Break Address Register B (BARB).....	207
6.2.5	Break Address Mask Register B (BAMRB)	208
6.2.6	Break Bus Cycle Register B (BBRB)	209
6.2.7	Break Address Register C (BARC).....	211
6.2.8	Break Address Mask Register C (BAMRC)	212
6.2.9	Break Data Register C (BDRC)	214
6.2.10	Break Data Mask Register C (BDMRC).....	215
6.2.11	Break Bus Cycle Register C (BBRC)	217
6.2.12	Break Execution Times Register C (BETRC).....	218
6.2.13	Break Address Register D (BARD)	219
6.2.14	Break Address Mask Register D (BAMRD).....	220
6.2.15	Break Data Register D (BDRD).....	222
6.2.16	Break Data Mask Register D (BDMRD).....	223
6.2.17	Break Bus Cycle Register D (BBRD).....	225
6.2.18	Break Execution Times Register D (BETRD)	226
6.2.19	Break Control Register (BRCR)	227
6.2.20	Branch Flag Registers (BRFR)	233
6.2.21	Branch Source Registers (BRSR)	234
6.2.22	Branch Destination Registers (BRDR)	235
6.3	Operation	236
6.3.1	User Break Operation Sequence	236
6.3.2	Instruction Fetch Cycle Break.....	237
6.3.3	Data Access Cycle Break	238
6.3.4	Saved Program Counter (PC) Value	239
6.3.5	X Memory Bus or Y Memory Bus Cycle Break	239
6.3.6	Sequential Break	240

6.3.7	PC Traces.....	241
6.3.8	Examples of Use.....	243
6.3.9	Usage Notes.....	248
Section 7 Bus State Controller (BSC).....		251
7.1	Overview.....	251
7.1.1	Features	251
7.1.2	Block Diagram.....	253
7.1.3	Pin Configuration	254
7.1.4	Register Configuration	256
7.1.5	Address Map	257
7.2	Register Descriptions.....	259
7.2.1	Bus Control Register 1 (BCR1).....	259
7.2.2	Bus Control Register 2 (BCR2).....	262
7.2.3	Bus Control Register 3 (BCR3).....	263
7.2.4	Wait Control Register 1 (WCR1).....	265
7.2.5	Wait Control Register 2 (WCR2).....	267
7.2.6	Wait Control Register 3 (WCR3).....	269
7.2.7	Individual Memory Control Register (MCR).....	270
7.2.8	Refresh Timer Control/Status Register (RTCSR).....	274
7.2.9	Refresh Timer Counter (RTCNT).....	276
7.2.10	Refresh Time Constant Register (RTCOR).....	277
7.3	Access Size and Data Alignment	277
7.3.1	Connection to Ordinary Devices	277
7.3.2	Connection to Little-Endian Devices	279
7.4	Accessing Ordinary Space.....	280
7.4.1	Basic Timing	280
7.4.2	Wait State Control.....	285
7.4.3	\overline{CS} Assertion Period Extension	289
7.5	Synchronous DRAM Interface.....	290
7.5.1	Synchronous DRAM Direct Connection.....	290
7.5.2	Address Multiplexing	292
7.5.3	Burst Reads	294
7.5.4	Single Reads	299
7.5.5	Single Writes	301
7.5.6	Burst Write Mode.....	302
7.5.7	Bank Active Function.....	305
7.5.8	Refreshes	315
7.5.9	Overlap Between Auto Precharge Cycle (Tap) and Next Access	318
7.5.10	Power-On Sequence	319
7.5.11	64 Mbit Synchronous DRAM (2 Mword \times 32 Bit) Connection.....	321
7.6	DRAM Interface.....	322
7.6.1	DRAM Direct Connection.....	322

7.6.2	Address Multiplexing	323
7.6.3	Basic Timing	324
7.6.4	Wait State Control.....	325
7.6.5	Burst Access	327
7.6.6	EDO Mode.....	330
7.6.7	DRAM Single Transfer	334
7.6.8	Refreshing	335
7.6.9	Power-On Sequence	337
7.7	Burst ROM Interface	337
7.8	Idles between Cycles	341
7.9	Bus Arbitration	342
7.9.1	Master Mode	347
7.10	Additional Items	348
7.10.1	Resets.....	348
7.10.2	Access as Viewed from CPU, DMAC or E-DMAC	349
7.10.3	STATS1 and STATS0 Pins	350
7.10.4	$\overline{\text{BUSHiZ}}$ Specification.....	351
7.11	Usage Notes	351
7.11.1	Normal Space Access after Synchronous DRAM Write when Using DMAC	351
7.11.2	When Using If : Ef Clock Ratio of 1 : 1, 8-Bit Bus Width, and External Wait Input.....	354
7.11.3	When connecting external device to synchronous DRAM	354
Section 8 Cache		355
8.1	Introduction.....	355
8.1.1	Register Configuration	356
8.2	Register Description	356
8.2.1	Cache Control Register (CCR).....	356
8.3	Address Space and the Cache.....	358
8.4	Cache Operation	359
8.4.1	Cache Reads	359
8.4.2	Write Access	361
8.4.3	Cache-Through Access	364
8.4.4	The TAS Instruction	364
8.4.5	Pseudo-LRU and Cache Replacement.....	364
8.4.6	Cache Initialization	366
8.4.7	Associative Purges.....	366
8.4.8	Cache Flushing	367
8.4.9	Data Array Access.....	367
8.4.10	Address Array Access	368
8.5	Cache Use	369
8.5.1	Initialization.....	369
8.5.2	Purge of Specific Lines	370

8.5.3	Cache Data Coherency	370
8.5.4	Two-Way Cache Mode	371
8.6	Usage Notes	372
8.6.1	Standby	372
8.6.2	Cache Control Register	372
Section 9 Ethernet Controller (EtherC)		373
9.1	Overview.....	373
9.1.1	Features	373
9.1.2	Configuration.....	374
9.1.3	Pin Configuration	376
9.1.4	Ethernet Controller Register Configuration	377
9.2	Register Descriptions.....	378
9.2.1	EtherC Mode Register (ECMR)	378
9.2.2	EtherC Status Register (ECSR).....	381
9.2.3	EtherC Interrupt Permission Register (ECSIPR)	382
9.2.4	PHY Interface Register (PIR)	383
9.2.5	MAC Address High Register (MAHR).....	384
9.2.6	MAC Address Low Register (MALR)	385
9.2.7	Receive Frame Length Register (RFLR).....	386
9.2.8	PHY Interface Status Register (PSR)	387
9.2.9	Transmit Retry Over Counter Register (TROCR).....	388
9.2.10	Single Collision Detect Counter Register (SCDCR).....	389
9.2.11	Delay Collision Detect Counter Register (CDCR)	390
9.2.12	Lost Carrier Counter Register (LCCR)	391
9.2.13	Carrier Not Detect Counter Register (CNDCR)	392
9.2.14	Illegal Frame Length Counter Register (IFLCR)	393
9.2.15	CRC Error Frame Counter Register (CEFCR).....	394
9.2.16	Frame Receive Error Counter Register (FRECR)	395
9.2.17	Too-Short Frame Receive Counter Register (TSFRCR).....	396
9.2.18	Too-Long Frame Receive Counter Register (TLFRCR)	397
9.2.19	Residual-Bit Frame Counter Register (RFCR)	398
9.2.20	Multicast Address Frame Counter Register (MAFCR).....	399
9.3	Operation	400
9.3.1	Transmission	400
9.3.2	Reception.....	402
9.3.3	MII Frame Timing.....	404
9.3.4	Accessing MII Registers	406
9.3.5	Magic Packet Detection.....	409
9.3.6	CPU Operating Mode and Ethernet Controller Operation	410
9.3.7	CAM Match Signal Input Function.....	411
9.4	Connection to PHY-LSI	413

Section 10	Ethernet Controller Direct Memory Access Controller (E-DMAC).....	415
10.1	Overview.....	415
10.1.1	Features	415
10.1.2	Configuration.....	416
10.1.3	Descriptor Management System	417
10.1.4	Register Configuration	417
10.2	Register Descriptions.....	419
10.2.1	E-DMAC Mode Register (EDMR)	419
10.2.2	E-DMAC Transmit Request Register (EDTRR).....	420
10.2.3	E-DMAC Receive Request Register (EDRRR)	421
10.2.4	Transmit Descriptor List Address Register (TDLAR)	422
10.2.5	Receive Descriptor List Address Register (RDLAR)	423
10.2.6	EtherC/E-DMAC Status Register (EESR)	424
10.2.7	EtherC/E-DMAC Status Interrupt Permission Register (EESIPR).....	430
10.2.8	Transmit/Receive Status Copy Enable Register (TRSCER).....	435
10.2.9	Receive Missed-Frame Counter Register (RMFCR)	436
10.2.10	Transmit FIFO Threshold Register (TFTR).....	437
10.2.11	FIFO Depth Register (FDR).....	439
10.2.12	Receiver Control Register (RCR)	440
10.2.13	E-DMAC Operation Control Register (EDOCR)	441
10.2.14	Receiving-Buffer Write Address Register (RBWAR)	442
10.2.15	Receiving-Descriptor Fetch Address Register (RDFAR).....	443
10.2.16	Transmission-Buffer Read Address Register (TBRAR).....	444
10.2.17	Transmission-Descriptor Fetch Address Register (TDFAR)	445
10.3	Operation	446
10.3.1	Descriptor List and Data Buffers.....	446
10.3.2	Transmission	452
10.3.3	Reception.....	454
10.3.4	Multi-Buffer Frame Transmit/Receive Processing	456
Section 11	Direct Memory Access Controller (DMAC).....	459
11.1	Overview.....	459
11.1.1	Features	459
11.1.2	Block Diagram.....	461
11.1.3	Pin Configuration	462
11.1.4	Register Configuration.....	463
11.2	Register Descriptions.....	464
11.2.1	DMA Source Address Registers 0 and 1 (SAR0, SAR1)	464
11.2.2	DMA Destination Address Registers 0 and 1 (DAR0, DAR1).....	464
11.2.3	DMA Transfer Count Registers 0 and 1 (TCR0, TCR1).....	465
11.2.4	DMA Channel Control Registers 0 and 1 (CHCR0, CHCR1)	466
11.2.5	DMA Vector Number Registers 0 and 1 (VCRDMA0, VCRDMA1)	470

11.2.6	DMA Request/Response Selection Control Registers 0 and 1 (DRCR0, DRCR1).....	471
11.2.7	DMA Operation Register (DMAOR).....	473
11.3	Operation	475
11.3.1	DMA Transfer Flow	475
11.3.2	DMA Transfer Requests.....	477
11.3.3	Channel Priorities	481
11.3.4	DMA Transfer Types	484
11.3.5	Number of Bus Cycles.....	494
11.3.6	DMA Transfer Request Acknowledge Signal Output Timing.....	494
11.3.7	DREQn Pin Input Detection Timing.....	505
11.3.8	DMA Transfer End.....	511
11.3.9	$\overline{\text{BH}}$ Pin Output Timing	512
11.4	Usage Examples	513
11.4.1	Example of DMA Data Transfer Between SCIF and External Memory.....	513
11.5	Usage Notes	514
Section 12 16-Bit Free-Running Timer (FRT).....		517
12.1	Overview.....	517
12.1.1	Features	517
12.1.2	Block Diagram.....	518
12.1.3	Pin Configuration	519
12.1.4	Register Configuration	519
12.2	Register Descriptions.....	520
12.2.1	Free-Running Counter (FRC).....	520
12.2.2	Output Compare Registers A and B (OCRA and OCRB).....	520
12.2.3	Input Capture Register (FICR)	521
12.2.4	Timer Interrupt Enable Register (TIER)	521
12.2.5	Free-Running Timer Control/Status Register (FTCSR).....	522
12.2.6	Timer Control Register (TCR)	524
12.2.7	Timer Output Compare Control Register (TOCR)	525
12.3	CPU Interface	526
12.4	Operation	529
12.4.1	FRC Count Timing.....	529
12.4.2	Output Timing for Output Compare.....	530
12.4.3	FRC Clear Timing.....	530
12.4.4	Input Capture Input Timing.....	531
12.4.5	Input Capture Flag (ICF) Setting Timing.....	532
12.4.6	Output Compare Flag (OCFA, OCFB) Setting Timing	532
12.4.7	Timer Overflow Flag (OVF) Setting Timing	533
12.5	Interrupt Sources.....	534
12.6	Example of FRT Use	534
12.7	Usage Notes	535

12.7.1	Contention between FRC Write and Clear.....	535
12.7.2	Contention between FRC Write and Increment	535
12.7.3	Contention between OCR Write and Compare Match	536
12.7.4	Internal Clock Switching and Counter Operation	537
12.7.5	Timer Output (FTOA, FTOB).....	539
Section 13	Watchdog Timer (WDT).....	541
13.1	Overview.....	541
13.1.1	Features	541
13.1.2	Block Diagram.....	542
13.1.3	Pin Configuration	542
13.1.4	Register Configuration	543
13.2	Register Descriptions.....	543
13.2.1	Watchdog Timer Counter (WTCNT)	543
13.2.2	Watchdog Timer Control/Status Register (WTCSR)	544
13.2.3	Reset Control/Status Register (RSTCSR)	545
13.2.4	Notes on Register Access	546
13.3	Operation	548
13.3.1	Operation in Watchdog Timer Mode	548
13.3.2	Operation in Interval Timer Mode	550
13.3.3	Operation when Standby Mode is Cleared.....	550
13.3.4	Timing of Overflow Flag (OVF) Setting.....	551
13.3.5	Timing of Watchdog Timer Overflow Flag (WOVF) Setting.....	551
13.4	Usage Notes	552
13.4.1	Contention between WTCNT Write and Increment	552
13.4.2	Changing CKS2 to CKS0 Bit Values	552
13.4.3	Switching between Watchdog Timer Mode and Interval Timer Mode.....	552
13.4.4	System Reset with WDTOVF.....	553
13.4.5	Internal Reset in Watchdog Timer Mode	553
Section 14	Serial Communication Interface with FIFO (SCIF)	555
14.1	Overview.....	555
14.1.1	Features	555
14.1.2	Block Diagrams.....	557
14.1.3	Pin Configuration	558
14.1.4	Register Configuration	559
14.2	Register Descriptions.....	560
14.2.1	Receive Shift Register (SCRSR).....	560
14.2.2	Receive FIFO Data Register (SCFRDR).....	560
14.2.3	Transmit Shift Register (SCTSR)	561
14.2.4	Transmit FIFO Data Register (SCFTDR)	561
14.2.5	Serial Mode Register (SCSMR)	561
14.2.6	Serial Control Register (SCSCR).....	564

14.2.7	Serial Status 1 Register (SC1SSR).....	568
14.2.8	Serial Status 2 Register (SC2SSR).....	573
14.2.9	Bit Rate Register (SCBRR).....	575
14.2.10	FIFO Control Register (SCFCR).....	583
14.2.11	FIFO Data Count Register (SCFDR).....	585
14.2.12	FIFO Error Register (SCFER).....	586
14.2.13	IrDA Mode Register (SCIMR).....	586
14.3	Operation	588
14.3.1	Overview	588
14.3.2	Operation in Asynchronous Mode.....	590
14.3.3	Multiprocessor Communication Function.....	602
14.3.4	Operation in Synchronous Mode.....	610
14.3.5	Use of Transmit/Receive FIFO Buffers	620
14.3.6	Operation in IrDA Mode	623
14.4	SCIF Interrupt Sources and the DMAC	627
14.5	Usage Notes	628
Section 15 Serial I/O with FIFO (SIOF).....		633
15.1	Overview.....	633
15.1.1	Features	633
15.2	Register Configuration	635
15.2.1	Receive Shift Register (SIRSR)	635
15.2.2	Receive Data Register (SIRDOR).....	636
15.2.3	Transmit Shift Register (SITSR).....	636
15.2.4	Transmit Data Register (SITDR).....	637
15.2.5	Serial Control Register (SICTR).....	638
15.2.6	Serial Status Register (SISTR)	641
15.2.7	Receive Control Data Register (SIRCDOR).....	644
15.2.8	Transmit Control Data Register (SITCDOR).....	644
15.2.9	FIFO Control Register (SIFCR)	645
15.2.10	FIFO Data Count Register (SIFDR).....	649
15.3	Operation	650
15.3.1	Input when TRMD = 0 in SIFCR.....	650
15.3.2	Output when TRMD = 0 in SIFCR	653
15.3.3	Output when TRMD = 1 in SIFCR	657
15.4	SIOF Interrupt Sources and DMAC	659
Section 16 Serial I/O (SIO).....		661
16.1	Overview.....	661
16.1.1	Features	661
16.2	Register Configuration	664
16.2.1	Receive Shift Register (SIRSR)	665
16.2.2	Receive Data Register (SIRDOR).....	665

16.2.3	Transmit Shift Register (SITSR).....	666
16.2.4	Transmit Data Register (SITDR).....	666
16.2.5	Serial Control Register (SICTR).....	667
16.2.6	Serial Status Register (SISTR).....	669
16.3	Operation.....	671
16.3.1	Input.....	671
16.3.2	Output.....	672
16.4	SIO Interrupt Sources and DMAC.....	675
Section 17 16-Bit Timer Pulse Unit (TPU).....		677
17.1	Overview.....	677
17.1.1	Features.....	677
17.1.2	Block Diagram.....	680
17.1.3	Pin Configuration.....	681
17.1.4	Register Configuration.....	682
17.2	Register Descriptions.....	683
17.2.1	Timer Control Register (TCR).....	683
17.2.2	Timer Mode Register (TMDR).....	687
17.2.3	Timer I/O Control Register (TIOR).....	689
17.2.4	Timer Interrupt Enable Register (TIER).....	696
17.2.5	Timer Status Register (TSR).....	698
17.2.6	Timer Counter (TCNT).....	701
17.2.7	Timer General Register (TGR).....	702
17.2.8	Timer Start Register (TSTR).....	702
17.2.9	Timer Synchronous Register (TSYR).....	703
17.3	Interface to Bus Master.....	704
17.3.1	16-Bit Registers.....	704
17.3.2	8-Bit Registers.....	704
17.4	Operation.....	706
17.4.1	Overview.....	706
17.4.2	Basic Functions.....	707
17.4.3	Synchronous Operation.....	713
17.4.4	Buffer Operation.....	715
17.4.5	PWM Modes.....	719
17.4.6	Phase Counting Mode.....	724
17.5	Interrupts.....	729
17.5.1	Interrupt Sources and Priorities.....	729
17.5.2	DMAC Activation.....	730
17.6	Operation Timing.....	731
17.6.1	Input/Output Timing.....	731
17.6.2	Interrupt Signal Timing.....	735
17.7	Usage Notes.....	738
17.8	Usage Notes.....	748

17.8.1	Clearing Flags in TSR0 to TSR2.....	748
17.8.2	DMA Transfer by TPU0	748
Section 18 Hitachi User Debug Interface (H-UDI)		
18.1	Overview.....	749
18.1.1	Features	749
18.1.2	H-UDI Block Diagram	750
18.1.3	Pin Configuration	751
18.1.4	Register Configuration	751
18.2	External Signals	752
18.2.1	Test Clock (TCK).....	752
18.2.2	Test Mode Select (TMS).....	752
18.2.3	Test Data Input (TDI).....	752
18.2.4	Test Data Output (TDO)	752
18.2.5	Test Reset (TRST).....	753
18.3	Register Descriptions.....	753
18.3.1	Instruction Register (SDIR).....	753
18.3.2	Status Register (SDSR)	755
18.3.3	Data Register (SDDR).....	756
18.3.4	Bypass Register (SDBPR).....	756
18.3.5	Boundary scan register (SDBSR).....	756
18.3.6	ID code register (SDIDR)	768
18.4	Operation	769
18.4.1	TAP Controller	769
18.4.2	H-UDI Interrupt and Serial Transfer.....	770
18.4.3	H-UDI Reset.....	773
18.5	Boundary Scan.....	773
18.5.1	Supported Instructions.....	773
18.5.2	Notes on Use	774
18.6	Usage Notes	775
Section 19 Pin Function Controller (PFC).....		
19.1	Overview.....	779
19.2	Register Configuration	781
19.3	Register Descriptions.....	781
19.3.1	Port A Control Register (PACR).....	781
19.3.2	Port A I/O Register (PAIOR)	784
19.3.3	Port B Control Registers (PBCR, PBCR2)	785
19.3.4	Port B I/O Register (PBIOR).....	791
Section 20 I/O Ports		
20.1	Overview.....	793
20.2	Port A.....	793

20.2.1	Register Configuration	794
20.2.2	Port A Data Register (PADR)	794
20.3	Port B	795
20.3.1	Register Configuration	795
20.3.2	Port B Data Register (PBDR)	796
Section 21 Power-Down Modes		797
21.1	Overview	797
21.1.1	Power-Down Modes	797
21.1.2	Register	798
21.2	Register Descriptions	799
21.2.1	Standby Control Register 1 (SBYCR1)	799
21.2.2	Standby Control Register 2 (SBYCR2)	801
21.3	Sleep Mode	803
21.3.1	Transition to Sleep Mode	803
21.3.2	Canceling Sleep Mode	803
21.4	Standby Mode	803
21.4.1	Transition to Standby Mode	803
21.4.2	Canceling Standby Mode	805
21.4.3	Standby Mode Cancellation by NMI Interrupt	805
21.4.4	Clock Pause Function	806
21.4.5	Notes on Standby Mode	809
21.5	Module Standby Function	809
21.5.1	Transition to Module Standby Function	809
21.5.2	Clearing the Module Standby Function	809
Section 22 Electrical Characteristics		811
22.1	Absolute Maximum Ratings	811
22.2	DC Characteristics	812
22.3	AC Characteristics	814
22.3.1	Clock Timing	815
22.3.2	Control Signal Timing	819
22.3.3	Bus Timing	821
22.3.4	Direct Memory Access Controller Timing	859
22.3.5	Free-Running Timer Timing	860
22.3.6	Serial Communication Interface Timing	862
22.3.7	Watchdog Timer Timing	865
22.3.8	Serial I/O with FIFO / Serial I/O Timing	866
22.3.9	Hitachi User Debug Interface Timing	869
22.3.10	I/O Port Timing	870
22.3.11	Ethernet Controller Timing	872
22.3.12	STATS, $\overline{\text{BH}}$, and $\overline{\text{BUSHiZ}}$ Signal Timing	875
22.4	AC Characteristic Test Conditions	877

Appendix A On-Chip Peripheral Module Registers.....	879
A.1 Addresses.....	879
Appendix B Pin States.....	897
B.1 Pin States in Reset, Power-Down State, and Bus-Released State	897
Appendix C Product Lineup	901
Appendix D Package Dimensions.....	902

Section 1 Overview

1.1 Features of SuperH Microcomputer with On-Chip Ethernet Controller

The SH7616 is a CMOS single-chip microcontroller that integrates a high-speed CPU core using an original Hitachi architecture with supporting functions required for an Ethernet system.

The CPU has a RISC (Reduced Instruction Set Computer) type instruction set. The CPU basically operates at a rate of one instruction per cycle, offering a great improvement in instruction execution speed. In addition, the 32-bit internal architecture provides improved data processing power, and DSP functions have also been enhanced with the implementation of extended Harvard architecture DSP data bus functions. With this CPU, it has become possible to assemble low-cost, high-performance/high-functionality systems even for applications such as realtime control, which could not previously be handled by microcontrollers because of their high-speed processing requirements. The SH7616 also includes a maximum 4-kbyte cache, for greater CPU processing power when accessing external memory.

The SH7616 is equipped with a media access controller (MAC) conforming to the IEEE802.3u standard, and an Ethernet controller that includes a media independent interface (MII) standard unit, enabling 10/100 Mbps LAN connection. Supporting functions necessary for system configuration are also provided, including RAM, timers, a serial communication interface with FIFO (SCIF), interrupt controller (INTC), and I/O ports.

To improve the efficiency of frame transmission/reception, the processing power of the DMAC for the Ethernet controller is improved and the FIFO for the DMAC has 2 kbytes. A CAM match signal input function is provided for systems that require multiple MAC addresses. In serial I/O with three channels, one operates with the FIFO for better data processing power when connected to the codec.

Table 1.1 Features

Item	Specifications
CPU	<ul style="list-style-type: none">• Original Hitachi architecture• 32-bit internal architecture• General register machine<ul style="list-style-type: none">— Sixteen 32-bit general registers— Six 32-bit control registers (including 3 added for DSP use)— Ten 32-bit system registers• RISC (Reduced Instruction Set Computer) type instruction set<ul style="list-style-type: none">— Fixed 16-bit instruction length for improved code efficiency— Load-store architecture (basic operations are executed between registers)— Delayed branch instructions reduce pipeline disruption during branches— C-oriented instruction set• Instruction execution time: One instruction per cycle (16.0 ns/instruction at 62.5 MHz operation)• Address space: Architecture supports 4 Gbytes• On-chip multiplier: Multiply operations (32 bits × 32 bits → 64 bits) and multiply-and-accumulate operations (32 bits × 32 bits + 64 bits → 64 bits) executed in two to four cycles• Five-stage pipeline

Table 1.1 Features (cont)

Item	Specifications
DSP	<ul style="list-style-type: none">• DSP engine<ul style="list-style-type: none">— Multiplier— Arithmetic logic unit (ALU)— Shifter— DSP registers• Multiplier<ul style="list-style-type: none">— 16 bits × 16 bits → 32 bits— Single-cycle multiplier• DSP registers<ul style="list-style-type: none">— Two 40-bit data registers— Six 32-bit data registers— Modulo register (MOD, 32 bits) added to control registers— Repeat counter (RC) added to status register (SR)— Repeat start register (RS, 32 bits) and repeat end register (RE, 32 bits) added to control registers• DSP data bus<ul style="list-style-type: none">— Extended Harvard architecture— Simultaneous access to two data buses and one instruction bus• Parallel processing<ul style="list-style-type: none">— Maximum of four parallel processes— ALU operations, multiplication, and two loads or stores• Address processors<ul style="list-style-type: none">— Two address processors— Address operations to access two memories• DSP data addressing modes<ul style="list-style-type: none">— Increment and index— Each with or without modulo addressing• Repeat control: Zero-overhead repeat (loop) control• Instruction set<ul style="list-style-type: none">— 16-bit length (in case of load or store only)— 32-bit length (including ALU operations and multiplication)— Added SuperH microcontroller instructions for accessing DSP registers• Fifth and last pipeline stage is DSP stage

Table 1.1 Features (cont)

Item	Specifications
Cache	<ul style="list-style-type: none">• Mixed instruction/data type cache• Maximum of 4 kbytes• 4-way set-associative type• 16-byte line length• 64 cache tag entries• 16-byte write-back buffer• Selection of write-through or write-back mode for data writes• LRU replacement algorithm• Can also be used as 2-kbyte cache and 2-kbyte RAM (2-way cache mode)• Mixed instruction/data cache, instruction cache, or data cache mode can be set• 1-cycle reads, 2-cycle writes (in write-back mode)
Interrupt controller (INTC)	<ul style="list-style-type: none">• 16 priority levels can be set• On-chip supporting module interrupt vector numbers can be set• 41 internal interrupt sources• The E-DMAC interrupt (EINT) is input to the INTC as the OR of 22 EtherC and E-DMAC interrupt sources (max.). Thus, from the viewpoint of the INTC, there is one EtherC/E-DMAC interrupt source.• Five external interrupt pins (NMI, $\overline{\text{IRL0}}$ to $\overline{\text{IRL3}}$) 15 external interrupt sources (encoded input) can also be selected for pins $\overline{\text{IRL0}}$ to $\overline{\text{IRL3}}$ (IRL interrupts)• IRL interrupt vector number setting can also be selected (selection of auto vector or external vector)• Provision for IRQ interrupt setting (low-level, rising-edge, falling-edge, both-edge detection)

Table 1.1 Features (cont)

Item	Specifications
User break controller (UBC), 4 channels (A, B, C, D)	<ul style="list-style-type: none">• Interrupt generation based on independent or sequential conditions for channels A, B, C, D<ul style="list-style-type: none">— Three sequential setting patterns: A → B → C → D, B → C → D, C → D• Settable break conditions: Address, data (channels C and D only), bus master (CPU/DMAC), bus cycle (instruction fetch/data access), read/write, operand cycle (byte/word/longword)• User break interrupt generated on occurrence of break condition• Processing can be stopped before or after instruction execution in instruction fetch cycle• Break with specification of number of executions (channels C and D only) Settable number of executions: max. $2^{12} - 1$ (4095)• PC trace function Branch source/branch destination can be traced in branch instruction fetch (max. 8 addresses (4 pairs))

Table 1.1 Features (cont)

Item	Specifications
Bus state controller (BSC)	<ul style="list-style-type: none">• Address space divided into five areas (CS0 to CS4, max. linear 32 Mbytes each)<ul style="list-style-type: none">— Memory types such as DRAM, synchronous DRAM, burst ROM, can be specified for each area— Two synchronous DRAM spaces (CS2, CS3); CS3 also supports DRAM— Bus width (8, 16, 32 bits) can be selected for each area— Wait state insertion control for each area— Control signal output for each area— Endian can be set for CS2 and CS4• Cache<ul style="list-style-type: none">— Cache area/cache-through area selection by access address— Selection of write-through or write-back mode• Refresh functions<ul style="list-style-type: none">— $\overline{\text{CAS}}$-before-$\overline{\text{RAS}}$ refreshing (auto refreshing) or self-refreshing— Refresh interval settable by means of refresh counter and clock select setting— Concentrated refreshing according to refresh count setting (1, 2, 4, 6, 8)— Refresh request output possible (REFOUT)• Direct DRAM interface<ul style="list-style-type: none">— Multiplexed row address/column address output— Fast page mode burst transfer and continuous access when reading— EDO mode— TP cycle generation to secure $\overline{\text{RAS}}$ precharge time• Direct synchronous DRAM interface<ul style="list-style-type: none">— Multiplexed row address/column address output— Bank-active mode (valid for CS3 only)— Selection of burst read/single write mode or burst read/burst write mode• Bus arbitration ($\overline{\text{BRLS}}$, $\overline{\text{BGR}}$)• Refresh counter can be used as interval timer<ul style="list-style-type: none">— Interrupt request generated on compare match (CMI interrupt request signal)

Table 1.1 Features (cont)

Item	Specifications
Direct memory access controller (DMAC), 2 channels	<ul style="list-style-type: none">• 4-Gbyte address space, maximum 16M (16,777,216) transfers• Selection of 8-bit, 16-bit, 32-bit, or 16-byte transfer data length• Parallel execution of CPU instruction processing and DMA operation possible in case of cache hit• Selection of dual address or single address mode<ul style="list-style-type: none">— Single address (data transfer rate of one transfer unit in one bus cycle)— Dual address (data transfer rate of one transfer unit in two bus cycles)— When synchronous DRAM is connected, 16-byte continuous read → continuous write transfer is possible (dual)• When SDRAM is connected, clocked single-address transfer is possible at rates up to 31.25 MHz• Cycle stealing or burst transfer• Relative channel priorities can be set (fixed mode/round robin mode)• DMA transfer is possible for the following devices:<ul style="list-style-type: none">— External memory, on-chip memory, on-chip supporting modules (excluding DMAC, BSC, UBC, cache, E-DMAC, EtherC)• External requests, DMA transfer requests from on-chip supporting modules, auto requests• Interrupt request (DEIn) can be issued to CPU at end of data transfer• DACK used for DREQ sampling (however, there is always one overrun as there is one acceptance before first DACK)
On-chip RAM	<ul style="list-style-type: none">• 4-kbyte X-RAM• 4-kbyte Y-RAM
Ethernet controller direct memory access controller (E-DMAC), 2 channels	<ul style="list-style-type: none">• Transfer possible between EtherC and external memory/on-chip memory• 16-byte burst transfer possible• Single address transfer• Chain block transfer• 32-bit transfer data width• 4-Gbyte address space• Data transfer possible from across byte boundaries in transmission• Each transmit and receive FIFO includes 2 kbytes

Table 1.1 Features (cont)

Item	Specifications
Ethernet controller (EtherC)	<ul style="list-style-type: none">• MAC (Media Access Control) functions<ul style="list-style-type: none">— Data frame assembly/disassembly (IEEE802.3-compliant frames)— CSMA/CD link management (collision avoidance, processing in case of collision)— CRC processing— Supports full-duplex transmission/reception— Transmitting and receiving short and long packets• Compatible with MII (Media Independent Interface) standard<ul style="list-style-type: none">— Converts 8-bit stream data from MAC level to MII nibble stream (4 bits)— Station management (STA) functions— 18 TTL-level signals— Variable transfer rate: 10/100 Mbps• Magic Packet™* (with WOL (Wake On LAN) output)• CAM match signal input function
Serial communication interface with FIFO (SCIF), 2 channels	<ul style="list-style-type: none">• Asynchronous mode<ul style="list-style-type: none">— Data length: 7 or 8 bits— Stop bit length: 1 or 2— Parity: Even, odd, or none— Receive error detection: Parity errors, framing errors, overrun errors— Break detection• Synchronous mode<ul style="list-style-type: none">— One serial communication format (8-bit data length)— Receive error detection: Overrun errors• IrDA mode (conforming to IrDA 1.0)• Simultaneous transmission/reception (full-duplex) capability<ul style="list-style-type: none">— Half-duplex communication used for IrDA communication• Built-in dedicated baud rate generator allows selection of bit rate• Built-in 16-stage transmit and receive FIFOs enable high-speed, continuous communication• Internal or external (SCK) transmit/receive clock source

Note: * Magic Packet is a registered trademark of Advanced Micro Devices, Inc.

Table 1.1 Features (cont)

Item	Specifications
Serial communication interface with FIFO (SCIF), 2 channels	<ul style="list-style-type: none">• Four interrupt sources<ul style="list-style-type: none">— Transmit FIFO data empty— Break— Receive FIFO data full— Receive error• Built-in modem control functions ($\overline{\text{RTS}}$, $\overline{\text{CTS}}$)• Detection of transmit and receive FIFO register data quantity and number of receive FIFO register transmit data errors• Timeout error (DR) can be detected during reception
Serial I/O with FIFO (SIOF)	<ul style="list-style-type: none">• Full-duplex operation (independent transmit and receive registers, and independent transmit and receive clocks)• Transmit and receive FIFO for primary data/transmit and receive buffer for control data (enabling continuous transmission/reception)• Interval transfer mode and continuous transfer mode• Choice of 8- or 16-bit data length• Data transfer communication by means of polling or interrupts• Choice of MSB- or LSB-first transfer for data I/O
Serial I/O (SIO), 2 channels	<ul style="list-style-type: none">• Full-duplex operation (independent transmit and receive registers, and independent transmit and receive clocks)• Transmit/receive ports with double-buffer structure (enabling continuous transmission/reception)• Interval transfer mode and continuous transfer mode• Choice of 8- or 16-bit data length• Data transfer communication by means of polling or interrupts• MSB-first transfer between SIO and data I/O

Table 1.1 Features (cont)

Item	Specifications
Hitachi user debug interface (H-UDI)	<ul style="list-style-type: none"> • Conforms to IEEE1149.1 standard <ul style="list-style-type: none"> — Five test signals (TCK, TDI, TDO, TMS, $\overline{\text{TRST}}$) — TAP controller — Instruction register — Data register — Bypass register • Test mode that conforms to the IEEE1149.1 standard <ul style="list-style-type: none"> — Standard instructions: BYPASS, SAMPLE/PRELOAD, and EXTEST — Optional instructions: CLAMP, HIGHZ, and IDCODE • H-UDI interrupt <ul style="list-style-type: none"> — H-UDI interrupt request to INTC • Reset hold
Timer pulse unit (TPU), 3 channels	<ul style="list-style-type: none"> • Maximum 8-pulse input/output • Total of eight timer general registers (TGR) (four for channel 0, two each for channels 1 and 2) <ul style="list-style-type: none"> — Waveform output by compare match: Selection of 0, 1, or toggle output — Input capture function: Selection of rising-edge, falling-edge, or both-edge detection — Counter clear operation: Counter clearing possible by compare match or input capture — Synchronous operation: Multiple timer counters (TCNT) can be written to simultaneously; simultaneous clearing by compare match and input capture possible; simultaneous register input/output possible by counter synchronous operation — PWM mode: Any PWM output duty can be set; maximum 7-phase PWM output possible by combination with synchronous operation • Buffer operation settable for channel 0 <ul style="list-style-type: none"> — Input capture register double-buffering possible — Automatic rewriting of output compare register possible • Phase counting mode settable independently for channels 1 and 2 <ul style="list-style-type: none"> — Two-phase encoder pulse up/down-count possible • 13 interrupt sources <ul style="list-style-type: none"> — For channel 0, four compare match/input capture dual-function interrupts and one overflow interrupt can be requested independently — For channels 1 and 2, two compare match/input capture dual-function interrupts, one overflow interrupt, and one underflow interrupt can be requested independently

Table 1.1 Features (cont)

Item	Specifications
16-bit free-running timer (FRT), 1 channel	<ul style="list-style-type: none">• Choice of four counter input clocks<ul style="list-style-type: none">— Three internal clocks ($P\phi/8$, $P\phi/32$, $P\phi/128$)— External clock (enabling external event counting)• Two independent comparators (allowing generation of two waveform outputs)• Input capture (choice of rising edge or falling edge)• Counter clear specification<ul style="list-style-type: none">— Counter value can be cleared by compare match A• Four interrupt sources<ul style="list-style-type: none">— Two compare match sources (OCIA, OCIB)— One input capture source (ICI)— One overflow source (OVI)
Watchdog timer (WDT), 1 channel	<ul style="list-style-type: none">• Can be switched between watchdog timer mode and interval timer mode• Internal reset, external signal (\overline{WDTOVF}), or interrupt generated on count overflow• Used when standby mode is cleared or the clock frequency is changed, and in clock pause mode• Selection of eight counter input clocks
Clock pulse generator (CPG)	<ul style="list-style-type: none">• Built-in clock pulse generator• Selection of crystal or external clock as clock source• Built-in clock-multiplication PLL circuits• Built-in PLL circuit for phase synchronization between external clock and internal clock• CPU/DSP core clock ($I\phi$), peripheral module clock ($P\phi$), and external interface clock ($E\phi$) frequencies can be scaled independently

Table 1.1 Features (cont)

Item	Specifications
System controller (SYSC)	<ul style="list-style-type: none">• Selection of seven operating mode settings, three power-down modes• Operating modes<ul style="list-style-type: none">— Control the method of clock generation (PLL ON/OFF) and clock division ratio• Power-down mode<ul style="list-style-type: none">— Sleep mode: CPU functions halted— Standby mode: All functions halted— Module standby function: Operation of FRT, SCIF, DMAC, UBC, DSP, TPU, and SIO on-chip supporting modules is halted selectively
I/O ports	<ul style="list-style-type: none">• 29 input/output ports

1.2 Block Diagram

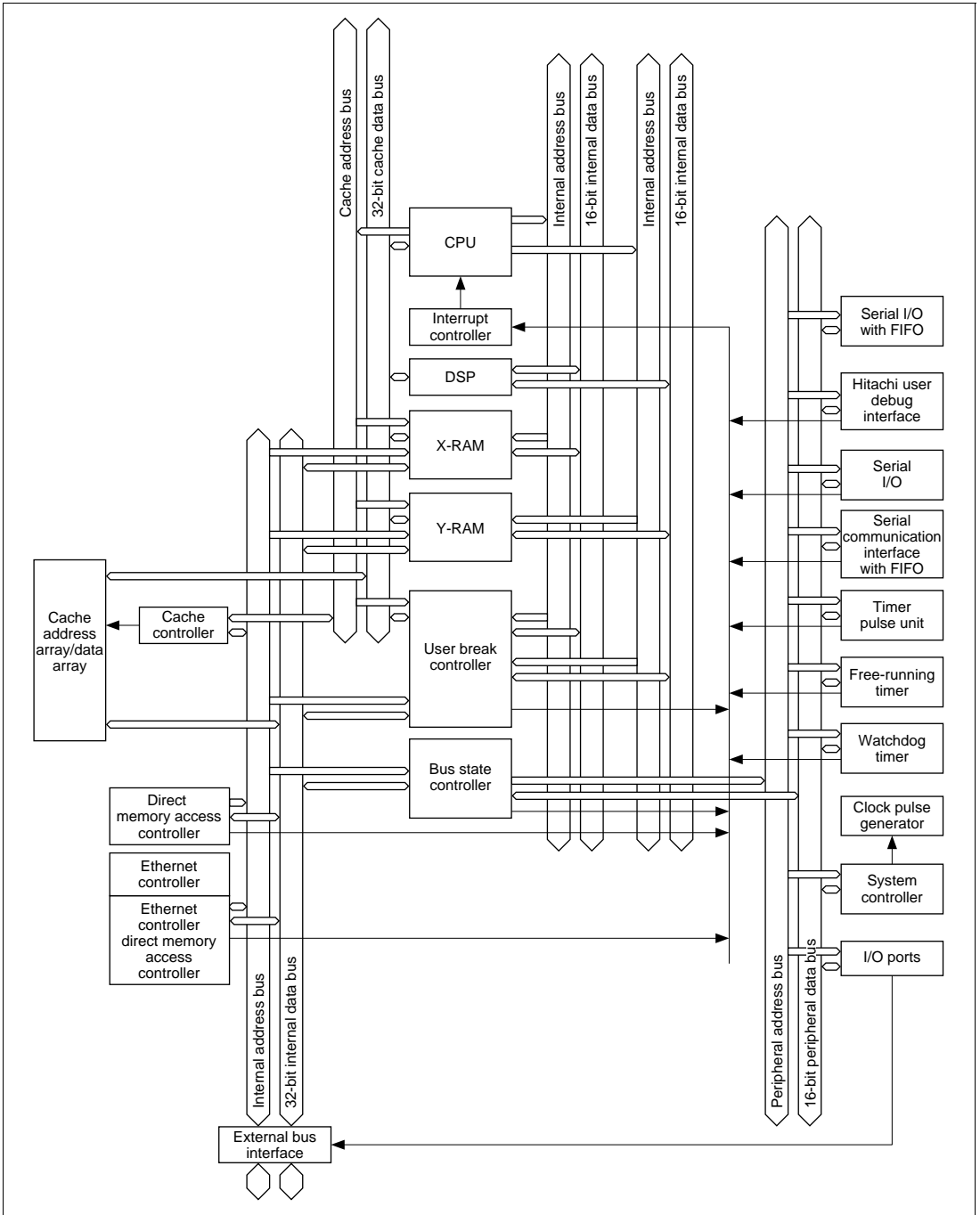

Figure 1.1 Block Diagram of SH7616

1.3 Pin Description

1.3.1 Pin Arrangement

Figure 1.2 shows the pin arrangement.

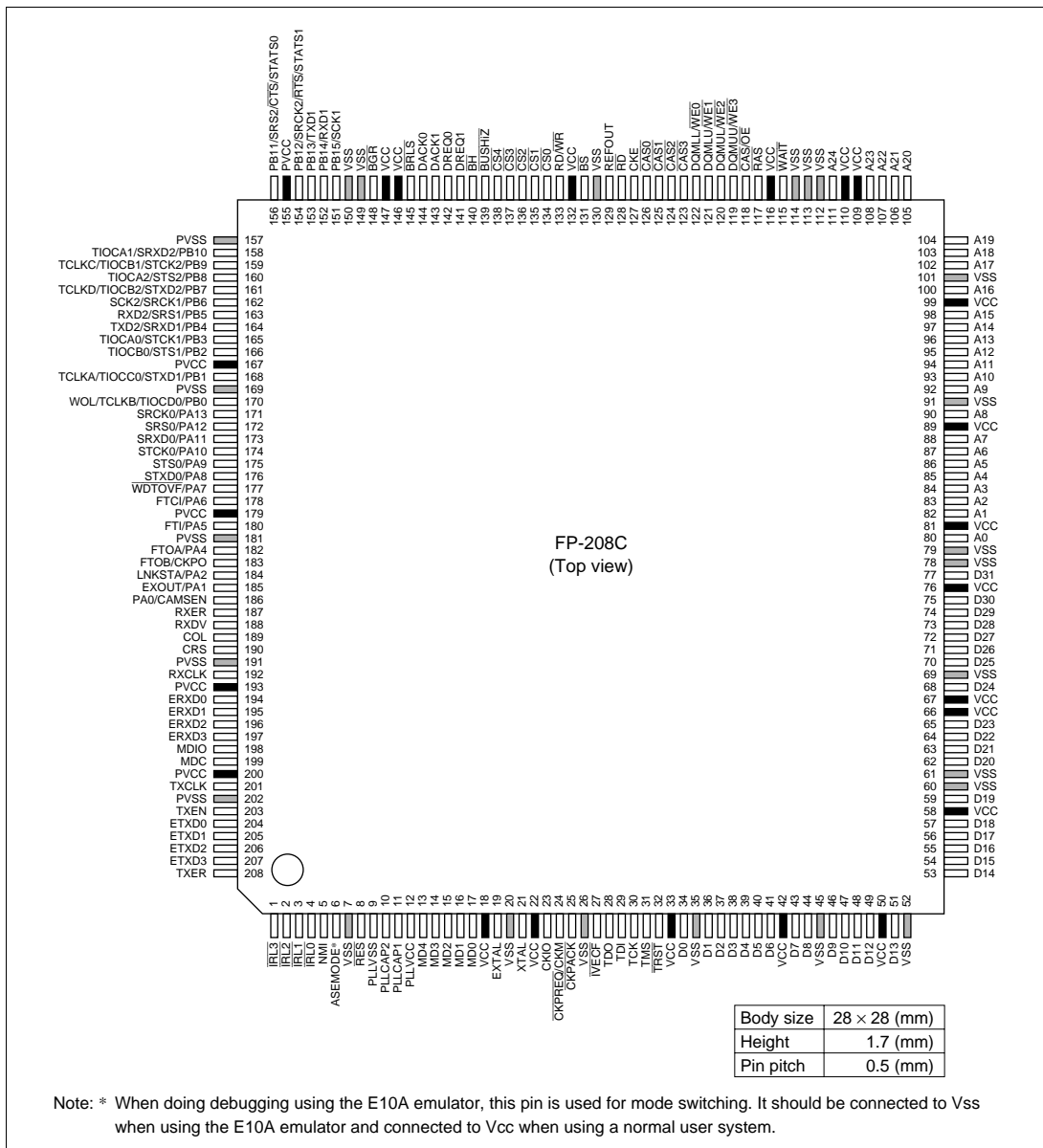

Figure 1.2 SH7616 Pin Arrangement (FP-208C)

1.3.2 Pin Functions

Table 1.2 Pin Functions

Type	Symbol	I/O	Name	Function
Power	V_{CC}	Input	Power	For connection to the power supply. Connect all V_{CC} pins to the system power supply. The chip will not operate if there are any open pins
	V_{SS}	Input	Ground	For connection to ground. Connect all V_{SS} pins to the system ground. The chip will not operate if there are any open pins
	PV_{CC}	Input	I/O circuit power	Power supply for the I/O circuits
	PV_{SS}	Input	I/O circuit ground	Ground for the I/O circuits
Clock	XTAL	Output	Crystal input/output pin	For connection to a crystal resonator
	EXTAL	Input		For connection to a crystal resonator, or used as external clock input pin
	CKIO	I/O	System clock input/output pin	Used as the external clock input or internal clock output pin
	\overline{CKPREQ}/CKM	Input	Clock pause request input	Used as the clock pause request pin for changing the frequency of the clock input from the CKIO pin, or halting the clock
	\overline{CKPACK}	Output	Clock pause acknowledge signal	Indicates that the chip is in the clock pause state (standby state) internally
	CKPO	Output	On-chip peripheral clock ($P\phi$) output	Outputs the on-chip peripheral clock ($P\phi$)
	PLLCAP1	Input	PLL capacitance connection pins	Connects capacitance for operation of PLL circuit 1
	PLLCAP2	Input		Connects capacitance for operation of PLL circuit 2
	$PLL_{V_{CC}}$	Input	PLL power	PLL oscillator power supply
$PLL_{V_{SS}}$	Input	PLL ground	PLL oscillator ground	

Table 1.2 Pin Functions (cont)

Type	Symbol	I/O	Name	Function
System control	$\overline{\text{RES}}$	Input	Reset	When $\overline{\text{RES}} = 0$ and $\text{NMI} = 1$, the chip enters the power-on reset state. When $\overline{\text{RES}} = 0$ and $\text{NMI} = 0$, the chip enters the manual reset state
	$\overline{\text{WDTOVF}}$	Output	Watchdog timer overflow	Counter overflow signal output in watchdog timer mode
	$\overline{\text{BGR}}$	Output	Bus grant	Indicates that the bus has been released to an external device. The device that output the $\overline{\text{BRLS}}$ signal recognizes that the bus has been acquired when it receives the $\overline{\text{BGR}}$ signal
	$\overline{\text{BRLS}}$	Input	Bus release	Driven low when an external device requests release of the bus
Operating mode	MD0–MD4	Input	Mode setting	The operating mode is specified by the levels at these pins
Interrupts	NMI	Input	Nonmaskable interrupt	Inputs the nonmaskable interrupt request signal
	$\overline{\text{IRL3}}\text{--}\overline{\text{IRL0}}$	Input	External interrupt request input 0 to 3	These pins input maskable interrupt request signals
	$\overline{\text{IVECF}}$	Output	Interrupt vector fetch cycle	Indicates an external vector read cycle
Bus control	$\overline{\text{BS}}$	Output	Bus cycle start	Signal indicating the start of a bus cycle Asserted every data cycle in burst transfer
	$\overline{\text{CS4}}\text{--}\overline{\text{CS0}}$	Output	Chip select 0 to 4	Chip select signals indicating the area being accessed
	$\overline{\text{WAIT}}$	Input	Wait	Wait state request signal
	$\overline{\text{RD}}$	Output	Read	Strobe signal indicating a read cycle
	$\overline{\text{RAS}}$	Output	Row address strobe	DRAM/synchronous DRAM RAS signal

Table 1.2 Pin Functions (cont)

Type	Symbol	I/O	Name	Function
Bus control	$\overline{\text{CAS}}$	Output	Column address strobe	Synchronous DRAM CAS signal
	$\overline{\text{OE}}$	Output	Output enable	EDO DRAM output enable signal Used in access in RAS down mode
	DQMUU/ $\overline{\text{WE3}}$	Output	Highest byte access	SRAM/synchronous DRAM highest byte select signal
	DQMUL/ $\overline{\text{WE2}}$	Output	Second byte access	SRAM/synchronous DRAM second byte select signal
	DQMLU/ $\overline{\text{WE1}}$	Output	Third byte access	SRAM/synchronous DRAM third byte select signal
	DQMLL/ $\overline{\text{WE0}}$	Output	Lowest byte access	SRAM/synchronous DRAM lowest byte select signal
	$\overline{\text{CAS3}}$	Output	Column address strobe 3	DRAM highest byte select signal
	$\overline{\text{CAS2}}$	Output	Column address strobe 2	DRAM second byte select signal
	$\overline{\text{CAS1}}$	Output	Column address strobe 1	DRAM third byte select signal
	$\overline{\text{CAS0}}$	Output	Column address strobe 0	DRAM lowest byte select signal
	CKE	Output	Clock enable	Synchronous DRAM clock enable signal
	REFOUT	Output	Refresh out	Signal requesting refresh execution when the bus is released
	$\overline{\text{RD/WR}}$	Output	Read/write	DRAM/synchronous DRAM write signal
	$\overline{\text{BUSHiZ}}$	Input	Bus high impedance	Signal used in combination with WAIT signal to place bus and strobe signals in the high-impedance state without the ending bus cycle
	$\overline{\text{BH}}$	Output	Burst hint	Asserted at the start of a DMA burst, negated one bus cycle before the end of the burst
STATS0, 1	Output	Status	CPU, DMAC, and E-DMAC status information	

Table 1.2 Pin Functions (cont)

Type	Symbol	I/O	Name	Function
Bus control	A24–A0	Output	Address bus	Address output
	D31–D0	I/O	Data bus	Data input/output
H-UDI	TCK	Input	Test clock	Test clock input
	TMS	Input	Test mode select	Test mode select input signal
	TDI	Input	Test data input	Serial data input
	TDO	Output	Test data output	Serial data output
	$\overline{\text{TRST}}$	Input	Test reset	Test reset input signal
	ASEMODE*	Input	ASE mode input	ASE mode/user mode select signal
Ethernet controller (EtherC)	TX-CLK	Input	Transmitter clock	TX-EN, ETXD0–3, TX-ER timing reference signal
	RX-CLK	Input	Receive clock	RX-DV, ERXD0–3, RX-ER timing reference signal
	TX-EN	Output	Transmit enable	Signal indicating that transmit data on ETXD0–3 is ready
	ETXD0–3	Output	Transmit data 0–3	4-bit receive data
	TX-ER	Output	Transmit error	Signal sending error status to another port
	RX-DV	Input	Receive data enable	Indicates that enable receive data on ERXD0–3 exist
	ERXD0–3	Input	Receive data 0–3	4-bit receive data
	RX-ER	Input	Receive error	Reports error state that occurred during transfer of frame data
	CRS	Input	Carrier sense	Carrier detection notification signal
	COL	Input	Collision	Collision detection signal
	MDC	Output	Management data clock	Reference clock signal for information transfer by MDIO
	MDIO	I/O	Management data input/output	Bidirectional signal for exchanging management information between STA and PHY

Note: * When carrying out debugging using the E10A emulator, this pin is used for mode switching. It should be connected to V_{SS} when using the E10A emulator and connected to V_{CC} when using a normal user system. When a boundary scan test is performed with the H-UDI, user mode must be used. A boundary scan test cannot be performed in ASE mode.

Table 1.2 Pin Functions (cont)

Type	Symbol	I/O	Name	Function
Ethernet controller (EtherC)	LNKSTA	Input	Link status	Link status input from PHY
	EXOUT	Output	General-purpose external output	General-purpose external output pin
	WOL	Output	Wake on LAN	Signal indicating detection of a Magic Packet
	CAMSEN	Input	CAM sense	CAM sense signal
Direct memory access controller (DMAC)	DACK0, 1	Output	DMAC channel 0, 1 acknowledge	These pins output receiving a DMA transfer request to an external device
	DREQ0, 1	Input	DMAC channel 0, 1 request	Pins that input DMA transfer requests from an external device
Serial communication interface with FIFO (SCIF)	TXD1, 2	Output	Transmit data output channel 1, 2	SCIF channel 1 and 2 transmit data output pins
	RXD1, 2	Input	Receive data output channel 1, 2	SCIF channel 1 and 2 receive data input pins
	SCK1, 2	I/O	Serial clock input/output channel 1, 2	SCIF clock input/output pins
	$\overline{\text{RTS}}$	Output	Transmit request	SCIF channel 1 transmit request output pin
	$\overline{\text{CTS}}$	Input	Transmit enable	SCIF channel 1 transmit enable input pin
Timer pulse unit (TPU)	TCLKA TCLKB TCLKC TCLKD	Input	TPU timer clock input A, B, C, D	Pins that input an external clock to the TPU counter
	TIOCA0 TIOCB0 TIOCC0 TIOCD0	I/O	TPU input capture/output compare (channel 0)	Channel 0 input capture input/output compare output/PWM output pins
	TIOCA1 TIOCB1	I/O	TPU input capture/output compare (channel 1)	Channel 1 input capture input/output compare output/PWM output pins

Table 1.2 Pin Functions (cont)

Type	Symbol	I/O	Name	Function
Timer pulse unit (TPU)	TIOCA2 TIOCB2	I/O	TPU input capture/output compare (channel 2)	Channel 2 input capture input/output compare output/PWM output pins
16-bit free-running timer (FRT)	FTCI	Input	Counter clock input	FRC counter clock input pin
	FTOA	Output	Output compare A output	Output compare A output pin
	FTOB	Output	Output compare B output	Output compare B output pin
	FTI	Input	Input capture input	Input capture input pin
Serial I/O with FIFO (SIOF)	SRXD0	Input	Serial receive data input 0	Serial receive data input ports
	SRCK0	Input	Serial receive clock input 0	Serial receive clock ports
	SRS0	Input	Serial receive synchronization clock input 0	Serial receive synchronization input ports
	STXD0	Output	Serial transmit data output 0	Serial data output ports
	STCK0	Input	Serial transmit clock input 0	Serial transmit clock ports
	STS0	I/O	Serial transmit synchronization clock input/output 0	Serial transmit synchronization input/output ports
Serial I/O (SIO)	SRXD1, 2	Input	Serial receive data input 1, 2	Serial receive data input ports
	SRCK1, 2	Input	Serial receive clock input 1, 2	Serial receive clock ports
	SRS1, 2	Input	Serial receive synchronization input 1, 2	Serial receive synchronization input ports
	STXD1, 2	Output	Serial transmit data output 1, 2	Serial data output ports
	STCK1, 2	Input	Serial transmit clock input 1, 2	Serial transmit clock ports
	STS1, 2	I/O	Serial transmit synchronization input/output 1, 2	Serial transmit synchronization input/output ports

Table 1.2 Pin Functions (cont)

Type	Symbol	I/O	Name	Function
I/O ports	PA0–PA13*	I/O	General port	General input/output port pins Input or output can be specified bit by bit
	PB0–PB15	I/O	General port	General input/output port pins Input or output can be specified bit by bit

Note: * PA3 cannot be used; CKPO is valid instead.

1.3.3 Pin Multiplexing

Table 1.3 Pin Multiplexing

No.	Function 1	Function 2	Function 3	Function 4	Type
12	PLL _{V_{CC}}				Clocks
9	PLL _{V_{SS}}				
11	PLLCAP1				
10	PLLCAP2				
19	EXTAL				
21	XTAL				
23	CKIO				
24	$\overline{\text{CKPREQ}}/\text{CKM}$				
25	$\overline{\text{CKPACK}}$				
8	$\overline{\text{RES}}$				System control
13	MD4				
14	MD3				
15	MD2				
16	MD1				
17	MD0				
5	NMI				Interrupts
1	$\overline{\text{IRL3}}$				
2	$\overline{\text{IRL2}}$				
3	$\overline{\text{IRL1}}$				
4	$\overline{\text{IRL0}}$				
27	$\overline{\text{IVECF}}$				6 pins

Table 1.3 Pin Multiplexing (cont)

No.	Function 1	Function 2	Function 3	Function 4	Type
131	\overline{BS}				Bus control
138	$\overline{CS4}$				
137	$\overline{CS3}$				
136	$\overline{CS2}$				
135	$\overline{CS1}$				
134	$\overline{CS0}$				
148	\overline{BGR}				
145	\overline{BRLS}				
115	\overline{WAIT}				
128	\overline{RD}				
117	\overline{RAS}				
118	$\overline{CAS/OE}$				
119	$\overline{DQMUU/WE3}$				
120	$\overline{DQMUL/WE2}$				
121	$\overline{DQMLU/WE1}$				
122	$\overline{DQMLL/WE0}$				
123	$\overline{CAS3}$				
124	$\overline{CAS2}$				
125	$\overline{CAS1}$				
126	$\overline{CAS0}$				
127	CKE				
129	REFOUT				
133	$\overline{RD/WR}$				
139	\overline{BUSHiZ}				
140	\overline{BH}				25 pins

Table 1.3 Pin Multiplexing (cont)

No.	Function 1	Function 2	Function 3	Function 4	Type
111	A24				Address bus
108	A23				
107	A22				
106	A21				
105	A20				
104	A19				
103	A18				
102	A17				
100	A16				
98	A15				
97	A14				
96	A13				
95	A12				
94	A11				
93	A10				
92	A9				
90	A8				
88	A7				
87	A6				
86	A5				
85	A4				
84	A3				
83	A2				
82	A1				
80	A0				25 pins

Table 1.3 Pin Multiplexing (cont)

No.	Function 1	Function 2	Function 3	Function 4	Type
77	D31				Data bus
75	D30				
74	D29				
73	D28				
72	D27				
71	D26				
70	D25				
68	D24				
65	D23				
64	D22				
63	D21				
62	D20				
59	D19				
57	D18				
56	D17				
55	D16				
54	D15				
53	D14				
51	D13				
49	D12				
48	D11				
47	D10				
46	D9				
44	D8				
43	D7				
41	D6				
40	D5				
39	D4				
38	D3				
37	D2				
36	D1				
34	D0				32 pins

Table 1.3 Pin Multiplexing (cont)

No.	Function 1	Function 2	Function 3	Function 4	Type
30	TCK				H-UDI
31	TMS				
29	TDI				
28	TDO				
32	$\overline{\text{TRST}}$				
6	ASEMODE*				
201	TX-CLK				EtherC
192	RX-CLK				
203	TX-EN				5 V I/O compatibility
207	ETXD3				
206	ETXD2				
205	ETXD1				
204	ETXD0				
208	TX-ER				
188	RX-DV				
197	ERXD3				
196	ERXD2				
195	ERXD1				
194	ERXD0				
187	RX-ER				
190	CRS				
189	COL				
199	MDC				
198	MDIO				18 pins
143	DACK1				DMAC
144	DACK0				
141	DREQ1				
142	DREQ0				4 pins

Note: * When carrying out debugging using the E10A emulator, this pin is used for mode switching. It should be connected to V_{SS} when using the E10A emulator (ASE mode). When using the chip in the normal user system, and not using the E10A emulator (user mode), connect this pin to V_{CC} . When a boundary scan test is performed with the H-UDI, user mode must be used. A boundary scan test cannot be performed in ASE mode.

Table 1.3 Pin Multiplexing (cont)

No.	Function 1 [00]*	Function 2 [01]*	Function 3 [10]*	Function 4 [11]*	Type
151	PB15		SCK1		Port B
152	PB14		RXD1		SCIF, SIO, TPU
153	PB13		TXD1		
154	PB12	SRCK2	$\overline{\text{RTS}}$	STATS1	5 V I/O compatibility
156	PB11	SRS2	$\overline{\text{CTS}}$	STATS0	
158	PB10	SRXD2	TIOCA1		
159	PB9	STCK2	TIOCB1/TCLKC		
160	PB8	STS2	TIOCA2		
161	PB7	STXD2	TIOCB2/TCLKD		
162	PB6	SRCK1	SCK2		
163	PB5	SRS1	RXD2		
164	PB4	SRXD1	TXD2		
165	PB3	STCK1	TIOCA0		
166	PB2	STS1	TIOCB0		
168	PB1	STXD1	TIOCC0/TCLKA		
170	PB0		TIOCD0/TCLKB	WOL	16 pins
171	PA13	SRCK0			Port A
172	PA12	SRS0			SIOF, FRT, WDT,
173	PA11	SRXD0			EtherC
174	PA10	STCK0			5 V I/O compatibility
175	PA9	STS0			
176	PA8	STXD0			
177	$\overline{\text{WDTOVF}}$	PA7			
178	PA6	FTCI			
180	PA5	FTI			
182	PA4	FTOA			
183	CKPO	FTOB			
184	PA2	LNKSTA			
185	PA1	EXOUT			
186	PA0	CAMSEN			14 pins

Note: * Figures in square brackets indicate the settings of the mode bits (MD0, MD1) in the PFC in order to select the multiplex functions in port A [0:13] and port B [0:15].

WDT0VF: In a reset, this pin becomes an output pin.
 When used for general input/output, attention must be paid to the polarity of this pin.

1.4 Processing States

State Transitions: The CPU has five processing states: the reset state, exception handling state, bus-released state, program execution state, and power-down state. Figure 1.3 shows the state transitions.

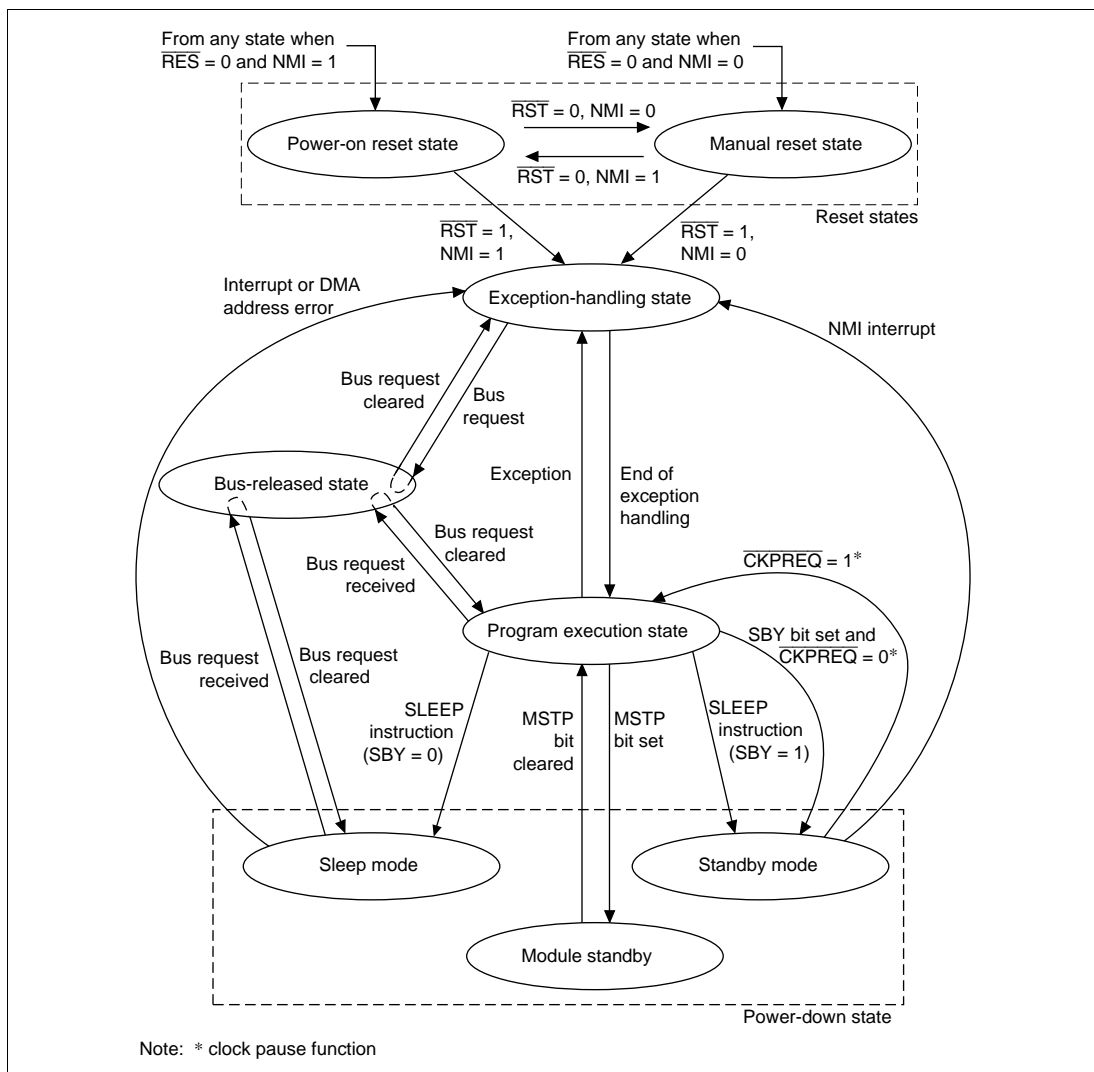

Figure 1.3 Processing State Transitions

Reset State: In this state, the CPU is reset. The reset state is entered when the $\overline{\text{RES}}$ pin goes low. The power-on reset state is entered if the NMI pin is high, and the manual reset state is entered if the NMI pin is low.

Exception Handling State: The exception handling state is a transient state that occurs when the CPU alters the normal programming flow due to a reset, interrupt, or other exception handling source.

In the case of a reset, the CPU fetches the execution start address as the initial value of the program counter (PC) from the exception vector table, and the initial value of the stack pointer (SP), stores these values, branches to the start address, and begins program execution at that address.

In the case of an interrupt, etc., the CPU references the SP and saves the PC and status register (SR) in the stack area. It fetches the start address of the exception service routine from the exception vector table, branches to that address, and begins program execution.

Subsequently, the processing state is the program execution state.

Program Execution State: In the program execution state the CPU executes program instructions in normal sequence.

Power-Down State: In the power-down state the CPU stops operating to conserve power. The power-down state is entered by executing a SLEEP instruction. The power-down state includes two modes—sleep mode and standby mode—and a module standby function.

Bus-Released State: In the bus-released state, the CPU releases the bus to a device that has requested it.

Power-Down State: In addition to the normal program execution state, another CPU processing state called the power-down state is provided. In this state, CPU operation is halted and power consumption is reduced. The power-down state includes two modes—sleep mode and standby mode—and a module standby function.

- Sleep Mode

A transition to sleep mode is made if the SLEEP instruction is executed while the standby bit (SBY) is cleared to 0 in standby control register 1 (SBYCR1). In sleep mode CPU operations stop but data in the CPU's internal registers and in on-chip cache memory and on-chip RAM is retained. The functions of the on-chip supporting modules do not stop.

- Standby Mode

A transition to standby mode is made if the SLEEP instruction is executed while SBY is set to 1 in SBYCR1. In standby mode the CPU, the on-chip modules, and the oscillator all stop.

When entering standby mode, the DMAC's DMA master enable bit should be cleared to 0.

Also, the cache should be turned off before entering this mode. The contents of the cache and on-chip RAM are not retained in this mode.

Standby mode is exited by means of a reset or an external NMI interrupt. When standby mode is exited, the normal program execution state is entered via the exception handling state after the elapse of the oscillation settling time.

If a transition is made to standby mode using the clock pause function, it is possible to change the frequency of the CKIO pin input clock, or to stop the clock itself. When SBY in SBYCR1 is set to 1 and a low level is applied to the $\overline{\text{CKPREQ}}/\text{CKM}$ pin, a transition is made to standby mode and a low level is output from the $\overline{\text{CKPACK}}$ pin. The clock can then be stopped, or its frequency changed.

On-chip supporting module states and pin states are the same as in the normal standby mode entered by means of the SLEEP instruction. A transition to the program execution state is made by applying a high level to the $\overline{\text{CKPREQ}}/\text{CKM}$ pin.

In this mode the oscillator is halted, greatly reducing power consumption.

- Module Standby Function

A module standby function is provided for the following on-chip supporting modules: the direct memory access controller (DMAC), DSP, 16-bit free-running timer (FRT), serial communication interface with FIFO (SCIF), serial I/O with FIFO (SIOF), serial I/O (SIO), user break controller (UBC), and timer pulse unit (TPU). A module standby function is not supported for the Ethernet controller (EtherC) or the Ethernet direct memory access controller (E-DMAC).

Setting one of module stop bits 11 to 3 and 1 (MSTP11 to MSTP3, MSTP1) to 1 in the standby control register (SBYCR1/2) stops the clock supply to the corresponding on-chip supporting module. Use of this function enables power consumption to be reduced.

The module standby function is cleared by clearing the corresponding MSTP bit to 0.

DSP instructions must not be used when the DSP has been placed in the module standby state.

When using the DMAC module standby function, the direct memory access controller's DMA master enable bit should be cleared to 0.

Table 1.4 Power-Down State

Mode	Entering Conditions	State					Exiting Conditions
		Clock	CPU	On-chip Supporting Modules	CPU Registers	On-Chip Cache or On-Chip RAM	
Sleep mode	Executing SLEEP instruction while SBY bit is cleared in SBYCR1	Operating	Halted	Operating	Held	Held	<ol style="list-style-type: none"> 1. Interrupt 2. DMA address error 3. Power-on reset 4. Manual reset
Standby mode	Executing SLEEP instruction while SBY bit is set in SBYCR1	Halted	Halted	Halted and initialized* ¹	Held	Undefined	<ol style="list-style-type: none"> 1. NMI interrupt 2. Power-on reset 3. Manual reset
Module standby function	Setting MSTP bit corresponding to individual module	Operating	Operating (DSP halted)	Clock supply to specified module halted, module initialized* ²	Held	Held	<ol style="list-style-type: none"> 1. Clearing MSTP bit 2. Power-on reset 3. Manual reset

Notes: *1 Depends on individual supporting module or pin.

*2 DMAC and DSP registers and specified module interrupt vectors retain their set values.

Section 2 CPU

2.1 Register Configuration

The register set consists of sixteen 32-bit general registers, six 32-bit control registers and ten 32-bit system registers.

This chip is upwardly compatible with the SH-1, SH-2 on the object code level. For this reason, several registers have been added to the previous SuperH microcontroller registers. The added registers are the three control registers: repeat start register (RS), repeat end register (RE), and modulo register (MOD) and the six system registers: DSP status register (DSR), and A0, A1, X0, X1, Y0 and Y1 among the DSP data registers.

The general registers are used in the same manner as the SH-1, SH-2 with regard to SuperH microcontroller-type instructions. With regard to DSP type instructions, they are used as address and index registers for accessing memory.

2.1.1 General Registers

There are 16 general registers (R_n) numbered R0–R15, which are 32 bits in length. General registers are used for data processing and address calculation.

With SuperH microcomputer type instructions, R0 is also used as an index register. Several instructions are limited to use of R0 only. R15 is used as the hardware stack pointer (SP). Saving and recovering the status register (SR) and program counter (PC) in exception processing is accomplished by referencing the stack using R15.

With DSP type instructions, eight of the 16 general registers are used for the addressing of X, Y data memory and data memory (single data) using the I bus.

R4, R5 are used as an X address register (A_x) for X memory accesses, and R8 is used as an X index register (I_x). R6, R7 are used as a Y address register (A_y) for Y memory accesses, and R9 is used as a Y index register (I_y). R2, R3, R4, R5 are used as a single data address register (A_s) for accessing single data using the I bus, and R8 is used as a single data index register (I_s).

DSP type instructions can simultaneously access X and Y data memory. There are two groups of address pointers for designating X and Y data memory addresses.

Figure 2.1 shows the general registers.

31	0
R0* ¹	
R1	
R2, [As]* ³	
R3, [As]* ³	
R4, [As, Ax]* ³	
R5, [As, Ax]* ³	
R6, [Ay]* ³	
R7, [Ay]* ³	
R8, [Ix, Is]* ³	
R9, [Iy]* ³	
R10	
R11	
R12	
R13	
R14	
R15, SP * ²	

- Notes:
- *1 R0 also functions as an index register in the indirect indexed register addressing mode and indirect indexed GBR addressing mode. In some instructions, only the R0 functions as a source register or destination register.
 - *2 R15 functions as a hardware stack pointer (SP) during exception processing.
 - *3 Used as memory address registers, memory index registers with DSP type instructions.

Figure 2.1 General Register Configuration

With the assembler, symbol names are used for R2, R3 ... R9. If it is wished to use a name that makes clear the role of a register for DSP type instructions, a different register name (alias) can be used. This is written in the following manner for the assembler.

```
Ix:      .REG (R8)
```

The name Ix is an alias for R8. The other aliases are assigned as follows:

Ax0:	.REG (R4)	
Ax1:	.REG (R5)	
Ix:	.REG (R8)	
Ay0:	.REG (R6)	
Ay1:	.REG (R7)	
Iy:	.REG (R9)	
As0:	.REG (R4)	defined when an alias is required for single data transfer
As1:	.REG (R5)	defined when an alias is required for single data transfer
As2:	.REG (R2)	defined when an alias is required for single data transfer
As3:	.REG (R3)	defined when an alias is required for single data transfer
Is:	.REG (R8)	defined when an alias is required for single data transfer

2.1.2 Control Registers

The six 32-bit control registers consist of the status register (SR), repeat start register (RS), repeat end register (RE), global base register (GBR), vector base register (VBR), and modulo register (MOD).

The SR register indicates processing states.

The GBR register functions as a base address for the indirect GBR addressing mode, and is used for such as on-chip peripheral module register data transfers.

The VBR register functions as the base address of the exception processing vector area (including interrupts).

The RS and RE registers are used for program repeat (loop) control. The repeat count is designated in the SR register repeat counter (RC), the repeat start address in the RS register, and the repeat end address in the RE register. However, note that the address values stored in the RS and RE registers are not necessarily always the same as the physical start and end address values of the repeat.

The MOD register is used for modulo addressing to buffer the repeat data. The modulo addressing designation is made by DMX or DMY, the modulo end address (ME) is designated in the upper 16 bits of the MOD register, and the modulo start address (MS) is designated in the lower 16 bits. Note that the DMX and DMY bits cannot simultaneously designate modulo addressing. Modulo addressing is possible with X and Y data transfer instructions (MOVX, MOVY). It is not possible with single data transfer instructions (MOVS).

Figure 2.2 shows the control registers. Table 2.1 indicates the SR register bits.

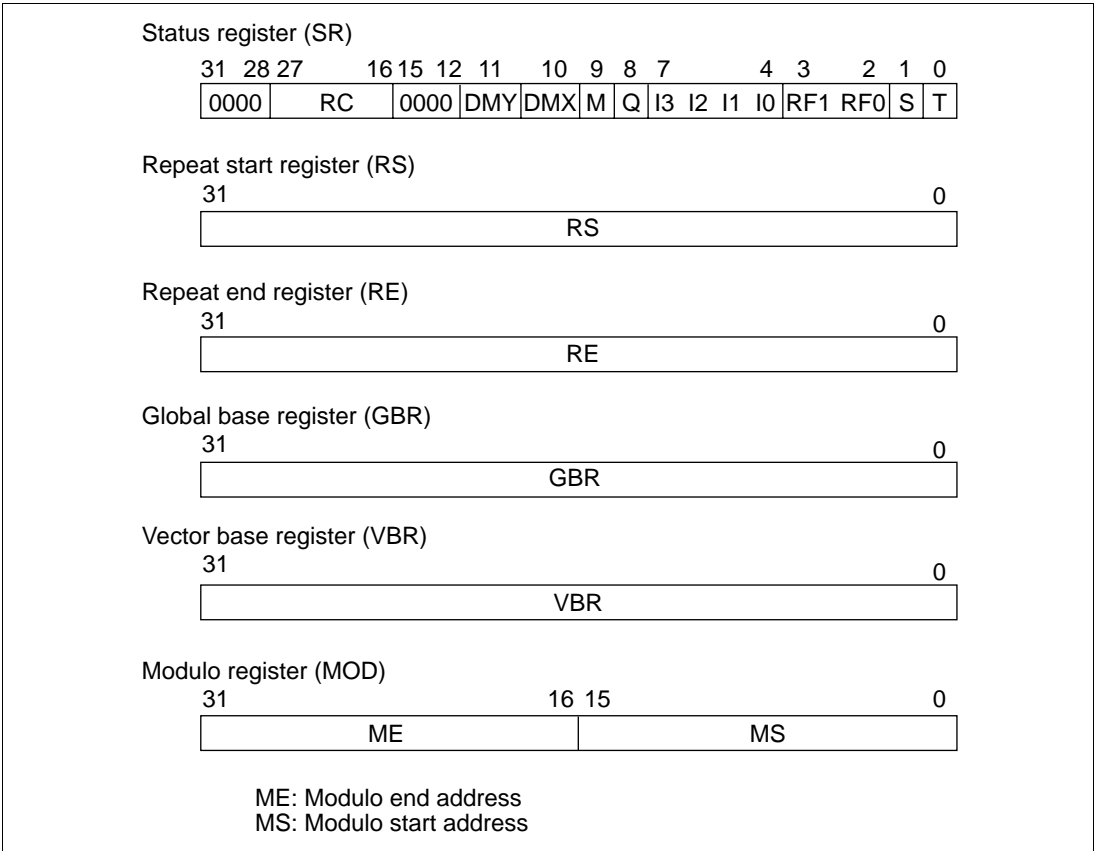

Figure 2.2 Control Register Configuration

Table 2.1 SR Register Bits

Bit	Name (Abbreviation)	Function
27–16	Repeat counter (RC)	Designate the repeat count (2–4095) for repeat (loop) control
11	Y pointer usage modulo addressing designation (DMY)	1: modulo addressing mode becomes valid for Y memory address pointer, Ay (R6, R7)
10	X pointer usage modulo addressing designation (DMX)	1: modulo addressing mode becomes valid for X memory address pointer, Ax (R4, R5)
9	M bit	Used by the DIV0S/U, DIV1 instructions
8	Q bit	Used by the DIV0S/U, DIV1 instructions
7–4	Interrupt request mask (I3–I0)	Indicate the receive level of an interrupt request (0 to 15)
3–2	Repeat flags (RF1, RF0)	Used in zero overhead repeat (loop) control. Set as below for an SETRC instruction For 1 step repeat 00 RE—RS=–4 For 2 step repeat 01 RE—RS=–2 For 3 step repeat 11 RE—RS=0 For 4 steps or more 10 RE—RS>0
1	Saturation arithmetic bit (S)	Used with MAC instructions and DSP instructions 1: Designates saturation arithmetic (prevents overflows)
0	T bit	For MOV _T , CMP/cond, TAS, TST, BT, BT/S, BF, BF/S, SETT, CLRT and DT instructions, 0: represents false 1: represents true For ADDV/ADDC, SUBV/SUBC, DIV0U/DIV0S, DIV1, NEG _C , SHAR/SHAL, SHLR/SHLL, ROTR/ROTL and ROTCR/ROTCL instructions, 1: represents occurrence of carry, borrow, overflow or underflow
31–28 15–12	0 bit	0: 0 is always read out; write a 0

There are dedicated load/store instructions for accessing the RS, RE and MOD registers. For example, the RS register is accessed as follows.

```
LDC    Rm,RS;      Rm→RS
LDC.L  @Rm+,RS;    (Rm)→RS,Rm+4→Rm
STC    RS,Rn;      RS→Rn
STC.L  RS,@-Rn;    Rn-4→Rn,RS→(Rn)
```

The following instructions set addresses in the RS, RE registers for zero overhead repeat control:

```
LDRS   @(disp,PC);  disp×2 + PC→RS
LDRE   @(disp,PC);  disp×2 + PC→RE
```

The GBR register and VBR register are the same as the previous SuperH microprocessor registers. An RC counter and four control bits (DMX bit, DMY bit, RF1 bit, RF0 bit) have been added to the SR register. The RS, RE and MOD registers are new registers.

2.1.3 System Registers

System registers consist of four 32-bit registers: high and low multiply and accumulate registers (MACH and MACL), the procedure register (PR), and the program counter (PC). The MACH and MACL store the results of multiplication or multiply and accumulate operations*. The PR stores the return address from the subroutine procedure. The PC indicates the address of the program in execution; it controls the flow of the processing. The PC indicates the fourth byte after the instruction currently being executed. These registers are the same as those in the SuperH microprocessor.

Note: These are used only when executing an instruction that was supported by SH-1 and SH-2. They are not used for newly added multiplication instructions (PMULS).

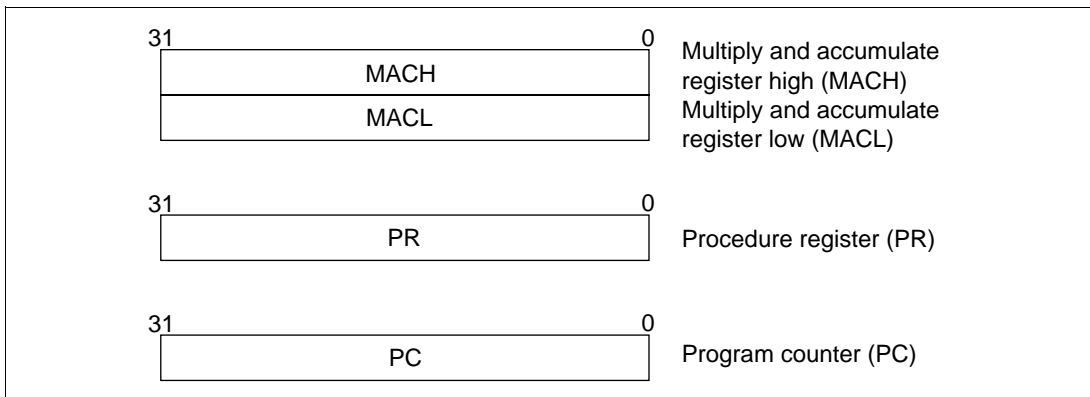

Figure 2.3 System Register Configuration

In addition, among the DSP unit usage registers (DSP registers) described in 2.1.4 DSP Registers, the DSP status register (DSR) and the five registers A0, X0, X1, Y0 and Y1 of the eight data registers are treated as system registers. Among these, the A0 is a 40-bit register, but when data is output from the A0 register, the guard bit section (A0G) is disregarded; when data is input to the A0 register, the MSB of the data is copied into the guard bit section (A0G).

2.1.4 DSP Registers

The DSP unit has eight data registers and one control register as its DSP registers.

The DSP data registers are comprised of the two 40-bit registers A0 and A1, and the six 32-bit registers M0, M1, X0, X1, Y0 and Y1. The A0 and A1 registers have the 8-bit guard bits A0G and A1G, respectively.

The DSP data registers are used for the transfer and processing of the DSP data of DSP instruction operands. There are three types of instructions that access DSP data registers: those for DSP data processing, and those for X or Y data transfer processing.

The control register is the 32-bit DSP status register (DSR) that represents operation results. The DSR register has bits that represent operation results, a signed greater than bit (GT), a zero bit (Z), a negative value bit (N), an overflow bit (V), a DSP status bit (DC: DSP condition), and a status selection bit (CS: condition select) for controlling DC bit setting.

The DC bit represents one status flag and is very similar to the SuperH microprocessor CPU core T bit. For conditional DSP type instructions, DSP data processing execution is controlled in accordance with the DC bit. This control is related to execution in the DSP unit only, and only DSP registers are updated. It bears no relation to address calculation or such SuperH microprocessor CPU core execution instructions as load/store instructions. The control bits CS (bits 2 to 0) designate the status for setting the DC bit.

DSP type instructions are comprised of unconditional DSP type instructions and conditional DSP type instructions. The status and DC bits are updated in unconditional DSP type data processing, with the exception of the PMULS, MOVX, MOVY and MOVS instructions. Conditional DSP type instructions are executed according to the status of the DC bit, but regardless of whether or not they are executed, the DSR register is not updated.

Figure 2.4 shows the DSP registers. The DSR register bit functions are shown in table 2.2.

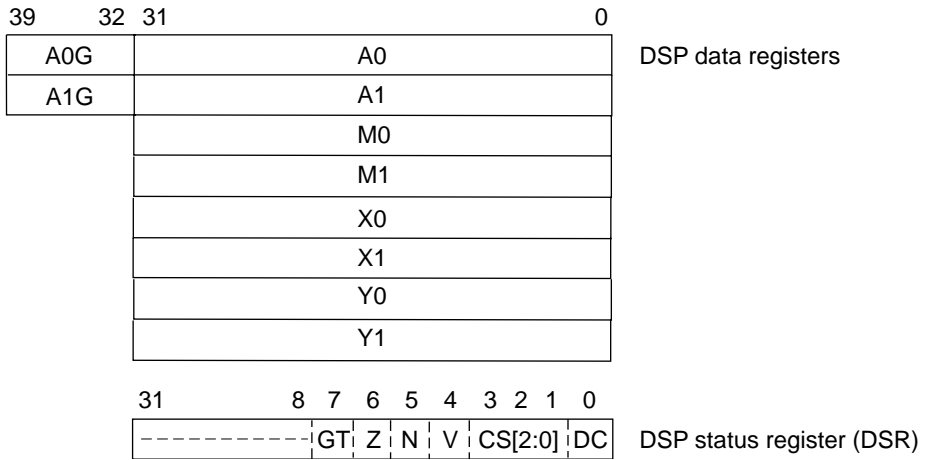

Figure 2.4 DSP Register Configuration

Table 2.2 DSR Register Bits

Bit	Name (Abbreviation)	Function
31–8	Reserved bits	0: Always read out; always use 0 as a write value
7	Signed greater than bit (GT)	Indicates that the operation result is positive (excepting 0), or that operand 1 is greater than operand 2 1: Operation result is positive, or operand 1 is greater
6	Zero bit (Z)	Indicates that the operation result is zero (0), or that operand 1 is equal to operand 2 1: Operation result is zero (0), or equivalence
5	Negative bit (N)	Indicates that the operation result is negative, or that operand 1 is smaller than operand 2 1: Operation result is negative, or operand 1 is smaller
4	Overflow bit (V)	Indicates that the operation result has overflowed 1: Operation result has overflowed
3–1	Status selection bits (CS)	Designate the mode for selecting the operation result status set in the DC bit Do not set either 110 or 111 000: Carry/borrow mode 001: Negative value mode 010: Zero mode 011: Overflow mode 100: Signed greater mode 101: Signed above mode
0	DSP status bit (DC)	Sets the status of the operation result in the mode designated by the CS bits 0: Designated mode status not realized (unrealized) 1: Designated mode status realized

2.1.5 Notes on Guard Bits and Overflow Treatment

DSP unit data operations are fundamentally performed as 32-bit, but these operations are always executed with a 40-bit length including the 8-bit guard section. When the guard bit section does not match the value of the 32-bit section MSB, the operation result is treated as an overflow. In this case, the N bit indicates the correct status of the operation result regardless of the existence or not of an overflow. This is so even if the destination operand is a 32-bit length register. The 8-bit section guard bits are always presupposed and each status flag is updated.

When place overflows occur so that the correct result cannot be displayed even when the guard bits are used, the N flag cannot indicate the correct status.

2.1.6 Initial Values of Registers

Table 2.3 lists the values of the registers after reset.

Table 2.3 Initial Values of Registers

Classification	Register	Initial Value
General registers	R0–R14	Undefined
	R15 (SP)	Value of the SP in the vector address table
Control registers	SR	Bits I3–I0 are 1111 (H'F), the reserved bits, RC, DMY, and DMX are 0, and other bits are undefined
	RS	Undefined
	RE	
	GBR	Undefined
	VBR	H'00000000
	MOD	Undefined
System registers	MACH, MACL, PR	Undefined
	PC	Value of the PC in the vector address table
DSP registers	A0, A0G, A1, A1G, M0, M1, X0, X1, Y0, Y1	Undefined
	DSR	H'00000000

2.2 Data Formats

2.2.1 Data Format in Registers

Register operand data size is always longword (32 bits). When loading data from memory into a register, if the memory operand is a byte (8 bits) or a word (16 bits), it is sign-extended into a longword, then loaded into the register.

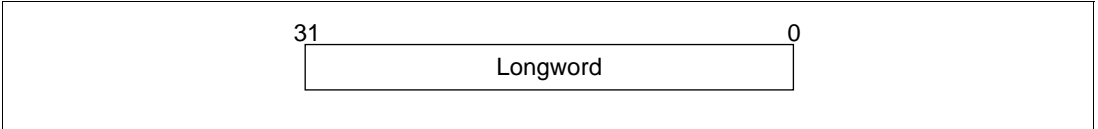

Figure 2.5 Register Data Format

2.2.2 Data Formats in Memory

These formats are classified into bytes, words, and longwords.

Place byte data in any address, word data from $2n$ addresses, and longword data from $4n$ addresses. An address error will occur if accesses are made from any other boundary. In such cases, the access results cannot be guaranteed. In particular, the stack area referred to by the hardware stack pointer (SP, R15) stores the program counter (PC) and status register (SR) as longwords, so establish the hardware stack pointer so that a $4n$ value will always result.

To enable sharing of the processor accessing memory in little-endian mode and memory, the CS2, 4 space (area 2, 4) has a function that allows access in little-endian mode. The order of byte data differs between little-endian mode and normal big-endian mode.

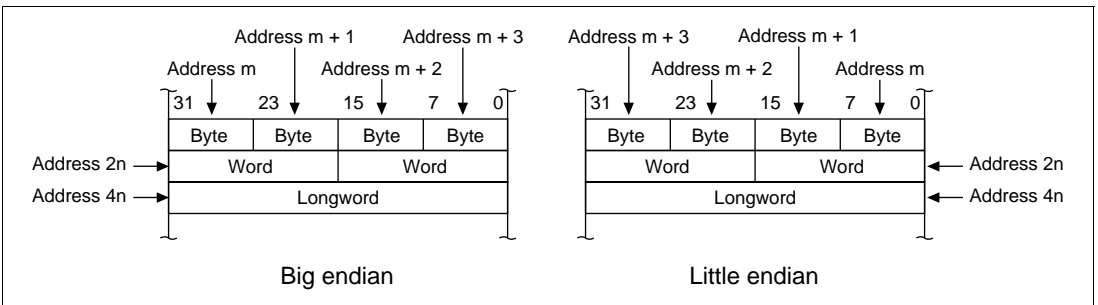

Figure 2.6 Data Formats in Memory

2.2.3 Immediate Data Format

Byte immediate data is placed in an instruction code.

With the MOV, ADD, and CMP/EQ instructions, immediate data is sign-extended and operated in registers as longword data. Immediate data accessed by the TST, AND, OR, and XOR instructions is zero-extended and handled as longword data. Consequently, AND instructions with immediate data always clear the upper 24 bits of the destination register.

Word or longword immediate data is not located in the instruction code; it should be placed in a memory table. Use an immediate data transfer instruction (MOV) to refer the memory table using the PC relative addressing mode with displacement.

2.2.4 DSP Type Data Formats

This chip has three different types of data format that correspond to various instructions. These are the fixed-point data format, the integer data format, and the logical data format.

The DSP type fixed-point data format has a binary point fixed between bits 31 and 30. There are three types: with guard bits, without guard bits, and multiplication input; each with different valid bit lengths and value ranges.

The DSP type integer data format has a binary point fixed between bits 16 and 15. There are three types: with guard bits, without guard bits, and shift amount; each with different valid bit lengths and value ranges. The shift amount of the arithmetic shift (PSHA) has a 7 bit range and can express values from -64 to $+63$, but the actual valid values are from -32 to $+32$. In the same manner, the shift amount of the logical shift has a 6 bit range, but the actual valid values are from -16 to $+16$.

The DSP type logical data format does not have a decimal point.

The data format and valid data length are determined by the instructions and DSP registers.

Figure 2.7 shows the three DSP type data formats and binary point positions. The SuperH type data format is also shown for reference.

DSP fixed decimal point data

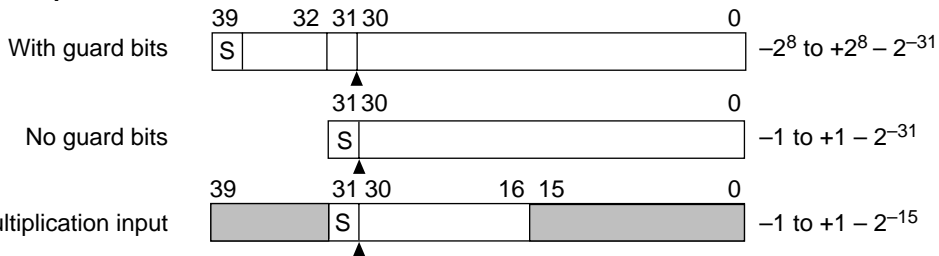

DSP integer data

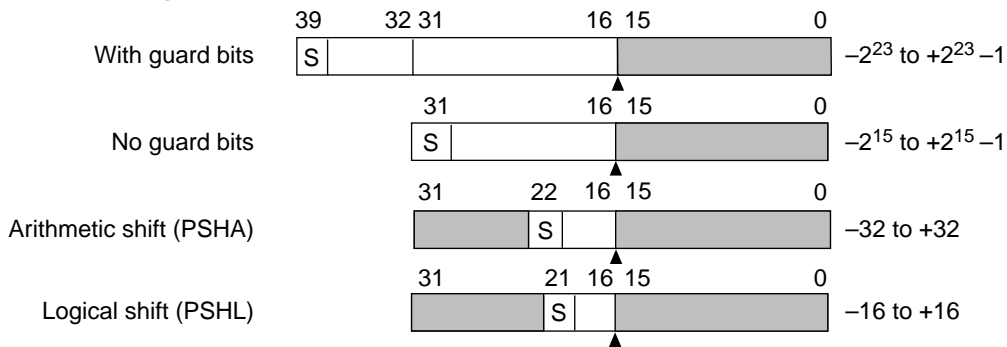

DSP logical data

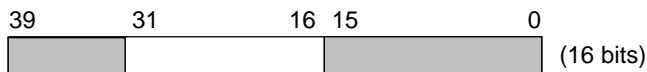

SuperH integer (word) (Reference)

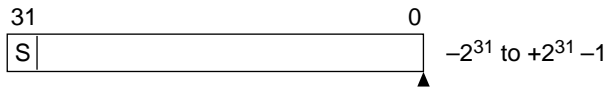

- S : Sign bit
- ▲ : Binary decimal point
- : Unrelated to processing (ignored)

Figure 2.7 DSP Type Data Formats

2.2.5 DSP Type Instructions and Data Formats

The DSP data format and valid data length are determined by DSP type instructions and DSP registers. There are three types of instructions that access DSP data registers, DSP data processing, X, Y data transfer processing, and single data transfer processing instructions.

DSP Data Processing: The guard bits (bits 39–32) are valid when the A0 and A1 registers are used as source registers in DSP fixed-point data processing. When any registers other than A0, A1 (e.i., M0, M1, X0, X1, Y0, Y1 registers) are used as source registers, the sign-extended part of that register data becomes the bits 39 to 32 data. When the A0 and A1 registers are used as destination registers, the guard bits (bits 39–32) are valid. When any registers other than A0, A1 are used as destination registers, bits 39 to 32 of the result data are disregarded.

Processing for DSP integer data is the same as the DSP fixed-point data processing. However, the lower word (the lower 16 bits, bits 15–0) of the source register is disregarded. The lower word of the destination register is cleared to 0.

In DSP logical data processing, the upper word (the upper 16 bits, bits 31–16) of the source register is valid. The lower word and the guard bits of the A0, A1 registers are disregarded. The upper word of the destination register is valid. The lower word and the guard bits of the A0, A1 registers are cleared to 0.

X, Y Data Transfers: The MOVX.W and MOVY.W instructions access X, Y memory via the 16-bit X, Y data buses. The data loaded into registers and data stored from registers is always the upper word (the upper 16 bits, bits 31–16).

When loading, the MOVX.W instruction loads X memory, with the X0 and X1 registers as the destination registers. The MOVY.W instruction loads Y memory, with the Y0 and Y1 registers as the destination registers. Data is stored in the upper word of the register; the lower word is cleared to 0.

The upper word data of the A0, A1 registers can be stored in X or Y memory with these data transfer instructions, but storing is not possible from any other registers. The guard bits and the lower word of the A0, A1 registers are disregarded.

Single Data Transfers: The MOVS.W and MOVS.L instructions can access any memory via the data bus (CDB). All DSP registers are connected to the CDB bus, and they can become source or destination registers during data transfers. The two data transfer modes are word and longword.

In word mode, data is loaded to and stored in the upper word of the DSP register, with the exception of the A0G, A1G registers. In longword mode, data is loaded to and stored in the 32 bits of the DSP register, with the exception of the A0G, A1G registers. The A0G, A1G registers can be treated as independent registers during single data transfers. The load/store data length for the A0G, A1G registers is 8 bits.

If DSP registers are used as source registers in word mode, when data is stored from any registers other than A0G, A1G, the data in the upper word of the register is transferred. In the case of the A0, A1 registers, the guard bits are disregarded. When the A0G, A1G registers are the source registers in word mode, only 8 bits of the data are stored from the registers; the upper bits are sign-extended.

If the DSP registers are used as destination registers in word mode, the load is to the upper word of the register, with the exception of A0G, A1G. When data is loaded to any register other than A0G, A1G, the lower word of the register is cleared to 0. In the case of the A0, A1 registers, the data sign is extended and stored in the guard bits; the lower word is cleared to 0. When the A0G, A1G registers are the destination registers in word mode, the least significant 8 bits of the data are loaded into the registers; the A0, A1 registers are not zero cleared but retain their previous values.

If the DSP registers are used as source registers in longword mode, when data is stored from any registers other than A0G, A1G, the 32 bits (data) of the register are transferred. When the A0, A1 registers are used as the source registers the guard bits are disregarded. When the A0G, A1G registers are the source registers in longword mode, only 8 bits of the data are stored from the registers; the upper bits are sign-extended.

If the DSP registers are used as destination registers in longword mode, the load is to the 32 bits of the register, with the exception of A0G, A1G. In the case of the A0, A1 registers, the data sign is extended and stored in the guard bits. When the A0G, A1G registers are the destination registers in longword mode, the least significant 8 bits of the data are loaded into the registers; the A0, A1 registers are not zero cleared but retain their previous values.

Tables 2.4 and 2.5 indicate the register data formats for DSP instructions. Some registers cannot be accessed by certain instructions. For example, the PMULS instruction can designate the A1 register as a source register but cannot designate A0 as such. Refer to the instruction explanations for details.

Figure 2.8 shows the relationship between the buses and the DSP registers during transfers.

Table 2.4 Source Register Data Formats for DSP Instructions

Register	Instruction	Guard Bits		Register Bits		
		39–32		31–16	15–0	
A0, A1	DSP operation	Fixed decimal, PDMSB, PSHA	40-bit data			
		Integer	24-bit data		—	
		Logic, PSHL, PMULS	—	16-bit data		
	Data transfer	MOVX.W, MOVY.W, MOVS.W				
		MOVS.L			32-bit data	
A0G, A1G	Data transfer	MOVS.W	Data	—	—	
		MOVS.L				
X0, X1, Y0, Y1, M0, M1	DSP operation	Fixed decimal, PDMSB, PSHA	Sign*	32-bit data		
		Integer		16-bit data	—	
		Logic, PSHL, PMULS	—			
	Data transfer	MOVS.W				
		MOVS.L			32-bit data	

Note: * The sign is extended and stored in the ALU's guard bits.

Table 2.5 Destination Register Data Formats for DSP Instructions

Register	Instruction	Guard Bits		Register Bits	
		39–32		31–16	15–0
A0, A1	DSP operation	Fixed decimal, PSHA, PMULS	(Sign extend)	40-bit result	
		Integer, PDMSB		24-bit result	Clear to 0
		Logic, PSHL	Clear to 0	16-bit result	
	Data transfer	MOVS.W	Sign extend		
		MOVS.L		32-bit data	
A0G, A1G	Data transfer	MOVS.W	Data	Not updated	Not updated
		MOVS.L			
X0, X1, Y0, Y1, M0, M1	DSP operation	Fixed decimal, PSHA, PMULS	—	32-bit result	
		Integer, logic, PDMSB, PSHL		16-bit result	Clear to 0
		Data transfer	MOVX.W, MOVY.W, MOVS.W		
		MOVS.L		32-bit data	

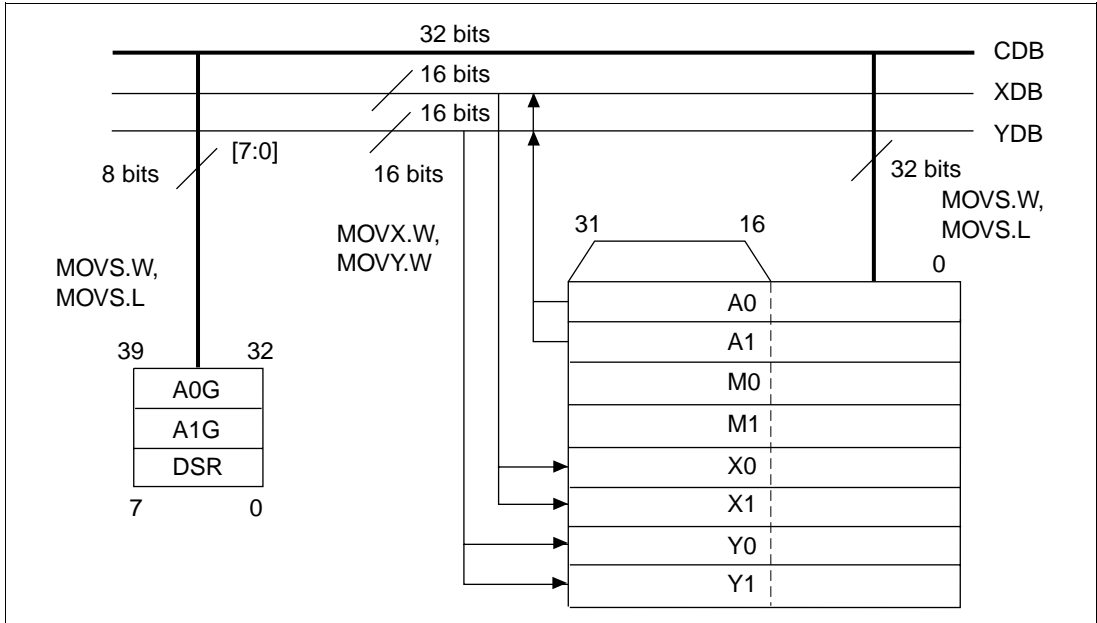

Figure 2.8 DSP Register-Bus Relationship during Data Transfers

2.3 CPU Core Instruction Features

The CPU core instructions are RISC type. The characteristics are as follows.

16-Bit Fixed Length: All instructions are 16 bits long, increasing program code efficiency.

One Instruction per Cycle: The microprocessor can execute basic instructions in one cycle using the pipeline system. One state equals 16.0 ns when operating at 62.5 MHz.

Data Length: Longword is the basic data length for all operations. Memory can be accessed in bytes, words, or longwords. Byte or word data accessed from memory is sign-extended and handled as longword data. Immediate data is sign-extended for arithmetic operations or zero-extended for logic operations. It also is handled as longword data.

Table 2.6 Sign Extension of Word Data

SH7616 CPU	Description	Example of Conventional CPU
MOV.W @ (disp,PC),R1	Data is sign-extended to 32 bits, and R1 becomes H'00001234. It is next operated upon by an ADD instruction	ADD.W #H'1234,R0
ADD R1,R0		
.....		
.DATA.W H'1234		

Note: @ (disp, PC) accesses the immediate data.

Load-Store Architecture: Basic operations are executed between registers. For operations that involve memory access, data is loaded to the registers and executed (load-store architecture). However, Instructions such as AND manipulating bits, are executed directly in memory.

Delayed Branches: Such instructions as unconditional branches are delayed branch instructions. In the case of delayed branch instructions, the branch occurs after execution of the instruction immediately following the delayed branch instruction (slot instruction). This reduces pipeline disruption during branching.

The branching operation of the delayed branch occurs after execution of the slot instruction. However, with the exception of such branch operations as register updating, execution of instructions is performed with the order of delayed branch instruction, then delayed slot instruction.

For example, even if the contents of a register storing a branch destination address are modified by a delayed slot, the branch destination address will still be the contents of the register before the modification.

Table 2.7 Delayed Branch Instructions

SH7616 CPU	Description	Example of Conventional CPU
BRA TRGET	Executes an ADD before branching to TRGET	ADD.W R1,R0
ADD R1,R0		BRA TRGET

Multiplication/Multiply-Accumulate Operation: $16 \times 16 \rightarrow 32$ multiplications execute in one to three cycles, and $16 \times 16 + 64 \rightarrow 64$ multiply-accumulate operations execute in two to three cycles. $32 \times 32 \rightarrow 64$ multiplications and $32 \times 32 + 64 \rightarrow 64$ multiply-accumulate operations execute in two to four cycles.

T Bit: The T bit in the status register (SR) changes according to the result of a comparison, and conditional branches occur in accordance with its true or false status. The number of instructions modifying the T bit is kept to a minimum to improve the processing speed.

Table 2.8 T Bit

SH7616 CPU		Description	Example of Conventional CPU	
CMP/GE	R1,R0	T bit is set when $R0 \geq R1$.	CMP.W	R1,R0
BT	TRGET0	The program branches to TRGET0 when $R0 \geq R1$.	BGE	TRGET0
BF	TRGET1	The program branches to TRGET1 when $R0 < R1$	BLT	TRGET1
ADD	#-1,R0	T bit is not changed by ADD. T bit is set when $R0 = 0$. The program branches when $R0 = 0$	SUB.W	#1,R0
CMP/EQ	#0,R0		BEQ	TRGET
BT	TRGET			

Immediate Data: Byte immediate data resides in instruction code. Word or longword immediate data is not input in instruction codes but is stored in a memory table. An immediate data transfer instruction (MOV) accesses the memory table using the PC relative addressing mode with displacement.

Table 2.9 Immediate Data Accessing

Classification	SH7616 CPU		Example of Conventional CPU	
8-bit immediate	MOV	#H'12,R0	MOV.B	#H'12,R0
16-bit immediate	MOV.W	@(disp,PC),R0	MOV.W	#H'1234,R0
DATA.W H'1234		
32-bit immediate	MOV.L	@(disp,PC),R0	MOV.L	#H'12345678,R0
DATA.L H'12345678		

Note: @(disp, PC) accesses the immediate data.

Absolute Address: When data is accessed by absolute address, the value already in the absolute address is placed in the memory table. Loading the immediate data when the instruction is executed transfers that value to the register and the data is accessed in the indirect register addressing mode.

Table 2.10 Absolute Address Accessing

Classification	SH7616 CPU	Example of Conventional CPU
Absolute address	MOV.L @(disp,PC),R1	MOV.B @H'12345678,R0
	MOV.B @R1,R0	
	
	.DATA.L H'12345678	

16-Bit/32-Bit Displacement: When data is accessed by 16-bit or 32-bit displacement, the pre-existing displacement value is placed in the memory table. Loading the immediate data when the instruction is executed transfers that value to the register and the data is accessed in the indirect indexed register addressing mode.

Table 2.11 Displacement Accessing

Classification	SH7616 CPU	Example of Conventional CPU
16-bit displacement	MOV.W @(disp,PC),R0	MOV.W @(H'1234,R1),R2
	MOV.W @(R0,R1),R2	
	
	.DATA.W H'1234	

2.4 Instruction Formats

2.4.1 CPU Instruction Addressing Modes

The addressing modes and effective address calculation for instructions executed by the CPU core are listed in table 2.12.

Table 2.12 CPU Instruction Addressing Modes and Effective Addresses

Addressing Mode	Instruction Format	Effective Addresses Calculation	Equation
Direct register addressing	Rn	The effective address is register Rn (The operand is the contents of register Rn)	—
Indirect register addressing	@Rn	The effective address is the content of register Rn 	Rn
Post-increment indirect register addressing	@Rn+	The effective address is the content of register Rn. A constant is added to the content of Rn after the instruction is executed. 1 is added for a byte operation, 2 for a word operation, and 4 for a longword operation 	Rn (After the instruction executes) Byte: $Rn + 1 \rightarrow Rn$ Word: $Rn + 2 \rightarrow Rn$ Longword: $Rn + 4 \rightarrow Rn$
Pre-decrement indirect register addressing	@-Rn	The effective address is the value obtained by subtracting a constant from Rn. 1 is subtracted for a byte operation, 2 for a word operation, and 4 for a longword operation 	Byte: $Rn - 1 \rightarrow Rn$ Word: $Rn - 2 \rightarrow Rn$ Longword: $Rn - 4 \rightarrow Rn$ (Instruction executed with Rn after calculation)

Table 2.12 CPU Instruction Addressing Modes and Effective Addresses (cont)

Addressing Mode	Instruction Format	Effective Addresses Calculation	Equation
Indirect register addressing with displacement	@(disp:4, Rn)	The effective address is Rn plus a 4-bit displacement (disp). The value of disp is zero-extended, and remains the same for a byte operation, is doubled for a word operation, and is quadrupled for a longword operation	Byte: $Rn + disp$ Word: $Rn + disp \times 2$ Longword: $Rn + disp \times 4$
Indirect indexed register addressing	@(R0, Rn)	The effective address is the Rn value plus R0	$Rn + R0$
Indirect GBR addressing with displacement	@(disp:8, GBR)	The effective address is the GBR value plus an 8-bit displacement (disp). The value of disp is zero-extended, and remains the same for a byte operation, is doubled for a word operation, and is quadrupled for a longword operation	Byte: $GBR + disp$ Word: $GBR + disp \times 2$ Longword: $GBR + disp \times 4$

Table 2.12 CPU Instruction Addressing Modes and Effective Addresses (cont)

Addressing Mode	Instruction Format	Effective Addresses Calculation	Equation
Indirect indexed GBR addressing	@(R0, GBR)	The effective address is the GBR value plus the R0	$GBR + R0$
PC relative addressing with displacement	@(disp:8, PC)	The effective address is the PC value plus an 8-bit displacement (disp). The value of disp is zero-extended, is doubled for a word operation, and is quadrupled for a longword operation. For a longword operation, the lowest two bits of the PC value are masked	<p>Word: $PC + disp \times 2$</p> <p>Longword: $PC \& H'FFFFFFC + disp \times 4$</p>

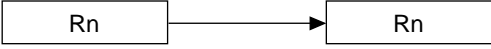
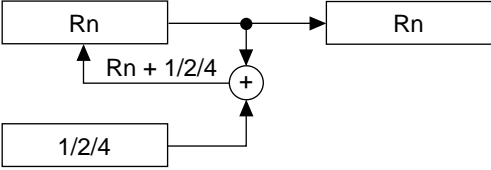
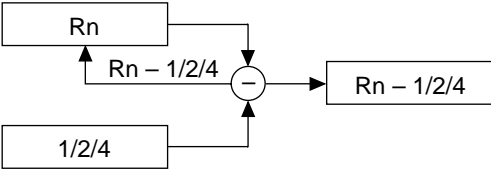
Table 2.12 CPU Instruction Addressing Modes and Effective Addresses (cont)

PC relative addressing	disp:8	The effective address is the PC value sign-extended with an 8-bit displacement (disp), doubled, and added to the PC value	$PC + disp \times 2$
<hr/>			
	disp:12	The effective address is the PC value sign-extended with a 12-bit displacement (disp), doubled, and added to the PC value	$PC + disp \times 2$
<hr/>			
	Rn	The effective address is the register PC value plus Rn	$PC + Rn$
<hr/>			
Immediate addressing	#imm:8	The 8-bit immediate data (imm) for the TST, AND, OR, and XOR instructions are zero-extended	—
	#imm:8	The 8-bit immediate data (imm) for the MOV, ADD, and CMP/EQ instructions are sign-extended	—
	#imm:8	The 8-bit immediate data (imm) for the TRAPA instruction is zero-extended and is quadrupled	—

2.4.2 DSP Data Addressing

There are two different kinds of memory accesses with DSP instructions. One type is with the X, Y data transfer instructions (MOVX.W, MOVY.W), and the other is with the single data transfer instructions (MOVS.W, MOVS.L). The data addressing differs between these two types of instructions. Table 2.13 shows a summary of the data transfer instructions.

Table 2.13 Overview of Data Transfer Instructions

Classification	X, Y Data Transfer Processing (MOVX.W, MOVY.W)	Single Data Transfer Processing (MOVS.W, MOVS.L)
Address registers	Ax: R4, R5; Ay: R6, R7	As: R2, R3, R4, R5
Index registers	Ix: R8, Iy: R9	Is: R8
Addressing	Nop/Inc(+2)/index addition: post-update	Nop/Inc(+2,+4)/index addition: post-update
	—	Dec(-2,-4): pre-update
Modulo addressing	Possible	Not possible
Data bus	XDB, YDB	CDB
Data length	16 bit (word)	16 bit/32 bit (word/longword)
Bus contention	None	Yes
Memory	X, Y data memory	All memory spaces
Source registers	Dx, Dy: A0, A1	Ds: A0/A1, M0/M1, X0/X1, Y0/Y1, A0G, A1G
Destination registers	Dx: X0/X1; Dy: Y0/Y1	Ds: A0/A1, M0/M1, X0/X1, Y0/Y1, A0G, A1G

X, Y Data Addressing: Among the DSP instructions, the MOVX.W and MOVY.W instructions can be used to simultaneously access X, Y data memory. The DSP instructions have two address pointers for simultaneous accessing of X, Y data memory. Only pointer addressing is possible with DSP instructions; there is no immediate addressing. The address registers are divided into two; the R4, R5 registers become the X memory address register (Ax), and the R6, R7 registers become the Y memory address register (Ay). The following three types of addressing exist with X, Y data transfer instructions.

1. Non-updated address registers: The Ax, Ay registers are address pointers. They are not updated.
2. Add index registers: The Ax, Ay registers are address pointers. The Ix, Iy register values are added to them, respectively, after the data transfer (post-update).
3. Increment address registers: The Ax, Ay registers are address pointers. The value +2 is added to each of them after the data transfer (post-update).

Each of the address pointers has an index register. The R8 register becomes the index register (Ix) of the X memory address register (Ax), and the R9 register becomes the index register (Iy) of the Y memory address register (Ay).

The X, Y data transfer instructions are processed in word lengths. X, Y data memory is accessed in 16 bit lengths. This is why the increment processing adds 2 to the address registers. In order to decrement, set -2 in the index register and designate add index register addressing. During X, Y data addressing, only bits 1 to 15 of the address pointer are valid. Always write a 0 to bit 0 of the address pointer and the index register during X, Y data addressing.

Figure 2.9 shows the X, Y data transfer addressing. When X memory and Y memory are accessed using the X, Y bus, the upper word of Ax (R4 or R5) and Ay (R6 or R7) is ignored. The result of @Ay+ and @Ay+Iy is stored in the lower word of Ay, and the upper word retains its original value.

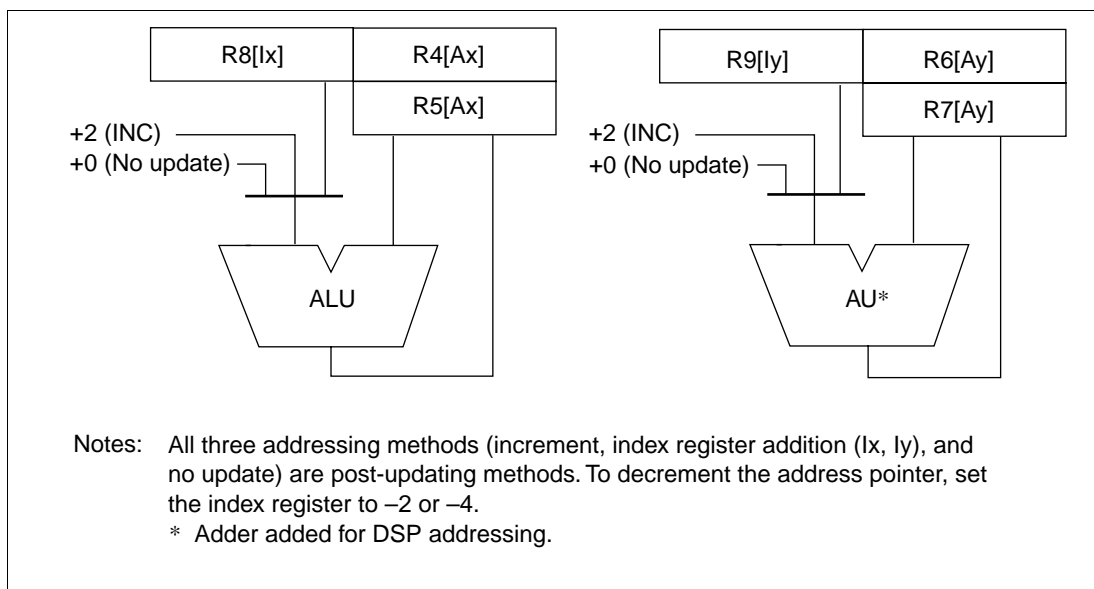

Figure 2.9 X, Y Data Transfer Addressing

Single Data Addressing: Among the DSP instructions, the single data transfer instructions (MOVS.W and MOVS.L) are used to either load data into DSP registers or to store it from them. With these instructions, the registers R2 to R5 are used as address registers (As) for the single data transfers.

The four following data addressing instructions exist for single data transfer instructions.

1. Non-updated address registers: The As registers are address pointers. They are not updated.
2. Add index registers: The As registers are address pointers. The Is register values are added to them after the data transfer (post-update).
3. Increment address registers: The As registers are address pointers. The value +2 or +4 is added after the data transfer (post-update).
4. Decrement address registers: The As registers are address pointers. The value -2 or -4 is added (+2 or +4 is subtracted) before the data transfer (pre-update).

The address pointer (As) uses the R8 register as an index register (Is).

Figure 2.10 shows the single data transfer addressing.

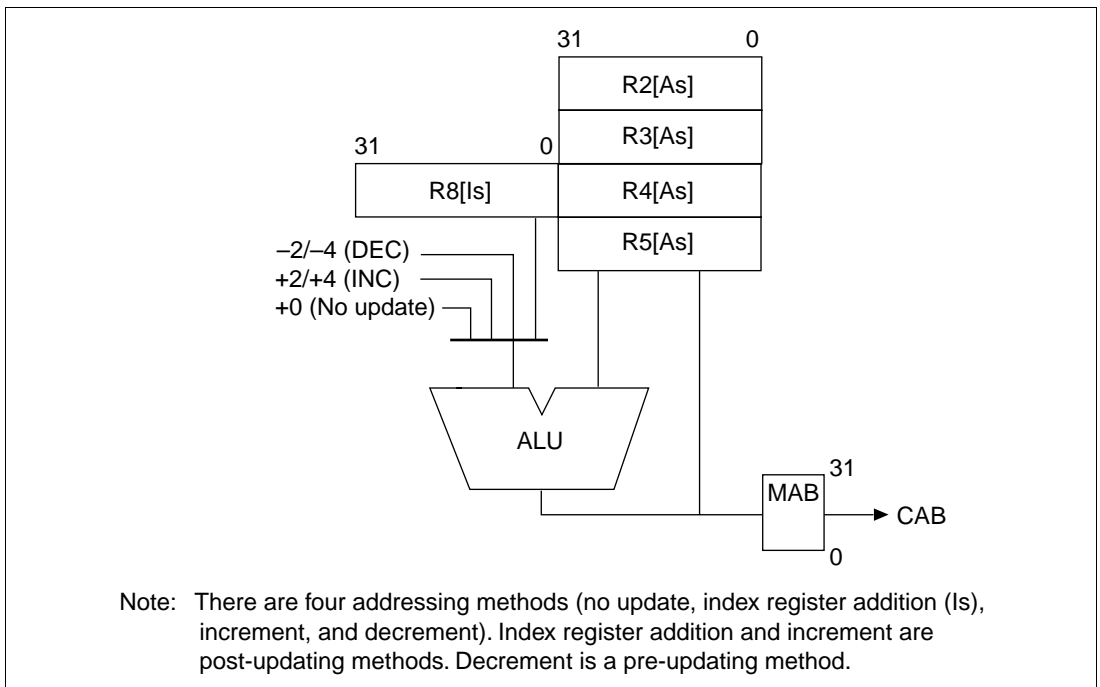

Figure 2.10 Single Data Transfer Addressing

Modulo Addressing: The chip has a modulo addressing mode, just as other DSPs do. Address registers are updated in the same manner as with other modes. When the address pointer value becomes the same as a previously established modulo end address, the address pointer becomes the modulo start address.

Modulo addressing is valid only with X, Y data transfer instructions (MOVX.W, MOVY.W). When the DMX bit of the SR register is set, the X address register enters modulo addressing mode; when the DMY bit of the SR register is set, the Y address register does so. Modulo addressing is valid only for either the X or the Y address register; it is not possible to make them both modulo addressing mode at the same time. Therefore, do not simultaneously set the DMX and DMY. If they happen to be set at the same time, only the DMY side is valid.

The MOD register is used to designate the start and end addresses of the modulo address area; it stores the MS (modulo start) and ME (modulo end). An example of MOD register (MS, ME) usage is indicated below.

```

MOV.L ModAddr,Rn;           Rn=ModEnd, ModStart
LDC Rn,MOD;                 ME=ModEnd, MS=ModStart
ModAddr: .DATA.W    mEnd;   ModEnd
          .DATA.W    mStart; ModStart

ModStart: .DATA
          :
ModEnd:   .DATA

```

Designate the start and end addresses in MS and ME, and then set the DMX or DMY bit to 1. The contents of the address register are compared with ME. If they match ME, the start address MS is stored in the address register. The lower 16 bits of the address register are compared with ME. The maximum modulo size is 64 kbytes. This is sufficient for X, Y data memory accesses. Figure 2.11 shows a block diagram of modulo addressing.

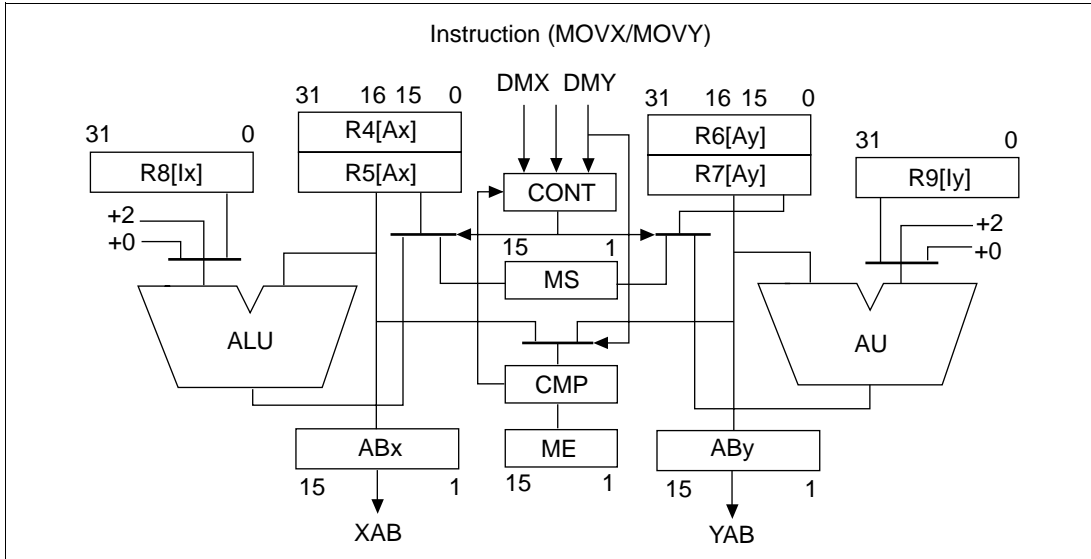

Figure 2.11 Modulo Addressing

An example of modulo addressing is indicated below:

MS=H'E008; ME=H'E00C; R4=H'1000E008;

DMX=1; DMY=0; (sets modulo addressing for address register Ax (R4, R5))

The R4 register changes as follows due to the above settings.

R4: H'1000E008

Inc. R4: H'1000E00A

Inc. R4: H'1000E00C

Inc. R4: H'1000E008 (becomes the modulo start address because the modulo end address occurred)

Data is placed so that the upper 16 bits of the modulo start and end addresses become identical. This is so because the modulo start address replaces only the lower 15 bits of the address register, excepting bit 0.

Note: When using add index with DSP data addressing, there are cases where the value is exceeded without the address pointer matching the ME. In such cases, the address pointer does not return to the modulo start address. Bit 0 is disregarded not only for modulo addressing, but also during X, Y data addressing, so always write 0 to the 0 bits of the address pointer, index register, MS, and ME.

DSP Addressing Operation: The DSP addressing operation in the item stage (EX) of the pipeline, including modulo addressing, is indicated below.

```

if ( Operation is MOVX.W MOVY.W ) {
    ABx=Ax; ABY=Ay;
    /* memory access cycle uses ABx and ABY. The addresses to be used have
not been updated */

    /* Ax is one of R4,5 */
    if ( DMX==0 || DMX==1 && DMY==1 ) Ax=Ax+(+2 or R8[Ix] or +0);
    /* Inc,Index,Not-Update */
    else if (!not-update) Ax=modulo( Ax, (+2 or R8[Ix]) );

    /* Ay is one of R6,7 */
    if ( DMY==0 ) Ay=Ay+(+2 or R9[Iy] or +0); /* Inc,Index,Not-Update */
    else if (! not-update) Ay=modulo( Ay, (+2 or R9[Iy]) );
}
else if ( Operation is MOV.S.W or MOV.S.L ) {
    if ( Addressing is Nop, Inc, Add-index-reg ) {
        MAB=As;
        /* memory access cycle uses MAB. The address to be used has not been
updated */
        /* As is one of R2-5 */
        As=As+(+2 or +4 or R8[Is] or +0); /* Inc.Index,Not-Update */
    else { /* Decrement, Pre-update */
        /* As is one of R2-5 */
        As=As+(-2 or -4);
        MAB=As;
        /* memory access cycle uses MAB. The address to be used has been updated
*/
    }

    /* The value to be added to the address register depends on addressing
operations.
For example, (+2 or R8[Ix] or +0) means that
        +2:          if operation is increment
        R8[Ix]:     if operation is add-index-reg
        +0:          if operation is not-update
*/

```

```
function modulo ( AddrReg, Index ) {  
    if ( AddrReg[15:0]==ME ) AddrReg[15:0]=MS;  
    else AddrReg=AddrReg+Index;  
    return AddrReg;  
}
```

2.4.3 Instruction Formats for CPU Instructions

The instruction format of instructions executed by the CPU core and the meanings of the source and destination operands are indicated below. The meaning of the operand depends on the instruction code. The symbols are used as follows:

- xxxx: Instruction code
- mmmm: Source register
- nnnn: Destination register
- iiiii: Immediate data
- dddd: Displacement

Table 2.14 Instruction Formats for CPU Instructions

Instruction Formats	Source Operand	Destination Operand	Example
0 format 15 0 <div style="border: 1px solid black; padding: 2px; display: inline-block;"> xxxx xxxx xxxx xxxx </div>	—	—	NOP
n format 15 0 <div style="border: 1px solid black; padding: 2px; display: inline-block;"> xxxx nnnn xxxx xxxx </div>	—	nnnn: Direct register	MOVT Rn
	Control register or system register	nnnn: Direct register	STS MACH,Rn
	Control register or system register	nnnn: Indirect pre-decrement register	STC.L SR,@-Rn
m format 15 0 <div style="border: 1px solid black; padding: 2px; display: inline-block;"> xxxx mmmm xxxx xxxx </div>	mmmm: Direct register	Control register or system register	LDC Rm,SR
	mmmm: Indirect post-increment register	Control register or system register	LDC.L @Rm+,SR
	mmmm: Indirect register	—	JMP @Rm
	mmmm: PC relative using Rm	—	BRAF Rm

Table 2.14 Instruction Formats for CPU Instructions (cont)

Instruction Formats	Source Operand	Destination Operand	Example				
nm format	mmmm: Direct register	nxxx: Direct register	ADD Rm,Rn				
15 <table border="1" style="width: 100%; text-align: center;"> <tr> <td style="width: 25%;">xxxx</td> <td style="width: 25%;">nnnn</td> <td style="width: 25%;">mmmm</td> <td style="width: 25%;">xxxx</td> </tr> </table> 0	xxxx	nnnn	mmmm	xxxx	mxxx: Direct register	nxxx: Indirect register	MOV.L Rm,@Rn
xxxx	nnnn	mmmm	xxxx				
	mxxx: Indirect post-increment register (multiply/accumulate)	MACH, MACL	MAC.W @Rm+,@Rn+				
	nxxx: Indirect post-increment register (multiply/accumulate)*						
	mxxx: Indirect post-increment register	nxxx: Direct register	MOV.L @Rm+,Rn				
	mxxx: Direct register	nxxx: Indirect pre-decrement register	MOV.L Rm,@-Rn				
	mxxx: Direct register	nxxx: Indirect indexed register	MOV.L Rm,@(R0,Rn)				
md format	mmmmddd: indirect register with displacement	R0 (Direct register)	MOV.B @(disp,Rm),R0				
15 <table border="1" style="width: 100%; text-align: center;"> <tr> <td style="width: 25%;">xxxx</td> <td style="width: 25%;">xxxx</td> <td style="width: 25%;">mmmm</td> <td style="width: 25%;">ddd</td> </tr> </table> 0	xxxx	xxxx	mmmm	ddd			
xxxx	xxxx	mmmm	ddd				
nd4 format	R0 (Direct register)	nnnnddd: Indirect register with displacement	MOV.B R0,@(disp,Rn)				
15 <table border="1" style="width: 100%; text-align: center;"> <tr> <td style="width: 25%;">xxxx</td> <td style="width: 25%;">xxxx</td> <td style="width: 25%;">nnnn</td> <td style="width: 25%;">ddd</td> </tr> </table> 0	xxxx	xxxx	nnnn	ddd			
xxxx	xxxx	nnnn	ddd				
nmd format	mmmm: Direct register	nnnnddd: Indirect register with displacement	MOV.L Rm,@(disp,Rn)				
15 <table border="1" style="width: 100%; text-align: center;"> <tr> <td style="width: 25%;">xxxx</td> <td style="width: 25%;">nnnn</td> <td style="width: 25%;">mmmm</td> <td style="width: 25%;">ddd</td> </tr> </table> 0	xxxx	nnnn	mmmm	ddd			
xxxx	nnnn	mmmm	ddd				
	mmmmddd: Indirect register with displacement	nxxx: Direct register	MOV.L @(disp,Rm),Rn				

Table 2.14 Instruction Formats for CPU Instructions (cont)

Instruction Formats	Source Operand	Destination Operand	Example
d format 15 0 <div style="border: 1px solid black; padding: 2px; display: inline-block;"> xxxx xxxx dddd dddd </div>	dddddddd: Indirect GBR with displacement	R0 (Direct register)	MOV.L @ (disp,GBR),R0
	R0(Direct register)	ddddddd: Indirect GBR with displacement	MOV.L R0,@ (disp,GBR)
	ddddddd: PC relative with displacement	R0 (Direct register)	MOVA @ (disp,PC),R0
	ddddddd: PC relative	—	BF label
d12 format 15 0 <div style="border: 1px solid black; padding: 2px; display: inline-block;"> xxxx dddd dddd dddd </div>	dddddddddd: PC relative	—	BRA label (label=disp+PC)
nd8 format 15 0 <div style="border: 1px solid black; padding: 2px; display: inline-block;"> xxxx nnnn dddd dddd </div>	dddddddd: PC relative with displacement	nnnn: Direct register	MOV.L @ (disp,PC),Rn
i format 15 0 <div style="border: 1px solid black; padding: 2px; display: inline-block;"> xxxx xxxx iiiiiiii </div>	iiiiiiii: Immediate	Indirect indexed GBR	AND.B #imm,@ (R0,GBR)
	iiiiiiii: Immediate	R0 (Direct register)	AND #imm,R0
	iiiiiiii: Immediate	—	TRAPA #imm
ni format 15 0 <div style="border: 1px solid black; padding: 2px; display: inline-block;"> xxxx nnnn iiiiiiii </div>	iiiiiiii: Immediate	nnnn: Direct register	ADD #imm,Rn

Note: * In multiply/accumulate instructions, nnnn is the source register.

2.4.4 Instruction Formats for DSP Instructions

New instructions have been added for digital signal processing. The new instructions are divided into the two following types.

1. Memory and DSP register double, single data transfer instructions (16 bit length)
2. Parallel processing instructions processed by the DSP unit (32 bit length)

Figure 2.12 shows each of the instruction formats.

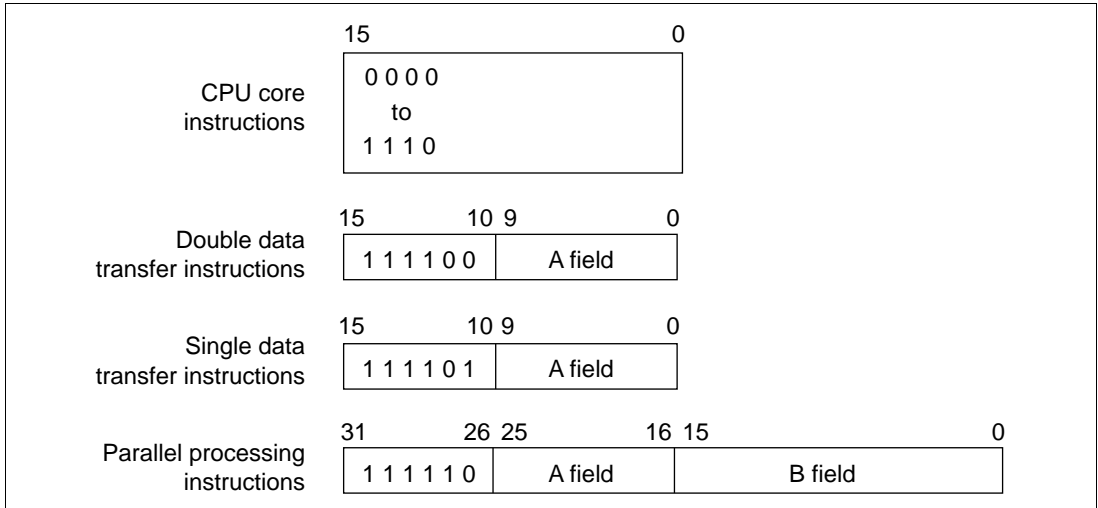

Figure 2.12 Instruction Formats for DSP Instructions

Double, Single Data Transfer Instructions: Table 2.15 indicates the data formats for double data transfer instructions, and table 2.16 indicates the data formats for single data transfer instructions.

Table 2.15 Instruction Formats for Double Data Transfers

Category	Mnemonic	15	14	13	12	11	10	9	8
X memory data transfers	NOPX	1	1	1	1	0	0	0	
	MOVX.W @Ax, Dx							Ax	
	MOVX.W @Ax+, Dx								
	MOVX.W @Ax+Ix, Dx								
	MOVX.W Da, @Ax								
	MOVX.W Da, @Ax+								
	MOVX.W Da, @Ax+Ix								
Y memory data transfers	NOPY	1	1	1	1	0	0		0
	MOVY.W @Ay, Dy								Ay
	MOVY.W @Ay+, Dy								
	MOVY.W @Ay+Iy, Dy								
	MOVY.W Da, @Ay								
	MOVY.W Da, @Ay+								
	MOVY.W Da, @Ay+Iy								

Table 2.15 Instruction Formats for Double Data Transfers (cont)

Category	Mnemonic	7	6	5	4	3	2	1	0
X memory data transfers	NOPX	0		0		0	0		
	MOVX.W @Ax, Dx	Dx		0		0	1		
	MOVX.W @Ax+, Dx					1	0		
	MOVX.W @Ax+Ix, Dx					1	1		
	MOVX.W Da, @Ax	Da		1		0	1		
	MOVX.W Da, @Ax+					1	0		
	MOVX.W Da, @Ax+Ix					1	1		
Y memory data transfers	NOPY		0		0			0	0
	MOVY.W @Ay, Dy		Dy		0			0	1
	MOVY.W @Ay+, Dy							1	0
	MOVY.W @Ay+Iy, Dy							1	1
	MOVY.W Da, @Ay		Da		1			0	1
	MOVY.W Da, @Ay+							1	0
	MOVY.W Da, @Ay+Iy							1	1

Ax: 0=R4, 1=R5 Ay: 0=R6, 1=R7 Dx: 0=X0, 1=X1 Dy: 0=Y0, 1=Y1 Da: 0=A0, 1=A1

Table 2.16 Instruction Formats for Single Data Transfers

Category	Mnemonic	15	14	13	12	11	10	9	8
Single data transfer	MOVS.W @-As, Ds	1	1	1	1	0	1		As
	MOVS.W @As, Ds								0: R4
	MOVS.W @As+, Ds								1: R5
	MOVS.W @As+Is, Ds								2: R2
	MOVS.W Ds, @-As								3: R3
	MOVS.W Ds, @As								
	MOVS.W Ds, @As+								
	MOVS.W Ds, @As+Is								
	MOVS.L @-As, Ds								
	MOVS.L @As, Ds								
	MOVS.L @As+, Ds								
	MOVS.L @As+Is, Ds								
	MOVS.L Ds, @-As								
	MOVS.L Ds, @As								
	MOVS.L Ds, @As+								
	MOVS.L Ds, @As+Is								

Table 2.16 Instruction Formats for Single Data Transfers (cont)

Category	Mnemonic	7	6	5	4	3	2	1	0
Single data transfer	MOVS.W @-As, Ds		Ds		0: (*)	0	0	0	0
	MOVS.W @As, Ds				1: (*)	0	1		
	MOVS.W @As+, Ds				2: (*)	1	0		
	MOVS.W @As+Is, Ds				3: (*)	1	1		
	MOVS.W Ds, @-As				4: (*)	0	0		1
	MOVS.W Ds, @As				5: A1	0	1		
	MOVS.W Ds, @As+				6: (*)	1	0		
	MOVS.W Ds, @As+Is				7: A0	1	1		
	MOVS.L @-As, Ds				8: X0	0	0	1	0
	MOVS.L @As, Ds				9: X1	0	1		
	MOVS.L @As+, Ds				A: Y0	1	0		
	MOVS.L @As+Is, Ds				B: Y1	1	1		
	MOVS.L Ds, @-As				C: M0	0	0		1
	MOVS.L Ds, @As				D: A1G	0	1		
	MOVS.L Ds, @As+				E: M1	1	0		
	MOVS.L Ds, @As+Is				F: A0G	1	1		

Note: * System reserved code

Parallel Processing Instructions: The parallel processing instructions allow for more efficient execution of digital signal processing using the DSP unit. They are 32 bit length, allowing simultaneously in parallel four processes, ALU operations, multiplications or 2 data transfers.

The parallel processing instructions are divided into A fields and B fields. The A field defines data transfer instructions; the B field defines ALU operation instructions and multiplication instructions. These instructions can be defined independently, the processes can be independent, and furthermore, they can be executed simultaneously in parallel. Table 2.17 indicates the A field parallel data transfer instructions, and table 2.18 indicates the B field ALU operation instructions and multiplication instructions. A fields instruction is the same as double data transfers in table 2.15.

Table 2.17 A Field Parallel Data Transfer Instructions

Category	Mnemonic	31	30	29	28	27	26	25	24	23
X memory data transfers	NOPX	1	1	1	1	1	0	0		0
	MOVX.W @Ax, Dx							Ax		Dx
	MOVX.W @Ax+, Dx									
	MOVX.W @Ax+Ix, Dx									
	MOVX.W Da, @Ax									Da
	MOVX.W Da, @Ax+									
	MOVX.W Da, @Ax+Ix									
Y memory data transfers	NOPY								0	
	MOVY.W @Ay, Dy								Ay	
	MOVY.W @Ay+, Dy									
	MOVY.W @Ay+Iy, Dy									
	MOVY.W Da, @Ay									
	MOVY.W Da, @Ay+									
	MOVY.W Da, @Ay+Iy									

Table 2.17 A Field Parallel Data Transfer Instructions (cont)

Category	Mnemonic	22	21	20	19	18	17	16	15–0
X memory data transfers	NOPX		0		0	0			B field
	MOVX.W @Ax, Dx		0		0	1			
	MOVX.W @Ax+, Dx				1	0			
	MOVX.W @Ax+Ix, Dx				1	1			
	MOVX.W Da, @Ax		1		0	1			
	MOVX.W Da, @Ax+				1	0			
	MOVX.W Da, @Ax+Ix				1	1			
Y memory data transfers	NOPY	0		0			0	0	
	MOVY.W @Ay, Dy	Dy		0			0	1	
	MOVY.W @Ay+, Dy						1	0	
	MOVY.W @Ay+Iy, Dy						1	1	
	MOVY.W Da, @Ay	Da		1			0	1	
	MOVY.W Da, @Ay+						1	0	
	MOVY.W Da, @Ay+Iy						1	1	

Ax: 0=R4, 1=R5 Ay: 0=R6, 1=R7 Dx: 0=X0, 1=X1 Dy: 0=Y0, 1=Y1 Da: 0=A0, 1=A1

Table 2.18 B Field ALU Operation Instructions, Multiplication Instructions (cont)

Category	Mnemonic	31-27	26	25-16	15	14	13	12	11	10	9	8	7	6	5	4	3	2	1	0	
Conditional three operand instructions	(if cc) PSHL Sx, Sy, Dz	1	0	A field	---	0	0	0	0	if cc											
	(if cc) PSHA Sx, Sy, Dz				---	0	1														
	(if cc) PSUB Sx, Sy, Dz				---	1	0														
	(if cc) PADD Sx, Sy, Dz				---	1	1														
	Reserved				---	0	0		0	1	01: Uncondition										
	(if cc) PAND Sx, Sy, Dz				---	0	1														
	(if cc) PXOR Sx, Sy, Dz				---	1	0														
	(if cc) POR Sx, Sy, Dz				---	1	1														
	(if cc) PDEC Sx, Dz				---	0	0		1	0	10:DCT										
	(if cc) PINC Sx, Dz				---	0	1														
	(if cc) PDEC Sy, Dz				---	1	0														
	(if cc) PINC Sy, Dz				---	1	1														
	(if cc) PCLR Dz				---	0	0		1	1	11:DCF										
	(if cc) PDMSB Sx, Dz				---	0	1														
	Reserved				---	1	0														
	(if cc) PDMSB Sy, Dz				---	1	1														
	(if cc) PNEG Sx, Dz				---	1	1	0	0	1	0										
	(if cc) PCOPY Sx, Dz				---		0	1													
	(if cc) PNEG Sy, Dz				---		1	0													
	(if cc) PCOPY Sy, Dz				---		1	1													
	Reserved				---						0	0									
	(if cc) PSTS MACH, Dz				---		0	0		1	1	if cc									
	(if cc) PSTS MACL, Dz				---		0	1													
	(if cc) PLDS Dz, MACH				---		1	0													
	(if cc) PLDS Dz, MACL				---		1	1													
	Reserved ^{*2}				---						0	0									
	Reserved		1		---						0	*									

* : Don't care

Notes: *1 System reserved code

*2 (if cc): DCT (DC bit true), DCF (DC bit false), or none (unconditional instruction)

2.5 Instruction Set

The instructions are divided into three groups: CPU instructions executed by the CPU core, DSP data transfer instructions executed by the DSP unit, and DSP operation instructions. There are a number of CPU instructions for supporting the DSP functions. The instruction set is explained below in terms of each of the three groups.

2.5.1 CPU Instruction Set

Table 2.19 lists the CPU instructions by classification.

Table 2.19 Classification of CPU Instructions

Classification	Types	Operation		No. of Instructions
		Code	Function	
Data transfer	5	MOV	Data transfer, immediate data transfer, peripheral module data transfer, structure data transfer	39
		MOVA	Effective address transfer	
		MOVT	T bit transfer	
		SWAP	Swap of upper and lower bytes	
		XTRCT	Extraction of the middle of registers connected	
Arithmetic operations	21	ADD	Binary addition	33
		ADDC	Binary addition with carry	
		ADDV	Binary addition with overflow	
		CMP/cond	Comparison	
		DIV1	Division	
		DIV0S	Initialization of signed division	
		DIV0U	Initialization of unsigned division	
		DMULS	Signed double-length multiplication	
		DMULU	Unsigned double-length multiplication	
		DT	Decrement and test	
		EXTS	Sign extension	
		EXTU	Zero extension	
		MAC	Multiply/accumulate, double-length multiply/accumulate operation	
		MUL	Double-length multiply operation	
		MULS	Signed multiplication	
		MULU	Unsigned multiplication	
		NEG	Negation	
		NEGC	Negation with borrow	
		SUB	Binary subtraction	
		SUBC	Binary subtraction with borrow	
SUBV	Binary subtraction with underflow			

Table 2.19 Classification of CPU Instructions (cont)

Classification	Types	Operation		No. of Instructions
		Code	Function	
Logic operations	6	AND	Logical AND	14
		NOT	Bit inversion	
		OR	Logical OR	
		TAS	Memory test and bit set	
		TST	Logical AND and T bit set	
		XOR	Exclusive OR	
Shift	10	ROTCL	One-bit left rotation with T bit	14
		ROTCR	One-bit right rotation with T bit	
		ROTL	One-bit left rotation	
		ROTR	One-bit right rotation	
		SHAL	One-bit arithmetic left shift	
		SHAR	One-bit arithmetic right shift	
		SHLL	One-bit logical left shift	
		SHLLn	n-bit logical left shift	
		SHLR	One-bit logical right shift	
		SHLRn	n-bit logical right shift	
Branch	9	BF	Conditional branch, conditional branch with delay (Branch when T = 0)	11
		BT	Conditional branch, conditional branch with delay (Branch when T = 1)	
		BRA	Unconditional branch	
		BRAF	Unconditional branch	
		BSR	Branch to subroutine procedure	
		BSRF	Branch to subroutine procedure	
		JMP	Unconditional branch	
		JSR	Branch to subroutine procedure	
		RTS	Return from subroutine procedure	

Table 2.19 Classification of CPU Instructions (cont)

Classification	Types	Operation		No. of Instructions
		Code	Function	
System control	14	CLRMAC	MAC register clear	71
		CLRT	T bit clear	
		LDC	Load to control register	
		LDRE	Load to repeat end register	
		LDRS	Load to repeat start register	
		LDS	Load to system register	
		NOP	No operation	
		RTE	Return from exception processing	
		SETRC	Repeat count setting	
		SETT	T bit set	
		SLEEP	Shift into power-down mode	
		STC	Storing control register data	
		STS	Storing system register data	
TRAPA	Trap exception handling			
Total:65				182

The instruction codes, operation, and execution states of the CPU instructions are listed by classification with the formats listed in below.

Instruction	Instruction Code	Operation	Execution Cycles	T Bit
Indicated by mnemonic	Indicated in MSB ↔ LSB order	Indicates summary of operation	Value when no wait states are inserted*1	Value of T bit after instruction is executed
Explanation of Symbols	Explanation of Symbols	Explanation of Symbols		
OP.Sz SRC, DEST	mmmm: Source register	→, ←: Transfer direction		Explanation of Symbols
OP: Operation code	nxxx: Destination register	(xx): Memory operand		
Sz: Size	0000: R0	M/Q/T: Flag bits in the SR		—: No change
SRC: Source	0001: R1	&: Logical AND of each bit		
DEST: Destination	: Logical OR of each bit		
Rm: Source register	1111: R15	^: Exclusive OR of each bit		
Rn: Destination register	iiii: Immediate data	~: Logical NOT of each bit		
imm: Immediate data	dddd: Displacement	<<n: n-bit left shift		
disp: Displacement*2		>>n: n-bit right shift		

Notes: *1 Instruction execution cycles: The execution cycles shown in the table are minimums. The actual number of cycles may be increased when (1) contention occurs between instruction fetches and data access, or (2) when the destination register of the load instruction (memory → register) and the register used by the next instruction are the same.

*2 Depending on the instruction's operand size, scaling is ×1, ×2, or ×4. For details, see the *SH-1/SH-2/SH-DSP Programming Manual*.

Table 2.20 Data Transfer Instructions

Instruction	Instruction Code	Operation	Cycles	T Bit
MOV #imm,Rn	1110nnnniiiiiii	imm → Sign extension → Rn	1	—
MOV.W @(disp,PC),Rn	1001nnnnnddddddd	(disp × 2 + PC) → Sign extension → Rn	1	—
MOV.L @(disp,PC),Rn	1101nnnnnddddddd	(disp × 4 + PC) → Rn	1	—
MOV Rm,Rn	0110nnnnnnmm0011	Rm → Rn	1	—
MOV.B Rm,@Rn	0010nnnnnnmm0000	Rm → (Rn)	1	—
MOV.W Rm,@Rn	0010nnnnnnmm0001	Rm → (Rn)	1	—
MOV.L Rm,@Rn	0010nnnnnnmm0010	Rm → (Rn)	1	—
MOV.B @Rm,Rn	0110nnnnnnmm0000	(Rm) → Sign extension → Rn	1	—
MOV.W @Rm,Rn	0110nnnnnnmm0001	(Rm) → Sign extension → Rn	1	—
MOV.L @Rm,Rn	0110nnnnnnmm0010	(Rm) → Rn	1	—
MOV.B Rm,@-Rn	0010nnnnnnmm0100	Rn-1 → Rn, Rm → (Rn)	1	—
MOV.W Rm,@-Rn	0010nnnnnnmm0101	Rn-2 → Rn, Rm → (Rn)	1	—
MOV.L Rm,@-Rn	0010nnnnnnmm0110	Rn-4 → Rn, Rm → (Rn)	1	—
MOV.B @Rm+,Rn	0110nnnnnnmm0100	(Rm) → Sign extension → Rn, Rm + 1 → Rm	1	—
MOV.W @Rm+,Rn	0110nnnnnnmm0101	(Rm) → Sign extension → Rn, Rm + 2 → Rm	1	—
MOV.L @Rm+,Rn	0110nnnnnnmm0110	(Rm) → Rn, Rm + 4 → Rm	1	—
MOV.B R0,@(disp,Rn)	10000000nnnnndddd	R0 → (disp + Rn)	1	—
MOV.W R0,@(disp,Rn)	10000001nnnnndddd	R0 → (disp × 2 + Rn)	1	—
MOV.L Rm,@(disp,Rn)	0001nnnnnnmmddddd	Rm → (disp × 4 + Rn)	1	—
MOV.B @(disp,Rm),R0	10000100nnnnndddd	(disp + Rm) → Sign extension → R0	1	—
MOV.W @(disp,Rm),R0	10000101nnnnndddd	(disp × 2 + Rm) → Sign extension → R0	1	—
MOV.L @(disp,Rm),Rn	0101nnnnnnmmddddd	(disp × 4 + Rm) → Rn	1	—
MOV.B Rm,@(R0,Rn)	0000nnnnnnmm0100	Rm → (R0 + Rn)	1	—
MOV.W Rm,@(R0,Rn)	0000nnnnnnmm0101	Rm → (R0 + Rn)	1	—

Table 2.20 Data Transfer Instructions (cont)

Instruction	Instruction Code	Operation	Cycles	T Bit
MOV.L Rm,@(R0,Rn)	0000nnnnmmmm0110	Rm → (R0 + Rn)	1	—
MOV.B @(R0,Rm),Rn	0000nnnnmmmm1100	(R0 + Rm) → Sign extension → Rn	1	—
MOV.W @(R0,Rm),Rn	0000nnnnmmmm1101	(R0 + Rm) → Sign extension → Rn	1	—
MOV.L @(R0,Rm),Rn	0000nnnnmmmm1110	(R0 + Rm) → Rn	1	—
MOV.B R0,@(disp,GBR)	11000000dddddddd	R0 → (disp + GBR)	1	—
MOV.W R0,@(disp,GBR)	11000001dddddddd	R0 → (disp × 2 + GBR)	1	—
MOV.L R0,@(disp,GBR)	11000010dddddddd	R0 → (disp × 4 + GBR)	1	—
MOV.B @(disp,GBR),R0	11000100dddddddd	(disp + GBR) → Sign extension → R0	1	—
MOV.W @(disp,GBR),R0	11000101dddddddd	(disp × 2 + GBR) → Sign extension → R0	1	—
MOV.L @(disp,GBR),R0	11000110dddddddd	(disp × 4 + GBR) → R0	1	—
MOVA @(disp,PC),R0	11000111dddddddd	disp × 4 + PC → R0	1	—
MOVT Rn	0000nnnn00101001	T → Rn	1	—
SWAP.B Rm,Rn	0110nnnnmmmm1000	Rm → Swap the bottom two bytes → Rn	1	—
SWAP.W Rm,Rn	0110nnnnmmmm1001	Rm → Swap upper and lower words → Rn	1	—
XTRCT Rm,Rn	0010nnnnmmmm1101	Rm: Middle 32 bits of Rn → Rn	1	—

Table 2.21 Arithmetic Instructions

Instruction		Instruction Code	Operation	Cycles	T Bit
ADD	Rm, Rn	0011nnnnmmmm1100	$Rn + Rm \rightarrow Rn$	1	—
ADD	#imm, Rn	0111nnnniiiiiii	$Rn + imm \rightarrow Rn$	1	—
ADDC	Rm, Rn	0011nnnnmmmm1110	$Rn + Rm + T \rightarrow Rn$, Carry $\rightarrow T$	1	Carry
ADDV	Rm, Rn	0011nnnnmmmm1111	$Rn + Rm \rightarrow Rn$, Overflow $\rightarrow T$	1	Overflow
CMP/EQ	#imm, R0	10001000iiiiiii	If $R0 = imm$, $1 \rightarrow T$	1	Comparison result
CMP/EQ	Rm, Rn	0011nnnnmmmm0000	If $Rn = Rm$, $1 \rightarrow T$	1	Comparison result
CMP/HS	Rm, Rn	0011nnnnmmmm0010	If $Rn \geq Rm$ with unsigned data, $1 \rightarrow T$	1	Comparison result
CMP/GE	Rm, Rn	0011nnnnmmmm0011	If $Rn \geq Rm$ with signed data, $1 \rightarrow T$	1	Comparison result
CMP/HI	Rm, Rn	0011nnnnmmmm0110	If $Rn > Rm$ with unsigned data, $1 \rightarrow T$	1	Comparison result
CMP/GT	Rm, Rn	0011nnnnmmmm0111	If $Rn > Rm$ with signed data, $1 \rightarrow T$	1	Comparison result
CMP/PL	Rn	0100nnnn00010101	If $Rn > 0$, $1 \rightarrow T$	1	Comparison result
CMP/PZ	Rn	0100nnnn00010001	If $Rn \geq 0$, $1 \rightarrow T$	1	Comparison result
CMP/STR	Rm, Rn	0010nnnnmmmm1100	If Rn and Rm contain an identical byte, $1 \rightarrow T$	1	Comparison result
DIV1	Rm, Rn	0011nnnnmmmm0100	Single-step division (Rn/Rm)	1	Calculation result
DIV0S	Rm, Rn	0010nnnnmmmm0111	MSB of Rn $\rightarrow Q$, MSB of Rm $\rightarrow M$, $M \wedge Q \rightarrow T$	1	Calculation result
DIV0U		000000000011001	$0 \rightarrow M/Q/T$	1	0

Table 2.21 Arithmetic Instructions (cont)

Instruction	Instruction Code	Operation	Cycles	T Bit
DMULS.L Rm, Rn	0011nnnnmmmm1101	Signed operation of $Rn \times Rm \rightarrow MACH, MACL$ $32 \times 32 \rightarrow 64$ bits	2 to 4*	—
DMULU.L Rm, Rn	0011nnnnmmmm0101	Unsigned operation of $Rn \times Rm \rightarrow MACH, MACL$ $32 \times 32 \rightarrow 64$ bits	2 to 4*	—
DT Rn	0100nnnn00010000	$Rn - 1 \rightarrow Rn$, when Rn is 0, $1 \rightarrow T$ When Rn is nonzero, $0 \rightarrow T$	1	Comparison result
EXTS.B Rm, Rn	0110nnnnmmmm1110	A byte in Rm is sign-extended $\rightarrow Rn$	1	—
EXTS.W Rm, Rn	0110nnnnmmmm1111	A word in Rm is sign-extended $\rightarrow Rn$	1	—
EXTU.B Rm, Rn	0110nnnnmmmm1100	A byte in Rm is zero-extended $\rightarrow Rn$	1	—
EXTU.W Rm, Rn	0110nnnnmmmm1101	A word in Rm is zero-extended $\rightarrow Rn$	1	—
MAC.L @Rm+, @Rn+	0000nnnnmmmm1111	Signed operation of $(Rn) \times (Rm) + MAC \rightarrow MAC$ $32 \times 32 + 64 \rightarrow 64$ bits	$3/(2 \text{ to } 4)^*$	—
MAC.W @Rm+, @Rn+	0100nnnnmmmm1111	Signed operation of $(Rn) \times (Rm) + MAC \rightarrow MAC$ $16 \times 16 + 64 \rightarrow 64$ bits	$3/(2)^*$	—
MUL.L Rm, Rn	0000nnnnmmmm0111	$Rn \times Rm \rightarrow MACL, 32 \times 32 \rightarrow 32$ bits	2 to 4*	—
MULS.W Rm, Rn	0010nnnnmmmm1111	Signed operation of $Rn \times Rm \rightarrow MAC$ $16 \times 16 \rightarrow 32$ bits	1 to 3*	—
MULU.W Rm, Rn	0010nnnnmmmm1110	Unsigned operation of $Rn \times Rm \rightarrow MAC$ $16 \times 16 \rightarrow 32$ bits	1 to 3*	—
NEG Rm, Rn	0110nnnnmmmm1011	$0 - Rm \rightarrow Rn$	1	—
NEGC Rm, Rn	0110nnnnmmmm1010	$0 - Rm - T \rightarrow Rn$, Borrow $\rightarrow T$	1	Borrow

Table 2.21 Arithmetic Instructions (cont)

Instruction	Instruction Code	Operation	Cycles	T Bit
SUB Rm, Rn	0011nnnnmmmm1000	$Rn - Rm \rightarrow Rn$	1	—
SUBC Rm, Rn	0011nnnnmmmm1010	$Rn - Rm - T \rightarrow Rn$, Borrow $\rightarrow T$	1	Borrow
SUBV Rm, Rn	0011nnnnmmmm1011	$Rn - Rm \rightarrow Rn$, Underflow $\rightarrow T$	1	Underflow

Note: * The normal number of execution cycles. The number in parentheses is the number of execution cycles in the case of contention with preceding or following instructions.

Table 2.22 Logic Operation Instructions

Instruction	Instruction Code	Operation	Cycles	T Bit
AND Rm, Rn	0010nnnnmmmm1001	$Rn \& Rm \rightarrow Rn$	1	—
AND #imm, R0	11001001iiiiiii	$R0 \& imm \rightarrow R0$	1	—
AND.B #imm, @(R0, GBR)	11001101iiiiiii	$(R0 + GBR) \& imm \rightarrow$ $(R0 + GBR)$	3	—
NOT Rm, Rn	0110nnnnmmmm0111	$\sim Rm \rightarrow Rn$	1	—
OR Rm, Rn	0010nnnnmmmm1011	$Rn Rm \rightarrow Rn$	1	—
OR #imm, R0	11001011iiiiiii	$R0 imm \rightarrow R0$	1	—
OR.B #imm, @(R0, GBR)	11001111iiiiiii	$(R0 + GBR) imm \rightarrow$ $(R0 + GBR)$	3	—
TAS.B @Rn	0100nmmn00011011	If (Rn) is 0, $1 \rightarrow T$, $1 \rightarrow$ MSB of (Rn)	4	Test result
TST Rm, Rn	0010nnnnmmmm1000	$Rn \& Rm$, if the result is $0, 1 \rightarrow T$	1	Test result
TST #imm, R0	11001000iiiiiii	$R0 \& imm$, if the result is $0, 1 \rightarrow T$	1	Test result
TST.B #imm, @(R0, GBR)	11001100iiiiiii	$(R0 + GBR) \& imm$, if the result is $0, 1 \rightarrow T$	3	Test result
XOR Rm, Rn	0010nnnnmmmm1010	$Rn \wedge Rm \rightarrow Rn$	1	—
XOR #imm, R0	11001010iiiiiii	$R0 \wedge imm \rightarrow R0$	1	—
XOR.B #imm, @(R0, GBR)	11001110iiiiiii	$(R0 + GBR) \wedge imm \rightarrow$ $(R0 + GBR)$	3	—

Table 2.23 Shift Instructions

Instruction		Instruction Code	Operation	Cycles	T Bit
ROTL	Rn	0100nnnn00000100	$T \leftarrow Rn \leftarrow MSB$	1	MSB
ROTR	Rn	0100nnnn00000101	$LSB \rightarrow Rn \rightarrow T$	1	LSB
ROTCL	Rn	0100nnnn00100100	$T \leftarrow Rn \leftarrow T$	1	MSB
ROTCR	Rn	0100nnnn00100101	$T \rightarrow Rn \rightarrow T$	1	LSB
SHAL	Rn	0100nnnn00100000	$T \leftarrow Rn \leftarrow 0$	1	MSB
SHAR	Rn	0100nnnn00100001	$MSB \rightarrow Rn \rightarrow T$	1	LSB
SHLL	Rn	0100nnnn00000000	$T \leftarrow Rn \leftarrow 0$	1	MSB
SHLR	Rn	0100nnnn00000001	$0 \rightarrow Rn \rightarrow T$	1	LSB
SHLL2	Rn	0100nnnn00001000	$Rn \ll 2 \rightarrow Rn$	1	—
SHLR2	Rn	0100nnnn00001001	$Rn \gg 2 \rightarrow Rn$	1	—
SHLL8	Rn	0100nnnn00011000	$Rn \ll 8 \rightarrow Rn$	1	—
SHLR8	Rn	0100nnnn00011001	$Rn \gg 8 \rightarrow Rn$	1	—
SHLL16	Rn	0100nnnn00101000	$Rn \ll 16 \rightarrow Rn$	1	—
SHLR16	Rn	0100nnnn00101001	$Rn \gg 16 \rightarrow Rn$	1	—

Table 2.24 Branch Instructions

Instruction	Instruction Code	Operation	Cycles	T Bit	
BF	label	100010111ddddddd	If T = 0, disp × 2 + PC → PC, if T = 1, nop	3/1*	—
BF/S	label	100011111ddddddd	Delayed branch, if T = 0, disp × 2 + PC → PC, if T = 1, nop	2/1*	—
BT	label	100010011ddddddd	If T = 1, disp × 2 + PC → PC, if T = 0, nop	3/1*	—
BT/S	label	100011011ddddddd	Delayed branch, if T = 1, disp × 2 + PC → PC, if T = 0, nop	2/1*	—
BRA	label	1010ddddddddddd	Delayed branch, disp × 2 + PC → PC	2	—
BRAF	Rm	0000mmmm00100011	Delayed branch, Rm + PC → PC	2	—
BSR	label	1011ddddddddddd	Delayed branch, PC → PR, disp × 2 + PC → PC	2	—
BSRF	Rm	0000mmmm00000011	Delayed branch, PC → PR, Rm + PC → PC	2	—
JMP	@Rm	0100mmmm00101011	Delayed branch, Rm → PC	2	—
JSR	@Rm	0100mmmm00001011	Delayed branch, PC → PR, Rm → PC	2	—
RTS		000000000001011	Delayed branch, PR → PC	2	—

Note: * One state when it does not branch.

Table 2.25 System Control Instructions

Instruction		Instruction Code	Operation	Cycles	T Bit
CLRMAC		000000000101000	0 → MACH, MACL	1	—
CLRT		000000000001000	0 → T	1	0
LDC	Rm, SR	0100mmmm00001110	Rm → SR	1	LSB
LDC	Rm, GBR	0100mmmm00011110	Rm → GBR	1	—
LDC	Rm, VBR	0100mmmm00101110	Rm → VBR	1	—
LDC	Rm, MOD	0100mmmm01011110	Rm → MOD	1	—
LDC	Rm, RE	0100mmmm01111110	Rm → RE	1	—
LDC	Rm, RS	0100mmmm01101110	Rm → RS	1	—
LDC.L	@Rm+, SR	0100mmmm00000111	(Rm) → SR, Rm + 4 → Rm	3	LSB
LDC.L	@Rm+, GBR	0100mmmm00010111	(Rm) → GBR, Rm + 4 → Rm	3	—
LDC.L	@Rm+, VBR	0100mmmm00100111	(Rm) → VBR, Rm + 4 → Rm	3	—
LDC.L	@Rm+, MOD	0100mmmm01010111	(Rm) → MOD, Rm + 4 → Rm	3	—
LDC.L	@Rm+, RE	0100mmmm01110111	(Rm) → RE, Rm + 4 → Rm	3	—
LDC.L	@Rm+, RS	0100mmmm01100111	(Rm) → RS, Rm + 4 → Rm	3	—
LDRE	@(disp, PC)	10001110ddddddd	disp × 2 + PC → RE	1	—
LDRS	@(disp, PC)	10001100ddddddd	disp × 2 + PC → RS	1	—
LDS	Rm, MACH	0100mmmm00001010	Rm → MACH	1	—
LDS	Rm, MACL	0100mmmm00011010	Rm → MACL	1	—
LDS	Rm, PR	0100mmmm00101010	Rm → PR	1	—
LDS	Rm, DSR	0100mmmm01101010	Rm → DSR	1	—
LDS	Rm, A0	0100mmmm01111010	Rm → A0	1	—
LDS	Rm, X0	0100mmmm10001010	Rm → X0	1	—
LDS	Rm, X1	0100mmmm10011010	Rm → X1	1	—
LDS	Rm, Y0	0100mmmm10101010	Rm → Y0	1	—
LDS	Rm, Y1	0100mmmm10111010	Rm → Y1	1	—
LDS.L	@Rm+, MACH	0100mmmm00000110	(Rm) → MACH, Rm + 4 → Rm	1	—
LDS.L	@Rm+, MACL	0100mmmm00010110	(Rm) → MACL, Rm + 4 → Rm	1	—
LDS.L	@Rm+, PR	0100mmmm00100110	(Rm) → PR, Rm + 4 → Rm	1	—

Table 2.25 System Control Instructions (cont)

Instruction	Instruction Code	Operation	Cycles	T Bit
LDS.L @Rm+, DSR	0100mmmm01100110	(Rm) → DSR, Rm + 4 → Rm	1	—
LDS.L @Rm+, A0	0100mmmm01110110	(Rm) → A0, Rm + 4 → Rm	1	—
LDS.L @Rm+, X0	0100mmmm10000110	(Rm) → X0, Rm + 4 → Rm	1	—
LDS.L @Rm+, X1	0100mmmm10010110	(Rm) → X1, Rm + 4 → Rm	1	—
LDS.L @Rm+, Y0	0100mmmm10100110	(Rm) → Y0, Rm + 4 → Rm	1	—
LDS.L @Rm+, Y1	0100mmmm10110110	(Rm) → Y1, Rm + 4 → Rm	1	—
NOP	000000000001001	No operation	1	—
RTE	000000000101011	Delayed branch, stack area → PC/SR	4	LSB
SETRC Rm	0100mmmm00010100	RE–RS operation result (repeat status) → RF1, RF0 Rm[11:0] → RC (SR[27:16])	1	—
SETRC #imm	1000010iiiiiii	RE–RS operation result (repeat status) → RF1, RF0 imm → RC (SR[23:16]), 0 → SR[27:24]	1	1
SETT	000000000011000	1 → T	1	1
SLEEP	000000000011011	Sleep	3*	—
STC SR, Rn	0000nnnn00000010	SR → Rn	1	—
STC GBR, Rn	0000nnnn00010010	GBR → Rn	1	—
STC VBR, Rn	0000nnnn00100010	VBR → Rn	1	—
STC MOD, Rn	0000nnnn01010010	MOD → Rn	1	—
STC RE, Rn	0000nnnn01110010	RE → Rn	1	—
STC RS, Rn	0000nnnn01100010	RS → Rn	1	—
STC.L SR, @-Rn	0100nnnn00000011	Rn–4 → Rn, SR → (Rn)	2	—
STC.L GBR, @-Rn	0100nnnn00010011	Rn–4 → Rn, GBR → (Rn)	2	—
STC.L VBR, @-Rn	0100nnnn00100011	Rn–4 → Rn, VBR → (Rn)	2	—
STC.L MOD, @-Rn	0100nnnn01010011	Rn–4 → Rn, MOD → (Rn)	2	—
STC.L RE, @-Rn	0100nnnn01110011	Rn–4 → Rn, RE → (Rn)	2	—
STC.L RS, @-Rn	0100nnnn01100011	Rn–4 → Rn, RS → (Rn)	2	—

Table 2.25 System Control Instructions (cont)

Instruction		Instruction Code	Operation	Cycles	T Bit
STS	MACH, Rn	0000nnnn00001010	MACH → Rn	1	—
STS	MACL, Rn	0000nnnn00011010	MACL → Rn	1	—
STS	PR, Rn	0000nnnn00101010	PR → Rn	1	—
STS	DSR, Rn	0000nnnn01101010	DSR → Rn	1	—
STS	A0, Rn	0000nnnn01111010	A0 → Rn	1	—
STS	X0, Rn	0000nnnn10001010	X0 → Rn	1	—
STS	X1, Rn	0000nnnn10011010	X1 → Rn	1	—
STS	Y0, Rn	0000nnnn10101010	Y0 → Rn	1	—
STS	Y1, Rn	0000nnnn10111010	Y1 → Rn	1	—
STS.L	MACH, @-Rn	0100nnnn00000010	Rn-4 → Rn, MACH → (Rn)	1	—
STS.L	MACL, @-Rn	0100nnnn00010010	Rn-4 → Rn, MACL → (Rn)	1	—
STS.L	PR, @-Rn	0100nnnn00100010	Rn-4 → Rn, PR → (Rn)	1	—
STS.L	DSR, @-Rn	0100nnnn01100010	Rn-4 → Rn, DSR → (Rn)	1	—
STS.L	A0, @-Rn	0100nnnn01110010	Rn-4 → Rn, A0 → (Rn)	1	—
STS.L	X0, @-Rn	0100nnnn10000010	Rn-4 → Rn, X0 → (Rn)	1	—
STS.L	X1, @-Rn	0100nnnn10010010	Rn-4 → Rn, X1 → (Rn)	1	—
STS.L	Y0, @-Rn	0100nnnn10100010	Rn-4 → Rn, Y0 → (Rn)	1	—
STS.L	Y1, @-Rn	0100nnnn10110010	Rn-4 → Rn, Y1 → (Rn)	1	—
TRAPA	#imm	11000011iiiiiii	PC/SR → stack area, (imm × 4 + VBR) → PC	8	—

Note: * The number of execution cycles before the chip enters sleep mode.

Precautions Concerning the Number of Instruction Execution Cycles: The execution cycles listed in the tables are minimum values. In practice, the number of execution cycles increases under such conditions as 1) when the instruction fetch is in contention with a data access, 2) when the destination register of a load instruction (memory → register) is the same as the register used by the next instruction, 3) when the branch destination address of a branch instruction is a $4n + 2$ address.

CPU Instructions That Support DSP Functions: A number of system control instructions have been added to the CPU core instructions to support DSP functions. The RS, RE and MOD registers have been added to support repeat control and modulo addressing, and the repeat counter (RC) has been added to the status register (SR). The LDC and STC instructions have been added in order to access the aforementioned. The LDS and STS instructions have been added in order to access the DSP registers DSR, A0, X0, X1, Y0 and Y1.

The SETRC instruction has been added to set the repeat counter (RC, bits 27 to 16) and repeat flags (RF1, RF0, bits 3 and 2) of the SR register. When the SETRC instruction operand is immediate, the 8-bit immediate data is stored in bits 23 to 16 of the SR register and bits 27 to 24 are cleared to 0. When the operand is a register, bits 11 to 0 (12 bits) of the register are stored in bits 27 to 16 of the SR register. Additionally, the status of 1 instruction repeat (00), 2 instruction repeat (01), 3 instruction repeat (11) or 4 instruction or greater repeat (10) is set from the RS and RE set values.

In addition to the LDC instruction, the LDRS and LDRE instructions have been added for establishing the repeat start and repeat end addresses in the RS and RE registers.

The added instructions are listed in table 2.26.

Table 2.26 Added CPU Instructions

Instruction		Code	Operation	Cycles	T Bit
LDC	Rm, MOD	0100mmmm01011110	Rm→MOD	1	—
LDC	Rm, RE	0100mmmm01111110	Rm→RE	1	—
LDC	Rm, RS	0100mmmm01101110	Rm→RS	1	—
LDC.L	@Rm+, MOD	0100mmmm01010111	(Rm)→MOD, Rm+4→Rm	3	—
LDC.L	@Rm+, RE	0100mmmm01110111	(Rm)→RE, Rm+4→Rm	3	—
LDC.L	@Rm+, RS	0100mmmm01100111	(Rm)→RS, Rm+4→Rm	3	—
STC	MOD, Rn	0000nnnn01010010	MOD→Rn	1	—
STC	RE, Rn	0000nnnn01110010	RE→Rn	1	—
STC	RS, Rn	0000nnnn01100010	RS→Rn	1	—
STC.L	MOD, @-Rn	0100nnnn01010011	Rn-4→Rn, MOD→(Rn)	2	—
STC.L	RE, @-Rn	0100nnnn01110011	Rn-4→Rn, RE→(Rn)	2	—
STC.L	RS, @-Rn	0100nnnn01100011	Rn-4→Rn, RS→(Rn)	2	—
LDS	Rm, DSR	0100mmmm01101010	Rm→DSR	1	—
LDS.L	@Rm+, DSR	0100mmmm01100110	(Rm)→DSR, Rm+4→Rm	1	—
LDS	Rm, A0	0100mmmm01111010	Rm→A0	1	—
LDS.L	@Rm+, A0	0100mmmm01110110	(Rm)→A0, Rm+4→Rm	1	—
LDS	Rm, X0	0100mmmm10001010	Rm→X0	1	—
LDS.L	@Rm+, X0	0100mmmm10000110	(Rm)→X0, Rm+4→Rm	1	—
LDS	Rm, X1	0100mmmm10011010	Rm→X1	1	—
LDS.L	@Rm+, X1	0100mmmm10010110	(Rm)→X1, Rm+4→Rm	1	—
LDS	Rm, Y0	0100mmmm10101010	Rm→Y0	1	—
LDS.L	@Rm+, Y0	0100mmmm10100110	(Rm)→Y0, Rm+4→Rm	1	—
LDS	Rm, Y1	0100mmmm10111010	Rm→Y1	1	—
LDS.L	@Rm+, Y1	0100mmmm10110110	(Rm)→Y1, Rm+4→Rm	1	—
STS	DSR, Rn	0000nnnn01101010	DSR→Rn	1	—
STS.L	DSR, @-Rn	0100nnnn01100010	Rn-4→Rn, DSR→(Rn)	1	—
STS	A0, Rn	0000nnnn01111010	A0→Rn	1	—
STS.L	A0, @-Rn	0100nnnn01110010	Rn-4→Rn, A0→(Rn)	1	—
STS	X0, Rn	0000nnnn10001010	X0→Rn	1	—
STS.L	X0, @-Rn	0100nnnn10000010	Rn-4→Rn, X0→(Rn)	1	—
STS	X1, Rn	0000nnnn10011010	X1→Rn	1	—

Table 2.26 Added CPU Instructions (cont)

Instruction		Code	Operation	Cycles	T Bit
STS.L	X1, @-Rn	0100nmmn10010010	Rn-4→Rn, X1→(Rn)	1	—
STS	Y0, Rn	0000nmmn10101010	Y0→Rn	1	—
STS.L	Y0, @-Rn	0100nmmn10100010	Rn-4→Rn, Y0→(Rn)	1	—
STS	Y1, Rn	0000nmmn10111010	Y1→Rn	1	—
STS.L	Y1, @-Rn	0100nmmn10110010	Rn-4→Rn, Y1→(Rn)	1	—
SETRC	Rm	0100mmmm00010100	Rm[11:0]→RC (SR[27:16])	1	—
SETRC	#imm	10000010iiiiiii	imm→RC(SR[23:16]), 0→SR[27:24]	1	—
LDRS	@(disp, PC)	10001100ddddddd	disp × 2+PC→RS	1	—
LDRE	@(disp, PC)	10001110ddddddd	disp × 2+PC→RE	1	—

2.5.2 DSP Data Transfer Instruction Set

Table 2.27 lists the DSP data transfer instructions by classification.

Table 2.27 Classification of DSP Data Transfer Instructions

Classification	Types	Operation Code	Function	No. of Instructions
Double data transfer instructions	4	NOPX	X memory no operation	14
		MOVX	X memory data transfer	
		NOPY	Y memory no operation	
		MOVY	Y memory data transfer	
Single data transfer instructions	1	MOVS	Single data transfer	16
Total: 5			Total: 30	

The data transfer instructions are divided into two groups, double data transfers and single data transfers. Double data transfers can be combined with DSP operation instructions to perform DSP parallel processing. The parallel processing instructions are 32 bit length, and the double data transfer instructions are incorporated into their A fields. Double data transfers that are not parallel processing instructions are 16 bit length, as are the single data transfer instructions.

The X memory and Y memory can be accessed simultaneously in parallel in double data transfers. One instruction each is designated from among the X and Y memory data accesses. The Ax

pointer is used to access X memory; the Ay pointer is used to access Y memory. Double data transfers can only access X, Y memory.

Single data transfers can be accessed from any area. Single data transfers use the Ax pointer and two other pointers as an As pointer.

Table 2.28 Double Data Transfer Instructions (X Memory Data)

Instruction	Operation	Code	Cycles	DC Bit
NOPX	No Operation	1111000*0*0*00**	1	—
MOVX.W @Ax, Dx	(Ax)→MSW of Dx,0→LSW of Dx	111100A*D*0*01**	1	—
MOVX.W @Ax+, Dx	(Ax)→MSW of Dx,0→LSW of Dx,Ax+2→Ax	111100A*D*0*10**	1	—
MOVX.W @Ax+Ix, Dx	(Ax)→MSW of Dx,0→LSW of Dx,Ax+Ix→Ax	111100A*D*0*11**	1	—
MOVX.W Da, @Ax	MSW of Da→(Ax)	111100A*D*1*01**	1	—
MOVX.W Da, @Ax+	MSW of Da→(Ax),Ax+2→Ax	111100A*D*1*10**	1	—
MOVX.W Da, @Ax+Ix	MSW of Da→(Ax),Ax+Ix→Ax	111100A*D*1*11**	1	—

Table 2.29 Double Data Transfer Instructions (Y Memory Data)

Instruction	Operation	Code	Cycles	DC Bit
NOFY	No Operation	111100*0*0*0**00	1	—
MOVY.W @Ay, Dy	(Ay)→MSW of Dy,0→LSW of Dy	111100*A*D*0**01	1	—
MOVY.W @Ay+, Dy	(Ay)→MSW of Dy,0→LSW of Dy, Ay+2→Ay	111100*A*D*0**10	1	—
MOVY.W @Ay+Iy, Dy	(Ay)→MSW of Dy,0→LSW of Dy, Ay+Iy→Ay	111100*A*D*0**11	1	—
MOVY.W Da, @Ay	MSW of Da→(Ay)	111100*A*D*1**01	1	—
MOVY.W Da, @Ay+	MSW of Da→(Ay),Ay+2→Ay	111100*A*D*1**10	1	—
MOVY.W Da, @Ay+Iy	MSW of Da→(Ay),Ay+Iy→Ay	111100*A*D*1**11	1	—

Table 2.30 Single Data Transfer Instructions

Instruction	Operation	Code	Cycles	DC Bit
MOVS.W @-As, Ds	As-2→As,(As)→MSW of Ds,0→LSW of Ds	111101AADDDD0000	1	—
MOVS.W @As, Ds	(As)→MSW of Ds,0→LSW of Ds	111101AADDDD0100	1	—
MOVS.W @As+, Ds	(As)→MSW of Ds,0→LSW of Ds, As+2→As	111101AADDDD1000	1	—
MOVS.W @As+Ix, Ds	(As)→MSW of Ds,0→LSW of Ds, As+Ix→As	111101AADDDD1100	1	—
MOVS.W Ds, @-As	As-2→As,MSW of Ds→(As)*	111101AADDDD0001	1	—
MOVS.W Ds, @As	MSW of Ds→(As)*	111101AADDDD0101	1	—
MOVS.W Ds, @As+	MSW of Ds→(As)*,As+2→As	111101AADDDD1001	1	—
MOVS.W Ds, @As+Is	MSW of Ds→(As)*,As+Is→As	111101AADDDD1101	1	—
MOVS.L @-As, Ds	As-4→As,(As)→Ds	111101AADDDD0010	1	—
MOVS.L @As, Ds	(As)→Ds	111101AADDDD0110	1	—
MOVS.L @As+, Ds	(As)→Ds,As+4→As	111101AADDDD1010	1	—
MOVS.L @As+Is, Ds	(As)→Ds,As+Is→As	111101AADDDD1110	1	—
MOVS.L Ds, @-As	As-4→As,Ds→(As)*	111101AADDDD0011	1	—
MOVS.L Ds, @As	Ds→(As)*	111101AADDDD0111	1	—
MOVS.L Ds, @As+	Ds→(As)*,As+4→As	111101AADDDD1011	1	—
MOVS.L Ds, @As+Is	Ds→(As)*,As+Is→As	111101AADDDD1111	1	—

Note: * When guard bit registers A0G and A1G are specified for the source operand Ds, data is sign-extended before being transferred.

Table 2.31 shows the correspondence between the DSP data transfer operands and registers. CPU core registers are used as pointer addresses indicating memory addresses.

Table 2.31 Correspondence between DSP Data Transfer Operands and Registers

SH (CPU Core) Registers

Oper- and	SH (CPU Core) Registers									
	R0	R1	R2 (As2)	R3 (As3)	R4 (Ax0) (As0)	R5 (Ax1) (As0)	R6 (Ay0)	R7 (Ay1)	R8 (Ix) (Is)	R9 (Iy)
Ax	—	—	—	—	Yes	Yes	—	—	—	—
Ix (Is)	—	—	—	—	—	—	—	—	Yes	—
Dx	—	—	—	—	—	—	—	—	—	—
Ay	—	—	—	—	—	—	Yes	Yes	—	—
Iy	—	—	—	—	—	—	—	—	—	Yes
Dy	—	—	—	—	—	—	—	—	—	—
Da	—	—	—	—	—	—	—	—	—	—
As	—	—	Yes	Yes	Yes	Yes	—	—	—	—
Ds	—	—	—	—	—	—	—	—	—	—

DSP Registers

Oper- and	DSP Registers									
	X0	X1	Y0	Y1	M0	M1	A0	A1	A0G	A1G
Ax	—	—	—	—	—	—	—	—	—	—
Ix (Is)	—	—	—	—	—	—	—	—	—	—
Dx	Yes	Yes	—	—	—	—	—	—	—	—
Ay	—	—	—	—	—	—	—	—	—	—
Iy	—	—	—	—	—	—	—	—	—	—
Dy	—	—	Yes	Yes	—	—	—	—	—	—
Da	—	—	—	—	—	—	Yes	Yes	—	—
As	—	—	—	—	—	—	—	—	—	—
Ds	Yes	Yes	Yes	Yes	Yes	Yes	Yes	Yes	Yes	Yes

Note: Yes indicates that the register can be set.

2.5.3 DSP Operation Instruction Set

DSP operation instructions are digital signal processing instructions processed by the DSP unit. These instructions use 32-bit instruction codes, and multiple instructions are executed in parallel. The instruction codes are divided into an A field and a B field; parallel data transfer instructions are designated in the A field, and single or double data operation instructions are designated in the B field. Instructions can be independently designated and execution can also be carried out independently. A parallel data transfer instruction designated in the A field is exactly the same as a double data transfer instruction.

The B field data operation instructions are divided into three groups: double data operation instructions, conditional single data operation instructions, and unconditional single data operation instructions. Table 2.32 lists the instruction formats of the DSP operation instructions. Each of the operands can be independently selected from the DSP registers. Table 2.33 shows the correspondence between the DSP operation instruction operands and registers.

Table 2.32 DSP Operation Instruction Formats

Classification		Instruction Forms	Instruction
Double data operation instructions (6 operands)		ALUop. Sx, Sy, Du	PADD PMULS,
		MLTop. Se, Sf, Dg	PSUB PMULS
Conditional single data operation instructions	3 operands	ALUop. Sx, Sy, Dz	PADD, PAND, POR,
		DCT ALUop. Sx, Sy, Dz	PSHA, PSHL, PSUB,
		DCF ALUop. Sx, Sy, Dz	PXOR
	2 operands	ALUop. Sx, Dz	PCOPY, PDEC, PDMSB,
		DCT ALUop. Sx, Dz	PINC, PLDS, PSTS,
		DCF ALUop. Sx, Dz	PNEG
		ALUop. Sy, Dz	
		DCT ALUop. Sy, Dz	
		DCF ALUop. Sy, Dz	
	1 operand	ALUop. Dz	PCLR, PSHA #imm,
		DCT ALUop. Dz	PSHL #imm
		DCF ALUop. Dz	
	Unconditional single data operation instructions	3 operands	ALUop. Sx, Sy, Du
MLTop. Se, Sf, Dg			
2 operands		ALUop. Sx, Dz	PCMP, PABS, PRND
		ALUop. Sy, Dz	
		ALUop. Sx, Sy	
1 operand		ALUop. Dz	PSHA #imm, PSHL #imm

Table 2.33 Correspondence between DSP Instruction Operands and Registers

Register	ALU and BPU Instructions				Multiplication Instructions		
	Sx	Sy	Dz	Du	Se	Sf	Dg
A0	Yes	—	Yes	Yes	—	—	Yes
A1	Yes	—	Yes	Yes	Yes	Yes	Yes
M0	—	Yes	Yes	—	—	—	Yes
M1	—	Yes	Yes	—	—	—	Yes
X0	Yes	—	Yes	Yes	Yes	Yes	—
X1	Yes	—	Yes	—	Yes	—	—
Y0	—	Yes	Yes	Yes	Yes	Yes	—
Y1	—	Yes	Yes	—	—	Yes	—

When writing parallel instructions, write the B field instructions first, then write the A field instructions:

```

PADD A0,M0,A0 PMULS X0,Y0,M0 MOVX.W @R4+,X0 MOVY.W @R6+,Y0[ ; ]
DCF PINC X1,A1 MOVX.W A0,@R5+R8 MOVY.W @R7+,Y0[ ; ]
PCMP X1,M0 MOVX.W @R4+R8 [NOPY][ ; ]

```

Text in brackets ([]) can be omitted. The no operation instructions NOPX and NOPY can be omitted. Semicolons (;) are used to demarcate instruction lines, but can be omitted. If semicolons are used, the space after the semicolon can be used for comments.

The individual status codes (DC, N, Z, V, GT) of the DSR register are always updated by unconditional ALU operation instructions and shift operation instructions. Conditional instructions do not update the status codes, even if the conditions have been met. Multiplication instructions also do not update the status codes. DC bit definitions are determined by the specifications of the CS bits in the DSR register.

Table 2.34 lists the DSP operation instructions by classification.

Table 2.34 Classification of DSP Instructions

Classification		Instruction Types	Operation Code	Function	No. of Instructions
ALU arithmetic operation instructions	ALU fixed decimal point operation instructions	11	PABS	Absolute value operation	28
			PADD	Addition	
			PADD PMULS	Addition and signed multiplication	
			PADDC	Addition with carry	
			PCLR	Clear	
			PCMP	Compare	
			PCOPY	Copy	
			PNEG	Invert sign	
			PSUB	Subtraction	
			PSUB PMULS	Subtraction and signed multiplication	
			PSUBC	Subtraction with borrow	
ALU integer operation instructions	2	PDEC	Decrement	12	
		PINC	Increment		
MSB detection instruction	1	PDMSB	MSB detection	6	
Rounding operation instruction	1	PRND	Rounding	2	
ALU logical operation instructions	3	PAND	Logical AND	9	
		POR	Logical OR		
		PXOR	Logical exclusive OR		
Fixed decimal point multiplication instruction	1	PMULS	Signed multiplication	1	
Shift	Arithmetic shift operation instruction	1	PSHA	Arithmetic shift	4
	Logical shift operation instruction	1	PSHL	Logical shift	4
System control instructions	2	PLDS	System register load	12	
		PSTS	Store from system register		
Total 23				Total 78	

2.5.4 Various Operation Instructions

ALU Arithmetic Operation Instructions: Tables 2.35–2.44 list various operation instructions.

Table 2.35 ALU Fixed Point Operation Instructions

Instruction	Operation	Code	Cycles	DC Bit
PABS S_x, D_z	If $S_x \geq 0, S_x \rightarrow D_z$ If $S_x < 0, 0 - S_x \rightarrow D_z$	111110***** 10001000xx00zzzz	1	Update
PABS S_y, D_z	If $S_y \geq 0, S_y \rightarrow D_z$ If $S_y < 0, 0 - S_y \rightarrow D_z$	111110***** 1010100000yyzzzz	1	Update
PADD S_x, S_y, D_z	$S_x + S_y \rightarrow D_z$	111110***** 10110001xxyyzzzz	1	Update
DCT PADD S_x, S_y, D_z	if DC=1, $S_x + S_y \rightarrow D_z$ if 0, nop	111110***** 10110010xxyyzzzz	1	—
DCF PADD S_x, S_y, D_z	if DC=0, $S_x + S_y \rightarrow D_z$ if 1, nop	111110***** 10110011xxyyzzzz	1	—
PADD S_x, S_y, D_u	$S_x + S_y \rightarrow D_u$	111110*****	1	Update
PMULS S_e, S_f, D_g	MSW of $S_e \times S_f \rightarrow D_g$	0111eefxxyygguu		
PADDC S_x, S_y, D_z	$S_x + S_y + DC \rightarrow D_z$	111110***** 10110000xxyyzzzz	1	Update
PCLR D_z	H'00000000 $\rightarrow D_z$	111110***** 100011010000zzzz	1	Update
DCT PCLR D_z	if DC=1, H'00000000 $\rightarrow D_z$ if 0, nop	111110***** 100011100000zzzz	1	—
DCF PCLR D_z	if DC=0, H'00000000 $\rightarrow D_z$ if 1, nop	111110***** 100011110000zzzz	1	—
PCMP S_x, S_y	$S_x - S_y$	111110***** 10000100xxyy0000	1	Update
PCOPY S_x, D_z	$S_x \rightarrow D_z$	111110***** 11011001xx00zzzz	1	Update
PCOPY S_y, D_z	$S_y \rightarrow D_z$	111110***** 1111100100yyzzzz	1	Update
DCT PCOPY S_x, D_z	if DC=1, $S_x \rightarrow D_z$ if 0, nop	111110***** 11011010xx00zzzz	1	—

Table 2.35 ALU Fixed Point Operation Instructions (cont)

Instruction	Operation	Code	Cycles	DC Bit
DCT PCOPY Sy, Dz	if DC=1, Sy→Dz if 0,nop	111110***** 1111101000yyzzzz	1	—
DCF PCOPY Sx, Dz	if DC=0, Sx→Dz if 1,nop	111110***** 11011011xx00zzzz	1	—
DCF PCOPY Sy, Dz	if DC=0, Sy→Dz if 1,nop	111110***** 1111101100yyzzzz	1	—
PNEG Sx, Dz	0–Sx→Dz	111110***** 11001001xx00zzzz	1	Update
PNEG Sy, Dz	0–Sy→Dz	111110***** 1110100100yyzzzz	1	Update
DCT PNEG Sx, Dz	if DC=1, 0–Sx→Dz if 0,nop	111110***** 11001010xx00zzzz	1	—
DCT PNEG Sy, Dz	if DC=1, 0–Sy→Dz if 0,nop	111110***** 1110101000yyzzzz	1	—
DCF PNEG Sx, Dz	if DC=0, 0–Sx→Dz if 1,nop	111110***** 11001011xx00zzzz	1	—
DCF PNEG Sy, Dz	if DC=0, 0–Sy→Dz if 1,nop	111110***** 1110101100yyzzzz	1	—
PSUB Sx, Sy, Dz	Sx–Sy→Dz	111110***** 10100001xxyyzzzz	1	Update
DCT PSUB Sx, Sy, Dz	if DC=1, Sx–Sy→Dz if 0,nop	111110***** 10100010xxyyzzzz	1	—
DCF PSUB Sx, Sy, Dz	if DC=0, Sx–Sy→Dz if 1,nop	111110***** 10100011xxyyzzzz	1	—
PSUB Sx, Sy, Du	Sx–Sy→Du	111110*****	1	Update
PMULS Se, Sf, Dg	MSW of Se × MSW of Sf→Dg	0110eefxxyygguu		
PSUBC Sx, Sy, Dz	Sx–Sy–DC→Dz	111110***** 10100000xxyyzzzz	1	Update

Table 2.36 ALU Integer Operation Instructions

Instruction	Operation	Code	Cycles	DC Bit
PDEC S_x, Dz	MSW of $S_x - 1 \rightarrow$ MSW of Dz , clear LSW of Dz	111110***** 10001001xx00zzzz	1	Update
PDEC S_y, Dz	MSW of $S_y - 1 \rightarrow$ MSW of Dz , clear LSW of Dz	111110***** 1010100100yyzzzz	1	Update
DCT PDEC S_x, Dz	If DC=1, MSW of $S_x - 1 \rightarrow$ MSW of Dz , clear LSW of Dz ; if 0, nop	111110***** 10001010xx00zzzz	1	—
DCT PDEC S_y, Dz	If DC=1, MSW of $S_y - 1 \rightarrow$ MSW of Dz , clear LSW of Dz ; if 0, nop	111110***** 1010101000yyzzzz	1	—
DCF PDEC S_x, Dz	If DC=0, MSW of $S_x - 1 \rightarrow$ MSW of Dz , clear LSW of Dz ; if 1, nop	111110***** 10001011xx00zzzz	1	—
DCF PDEC S_y, Dz	If DC=0, MSW of $S_y - 1 \rightarrow$ MSW of Dz , clear LSW of Dz ; if 1, nop	111110***** 1010101100yyzzzz	1	—
PINC S_x, Dz	MSW of $S_x + 1 \rightarrow$ MSW of Dz , clear LSW of Dz	111110***** 10011001xx00zzzz	1	Update
PINC S_y, Dz	MSW of $S_y + 1 \rightarrow$ MSW of Dz , clear LSW of Dz	111110***** 1011100100yyzzzz	1	Update
DCT PINC S_x, Dz	If DC=1, MSW of $S_x + 1 \rightarrow$ MSW of Dz , clear LSW of Dz ; if 0, nop	111110***** 10011010xx00zzzz	1	—
DCT PINC S_y, Dz	If DC=1, MSW of $S_y + 1 \rightarrow$ MSW of Dz , clear LSW of Dz ; if 0, nop	111110***** 1011101000yyzzzz	1	—
DCF PINC S_x, Dz	If DC=0, MSW of $S_x + 1 \rightarrow$ MSW of Dz , clear LSW of Dz ; if 1, nop	111110***** 10011011xx00zzzz	1	—
DCF PINC S_y, Dz	If DC=0, MSW of $S_y + 1 \rightarrow$ MSW of Dz , clear LSW of Dz ; if 1, nop	111110***** 1011101100yyzzzz	1	—

Table 2.37 MSB Detection Instructions

Instruction	Operation	Code	Cycles	DC Bit
PDMSB S_x, D_z	S_x data MSB position → MSW of D_z , clear LSW of D_z	111110***** 10011101xx00zzzz	1	Update
PDMSB S_y, D_z	S_y data MSB position → MSW of D_z , clear LSW of D_z	111110***** 1011110100yyzzzz	1	Update
DCT PDMSB S_x, D_z	If DC=1, S_x data MSB position → MSW of D_z , clear LSW of D_z ; if 0, nop	111110***** 10011110xx00zzzz	1	—
DCT PDMSB S_y, D_z	If DC=1, S_y data MSB position → MSW of D_z , clear LSW of D_z ; if 0, nop	111110***** 1011111000yyzzzz	1	—
DCF PDMSB S_x, D_z	If DC=0, S_x data MSB position → MSW of D_z , clear LSW of D_z ; if 1, nop	111110***** 10011111xx00zzzz	1	—
DCF PDMSB S_y, D_z	If DC=0, S_y data MSB position → MSW of D_z , clear LSW of D_z ; if 1, nop	111110***** 1011111100yyzzzz	1	—

Table 2.38 Rounding Operation Instructions

Instruction	Operation	Code	Cycles	DC Bit
PRND S_x, D_z	$S_x + H'00008000 \rightarrow D_z$ clear LSW of D_z	111110***** 10011000xx00zzzz	1	Update
PRND S_y, D_z	$S_y + H'00008000 \rightarrow D_z$ clear LSW of D_z	111110***** 1011100000yyzzzz	1	Update

Table 2.39 ALU Logical Operation Instructions

Instruction	Operation	Code	Cycles	DC Bit
PAND Sx, Sy, Dz	$Sx \& Sy \rightarrow Dz$, clear LSW of Dz	111110***** 10010101xxyyzzzz	1	Update
DCT PAND Sx, Sy, Dz	If DC=1, $Sx \& Sy \rightarrow Dz$, clear LSW of Dz; if 0, nop	111110***** 10010110xxyyzzzz	1	—
DCF PAND Sx, Sy, Dz	If DC=0, $Sx \& Sy \rightarrow Dz$, clear LSW of Dz; if 1, nop	111110***** 10010111xxyyzzzz	1	—
POR Sx, Sy, Dz	$Sx Sy \rightarrow Dz$, clear LSW of Dz	111110***** 10110101xxyyzzzz	1	Update
DCT POR Sx, Sy, Dz	If DC=1, $Sx Sy \rightarrow Dz$, clear LSW of Dz; if 0, nop	111110***** 10110110xxyyzzzz	1	—
DCF POR Sx, Sy, Dz	If DC=0, $Sx Sy \rightarrow Dz$, clear LSW of Dz; if 1, nop	111110***** 10110111xxyyzzzz	1	—
PXOR Sx, Sy, Dz	$Sx \wedge Sy \rightarrow Dz$, clear LSW of Dz	111110***** 10100101xxyyzzzz	1	Update
DCT PXOR Sx, Sy, Dz	If DC=1, $Sx \wedge Sy \rightarrow Dz$, clear LSW of Dz; if 0, nop	111110***** 10100110xxyyzzzz	1	—
DCF PXOR Sx, Sy, Dz	If DC=0, $Sx \wedge Sy \rightarrow Dz$, clear LSW of Dz; if 1, nop	111110***** 10100111xxyyzzzz	1	—

Table 2.40 Fixed Point Multiplication Instructions

Instruction	Operation	Code	Cycles	DC Bit
PMULS Se, Sf, Dg	MSW of $Se \times MSW$ of $Sf \rightarrow Dg$	111110***** 0100eeff0000gg00	1	—

Table 2.41 Arithmetic Shift Operation Instructions

Instruction	Operation	Code	Cycles	DC Bit
PSHA Sx, Sy, Dz	if $Sy \geq 0, Sx \ll Sy \rightarrow Dz$	111110*****	1	Update
	if $Sy < 0, Sx \gg Sy \rightarrow Dz$	10010001xxyyzzzz		
DCT PSHA Sx, Sy, Dz	if DC=1 & $Sy \geq 0, Sx \ll Sy \rightarrow Dz$	111110*****	1	—
	if DC=1 & $Sy < 0, Sx \gg Sy \rightarrow Dz$	10010010xxyyzzzz		
	if DC=0, nop			
DCF PSHA Sx, Sy, Dz	if DC=0 & $Sy \geq 0, Sx \ll Sy \rightarrow Dz$	111110*****	1	—
	if DC=0 & $Sy < 0, Sx \gg Sy \rightarrow Dz$	10010011xxyyzzzz		
	if DC=1, nop			
PSHA #imm, Dz	if imm $\geq 0, Dz \ll imm \rightarrow Dz$	111110*****	1	Update
	if imm $< 0, Dz \gg imm \rightarrow Dz$	00010iiiiiiizzzz		

Table 2.42 Logical Shift Operation Instructions

Instruction	Operation	Code	Cycles	DC Bit
PSHL S_x, S_y, D_z	if $S_y \geq 0, S_x \ll S_y \rightarrow D_z$, clear LSW of D_z if $S_y < 0, S_x \gg S_y \rightarrow D_z$, clear LSW of D_z	111110***** 10000001xxxyzzzz	1	Update
DCT PSHL S_x, S_y, D_z	if $DC=1$ & $S_y \geq 0, S_x \ll S_y \rightarrow D_z$, clear LSW of D_z if $DC=1$ & $S_y < 0, S_x \gg S_y \rightarrow D_z$, clear LSW of D_z if $DC=0$, nop	111110***** 10000010xxxyzzzz	1	—
DCF PSHL S_x, S_y, D_z	if $DC=0$ & $S_y \geq 0, S_x \ll S_y \rightarrow D_z$, clear LSW of D_z if $DC=0$ & $S_y < 0, S_x \gg S_y \rightarrow D_z$, clear LSW of D_z if $DC=1$, nop	111110***** 10000011xxxyzzzz	1	—
PSHL #imm, D_z	if imm $\geq 0, D_z \ll imm \rightarrow D_z$, clear LSW of D_z if imm $< 0, D_z \gg imm \rightarrow D_z$, clear LSW of D_z	111110***** 00000iiiiiiiizzzz	1	Update

Table 2.43 System Control Instructions

Instruction	Operation	Code	Cycles	DC Bit
PLDS Dz, MACH	Dz→MACH	111110***** 111011010000zzzz	1	—
PLDS Dz, MACL	Dz→MACL	111110***** 111111010000zzzz	1	—
DCT PLDS Dz, MACH	if DC=1, Dz→MACH if 0, nop	111110***** 111011100000zzzz	1	—
DCT PLDS Dz, MACL	if DC=1, Dz→MACL if 0, nop	111110***** 111111100000zzzz	1	—
DCF PLDS Dz, MACH	if DC=0, Dz→MACH if 1, nop	111110***** 111011110000zzzz	1	—
DCF PLDS Dz, MACL	if DC=0, Dz→MACL if 1, nop	111110***** 111111110000zzzz	1	—
PSTS MACH, Dz	MACH→Dz	111110***** 110011010000zzzz	1	—
PSTS MACL, Dz	MACL→Dz	111110***** 110111010000zzzz	1	—
DCT PSTS MACH, Dz	if DC=1, MACH→Dz if 0, nop	111110***** 110011100000zzzz	1	—
DCT PSTS MACL, Dz	if DC=1, MACL→Dz if 0, nop	111110***** 110111100000zzzz	1	—
DCF PSTS MACH, Dz	if DC=0, MACH→Dz if 1, nop	111110***** 110011110000zzzz	1	—
DCF PSTS MACL, Dz	if DC=0, MACL→Dz if 1, nop	111110***** 110111110000zzzz	1	—

2.6 Usage Notes

2.6.1 When not using DSP instructions

When DSP instructions are not used, execute the following dummy instruction in the initialization section of application software in order to reduce the operating current.

```
PCLR      A0    : Clear the A0 register.  
PSHA     #5, A0 : 5 bit shift to left.
```

2.6.2 When executing a combination of double-precision multiplication or double-precision product-sum operation (CPU instruction) and DSP computing instruction

When double-precision multiplication (MUL.L, DMULU.L, DMULS.L) or double-precision product-sum operation (MAC.L) in CPU instructions is executed in combination with DSP computing instruction (when the following conditions 1 and 2 are met simultaneously), a malfunction may occur in the instructions indicated in 2-b.

1. Execution of instructions from the internal memory or cache.
2. Execution of the following instruction strings in the order of a, b and c.
 - a. Double-precision multiplication (MUL.L, DMULU.L, DMULS.L) or double-precision product-sum operation (MAC.L)
 - b. DSP computing instruction excluding PMULS, PSTS and PLDS
 - c. Execution of PMLS, PSTS or PLDS instruction

The above caution also applies when there is a delayed jump instruction immediately before the above 2-a, and the instruction 2-a is in a delayed slot, and the instructions 2-b and 2-c are described continuously at the jump destination.

To prevent the malfunction, take one of the following measures.

- 1 Do not execute the instruction string described in the above condition 2.
2. When the instruction string described in the above condition 2 exists on the instruction code and if no problem is caused by switching instructions b and c, switch the locations of instructions b and c.
3. When the instruction string described in the above condition 2 exists on the instruction code and if a problem is caused by switching instructions b and c, insert one or more NOP instructions or CPU instructions that are not related to the multiplier.

Section 3 Oscillator Circuits and Operating Modes

3.1 Overview

Operation of the on-chip clock pulse generator, and CS0 area bus width specification, are controlled by the operating mode pins. A crystal resonator or external clock can be selected as the clock source.

3.2 On-Chip Clock Pulse Generator and Operating Modes

3.2.1 Clock Pulse Generator

A block diagram of the on-chip clock pulse generator circuit is shown in figure 3.1.

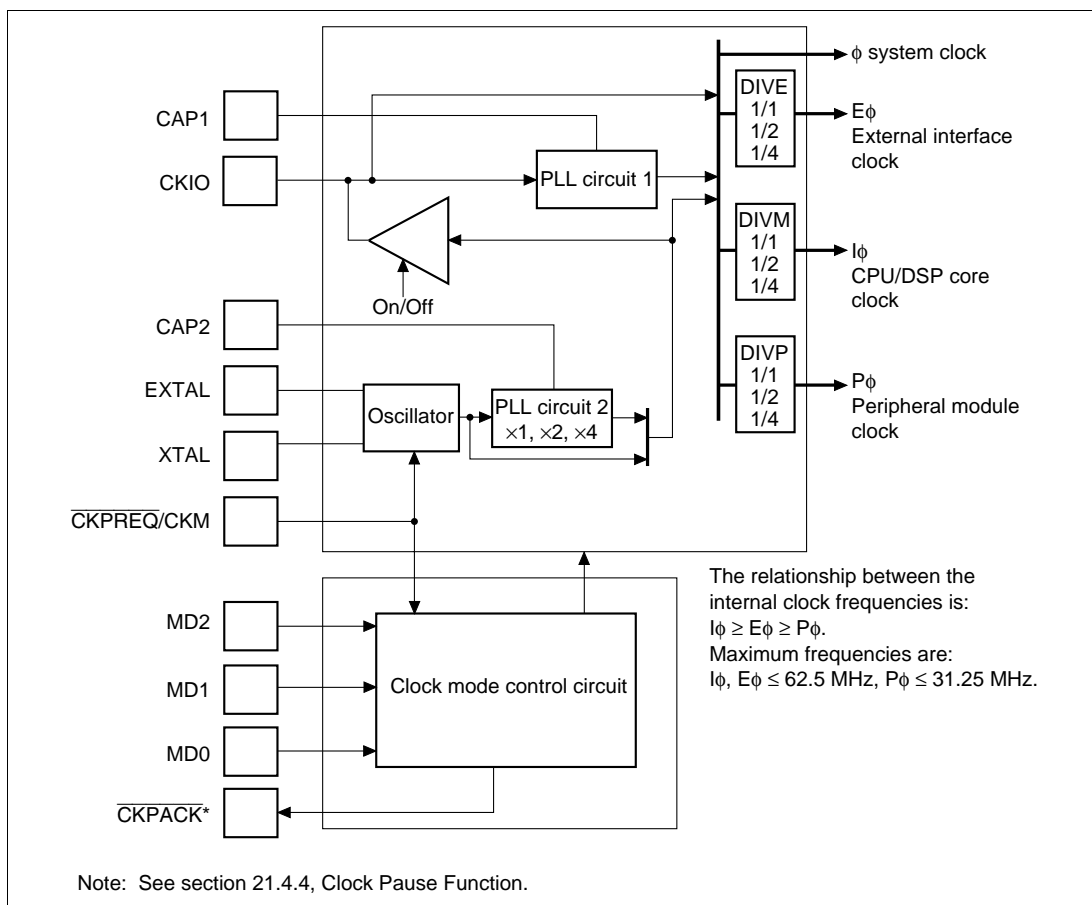

Figure 3.1 Block Diagram of Clock Pulse Generator Circuit

Pin Configuration: Table 3.1 lists the functions relating to the pins relating to the oscillator circuit.

Table 3.1 Pin Configuration

Pin Name	I/O	Function
CKIO	I/O	External clock input pin or internal clock output pin
XTAL	O	Connects to the crystal resonator
EXTAL	I	Connects to the crystal resonator or to the external clock input when using PLL circuit 2
CAP1	I	Connects to capacitance for operating PLL circuit 1
CAP2	I	Connects to capacitance for operating PLL circuit 2
MD0	I	The level applied to these pins specifies the clock mode
MD1	I	
MD2	I	
$\overline{\text{CKPREQ}}/\text{CKM}$	I	Used as the clock pause request pin, or specifies operation of the crystal resonator
$\overline{\text{CKPACK}}$	O	Clock pause function

PLL Circuit 1: PLL circuit 1 eliminates phase differences between external clocks and clocks supplied internally within the chip. In high-speed operation, the phase difference between the reference clocks and operating clocks in the chip directly affects the interface margin with peripheral devices. On-chip PLL circuit 1 is provided to eliminate this effect.

PLL Circuit 2: PLL circuit 2 either leaves unchanged, doubles, or quadruples the frequency of clocks provided from the crystal resonator or the EXTAL pin external clock input for the chip operating frequency. The frequency modification register sets the clock frequency multiplication factor.

3.2.2 Clock Operating Mode Settings

Table 3.2 lists the functions and operation of clock modes 0 to 6.

Table 3.2 Operating Modes

Clock Mode	Function/Operation	Clock Source
0	<p>PLL circuits 1 and 2 operate. A clock is output with the same phase (with the same frequency as $E\phi$) as the internal clocks ($I\phi$, $E\phi$, $P\phi$) from the CKIO pin</p> <p>PLL circuits 1 and 2 can be switched between the operating and halted states by means of control bits in the frequency modification register (FMR). The CKIO pin can also be placed in the high-impedance state</p> <p>Normally, mode 0 should be used.</p>	Crystal resonator/ external clock input
1	<p>PLL circuits 1 and 2 operate. A clock (with the same frequency as $E\phi$) $1/4 \phi$ cycle in advance of the chip's internal system clock ϕ is output from the CKIO pin.</p> <p>PLL circuits 1 and 2 can be switched between the operating and halted states by means of control bits in the frequency modification register (FMR). The CKIO pin can also be placed in the high-impedance state. However, clock phase shifting is not performed when PLL circuit 1 is halted.</p> <p>Normally, mode 0 should be used.</p>	
2	<p>Only PLL circuit 2 operates. The clock from PLL circuit 2 is output from the CKIO pin (having the same frequency as the $E\phi$). As PLL circuit 1 does not operate, phases are not matched in this mode</p> <p>PLL circuit 2 can be switched between the operating and halted states by means of a control bit in the frequency modification register (FMR). The CKIO pin can also be placed in the high-impedance state</p>	
3	<p>Only PLL circuit 2 operates. The CKIO pin is high-impedance</p> <p>PLL circuit 2 can be switched between the operating and halted states by means of a control bit in the frequency modification register (FMR)</p>	
4	<p>Only PLL circuit 1 operates. Operate PLL circuit 1 when operating with synchronization of the phases of the clock input from the CKIO pin and the internal clocks ($I\phi$, $E\phi$, $P\phi$). PLL circuit 2 does not operate in this mode</p> <p>PLL circuit 1 can be switched between the operating and halted states by means of a control bit in the frequency modification register (FMR)</p>	External clock input

Table 3.2 Operating Modes (cont)

Clock Mode	Function/Operation	Clock Source
5	<p>Only PLL circuit 1 operates. Operate PLL circuit 1 when operating with a $1/4 \phi$ cycle lag of the clock input from the CKIO pin and the internal clocks ($I\phi$, $E\phi$, $P\phi$) with respect to system clock ϕ. PLL circuit 2 does not operate in this mode</p> <p>PLL circuit 1 can be switched between the operating and halted states by means of control bits in the frequency modification register (FMR). However, clock phase shifting is not performed when PLL circuit 1 is halted.</p> <p>Normally, mode 4 should be used.</p>	External clock input
6	<p>PLL circuits 1 and 2 do not operate. Set this mode when a clock having a frequency equal to that of clocks the clock input from the CKIO pin is used</p>	

The internal clock frequency can be changed in each clock mode (see section 3.2.5, Operating Frequency Selection by Register).

In clock modes 4 to 6, the frequency of the clock input from the CKIO pin can be changed, or the clock can be stopped (see section 21.4.4, Clock Pause Function).

Table 3.3 lists the relationship between pins MD2 to MD0 and the clock operating mode. Do not switch the MD2–MD0 pins while they are operating. Switching will cause operating errors.

Table 3.3 Clock Mode Pin Settings and States

Clock Mode	Pin						
	MD2	MD1	MD0	CKPREQ/ CKM	EXTAL	XTAL	CKIO
0	0	0	0	0	Clock input	Open	Output/high
				1	Crystal oscillation	Crystal oscillation	impedance
1	0	0	1	0	Clock input	Open	Output/high
				1	Crystal oscillation	Crystal oscillation	impedance
2	0	1	0	0	Clock input	Open	Output/high
				1	Crystal oscillation	Crystal oscillation	impedance
3	0	1	1	0	Clock input	Open	High
				1	Crystal oscillation	Crystal oscillation	impedance
4	1	0	0	*	Open	Open	Clock input
5	1	0	1		Open	Open	Clock input
6	1	1	0		Open	Open	Clock input

Notes: Do not use in combinations other than those listed.

* In clock modes 4, 5, and 6, CKPREQ/CKM functions as the clock pause request pin.

3.2.3 Connecting a Crystal Resonator

Connecting a Crystal Resonator: Figure 3.2 shows an example of crystal resonator connection. The values of damping resistance R and load capacitances CL1 and CL2 should be decided after investigating the components in collaboration with the manufacturer of the crystal oscillator to be used. The crystal resonator should be an AT-cut parallel-oscillator type. Place the crystal resonator and its load capacitors as close as possible to the XTAL and EXTAL pins.

Other signal lines should be routed away from the oscillator circuit to prevent induction from interfering with correct oscillation.

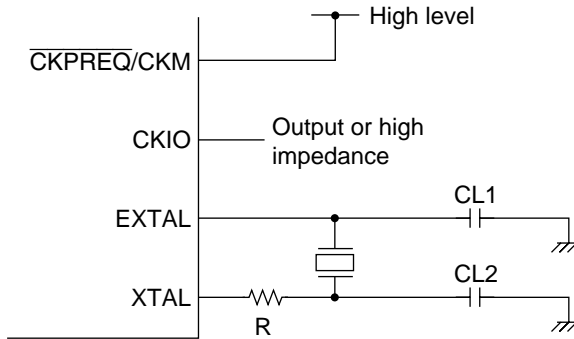

- Notes:
1. The CKIO pin is an output in clock modes 0,1, and 2. In mode 3, it is high impedance.
 2. The values for CL1, CL2, and the damping resistance should be determined after consultation with the crystal resonator manufacturer.

Figure 3.2 Example of Crystal Oscillator Connection

3.2.4 External Clock Input

An external clock is input from the EXTAL pin or the CKIO pin, depending on the clock mode.

Clock Input from EXTAL Pin: This method can be used in clock modes 0, 1, 2, and 3.

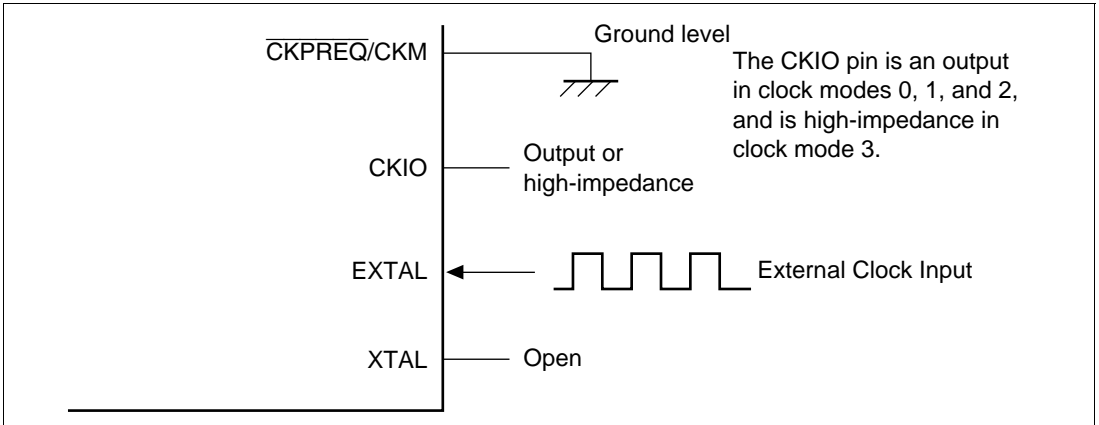

Figure 3.3 External Clock Input Method

Clock Input from CKIO Pin: This method can be used in clock modes 4, 5, and 6.

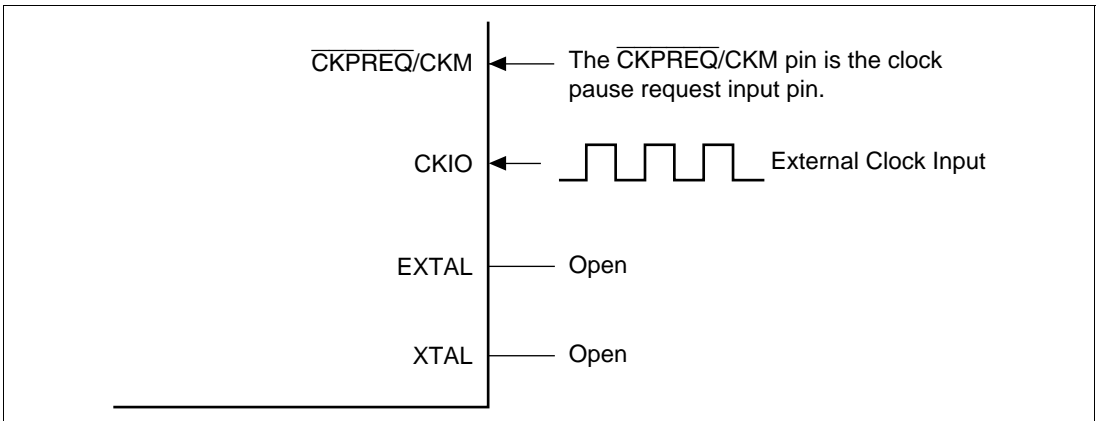

Figure 3.4 External Clock Input Method

3.2.5 Operating Frequency Selection by Register

Using the frequency modification register (FMR), it is possible to specify the operating frequency division ratio for the internal clocks (I ϕ , E ϕ , P ϕ). The internal clock frequency is determined under the control of PLL circuits 1 and 2 and dividers DIVM, DIVE, and DIVP.

Frequency Modification Register (FMR): The frequency modification register is initialized only by a power-on reset via the RES pin, and not by an internal reset resulting from WDT overflow. Its initial value depends on the settings of pins MD2–MD0. Table 3.4 shows the relationship between the MD2–MD0 pin combinations and the initial value of the frequency modification register.

Table 3.4 Relationship between Clock Mode Pin Settings and Initial Value of Frequency Modification Register

Clock Mode	MD2	MD1	MD0	Initial Value
Mode 0	0	0	0	H'00
Mode 1	0	0	1	
Mode 2	0	1	0	H'40
Mode 3	0	1	1	H'60
Mode 4	1	0	0	H'A6
Mode 5	1	0	1	
Mode 6	1	1	0	H'E0

The register configuration is shown in table 3.5.

Table 3.5 Register Configuration

Name	Abbreviation	R/W	Initial Value	Address
Frequency modification register	FMR	R/W	See table 3.4*	H'FFFFFFE90

Note: * The initial value depends on the clock mode.

Bit:	7	6	5	4	3	2	1	0
	PLL2ST	PLL1ST	CKIOST	—	FR3	FR2	FR1	FR0
Initial value:	—	—	—	0	0	—	—	0
R/W:	R/W	R/W	R/W	R	R/W	R/W	R/W	R/W

Bit 7—PLL2ST: Switching is possible in modes 0 to 3. In modes 4 to 6, PLL circuit 2 cannot be used. In these modes, this bit always reads 1.

Bit 7: PLL2ST Description

0	PLL circuit 2 used
1	PLL circuit 2 not used

Bit 6—PLL1ST: Switching is possible in modes 0, 1, 4, and 5. In modes 2, 3, and 6, PLL circuit 1 cannot be used. In these modes, this bit always reads 1.

Bit 6: PLL1ST Description

0	PLL circuit 1 is used
1	PLL circuit 1 is not used

Bit 5—CKIOST: Setting is possible in modes 0 to 3. In modes 4 to 6, the CKIO pin is an input pin. In these modes, this bit always reads 1.

Bit 5: CKIOST Description

0	The CKIO pin outputs $E\phi$
1	The CKIO pin is in the high-impedance state (Do not place CKIO in the high-impedance state when PLL circuit 1 is operating)

Bit 4—Reserved: This bit is always read as 0. The write value should always be 0.

Bits 3 to 0—FR3 to FR0: The internal clock frequency and CKIO output frequency (modes 0–2) can be set by frequency setting bits FR3–FR0. The values that can be set in bits FR3–FR0 depend on the mode and whether PLL circuit 1 and PLL circuit 2 are operating or halted. The following tables show the values that can be set in FR3–FR0, and the internal clock and CKIO output frequency ratios, taking the external input clock frequency as 1.

- Modes 0 and 1
PLL circuits 1 and 2 operating
EXTAL input or crystal resonator used

FR3	FR2	FR1	FR0	ϕ	I ϕ	E ϕ	P ϕ	CKIO
0	0	0	0	$\times 4$	$\times 1$	$\times 1$	$\times 1$	E ϕ
0	1	0	0	$\times 4$	$\times 2$	$\times 1$	$\times 1$	E ϕ
0	1	0	1	$\times 4$	$\times 2$	$\times 2$	$\times 1$	E ϕ
0	1	1	0	$\times 4$	$\times 2$	$\times 2$	$\times 2$	E ϕ
1	0	0	0	$\times 4$	$\times 4$	$\times 1$	$\times 1$	E ϕ
1	0	0	1	$\times 4$	$\times 4$	$\times 2$	$\times 1$	E ϕ
1	0	1	0	$\times 4$	$\times 4$	$\times 2$	$\times 2$	E ϕ
1	1	0	0	$\times 4$	$\times 4$	$\times 4$	$\times 1$	E ϕ
1	1	1	0	$\times 4$	$\times 4$	$\times 4$	$\times 2$	E ϕ

Note: Do not use combinations other than those shown above.

- Modes 0 to 3
PLL circuit 1 halted, PLL circuit 2 operating
EXTAL input or crystal resonator used

FR3	FR2	FR1	FR0	ϕ	I ϕ	E ϕ	P ϕ	CKIO
0	0	0	0	$\times 1$	$\times 1$	$\times 1$	$\times 1$	E ϕ
0	1	0	1	$\times 2$	$\times 2$	$\times 2$	$\times 1$	E ϕ
0	1	1	0	$\times 2$	$\times 2$	$\times 2$	$\times 2$	E ϕ
1	1	0	0	$\times 4$	$\times 4$	$\times 4$	$\times 1$	E ϕ
1	1	1	0	$\times 4$	$\times 4$	$\times 4$	$\times 2$	E ϕ

Note: Do not use combinations other than those shown above.

- Modes 0 and 1
PLL circuit 1 operating, PLL circuit 2 halted
EXTAL input or crystal resonator used

FR3	FR2	FR1	FR0	ϕ	I ϕ	E ϕ	P ϕ	CKIO
0	0	0	0	$\times 4$	$\times 1$	$\times 1$	$\times 1$	E ϕ
0	1	0	0	$\times 4$	$\times 2$	$\times 1$	$\times 1$	E ϕ
1	0	0	0	$\times 4$	$\times 4$	$\times 1$	$\times 1$	E ϕ

Note: Do not use combinations other than those shown above.

- Modes 4 and 5
PLL circuit 1 operating, PLL circuit 2 halted
CKIO input

FR3	FR2	FR1	FR0	ϕ	I ϕ	E ϕ	P ϕ	CKIO
0	1	0	1	$\times 2$	$\times 1$	$\times 1$	$\times 1/2$	E ϕ
0	1	1	0	$\times 2$	$\times 1$	$\times 1$	$\times 1$	E ϕ
1	0	0	1	$\times 2$	$\times 2$	$\times 1$	$\times 1/2$	E ϕ
1	0	1	0	$\times 2$	$\times 2$	$\times 1$	$\times 1$	E ϕ

Note: Do not use combinations other than those shown above.

- Modes 0–6
PLL circuits 1 and 2 halted
EXTAL input or crystal resonator used (modes 0–3)
CKIO input (modes 4–6)

FR3	FR2	FR1	FR0	ϕ	I ϕ	E ϕ	P ϕ	CKIO
0	0	0	0	$\times 1$	$\times 1/4$	$\times 1/4$	$\times 1/4$	$\times 1$
0	1	0	0	$\times 1$	$\times 1/2$	$\times 1/4$	$\times 1/4$	$\times 1$
0	1	0	1	$\times 1$	$\times 1/2$	$\times 1/2$	$\times 1/4$	$\times 1$
0	1	1	0	$\times 1$	$\times 1/2$	$\times 1/2$	$\times 1/2$	$\times 1$
1	0	0	0	$\times 1$	$\times 1$	$\times 1/4$	$\times 1/4$	$\times 1$
1	0	0	1	$\times 1$	$\times 1$	$\times 1/2$	$\times 1/4$	$\times 1$
1	0	1	0	$\times 1$	$\times 1$	$\times 1/2$	$\times 1/2$	$\times 1$
1	1	0	0	$\times 1$	$\times 1$	$\times 1$	$\times 1/4$	$\times 1$
1	1	1	0	$\times 1$	$\times 1$	$\times 1$	$\times 1/2$	$\times 1$
1	1	1	1	$\times 1$	$\times 1$	$\times 1$	$\times 1$	$\times 1$

Note: Do not use combinations other than those shown above.

Frequency Change: When PLL circuit 1 or PLL circuit 2 becomes operational after modifying the frequency modification register (including modification the frequency modification register in the operating state), access the frequency modification register using the following procedure, and noting the cautions listed below.

Frequency change procedure

- Set the on-chip watchdog timer (WDT) overflow time to secure the PLL circuit oscillation settling time (CKS2–CKS0 bits in WTCSR).
- Clear the WT/\overline{IT} and TME bit to 0 in WTCSR.
- Perform a read anywhere in an external memory area 0–4 cache-through area.
- Change the frequency modification register to the target frequency, or change the operating/halted state of the PLL circuits 1 and 2 (the clocks will stop temporarily inside the chip).
- The oscillation circuits operate, and the clock is supplied to the WDT. This clock increments the WDT.
- On WDT overflow, supply of a clock with the frequency set in frequency setting bits FR3–FR0 begins. In this case, the OVF bit in WTCSR and the WOVF bit in RSTCSR are not set, an interval timer interrupt (ITI) is not requested, and the \overline{WDTOVF} signal is not asserted.

Sample code for changing the frequency is shown below.

```

;      SH7616 frequency change
;
;
FMR    .equ    h'fffffe90
WTCSR  .equ    h'fffffe80
RSTCSR .equ    h'fffffe83

PACR   .equ    h'fffffc80

XRAM   .equ    h'1000e000

```

```

.export _init_FMR

```

```

_init_FMR:

```

```

    mov.l    #XRAM,r1
    mov.l    r1,r5
    mov.l    #FREQUENCY,r2
    mov.l    #FREQUENCY_END,r3

```

```

program_move:

```

```

    mov.w    @r2,r0
    mov.w    r0,@r1
    add     #2,r1
    add     #2,r2
    cmp/eq  r2,r3
    bf      program_move
    nop

```

```

    mov.l    #PACR,r1
    mov.w    #h'0008,r0
    mov.w    r0,@r1

```

```

MOV.L    #WTCSR,R1
MOV.W    #H'A51F,R2

```

```

MOV.L   #H'26200000,R3
MOV.L   #FMR,R4

        jmp    @r5
        nop
        nop
        nop
        nop
        nop
clock4_err:
        bra    clock4_err
        nop
        nop
        nop
        nop
;
;      Main portion of frequency change code.
;      First copy this to XRAM and then run it in XRAM.
FREQUENCY:
        ; <Watchdog timer control and status register setting>
        ; Clear TME bit.
        ; Clock input to WTCNT is  $\phi/16384$ 
        ; (Overflow frequency = 262.144 ms)
        MOV.W  R2,@R1

        ; <External cache through area read>
        ; Cache through area of external member space 3: H'26200000
        MOV.L  @R3,R0

        ; <Frequency change register setting>
        ; PLL circuit 1 → Disabled.
        ; PLL circuit 1 → Enabled.
        ;  $I\phi(\times 4) = 62.5$  MHz,  $E\phi(\times 4) = 62.5$  MHz,
        ;  $P\phi(\times 2) = 31.25$  MHz, CKIO ( $E\phi$ ) = 62.5 MHz,
        ;   MOV    #H'4E,R0

        ; PLL circuits 1 and 2 → Enabled.

```

```

; I $\phi$  ( $\times 4$ ) = 62.5 MHz, E $\phi$  ( $\times 2$ ) = 31.25 MHz,
; P $\phi$  ( $\times 2$ ) = 31.25 MHz, CKIO (E $\phi$ ) = 31.25 MHz,
    MOV    #H' 0A, R0

; PLL circuits 1 and 2  $\rightarrow$  Enabled.
; I $\phi$  ( $\times 4$ ) = 62.5 MHz, E $\phi$  ( $\times 1$ ) = 15.625 MHz,
; P $\phi$  ( $\times 1$ ) = 15.625 MHz, CKIO (E $\phi$ ) = 15.625 MHz,
;    MOV    #H' 08, R0

```

```
MOV.B    R0, @R4
```

```
rts
```

```
nop
```

```
FREQUENCY_END:
```

```
NOP
```

```
.END
```

Cautions

- The read from the external memory space 0–4 cache-through area and the write to the frequency modification register should be performed in on-chip X/Y memory. After reading from the external memory space 0–4 cache-through area, do not perform any write operations in external memory spaces 0–4 until the write to the frequency modification register.
- When the write access to the frequency modification register is executed, the WDT starts automatically.
- Do not turn off the CKIO output when PLL circuit 1 is in the operating state.
- The CKIO output will be unstable until the PLL circuit stabilizes.
- When a frequency is modified, halt the on-chip DMAC (E-DMAC and DMAC) operation before the frequency modification.

If PLL circuit 1 or PLL circuit 2 does not become operational after modifying the frequency modification register (including modification in the operating state), it means that the above procedure or cautions have not been properly observed. In this case, the WDT will not operate even though the frequency modification register is modified.

3.2.6 Clock Modes and Frequency Ranges

The following table shows the operating modes and the associated frequency ranges for input clocks.

Mode	Pin	Clock Input		PLL Circuit		Internal Clock*2:*3			CKIO Output (MHz)
		Input Frequency Range (MHz)	PLL1	PLL2	I ϕ (MHz)	E ϕ (MHz)	P ϕ (MHz)		
0, 1	EXTAL or crystal resonator*1	8–15.625	On	On	8–62.5	8–62.5	8–31.25	8–62.5	
			Off	On	8–62.5	8–62.5	8–31.25	8–62.5	
			On	Off	8–62.5	8–15.625	8–15.625	8–15.625	
		1–31.25	Off	Off	1–31.25	1–31.25	1–31.25	1–31.25	
2		8–15.625	Off	On	8–62.5	8–62.5	8–31.25	8–62.5	
					1–31.25	Off	1–31.25	1–31.25	1–31.25
3		8–15.625		On	8–62.5	8–62.5	8–31.25	—	
				Off	1–31.25	1–31.25	1–31.25	—	
4, 5	CKIO	16–31.25	On	Off	16–62.5	16–31.25	16–31.25	—	
					1–31.25	Off	1–31.25	1–31.25	1–31.25
					1–31.25	Off	1–31.25	1–31.25	1–31.25
6		1–31.25	Off		1–31.25	1–31.25	1–31.25	—	

Notes: *1 When a crystal resonator is used, set the frequency in the range of 8 to 15.625 MHz.

*2 Set the frequency modification register so that the frequency of all internal clocks is 1 MHz or higher.

*3 Use internal clock frequencies such that $I\phi \geq E\phi \geq P\phi$.

3.2.7 Notes on Board Design

When Using an External Crystal Oscillator: Place the crystal resonator, capacitors CL1 and CL2, and damping resistor R close to the EXTAL and XTAL pins. To prevent induction from interfering with correct oscillation, use a common grounding point for the capacitors connected to the resonator, and do not locate a wiring pattern near these components.

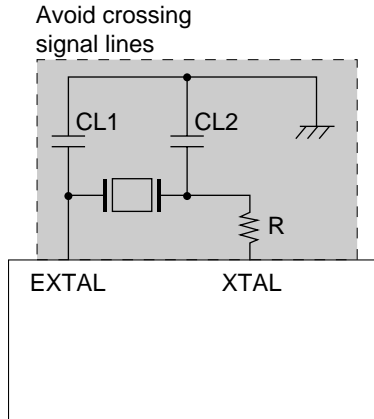

Note: The values for CL1, CL2, and the damping resistance should be determined after consultation with the crystal resonator manufacturer.

Figure 3.5 Points for Attention when Using Crystal Resonator

Bypass Capacitors: As far as possible, insert a laminated ceramic capacitor of 0.01 to 0.1 μF as a bypass capacitor for each $V_{\text{SS}}/V_{\text{CC}}$ pair. Mount the bypass capacitors as close as possible to the LSI power supply pins, and use components with a frequency characteristic suitable for the LSI operating frequency, as well as a suitable capacitance value.

$V_{\text{SS}}/V_{\text{CC}}$ pairs

PLL system: 9-12

3 V digital system: 20-18, 26-22, 35-33, 45-42, 52-50, 60-58, 61-67, 69-66, 78-76, 79-81, 91-89, 101-99, 112-109, 113-110, 114-116, 130-132, 149-146, 150-147

5 V digital system: 157-155, 169-167, 181-179, 191-193, 202-200

When Using a PLL Oscillator Circuit: Keep the wiring short from the PLL V_{CC} and V_{SS} connection pattern to the power supply pins, and make the pattern width large, to minimize the inductance component. Ground the oscillation stabilization capacitors C1 and C2 to V_{SS} (PLL1) and V_{SS} (PLL2), respectively. Place C1 and C2 close to the CAP1 and CAP2 pins and do not locate a wiring pattern in the vicinity.

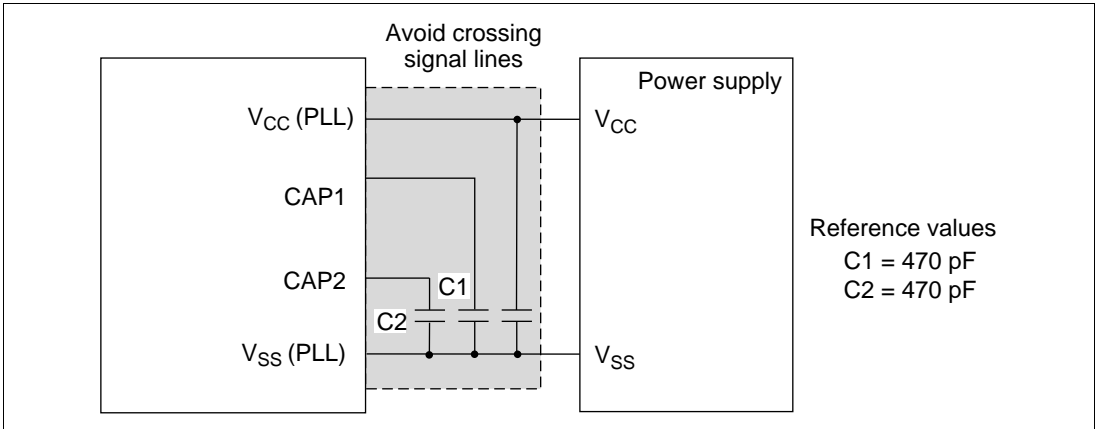

Figure 3.6 Points for Attention when Using PLL Oscillator Circuit

3.3 Bus Width of the CS0 Area

Pins MD3 and MD4 are used to specify the bus width of the CS0 area. The pin combination and functions are listed in table 3.6. Do not switch the MD4 and MD3 pins while they are operating. Switching them will cause operating errors.

Table 3.6 Bus Width of the CS0 Area

Pin		Function
MD4	MD3	
0	0	8-bit bus width selected
0	1	16-bit bus width selected
1	0	32-bit bus width selected
1	1	Setting prohibited

Section 4 Exception Handling

4.1 Overview

4.1.1 Types of Exception Handling and Priority Order

Exception handling is initiated by four sources: resets, address errors, interrupts, and instructions (table 4.1). When several exception sources occur simultaneously, they are accepted and processed according to the priority order shown in table 4.1.

Table 4.1 Types of Exception Handling and Priority Order

Exception	Source	Priority	
Reset	Power-on reset	High ↑	
	Manual reset		
Address error	CPU address error		
	DMA address error (DMAC and E-DMAC)		
Interrupt	NMI		
	User break		
	Hitachi user debug interface (H-UDI)		
	External interrupts (IRL1–IRL15, IRQ0–IRQ3 (set with IRL3, IRL2, IRL1, IRL0 pins))		
	On-chip peripheral modules		Direct memory access controller (DMAC)
			Watchdog timer (WDT)
			Compare match interrupt (part of the bus state controller)
			Ethernet controller (EtherC) and Ethernet controller direct memory access controller (E-DMAC)
			16-bit free-running timer (FRT)
			Serial communication interface with FIFO (SCIF)
	16-bit timer pulse unit (TPU)		
	Serial I/O with FIFO (SIOF)		
	Serial I/O (SIO)		
Instructions	Trap instruction (TRAPA)	↓	
	General illegal instructions (undefined code)		
	Illegal slot instructions (undefined code placed directly following a delayed branch instruction*1 or instructions that rewrite the PC*2)		

Notes: *1 Delayed branch instructions: JMP, JSR, BRA, BSR, RTS, RTE, BF/S, BT/S, BSRF, BRAF

*2 Instructions that rewrite the PC: JMP, JSR, BRA, BSR, RTS, RTE, BT, BF, TRAPA, BF/S, BT/S, BSRF, BRAF

4.1.2 Exception Handling Operations

Exception handling sources are detected, and exception handling started, according to the timing shown in table 4.2.

Table 4.2 Timing of Exception Source Detection and Start of Exception Handling

Exception Source		Timing of Source Detection and Start of Handling
Reset	Power-on reset	Starts when the NMI pin is high and the $\overline{\text{RES}}$ pin changes from low to high
	Manual reset	Starts when the NMI pin is low and the $\overline{\text{RES}}$ pin changes from low to high
Address error		Detected when instruction is decoded and starts when the previous executing instruction finishes executing
Interrupts		Detected when instruction is decoded and starts when the previous executing instruction finishes executing
Instructions	Trap instruction	Starts from the execution of a TRAPA instruction
	General illegal instructions	Starts from the decoding of undefined code anytime except after a delayed branch instruction (delay slot)
	Illegal slot instructions	Starts from the decoding of undefined code placed directly following a delayed branch instruction (delay slot) or of an instruction that rewrites the PC

When exception handling starts, the CPU operates as follows:

1. Exception handling triggered by reset

The initial values of the program counter (PC) and stack pointer (SP) are fetched from the exception vector table (PC and SP are respectively addresses H'00000000 and H'00000004 for a power-on reset and addresses H'00000008 and H'0000000C addresses for a manual reset). See section 4.1.3, Exception Vector Table, for more information. 0 is then written to the vector base register (VBR) and 1111 is written to the interrupt mask bits (I3–I0) of the status register (SR). The program begins running from the PC address fetched from the exception vector table.

2. Exception handling triggered by address errors, interrupts, and instructions

SR and PC are saved to the stack address indicated by R15. For interrupt exception handling, the interrupt priority level is written to the SR's interrupt mask bits (I3–I0). For address error and instruction exception handling, the I3–I0 bits are not affected. The start address is then fetched from the exception vector table and the program begins running from that address.

4.1.3 Exception Vector Table

Before exception handling begins, the exception vector table must be written in memory. The exception vector table stores the start addresses of exception service routines. (The reset exception table holds the initial values of PC and SP.)

All exception sources are given different vector numbers and vector table address offsets, from which the vector table addresses are calculated. In exception handling, the start address of the exception service routine is fetched from the exception vector table as indicated by the vector table address.

Table 4.3 lists the vector numbers and vector table address offsets. Table 4.4 shows vector table address calculations.

Table 4.3 (a) Exception Vector Table

Exception Source		Vector Number	Vector Table Address Offset	Vector Address
Power-on reset	PC	0	H'00000000–H'00000003	Vector number × 4
	SP	1	H'00000004–H'00000007	
Manual reset	PC	2	H'00000008–H'0000000B	
	SP	3	H'0000000C–H'0000000F	
General illegal instruction		4	H'00000010–H'00000013	VBR + (vector number × 4)
(Reserved by system)		5	H'00000014–H'00000017	
Slot illegal instruction		6	H'00000018–H'0000001B	
(Reserved by system)		7	H'0000001C–H'0000001F	
		8	H'00000020–H'00000023	
CPU address error		9	H'00000024–H'00000027	
DMA address error (DMAC and E-DMAC)		10*5	H'00000028–H'0000002B	
Interrupt	NMI	11	H'0000002C–H'0000002F	
	User break	12	H'00000030–H'00000033	
	H-UDI	13	H'00000034–H'00000037	
(Reserved by system)		14	H'00000038–H'0000003B	
		:	:	
		31	H'0000007C–H'0000007F	
Trap instruction (user vector)		32	H'00000080–H'00000083	
		:	:	
		63	H'000000FC–H'000000FF	

Table 4.3 (b) Exception Processing Vector Table (IRQ Mode)

Exception Source	Vector Number	Vector Table Address Offset	Vector Addresses
Interrupt	IRQ0	64* ²	H'00000100–H'00000103
	IRQ1	65* ²	H'00000104–H'00000107
	IRQ2	66* ²	H'00000108–H'0000010B
	IRQ3	67* ²	H'0000010C–H'0000010F
	On-chip peripheral module* ³	0* ⁴ : 127* ⁴	H'00000000–H'00000003 : H'000001FC–H'000001FF

Table 4.3 (c) Exception Processing Vector Table (IRL Mode)

Exception Source	Vector Number	Vector Table Address Offset	Vector Addresses
Interrupt	IRL1* ¹	64* ²	H'00000100–H'00000103
	IRL2* ¹	65* ²	H'00000104–H'00000107
	IRL3* ¹		
	IRL4* ¹	66* ²	H'00000108–H'0000010B
	IRL5* ¹		
	IRL6* ¹	67* ²	H'0000010C–H'0000010F
	IRL7* ¹		
	IRL8* ¹	68* ²	H'00000110–H'00000113
	IRL9* ¹		
	IRL10* ¹	69* ²	H'00000114–H'00000117
	IRL11* ¹		
	IRL12* ¹	70* ²	H'00000118–H'0000011B
	IRL13* ¹		
	IRL14* ¹	71* ²	H'0000011C–H'0000011F
	IRL15* ¹		
On-chip peripheral module* ³	0* ⁴ : 127* ⁴	H'00000000–H'00000003 : H'000001FC–H'000001FF	VBR + (vector number × 4)

Notes: *1 When 1110 is input to the IRL3, IRL2, IRL1, and IRL0 pins, an IRL1 interrupt results. When 0000 is input, an IRL15 interrupt results.

*2 External vector number fetches can be performed without using the auto-vector numbers in this table.

- *3 The vector numbers and vector table address offsets for each on-chip peripheral module interrupt are given table 5.4, Interrupt Exception Vectors and Priorities, in section 5, Interrupt Controller.
- *4 Vector numbers are set in the on-chip vector number register. See section 5.3, Register Descriptions, in section 5, Interrupt Controller, and section 11, Direct Memory Access Controller, for more information.
- *5 The same vector number, 10, is generated for a DMAC DMA address error and an E-DMAC DMA address error. (See table 4.3 (a).)

Both the address error flag (AE) in the DMAC's DMA operation register (DMAOR) and the address error control bit (AEC) in the E-DMAC's E-DMAC operation control register (EDOCR) must therefore be read in the exception service routine to determine which DMA address error has occurred.

Table 4.4 Calculating Exception Vector Table Addresses

Exception Source	Vector Table Address Calculation
Power-on reset	(Vector table address) = (vector table address offset)
Manual reset	= (vector number) × 4
Other exception handling	(Vector table address) = VBR + (vector table address offset)
	= VBR + (vector number) × 4

Note: VBR: Vector base register
 Vector table address offset: See table 4.3.
 Vector number: See table 4.3.

4.2 Resets

4.2.1 Types of Resets

Resets have the highest priority of any exception source. There are two types of resets: manual resets and power-on resets. As table 4.5 shows, both types of resets initialize the internal status of the CPU. In power-on resets, all registers of the on-chip peripheral modules are initialized; in manual resets, registers of all on-chip peripheral modules except the bus state controller (BSC), user break controller (UBC), pin function controller (PFC), and frequency modification register (FMR) are initialized. (Use the power-on reset when turning the power on.)

Table 4.5 Types of Resets

Type	Conditions for Transition to Reset Status		Internal Status	
	NMI Pin	$\overline{\text{RES}}$ Pin	CPU	On-Chip Peripheral Modules
Power-on reset	High	Low	Initialized	Initialized
Manual reset	Low	Low	Initialized	Initialized except for BSC, UBC, PFC, and frequency modification register (FMR)

4.2.2 Power-On Reset

When the NMI pin is high and the $\overline{\text{RES}}$ pin is driven low, the device performs a power-on reset. For a reliable reset, the $\overline{\text{RES}}$ pin should be kept low for at least the duration of the oscillation settling time (when the PLL circuit is halted) or for $20t_{\text{pvc}}$ (when the PLL circuit is running). During a power-on reset, the CPU's internal state and all on-chip peripheral module registers are initialized. See appendix B, Pin States, for the state of individual pins in the power-on reset state.

In a power-on reset, power-on reset exception handling starts when the NMI pin is kept high and the $\overline{\text{RES}}$ pin is first driven low for a set period of time and then returned to high. The CPU will then operate as follows:

1. The initial value (execution start address) of the program counter (PC) is fetched from the exception vector table.
2. The initial value of the stack pointer (SP) is fetched from the exception vector table.
3. The vector base register (VBR) is cleared to H'00000000 and the interrupt mask bits (I3–I0) of the status register (SR) are set to H'F (1111).
4. The values fetched from the exception vector table are set in the program counter (PC) and stack pointer (SP), and the program begins executing.

4.2.3 Manual Reset

When the NMI pin is low and the $\overline{\text{RES}}$ pin is driven low, the device executes a manual reset. For a reliable reset, the $\overline{\text{RES}}$ pin should be kept low for at least 20 clock cycles. During a manual reset, the CPU's internal state is initialized. All on-chip peripheral module registers are initialized, except for the bus state controller (BSC), user break controller (UBC), and pin function controller (PFC) registers, and the frequency modification register (FMR). When the chip enters the manual reset state in the middle of a bus cycle, manual reset exception handling does not start until the bus cycle has ended. Thus, manual resets do not abort bus cycles. See appendix B, Pin States, for the state of individual pins in the manual reset state.

In a manual reset, manual reset exception handling starts when the NMI pin is kept low and the $\overline{\text{RES}}$ pin is first kept low for a set period of time and then returned to high. The CPU will then operate in the same way as for a power-on reset.

4.3 Address Errors

4.3.1 Sources of Address Errors

Address errors occur when instructions are fetched or data read or written, as shown in table 4.6.

Table 4.6 Bus Cycles and Address Errors

Bus Cycle			
Type	Bus Master	Bus Cycle Description	Address Errors
Instruction fetch	CPU	Instruction fetched from even address	None (normal)
		Instruction fetched from odd address	Address error occurs
		Instruction fetched from other than on-chip peripheral module space	None (normal)
		Instruction fetched from on-chip peripheral module space	Address error occurs
Data read/write	CPU or DMAC, E-DMAC	Word data accessed from even address	None (normal)
		Word data accessed from odd address	Address error occurs
		Longword data accessed from a longword boundary	None (normal)
		Longword data accessed from other than a longword boundary	Address error occurs
		Access of cache purge space, address array read/write space, on-chip peripheral module space, or synchronous DRAM mode setting space by PC-relative addressing	Address error occurs
		Access of cache purge space, address array read/write space, data array read/write space, on-chip peripheral module space, or synchronous DRAM mode setting space by a TAS.B instruction	Address error occurs
		Byte, word, or longword data accessed in on-chip peripheral module space at addresses H'FFFFFFC00 to H'FFFFFFCFF	None (normal)
		Longword data accessed in on-chip peripheral module space at addresses H'FFFFFFE00 to H'FFFFFFE0F	Address error occurs
		Word or byte data accessed in on-chip peripheral module space at addresses H'FFFFFFE00 to H'FFFFFFE0F	None (normal)
		Byte data accessed in on-chip peripheral module space at addresses H'FFFFFF000 to H'FFFFFF00F or H'FFFFFFF00 to H'FFFFFFF0F	Address error occurs
Word or longword data accessed in on-chip peripheral module space at addresses H'FFFF0000 to H'FFFF000F or H'FFFFF000 to H'FFFFF00F	None (normal)		

- Notes: 1. Address errors do not occur during the synchronous DRAM mode register write cycle.
2. 16-byte DMAC transfers use longword accesses.

4.3.2 Address Error Exception Handling

When an address error occurs, address error exception handling begins after the end of the bus cycle in which the error occurred and completion of the executing instruction. The CPU operates as follows:

1. The status register (SR) is saved to the stack.
2. The program counter (PC) is saved to the stack. The PC value saved is the start address of the instruction to be executed after the last instruction executed .
3. The exception service routine start address is fetched from the exception vector table entry that corresponds to the address error that occurred, and the program starts executing from that address. The jump that occurs is not a delayed branch.

Note: The same vector number, 10, is generated for a DMAC DMA address error and an E-DMAC DMA address error. (See table 4.3 (a).)

Both the address error flag (AE) in the DMAC's DMA operation register (DMAOR) and the address error control bit (AEC) in the E-DMAC's E-DMAC operation control register (EDOCR) must therefore be read in the exception service routine to determine which DMA address error has occurred.

4.4 Interrupts

4.4.1 Interrupt Sources

Table 4.7 shows the sources that initiate interrupt exception handling. These are divided into NMI, user breaks, H-UDI, IRL, IRQ, and on-chip peripheral modules.

Table 4.7 Types of Interrupt Sources

Type	Request Source	Number of Sources
NMI	NMI pin (external input)	1
User break	User break controller (UBC)	1
H-UDI	Hitachi user debug interface (H-UDI)	1
IRL	IRL1–IRL15 (external input)	15
IRQ	IRQ0–IRQ3 (external input)	4
On-chip peripheral module	Direct memory access controller (DMAC)	2
	Ethernet controller (EtherC) and Ethernet controller direct memory access controller (E-DMAC)	1
	16-bit free-running timer (FRT)	3
	Watchdog timer (WDT)	1
	Bus state controller (BSC)	1
	Serial I/O with FIFO (SIOF)	4
	Serial I/O (SIO)	4
	Serial communication interface with FIFO (SCIF)	4
	16-bit timer pulse unit (TPU)	13

Each interrupt source is allocated a different vector number and vector table address offset. See table 5.4, Interrupt Exception Vectors and Priority Order, in section 5, Interrupt Controller, for more information.

4.4.2 Interrupt Priority Levels

The interrupt priority order is predetermined. When multiple interrupts occur simultaneously, the interrupt controller (INTC) determines their relative priorities and begins exception handling accordingly.

The priority order of interrupts is expressed as priority levels 0–16, with priority 0 the lowest and priority 16 the highest. The NMI interrupt has priority 16 and cannot be masked, so it is always accepted. The user break interrupt priority level is 15 and IRL interrupts have priorities of 1–15. On-chip peripheral module interrupt priority levels can be set freely using the INTC's interrupt priority level setting registers A–E (IPRA–IPRE) as shown in table 4.8. The priority levels that can be set are 0–15. Level 16 cannot be set. For more information on IPRA–IPRE, see sections 5.3.1, Interrupt Priority Level Setting Register A (IPRA), to 5.3.5, Interrupt Priority Level Setting Register E (IPRE).

Table 4.8 Interrupt Priority Order

Type	Priority Level	Comment
NMI	16	Fixed priority level. Cannot be masked
User break	15	Fixed priority level
H-UDI	15	Fixed priority level
IRL	1–15	Set with IRL3–IRL0 pins
IRQ	0–15	Set with interrupt priority level setting register C (IPRC)
On-chip peripheral module	0–15	Set with interrupt priority level setting registers A, B, D, and E (IPRA, IPRB, IPRD, IPRE)

4.4.3 Interrupt Exception Handling

When an interrupt occurs, its priority level is ascertained by the interrupt controller (INTC). NMI is always accepted, but other interrupts are only accepted if they have a priority level higher than the priority level set in the interrupt mask bits (I3–I0) of the status register (SR).

When an interrupt is accepted, exception handling begins. In interrupt exception handling, the CPU saves SR and the program counter (PC) to the stack. The priority level value of the accepted interrupt is written to SR bits I3–I0. For NMI, however, the priority level is 16, but the value set in I3–I0 is H'F (level 15). Next, the start address of the exception service routine is fetched from the exception vector table for the accepted interrupt, that address is jumped to and execution begins. For more information about interrupt exception handling, see section 5.4, Interrupt Operation.

4.5 Exceptions Triggered by Instructions

4.5.1 Instruction-Triggered Exception Types

Exception handling can be triggered by a trap instruction, general illegal instruction or illegal slot instruction, as shown in table 4.9.

Table 4.9 Types of Exceptions Triggered by Instructions

Type	Source Instruction	Comment
Trap instruction	TRAPA	—
Illegal slot instruction	Undefined code placed immediately after a delayed branch instruction (delay slot) and instructions that rewrite the PC	Delayed branch instructions: JMP, JSR, BRA, BSR, RTS, RTE, BF/S, BT/S, BSRF, BRAF Instructions that rewrite the PC: JMP, JSR, BRA, BSR, RTS, RTE, BT, BF, TRAPA, BF/S, BT/S, BSRF, BRAF
General illegal instruction	Undefined code anywhere besides in a delay slot	—

4.5.2 Trap Instructions

When a TRAPA instruction is executed, trap instruction exception handling starts. The CPU operates as follows:

1. The status register (SR) is saved to the stack.
2. The program counter (PC) is saved to the stack. The PC value saved is the start address of the instruction to be executed after the TRAPA instruction.
3. The exception service routine start address is fetched from the exception vector table entry that corresponds to the vector number specified by the TRAPA instruction. That address is jumped to and the program starts executing. The jump that occurs is not a delayed branch.

4.5.3 Illegal Slot Instructions

An instruction placed immediately after a delayed branch instruction is said to be placed in a delay slot. If the instruction placed in the delay slot is undefined code, illegal slot exception handling begins when the undefined code is decoded. Illegal slot exception handling is also started when an instruction that rewrites the program counter (PC) is placed in a delay slot. The exception handling starts when the instruction is decoded. The CPU handles an illegal slot instruction as follows:

1. The status register (SR) is saved to the stack.
2. The program counter (PC) is saved to the stack. The PC value saved is the jump address of the delayed branch instruction immediately before the undefined code or the instruction that rewrites the PC.
3. The exception service routine start address is fetched from the exception vector table entry that corresponds to the exception that occurred. That address is jumped to and the program starts executing. The jump that occurs is not a delayed branch.

4.5.4 General Illegal Instructions

When undefined code placed anywhere other than immediately after a delayed branch instruction (i.e., in a delay slot) is decoded, general illegal instruction exception handling starts. The CPU handles general illegal instructions in the same way as illegal slot instructions. Unlike processing of illegal slot instructions, however, the program counter value saved is the start address of the undefined code.

4.6 When Exception Sources Are Not Accepted

When an address error or interrupt is generated after a delayed branch instruction or interrupt-disabled instruction, it is sometimes not immediately accepted but is stored instead, as described in table 4.10. When this happens, it will be accepted when an instruction for which exception acceptance is possible is decoded.

Table 4.10 Exception Source Generation Immediately after a Delayed Branch Instruction or Interrupt-Disabled Instruction

Point of Occurrence	Exception Source	
	Address Error	Interrupt
Immediately after a delayed branch instruction* ¹	Not accepted	Not accepted
Immediately after an interrupt-disabled instruction* ²	Accepted	Not accepted
A repeat loop comprising up to three instructions (instruction fetch cycle not generated)	Not accepted	Not accepted
First instruction or last three instructions in a repeat loop containing four or more instructions		
Fourth from last instruction in a repeat loop containing four or more instructions	Accepted	Not accepted

Notes: *1 Delayed branch instructions: JMP, JSR, BRA, BSR, RTS, RTE, BF/S, BT/S, BSRF, BRAF

*2 Interrupt-disabled instructions: LDC, LDC.L, STC, STC.L, LDS, LDS.L, STS, STS.L

4.6.1 Immediately after a Delayed Branch Instruction

When an instruction placed immediately after a delayed branch instruction (delay slot) is decoded, neither address errors nor interrupts are accepted. The delayed branch instruction and the instruction located immediately after it (delay slot) are always executed consecutively, so no exception handling occurs between the two.

4.6.2 Immediately after an Interrupt-Disabled Instruction

When an instruction immediately following an interrupt-disabled instruction is decoded, interrupts are not accepted. Address errors are accepted.

4.6.3 Instructions in Repeat Loops

If a repeat loop comprises up to three instructions, neither exceptions nor interrupts are accepted. If a repeat loop contains four or more instructions, neither exceptions nor interrupts are accepted during the execution cycle of the first instruction or the last three instructions. If a repeat loop contains four or more instructions, address errors only are accepted during the execution cycle of the fourth from last instruction. For more information, see the *SH-1/SH-2/SH-DSP Programming Manual*.

- A. All interrupts and address errors are accepted.
- B. Address errors only are accepted.
- C. No interrupts or address errors are accepted.

When $RC \geq 1$

(1) One instruction

```
instr0 ← A
Start (End): instr1 ← B
instr2 ← C
instr2 ← A
```

(2) Two instructions

```
instr0 ← A
Start: instr1 ← B
End: instr2 ← C
instr3 ← C
instr3 ← A
```

(3) Three instructions

```
instr0 ← A
Start: instr1 ← B
instr2 ← C
End: instr3 ← C
instr4 ← C
instr4 ← A
```

(4) Four or more instructions

```
instr0 ← A
Start: instr1 ← A or C (on return from instr n)
:
:
instr n-3 ← A
instr n-2 ← B
instr n-1 ← C
End: instr n ← C
instr n+1 ← A
```

When $RC = 0$

All interrupts and address errors are accepted.

Figure 4.1 Interrupt Acceptance Restrictions in Repeat Mode

4.7 Stack Status after Exception Handling

The status of the stack after exception handling ends is as shown in table 4.11.

Table 4.11 Stack Status after Exception Handling

Type	Stack Status		
Address error	SP →	Address of instruction after executed instruction	32 bits
		SR	32 bits
Trap instruction	SP →	Address of instruction after TRAPA instruction	32 bits
		SR	32 bits
General illegal instruction	SP →	Start address of illegal instruction	32 bits
		SR	32 bits
Interrupt	SP →	Address of instruction after executed instruction	32 bits
		SR	32 bits
Illegal slot instruction	SP →	Jump destination address of delayed branch instruction	32 bits
		SR	32 bits

4.8 Usage Notes

4.8.1 Value of Stack Pointer (SP)

The value of the stack pointer must always be a multiple of four, otherwise an address error will occur when the stack is accessed during exception handling.

4.8.2 Value of Vector Base Register (VBR)

The value of the vector base register must always be a multiple of four, otherwise an address error will occur when the vector table is accessed during exception handling.

4.8.3 Address Errors Caused by Stacking of Address Error Exception Handling

If the stack pointer value is not a multiple of four, an address error will occur during stacking of the exception handling (interrupts, etc.). Address error exception handling will begin after the original exception handling ends, but address errors will continue to occur. To ensure that address error exception handling does not go into an endless loop, no address errors are accepted at that point. This allows program control to be shifted to the address error exception service routine and enables error handling to be carried out.

When an address error occurs during exception handling stacking, the stacking bus cycle (write) is executed. In stacking of the status register (SR) and program counter (PC), the SP is decremented by 4 for both, so the value of SP will not be a multiple of four after the stacking either. The address value output during stacking is the SP value, so the address where the error occurred is itself output. This means that the write data stacked will be undefined.

4.8.4 Manual Reset during Register Access

Do not initiate a manual reset during access of a bus state controller (BSC), user break controller (UBC), or pin function controller (PFC) register, or the frequency modification register (FMR), otherwise a write error may result.

Section 5 Interrupt Controller (INTC)

5.1 Overview

The interrupt controller (INTC) ascertains the priority order of interrupt sources and controls interrupt requests to the CPU. The INTC has registers for setting the priority of each interrupt which allow the user to set the order of priority in which interrupt requests are handled.

5.1.1 Features

The INTC has the following features:

- Sixteen interrupt priority levels can be set
By setting the five interrupt priority registers, the priorities of on-chip peripheral module interrupts can be selected at 16 levels for different request sources.
- Vector numbers for on-chip peripheral module interrupt can be set
By setting the 24 vector number setting registers, the vector numbers of on-chip peripheral module interrupts can be set to values from 0 to 127 for different request sources.
- The IRL interrupt vector number setting method can be selected: Either of two modes can be selected by a register setting: auto-vector mode in which vector numbers are determined internally, and external vector mode in which vector numbers are set externally.
- IRQ interrupt settings can be made (low level, rising-, falling-, or both-edge detection)

5.1.2 Block Diagram

Figure 5.1 shows a block diagram of the INTC.

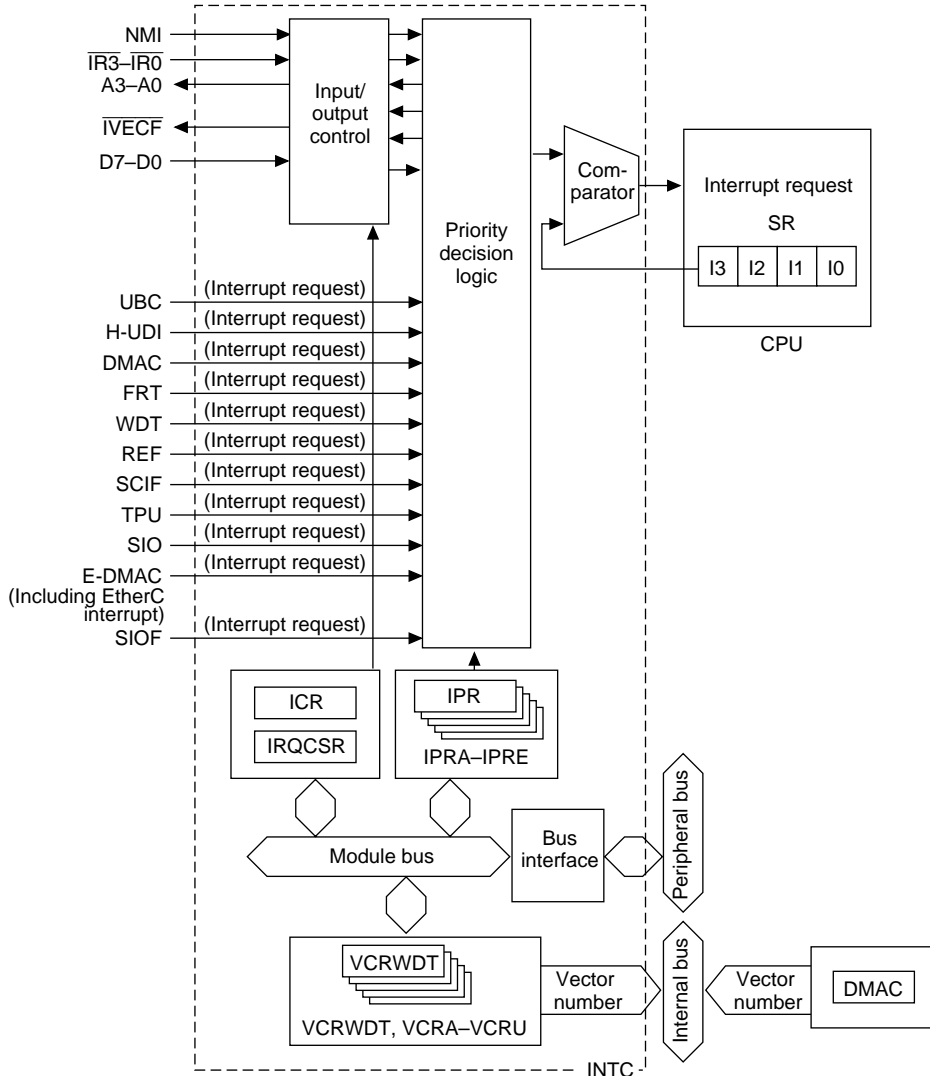

- | | | | |
|--------|---|------------|---|
| UBC: | User break controller | E-DMAC: | Ethernet controller direct memory access controller |
| H-UDI: | Hitachi user debug interface | EtherC: | Ethernet controller |
| DMAC: | Direct memory access controller | ICR: | Interrupt control register |
| FRT: | 16-bit free-running timer | IRQCSR: | IRQ control/status register |
| WDT: | Watchdog timer | IPRA-IPRE: | Interrupt priority level setting registers A-E |
| REF: | Refresh request within bus state controller | VCRWDT: | Vector number setting register WDT |
| SCIF: | Serial communication interface with FIFO | VCRA-VCRU: | Vector number setting registers A-U |
| TPU: | 16-bit timer pulse unit | SR: | Status register |
| SIO: | Serial I/O | | |
| SIOF: | Serial I/O with FIFO | | |

Figure 5.1 INTC Block Diagram

5.1.3 Pin Configuration

Table 5.1 shows the INTC pin configuration.

Table 5.1 Pin Configuration

Name	Abbreviation	I/O	Function
Nonmaskable interrupt input pin	NMI	I	Input of nonmaskable interrupt request signal
Level request interrupt input pins	$\overline{\text{IRL3}}\text{--}\overline{\text{IRL0}}$	I	Input of maskable interrupt request signals
Interrupt acceptance level output pins	A3–A0	O	In external vector mode, output an interrupt level signal when an IRL/IRQ interrupt is accepted
External vector fetch pin	$\overline{\text{IVECF}}$	O	Indicates external vector read cycle
External vector number input pins	D7–D0	I	Input external vector number

5.1.4 Register Configuration

The INTC has the 31 registers shown in table 5.2. These registers perform various INTC functions including setting interrupt priority, and controlling external interrupt input signal detection.

Table 5.2 Register Configuration

Name	Abbr.	R/W	Initial Value	Address	Access Size
Interrupt priority register setting register A	IPRA	R/W	H'0000	H'FFFFFFE2	8, 16
Interrupt priority register setting register B	IPRB	R/W	H'0000	H'FFFFFFE6	8, 16
Interrupt priority register setting register C	IPRC	R/W	H'0000	H'FFFFFFE6	8, 16
Interrupt priority register setting register D	IPRD	R/W	H'0000	H'FFFFFFE4	8, 16
Interrupt priority register setting register E	IPRE	R/W	H'0000	H'FFFFFFE0	8, 16
Vector number setting register A	VCRA	R/W	H'0000	H'FFFFFFE2	8, 16
Vector number setting register B* ³	VCRB	R/W	H'0000	H'FFFFFFE4	8, 16
Vector number setting register C	VCRC	R/W	H'0000	H'FFFFFFE6	8, 16
Vector number setting register D	VCRD	R/W	H'0000	H'FFFFFFE8	8, 16
Vector number setting register E	VCRE	R/W	H'0000	H'FFFFFFE2	8, 16
Vector number setting register F	VCRF	R/W	H'0000	H'FFFFFFE4	8, 16
Vector number setting register G	VCRG	R/W	H'0000	H'FFFFFFE6	8, 16

Table 5.2 Register Configuration (cont)

Name	Abbr.	R/W	Initial Value	Address	Access Size
Vector number setting register H	VCRH	R/W	H'0000	H'FFFFFFE48	8, 16
Vector number setting register I	VCRI	R/W	H'0000	H'FFFFFFE4A	8, 16
Vector number setting register J	VCRJ	R/W	H'0000	H'FFFFFFE4C	8, 16
Vector number setting register K	VCRK	R/W	H'0000	H'FFFFFFE4E	8, 16
Vector number setting register L	VCRL	R/W	H'0000	H'FFFFFFE50	8, 16
Vector number setting register M	VCRM	R/W	H'0000	H'FFFFFFE52	8, 16
Vector number setting register N	VCRN	R/W	H'0000	H'FFFFFFE54	8, 16
Vector number setting register O	VCRO	R/W	H'0000	H'FFFFFFE56	8, 16
Vector number setting register P	VCRP	R/W	H'0000	H'FFFFFFEC2	8, 16
Vector number setting register Q	VCRQ	R/W	H'0000	H'FFFFFFEC4	8, 16
Vector number setting register R	VCRR	R/W	H'0000	H'FFFFFFEC6	8, 16
Vector number setting register S	VCRS	R/W	H'0000	H'FFFFFFEC8	8, 16
Vector number setting register T	VCRT	R/W	H'0000	H'FFFFFFECA	8, 16
Vector number setting register U	VCRU	R/W	H'0000	H'FFFFFFECC	8, 16
Vector number setting register WDT	VCRWDT	R/W	H'0000	H'FFFFFFEE4	8, 16
Vector number setting register DMA0* ⁴	VCRDMA0	R/W	Undefined	H'FFFFFFFA0	32
Vector number setting register DMA1* ⁴	VCRDMA1	R/W	Undefined	H'FFFFFFFA8	32
Interrupt control register	ICR	R/W	H'8000/ H'0000* ¹	H'FFFFFFEE0	8, 16
IRQ control/status register	IRQCSR	R/W	* ²	H'FFFFFFEE8	8, 16

Notes: *1 The value when the NMI pin is high is H'8000; when the NMI pin is low, it is H'0000.

*2 When pins $\overline{IRL3}$ – $\overline{IRL0}$ are high, bits 7–4 in IRQCSR are set to 1. When pins $\overline{IRL3}$ – $\overline{IRL0}$ are low, bits 7–4 in IRQCSR are cleared to 0. The initial value of bits other than 7–4 is 0.

*3 In the SH7616, VCRB is a reserved register and must not be accessed.

*4 See section 11, Direct Memory Access Controller for more information on VCRDMA0, and VCRDMA1.

5.2 Interrupt Sources

There are five types of interrupt sources: NMI, user breaks, H-UDI, IRL/IRQ and on-chip peripheral modules. Each interrupt has a priority expressed as a priority level (0 to 16, with 0 the lowest and 16 the highest). Giving an interrupt a priority level of 0 masks it.

5.2.1 NMI Interrupt

The NMI interrupt has priority 16 and is always accepted. Input at the NMI pin is detected by edge. Use the NMI edge select bit (NMIE) in the interrupt control register (ICR) to select either the rising or falling edge. NMI interrupt exception handling sets the interrupt mask level bits (I3–I0) in the status register (SR) to level 15.

5.2.2 User Break Interrupt

A user break interrupt has priority level 15 and occurs when the break condition set in the user break controller (UBC) is satisfied. User break interrupt exception handling sets the interrupt mask level bits (I3–I0) in the status register (SR) to level 15. For more information about the user break interrupt, see section 6, User Break Controller.

5.2.3 H-UDI Interrupt

The H-UDI interrupt has a priority level of 15, and is generated when an H-UDI interrupt instruction is serially input. H-UDI interrupt exception processing sets the interrupt mask bits (I3–I0) in the status register (SR) to level 15. See section 18, Hitachi User Debug Interface, for details of the H-UDI interrupt.

5.2.4 IRL Interrupts

IRL interrupts are requested by input from pins $\overline{\text{IRL3}}\text{--}\overline{\text{IRL0}}$. Fifteen interrupts, IRL15–IRL1, can be input externally via pins $\overline{\text{IRL3}}\text{--}\overline{\text{IRL0}}$. The priority levels of interrupts IRL15–IRL0 are 15–1, respectively, and their vector numbers are 71–64. Set the vector numbers with the interrupt vector mode select (VECMD) bit of the interrupt control register (ICR) to enable external input. External input of vector numbers consists of vector numbers 0–127 from the external vector input pins (D7–D0). When an external vector is used, 0 is input to D7. Internal vectors are called auto-vectors and vectors input externally are called external vectors. Table 5.3 lists IRL priority levels and auto vector numbers.

When an IRL interrupt is accepted in external vector mode, the IRL interrupt level is output from the interrupt acceptance level output pins (A3–A0). The external vector fetch pin ($\overline{\text{IVECF}}$) is also asserted. The external vector number is read from pins D7–D0 at this time.

IRL interrupt exception processing sets the interrupt mask level bits (I3 to I0) in the status register (SR) to the priority level value of the IRL interrupt that was accepted.

5.2.5 IRQ Interrupts

An IRQ interrupt is requested when the external interrupt vector mode select bit (EXIMD) of the interrupt control register (ICR) is set to 1. An IRQ interrupt corresponds to input at one of pins $\overline{IRL3}$ – $\overline{IRL0}$. Low-level sensing or rising/falling/both-edge sensing can be selected independently for each pin by the IRQ sense select bits (IRQ31S–IRQ00S) in the IRQ control/status register (IRQCSR), and a priority level of 0 to 15 can be selected independently for each pin by means of interrupt priority register C (IPRC). Set the interrupt vector mode select bit (VECMD) of the interrupt control register (ICR) to enable external input of vector numbers. External vector numbers are 0 to 127, and are input to the external vector input pins (D7–D0) during the interrupt vector fetch bus cycle. When an external vector is used, 0 is input to D7.

When an IRQ interrupt is accepted in external vector mode, the IRQ interrupt priority level is output from the interrupt acceptance level output pins (A3–A0). The external vector fetch signal (\overline{IVECF}) is also asserted. The external vector number is read from signals D7–D0 at this time.

IRQ interrupt exception processing sets the interrupt mask bits (I3–I0) in the status register (SR) to the priority level value of the IRQ interrupt that was accepted.

Table 5.3 IRL Interrupt Priority Levels and Auto-Vector Numbers

Pin				Priority Level	Vector Number
$\overline{IRL3}$	$\overline{IRL2}$	$\overline{IRL1}$	$\overline{IRL0}$		
0	0	0	0	15	71
			1	14	
		1	0	13	70
			1	12	
	1	0	0	11	69
			1	10	
		1	0	9	68
			1	8	
1	0	0	0	7	67
			1	6	
		1	0	5	66
			1	4	
	1	0	0	3	65
			1	2	
		1	0	1	64
			1	0	

An example of connections for external vector mode interrupts is shown in figure 5.2, and an example of connections for auto-vector mode interrupts in figure 5.3.

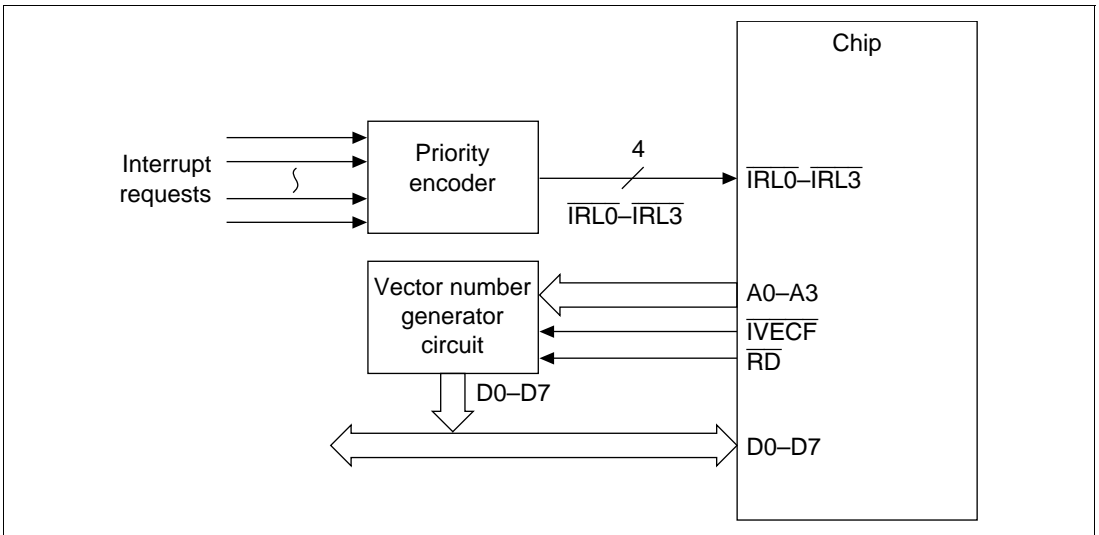

Figure 5.2 Example of Connections for External Vector Mode Interrupts

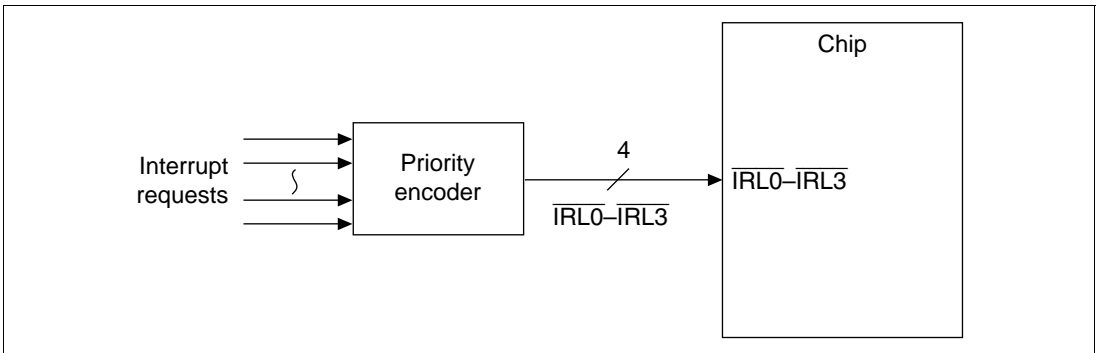

Figure 5.3 Example of Connections for Auto-Vector Mode Interrupts

Figures 5.4 to 5.7 show the interrupt vector fetch cycle for the external vector mode. During this cycle, $\overline{CS0}$ – $\overline{CS4}$ stay high. A24–A4 output undefined values. The \overline{WAIT} pin is sampled, but programmable waits are not valid.

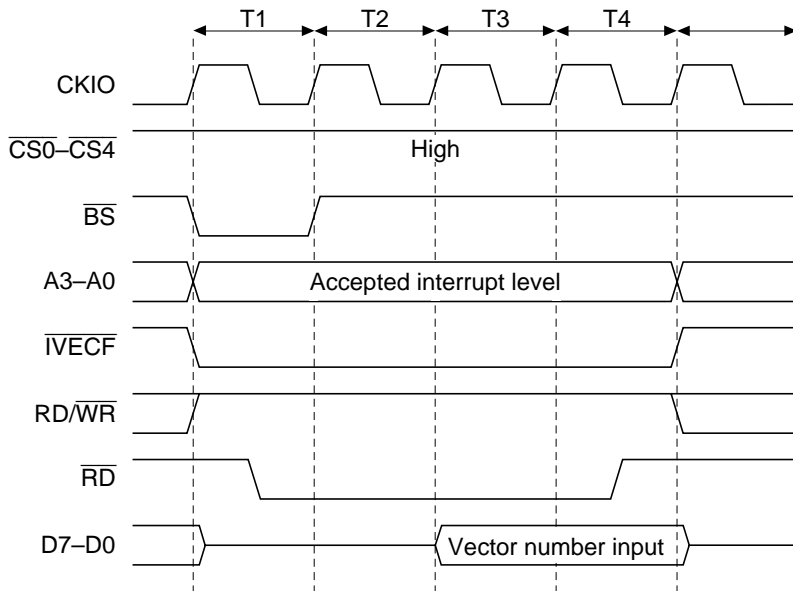

Figure 5.4 External Vector Fetch ($I\phi : E\phi = 1 : 1$)

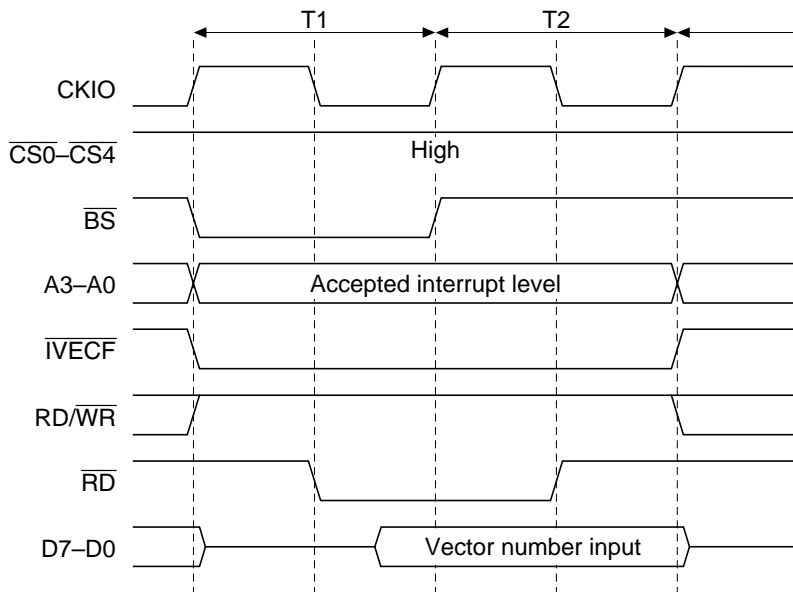

Figure 5.5 External Vector Fetch ($I\phi : E\phi \neq 1 : 1$)

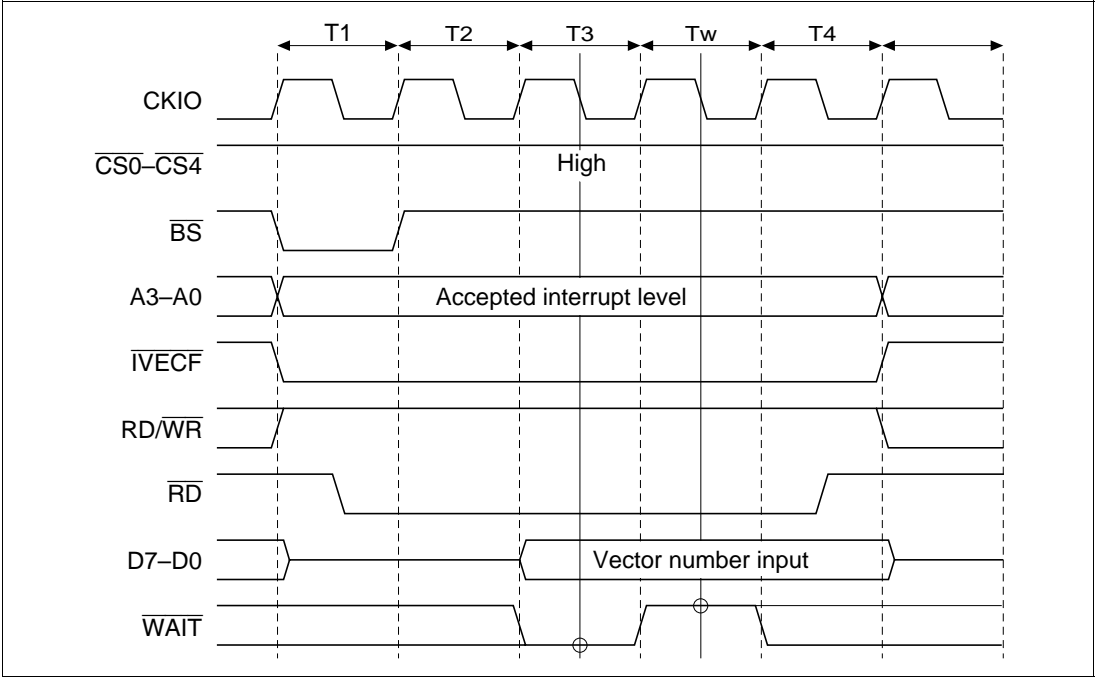

Figure 5.6 External Vector Fetch ($I\phi : E\phi = 1 : 1$) ($\overline{\text{WAIT}}$ Input)

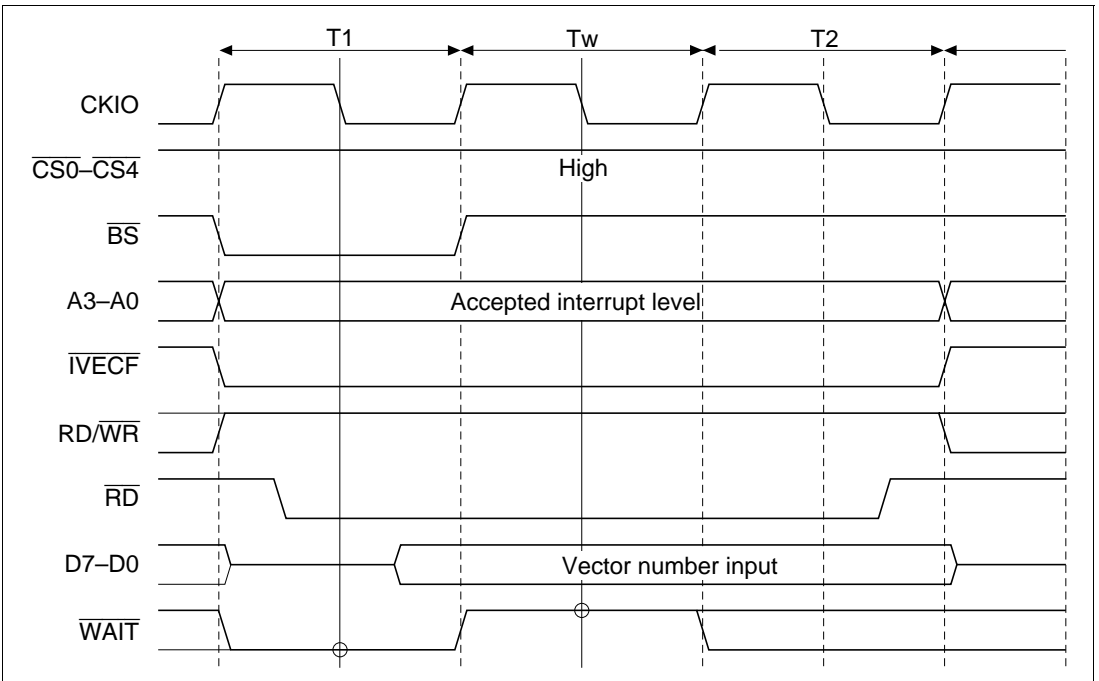

Figure 5.7 External Vector Fetch ($I\phi : E\phi \neq 1 : 1$) ($\overline{\text{WAIT}}$ Input)

5.2.6 On-chip Peripheral Module Interrupts

On-chip peripheral module interrupts are interrupts generated by the following 9 on-chip peripheral modules:

- Direct memory access controller (DMAC)
- Bus state controller (BSC)
- Watchdog timer (WDT)
- 16-bit free-running timer (FRT)
- Ethernet controller direct memory access controller (E-DMAC) (Including EtherC interrupt)
- 16-bit timer pulse unit (TPU)
- Serial communication interface with FIFO (SCIF)
- Serial I/O with FIFO (SIOF)
- Serial I/O (SIO)

A different interrupt vector is assigned to each interrupt source, so the exception service routine does not have to decide which interrupt has occurred. Priority levels between 0 and 15 can be assigned to individual on-chip peripheral modules in interrupt priority registers A, B, D, and E (IPRA, IPRB, IPRD, IPRE). On-chip peripheral module interrupt exception handling sets the interrupt mask level bits (I3–I0) in the status register (SR) to the priority level value of the on-chip peripheral module interrupt that was accepted.

5.2.7 Interrupt Exception Vectors and Priority Order

Table 5.4 lists interrupt sources and their vector numbers, vector table address offsets and interrupt priorities.

Each interrupt source is allocated a different vector number and vector table address offset. Vector table addresses are calculated from vector numbers and vector table address offsets. In interrupt exception handling, the exception service routine start address is fetched from the vector table entry indicated by the vector table address. See table 4.4, Calculating Exception Vector Table Addresses, in section 4, Exception Handling, for more information on this calculation.

IRL interrupts IRL15–IRL1 have interrupt priority levels of 15–1, respectively. IRQ interrupt and on-chip peripheral module interrupt priorities can be set freely between 0 and 15 for each module by setting interrupt priority registers A–E (IPRA–IPRE). The ranking of interrupt sources for IPRA–IPRE, however, must be the order listed under Priority within IPR Setting Unit in table 5.4 and cannot be changed. A reset assigns priority level 0 to on-chip peripheral module interrupts. If the same priority level is assigned to two or more interrupt sources and interrupts from those sources occur simultaneously, their priority order is the default priority order indicated at the right in table 5.4.

Table 5.4 (a) Interrupt Exception Vectors and Priority Order (IRL Mode)

Interrupt Source	Vectors		Interrupt Priority		Priority within IPR		Default Priority
	Vector No.	Vector Table Address	Order (Initial Value)	IPR (Bit Numbers)	Setting Unit	VCR (Bit Numbers)	
NMI	11	VBR +	16	—	—	—	High
User break	12	(vector No.	15	—	—	—	↑
H-UDI	13	× 4)	15	—	—	—	
IRL15* ⁴	71* ¹		15	—	—	—	
IRL14* ⁴			14	—	—	—	
IRL13* ⁴	70* ¹		13	—	—	—	
IRL12* ⁴			12	—	—	—	
IRL11* ⁴	69* ¹		11	—	—	—	
IRL10* ⁴			10	—	—	—	
IRL9* ⁴	68* ¹		9	—	—	—	
IRL8* ⁴			8	—	—	—	
IRL7* ⁴	67* ¹		7	—	—	—	
IRL6* ⁴			6	—	—	—	
IRL5* ⁴	66* ¹		5	—	—	—	
IRL4* ⁴			4	—	—	—	
IRL3* ⁴	65* ¹		3	—	—	—	
IRL2* ⁴			2	—	—	—	
IRL1* ⁴	64* ¹		1	—	—	—	
DMAC0	Transfer end	0–127* ²	15–0 (0)	IPRA (11–8)	High ↑ Low ↓	VCRDMA0 (6–0)	
DMAC1	Transfer end	0–127* ²	15–0 (0)		High ↑ Low ↓	VCRDMA1 (6–0)	↓ Low

Table 5.4 (a) Interrupt Exception Vectors and Priority Order (IRL Mode) (cont)

Interrupt Source		Vectors		Interrupt Priority Order (Initial Value)	IPR (Bit Numbers)	Priority within IPR Setting Unit	VCR (Bit Numbers)	Default Priority	
		Vector No.	Vector Table Address						
WDT	ITI	0-127* ²	VBR + (vector No. × 4)	15-0 (0)	IPRA (7-4)	High	VCRWDT (14-8)	High ↑	
						↓			
						Low			
REF* ³	CMI	0-127* ²		15-0 (0)		High	VCRWDT (6-0)	↑	
						↓			
						Low			
E-DMAC	EINT* ⁶	0-127* ²		15-0 (0)	IPRB (15-12)	High	VCRA (14-8)	↑	
Reserved						↓	VCRB (14-0)* ⁵		
						Low			
FRT	ICI	0-127* ²		15-0 (0)	IPRB (11-8)	High	VCRC (14-8)	↑	
	OCI	0-127* ²				↓	VCRC (6-0)		
	OVI	0-127* ²				↓	VCRD (14-8)		
						Low			
TPU0	TGI0A	0-127* ²		15-0 (0)	IPRD (15-12)	High	VCRE (14-8)	↑	
	TGI0B	0-127* ²				↓	VCRE (6-0)		
	TGI0C	0-127* ²				↓	VCRF (14-8)		
	TGI0D	0-127* ²				↓	VCRF (6-0)		
	TCI0V	0-127* ²				Low	VCRG (14-8)		
TPU1	TGI1A	0-127* ²		15-0 (0)	IPRD (11-8)	High	VCRH (14-8)	↑	
	TGI1B	0-127* ²				↓	VCRH (6-0)		
	TCI1V	0-127* ²				↓	VCRI (14-8)		
	TCI1U	0-127* ²				Low	VCRI (6-0)		
TPU2	TGI2A	0-127* ²		15-0 (0)	IPRD (7-4)	High	VCRJ (14-8)	↑	
	TGI2B	0-127* ²				↓	VCRJ (6-0)		
	TCI2V	0-127* ²				↓	VCRK (14-8)		↓
	TCI2U	0-127* ²				Low	VCRK (6-0)		Low

Table 5.4 (a) Interrupt Exception Vectors and Priority Order (IRL Mode) (cont)

Interrupt Source		Vectors		Interrupt Priority		Priority within IPR		Default Priority
		Vector No.	Vector Table Address	Order (Initial Value)	IPR (Bit Numbers)	Setting Unit	VCR (Bit Numbers)	
SCIF1	ERI1	0-127* ²	VBR + (vector No. × 4)	15-0 (0)	IPRD (3-0)	High	VCRL (14-8)	High ↑
	RX11	0-127* ²				↑	VCRL (6-0)	
	BRI1	0-127* ²				↓	VCRM (14-8)	
	TX11	0-127* ²				Low	VCRM (6-0)	
SCIF2	ERI2	0-127* ²		15-0 (0)	IPRE (15-12)	High	VCRN (14-8)	
	RX12	0-127* ²				↑	VCRN (6-0)	
	BRI2	0-127* ²				↓	VCRO (14-8)	
	TX12	0-127* ²				Low	VCRO (6-0)	
SIOF	RERI0	0-127* ²		15-0 (0)	IPRE (11-8)	High	VCRP (14-8)	
	TERI0	0-127* ²				↑	VCRP (6-0)	
	RDFI0	0-127* ²				↓	VCRQ (14-8)	
	TDEI0	0-127* ²				Low	VCRQ (6-0)	
SIO1	RERI1	0-127* ²		15-0 (0)	IPRE (7-4)	High	VCRR (14-8)	
	TERI1	0-127* ²				↑	VCRR (6-0)	
	RDFI1	0-127* ²				↓	VCRS (14-8)	
	TDEI1	0-127* ²				Low	VCRS (6-0)	
SIO2	RERI2	0-127* ²		15-0 (0)	IPRE (3-0)	High	VCRT (14-8)	
	TERI2	0-127* ²				↑	VCRT (6-0)	
	RDFI2	0-127* ²				↓	VCRU (14-8)	
	TDEI2	0-127* ²				Low	VCRU (6-0)	
Reserved		128-255	—	—	—	—	—	Low

Notes: *1 An external vector number fetch can be performed without using the auto-vector numbers shown in this table. The external vector numbers are 0-127.

*2 Vector numbers are set in the on-chip vector number register.

*3 REF is the refresh control unit within the bus state controller.

*4 Set to IRL1-IRL15 or IRQ0-IRQ3 by the EXIMD bit in ICR.

*5 In the SH7616, VCRB is a reserved register and must not be accessed.

*6 The E-DMAC interrupt (EINT) is the OR of those of the 19 interrupt sources in the EtherC/E-DMAC status register (EESR) that are enabled by the EtherC/E-DMAC status interrupt permission register (EESIPR). As the three status bits in the EtherC status register (ECSR) can be copied into the ECI bit in EESR as an interrupt source, EINT is input to the INTC as the OR of a maximum of 22 interrupt sources.

Table 5.4 (b) Interrupt Exception Vectors and Priority Order (IRQ Mode)

Interrupt Source	Vectors		Interrupt Priority Order (Initial Value)	Priority within IPR			Default Priority
	Vector No.	Vector Table Address		Setting Unit	VCR (Bit Numbers)		
NMI	11	VBR +	16	—	—	—	High ↑
User break	12	(vector No.	15	—	—	—	
H-UDI	13	× 4)	15	—	—	—	
IRQ0* ⁴	64* ¹		15-0 (0)	IPRC (15-12)	—	—	
IRQ1* ⁴	65* ¹		15-0 (0)	IPRC (11-8)	—	—	
IRQ2* ⁴	66* ¹		15-0 (0)	IPRC (7-4)	—	—	
IRQ3* ⁴	67* ¹		15-0 (0)	IPRC (3-0)	—	—	
DMAC0	Transfer end	0-127* ²	15-0 (0)	IPRA (11-8)	High ↑ ↓ Low	VCRDMA0 (6-0)	
DMAC1	Transfer end	0-127* ²	15-0 (0)		High ↑ ↓ Low	VCRDMA1 (6-0)	
WDT	ITI	0-127* ²	15-0 (0)	IPRA (7-4)	High ↑ ↓ Low	VCRWDT (14-8)	
REF* ³	CMI	0-127* ²	15-0 (0)		High ↑ ↓ Low	VCRWDT (6-0)	↓ Low

Table 5.4 (b) Interrupt Exception Vectors and Priority Order (IRQ Mode) (cont)

			Vectors	Interrupt Priority		Priority within			
Interrupt Source			Vector No.	Vector Table Address	Order (Initial Value)	IPR (Bit Numbers)	Setting Unit	VCR (Bit Numbers)	Default Priority
E-DMAC	EINT* ⁶	0-127* ²	VBR + (vector No. × 4)	15-0 (0)	IPRB (15-12)	High ↑	VCRA (14-8)	High ↑	
Reserved									Low ↓
FRT	ICI	0-127* ²		15-0 (0)	IPRB (11-8)	High ↑	VCRC (14-8)		
	OCIA/B	0-127* ²							VCRC (6-0)
	OVI	0-127* ²							VCRC (14-8) Low ↓
TPU0	TGI0A	0-127* ²		15-0 (0)	IPRD (15-12)	High ↑	VCRE (14-8)		
	TGI0B	0-127* ²							VCRE (6-0)
	TGI0C	0-127* ²							VCRF (14-8)
	TGI0D	0-127* ²							VCRF (6-0) Low ↓
	TCI0V	0-127* ²							VCRG (14-8)
TPU1	TGI1A	0-127* ²		15-0 (0)	IPRD (11-8)	High ↑	VCRH (14-8)		
	TGI1B	0-127* ²							VCRH (6-0)
	TCI1V	0-127* ²							VCRI (14-8)
	TCI1U	0-127* ²							VCRI (6-0) Low ↓
TPU2	TGI2A	0-127* ²		15-0 (0)	IPRD (7-4)	High ↑	VCRJ (14-8)		
	TGI2B	0-127* ²							VCRJ (6-0)
	TCI2V	0-127* ²							VCRK (14-8)
	TCI2U	0-127* ²							VCRK (6-0) Low ↓
SCIF1	ERI1	0-127* ²		15-0 (0)	IPRD (3-0)	High ↑	VCRL (14-8)		
	RXI1	0-127* ²							VCRL (6-0)
	BRI1	0-127* ²							VCRM (14-8)
	TXI1	0-127* ²							VCRM (6-0) Low ↓
SCIF2	ERI2	0-127* ²		15-0 (0)	IPRE (15-12)	High ↑	VCRN (14-8)		
	RXI2	0-127* ²							VCRN (6-0)
	BRI2	0-127* ²							VCRO (14-8)
	TXI2	0-127* ²							VCRO (6-0) Low ↓

Table 5.4 (b) Interrupt Exception Vectors and Priority Order (IRQ Mode) (cont)

Interrupt Source	Vectors		Interrupt Priority Order (Initial Value)	IPR (Bit Numbers)	Priority within IPR Setting Unit	VCR (Bit Numbers)	Default Priority	
	Vector No.	Vector Table Address						
SIOF	RERI0	0–127* ²	VBR + (vector No. × 4)	15–0 (0)	IPRE (11–8)	High	High	
	TERI0	0–127* ²						VCRP (14–8)
	RDFI0	0–127* ²						VCRP (6–0)
	TDEI0	0–127* ²						VCRQ (14–8)
SIO1	RERI1	0–127* ²		15–0 (0)	IPRE (7–4)	High		
	TERI1	0–127* ²						VCRQ (6–0)
	RDFI1	0–127* ²						VCRR (14–8)
	TDEI1	0–127* ²						VCRR (6–0)
SIO2	RERI2	0–127* ²		15–0 (0)	IPRE (3–0)	High		
	TERI2	0–127* ²						VCRT (14–8)
	RDFI2	0–127* ²						VCRT (6–0)
	TDEI2	0–127* ²						VCRU (14–8)
Reserved	128–255	—	—	—	—	—	Low	

Notes: *1 An external vector number fetch can be performed without using the auto-vector numbers shown in this table. The external vector numbers are 0–127.

*2 Vector numbers are set in the on-chip vector number register.

*3 REF is the refresh control unit within the bus state controller.

*4 Set to IRL1–IRL15 or IRQ0–IRQ3 by the EXIMD bit in ICR.

*5 In the SH7616, VCRB is a reserved register and must not be accessed.

*6 The E-DMAC interrupt (EINT) is the OR of those of the 19 interrupt sources in the EtherC/E-DMAC status register (EESR) that are enabled by the EtherC/E-DMAC status interrupt permission register (EESIPR). As the three status bits in the EtherC status register (ECSR) can be copied into the ECI bit in EESR as an interrupt source, EINT is input to the INTC as the OR of a maximum of 22 interrupt sources.

5.3 Register Descriptions

5.3.1 Interrupt Priority Level Setting Register A (IPRA)

Interrupt priority level setting register A (IPRA) is a 16-bit read/write register that assigns priority levels from 0 to 15 to on-chip peripheral module interrupts. IPRA is initialized to H'0000 by a reset. It is not initialized in standby mode. Unless otherwise specified, 'reset' refers to both power-on and manual resets throughout this manual.

Bit:	15	14	13	12	11	10	9	8
	—	—	—	—	DMAC IP3	DMAC IP2	DMAC IP1	DMAC IP0
Initial value:	0	0	0	0	0	0	0	0
R/W:	R	R	R	R	R/W	R/W	R/W	R/W

Bit:	7	6	5	4	3	2	1	0
	WDT IP3	WDT IP2	WDT IP1	WDT IP0	—	—	—	—
Initial value:	0	0	0	0	0	0	0	0
R/W:	R/W	R/W	R/W	R/W	R	R	R	R

Bits 15 to 12—Reserved: These bits are always read as 0. The write value should always be 0.

Bits 11 to 8—Direct Memory Access Controller (DMAC) Interrupt Priority Level 3 to 0 (DMACIP3–DMACIP0): These bits set the direct memory access controller (DMAC) interrupt priority level. There are four bits, so levels 0–15 can be set. The same level is set for both two DMAC channels. When interrupts occur simultaneously, channel 0 has priority.

Bits 7 to 4—Watchdog Timer (WDT) Interrupt Priority Level 3 to 0 (WDTIP3–WDTIP0): These bits set the watchdog timer (WDT) interrupt priority level and bus state controller (BSC) interrupt priority level. There are four bits, so levels 0–15 can be set. When WDT and BSC interrupts occur simultaneously, the WDT interrupt has priority.

Bits 3 to 0—Reserved: These bits are always read as 0. The write value should always be 0.

5.3.2 Interrupt Priority Level Setting Register B (IPRB)

Interrupt priority level setting register B (IPRB) is a 16-bit read/write register that assigns priority levels from 0 to 15 to on-chip peripheral module interrupts. IPRB is initialized to H'0000 by a reset. It is not initialized in standby mode.

Bit:	15	14	13	12	11	10	9	8
	E-DMAC IP3	E-DMAC IP2	E-DMAC IP1	E-DMAC IP0	FRTIP3	FRTIP2	FRTIP1	FRTIP0
Initial value:	0	0	0	0	0	0	0	0
R/W:	R/W	R/W	R/W	R/W	R/W	R/W	R/W	R/W
Bit:	7	6	5	4	3	2	1	0
	—	—	—	—	—	—	—	—
Initial value:	0	0	0	0	0	0	0	0
R/W:	R	R	R	R	R	R	R	R

Bits 15 to 12—Ethernet Controller Direct Memory Access Controller (E-DMAC) Interrupt Priority Level 3 to 0 (E-DMACIP3–E-DMACIP0): These bits set the ethernet controller direct memory access controller (E-DMAC) interrupt priority level. There are four bits, so levels 0–15 can be set.

Bits 11 to 8—16-Bit Free-Running Timer (FRT) Interrupt Priority Level 3 to 0 (FRTIP3–FRTIP0): These bits set the 16-bit free-running timer (FRT) interrupt priority level. There are four bits, so levels 0–15 can be set.

Bits 7 to 0—Reserved: These bits are always read as 0. The write value should always be 0.

5.3.3 Interrupt Priority Level Setting Register C (IPRC)

Interrupt priority level setting register C (IPRC) is a 16-bit read/write register that sets the priority levels (0–15) of IRQ0–IRQ3 interrupts. IPRC is initialized to H'0000 by a reset. It is not initialized in standby mode.

Bit:	15	14	13	12	11	10	9	8
	IRQ0IP3	IRQ0IP2	IRQ0IP1	IRQ0IP0	IRQ1IP3	IRQ1IP2	IRQ1IP1	IRQ1IP0
Initial value:	0	0	0	0	0	0	0	0
R/W:	R/W	R/W	R/W	R/W	R/W	R/W	R/W	R/W

Bit:	7	6	5	4	3	2	1	0
	IRQ2IP3	IRQ2IP2	IRQ2IP1	IRQ2IP0	IRQ3IP3	IRQ3IP2	IRQ3IP1	IRQ3IP0
Initial value:	0	0	0	0	0	0	0	0
R/W:	R/W	R/W	R/W	R/W	R/W	R/W	R/W	R/W

Bits 15 to 0–IRQ0 to IRQ3 Priority Level 3 to 0 (IRQnIP3–IRQnIP0, n = 0–3): These bits set the IRQ0–IRQ3 priority levels. There are four bits for each interrupt, so the value can be set between 0 and 15.

5.3.4 Interrupt Priority Level Setting Register D (IPRD)

Interrupt priority level setting register D (IPRD) is a 16-bit read/write register that sets the priority levels (0–15) of on-chip peripheral module interrupts. IPRD is initialized to H'0000 by a reset. It is not initialized in standby mode.

Bit:	15	14	13	12	11	10	9	8
	TPU0IP3	TPU0IP2	TPU0IP1	TPU0IP0	TPU1IP3	TPU1IP2	TPU1IP1	TPU1IP0
Initial value:	0	0	0	0	0	0	0	0
R/W:	R/W	R/W	R/W	R/W	R/W	R/W	R/W	R/W

Bit:	7	6	5	4	3	2	1	0
	TPU2IP3	TPU2IP2	TPU2IP1	TPU2IP0	SCF1IP3	SCF1IP2	SCF1IP1	SCF1IP0
Initial value:	0	0	0	0	0	0	0	0
R/W:	R/W	R/W	R/W	R/W	R/W	R/W	R/W	R/W

Bits 15 to 4—16-Bit Timer Pulse Unit 0 to 2 (TPU0–TPU2) Interrupt Priority Level 3 to 0 (TPUnIP3–TPUnIP0, n = 0–2): These bits set the 16-bit timer pulse unit 0 to 2 (TPU0–TPU2) interrupt priority levels. There are four bits for each interrupt, so the value can be set between 0 and 15.

Bits 3 to 0—Serial Communication Interface with FIFO 1 (SCIF1) Interrupt Priority Level 3 to 0 (SCF1IP3–SCF1IP0): These bits set the serial communication interface with FIFO 1 (SCIF1) interrupt priority level. There are four bits, so the value can be set between 0 and 15.

5.3.5 Interrupt Priority Level Setting Register E (IPRE)

Interrupt priority level setting register E (IPRE) is a 16-bit read/write register that sets the priority levels (0–15) of on-chip peripheral module interrupts. IPRE is initialized to H'0000 by a reset. It is not initialized in standby mode.

Bit:	15	14	13	12	11	10	9	8
	SCF2IP3	SCF2IP2	SCF2IP1	SCF2IP0	SIOFIP3	SIOFIP2	SIOFIP1	SIOFIP0
Initial value:	0	0	0	0	0	0	0	0
R/W:	R/W	R/W	R/W	R/W	R/W	R/W	R/W	R/W

Bit:	7	6	5	4	3	2	1	0
	SIO1IP3	SIO1IP2	SIO1IP1	SIO1IP0	SIO2IP3	SIO2IP2	SIO2IP1	SIO2IP0
Initial value:	0	0	0	0	0	0	0	0
R/W:	R/W	R/W	R/W	R/W	R/W	R/W	R/W	R/W

Bits 15 to 12—Serial Communication Interface with FIFO 2 (SCIF2) Interrupt Priority Level 3 to 0 (SCF2IP3–SCF2IP0): These bits set the serial communication interface with FIFO 2 (SCIF2) interrupt priority levels. There are four bits, so the value can be set between 0 and 15.

Bits 11 to 8—Serial I/O with FIFO (SIOF) Interrupt Priority Level 3 to 0 (SIOFIP3(SIOFIP0): These bits set the serial I/O with FIFO (SIOF) interrupt priority levels. There are four bits, so the value can be set between 0 and 15.

Bits 7 to 0—Serial I/O 1 to 2 (SIO1–SIO2) Interrupt Priority Level 3 to 0 (SIO1IP3–SIO1IP0, n = 0–2): These bits set the serial I/O 0 to 2 (SIO0–SIO2) interrupt priority levels. There are four bits for each interrupt, so the value can be set between 0 and 15.

Table 5.5 shows the relationship between on-chip peripheral module interrupts and interrupt priority level setting registers.

Table 5.5 Interrupt Request Sources and IPRA–IPRE

Register	Bits 15 to 12	Bits 11 to 8	Bits 7 to 4	Bits 3 to 0
Interrupt priority level setting register A	Reserved	DMAC0, DMAC1	WDT, REF	Reserved
Interrupt priority level setting register B	E-DMAC	FRT	Reserved	Reserved
Interrupt priority level setting register C	IRQ0	IRQ1	IRQ2	IRQ3
Interrupt priority level setting register D	TPU0	TPU1	TPU2	SCIF1
Interrupt priority level setting register E	SCIF2	SIOF	SIO1	SIO2

As table 5.5 shows, between two and four on-chip peripheral modules are assigned to each interrupt priority level setting register. Set the priority levels by setting the corresponding 4-bit groups with values in the range of H'0 (0000) to H'F (1111). H'0 is interrupt priority level 0 (the lowest); H'F is level 15 (the highest). When two on-chip peripheral modules are assigned to the same bits (DMAC0 and DMAC1, or WDT and BSC refresh control unit), those two modules have the same priority. A reset initializes IPRA–IPRE to H'0000. They are not initialized in standby mode.

5.3.6 Vector Number Setting Register WDT (VCRWDT)

Vector number setting register WDT (VCRWDT) is a 16-bit read/write register that sets the WDT interval interrupt and BSC compare match interrupt vector numbers (0–127). VCRWDT is initialized to H'0000 by a reset. It is not initialized in standby mode.

Bit:	15	14	13	12	11	10	9	8
	—	WITV6	WITV5	WITV4	WITV3	WITV2	WITV1	WITV0
Initial value:	0	0	0	0	0	0	0	0
R/W:	R	R/W	R/W	R/W	R/W	R/W	R/W	R/W
Bit:	7	6	5	4	3	2	1	0
	—	BCMV6	BCMV5	BCMV4	BCMV3	BCMV2	BCMV1	BCMV0
Initial value:	0	0	0	0	0	0	0	0
R/W:	R	R/W	R/W	R/W	R/W	R/W	R/W	R/W

Bits 15 and 7—Reserved: These bits are always read as 0. The write value should always be 0.

Bits 14 to 8—Watchdog Timer (WDT) Interval Interrupt Vector Number 6 to 0 (WITV6–WITV0): These bits set the vector number for the interval interrupt (ITI) of the watchdog timer (WDT). There are seven bits, so the value can be set between 0 and 127.

Bits 6 to 0—Bus State Controller (BSC) Compare Match Interrupt Vector Number 6 to 0 (BCMV6–BCMV0): These bits set the vector number for the compare match interrupt (CMI) of the bus state controller (BSC). There are seven bits, so the value can be set between 0 and 127.

5.3.7 Vector Number Setting Register A (VCRA)

Vector number setting register A (VCRA) is a 16-bit read/write register that sets the E-DMAC interrupt vector numbers (0–127). VCRA is initialized to H'0000 by a reset. It is not initialized in standby mode.

Bit:	15	14	13	12	11	10	9	8
	—	EINV6	EINV5	EINV4	EINV3	EINV2	EINV1	EINV0
Initial value:	0	0	0	0	0	0	0	0
R/W:	R	R/W	R/W	R/W	R/W	R/W	R/W	R/W

Bit:	7	6	5	4	3	2	1	0
	—	—	—	—	—	—	—	—
Initial value:	0	0	0	0	0	0	0	0
R/W:	R	R	R	R	R	R	R	R

Bits 15 and 7 to 0—Reserved: These bits are always read as 0. The write value should always be 0.

Bits 14 to 8—Ethernet Controller Direct Memory Access Controller (E-DMAC) Interrupt Vector Number 6 to 0 (EINV6–EINV0): These bits set the vector number for ethernet controller direct memory access controller (E-DMAC) interrupt (EINT). There are seven bits, so the value can be set between 0 and 127.

5.3.8 Vector Number Setting Register B (VCRB)

Vector number setting register B (VCRB) is a 16-bit reserved register. Access to this register is prohibited. VCRB is initialized to H'0000 by a reset. It is not initialized in standby mode.

Bit:	15	14	13	12	11	10	9	8
	—	—	—	—	—	—	—	—
Initial value:	0	0	0	0	0	0	0	0
R/W:	R	R	R	R	R	R	R	R
Bit:	7	6	5	4	3	2	1	0
	—	—	—	—	—	—	—	—
Initial value:	0	0	0	0	0	0	0	0
R/W:	R	R	R	R	R	R	R	R

5.3.9 Vector Number Setting Register C (VCRC)

Vector number setting register C (VCRC) is a 16-bit read/write register that sets the 16-bit free-running timer (FRT) input-capture interrupt and output-compare interrupt vector numbers (0–127). VCRC is initialized to H'0000 by a reset. It is not initialized in standby mode.

Bit:	15	14	13	12	11	10	9	8
	—	FICV6	FICV5	FICV4	FICV3	FICV2	FICV1	FICV0
Initial value:	0	0	0	0	0	0	0	0
R/W:	R	R/W	R/W	R/W	R/W	R/W	R/W	R/W
Bit:	7	6	5	4	3	2	1	0
	—	FOCV6	FOCV5	FOCV4	FOCV3	FOCV2	FOCV1	FOCV0
Initial value:	0	0	0	0	0	0	0	0
R/W:	R	R/W	R/W	R/W	R/W	R/W	R/W	R/W

Bits 15 and 7—Reserved: These bits are always read as 0. The write value should always be 0.

Bits 14 to 8—16-Bit Free-Running Timer (FRT) Input-Capture Interrupt Vector Number 6 to 0 (FICV6–FICV0): These bits set the vector number for the 16-bit free-running timer (FRT) input-capture interrupt (ICI). There are seven bits, so the value can be set between 0 and 127.

Bits 6 to 0—16-Bit Free-Running Timer (FRT) Output-Compare Interrupt Vector Number 6 to 0 (FOCV6–FOCV0): These bits set the vector number for the 16-bit free-running timer (FRT) output-compare interrupt (OCI). There are seven bits, so the value can be set between 0 and 127.

5.3.10 Vector Number Setting Register D (VCRD)

Vector number setting register D (VCRD) is a 16-bit read/write register that sets the 16-bit free-running timer (FRT) overflow interrupt vector number (0–127). VCRD is initialized to H'0000 by a reset. It is not initialized in standby mode.

Bit:	15	14	13	12	11	10	9	8
	—	FOVV6	FOVV5	FOVV4	FOVV3	FOVV2	FOVV1	FOVV0
Initial value:	0	0	0	0	0	0	0	0
R/W:	R	R/W	R/W	R/W	R/W	R/W	R/W	R/W

Bit:	7	6	5	4	3	2	1	0
	—	—	—	—	—	—	—	—
Initial value:	0	0	0	0	0	0	0	0
R/W:	R	R	R	R	R	R	R	R

Bits 15 and 7 to 0—Reserved: These bits are always read as 0. The write value should always be 0.

Bits 14 to 8—16-Bit Free-Running Timer (FRT) Overflow Interrupt Vector Number 6 to 0 (FOVV6–FOVV0): These bits set the vector number for the 16-bit free-running timer (FRT) overflow interrupt (OVI). There are seven bits, so the value can be set between 0 and 127.

5.3.11 Vector Number Setting Register E (VCRE)

Vector number setting register E (VCRE) is a 16-bit read/write register that sets the 16-bit timer pulse unit 0 (TPU0) TGR0A and TGR0B input capture/compare match interrupt vector numbers (0–127).

VCRE is initialized to H'0000 by a reset. It is not initialized in standby mode.

Bit:	15	14	13	12	11	10	9	8
	—	TG0AV6	TG0AV5	TG0AV4	TG0AV3	TG0AV2	TG0AV1	TG0AV0
Initial value:	0	0	0	0	0	0	0	0
R/W:	R	R/W	R/W	R/W	R/W	R/W	R/W	R/W

Bit:	7	6	5	4	3	2	1	0
	—	TG0BV6	TG0BV5	TG0BV4	TG0BV3	TG0BV2	TG0BV1	TG0BV0
Initial value:	0	0	0	0	0	0	0	0
R/W:	R	R/W	R/W	R/W	R/W	R/W	R/W	R/W

Bits 15 and 7—Reserved: These bits are always read as 0. The write value should always be 0.

Bits 14 to 8—16-Bit Timer pulse unit 0 (TPU0) TGR0A Input Capture/Compare Match Interrupt Vector Number 6 to 0 (TG0AV6–TG0AV0): These bits set the vector number for the 16-bit timer pulse unit 0 (TPU0) TGR0A input capture/compare match interrupt. There are seven bits, so the value can be set between 0 and 127.

Bits 6 to 0—16-Bit Timer pulse unit 0 (TPU0) TGR0B Input Capture/Compare Match Interrupt Vector Number 6 to 0 (TG0BV6–TG0BV0): These bits set the vector number for the 16-bit timer pulse unit 0 (TPU0) TGR0B input capture/compare match interrupt. There are seven bits, so the value can be set between 0 and 127.

5.3.12 Vector Number Setting Register F (VCRF)

Vector number setting register F (VCRF) is a 16-bit read/write register that sets the 16-bit timer pulse unit 0 (TPU0) TGR0C and TGR0D input capture/compare match interrupt vector numbers (0–127).

VCRF is initialized to H'0000 by a reset. It is not initialized in standby mode.

Bit:	15	14	13	12	11	10	9	8
	—	TG0CV6	TG0CV5	TG0CV4	TG0CV3	TG0CV2	TG0CV1	TG0CV0
Initial value:	0	0	0	0	0	0	0	0
R/W:	R	R/W	R/W	R/W	R/W	R/W	R/W	R/W

Bit:	7	6	5	4	3	2	1	0
	—	TG0DV6	TG0DV5	TG0DV4	TG0DV3	TG0DV2	TG0DV1	TG0DV0
Initial value:	0	0	0	0	0	0	0	0
R/W:	R	R/W	R/W	R/W	R/W	R/W	R/W	R/W

Bits 15 and 7—Reserved: These bits are always read as 0. The write value should always be 0.

Bits 14 to 8—16-Bit Timer pulse unit 0 (TPU0) TGR0C Input Capture/Compare Match Interrupt Vector Number 6 to 0 (TG0CV6–TG0CV0): These bits set the vector number for the 16-bit timer pulse unit 0 (TPU0) TGR0C input capture/compare match interrupt. There are seven bits, so the value can be set between 0 and 127.

Bits 6 to 0—16-Bit Timer pulse unit 0 (TPU0) TGR0D Input Capture/Compare Match Interrupt Vector Number 6 to 0 (TG0DV6–TG0DV0): These bits set the vector number for the 16-bit timer pulse unit 0 (TPU0) TGR0D input capture/compare match interrupt. There are seven bits, so the value can be set between 0 and 127.

5.3.13 Vector Number Setting Register G (VCRG)

Vector number setting register G (VCRG) is a 16-bit read/write register that sets the 16-bit timer pulse unit 0 (TPU0) TCNT0 overflow interrupt vector number (0–127).

VCRG is initialized to H'0000 by a reset. It is not initialized in standby mode.

Bit:	15	14	13	12	11	10	9	8
	—	TC0VV6	TC0VV5	TC0VV4	TC0VV3	TC0VV2	TC0VV1	TC0VV0
Initial value:	0	0	0	0	0	0	0	0
R/W:	R	R/W	R/W	R/W	R/W	R/W	R/W	R/W

Bit:	7	6	5	4	3	2	1	0
	—	—	—	—	—	—	—	—
Initial value:	0	0	0	0	0	0	0	0
R/W:	R	R	R	R	R	R	R	R

Bits 15 and 7 to 0—Reserved: These bits are always read as 0. The write value should always be 0.

Bits 14 to 8—16-Bit Timer pulse unit 0 (TPU0) TCNT0 Overflow Interrupt Vector Number 6 to 0 (TC0VV6–TV0VV0): These bits set the vector number for the 16-bit timer pulse unit 0 (TPU0) TCNT0 overflow interrupt. There are seven bits, so the value can be set between 0 and 127.

5.3.14 Vector Number Setting Register H (VCRH)

Vector number setting register H (VCRH) is a 16-bit read/write register that sets the 16-bit timer pulse unit 1 (TPU1) TGR1A and TGR1B input capture/compare match interrupt vector numbers (0–127).

VCRH is initialized to H'0000 by a reset. It is not initialized in standby mode.

Bit:	15	14	13	12	11	10	9	8
	—	TG1AV6	TG1AV5	TG1AV4	TG1AV3	TG1AV2	TG1AV1	TG1AV0
Initial value:	0	0	0	0	0	0	0	0
R/W:	R	R/W	R/W	R/W	R/W	R/W	R/W	R/W

Bit:	7	6	5	4	3	2	1	0
	—	TG1BV6	TG1BV5	TG1BV4	TG1BV3	TG1BV2	TG1BV1	TG1BV0
Initial value:	0	0	0	0	0	0	0	0
R/W:	R	R/W	R/W	R/W	R/W	R/W	R/W	R/W

Bits 15 and 7—Reserved: These bits are always read as 0. The write value should always be 0.

Bits 14 to 8—16-Bit Timer pulse unit 1 (TPU1) TGR1A Input Capture/Compare Match Interrupt Vector Number 6 to 0 (TG1AV6–TG1AV0): These bits set the vector number for the 16-bit timer pulse unit 1 (TPU1) TGR1A input capture/compare match interrupt. There are seven bits, so the value can be set between 0 and 127.

Bits 6 to 0—16-Bit Timer pulse unit 1 (TPU1) TGR1B Input Capture/Compare Match Interrupt Vector Number 6 to 0 (TG1BV6–TG1BV0): These bits set the vector number for the 16-bit timer pulse unit 1 (TPU1) TGR1B input capture/compare match interrupt. There are seven bits, so the value can be set between 0 and 127.

5.3.15 Vector Number Setting Register I (VCRI)

Vector number setting register I (VCRI) is a 16-bit read/write register that sets the 16-bit timer pulse unit 1 (TPU1) TCNT1 overflow/underflow interrupt vector numbers (0–127).

VCRI is initialized to H'0000 by a reset. It is not initialized in standby mode.

Bit:	15	14	13	12	11	10	9	8
	—	TC1VV6	TC1VV5	TC1VV4	TC1VV3	TC1VV2	TC1VV1	TC1VV0
Initial value:	0	0	0	0	0	0	0	0
R/W:	R	R/W	R/W	R/W	R/W	R/W	R/W	R/W

Bit:	7	6	5	4	3	2	1	0
	—	TC1UV6	TC1UV5	TC1UV4	TC1UV3	TC1UV2	TC1UV1	TC1UV0
Initial value:	0	0	0	0	0	0	0	0
R/W:	R	R/W	R/W	R/W	R/W	R/W	R/W	R/W

Bits 15 and 7—Reserved: These bits are always read as 0. The write value should always be 0.

Bits 14 to 8—16-Bit Timer pulse unit 1 (TPU1) TCNT1 Overflow Interrupt Vector Number 6 to 0 (TC1VV6–TC1VV0): These bits set the vector number for the 16-bit timer pulse unit 1 (TPU1) TCNT1 overflow interrupt. There are seven bits, so the value can be set between 0 and 127.

Bits 6 to 0—16-Bit Timer pulse unit 1 (TPU1) TCNT1 Underflow Interrupt Vector Number 6 to 0 (TC1UV6–TC1UV0): These bits set the vector number for the 16-bit timer pulse unit 1 (TPU1) TCNT1 underflow interrupt. There are seven bits, so the value can be set between 0 and 127.

5.3.16 Vector Number Setting Register J (VCRJ)

Vector number setting register J (VCRJ) is a 16-bit read/write register that sets the 16-bit timer pulse unit 2 (TPU2) TGR2A and TGR2B input capture/compare match interrupt vector numbers (0–127).

VCRJ is initialized to H'0000 by a reset. It is not initialized in standby mode.

Bit:	15	14	13	12	11	10	9	8
	—	TG2AV6	TG2AV5	TG2AV4	TG2AV3	TG2AV2	TG2AV1	TG2AV0
Initial value:	0	0	0	0	0	0	0	0
R/W:	R	R/W	R/W	R/W	R/W	R/W	R/W	R/W

Bit:	7	6	5	4	3	2	1	0
	—	TG2BV6	TG2BV5	TG2BV4	TG2BV3	TG2BV2	TG2BV1	TG2BV0
Initial value:	0	0	0	0	0	0	0	0
R/W:	R	R/W	R/W	R/W	R/W	R/W	R/W	R/W

Bits 15 and 7—Reserved: These bits are always read as 0. The write value should always be 0.

Bits 14 to 8—16-Bit Timer pulse unit 2 (TPU2) TGR2A Input Capture/Compare Match Interrupt Vector Number 6 to 0 (TG2AV6–TG2AV0): These bits set the vector number for the 16-bit timer pulse unit 2 (TPU2) TGR2A input capture/compare match interrupt. There are seven bits, so the value can be set between 0 and 127.

Bits 6 to 0—16-Bit Timer pulse unit 2 (TPU2) TGR2B Input Capture/Compare Match Interrupt Vector Number 6 to 0 (TG2BV6–TG2BV0): These bits set the vector number for the 16-bit timer pulse unit 2 (TPU2) TGR2B input capture/compare match interrupt. There are seven bits, so the value can be set between 0 and 127.

5.3.17 Vector Number Setting Register K (VCRK)

Vector number setting register K (VCRK) is a 16-bit read/write register that sets the 16-bit timer pulse unit 2 (TPU2) TCNT2 overflow/underflow interrupt vector numbers (0–127).

VCRK is initialized to H'0000 by a reset. It is not initialized in standby mode.

Bit:	15	14	13	12	11	10	9	8
	—	TC2VV6	TC2VV5	TC2VV4	TC2VV3	TC2VV2	TC2VV1	TC2VV0
Initial value:	0	0	0	0	0	0	0	0
R/W:	R	R/W	R/W	R/W	R/W	R/W	R/W	R/W

Bit:	7	6	5	4	3	2	1	0
	—	TC2UV6	TC2UV5	TC2UV4	TC2UV3	TC2UV2	TC2UV1	TC2UV0
Initial value:	0	0	0	0	0	0	0	0
R/W:	R	R/W	R/W	R/W	R/W	R/W	R/W	R/W

Bits 15 and 7—Reserved: These bits are always read as 0. The write value should always be 0.

Bits 14 to 8—16-Bit Timer pulse unit 2 (TPU2) TCNT2 Overflow Interrupt Vector Number 6 to 0 (TC2VV6–TC2VV0): These bits set the vector number for the 16-bit timer pulse unit 2 (TPU2) TCNT2 overflow interrupt. There are seven bits, so the value can be set between 0 and 127.

Bits 6 to 0—16-Bit Timer pulse unit 2 (TPU2) TCNT2 Underflow Interrupt Vector Number 6 to 0 (TC2UV6–TC2UV0): These bits set the vector number for the 16-bit timer pulse unit 2 (TPU2) TCNT2 underflow interrupt. There are seven bits, so the value can be set between 0 and 127.

5.3.18 Vector Number Setting Register L (VCRL)

Vector number setting register L (VCRL) is a 16-bit read/write register that sets the serial communication interface with FIFO 1 (SCIF1) receive-error interrupt and receive-data-full/data-ready interrupt vector numbers (0–127).

VCRL is initialized to H'0000 by a reset. It is not initialized in standby mode.

Bit:	15	14	13	12	11	10	9	8
	—	SER1V6	SER1V5	SER1V4	SER1V3	SER1V2	SER1V1	SER1V0
Initial value:	0	0	0	0	0	0	0	0
R/W:	R	R/W	R/W	R/W	R/W	R/W	R/W	R/W

Bit:	7	6	5	4	3	2	1	0
	—	SRX1V6	SRX1V5	SRX1V4	SRX1V3	SRX1V2	SRX1V1	SRX1V0
Initial value:	0	0	0	0	0	0	0	0
R/W:	R	R/W	R/W	R/W	R/W	R/W	R/W	R/W

Bits 15 and 7—Reserved: These bits are always read as 0. The write value should always be 0.

Bits 14 to 8—Serial Communication Interface with FIFO 1 (SCIF1) Receive-Error Interrupt Vector Number 6 to 0 (SER1V6–SER1V0): These bits set the vector number for the serial communication interface with FIFO 1 (SCIF1) receive-error interrupt. There are seven bits, so the value can be set between 0 and 127.

Bits 6 to 0—Serial Communication Interface with FIFO 1 (SCIF1) Receive-Data-Full/Data-Ready Interrupt Vector Number 6 to 0 (SRX1V6–SRX1V0): These bits set the vector number for the serial communication interface with FIFO 1 (SCIF1) receive-data-full/data-ready interrupt. There are seven bits, so the value can be set between 0 and 127.

5.3.19 Vector Number Setting Register M (VCRM)

Vector number setting register M (VCRM) is a 16-bit read/write register that sets the serial communication interface with FIFO 1 (SCIF1) break interrupt and transmit-data-empty interrupt vector numbers (0–127).

VCRM is initialized to H'0000 by a reset. It is not initialized in standby mode.

Bit:	15	14	13	12	11	10	9	8
	—	SBR1V6	SBR1V5	SBR1V4	SBR1V3	SBR1V2	SBR1V1	SBR1V0
Initial value:	0	0	0	0	0	0	0	0
R/W:	R	R/W	R/W	R/W	R/W	R/W	R/W	R/W

Bit:	7	6	5	4	3	2	1	0
	—	STX1V6	STX1V5	STX1V4	STX1V3	STX1V2	STX1V1	STX1V0
Initial value:	0	0	0	0	0	0	0	0
R/W:	R	R/W	R/W	R/W	R/W	R/W	R/W	R/W

Bits 15 and 7—Reserved: These bits are always read as 0. The write value should always be 0.

Bits 14 to 8—Serial Communication Interface with FIFO 1 (SCIF1) Break Interrupt Vector Number 6 to 0 (SBR1V6–SBR1V0): These bits set the vector number for the serial communication interface with FIFO 1 (SCIF1) break interrupt. There are seven bits, so the value can be set between 0 and 127.

Bits 6 to 0—Serial Communication Interface with FIFO 1 (SCIF1) Transmit-Data-Empty Interrupt Vector Number 6 to 0 (STX1V6–STX1V0): These bits set the vector number for the serial communication interface with FIFO 1 (SCIF1) transmit-data-empty interrupt. There are seven bits, so the value can be set between 0 and 127.

5.3.20 Vector Number Setting Register N (VCRN)

Vector number setting register N (VCRN) is a 16-bit read/write register that sets the serial communication interface with FIFO 2 (SCIF2) receive-error interrupt and receive-data-full/data-ready interrupt vector numbers (0–127).

VCRN is initialized to H'0000 by a reset. It is not initialized in standby mode.

Bit:	15	14	13	12	11	10	9	8
	—	SER2V6	SER2V5	SER2V4	SER2V3	SER2V2	SER2V1	SER2V0
Initial value:	0	0	0	0	0	0	0	0
R/W:	R	R/W	R/W	R/W	R/W	R/W	R/W	R/W

Bit:	7	6	5	4	3	2	1	0
	—	SRX2V6	SRX2V5	SRX2V4	SRX2V3	SRX2V2	SRX2V1	SRX2V0
Initial value:	0	0	0	0	0	0	0	0
R/W:	R	R/W	R/W	R/W	R/W	R/W	R/W	R/W

Bits 15 and 7—Reserved: These bits are always read as 0. The write value should always be 0.

Bits 14 to 8—Serial Communication Interface with FIFO 2 (SCIF2) Receive-Error Interrupt Vector Number 6 to 0 (SER2V6–SER2V0): These bits set the vector number for the serial communication interface with FIFO 2 (SCIF2) receive-error interrupt. There are seven bits, so the value can be set between 0 and 127.

Bits 6 to 0—Serial Communication Interface with FIFO 2 (SCIF2) Receive-Data-Full/Data-Ready Interrupt Vector Number 6 to 0 (SRX2V6–SRX2V0): These bits set the vector number for the serial communication interface with FIFO 2 (SCIF2) receive-data-full/data-ready interrupt. There are seven bits, so the value can be set between 0 and 127.

5.3.21 Vector Number Setting Register O (VCRO)

Vector number setting register O (VCRO) is a 16-bit read/write register that sets the serial communication interface with FIFO 2 (SCIF2) break interrupt and transmit-data-empty interrupt vector numbers (0–127).

VCRO is initialized to H'0000 by a reset. It is not initialized in standby mode.

Bit:	15	14	13	12	11	10	9	8
	—	SBR2V6	SBR2V5	SBR2V4	SBR2V3	SBR2V2	SBR2V1	SBR2V0
Initial value:	0	0	0	0	0	0	0	0
R/W:	R	R/W	R/W	R/W	R/W	R/W	R/W	R/W

Bit:	7	6	5	4	3	2	1	0
	—	STX2V6	STX2V5	STX2V4	STX2V3	STX2V2	STX2V1	STX2V0
Initial value:	0	0	0	0	0	0	0	0
R/W:	R	R/W	R/W	R/W	R/W	R/W	R/W	R/W

Bits 15 and 7—Reserved: These bits are always read as 0. The write value should always be 0.

Bits 14 to 8—Serial Communication Interface with FIFO 2 (SCIF2) Break Interrupt Vector Number 6 to 0 (SBR2V6–SBR2V0): These bits set the vector number for the serial communication interface with FIFO 2 (SCIF2) break interrupt. There are seven bits, so the value can be set between 0 and 127.

Bits 6 to 0—Serial Communication Interface with FIFO 2 (SCIF2) Transmit-Data-Empty Interrupt Vector Number 6 to 0 (STX2V6–STX2V0): These bits set the vector number for the serial communication interface with FIFO 2 (SCIF2) transmit-data-empty interrupt. There are seven bits, so the value can be set between 0 and 127.

5.3.22 Vector Number Setting Register P (VCRP)

Vector number setting register P (VCRP) is a 16-bit read/write register that sets the serial I/O with FIFO (SIOF) receive overrun error interrupt and transmit underrun error interrupt vector numbers (0–127).

VCRP is initialized to H'0000 by a reset. It is not initialized in standby mode.

Bit:	15	14	13	12	11	10	9	8
	—	RER0V6	RER0V5	RER0V4	RER0V3	RER0V2	RER0V1	RER0V0
Initial value:	0	0	0	0	0	0	0	0
R/W:	R	R/W	R/W	R/W	R/W	R/W	R/W	R/W

Bit:	7	6	5	4	3	2	1	0
	—	TER0V6	TER0V5	TER0V4	TER0V3	TER0V2	TER0V1	TER0V0
Initial value:	0	0	0	0	0	0	0	0
R/W:	R	R/W	R/W	R/W	R/W	R/W	R/W	R/W

Bits 15 and 7—Reserved: These bits are always read as 0. The write value should always be 0.

Bits 14 to 8—Serial I/O with FIFO (SIOF) Receive Overrun Error Interrupt Vector Number 6 to 0 (RER0V6–RER0V0): These bits set the vector number for the serial I/O with FIFO (SIOF) receive overrun error interrupt. There are seven bits, so the value can be set between 0 and 127.

Bits 6 to 0—Serial I/O with FIFO (SIOF) Transmit Underrun Error Interrupt Vector Number 6 to 0 (TER0V6–TER0V0): These bits set the vector number for the serial I/O with FIFO (SIOF) transmit underrun error interrupt. There are seven bits, so the value can be set between 0 and 127.

5.3.23 Vector Number Setting Register Q (VCRQ)

Vector number setting register Q (VCRQ) is a 16-bit read/write register that sets the serial I/O with FIFO (SIOF) receive-data-full interrupt and transmit-data-empty interrupt vector numbers (0–127).

VCRQ is initialized to H'0000 by a reset. It is not initialized in standby mode.

Bit:	15	14	13	12	11	10	9	8
	—	RDF0V6	RDF0V5	RDF0V4	RDF0V3	RDF0V2	RDF0V1	RDF0V0
Initial value:	0	0	0	0	0	0	0	0
R/W:	R	R/W	R/W	R/W	R/W	R/W	R/W	R/W

Bit:	7	6	5	4	3	2	1	0
	—	TDE0V6	TDE0V5	TDE0V4	TDE0V3	TDE0V2	TDE0V1	TDE0V0
Initial value:	0	0	0	0	0	0	0	0
R/W:	R	R/W	R/W	R/W	R/W	R/W	R/W	R/W

Bits 15 and 7—Reserved: These bits are always read as 0. The write value should always be 0.

Bits 14 to 8—Serial I/O with FIFO (SIOF) Receive-Data-Full Interrupt Vector Number 6 to 0 (RDF0V6–RDF0V0): These bits set the vector number for the serial I/O with FIFO (SIOF) receive-data-full interrupt. There are seven bits, so the value can be set between 0 and 127.

Bits 6 to 0—Serial I/O with FIFO (SIOF) Transmit-Data-Empty Interrupt Vector Number 6 to 0 (TDE0V6–TDE0V0): These bits set the vector number for the serial I/O with FIFO (SIOF) transmit-data-empty interrupt. There are seven bits, so the value can be set between 0 and 127.

5.3.24 Vector Number Setting Register R (VCRR)

Vector number setting register R (VCRR) is a 16-bit read/write register that sets the serial I/O 1 (SIO1) receive overrun error interrupt and transmit underrun error interrupt vector numbers (0–127).

VCRR is initialized to H'0000 by a reset. It is not initialized in standby mode.

Bit:	15	14	13	12	11	10	9	8
	—	RER1V6	RER1V5	RER1V4	RER1V3	RER1V2	RER1V1	RER1V0
Initial value:	0	0	0	0	0	0	0	0
R/W:	R	R/W	R/W	R/W	R/W	R/W	R/W	R/W

Bit:	7	6	5	4	3	2	1	0
	—	TER1V6	TER1V5	TER1V4	TER1V3	TER1V2	TER1V1	TER1V0
Initial value:	0	0	0	0	0	0	0	0
R/W:	R	R/W	R/W	R/W	R/W	R/W	R/W	R/W

Bits 15 and 7—Reserved: These bits are always read as 0. The write value should always be 0.

Bits 14 to 8—Serial I/O 1 (SIO1) Receive Overrun Error Interrupt Vector Number 6 to 0 (RER1V6–RER1V0): These bits set the vector number for the serial I/O 1 (SIO1) receive overrun error interrupt. There are seven bits, so the value can be set between 0 and 127.

Bits 6 to 0—Serial I/O 1 (SIO1) Transmit Underrun Error Interrupt Vector Number 6 to 0 (TER1V6–TER1V0): These bits set the vector number for the serial I/O 1 (SIO1) transmit underrun error interrupt. There are seven bits, so the value can be set between 0 and 127.

5.3.25 Vector Number Setting Register S (VCRS)

Vector number setting register S (VCRS) is a 16-bit read/write register that sets the serial I/O 1 (SIO1) receive-data-full interrupt and transmit-data-empty interrupt vector numbers (0–127).

VCRS is initialized to H'0000 by a reset. It is not initialized in standby mode.

Bit:	15	14	13	12	11	10	9	8
	—	RDF1V6	RDF1V5	RDF1V4	RDF1V3	RDF1V2	RDF1V1	RDF1V0
Initial value:	0	0	0	0	0	0	0	0
R/W:	R	R/W	R/W	R/W	R/W	R/W	R/W	R/W

Bit:	7	6	5	4	3	2	1	0
	—	TDE1V6	TDE1V5	TDE1V4	TDE1V3	TDE1V2	TDE1V1	TDE1V0
Initial value:	0	0	0	0	0	0	0	0
R/W:	R	R/W	R/W	R/W	R/W	R/W	R/W	R/W

Bits 15 and 7—Reserved: These bits are always read as 0. The write value should always be 0.

Bits 14 to 8—Serial I/O 1 (SIO1) Receive-Data-Full Interrupt Vector Number 6 to 0 (RDF1V6–RDF1V0): These bits set the vector number for the serial I/O 1 (SIO1) receive-data-full interrupt. There are seven bits, so the value can be set between 0 and 127.

Bits 6 to 0—Serial I/O 1 (SIO1) Transmit-Data-Empty Interrupt Vector Number 6 to 0 (TDE1V6–TDE1V0): These bits set the vector number for the serial I/O 1 (SIO1) transmit-data-empty interrupt. There are seven bits, so the value can be set between 0 and 127.

5.3.26 Vector Number Setting Register T (VCRT)

Vector number setting register T (VCRT) is a 16-bit read/write register that sets the serial I/O 2 (SIO2) receive overrun error interrupt and transmit underrun error interrupt vector numbers (0–127).

VCRT is initialized to H'0000 by a reset. It is not initialized in standby mode.

Bit:	15	14	13	12	11	10	9	8
	—	RER2V6	RER2V5	RER2V4	RER2V3	RER2V2	RER2V1	RER2V0
Initial value:	0	0	0	0	0	0	0	0
R/W:	R	R/W	R/W	R/W	R/W	R/W	R/W	R/W

Bit:	7	6	5	4	3	2	1	0
	—	TER2V6	TER2V5	TER2V4	TER2V3	TER2V2	TER2V1	TER2V0
Initial value:	0	0	0	0	0	0	0	0
R/W:	R	R/W	R/W	R/W	R/W	R/W	R/W	R/W

Bits 15 and 7—Reserved: These bits are always read as 0. The write value should always be 0.

Bits 14 to 8—Serial I/O 2 (SIO2) Receive Overrun Error Interrupt Vector Number 6 to 0 (RER2V6–RER2V0): These bits set the vector number for the serial I/O 2 (SIO2) receive overrun error interrupt. There are seven bits, so the value can be set between 0 and 127.

Bits 6 to 0—Serial I/O 2 (SIO2) Transmit Underrun Error Interrupt Vector Number 6 to 0 (TER2V6–TER2V0): These bits set the vector number for the serial I/O 2 (SIO2) transmit underrun error interrupt. There are seven bits, so the value can be set between 0 and 127.

5.3.27 Vector Number Setting Register U (VCRU)

Vector number setting register U (VCRU) is a 16-bit read/write register that sets the serial I/O 2 (SIO2) receive-data-full interrupt and transmit-data-empty interrupt vector numbers (0–127).

VCRU is initialized to H'0000 by a reset. It is not initialized in standby mode.

Bit:	15	14	13	12	11	10	9	8
	—	RDF2V6	RDF2V5	RDF2V4	RDF2V3	RDF2V2	RDF2V1	RDF2V0
Initial value:	0	0	0	0	0	0	0	0
R/W:	R	R/W	R/W	R/W	R/W	R/W	R/W	R/W

Bit:	7	6	5	4	3	2	1	0
	—	TDE2V6	TDE2V5	TDE2V4	TDE2V3	TDE2V2	TDE2V1	TDE2V0
Initial value:	0	0	0	0	0	0	0	0
R/W:	R	R/W	R/W	R/W	R/W	R/W	R/W	R/W

Bits 15 and 7—Reserved. These bits are always read as 0. The write value should always be 0.

Bits 14 to 8—Serial I/O 2 (SIO2) Receive-Data-Full Interrupt Vector Number 6 to 0 (RDF2V6–RDF2V0): These bits set the vector number for the serial I/O 2 (SIO2) receive-data-full interrupt. There are seven bits, so the value can be set between 0 and 127.

Bits 6 to 0—Serial I/O 2 (SIO2) Transmit-Data-Empty Interrupt Vector Number 6 to 0 (TDE2V6–TDE2V0): These bits set the vector number for the serial I/O 2 (SIO2) transmit-data-empty interrupt. There are seven bits, so the value can be set between 0 and 127.

Tables 5.6 and 5.7 show the relationship between on-chip peripheral module interrupts and interrupt vector number setting registers.

Table 5.6 Interrupt Request Sources and Vector Number Setting Registers (1)

Register	Bits	
	14–8	6–0
Vector number setting register WDT	Interval interrupt (WDT)	Compare-match interrupt (BSC)
Vector number setting register A	E-DMAC interrupt (E-DMAC)	Reserved
Vector number setting register B	Reserved	Reserved
Vector number setting register C	Input-capture interrupt (FRT)	Output-compare interrupt (FRT)
Vector number setting register D	Overflow interrupt (FRT)	Reserved
Vector number setting register E	Input capture/compare match interrupt (TPU0/TGR0A)	Input capture/compare match interrupt (TPU0/TGR0B)
Vector number setting register F	Input capture/compare match interrupt (TPU0/TGR0C)	Input capture/compare match interrupt (TPU0/TGR0D)
Vector number setting register G	Overflow interrupt (TPU0/TCNT0)	Reserved
Vector number setting register H	Input capture/compare match interrupt (TPU1/TGR1A)	Input capture/compare match interrupt (TPU1/TGR1B)
Vector number setting register I	Overflow interrupt (TPU1/TCNT1)	Underflow interrupt (TPU1/TCNT1)
Vector number setting register J	Input capture/compare match interrupt (TPU2/TGR2A)	Input capture/compare match interrupt (TPU2/TGR2B)
Vector number setting register K	Overflow interrupt (TPU2/TCNT2)	Underflow interrupt (TPU2/TCNT2)
Vector number setting register L	Receive-error interrupt (SCIF1)	Receive-data-full/data-ready interrupt (SCIF1)
Vector number setting register M	Break interrupt (SCIF1)	Transmit-data-empty interrupt (SCIF1)
Vector number setting register N	Receive-error interrupt (SCIF2)	Receive-data-full/data-ready interrupt (SCIF2)
Vector number setting register O	Break interrupt (SCIF2)	Transmit-data-empty interrupt (SCIF2)
Vector number setting register P	Receive overrun error interrupt (SIOF)	Transmit underrun error interrupt (SIOF)
Vector number setting register Q	Receive-data-full interrupt (SIOF)	Transmit-data-empty interrupt (SIOF)

Table 5.6 Interrupt Request Sources and Vector Number Setting Registers (1) (cont)

Register	Bits	
	14–8	6–0
Vector number setting register R	Receive overrun error interrupt (SIO1)	Transmit underrun error interrupt (SIO1)
Vector number setting register S	Receive-data-full interrupt (SIO1)	Transmit-data-empty interrupt (SIO1)
Vector number setting register T	Receive overrun error interrupt (SIO2)	Transmit underrun error interrupt (SIO2)
Vector number setting register U	Receive-data-full interrupt (SIO2)	Transmit-data-empty interrupt (SIO2)

As table 5.6 shows, two on-chip peripheral module interrupts are assigned to each register. Set the vector numbers by setting the corresponding 7-bit groups (bits 14 to 8 and bits 6 to 0) with values in the range of H'00 (0000000) to H'7F (1111111). H'00 is vector number 0 (the lowest); H'7F is vector number 127 (the highest). The vector table address is calculated by the following equation.

$$\text{Vector table address} = \text{VBR} + (\text{vector number} \times 4)$$

A reset initializes a vector number setting register to H'0000. They are not initialized in standby mode.

Table 5.7 Interrupt Request Sources and Vector Number Setting Registers (2)

Register	Setting Function
Vector number setting register DMA0 (VCRDMA0)	Channel 0 transfer end interrupt for DMAC
Vector number setting register DMA1 (VCRDMA1)	Channel 1 transfer end interrupt for DMAC

As shown in table 5.7 the vector numbers for direct memory access controller transfer-end interrupts are set in VCRDMA0 and VCRDMA1. See sections 11, Direct Memory Access Controller, for more details.

5.3.28 Interrupt Control Register (ICR)

ICR is a 16-bit register that sets the input signal detection mode of external interrupt input pin NMI and indicates the input signal level at the NMI pin. It can also specify IRQ or IRL mode by means of the External Interrupt Vector Mode Select bit. The IRQ/IRL interrupt vector number can be selected for setting in accordance with either auto vector mode or external vector mode by means of the Interrupt Vector Mode Select bit. ICR is initialized to H'8000 or H'0000 by a reset. It is not initialized in standby mode.

Bit:	15	14	13	12	11	10	9	8
	NMIL	—	—	—	—	—	—	NMIE
Initial value:	0/1*	0	0	0	0	0	0	0
R/W:	R	R	R	R	R	R	R	R/W
Bit:	7	6	5	4	3	2	1	0
	—	—	—	—	—	—	EXIMD	VECMD
Initial value:	0	0	0	0	0	0	0	0
R/W:	R	R	R	R	R	R	R/W	R/W

Note: * When NMI input is high: 1; when NMI input is low: 0

Bit 15—NMI Input Level (NMIL): Sets the level of the signal input at the NMI pin. This bit can be read to determine the NMI pin level. This bit cannot be modified.

Bit 15: NMIL	Description
0	NMI input level is low
1	NMI input level is high

Bits 14 to 9—Reserved: These bits are always read as 0. The write value should always be 0.

Bit 8—NMI Edge Select (NMIE): Selects whether the falling or rising edge of the interrupt request signal to the NMI pin is detected.

Bit 8: NMIE	Description
0	Interrupt request is detected on falling edge of NMI input (Initial value)
1	Interrupt request is detected on rising edge of NMI input

Bits 7 to 2—Reserved: These bits are always read as 0. The write value should always be 0.

Bit 1—External Interrupt Vector Mode Select (EXIMD): This bit selects IRQ mode or IRL mode. In IRQ mode, each of signals $\overline{IRL3}$ to $\overline{IRL0}$ functions as a separate interrupt source. In IRL mode, these signals can specify interrupt priority levels 1 to 15.

Bit 1: EXIMD	Description
0	IRL mode (Initial value)
1	IRQ mode

Bit 0—Interrupt Vector Mode Select (VECMD): This bit selects auto-vector mode or external vector mode for IRL/IRQ interrupt vector number setting. In auto-vector mode, an internally determined vector number is set. The IRL15 and IRL14 interrupt vector numbers are set to 71 and the IRL1 vector number is set to 64. In external vector mode, a value between 0 and 127 can be input as the vector number from the external vector number input pins (D7–D0).

Bit 0: VECMD	Description
0	Auto vector mode, vector number automatically set internally (Initial value)
1	External vector mode, vector number set by external input

5.3.29 IRQ Control/Status Register (IRQCSR)

The IRQ control/status register (IRQCSR) is a 16-bit register that sets the $\overline{IRL0}$ – $\overline{IRL3}$ input signal detection mode, indicates the input signal levels at pins $\overline{IRL0}$ – $\overline{IRL3}$, and also indicates the IRQ interrupt status. IRQCSR is initialized by a reset. It is not initialized in standby mode.

Bit:	15	14	13	12	11	10	9	8
	IRQ31S	IRQ30S	IRQ21S	IRQ20S	IRQ11S	IRQ10S	IRQ01S	IRQ00S
Initial value:	0	0	0	0	0	0	0	0
R/W:	R/W	R/W	R/W	R/W	R/W	R/W	R/W	R/W
Bit:	7	6	5	4	3	2	1	0
	IRL3PS	IRL2PS	IRL1PS	IRL0PS	IRQ3F	IRQ2F	IRQ1F	IRQ0F
Initial value:	0/1	0/1	0/1	0/1	0	0	0	0
R/W:	R	R	R	R	R/(W)*	R/(W)*	R/(W)*	R/(W)*

Note: * Only 0 can be written, to clear the flag (in case of edge detection).

Bits 15 to 8—IRQ Sense Select Bits (IRQ31S–IRQ00S): These bits set the IRQ detection mode for IRL3–IRL0.

Bit 15–8: IRQn1S	Bit 15–8: IRQn0S	Description
0	0	Low-level detection (Initial value)
	1	Rising-edge detection
1	0	Falling-edge detection
	1	Both-edge detection

Note: n = 0 to 3

Bits 7 to 4—IRL Pin Status Bits (IRL3PS–IRL0PS): These bits indicate the $\overline{\text{IRL3}}$ – $\overline{\text{IRL0}}$ pin status. The $\overline{\text{IRL3}}$ – $\overline{\text{IRL0}}$ pin levels can be ascertained by reading these bits. These bits cannot be modified.

Bit 7–4: IRLnPS	Description
0	Low level is being input to pin $\overline{\text{IRLn}}$
1	High level is being input to pin $\overline{\text{IRLn}}$

Note: n = 0 to 3

Bits 3 to 0—IRQ3 to IRQ0 Flags (IRQ3F–IRQ0F): These bits indicate the IRQ3–IRQ0 interrupt request status.

Bit 3–0: IRQ3F–IRQ0F	Detection Setting	Description
0	Level detection	There is no IRQn interrupt request (Initial value) [Clearing condition] When $\overline{\text{IRLn}}$ input is high
	Edge detection	An IRQn interrupt request has not been detected (Initial value) [Clearing conditions] <ul style="list-style-type: none"> When 0 is written to IRQnF after reading IRQnF = 1 When an IRQn interrupt is accepted
1	Level detection	There is an IRQn interrupt request [Setting condition] When $\overline{\text{IRLn}}$ input is low
	Edge detection	An IRQn interrupt request has been detected [Setting condition] When an $\overline{\text{IRLn}}$ input edge is detected

Note: n = 0 to 3

5.4 Interrupt Operation

5.4.1 Interrupt Sequence

The sequence of operations in interrupt generation is described below and illustrated in figure 5.8.

1. The interrupt request sources send interrupt request signals to the interrupt controller.
2. The interrupt controller selects the highest-priority interrupt among the interrupt requests sent, according to the priority levels set in interrupt priority level setting registers A to E (IPRA–IPRE). Lower-priority interrupts are held pending. If two or more of these interrupts have the same priority level or if multiple interrupts occur within a single module, the interrupt with the highest default priority or the highest priority within its IPR setting unit (as indicated in table 5.4) is selected.
3. The interrupt controller compares the priority level of the selected interrupt request with the interrupt mask bits (I3–I0) in the CPU’s status register (SR). If the request priority level is equal to or less than the level set in I3–I0, the request is held pending. If the request priority level is higher than the level in bits I3–I0, the interrupt controller accepts the interrupt and sends an interrupt request signal to the CPU.
4. The CPU detects the interrupt request sent from the interrupt controller when it decodes the next instruction to be executed. Instead of executing the decoded instruction, the CPU starts interrupt exception handling.
5. Status register (SR) and program counter (PC) are saved onto the stack.
6. The priority level of the accepted interrupt is copied to the interrupt mask level bits (I3 to I0) in the status register (SR).
7. When external vector mode is specified for the IRL/IRQ interrupt, the vector number is read from the external vector number input pins (D7–D0).
8. The CPU reads the start address of the exception service routine from the exception vector table entry for the accepted interrupt, jumps to that address, and starts executing the program there. This jump is not a delayed branch.

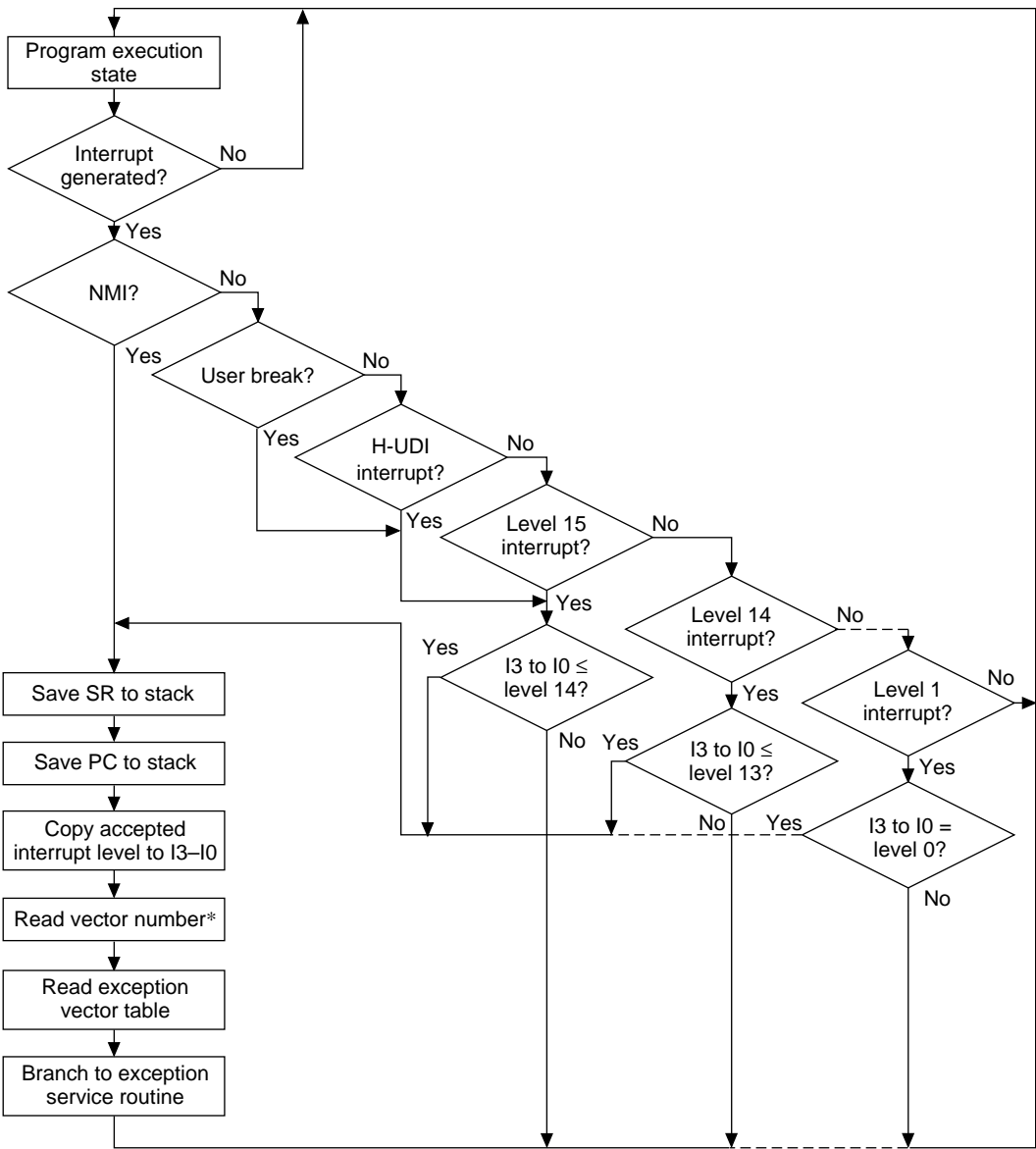

I3-I0: Status register interrupt mask bits.

Note: * The vector number is only read from an external source when an external vector number is specified for the IRL/IRQ interrupt vector number.

Figure 5.8 Interrupt Sequence Flowchart

5.4.2 Stack State after Interrupt Exception Handling

The state of the stack after interrupt exception handling is completed is shown in figure 5.9.

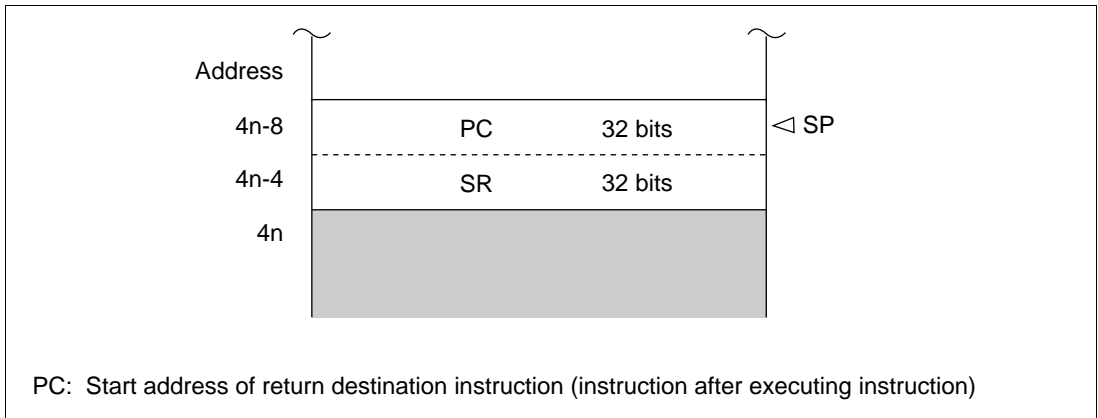

Figure 5.9 Stack State after Interrupt Exception Handling

5.5 Interrupt Response Time

Table 5.8 shows the interrupt response time, which is the time from the occurrence of an interrupt request until interrupt exception handling starts and fetching of the first instruction of the interrupt service routine begins.

Table 5.8 Interrupt Response Time

Item	Number of States				Notes
	NMI	IRL/IRQ	Peripheral Module		
			A	B	
Compare identified interrupt priority with SR mask level	$2.0 \times \text{Icyc}$	$0.5 \times \text{Icyc} + 1.0 \times \text{Ecyc} + 1.5 \times \text{Pcyc}$	$0.5 \times \text{Icyc} + 1.0 \times \text{Pcyc}$	$1.0 \times \text{Pcyc}$	
Wait for completion of sequence currently being executed by CPU	$X (\geq 0)$	$X (\geq 0)$	$X (\geq 0)$	$X (\geq 0)$	The longest sequence is for interrupt or address-error exception handling ($X = 4.0 \times \text{Icyc} + m1 + m2 + m3 + m4$). If an interrupt-making instruction follows, however, the time may be even longer during repeat instruction execution
Time from interrupt exception handling (SR and PC saves and vector address fetch) until fetch of first instruction of exception service routine starts	$5.0 \times \text{Icyc} + m1 + m2 + m3$	$5.0 \times \text{Icyc} + m1 + m2 + m3$	$5.0 \times \text{Icyc} + m1 + m2 + m3$	$5.0 \times \text{Icyc} + m1 + m2 + m3$	
Response time	Total: $X + 7.0 \times \text{Icyc} + m1 + m2 + m3$	$X + 5.5 \times \text{Icyc} + 1.0 \times \text{Ecyc} + 1.5 \times \text{Pcyc} + m1 + m2 + m3$	$X + 5.5 \times \text{Icyc} + 1.0 \times \text{Pcyc} + m1 + m2 + m3$	$X + 5.0 \times \text{Icyc} + 1.0 \times \text{Pcyc} + m1 + m2 + m3$	
	Minimum: 10	11	9.5	9	$\text{I}\phi:\text{E}\phi:\text{P}\phi = 1:1:1$
	Maximum: $11 + 2 (m1 + m2 + m3) + m4$	$19.5 + 2 (m1 + m2 + m3) + m4$	$13.5 + 2 (m1 + m2 + m3) + m4$	$13.0 + 2 (m1 + m2 + m3) + m4$	$\text{I}\phi:\text{E}\phi:\text{P}\phi = 1:1/4:1/4$

Notes: m1–m4 are the number of states needed for the following memory accesses

m1: SR save (longword write)

m2: PC save (longword write)

m3: Vector address read (longword read)

m4: Fetch of first instruction of interrupt service routine

Icyc: $\text{I}\phi$ cycle time

Ecyc: $\text{E}\phi$ cycle time

Pcyc: $\text{P}\phi$ cycle time

Peripheral modules A: DMAC, REF (BSC)

Peripheral modules B: WDT, FRT, TPU, SCIF, SIOF, SIO, E-DMAC

5.6 Sampling of Pins $\overline{\text{IRL3}}$ – $\overline{\text{IRL0}}$

Signals on interrupt pins $\overline{\text{IRL3}}$ to $\overline{\text{IRL0}}$ pass through the noise canceler before being sent by the interrupt controller to the CPU as interrupt requests, as shown in figure 5.10. The noise canceler cancels noise that changes in short cycles. The CPU samples the interrupt requests between executing instructions. During this period, the noise canceler output changes according to the noise-eliminated pin level, so the pin level must be held until the CPU samples it. This means that interrupt sources generally must not be cleared inside interrupt routines.

When an external vector is fetched, the interrupt source can also be cleared when the external vector fetch cycle is detected.

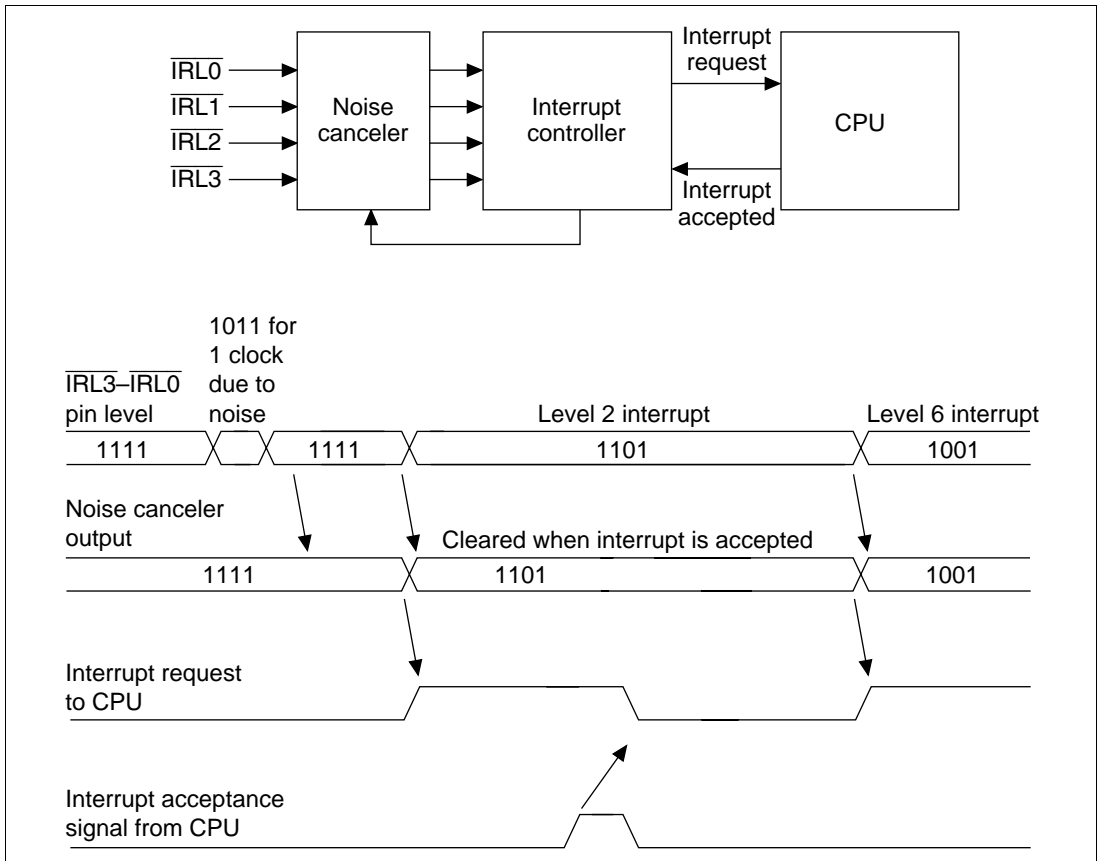

Figure 5.10 $\overline{\text{IRL3}}\text{--}\overline{\text{IRL0}}$ Pin Sampling

5.7 Usage Notes

1. Note on module standby execution

Do not execute module standby for modules that have the module standby function when the possibility remains that an interrupt request may be output.

2. Notes on interrupt source clearing

A. When clearing external interrupt source

If interrupt source clearing is performed by writing to an IO address (external), the next instruction will be executed before completion of the write operation because of the write buffer. To ensure that the write operation is completed before the next instruction is executed, synchronization is achieved when a read is performed from the same address following the write.

a. When returning from interrupt handling by means of RTE instruction

When the RTE instruction is used to return from interrupt handling, as shown in figure 5.11, consider the cycles to be inserted between the read instruction for synchronization and the RTE instruction, according to the set clock ratio ($I\phi : E\phi : P\phi$) and external bus cycle.

IRL3—IRL0 should be negated at least $0.5 I_{cyc} + 1.0 E_{cyc} + 1.5 P_{cyc}$ before next interrupt acceptance becomes possible.

For example, if clock ratio $I\phi : E\phi : P\phi$ is 4 : 2 : 2, at least 5.5 I_{cyc} should be inserted.

b. When changing level during interrupt handling

When the SR value is changed by means of an LDC instruction and multiple implementation of other interrupts is enabled, also, consider the cycles to be inserted between the synchronization instruction and the LDC instruction as shown in figure 5.12, according to the set clock ratio ($I\phi : E\phi : P\phi$) and external bus cycle.

IRL3—IRL0 should be negated at least $0.5 I_{cyc} + 1.0 E_{cyc} + 1.5 P_{cyc}$ before next interrupt acceptance becomes possible.

For example, if clock ratio $I\phi : E\phi : P\phi$ is 4 : 2 : 2, at least 5.5 I_{cyc} should be inserted.

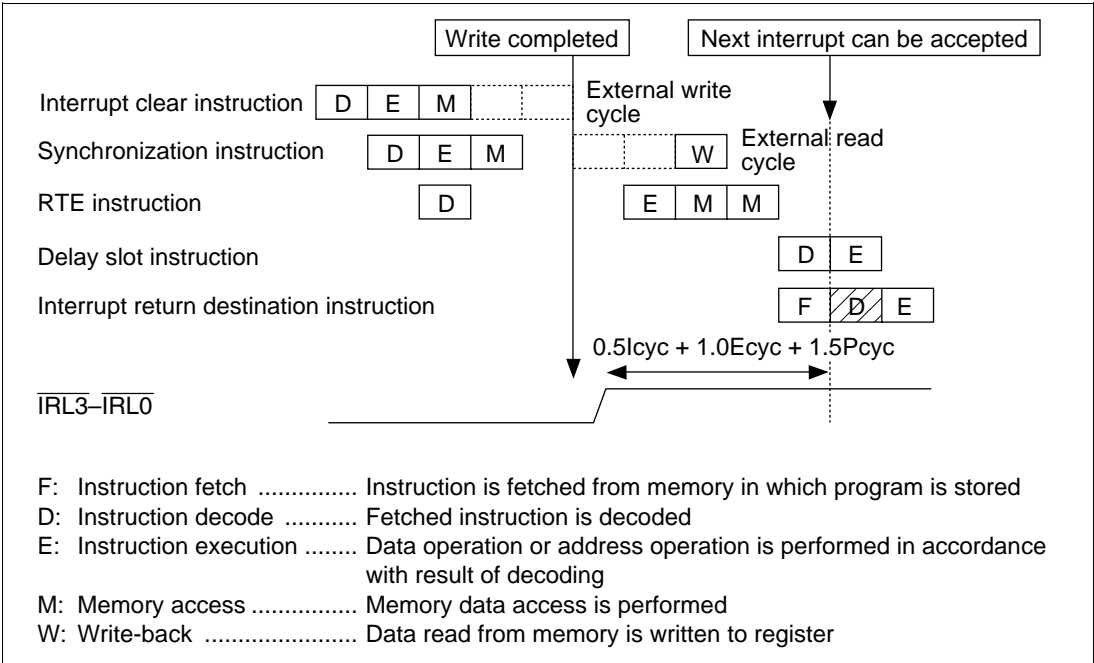

Figure 5.11 Pipeline Operation when Returning by Means of RTE Instruction

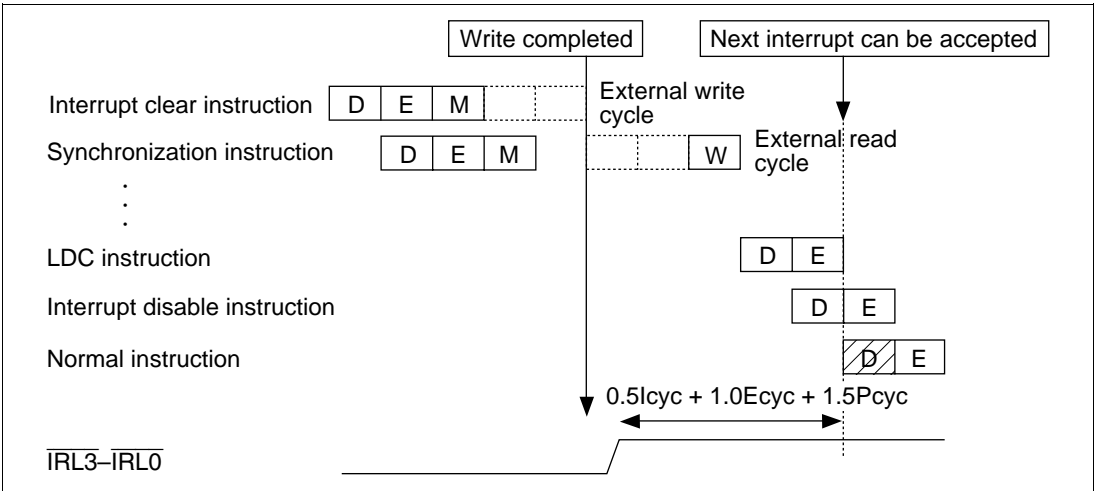

Figure 5.12 Pipeline Operation when Interrupts are Enabled by Means of SR Modification

When an interrupt source is cleared by the program, pipeline operation must be considered to ensure that the same interrupt is not implemented again.

B. When clearing on-chip interrupt source

When an interrupt source is from an on-chip peripheral module, also, pipeline operation must be considered to ensure that the same interrupt is not implemented again. An interval of $0.5 I_{cyc} + 1.0 P_{cyc}$ is required until an on-chip peripheral module interrupt is identified by the CPU. Similarly, an interval of $0.5 I_{cyc} + 1.0 P_{cyc}$ is also necessary to report the fact that an interrupt request is no longer present.

a. When returning from interrupt handling by means of RTE instruction

When the RTE instruction is used to return from interrupt handling, as shown in figure 5.13, consider the cycles to be inserted between the read instruction for synchronization and the RTE instruction, according to the set clock ratio ($I\phi : E\phi : P\phi$).

The on-chip peripheral interrupt signal should be negated at least $0.5 I_{cyc} + 1.0 P_{cyc}$ before next interrupt acceptance becomes possible.

For example, if clock ratio $I\phi : E\phi : P\phi$ is 4 : 2 : 2, at least 2.5 I_{cyc} should be inserted.

b. When changing level during interrupt handling

When the SR value is changed by means of an LDC instruction and multiple implementation of other interrupts is enabled, consider the cycles to be inserted between the synchronization instruction and the LDC instruction as shown in figure 5.14, according to the set clock ratio ($I\phi : E\phi : P\phi$).

The on-chip peripheral interrupt signal should be negated at least $0.5 I_{cyc} + 1.0 P_{cyc}$ before next interrupt acceptance becomes possible.

For example, if clock ratio $I\phi : E\phi : P\phi$ is 4 : 2 : 2, at least 2.5 I_{cyc} should be inserted.

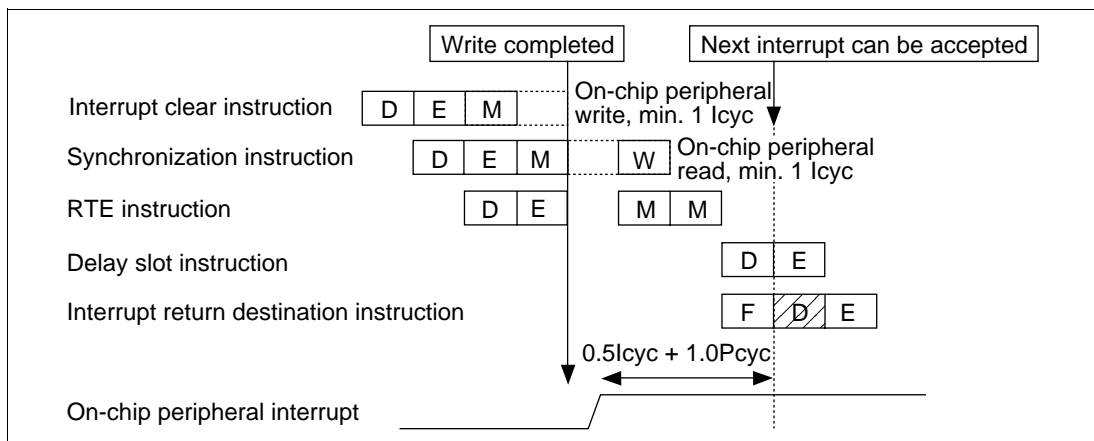

Figure 5.13 Pipeline Operation when Returning by Means of RTE Instruction

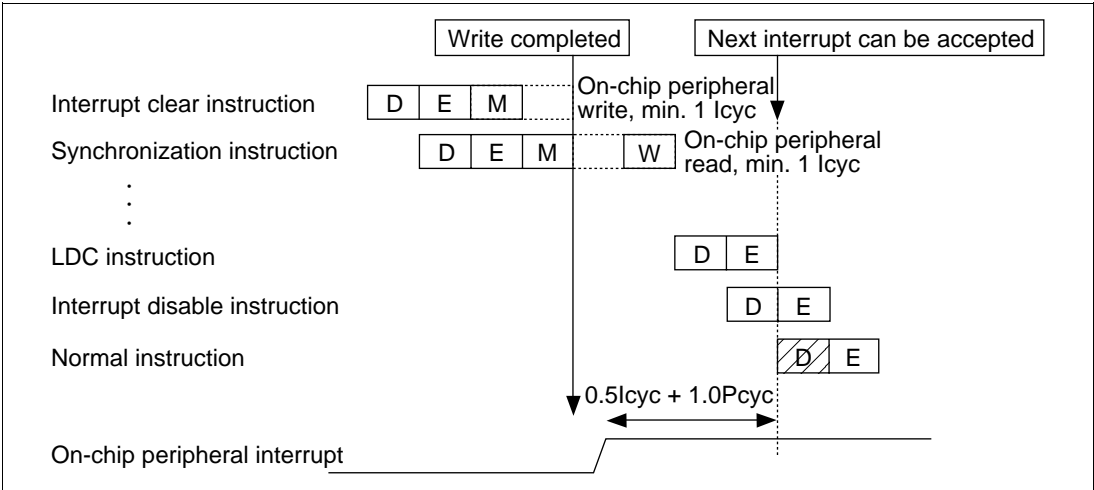

Figure 5.14 Pipeline Operation when Interrupts are Enabled by Means of SR Modification

In the above figure, the stage in which the instruction fetch occurs cannot be specified because of the mix of DSP instructions in this chip, so instruction fetch F is omitted in most cases during pipeline operation.

Section 6 User Break Controller (UBC)

6.1 Overview

The user break controller (UBC) provides functions that simplify program debugging. When break conditions are set in the UBC, a user break interrupt is generated according to the conditions of the bus cycle generated by the CPU or on-chip DMAC (DMAC or E-DMAC).

This function makes it easy to design a sophisticated self-monitoring debugger, enabling programs to be debugged with the chip alone, without using an in-circuit emulator.

6.1.1 Features

The UBC has the following features:

- The following can be set as break conditions:
 - Number of break channels: Four (channels A, B, C, and D)
User break interrupts can be generated on independent or sequential conditions for channels A, B, C, and D.
 - Sequential break settings
 - Channel A → channel B → channel C → channel D
 - Channel B → channel C → channel D
 - Channel C → channel D
- 1. Address: 32-bit masking capability, individual address setting possible (cache bus (CPU), internal bus (DMAC, E-DMAC), X/Y bus)
- 2. Data (channels C and D only,): 32-bit masking capability, individual address setting possible (cache bus (CPU), internal bus (DMAC, E-DMAC), X/Y bus)
- 3. Bus master: CPU cycle/on-chip DMAC (DMAC, E-DMAC) cycle
- 4. Bus cycle: Instruction fetch/data access
- 5. Read/write
- 6. Operand cycle: Byte/word/longword
- User break interrupt generation on occurrence of break condition
A user-written user break interrupt exception routine can be executed.
- Processing can be stopped before or after instruction execution in an instruction fetch cycle.
- Break with specification of number of executions (channels C and D only)
Settable number of executions: maximum $2^{12} - 1$ (4095)
- PC trace function
The branch source/branch destination can be traced when a branch instruction is fetched (maximum 8 addresses (4 pairs)).

6.1.2 Block Diagram

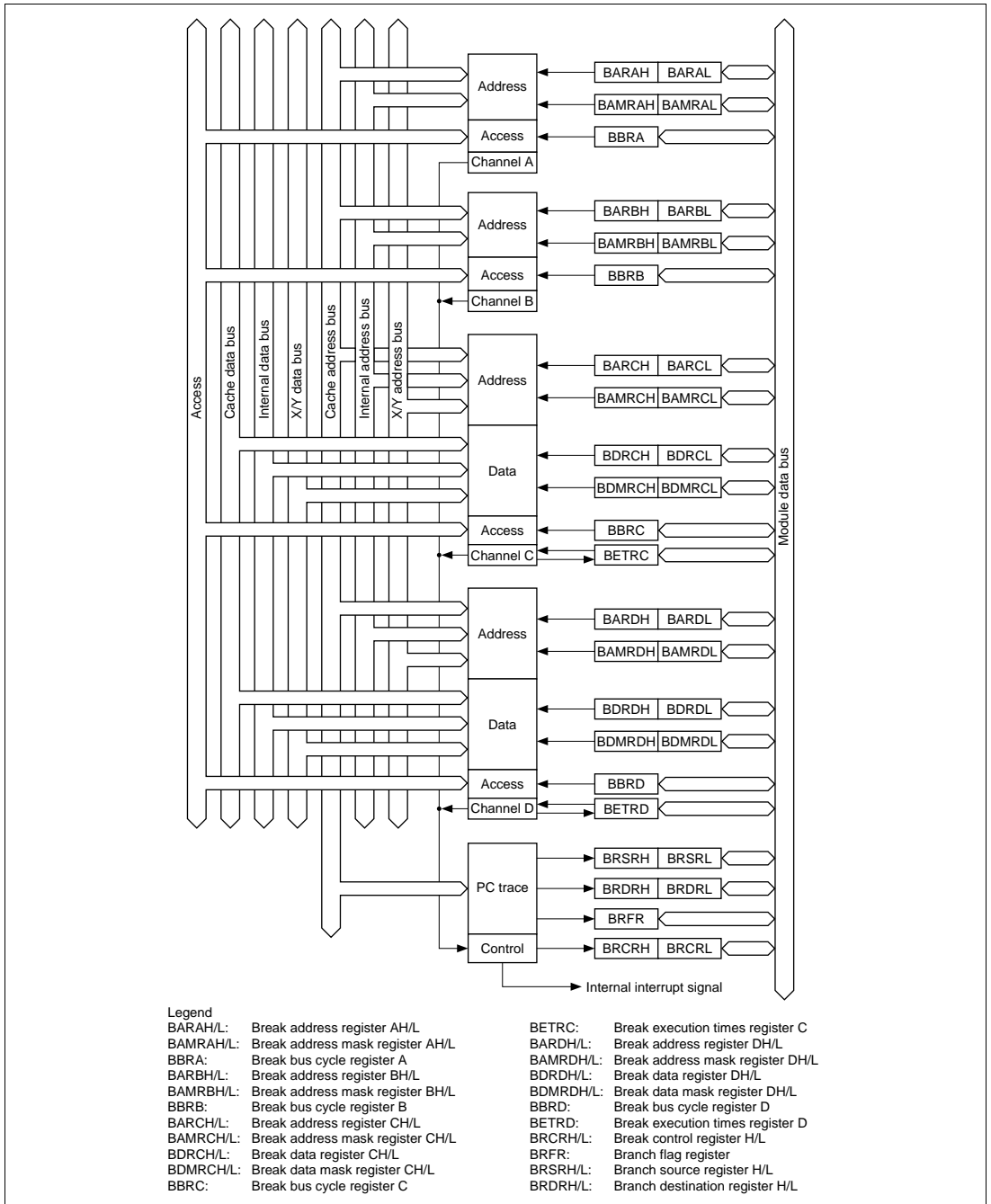

Figure 6.1 Block Diagram of User Break Controller

6.1.3 Register Configuration

Table 6.1 UBC Registers

Name	Abbreviation	R/W	Initial Value* ¹	Address	Access Size* ²	
Break address register AH	BARAH	R/W	H'0000	H'FFFFFF00	16	32
Break address register AL	BARAL	R/W	H'0000	H'FFFFFF02	16	
Break address mask register AH	BAMRAH	R/W	H'0000	H'FFFFFF04	16	32
Break address mask register AL	BAMRAL	R/W	H'0000	H'FFFFFF06	16	
Break bus cycle register A	BBRA	R/W	H'0000	H'FFFFFF08	16, 32	
Break address register BH	BARBH	R/W	H'0000	H'FFFFFF20	16	32
Break address register BL	BARBL	R/W	H'0000	H'FFFFFF22	16	
Break address mask register BH	BAMRBH	R/W	H'0000	H'FFFFFF24	16	32
Break address mask register BL	BAMRBL	R/W	H'0000	H'FFFFFF26	16	
Break bus cycle register B	BBRB	R/W	H'0000	H'FFFFFF28	16, 32	
Break address register CH	BARCH	R/W	H'0000	H'FFFFFF40	16	32
Break address register CL	BARCL	R/W	H'0000	H'FFFFFF42	16	
Break address mask register CH	BAMRCH	R/W	H'0000	H'FFFFFF44	16	32
Break address mask register CL	BAMRCL	R/W	H'0000	H'FFFFFF46	16	
Break data register CH	BDRCH	R/W	H'0000	H'FFFFFF50	16	32
Break data register CL	BDRCL	R/W	H'0000	H'FFFFFF52	16	
Break data mask register CH	BDMRCH	R/W	H'0000	H'FFFFFF54	16	32
Break data mask register CL	BDMRCL	R/W	H'0000	H'FFFFFF56	16	
Break bus cycle register C	BBRC	R/W	H'0000	H'FFFFFF48	16, 32	
Break execution times register C	BETRC	R/W	H'0000	H'FFFFFF58	16, 32	
Break address register DH	BARDH	R/W	H'0000	H'FFFFFF60	16	32
Break address register DL	BARDL	R/W	H'0000	H'FFFFFF62	16	
Break address mask register DH	BAMRDH	R/W	H'0000	H'FFFFFF64	16	32
Break address mask register DL	BAMRDL	R/W	H'0000	H'FFFFFF66	16	
Break data register DH	BDRDH	R/W	H'0000	H'FFFFFF70	16	32
Break data register DL	BDRDL	R/W	H'0000	H'FFFFFF72	16	
Break data mask register DH	BDMRDH	R/W	H'0000	H'FFFFFF74	16	32
Break data mask register DL	BDMRDL	R/W	H'0000	H'FFFFFF76	16	

Table 6.1 UBC Registers (cont)

Name	Abbreviation	R/W	Initial Value* ¹	Address	Access Size* ²
Break bus cycle register D	BBRD	R/W	H'0000	H'FFFFFF68	16, 32
Break execution times register D	BETRD	R/W	H'0000	H'FFFFFF78	16, 32
Break control register H	BRCRH	R/W	H'0000	H'FFFFFF30	16, 32
Break control register L	BRCRL	R/W	H'0000	H'FFFFFF32	16
Branch flag register	BRFR	R	* ³	H'FFFFFF10	16, 32
Branch source register H	BRSRH	R	Undefined	H'FFFFFF14	16, 32
Branch source register L	BRSRL	R	Undefined	H'FFFFFF16	16
Branch destination register H	BRDRH	R	Undefined	H'FFFFFF18	16, 32
Branch destination register L	BRDRL	R	Undefined	H'FFFFFF1A	16

Notes: *1 Initialized by a power-on reset. Value is retained in standby mode, and is undefined after a manual reset.

*2 Byte access cannot be used.

*3 Bits SVF and DVF in BRFR are initialized by a power-on reset; the other bits in BRFR are not initialized.

6.2 Register Descriptions

6.2.1 Break Address Register A (BARA)

BARAH

Bit:	15	14	13	12	11	10	9	8
	BAA31	BAA30	BAA29	BAA28	BAA27	BAA26	BAA25	BAA24
Initial value:	0	0	0	0	0	0	0	0
R/W:	R/W	R/W	R/W	R/W	R/W	R/W	R/W	R/W

Bit:	7	6	5	4	3	2	1	0
	BAA23	BAA22	BAA21	BAA20	BAA19	BAA18	BAA17	BAA16
Initial value:	0	0	0	0	0	0	0	0
R/W:	R/W	R/W	R/W	R/W	R/W	R/W	R/W	R/W

BARAL

Bit:	15	14	13	12	11	10	9	8
	BAA15	BAA14	BAA13	BAA12	BAA11	BAA10	BAA9	BAA8
Initial value:	0	0	0	0	0	0	0	0
R/W:	R/W	R/W	R/W	R/W	R/W	R/W	R/W	R/W

Bit:	7	6	5	4	3	2	1	0
	BAA7	BAA6	BAA5	BAA4	BAA3	BAA2	BAA1	BAA0
Initial value:	0	0	0	0	0	0	0	0
R/W:	R/W	R/W	R/W	R/W	R/W	R/W	R/W	R/W

Break address register A (BARA) consists of two 16-bit readable/writable registers: break address register AH (BARAH) and break address register AL (BARAL). BARAH specifies the upper half (bits 31 to 16) of the address used as a channel A break condition, and BARAL specifies the lower half (bits 15 to 0). BARAH and BARAL are initialized to H'0000 by a power-on reset; after a manual reset, their values are undefined.

BARAH Bits 15 to 0—Break Address A31 to A16 (BAA31 to BAA16): These bits store the upper half (bits 31 to 16) of the address used as a channel A break condition.

BARAL Bits 15 to 0—Break Address A15 to A0 (BAA15 to BAA0): These bits store the lower half (bits 15 to 0) of the address used as a channel A break condition.

6.2.2 Break Address Mask Register A (BAMRA)

BAMRAH

Bit:	15	14	13	12	11	10	9	8
	BAMA31	BAMA30	BAMA29	BAMA28	BAMA27	BAMA26	BAMA25	BAMA24
Initial value:	0	0	0	0	0	0	0	0
R/W:	R/W	R/W	R/W	R/W	R/W	R/W	R/W	R/W
Bit:	7	6	5	4	3	2	1	0
	BAMA23	BAMA22	BAMA21	BAMA20	BAMA19	BAMA18	BAMA17	BAMA16
Initial value:	0	0	0	0	0	0	0	0
R/W:	R/W	R/W	R/W	R/W	R/W	R/W	R/W	R/W

BAMRAL

Bit:	15	14	13	12	11	10	9	8
	BAMA15	BAMA14	BAMA13	BAMA12	BAMA11	BAMA10	BAMA9	BAMA8
Initial value:	0	0	0	0	0	0	0	0
R/W:	R/W	R/W	R/W	R/W	R/W	R/W	R/W	R/W
Bit:	7	6	5	4	3	2	1	0
	BAMA7	BAMA6	BAMA5	BAMA4	BAMA3	BAMA2	BAMA1	BAMA0
Initial value:	0	0	0	0	0	0	0	0
R/W:	R/W	R/W	R/W	R/W	R/W	R/W	R/W	R/W

Break address mask register A (BAMRA) consists of two 16-bit readable/writable registers: break address mask register AH (BAMRAH) and break address mask register AL (BAMRAL).

BAMRAH specifies which bits of the break address set in BARAH are to be masked, and

BAMRAL specifies which bits of the break address set in BARAL are to be masked. BAMRAH and BAMRAL are initialized to H'0000 by a power-on reset; after a manual reset, their values are undefined.

BAMRAH Bits 15 to 0—Break Address Mask A31 to A16 (BAMA31 to BAMA16): These bits specify whether or not corresponding channel A break address bits 31 to 16 (BAA31 to BAA16) set in BARAH are to be masked.

BAMRAL Bits 15 to 0—Break Address Mask A15 to A0 (BAMA15 to BAMA0): These bits specify whether or not corresponding channel A break address bits 15 to 0 (BAA15 to BAA0) set in BARAL are to be masked.

Bit 31 to 0:

BAMAn	Description
0	Channel A break address bit BAA _n is included in break condition (Initial value)
1	Channel A break address bit BAA _n is masked, and not included in condition

Note: n = 31 to 0

6.2.3 Break Bus Cycle Register A (BBRA)

Bit:	15	14	13	12	11	10	9	8
	—	—	—	—	—	—	—	—
Initial value:	0	0	0	0	0	0	0	0
R/W:	R	R	R	R	R	R	R	R

Bit:	7	6	5	4	3	2	1	0
	CPA1	CPA0	IDA1	IDA0	RWA1	RWA0	SZA1	SZA0
Initial value:	0	0	0	0	0	0	0	0
R/W:	R/W	R/W	R/W	R/W	R/W	R/W	R/W	R/W

Break bus cycle register A (BBRA) is a 16-bit readable/writable register that sets four channel A break conditions: (1) CPU cycle/on-chip DMAC (DMAC, E-DMAC) cycle, (2) instruction fetch/data access, (3) read/write, and (4) operand size. BBRA is initialized to H'0000 by a power-on reset; after a manual reset, its value is undefined.

Bits 15 to 8—Reserved: These bits are always read as 0. The write value should always be 0.

Bits 7 and 6—CPU/DMAC, E-DMAC Cycle Select A (CPA1, CPA0): These bits specify whether a CPU cycle, or a DMAC or E-DMAC cycle, is to be selected as the bus cycle used as a channel A break condition.

Bit 7: CPA1	Bit 6: CPA0	Description
0	0	Channel A user break interrupt is not generated (Initial value)
	1	CPU cycle is selected as user break condition
1	0	DMAC or E-DMAC cycle is selected as user break condition
	1	CPU, DMAC, or E-DMAC cycle is selected as user break condition

Bits 5 and 4—Instruction Fetch/Data Access Select A (IDA1, IDA0): These bits specify whether an instruction fetch cycle or data access cycle is to be selected as the bus cycle used as a channel A break condition.

Bit 5: IDA1	Bit 4: IDA0	Description	
0	0	Channel A user break interrupt is not generated	(Initial value)
	1	Instruction fetch cycle is selected as break condition	
1	0	Data access cycle is selected as break condition	
	1	Instruction fetch cycle or data access cycle is selected as break condition	

Bits 3 and 2—Read/Write Select A (RWA1, RWA0): These bits specify whether a read cycle or write cycle is to be selected as the bus cycle used as a channel A break condition.

Bit 3: RWA1	Bit 2: RWA0	Description	
0	0	Channel A user break interrupt is not generated	(Initial value)
	1	Read cycle is selected as break condition	
1	0	Write cycle is selected as break condition	
	1	Read cycle or write cycle is selected as break condition	

Bits 1 and 0—Operand Size Select A (SZA1, SZA0): These bits select the operand size of the bus cycle used as a channel A break condition.

Bit 1: SZA1	Bit 0: SZA0	Description	
0	0	Operand size is not included in break conditions	(Initial value)
	1	Byte access is selected as break condition	
1	0	Word access is selected as break condition	
	1	Longword access is selected as break condition	

Notes: When a break is to be executed on an instruction fetch, clear the SZA0 bit to 0. All instructions are regarded as being accessed using word size (instruction fetches are always performed as longword).

In the case of an instruction, the operand size is word; in the case of a CPU/DMAC, E-DMAC data access, it is determined by the specified operand size. Note that the operand size is not determined by the bus width of the space accessed.

6.2.4 Break Address Register B (BARB)

BARBH

Bit:	15	14	13	12	11	10	9	8
	BAB31	BAB30	BAB29	BAB28	BAB27	BAB26	BAB25	BAB24
Initial value:	0	0	0	0	0	0	0	0
R/W:	R/W	R/W	R/W	R/W	R/W	R/W	R/W	R/W
Bit:	7	6	5	4	3	2	1	0
	BAB23	BAB22	BAB21	BAB20	BAB19	BAB18	BAB17	BAB16
Initial value:	0	0	0	0	0	0	0	0
R/W:	R/W	R/W	R/W	R/W	R/W	R/W	R/W	R/W

BARBL

Bit:	15	14	13	12	11	10	9	8
	BAB15	BAB14	BAB13	BAB12	BAB11	BAB10	BAB9	BAB8
Initial value:	0	0	0	0	0	0	0	0
R/W:	R/W	R/W	R/W	R/W	R/W	R/W	R/W	R/W
Bit:	7	6	5	4	3	2	1	0
	BAB7	BAB6	BAB5	BAB4	BAB3	BAB2	BAB1	BAB0
Initial value:	0	0	0	0	0	0	0	0
R/W:	R/W	R/W	R/W	R/W	R/W	R/W	R/W	R/W

Break address register B (BARB) consists of two 16-bit readable/writable registers: break address register BH (BARBH) and break address register BL (BARBL). BARBH specifies the upper half (bits 31 to 16) of the address used as a channel B break condition, and BARBL specifies the lower half (bits 15 to 0). BARBH and BARBL are initialized to H'0000 by a power-on reset; after a manual reset, their values are undefined.

BARBH Bits 15 to 0—Break Address B31 to B16 (BAB31 to BAB16): These bits store the upper half (bits 31 to 16) of the address used as a channel B break condition.

BARBL Bits 15 to 0—Break Address B15 to B0 (BAB15 to BAB0): These bits store the lower half (bits 15 to 0) of the address used as a channel B break condition.

6.2.5 Break Address Mask Register B (BAMRB)

BAMRBH

Bit:	15	14	13	12	11	10	9	8
	BAMB31	BAMB30	BAMB29	BAMB28	BAMB27	BAMB26	BAMB25	BAMB24
Initial value:	0	0	0	0	0	0	0	0
R/W:	R/W	R/W	R/W	R/W	R/W	R/W	R/W	R/W
Bit:	7	6	5	4	3	2	1	0
	BAMB23	BAMB22	BAMB21	BAMB20	BAMB19	BAMB18	BAMB17	BAMB16
Initial value:	0	0	0	0	0	0	0	0
R/W:	R/W	R/W	R/W	R/W	R/W	R/W	R/W	R/W

BAMRBL

Bit:	15	14	13	12	11	10	9	8
	BAMB15	BAMB14	BAMB13	BAMB12	BAMB11	BAMB10	BAMB9	BAMB8
Initial value:	0	0	0	0	0	0	0	0
R/W:	R/W	R/W	R/W	R/W	R/W	R/W	R/W	R/W
Bit:	7	6	5	4	3	2	1	0
	BAMB7	BAMB6	BAMB5	BAMB4	BAMB3	BAMB2	BAMB1	BAMB0
Initial value:	0	0	0	0	0	0	0	0
R/W:	R/W	R/W	R/W	R/W	R/W	R/W	R/W	R/W

Break address mask register B (BAMRB) consists of two 16-bit readable/writable registers: break address mask register BH (BAMRBH) and break address mask register BL (BAMRBL).

BAMRBH specifies which bits of the break address set in BARBH are to be masked, and

BAMRBL specifies which bits of the break address set in BARBL are to be masked. BAMRBH and BAMRBL are initialized to H'0000 by a power-on reset; after a manual reset, their values are undefined.

BAMRBH Bits 15 to 0—Break Address Mask B31 to B16 (BAMB31 to BAMB16): These bits specify whether or not corresponding channel B break address bits 31 to 16 (BAB31 to BAB16) set in BARBH are to be masked.

BAMRBL Bits 15 to 0—Break Address Mask B15 to B0 (BAMB15 to BAMB0): These bits specify whether or not corresponding channel B break address bits 15 to 0 (BAB15 to BAB0) set in BARBL are to be masked.

Bit 31 to 0:

BAMBn	Description
0	Channel B break address bit BABn is included in break condition (Initial value)
1	Channel B break address bit BABn is masked, and not included in condition

Note: n = 31 to 0

6.2.6 Break Bus Cycle Register B (BBRB)

Bit:	15	14	13	12	11	10	9	8
	—	—	—	—	—	—	—	—
Initial value:	0	0	0	0	0	0	0	0
R/W:	R	R	R	R	R	R	R	R

Bit:	7	6	5	4	3	2	1	0
	CPB1	CPB0	IDB1	IDB0	RWB1	RWB0	SZB1	SZB0
Initial value:	0	0	0	0	0	0	0	0
R/W:	R/W	R/W	R/W	R/W	R/W	R/W	R/W	R/W

Break bus cycle register B (BBRB) is a 16-bit readable/writable register that sets four channel B break conditions: (1) CPU cycle/on-chip DMAC (DMAC, E-DMAC) cycle, (2) instruction fetch/data access, (3) read/write, and (4) operand size. BBRB is initialized to H'0000 by a power-on reset; after a manual reset, its value is undefined.

Bits 15 to 8—Reserved: These bits are always read as 0. The write value should always be 0.

Bits 7 and 6—CPU/DMAC, E-DMAC Cycle Select B (CPB1, CPB0): These bits specify whether a CPU cycle, or a DMAC or E-DMAC cycle, is to be selected as the bus cycle used as a channel B break condition.

Bit 7: CPB1	Bit 6: CPB0	Description
0	0	Channel B user break interrupt is not generated (Initial value)
	1	CPU cycle is selected as user break condition
1	0	DMAC or E-DMAC cycle is selected as user break condition
	1	CPU, DMAC, or E-DMAC cycle is selected as user break condition

Bits 5 and 4—Instruction Fetch/Data Access Select B (IDB1, IDB0): These bits specify whether an instruction fetch cycle or data access cycle is to be selected as the bus cycle used as a channel B break condition.

Bit 5: IDB1	Bit 4: IDB0	Description	
0	0	Channel B user break interrupt is not generated	(Initial value)
	1	Instruction fetch cycle is selected as break condition	
1	0	Data access cycle is selected as break condition	
	1	Instruction fetch cycle or data access cycle is selected as break condition	

Bits 3 and 2—Read/Write Select B (RWB1, RWB0): These bits specify whether a read cycle or write cycle is to be selected as the bus cycle used as a channel B break condition.

Bit 3: RWB1	Bit 2: RWB0	Description	
0	0	Channel B user break interrupt is not generated	(Initial value)
	1	Read cycle is selected as break condition	
1	0	Write cycle is selected as break condition	
	1	Read cycle or write cycle is selected as break condition	

Bits 1 and 0—Operand Size Select B (SZB1, SZB0): These bits select the operand size of the bus cycle used as a channel B break condition.

Bit 1: SZB1	Bit 0: SZB0	Description	
0	0	Operand size is not included in break conditions	(Initial value)
	1	Byte access is selected as break condition	
1	0	Word access is selected as break condition	
	1	Longword access is selected as break condition	

Notes: When a break is to be executed on an instruction fetch, clear the SZB0 bit to 0. All instructions are regarded as being accessed using word size (instruction fetches are always performed as longword).

In the case of an instruction, the operand size is word; in the case of a CPU/DMAC, E-DMAC data access, it is determined by the specified operand size. Note that the operand size is not determined by the bus width of the space accessed.

6.2.7 Break Address Register C (BARC)

BARCH

Bit:	15	14	13	12	11	10	9	8
	BAC31	BAC30	BAC29	BAC28	BAC27	BAC26	BAC25	BAC24
Initial value:	0	0	0	0	0	0	0	0
R/W:	R/W	R/W	R/W	R/W	R/W	R/W	R/W	R/W
Bit:	7	6	5	4	3	2	1	0
	BAC23	BAC22	BAC21	BAC20	BAC19	BAC18	BAC17	BAC16
Initial value:	0	0	0	0	0	0	0	0
R/W:	R/W	R/W	R/W	R/W	R/W	R/W	R/W	R/W

BARCL

Bit:	15	14	13	12	11	10	9	8
	BAC15	BAC14	BAC13	BAC12	BAC11	BAC10	BAC9	BAC8
Initial value:	0	0	0	0	0	0	0	0
R/W:	R/W	R/W	R/W	R/W	R/W	R/W	R/W	R/W
Bit:	7	6	5	4	3	2	1	0
	BAC7	BAC6	BAC5	BAC4	BAC3	BAC2	BAC1	BAC0
Initial value:	0	0	0	0	0	0	0	0
R/W:	R/W	R/W	R/W	R/W	R/W	R/W	R/W	R/W

Break address register C (BARC) consists of two 16-bit readable/writable registers: break address register CH (BARCH) and break address register CL (BARCL). BARCH specifies the upper half (bits 31 to 16) of the address used as a channel C break condition, and BARCL specifies the lower half (bits 15 to 0). The address bus connected to the X/Y memory can also be specified as a break condition by making a setting in the XYEC bit/XYSC bit in break bus cycle register C (BBRC). When XYEC = 0, BAC31 to BAC0 specify the address. When XYEC = 1, the upper 16 bits (BAC31 to BAC16) of BARC specify the X address bus, and the lower 16 bits (BAC15 to BAC0) specify the Y address bus. BARCH and BARCL are initialized to H'0000 by a power-on reset; after a manual reset, their values are undefined.

BARC Configuration

		Upper 16 Bits (BAC31 to BAC16)	Lower 16 Bits (BAC15 to BAC0)
XYEC = 0	Address	Upper 16 bits of address bus	Lower 16 bits of address bus
XYEC = 1	X address (when XYSC = 0)	X address (XAB15 to XAB1)*	—
	Y address (when XYSC = 1)	—	Y address (YAB15 to YAB1)*

Note: * As an X/Y bus access is always a word access, the values of XAB0 and YAB0 is not included in the break condition.

6.2.8 Break Address Mask Register C (BAMRC)

BAMRCH

Bit:	15	14	13	12	11	10	9	8
	BAMC31	BAMC30	BAMC29	BAMC28	BAMC27	BAMC26	BAMC25	BAMC24
Initial value:	0	0	0	0	0	0	0	0
R/W:	R/W	R/W	R/W	R/W	R/W	R/W	R/W	R/W

Bit:	7	6	5	4	3	2	1	0
	BAMC23	BAMC22	BAMC21	BAMC20	BAMC19	BAMC18	BAMC17	BAMC16
Initial value:	0	0	0	0	0	0	0	0
R/W:	R/W	R/W	R/W	R/W	R/W	R/W	R/W	R/W

BAMRCL

Bit:	15	14	13	12	11	10	9	8
	BAMC15	BAMC14	BAMC13	BAMC12	BAMC11	BAMC10	BAMC9	BAMC8
Initial value:	0	0	0	0	0	0	0	0
R/W:	R/W	R/W	R/W	R/W	R/W	R/W	R/W	R/W

Bit:	7	6	5	4	3	2	1	0
	BAMC7	BAMC6	BAMC5	BAMC4	BAMC3	BAMC2	BAMC1	BAMC0
Initial value:	0	0	0	0	0	0	0	0
R/W:	R/W	R/W	R/W	R/W	R/W	R/W	R/W	R/W

Break address mask register C (BAMRC) consists of two 16-bit readable/writable registers: break address mask register CH (BAMRCH) and break address mask register CL (BAMRCL). BAMRCH specifies which bits of the break address set in BARCH are to be masked, and BAMRCL specifies which bits of the break address set in BARCL are to be masked. Operation also depends on bits XYEC and XYSC in BBRC as shown below.

BAMRC Configuration

		Upper 16 Bits (BAMC31 to BAMC16)	Lower 16 Bits (BAMC15 to BAMC0)
XYEC = 0	Address	Upper 16 bits maskable	Lower 16 bits maskable
XYEC = 1	X address (when XYSC = 0)	Maskable	—
	Y address (when XYSC = 1)	—	Maskable

Bit 31 to 0:

BAMCn	Description
0	Channel C break address bit BACn is included in break condition (Initial value)
1	Channel C break address bit BACn is masked, and not included in condition

Note: n = 31 to 0

6.2.9 Break Data Register C (BDRC)

BDRCH

Bit:	15	14	13	12	11	10	9	8
	BDC31	BDC30	BDC29	BDC28	BDC27	BDC26	BDC25	BDC24
Initial value:	0	0	0	0	0	0	0	0
R/W:	R/W	R/W	R/W	R/W	R/W	R/W	R/W	R/W
Bit:	7	6	5	4	3	2	1	0
	BDC23	BDC22	BDC21	BDC20	BDC19	BDC18	BDC17	BDC16
Initial value:	0	0	0	0	0	0	0	0
R/W:	R/W	R/W	R/W	R/W	R/W	R/W	R/W	R/W

BDRCL

Bit:	15	14	13	12	11	10	9	8
	BDC15	BDC14	BDC13	BDC12	BDC11	BDC10	BDC9	BDC8
Initial value:	0	0	0	0	0	0	0	0
R/W:	R/W	R/W	R/W	R/W	R/W	R/W	R/W	R/W
Bit:	7	6	5	4	3	2	1	0
	BDC7	BDC6	BDC5	BDC4	BDC3	BDC2	BDC1	BDC0
Initial value:	0	0	0	0	0	0	0	0
R/W:	R/W	R/W	R/W	R/W	R/W	R/W	R/W	R/W

Break data register C (BDRC) consists of two 16-bit readable/writable registers: break data register CH (BDRCH) and break data register CL (BDRCL). BDRCH specifies the upper half (bits 31 to 16) of the data used as a channel C break condition, and BDRCL specifies the lower half (bits 15 to 0). The data bus connected to the X/Y memory can also be specified as a break condition by making a setting in the XYEC bit/XYSC bit in break bus cycle register C (BBRC). When XYEC = 1, the upper 16 bits (BDC31 to BDC16) of BDRC specify the X data bus, and the lower 16 bits (BDC15 to BDC0) specify the Y data bus.

BDRC Configuration

		Upper 16 Bits (BDC31 to BDC16)	Lower 16 Bits (BDC15 to BDC0)
XYEC = 0	Data	Upper 16 bits of data bus	Lower 16 bits of data bus
XYEC = 1	X data (when XYSC = 0)	X data (XDB15 to XDB0)	—
	Y data (when XYSC = 1)	—	Y data (YDB15 to YDB0)

6.2.10 Break Data Mask Register C (BDMRC)

BDMRCH

Bit:	15	14	13	12	11	10	9	8
	BDMC31	BDMC30	BDMC29	BDMC28	BDMC27	BDMC26	BDMC25	BDMC24
Initial value:	0	0	0	0	0	0	0	0
R/W:	R/W	R/W	R/W	R/W	R/W	R/W	R/W	R/W

Bit:	7	6	5	4	3	2	1	0
	BDMC23	BDMC22	BDMC21	BDMC20	BDMC19	BDMC18	BDMC17	BDMC16
Initial value:	0	0	0	0	0	0	0	0
R/W:	R/W	R/W	R/W	R/W	R/W	R/W	R/W	R/W

BDMRCL

Bit:	15	14	13	12	11	10	9	8
	BDMC15	BDMC14	BDMC13	BDMC12	BDMC11	BDMC10	BDMC9	BDMC8
Initial value:	0	0	0	0	0	0	0	0
R/W:	R/W	R/W	R/W	R/W	R/W	R/W	R/W	R/W

Bit:	7	6	5	4	3	2	1	0
	BDMC7	BDMC6	BDMC5	BDMC4	BDMC3	BDMC2	BDMC1	BDMC0
Initial value:	0	0	0	0	0	0	0	0
R/W:	R/W	R/W	R/W	R/W	R/W	R/W	R/W	R/W

Break data mask register C (BDMRC) consists of two 16-bit readable/writable registers: break data mask register CH (BDMRCH) and break data mask register CL (BDMRCL). BDMRCH specifies which bits of the break data set in BDRCH are to be masked, and BDMRCL specifies which bits of the break data set in BDRCL are to be masked. Operation also depends on bits

XYEC and XYSC in BBRC as shown below. BDMRCH and BDMRCL are initialized to H'0000 by a power-on reset; after a manual reset, their values are undefined.

BDMRC Configuration

		Upper 16 Bits (BDMC31 to BDMC16)	Lower 16 Bits (BDMC15 to BDMC0)
XYEC = 0	Data	Upper 16 bits maskable	Lower 16 bits maskable
XYEC = 1	X data (when XYSC = 0)	Maskable	—
	Y data (when XYSC = 1)	—	Maskable

Bit 31 to 0:

BDMCn	Description
0	Channel C break data bit BDCn is included in break condition (Initial value)
1	Channel C break data bit BDCn is masked, and not included in condition

Notes: 1. n = 31 to 0

2. When including the data bus value in the break condition, specify the operand size.
3. When specifying byte size, and using odd-address data as a break condition, set the value in bits 7 to 0 of BDRC and BDMRC. When using even-address data as a break condition, set the value in bits 15 to 8. The unused 8 bits of these registers have no effect on the break condition.

6.2.11 Break Bus Cycle Register C (BBRC)

Bit:	15	14	13	12	11	10	9	8
	—	—	—	—	—	—	XYEC	XYSC
Initial value:	0	0	0	0	0	0	0	0
R/W:	R	R	R	R	R	R	R/W	R/W
Bit:	7	6	5	4	3	2	1	0
	CPC1	CPC0	IDC1	IDC0	RWC1	RWC0	SZC1	SZC0
Initial value:	0	0	0	0	0	0	0	0
R/W:	R/W	R/W	R/W	R/W	R/W	R/W	R/W	R/W

Break bus cycle register C (BBRC) is a 16-bit readable/writable register that sets five channel C break conditions: (1) internal bus (C-bus, I-bus)/X memory bus/Y memory bus), (2) CPU cycle/on-chip DMAC (DMAC, E-DMAC) cycle, (3) instruction fetch/data access, (4) read/write, and (5) operand size. BBRC is initialized to H'0000 by a power-on reset; after a manual reset, its value is undefined.

Bits 15 to 10—Reserved: These bits are always read as 0. The write value should always be 0.

Bit 9—X/Y Memory Bus Enable C (XYEC): Selects whether the X/Y bus is used as a channel C break condition.

Bit 9: XYEC	Description
0	Cache bus or internal bus is selected as condition for channel C address/data (Initial value)
1	X/Y bus is selected as condition for channel C address/data

Bit 8—X Bus/Y Bus Select C (XYSC): Selects whether the X bus or the Y bus is used as a channel C break condition. This bit is valid only when bit XYEC = 1.

Bit 8: XYSC	Description
0	X bus is selected as channel C break condition (Initial value)
1	Y bus is selected as channel C break condition

The configuration of bits 7 to 0 is the same as for BBRA.

6.2.12 Break Execution Times Register C (BETRC)

Bit:	15	14	13	12	11	10	9	8
	—	—	—	—	ETRC11	ETRC10	ETRC9	ETRC8
Initial value:	0	0	0	0	0	0	0	0
R/W:	R	R	R	R	R/W	R/W	R/W	R/W

Bit:	7	6	5	4	3	2	1	0
	ETRC7	ETRC6	ETRC5	ETRC4	ETRC3	ETRC2	ETRC1	ETRC0
Initial value:	0	0	0	0	0	0	0	0
R/W:	R/W	R/W	R/W	R/W	R/W	R/W	R/W	R/W

When a channel C execution-times break condition is enabled (by setting the ETBEC bit in BRCCR), this 16-bit register specifies the number of times a channel C break condition occurs before a user break interrupt is requested. The maximum value is $2^{12} - 1$ times. Each time a channel C break condition occurs, the value in BETRC is decremented by 1. After the BETRC value reaches H'0001, an interrupt is requested when a break condition next occurs.

As exceptions and interrupts cannot be accepted for instructions in a repeat loop comprising no more than three instructions, BETRC is not decremented by the occurrence of a break condition for an instruction in such a repeat loop (see 4.6, When Exception Sources Are Not Accepted).

Bits 15 to 12 are always read as 0, and should only be written with 0.

BETRC is initialized to H'0000 by a power-on reset.

6.2.13 Break Address Register D (BARD)

BARDH

Bit	15	14	13	12	11	10	9	8
	BAD31	BAD30	BAD29	BAD28	BAD27	BAD26	BAD25	BAD24
Initial value	0	0	0	0	0	0	0	0
Read/Write	R/W	R/W	R/W	R/W	R/W	R/W	R/W	R/W

Bit	7	6	5	4	3	2	1	0
	BAD23	BAD22	BAD21	BAD20	BAD19	BAD18	BAD17	BAD16
Initial value	0	0	0	0	0	0	0	0
Read/Write	R/W	R/W	R/W	R/W	R/W	R/W	R/W	R/W

BARDL

Bit	15	14	13	12	11	10	9	8
	BAD15	BAD14	BAD13	BAD12	BAD11	BAD10	BAD9	BAD8
Initial value	0	0	0	0	0	0	0	0
Read/Write	R/W	R/W	R/W	R/W	R/W	R/W	R/W	R/W

Bit	7	6	5	4	3	2	1	0
	BAD7	BAD6	BAD5	BAD4	BAD3	BAD2	BAD1	BAD0
Initial value	0	0	0	0	0	0	0	0
Read/Write	R/W	R/W	R/W	R/W	R/W	R/W	R/W	R/W

Break address register D (BARD) consists of two 16-bit readable/writable registers: break address register DH (BARDH) and break address register DL (BARDL). BARDH specifies the upper half (bits 31 to 16) of the address used as a channel D break condition, and BARDL specifies the lower half (bits 15 to 0). The address bus connected to the X/Y memory can also be specified as a break condition by making a setting in the XYED bit/XYSD bit in break bus cycle register D (BBRD). When XYED = 0, BAD31 to BAD0 specify the address. When XYED = 1, the upper 16 bits (BAD31 to BAD16) of BARD specify the X address bus, and the lower 16 bits (BAD15 to BAD0) specify the Y address bus. BARDH and BARDL are initialized to H'0000 by a power-on reset; after a manual reset, their values are undefined.

BARD Configuration

		Upper 16 Bits (BAD31 to BAD16)	Lower 16 Bits (BAD15 to BAD0)
XYED = 0	Address	Upper 16 bits of address bus	Lower 16 bits of address bus
XYED = 1	X address (when XYSD = 0)	X address (XAB15 to XAB1)*	—
	Y address (when XYSD = 1)	—	Y address (YAB15 to YAB1)*

Note: * As an X/Y bus access is always a word access, the values of XAB0 and YAB0 is not included in the break condition.

6.2.14 Break Address Mask Register D (BAMRD)

BAMRDH

Bit:	15	14	13	12	11	10	9	8
	BAMD31	BAMD30	BAMD29	BAMD28	BAMD27	BAMD26	BAMD25	BAMD24
Initial value:	0	0	0	0	0	0	0	0
R/W:	R/W	R/W	R/W	R/W	R/W	R/W	R/W	R/W
Bit:	7	6	5	4	3	2	1	0
	BAMD23	BAMD22	BAMD21	BAMD20	BAMD19	BAMD18	BAMD17	BAMD16
Initial value:	0	0	0	0	0	0	0	0
R/W:	R/W	R/W	R/W	R/W	R/W	R/W	R/W	R/W

BAMRDL

Bit:	15	14	13	12	11	10	9	8
	BAMD15	BAMD14	BAMD13	BAMD12	BAMD11	BAMD10	BAMD9	BAMD8
Initial value:	0	0	0	0	0	0	0	0
R/W:	R/W	R/W	R/W	R/W	R/W	R/W	R/W	R/W
Bit:	7	6	5	4	3	2	1	0
	BAMD7	BAMD6	BAMD5	BAMD4	BAMD3	BAMD2	BAMD1	BAMD0
Initial value:	0	0	0	0	0	0	0	0
R/W:	R/W	R/W	R/W	R/W	R/W	R/W	R/W	R/W

Break address mask register D (BAMRD) consists of two 16-bit readable/writable registers: break address mask register DH (BAMRDH) and break address mask register DL (BAMRDL). BAMRDH specifies which bits of the break address set in BARDH are to be masked, and BAMRDL specifies which bits of the break address set in BARDL are to be masked. Operation also depends on bits XYED and XYSD in BBRD as shown below.

BAMRD Configuration

		Upper 16 Bits (BAMD31 to BAMD16)	Lower 16 Bits (BAMD15 to BAMD0)
XYED = 0	Address	Upper 16 bits maskable	Lower 16 bits maskable
XYED = 1	X address (when XYSD = 0)	Maskable	—
	Y address (when XYSD = 1)	—	Maskable

Bit 31 to 0:

BAMDn	Description
0	Channel D break address bit BADn is included in break condition (Initial value)
1	Channel D break address bit BADn is masked, and not included in condition

Note: n = 31 to 0

6.2.15 Break Data Register D (BDRD)

BDRDH

Bit:	15	14	13	12	11	10	9	8
	BDD31	BDD30	BDD29	BDD28	BDD27	BDD26	BDD25	BDD24
Initial value:	0	0	0	0	0	0	0	0
R/W:	R/W	R/W	R/W	R/W	R/W	R/W	R/W	R/W
Bit:	7	6	5	4	3	2	1	0
	BDD23	BDD22	BDD21	BDD20	BDD19	BDD18	BDD17	BDD16
Initial value:	0	0	0	0	0	0	0	0
R/W:	R/W	R/W	R/W	R/W	R/W	R/W	R/W	R/W

BDRDL

Bit:	15	14	13	12	11	10	9	8
	BDD15	BDD14	BDD13	BDD12	BDD11	BDD10	BDD9	BDD8
Initial value:	0	0	0	0	0	0	0	0
R/W:	R/W	R/W	R/W	R/W	R/W	R/W	R/W	R/W
Bit:	7	6	5	4	3	2	1	0
	BDD7	BDD6	BDD5	BDD4	BDD3	BDD2	BDD1	BDD0
Initial value:	0	0	0	0	0	0	0	0
R/W:	R/W	R/W	R/W	R/W	R/W	R/W	R/W	R/W

Break data register D (BDRD) consists of two 16-bit readable/writable registers: break data register DH (BDRDH) and break data register DL (BDRDL). BDRDH specifies the upper half (bits 31 to 16) of the data used as a channel D break condition, and BDRDL specifies the lower half (bits 15 to 0). The data bus connected to the X/Y memory can also be specified as a break condition by making a setting in the XYED bit/XYSD bit in break bus cycle register D (BBRD). When XYED = 1, the upper 16 bits (BDD31 to BDD16) of BDRD specify the X data bus, and the lower 16 bits (BDD15 to BDD0) specify the Y data bus.

BDRD Configuration

		Upper 16 Bits (BDD31 to BDD16)	Lower 16 Bits (BDD15 to BDD0)
XYED = 0	Data	Upper 16 bits of data bus	Lower 16 bits of data bus
XYED = 1	X data (when XYSD = 0)	X data (XDB15 to XDB0)	—
	Y data (when XYSD = 1)	—	Y data (YDB15 to YDB0)

6.2.16 Break Data Mask Register D (BDMRD)

BDMRDH

Bit:	15	14	13	12	11	10	9	8
	BDMD31	BDMD30	BDMD29	BDMD28	BDMD27	BDMD26	BDMD25	BDMD24
Initial value:	0	0	0	0	0	0	0	0
R/W:	R/W	R/W	R/W	R/W	R/W	R/W	R/W	R/W

Bit:	7	6	5	4	3	2	1	0
	BDMD23	BDMD22	BDMD21	BDMD20	BDMD19	BDMD18	BDMD17	BDMD16
Initial value:	0	0	0	0	0	0	0	0
R/W:	R/W	R/W	R/W	R/W	R/W	R/W	R/W	R/W

BDMRDL

Bit:	15	14	13	12	11	10	9	8
	BDMD15	BDMD14	BDMD13	BDMD12	BDMD11	BDMD10	BDMD9	BDMD8
Initial value:	0	0	0	0	0	0	0	0
R/W:	R/W	R/W	R/W	R/W	R/W	R/W	R/W	R/W

Bit:	7	6	5	4	3	2	1	0
	BDMD7	BDMD6	BDMD5	BDMD4	BDMD3	BDMD2	BDMD1	BDMD0
Initial value:	0	0	0	0	0	0	0	0
R/W:	R/W	R/W	R/W	R/W	R/W	R/W	R/W	R/W

Break data mask register D (BDMRD) consists of two 16-bit readable/writable registers: break data mask register DH (BDMRDH) and break data mask register DL (BDMRDL). BDMRDH specifies which bits of the break data set in BDRDH are to be masked, and BDMRDL specifies which bits of the break data set in BDRDL are to be masked. Operation also depends on bits

XYED and XYSD in BBRD as shown below. BDMRDH and BDMRDL are initialized to H'0000 by a power-on reset; after a manual reset, their values are undefined.

BDMRD Configuration

		Upper 16 Bits (BDMD31 to BDMD16)	Lower 16 Bits (BDMD15 to BDMD0)
XYED = 0	Data	Upper 16 bits maskable	Lower 16 bits maskable
XYED = 1	X data (when XYSD = 0)	Maskable	—
	Y data (when XYSD = 1)	—	Maskable

Bit 31 to 0:

BDMDn	Description
0	Channel D break data bit BDDn is included in break condition (Initial value)
1	Channel D break data bit BDDn is masked, and not included in condition

Notes: 1. n = 31 to 0

2. When including the data bus value in the break condition, specify the operand size.
3. When specifying byte size, and using odd-address data as a break condition, set the value in bits 7 to 0 of BDRD and BDMRD. When using even-address data as a break condition, set the value in bits 15 to 8. The unused 8 bits of these registers have no effect on the break condition.

6.2.17 Break Bus Cycle Register D (BBRD)

Bit:	15	14	13	12	11	10	9	8
	—	—	—	—	—	—	XYED	XYSD
Initial value:	0	0	0	0	0	0	0	0
R/W:	R	R	R	R	R	R	R/W	R/W
Bit:	7	6	5	4	3	2	1	0
	CPD1	CPD0	IDD1	IDD0	RWD1	RWD0	SZD1	SZD0
Initial value:	0	0	0	0	0	0	0	0
R/W:	R/W	R/W	R/W	R/W	R/W	R/W	R/W	R/W

Break bus cycle register D (BBRD) is a 16-bit readable/writable register that sets five channel D break conditions: (1) internal bus (C-bus, I-bus)/X memory bus/Y memory bus), (2) CPU cycle/on-chip DMAC (DMAC, E-DMAC) cycle, (3) instruction fetch/data access, (4) read/write, and (5) operand size. BBRD is initialized to H'0000 by a power-on reset; after a manual reset, its value is undefined.

Bits 15 to 10—Reserved: These bits are always read as 0. The write value should always be 0.

Bit 9—X/Y Memory Bus Enable D (XYED): Selects whether the X/Y bus is used as a channel D break condition.

Bit 9: XYED	Description
0	Cache bus or internal bus is selected as condition for channel D address/data (Initial value)
1	X/Y bus is selected as condition for channel D address/data

Bit 8—X Bus/Y Bus Select D (XYSD): Selects whether the X bus or the Y bus is used as a channel D break condition. This bit is valid only when bit XYED = 1.

Bit 8: XYSD	Description
0	X bus is selected as channel D break condition (Initial value)
1	Y bus is selected as channel D break condition

The configuration of bits 7 to 0 is the same as for BBRA.

6.2.18 Break Execution Times Register D (BETRD)

Bit:	15	14	13	12	11	10	9	8
	—	—	—	—	ETRD11	ETRD10	ETRD9	ETRD8
Initial value:	0	0	0	0	0	0	0	0
R/W:	R	R	R	R	R/W	R/W	R/W	R/W

Bit:	7	6	5	4	3	2	1	0
	ETRD7	ETRD6	ETRD5	ETRD4	ETRD3	ETRD2	ETRD1	ETRD0
Initial value:	0	0	0	0	0	0	0	0
R/W:	R/W	R/W	R/W	R/W	R/W	R/W	R/W	R/W

When a channel D execution-times break condition is enabled (by setting the ETBED bit in BRCCR), this 16-bit register specifies the number of times a channel D break condition occurs before a user break interrupt is requested. The maximum value is $2^{12} - 1$ times. Each time a channel D break condition occurs, the value in BETRD is decremented by 1. After the BETRD value reaches H'0001, an interrupt is requested when a break condition next occurs.

As exceptions and interrupts cannot be accepted for instructions in a repeat loop comprising no more than three instructions, BETRD is not decremented by the occurrence of a break condition for an instruction in such a repeat loop (see 4.6, When Exception Sources Are Not Accepted).

Bits 15 to 12 are always read as 0, and should only be written with 0.

BETRD is initialized to H'0000 by a power-on reset.

6.2.19 Break Control Register (BRCR)

BRCRH

Bit:	15	14	13	12	11	10	9	8
	CMFCA	CMFPA	—	—	PCTE	PCBA	—	—
Initial value:	0	0	0	0	0	0	0	0
R/W:	R/W	R/W	R/W	R/W	R/W	R/W	R/W	R/W
Bit:	7	6	5	4	3	2	1	0
	CMFCB	CMFPB	—	SEQ1	SEQ0	PCBB	—	—
Initial value:	0	0	0	0	0	0	0	0
R/W:	R/W	R/W	R/W	R/W	R/W	R/W	R/W	R/W

BRCRL

Bit:	15	14	13	12	11	10	9	8
	CMFCC	CMFPC	ETBEC	—	DBEC	PCBC	—	—
Initial value:	0	0	0	0	0	0	0	0
R/W:	R/W	R/W	R/W	R/W	R/W	R/W	R/W	R/W
Bit:	7	6	5	4	3	2	1	0
	CMFCD	CMFPD	ETBED	—	DBED	PCBD	—	—
Initial value:	0	0	0	0	0	0	0	0
R/W:	R/W	R/W	R/W	R/W	R/W	R/W	R/W	R/W

The break control register (BRCR) is used to make the following settings:

1. Setting of independent channel mode or sequential condition mode for channels A, B, C, and D
2. Selection of pre- or post-instruction-execution break in case of an instruction fetch cycle
3. Selection of whether the data bus is to be included in the comparison conditions for channels C and D
4. Selection of whether an execution-times break is to be set for channels C and D
5. Selection of whether a PC trace is to be executed

BRCR also contains flags that are set when a condition is satisfied. BRCR is initialized to H'00000000 by a power-on reset; after a manual reset, its value is undefined.

Bit 31—CPU Condition Match Flag A (CMFCA): This flag is set to 1 when a CPU bus cycle condition, among the break conditions set for channel A, is satisfied. This flag is not cleared to 0 (if the flag setting is to be checked again after it has once been set, the flag must be cleared by a write).

Bit 31: CMFCA **Description**

0	User break interrupt has not been generated by a channel A CPU cycle condition	(Initial value)
1	User break interrupt has been generated by a channel A CPU cycle condition	

Bit 30—DMAC Condition Match Flag A (CMFPA): This flag is set to 1 when an on-chip DMAC bus cycle condition, among the break conditions set for channel A, is satisfied. This flag is not cleared to 0 (if the flag setting is to be checked again after it has once been set, the flag must be cleared by a write).

Bit 30: CMFPA **Description**

0	User break interrupt has not been generated by a channel A on-chip DMAC cycle condition	(Initial value)
1	User break interrupt has been generated by a channel A on-chip DMAC cycle condition	

Bits 29 and 28—Reserved: These bits are always read as 0. The write value should always be 0.

Bit 27—PC Trace Enable (PCTE): Selects whether a PC trace is to be executed.

Bit 27: PCTE **Description**

0	PC trace is not executed	(Initial value)
1	PC trace is executed	

Bit 26—PC Break Select A (PCBA): Selects whether a channel A instruction fetch cycle break is effected before or after execution of the instruction.

Bit 26: PCBA **Description**

0	Channel A instruction fetch cycle break is effected before instruction execution	(Initial value)
1	Channel A instruction fetch cycle break is effected after instruction execution	

Bits 25 and 24—Reserved: These bits are always read as 0. The write value should always be 0.

Bit 23—CPU Condition Match Flag B (CMFCB): This flag is set to 1 when a CPU bus cycle condition, among the break conditions set for channel B, is satisfied. This flag is not cleared to 0 (if the flag setting is to be checked again after it has once been set, the flag must be cleared by a write).

Bit 23: CMFCB	Description
0	User break interrupt has not been generated by a channel B CPU cycle condition (Initial value)
1	User break interrupt has been generated by a channel B CPU cycle condition

Bit 22—DMAC Condition Match Flag B (CMFPB): This flag is set to 1 when an on-chip DMAC bus cycle condition, among the break conditions set for channel B, is satisfied. This flag is not cleared to 0 (if the flag setting is to be checked again after it has once been set, the flag must be cleared by a write).

Bit 22: CMFPB	Description
0	User break interrupt has not been generated by a channel B on-chip DMAC cycle condition (Initial value)
1	User break interrupt has been generated by a channel B on-chip DMAC cycle condition

Bit 21—Reserved: This bit is always read as 0. The write value should always be 0.

Bits 20 and 19—Sequence Condition Select (SEQ1, SEQ0): These bits select independent or sequential conditions for channels A, B, C, and D.

Bit 20: SEQ1	Bit 19: SEQ0	Description
0	0	Comparison based on independent conditions for channels A, B, C, and D (Initial value)
	1	Channel C → D sequential condition; channels A and B independent
1	0	Channel B → C → D sequential condition; channel A independent
	1	Channel A → B → C → D sequential condition

Bit 18—PC Break Select B (PCBB): Selects whether a channel B instruction fetch cycle break is effected before or after execution of the instruction.

Bit 18: PCBB	Description
0	Channel B instruction fetch cycle break is effected before instruction execution (Initial value)
1	Channel B instruction fetch cycle break is effected after instruction execution

Bits 17 and 16—Reserved: These bits are always read as 0. The write value should always be 0.

Bit 15—CPU Condition Match Flag C (CMFCC): This flag is set to 1 when a CPU bus cycle condition, among the break conditions set for channel C, is satisfied. This flag is not cleared to 0 (if the flag setting is to be checked again after it has once been set, the flag must be cleared by a write).

Bit 15: CMFCC	Description
0	User break interrupt has not been generated by a channel C CPU cycle condition (Initial value)
1	User break interrupt has been generated by a channel C CPU cycle condition

Bit 14—DMAC Condition Match Flag C (CMFPC): This flag is set to 1 when an on-chip DMAC bus cycle condition, among the break conditions set for channel C, is satisfied. This flag is not cleared to 0 (if the flag setting is to be checked again after it has once been set, the flag must be cleared by a write).

Bit 14: CMFPC	Description
0	User break interrupt has not been generated by a channel C on-chip DMAC cycle condition (Initial value)
1	User break interrupt has been generated by a channel C on-chip DMAC cycle condition

Bit 13—Execution-Times Break Enable C (ETBEC): Enables a channel C execution-times break condition. When this bit is 1, a user break interrupt is generated when the number of break conditions that have occurred equals the number of executions specified by the break execution times register (BETRC).

Bit 13: ETBEC	Description
0	Channel C execution-times break condition is disabled (Initial value)
1	Channel C execution-times break condition is enabled

Bit 12—Reserved: This bit is always read as 0. The write value should always be 0.

Bit 11—Data Break Enable C (DBEC): Selects whether a data bus condition is to be included in the channel C break conditions.

Bit 11: DBEC	Description
0	Data bus condition is not included in channel C conditions (Initial value)
1	Data bus condition is included in channel C conditions

Bit 10—PC Break Select C (PCBC): Selects whether a channel C instruction fetch cycle break is effected before or after execution of the instruction.

Bit 10: PCBC	Description
0	Channel C instruction fetch cycle break is effected before instruction execution (Initial value)
1	Channel C instruction fetch cycle break is effected after instruction execution

Bits 9 and 8—Reserved: These bits are always read as 0. The write value should always be 0.

Bit 7—CPU Condition Match Flag D (CMFCD): This flag is set to 1 when a CPU bus cycle condition, among the break conditions set for channel D, is satisfied. This flag is not cleared to 0 (if the flag setting is to be checked again after it has once been set, the flag must be cleared by a write).

Bit 7: CMFCD	Description
0	User break interrupt has not been generated by a channel D CPU cycle condition (Initial value)
1	User break interrupt has been generated by a channel D CPU cycle condition

Bit 6—DMAC Condition Match Flag D (CMFPD): This flag is set to 1 when a DMAC bus cycle condition, among the break conditions set for channel D, is satisfied. This flag is not cleared to 0 (if the flag setting is to be checked again after it has once been set, the flag must be cleared by a write).

Bit 6: CMFPD	Description
0	User break interrupt has not been generated by a channel D on-chip DMAC cycle condition (Initial value)
1	User break interrupt has been generated by a channel D on-chip DMAC cycle condition

Bit 5—Execution-Times Break Enable D (ETBED): Enables a channel D execution-times break condition. When this bit is 1, a user break interrupt is generated when the number of break conditions that have occurred equals the number of executions specified by the break execution times register (BETRD).

Bit 5: ETBED	Description
0	Channel D execution-times break condition is disabled (Initial value)
1	Channel D execution-times break condition is enabled

Bit 4—Reserved: This bit is always read as 0. The write value should always be 0.

Bit 3—Data Break Enable D (DBED): Selects whether a data bus condition is to be included in the channel D break conditions.

Bit 3: DBED	Description
0	Data bus condition is not included in channel D conditions (Initial value)
1	Data bus condition is included in channel D conditions

Bit 2—PC Break Select D (PCBD): Selects whether a channel D instruction fetch cycle break is effected before or after execution of the instruction.

Bit 2: PCBD	Description
0	Channel D instruction fetch cycle break is effected before instruction execution (Initial value)
1	Channel D instruction fetch cycle break is effected after instruction execution

Bits 1 and 0—Reserved: These bits are always read as 0. The write value should always be 0.

6.2.20 Branch Flag Registers (BRFR)

Bit:	15	14	13	12	11	10	9	8
	SVF	PID2	PID1	PID0	—	—	—	—
Initial value:	0	Undefined	Undefined	Undefined	0	0	0	0
R/W:	R	R	R	R	R	R	R	R
Bit:	7	6	5	4	3	2	1	0
	DVF	—	—	—	—	—	—	—
Initial value:	0	0	0	0	0	0	0	0
R/W:	R	R	R	R	R	R	R	R

The branch flag registers (BRFR) comprise a set of four 16-bit read-only registers. The BRFR registers contain flags indicating whether the actual branch addresses (in a branch instruction, repeat, interrupt, etc.) have been saved in BRSR and BRDR, and a 3-bit pointer indicating the number of cycles from fetch to execution of the last instruction executed. The BRFR registers form a FIFO (first-in first-out) queue for PC trace use. The queue is shifted at each branch.

Bits SVF and DVF are initialized by a power-on reset, but bits PID2 to PID0 are not.

Bit 15—Source Verify Flag (SVF): Indicates whether the address and pointer that enable the branch source address to be calculated have been stored in BRSR. This flag is set when the instruction at the branch destination address is fetched, and reset when BRSR is read.

Bit 15: SVF	Description
0	BRSR value is invalid (Initial value)
1	BRSR value is valid

Bits 14 to 12—PID2 to PID0: These bits comprise a pointer that indicates the instruction buffer number of the instruction executed immediately before a branch occurred.

Bits 14 to 12: PID2 to PID0	Description
Odd	PID indicates instruction buffer number (Initial value)
Even	PID+2 indicates instruction buffer number

Bits 11 to 8, 6 to 0—Reserved: These bits are always read as 0. The write value should always be 0.

Bit 7—Destination Verify Flag (DVF): Indicates whether the branch source address has been stored in BRDR. This flag is set when the instruction at the branch destination address is fetched, and reset when BRDR is read.

Bit 7: DVF	Description
0	BRDR value is invalid (Initial value)
1	BRDR value is valid

See the PC trace description for the method of executing a PC trace using the branch source registers (BRSR), branch destination registers (BRDR), and branch flag registers (BRFR).

6.2.21 Branch Source Registers (BRSR)

BRSRH

Bit:	15	14	13	12	11	10	9	8
	BSA31	BSA30	BSA29	BSA28	BSA27	BSA26	BSA25	BSA24
Initial value:	Undefined	Undefined	Undefined	Undefined	Undefined	Undefined	Undefined	Undefined
R/W:	R	R	R	R	R	R	R	R
Bit:	7	6	5	4	3	2	1	0
	BSA23	BSA22	BSA21	BSA20	BSA19	BSA18	BSA17	BSA16
Initial value:	Undefined	Undefined	Undefined	Undefined	Undefined	Undefined	Undefined	Undefined
R/W:	R	R	R	R	R	R	R	R

BRSRL

Bit:	15	14	13	12	11	10	9	8
	BSA15	BSA14	BSA13	BSA12	BSA11	BSA10	BSA9	BSA8
Initial value:	Undefined	Undefined	Undefined	Undefined	Undefined	Undefined	Undefined	Undefined
R/W:	R	R	R	R	R	R	R	R
Bit:	7	6	5	4	3	2	1	0
	BSA7	BSA6	BSA5	BSA4	BSA3	BSA2	BSA1	BSA0
Initial value:	Undefined	Undefined	Undefined	Undefined	Undefined	Undefined	Undefined	Undefined
R/W:	R	R	R	R	R	R	R	R

The branch source registers (BRSR) comprise a set of four 32-bit read-only registers. The values in these registers are used to calculate the address of the last instruction executed before a branch

when performing a PC trace. The BRSR registers form a FIFO (first-in first-out) queue for PC trace use. The queue is shifted at each branch.

The BRSR registers are not initialized by a reset.

6.2.22 Branch Destination Registers (BRDR)

BRDRH

Bit:	15	14	13	12	11	10	9	8
	BDA31	BDA30	BDA29	BDA28	BDA27	BDA26	BDA25	BDA24
Initial value:	Undefined	Undefined	Undefined	Undefined	Undefined	Undefined	Undefined	Undefined
R/W:	R	R	R	R	R	R	R	R
Bit:	7	6	5	4	3	2	1	0
	BDA23	BDA22	BDA21	BDA20	BDA19	BDA18	BDA17	BDA16
Initial value:	Undefined	Undefined	Undefined	Undefined	Undefined	Undefined	Undefined	Undefined
R/W:	R	R	R	R	R	R	R	R

BRDRL

Bit:	15	14	13	12	11	10	9	8
	BDA15	BDA14	BDA13	BDA12	BDA11	BDA10	BDA9	BDA8
Initial value:	Undefined	Undefined	Undefined	Undefined	Undefined	Undefined	Undefined	Undefined
R/W:	R	R	R	R	R	R	R	R
Bit:	7	6	5	4	3	2	1	0
	BDA7	BDA6	BDA5	BDA4	BDA3	BDA2	BDA1	BDA0
Initial value:	Undefined	Undefined	Undefined	Undefined	Undefined	Undefined	Undefined	Undefined
R/W:	R	R	R	R	R	R	R	R

The branch destination registers (BRDR) comprise a set of four 32-bit read-only registers. These registers store the branch destination fetch addresses used when performing a PC trace. The BRDR registers form a FIFO (first-in first-out) queue for PC trace use. The queue is shifted at each branch.

The BRDR registers are not initialized by a reset.

6.3 Operation

6.3.1 User Break Operation Sequence

The sequence of operations from setting of break conditions to user break interrupt exception handling is described below.

1. Set the break address in the break address register (BARA/BARB/BARC/BARD), the bits to be masked in the break address mask register (BAMRA/BAMRB/BAMRC/BAMRD), the break bits in the break data register (BDRC/BDRD), and the data to be masked in the break data mask register (BDMRC/BDMRD).

Set the break bus conditions in the break bus cycle register (BBRA/BBRB/BBRC/BBRD). Make three settings—CPU cycle/on-chip DMAC cycle select, instruction fetch/data access select, and read/write select—for each of BBRA, BBRB, BBRC, and BBRD. A user break interrupt will not be generated for a channel for which any one of these settings is 00.

Set the respective conditions in the corresponding BRCR register bits.

2. When a set condition is satisfied, the UBC sends a user break interrupt request to the interrupt controller (INTC). The CPU condition match flag (CMFCA/CMFCB/CMFCC/CMFCD) and DMAC condition match flag (CMFPA/CMFPB/CMFPC/CMFPD) is also set for the matched condition for the respective channel.
3. The INTC determines the priority of the user break interrupt. As the priority level of a user break interrupt is 15, the interrupt is accepted if the level set in the interrupt mask bits (I3 to I0) in the status register (SR) is 14 or less. If the level set in bits I3 to I0 is 15, the user break interrupt is not accepted, but is held pending until it can be. For details of priority determination, see section 5, Interrupt Controller (INTC).
4. If the user break interrupt is accepted after its priority is determined, the CPU begins user break interrupt exception handling.
5. Whether a set condition is matched or not can be ascertained from the respective condition match flag (CMFCA, CMFPA, CMFCB, CMFPB, CMFCC, CMFPC, CMFCD, or CMFPD). These flags are set by a match with the set condition, but are not reset. Therefore, if the setting of a particular flag is to be checked again, the flag must be cleared by writing 0.
When an execution-times break is specified for channel C or D, the CMFCC, CMFPC, CMFCD, or CMFPD flag is set when the number of executions matches the number of executions specified by BETRC or BETRD.

6.3.2 Instruction Fetch Cycle Break

1. If a CPU/instruction fetch/read/word setting is made in the break bus cycle register (BBRA, BBRB, BBRC, or BBRD), a CPU instruction fetch cycle can be selected as a break condition. In this case, it is possible to specify whether the break is to be effected before or after execution of the relevant instruction by means of the PCBA/PCBB/PCBC/PCBD bit in the break control register (BRCR).
2. In the case of an instruction for which pre-execution is set as the break condition, the break is performed when it has been confirmed that the instruction has been fetched and is to be executed. Consequently, a break cannot be set for an overrun-fetched instruction (an instruction fetched but not executed in the event of a branch or interrupt transition). If a break is set for the delay slot of a delayed branch instruction, or for the instruction following an instruction for which interrupts are prohibited, such as LCD, an interrupt is generated before execution of the next instruction at which interrupts are accepted.
3. With the post-execution condition, an interrupt is generated after execution of the instruction set as the break condition, and before execution of the following instruction. As in 2 above, a break cannot be set for an overrun-fetched instruction. If a break is set for a delayed branch instruction, or for an instruction for which interrupts are prohibited, such as LCD, an interrupt is generated before execution of the next instruction at which interrupts are accepted.
4. When an instruction fetch cycle is set for channel C or D, break data register C (BDRC) or break data register D (BDRD) is ignored. Therefore, break data need not be set for an instruction fetch cycle break.
5. When an instruction fetch cycle is set, the start address at which that instruction is located should be set for the break. A break will not occur if a different address is set. Also, a break will not occur if the address of the lower word of a 32-bit instruction is set.

6.3.3 Data Access Cycle Break

1. Memory cycles for which a CPU data access break can be set are memory cycles due to instructions and stack operations and vector reads when exception handling is executed. A CPU data access break cannot be set for a vector fetch cycle of an external vector interrupt, for burst write of a synchronous DRAM, or for a dummy access cycle of a single read.
2. Table 6.2 shows the bits of the break address register and the address bus that are compared for each operand size to determine whether a break condition has been matched.

Table 6.2 Data Access Cycle Address and Operand Size Comparison Conditions

Access Size	Compared Address Bits
Longword	Bits 31 to 2 of break address register compared with bits 31 to 2 of address bus
Word	Bits 31 to 1 of break address register compared with bits 31 to 1 of address bus
Byte	Bits 31 to 0 of break address register compared with bits 31 to 0 of address bus

This means, for example, that if address H'00001003 is set without specifying a size condition, bus cycles that satisfy the break conditions are as follows (assuming that all other conditions are satisfied):

Longword access at address H'00001000

Word access at address H'00001002

Byte access at address H'00001003

3. When data value is included in break condition in channel C
When the data value is included in the break conditions, specify longword, word, or byte as the operand size in break bus cycle register C (BBRC). When the data value is included in the break conditions, a break interrupt is generated on a match of the address condition and the data condition.
When byte data is specified, set the same data in the two bytes comprising bits 15 to 8 and bits 7 to 0 in break data register C (BDRC) and break data mask register C (BDMRC). If word or byte is designated, bits 31 to 16 of BDRC and BDMRC are ignored.
Similar conditions apply when the data value is included in the break conditions for channel D.

6.3.4 Saved Program Counter (PC) Value

1. When instruction fetch (pre-instruction-execution) is set as break condition

The program counter (PC) value saved to the stack in user break interrupt exception handling is the address of the instruction for which the break condition matched. In this case, the fetched instruction is not executed, a user break interrupt being generated prior to its execution. If a setting is made for an instruction following an instruction for which interrupts are prohibited, the break is effected before execution of the next instruction at which interrupts are accepted, so that the saved PC value is the address at which the break occurs.

2. When instruction fetch (post-instruction-execution) is set as break condition

The program counter (PC) value saved to the stack in user break interrupt exception handling is the address of the next instruction to be executed after the instruction for which the break condition matched. In this case, the fetched instruction is executed, and a user break interrupt is generated before execution of the next instruction. However, if a setting is made for an instruction for which interrupts are prohibited, the break is effected before execution of the next instruction at which interrupts are accepted, so that the saved PC value is the address at which the break occurs.

3. When data access (CPU/on-chip DMAC) is set as break condition

The value saved is the start address of the next instruction after the instruction for which execution has been completed when user break exception handling is initiated.

When data access (CPU/on-chip DMAC) is set as a break condition, the point at which the break is to be made cannot be specified. A break is effected before execution of the instruction about to be fetched around the time of the break data access.

6.3.5 X Memory Bus or Y Memory Bus Cycle Break

A break condition for an X bus cycle or Y bus cycle can only be specified for channel C or D. When XYEC in BBRC or XYED in BBRD is set to 1, break addresses and break data on the X memory bus or Y memory bus are selected. Either the X memory bus or the Y memory bus must be selected with the XYSC bit in BBRC or the XYSD bit in BBRD; the X and Y memory buses cannot both be included in the break conditions at the same time. The break conditions are applied to X memory bus cycles or Y memory bus cycles by setting the CPU bus master, data access cycle, read or write access, and word operand size or no operand size specification.

When an X memory address is selected as a break condition, specify the X memory address in the upper 16 bits of BARC and BAMRC or BARD and BAMRD; when a Y memory address is selected, specify the Y memory address in the lower 16 bits of BARC and BAMRC or BARD and BAMRD. The same method is used to specify X memory data or Y memory data for BDRC and BDMRC or BDRD and BMRD.

6.3.6 Sequential Break

Channel C to Channel D: When SEQ1 in BRCR is set to 0 and SEQ0 is set to 1, a sequential break occurs when the conditions are met for channel C and then channel D, in that order. This causes the BRCR condition match flag for each channel to be set to 1.

If the break conditions for channels C and D are met at the same time, and the conditions had not already been met for channel C, the conditions are considered to be met for channel C alone, in the same manner as if the conditions were met for channel C first. Also, if the conditions for channel C have already been met when the break conditions for channels C and D are met at the same time, the conditions for channel D are considered to be met and a break occurs.

Channel B to Channel C to Channel D: When SEQ1 in BRCR is set to 1 and SEQ0 is set to 0, a sequential break occurs when the conditions are met for channel B, channel C, and then channel D, in that order. This causes the BRCR condition match flag for each channel to be set to 1.

If the break conditions for channels B and C are met at the same time, and the conditions had not already been met for channel B, the conditions are considered to be met for channel B. Also, if the conditions for channel B have already been met when the break conditions for channels B and C are met at the same time, the conditions for channel C are considered to be met.

If the break conditions for channels C and D are met at the same time, and the conditions had not already been met for channel C, the conditions are considered to be met for channel C. Also, if the conditions for channel C have already been met when the break conditions for channels C and D are met at the same time, the conditions for channel D are considered to be met and a break occurs.

Channel A to Channel B to Channel C to Channel D: When SEQ1 in BRCR is set to 1 and SEQ0 is set to 1, a sequential break occurs when the conditions are met for channel A, channel B, channel C, and then channel D, in that order. This causes the BRCR condition match flag for each channel to be set to 1.

If the break conditions for channels A and B are met at the same time, and the conditions had not already been met for channel A, the conditions are considered to be met for channel A. Also, if the conditions for channel A have already been met when the break conditions for channels A and B are met at the same time, the conditions for channel B are considered to be met.

If the break conditions for channels B and C are met at the same time, and the conditions had not already been met for channel B, the conditions are considered to be met for channel B. Also, if the conditions for channel B have already been met when the break conditions for channels B and C are met at the same time, the conditions for channel C are considered to be met.

If the break conditions for channels C and D are met at the same time, and the conditions had not already been met for channel C, the conditions are considered to be met for channel C. Also, if the conditions for channel C have already been met when the break conditions for channels C and D

are met at the same time, the conditions for channel D are considered to be met and a break occurs.

However, if bus cycle conditions match for two of the channels included in the sequential conditions, and if the bus cycle conditions (which is the first break condition for the adjacent channel) have been specified as pre-execution break (PCB bit of BRCR set to 0) and (using the break bus cycle register) instruction fetch, a break occurs and the BRCR condition match flag is set to 1.

Bus X or bus Y may be selected in the sequential break setting, and it is also possible to set the number of executions as a brake condition. For example, if an execution-times break is set for channels C and D, a user break interrupt will be issued if, after the execution-times set for channel set in BETRC has occurred, the execution-times condition set in BETRD for channel D is met.

6.3.7 PC Traces

1. A PC trace is started by setting the PC trace enable bit (PCTE) to 1 in BRCR. When a branch (branch instruction, repeat, or interrupt) occurs the address that enables the branch source address to be calculated and the branch destination address are stored in the branch source register (BRSR) and branch destination register (BRDR). The address stored in BRDR is the branch destination instruction fetch address. The address stored in BRSR is the last instruction fetch address prior to the branch. A pointer indicating the relationship to the instruction executed immediately before the branch is stored in the branch flag register (BRFR).
2. The address of the instruction executed immediately before the branch occurred can be calculated from the address stored in BRSR and the pointer stored in BRFR. Designating the address stored in BRSR as BSA, the pointer stored in BRFR as PID, and the address prior to the branch as IA, then IA is found from the following equation:

$$IA = BSA - 2 \times PID$$

Caution is necessary if an interrupt (branch) occurs before the instruction at the branch destination is executed. In the case illustrated in figure 6.2., the address of instruction “Exec”, executed immediately before the branch, is calculated from the equation $IA = BSA - 2 \times PID$. However, if branch “branch” is a delayed branch instruction with a delay slot and the branch destination is a $4n+2$ address, branch destination address “Dest” specified by the branch instruction is stored directly in BRSR. In this case, therefore, equation $IA = BSA - 2 \times PID$ is not applied, and PID is invalid. BSA is at a $4n+2$ boundary in this case only, categorized as shown in table 6.3.

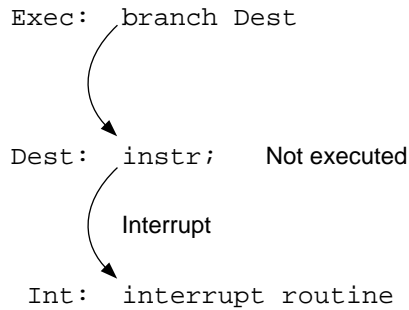

Figure 6.2 When Interrupt Occurs before Branch Instruction Is Executed

Table 6.3 BSA Values Stored in Exception Handling before Execution of Branch Destination Instruction

Branch	Branch Destination (Dest)	BSA	Branch Source Address Calculable by Means of BRSR and BRFR
Delay	4n	4n	Exec = IA = BSA - 2 × PID
	4n + 2	4n + 2	Dest = BSA
No delay	4n or 4n + 2	4n	Exec = IA = BSA - 2 × PID

If PID is an odd number, the value incremented by 2 indicates the instruction buffer, but the equations in the table do not take this into account. Therefore, the calculation can be performed using the values of BSA stored in BRSR and PID stored in BRFR.

3. The location indicated by the address before branch occurrence, IA, differs according to the kind of branch.
 - a. Branch instruction: Branch instruction address
 - b. Repeat loop: 2nd instruction from last in repeat loop

```

Repeat_Start: inst (1); → BRDR
              inst(2);
              :
              inst (n-1); → Address calculated from BRSR and BRFR
Repeat End:  inst (n);
  
```

- c. Interrupt: Instruction executed immediately before interrupt

The address of the first instruction in the interrupt routine is stored in BRDR.

In a repeat loop consisting of no more than three instructions, an instruction fetch cycle is not generated. As the branch destination address is unknown, a PC trace cannot be performed.

4. BRSR, BRDR, and BRFR have a four-queue structure. When the stored address is read in a PC trace, the read is performed from the head of the queue. Reads should be performed in the order BRFR, BRSR, BRDR. After BRDR is read, the queue shifts by one. Use longword access to read BRSR and BRDR.

6.3.8 Examples of Use

CPU Instruction Fetch Cycle Break Condition Settings

A. Register settings: BARA = H'00000404 / BAMRA = H'00000000 / BBRA = H'0054
BARB = H'00003080 / BAMRB = H'0000007F / BBRB = H'0054
BARC = H'00008010 / BAMRC = H'00000006 / BBRC = H'0054
BDRC = H'00000000 / BDMRC = H'00000000
BARD = H'0000FF04 / BAMRD = H'00000000 / BBRD = H'0054
BDRD = H'00000000 / BDMRD = H'00000000
BRCR = H'04000400

Set conditions: All channels independent

Channel A: Address: H'00000404; address mask: H'00000000
Bus cycle: CPU, instruction fetch (post-execution),
read (operand size not included in conditions)

Channel B: Address: H'00003080; address mask: H'0000007F
Bus cycle: CPU, instruction fetch (pre-execution),
read (operand size not included in conditions)

Channel C: Address: H'00008010; address mask: H'00000006
Data: H'00000000; data mask: H'00000000
Bus cycle: CPU, instruction fetch (post-execution),
read (operand size not included in conditions)

Channel D: Address: H'0000FF04; address mask: H'00000000
Data: H'00000000; data mask: H'00000000
Bus cycle: CPU, instruction fetch (pre-execution),
read (operand size not included in conditions)

A user break interrupt is generated after execution of the instruction at address H'00000404, before execution of instructions at addresses H'00003080 to H'000030FF, after execution of instructions at addresses H'00008010 to H'00008016, or before execution of the instruction at address H'0000FF04.

B. Register settings: BARA = H'00027128 / BAMRA = H'00000000 / BBRA = H'005A
BARB = H'00031415 / BAMRB = H'00000000 / BBRB = H'0054
BARC = H'00037226 / BAMRC = H'00000000 / BBRC = H'0056

BDRC = H'00000000 / BDMRC = H'00000000
BARD = H'0003722E / BAMRD = H'00000000 / BBRD = H'0056
BDRD = H'00000000 / BDMRD = H'00000000
BRRC = H'00080000

Set conditions: Channels A and B independent, channel C → channel D sequential mode

Channel A: Address: H'00027128; address mask: H'00000000
Bus cycle: CPU, instruction fetch (pre-execution), write, word

Channel B: Address: H'00031415; address mask: H'00000000
Bus cycle: CPU, instruction fetch (pre-execution),
read (operand size not included in conditions)

Channel C: Address: H'00037226; address mask: H'00000000
Data: H'00000000; data mask: H'00000000
Bus cycle: CPU, instruction fetch (pre-execution), read, word

Channel D: Address: H'0003722E; address mask: H'00000000
Data: H'00000000; data mask: H'00000000
Bus cycle: CPU, instruction fetch (pre-execution), read, word

On channel A, a user break interrupt is not generated as an instruction fetch is not a write cycle.

On channel B, a user break interrupt is not generated as an instruction fetch is performed on an even address.

A user break interrupt is generated by a channel C and D sequential condition match before execution of the instruction at address H'0003722E following execution of the instruction at address H'00037226.

C. Register settings: BBRA = H'0000
BBRB = H'0000
BARC = H'00037226 / BAMRC = H'00000000 / BBRD = H'005A
BDRC = H'00000000 / BDMRC = H'00000000
BARD = H'0003722E / BAMRD = H'00000000 / BBRD = H'0056
BDRD = H'00000000 / BDMRD = H'00000000
BRRC = H'00080000

Set conditions: Channels A and B independent, channel C → channel D sequential mode

Channel A: Not used

Channel B: Not used

Channel C: Address: H'00037226; address mask: H'00000000
Data: H'00000000; data mask: H'00000000
Bus cycle: CPU, instruction fetch (pre-execution), write, word

Channel D: Address: H'0003722E; address mask: H'00000000
Data: H'00000000; data mask: H'00000000
Bus cycle: CPU, instruction fetch (pre-execution), read, word

As the channel C break condition is a write cycle, the condition is not matched, and as the sequential conditions are not satisfied, a user break interrupt is not generated.

D. Register settings: BBRA = H'0000
BARB = H'00000500 / BAMRB = H'00000000 / BBRB = H'0057
BARC = H'00000A00 / BAMRC = H'00000000 / BBRC = H'0057
BDRC = H'00000000 / BDMRC = H'00000000
BARD = H'00001000 / BAMRD = H'00000000 / BBRD = H'0057
BDRD = H'00000000 / BDMRD = H'00000000
BRRCR = H'00102020 / BETRC = H'0005 / BETRD = H'000A

Channel A: Not used

Channel B: Address: H'00000500; address mask: H'00000000
Data: H'00000000; data mask: H'00000000
Bus cycle: CPU, instruction fetch (pre-execution), read, word

Channel C: Address: H'00000A00; address mask: H'00000000
Data: H'00000000; data mask: H'00000000
Bus cycle: CPU, instruction fetch (pre-execution), read, word
Execution-times break enabled (5 times)

Channel D: Address: H'00001000; address mask: H'00000000
Data: H'00000000; data mask: H'00000000
Bus cycle: CPU, instruction fetch (pre-execution), read, word
Execution-times break enabled (10 times)

After the instruction at address H'0000500 is executed, and the instruction at address H'00000A00 is executed five times, a user break interrupt is generated after the instruction at address H'00001000 has been executed nine times, but before it is executed a tenth time.

CPU Data Access Cycle Break Condition Settings

Register settings: BARA = H'00123456 / BAMRA = H'00000000 / BBRA = H'0064
BARB = H'01000000 / BAMRB = H'00000000 / BBRB = H'0066
BARC = H'000ABCDE / BAMRC = H'000000FF / BBRC = H'006A
BDRC = H'0000A512 / BDMRC = H'00000000
BARD = H'1001E000 / BAMRD = H'FFFF0000 / BBRD = H'036A
BDRD = H'00004567 / BDMRD = H'00000000
BRDR = H'00000808

Set conditions: All channels independent

Channel A: Address: H'00123456; address mask: H'00000000
Bus cycle: CPU, data access, read (operand size not included
in conditions)

Channel B: Address: H'01000000; address mask: H'00000000
Bus cycle: CPU, data access, read, word

Channel C: Address: H'000ABCDE; address mask: H'00000000
Data: H'0000A512; data mask: H'00000000
Bus cycle: CPU, data access, write, word

Channel D: Y address: H'1001E000; address mask: H'FFFF0000
Data: H'00004567; data mask: H'00000000
Bus cycle: CPU, data access, write, word

On channel A, a user break interrupt is generated by a longword read at address H'00123456, a word read at address H'00123456, or a byte read at address H'00123456.

On channel B, a user break interrupt is generated by a word read at address H'01000000.

On channel C, a user break interrupt is generated when H'A512 is written by word access to an address from H'000ABC00 to H'000ABCFE.

On channel D, a user break interrupt is generated when H'4567 is written by word access to address H'1001E000 in Y memory space.

DMA Data Access Cycle Break Condition Settings

Register settings: BARA = H'00314156 / BAMRA = H'00000000 / BBRA = H'0094
BBRB = H'0000
BBRC = H'0000
BARD = H'00055555 / BAMRD = H'00000000 / BBRD = H'00A9
BDRD = H'00007878 / BDMRD = H'00000F0F
BRRCR = H'00000008

Set conditions: All channels independent

Channel A: Address: H'00314156; address mask: H'00000000
Bus cycle: DMAC, instruction fetch, read (operand not included in conditions)

Channel B: Not used

Channel C: Not used

Channel D: Address: H'00055555; address mask: H'00000000
Data: H'00007878; data mask: H'00000F0F
Bus cycle: DMAC, data access, write, byte

On channel A, a user break interrupt is not generated as an instruction fetch is not performed in a DMAC cycle.

On channel D, a user break interrupt is generated when the DMAC writes H'7* (*: Don't care) is written by byte access to address H'00055555.

6.3.9 Usage Notes

1. UBC registers can be read and written to only by the CPU.
2. Note the following concerning sequential break specifications:
 - a. As the CPU has a pipeline structure, the order of instruction fetch cycles and memory cycles is determined by the pipeline. Therefore, a break will occur if channel condition matches in the bus cycle order satisfy the sequential condition.
 - b. If, of the channels included in a sequential condition, the channel bus cycle conditions constituting the first break conditions of adjacent channels are specified as a pre-execution break (PCB bit cleared to 0 in BRRCR) and an instruction fetch (designated by the break bus cycle register), note that when the bus cycle conditions for the two channels are matched simultaneously, a break is effected and the BRRCR condition match flags are set to 1.
3. When changing a register setting, the written value normally becomes effective in three cycles. In an on-chip memory fetch, two instructions are fetched simultaneously. If the fetch of the second instruction has been set as a break condition, even if the break condition is changed by modifying the relevant UBC registers immediately after the fetch of the first instruction, a user break interrupt will still be generated prior to the second instruction. To fix a timing at which the setting is definitely changed, the last register value written should be read with a dummy access. The changed setting will be valid from this point on.
4. If a user break interrupt is generated by an instruction fetch condition match, and the condition is matched again in the UBC during execution of the exception service routine, exception handling for that break will be executed when the interrupt request mask value in SR becomes 14 or below. Therefore, when masking addresses and setting an instruction fetch/post-execution condition to perform step-execution, ensure that an address match does not occur during execution of the UBC's exception service routine.
5. Note the following when specifying an instruction in a repeat loop that includes a repeat instruction as a break condition.

When an instruction in a repeat loop is specified as a break condition:

- a. A break will not occur during execution of a repeat loop comprising no more than three instructions.
 - b. When an execution-times break is set, an instruction fetch from memory will not occur during execution of a repeat loop comprising no more than three instructions. Consequently, the value in the break execution times register (BETRC or BETRD) will not be decremented.
6. Do not execute a branch instruction immediately after reading a PC trace register (BRFR, BRSR, or BRDR).

7. If CPU and DMAC bus cycles are set as break conditions when an execution-times break has been set, BETR will only be decremented once even if CPU and DMAC condition matches occur simultaneously.
8. UBC and H-UDI are used by the emulator. For this reason, the operation of UBC and H-UDI may differ in some cases between the emulator and the actual device. If UBC and H-UDI are not used on the user's system, no register setting should be performed.

Section 7 Bus State Controller (BSC)

7.1 Overview

The bus state controller (BSC) manages the address spaces and outputs control signals to allow optimum memory accesses to the five spaces. This enables memories like DRAM, and SDRAM, and peripheral chips, to be linked directly.

7.1.1 Features

The BSC has the following features:

- Address space is managed as five spaces
 - Maximum linear 32 Mbytes for each of the address spaces CS0 to CS4
 - Memory type (DRAM, synchronous DRAM, burst ROM, etc.) can be specified for each space.
 - Bus width (8, 16, or 32 bits) can be selected for each space.
 - Wait state insertion can be controlled for each space.
 - Control signals are output for each space.
- Cache
 - Cache area and cache-through area can be selected by access address.
 - In cache access, in the event of a cache access miss 16 bytes are read consecutively in 4-byte units to fill the cache. Write-through mode/write-back mode can be selected for writes.
 - In cache-through access, access is performed according to access size.
- Refresh
 - Supports $\overline{\text{CAS}}$ -before- $\overline{\text{RAS}}$ refresh (auto-refresh) and self-refresh.
 - Refresh interval can be set by the refresh counter and clock selection.
 - Intensive refreshing by means of refresh count setting (1, 2, 4, 6, or 8)
- Direct interface to DRAM
 - Row/column address multiplex output.
 - Burst transfer during reads, fast page mode for consecutive accesses.
 - TP cycle generation to secure $\overline{\text{RAS}}$ precharge time.
 - EDO mode
- Direct interface to synchronous DRAM
 - Row/column address multiplex output.
 - Selection of burst read, single write mode or burst read, burst write mode
 - Bank active mode

- Bus arbitration
 - All resources are shared with the CPU, and use of the bus is granted on reception of a bus release request from off-chip.
- Refresh counter can be used as an interval timer
 - Interrupt request generation on compare match (CMI interrupt request signal).

7.1.2 Block Diagram

Figure 7.1 shows a block diagram of the BSC.

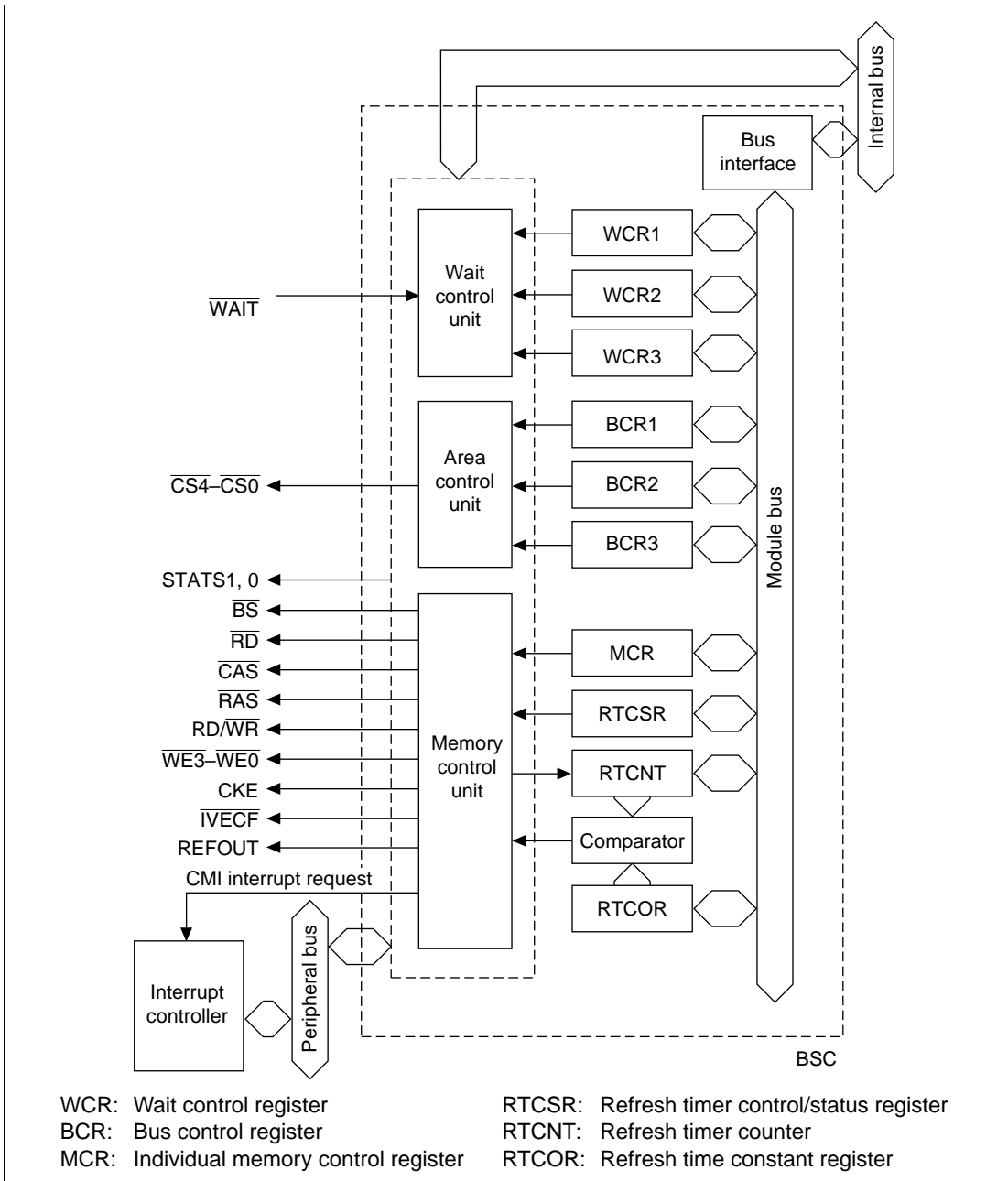

Figure 7.1 BSC Block Diagram

7.1.3 Pin Configuration

Table 7.1 shows the BSC pin configuration.

Table 7.1 Pin Configuration

Signal	I/O	With Bus Released	Description
A24–A0	O	Hi-Z	Address bus. 32 Mbytes of memory space can be specified with 25 bits
D31–D0	I/O	Hi-Z	32-bit data bus. When reading or writing a 16-bit width area, use D15–D0; when reading or writing a 8-bit width area, use D7–D0. With 8-bit accesses that read or write a 32-bit width area, input and output the data via the byte position determined by the lower address bits of the 32-bit bus
\overline{BS}	O	Hi-Z	Indicates start of bus cycle or monitor. With the basic interface (device interfaces except for DRAM, synchronous DRAM), signal is asserted for a single clock cycle simultaneous with address output. The start of the bus cycle can be determined by this signal
$\overline{CS0}$ – $\overline{CS4}$	O	Hi-Z	Chip select. $\overline{CS3}$ is not asserted when the CS3 space is DRAM space
$\overline{RD}/\overline{WR}$	O	Hi-Z	Read/write signal. Signal that indicates access cycle direction (read/write). Connected to \overline{WE} pin when DRAM/synchronous DRAM is connected
\overline{RAS}	O	Hi-Z	\overline{RAS} pin for DRAM/synchronous DRAM
$\overline{CAS}/\overline{OE}$	O	Hi-Z	Open when using DRAM Connected to \overline{OE} pin when using EDO RAM Connected to \overline{CAS} pin when using synchronous DRAM
\overline{RD}	O	Hi-Z	Read pulse signal (read data output enable signal). Normally, connected to the device's \overline{OE} pin; when there is an external data buffer, the read cycle data can only be output when this signal is low
\overline{WAIT}	I	Don't care	Hardware wait input
\overline{BRLS}	I	I	Bus release request input
\overline{BGR}	O	O	Bus grant output
CKE	O	O	Synchronous DRAM clock enable control. Signal for supporting synchronous DRAM self-refresh
\overline{IVECF}	O	O	Interrupt vector fetch
DREQ0	I	I	DMA request 0
DACK0	O	O	DMA acknowledge 0

Table 7.1 Pin Configuration (cont)

Signal	I/O	With Bus Released	Description
DREQ1	I	I	DMA request 1
DACK1	O	O	DMA acknowledge 1
REFOUT	O	O	Refresh execution request output when bus is released
DQMUU/ $\overline{WE3}$	O	Hi-Z	When synchronous DRAM is used, connected to DQM pin for the most significant byte (D31–D24). For ordinary space, indicates writing to the most significant byte
DQMUL/ $\overline{WE2}$	O	Hi-Z	When synchronous DRAM is used, connected to DQM pin for the second byte (D23–D16). For ordinary space, indicates writing to the second byte
DQMLU/ $\overline{WE1}$	O	Hi-Z	When synchronous DRAM is used, connected to DQM pin for the third byte (D15–D8). For ordinary space, indicates writing to the third byte
DQMLL/ $\overline{WE0}$	O	Hi-Z	When synchronous DRAM is used, connected to DQM pin for the least significant byte (D7–D0). For ordinary space, indicates writing to the least significant byte
$\overline{CAS3}$	O	Hi-Z	When DRAM is used, connected to \overline{CAS} pin for the most significant byte (D31–D24)
$\overline{CAS2}$	O	Hi-Z	When DRAM is used, connected to \overline{CAS} pin for the second byte (D23–D16)
$\overline{CAS1}$	O	Hi-Z	When DRAM is used, connected to \overline{CAS} pin for the third byte (D15–D8)
$\overline{CAS0}$	O	Hi-Z	When DRAM is used, connected to \overline{CAS} pin for the least significant byte (D7–D0)
STATS0, 1	O	O	Bus master identification 00: CPU 01: DMAC 10: E-DMAC 11: Other
BUSHIZ	I	I	Signal used in combination with \overline{WAIT} signal to place bus and strobe signals in the high-impedance state without the ending bus cycle.

Note: Hi-Z: High impedance

7.1.4 Register Configuration

The BSC has ten registers. These registers are used to control wait states, bus width, interfaces with memories like DRAM, synchronous DRAM, and burst ROM, and DRAM and synchronous DRAM refreshing. The register configurations are shown in table 7.2.

The size of the registers themselves is 16 bits. If read as 32 bits, the upper 16 bits are 0. *In order to prevent writing mistakes, 32-bit writes are accepted only when the value of the upper 16 bits of the write data is H'A55A; no other writes are performed.* Initialize the reserved bits.

Initialization Procedure: Do not access a space other than CS0 until the settings for the interface to memory are completed.

Table 7.2 Register Configuration

Name	Abbr.	R/W	Initial Value	Address* ¹	Access Size
Bus control register 1	BCR1	R/W	H'03F0	H'FFFFFFE0	16* ² , 32
Bus control register 2	BCR2	R/W	H'00FC	H'FFFFFFE4	16* ² , 32
Bus control register 3	BCR3	R/W	H'0F00	H'FFFFFFFC	16* ² , 32
Wait control register 1	WCR1	R/W	H'AAFF	H'FFFFFFE8	16* ² , 32
Wait control register 2	WCR2	R/W	H'000B	H'FFFFFFC0	16* ² , 32
Wait control register 3	WCR3	R/W	H'0000	H'FFFFFFC4	16* ² , 32
Individual memory control register	MCR	R/W	H'0000	H'FFFFFFEC	16* ² , 32
Refresh timer control/status register	RTCSR	R/W	H'0000	H'FFFFFFF0	16* ² , 32
Refresh timer counter	RTCNT	R/W	H'0000	H'FFFFFFF4	16* ² , 32
Refresh time constant register	RTCOR	R/W	H'0000	H'FFFFFFF8	16* ² , 32

Notes: *1 This address is for 32-bit accesses; for 16-bit accesses add 2.

*2 16-bit access is for read only.

7.1.5 Address Map

The address map, which has a memory space of 320 Mbytes, is divided into five spaces. The types and data width of devices that can be connected are specified for each space. The overall space address map is shown in table 7.3. Since the spaces of the cache area and the cache-through area are actually the same, and the maximum memory space that can be connected is 160 Mbytes. This means that when address H'20000000 is accessed in a program, the data accessed is actually in H'00000000.

The chip has 16-kbyte RAM as on-chip memory. The on-chip RAM is divided into an X area and a Y area, which can be accessed in parallel with the DSP instruction. See the *SH-1/SH-2/SH-DSP Programming Manual* for more information.

There are several spaces for cache control. These include the associative purge space for cache purges, address array read/write space for reading and writing addresses (address tags), and data array read/write space for forced reads and writes of data arrays.

Table 7.3 Address Map

Address	Space	Memory	Size
H'00000000–H'01FFFFFF	CS0 space, cache area	Ordinary space or burst ROM	32 Mbytes
H'02000000–H'03FFFFFF	CS1 space, cache area	Ordinary space	32 Mbytes
H'04000000–H'05FFFFFF	CS2 space, cache area	Ordinary space or synchronous DRAM* ²	32 Mbytes
H'06000000–H'07FFFFFF	CS3 space, cache area	Ordinary space, synchronous DRAM* ² , or DRAM	32 Mbytes
H'08000000–H'09FFFFFF	CS4 space, cache area	Ordinary space (I/O device)	32 Mbytes
H'0A000000–H'0FFFFFFF	Reserved* ¹		
H'10000000–H'1000DFFF	Reserved* ¹		
H'1000E000–H'1000EFFF	On-chip X RAM area		8 kbytes
H'1000F000–H'1001DFFF	Reserved* ¹		
H'1001E000–H'1001EFFF	On-chip Y RAM area		8 kbytes
H'1001F000–H'1FFFFFFF	Reserved* ¹		
H'20000000–H'21FFFFFF	CS0 space, cache-through area	Ordinary space or burst ROM	32 Mbytes
H'22000000–H'23FFFFFF	CS1 space, cache-through area	Ordinary space	32 Mbytes

Table 7.3 Address Map (cont)

Address	Space	Memory	Size
H'24000000–H'25FFFFFF	CS2 space, cache-through area	Ordinary space or synchronous DRAM* ²	32 Mbytes
H'26000000–H'27FFFFFF	CS3 space, cache-through area	Ordinary space, synchronous DRAM* ² , or DRAM	32 Mbytes
H'28000000–H'29FFFFFF	CS4 space, cache-through area	Ordinary space (I/O device)	32 Mbytes
H'2A000000–H'3FFFFFFF	Reserved* ¹		
H'40000000–H'49FFFFFF	Associative purge space		160 Mbytes
H'4A000000–H'5FFFFFFF	Reserved* ¹		
H'60000000–H'7FFFFFFF	Address array, read/write space		512 Mbytes
H'80000000–H'BFFFFFFF	Reserved* ¹		
H'C0000000–H'C0000FFF	Data array, read/write space		4 kbytes
H'C0001000–H'DFFFFFFF	Reserved* ¹		
H'E0000000–H'FFFFFFF	Reserved* ¹		
H'FFFF0000–H'FFFF0FFF	For setting synchronous DRAM mode		4 kbytes
H'FFFF1000–H'FFFF7FFF	Reserved* ¹		
H'FFFF8000–H'FFFF8FFF	For setting synchronous DRAM mode		4 kbytes
H'FFFFC000–H'FFFFBFFF	Reserved* ¹		
H'FFFFFFC00–H'FFFFFFF	On-chip peripheral modules		

Notes: *1 Do not access reserved spaces, as operation cannot be guaranteed.

*2 Bank-active mode is not supported for CS2 space synchronous DRAM access; auto-precharge mode is always used.

Bank-active mode is supported for CS3 space synchronous DRAM access.

7.2 Register Descriptions

7.2.1 Bus Control Register 1 (BCR1)

Bit:	15	14	13	12	11	10	9	8
	—	A4LW1	A4LW0	A2EN DIAN	BST ROM	—	AHLW1	AHLW0
Initial value:	0	0	0	0	0	0	1	1
R/W:	R	R/W	R/W	R/W	R/W	R	R/W	R/W
Bit:	7	6	5	4	3	2	1	0
	A1LW1	A1LW0	A0LW1	A0LW0	A4EN DIAN	DRAM2	DRAM1	DRAM0
Initial value:	1	1	1	1	0	0	0	0
R/W:	R/W	R/W	R/W	R/W	R/W	R/W	R/W	R/W

Initialize the ENDIAN, BSTROM, PSHR, and DRAM2–DRAM0 bits after a power-on reset, and do not change their values thereafter. To change other bits by writing to them, write the same value as they are initialized to. Do not access any space other than CS0 until the register initialization ends.

Bit 15—Reserved: This bit is always read as 0. The write value should always be 0.

Bits 14 and 13—Long Wait Specification for Area 4 (A4LW1, A4LW0): From 3 to 14 wait cycles are inserted in CS4 space accesses when the wait control bits (W41, W40) in wait control register 2 (WCR2) are set as long wait (i.e., are set to 11) (see table 7.4).

Bit 12—Endian Specification for Area 2 (A2ENDIAN): In big-endian format, the MSB of byte data is the lowest byte address and byte data goes in order toward the LSB. For little-endian format, the LSB of byte data is the lowest byte address and byte data goes in order toward the MSB. When this bit is 1, the data is rearranged into little-endian format before transfer when the CS2 space is read or written to. It is used when handling data with little-endian processors or running programs written with conscious use of little-endian format.

Bit 12: A2ENDIAN	Description
0	Big-endian (Initial value)
1	Little-endian

Bit 11: BSTROM	Description	
0	Area 0 is accessed normally	(Initial value)
1	Area 0 is accessed as burst ROM	

Bit 10—Reserved: This bit is always read as 0. The write value should always be 0.

Bits 9 and 8—Long Wait Specification for Areas 2 and 3 (AHLW1, AHLW0): When the basic memory interface setting is made for CS2 and CS3, from 3 to 14 wait cycles are inserted in CS2 or CS3 accesses when the bits specifying the respective area waits in the wait control bits (W21, W20 or W31, W30) in wait control register 1 (WCR1) are set as long waits (i.e., are set to 11) (see table 7.4).

Bits 7 and 6—Long Wait Specification for Area 1 (A1LW1, A1LW0): From 3 to 14 wait cycles are inserted in area 1 accesses when the wait control bits (W11, W10) in wait control register 1 (WCR1) are set as long wait (i.e., are set to 11) (see table 7.4).

Bits 5 and 4—Long Wait Specification for Area 0 (A0LW1, A0LW0): When the basic memory interface setting is made for CS0, from 3 to 14 wait cycles are inserted in CS0 accesses when the wait control bits (W01, W00) in wait control register 1 (WCR1) are set as long wait (i.e., are set to 11) (see table 7.4).

Bit 3—Endian Specification for Area 4 (A4ENDIAN): In big-endian mode, the most significant byte (MSB) is the lowest byte address, and byte data is aligned in order toward the least significant byte (LSB). In little-endian mode, the LSB is the lowest byte address, and byte data is aligned in order toward the MSB. When this bit is set to 1, data in read/write accesses to the CS4 space is rearranged into little endian order before being transferred. This is used for data exchange with a little-endian processor or when executing a program written with awareness of little-endian mode.

Bit 3: A4ENDIAN	Description	
0	Big endian	(Initial value)
1	Little endian	

Bits 2 to 0—Enable for DRAM and Other Memory (DRAM2–DRAM0)

DRAM2	DRAM1	DRAM0	Description
0	0	0	CS2 and CS3 are ordinary spaces (Initial value)
		1	CS2 is ordinary space; CS3 is synchronous DRAM space
	1	0	CS2 is ordinary space; CS3 is DRAM space
		1	Reserved (do not set)
1	0	0	CS2 is synchronous DRAM space, CS3 is ordinary space
		1	CS2 and CS3 are synchronous DRAM spaces
	1	0	Reserved (do not set)
		1	Reserved (do not set)

Table 7.4 Wait Values Corresponding to BCR1 and BCR3 Register Settings (All Spaces)

BCR3	BCR1		Wait Value
	AnLW2	AnLW0	
0	0	0	3 cycles inserted
		1	4 cycles inserted
	1	0	5 cycles inserted
		1	6 cycles inserted
1	0	0	8 cycles inserted
		1	10 cycles inserted
	1	0	12 cycles inserted
		1	14 cycles inserted (Initial value)

Note: n = 0 to 4

AHLW2, AHLW1, and AHLW0 are common to CS2 and CS3.

7.2.2 Bus Control Register 2 (BCR2)

Bit:	15	14	13	12	11	10	9	8
	—	—	—	—	—	—	A4SZ1	A4SZ0
Initial value:	0	0	0	0	0	0	0	0
R/W:	R	R	R	R	R	R	R/W	R/W
Bit:	7	6	5	4	3	2	1	0
	A3SZ1	A3SZ0	A2SZ1	A2SZ0	A1SZ1	A1SZ0	—	—
Initial value:	1	1	1	1	1	1	0	0
R/W:	R/W	R/W	R/W	R/W	R/W	R/W	R	R

Initialize BCR2 after a power-on reset and do not write to it thereafter. When writing to it, write the same values as those the bits are initialized to. Do not access any space other than CS0 until the register initialization ends.

The CS0 space bus size specification is set with pins MD4 and MD3. See section 3.3, CS0 Space Bus Width of the CS0 Area, for details.

Bits 15 to 10—Reserved: These bits are always read as 0. The write value should always be 0.

Bits 9 and 8—Bus Size Specification for Area 4 (CS4) (A4SZ1, A4SZ0)

Bit 9: A4SZ1	Bit 8: A4SZ0	Description
0	0	Longword (32-bit) size (Initial value)
	1	Byte (8-bit) size
1	0	Word (16-bit) size
	1	Longword (32-bit) size

Bits 7 and 6—Bus Size Specification for Area 3 (CS3) (A3SZ1, A3SZ0). Effective only when ordinary space is set.

Bit 7: A3SZ1	Bit 6: A3SZ0	Description
0	0	Reserved (do not set)
	1	Byte (8-bit) size
1	0	Word (16-bit) size
	1	Longword (32-bit) size (Initial value)

Bits 5 and 4—Bus Size Specification for Area 2 (CS2) (A2SZ1, A2SZ0): Effective only when ordinary space is set.

Bit 5: A2SZ1	Bit 4: A2SZ0	Description
0	0	Reserved (do not set)
	1	Byte (8-bit) size
1	0	Word (16-bit) size
	1	Longword (32-bit) size (Initial value)

Bits 3 and 2—Bus Size Specification for Area 1 (CS1) (A1SZ1, A1SZ0)

Bit 3: A1SZ1	Bit 2: A1SZ0	Description
0	0	Reserved (do not set)
	1	Byte (8-bit) size
1	0	Word (16-bit) size
	1	Longword (32-bit) size (Initial value)

Bits 1 and 0—Reserved: These bits are always read as 0. The write value should always be 0.

7.2.3 Bus Control Register 3 (BCR3)

Bit:	15	14	13	12	11	10	9	8
	—	—	—	—	A4LW2	AHLW2	A1LW2	A0LW2
Initial value:	0	0	0	0	1	1	1	1
R/W:	R	R	R	R	R/W	R/W	R/W	R/W
Bit:	7	6	5	4	3	2	1	0
	DSWW1	DSWW0	—	—	—	BASEL	EDO	BWE
Initial value:	0	0	0	0	0	0	0	0
R/W:	R/W	R/W	R	R	R	R/W	R/W	R/W

Initialize the BASEL, EDO, and BWE bits after a power-on reset and do not write to them thereafter. To change other bits by writing to them, write the same value as they are initialized to. Do not access any space other than CS0 until the register initialization ends.

Bits 15 to 12—Reserved bits: These bits are always read as 0. The write value should always be 0.

Bits 11 to 8—Long Wait Specification for Areas 0 to 4 (AnLW2): When the basic memory interface setting is made for CS n, from 3 to 14 wait cycles are inserted in CS n accesses,

according to the combination with the long wait specification bits (AnLW1 and AnLW0) in BCR1, when the bits specifying the wait in the wait control register are set as long wait (i.e., are set to 11). For a basic description of long waits, see section 7.2.1, Bus Control Register 1 (BCR1).

Bits 7 and 6—DMA Single-Write Wait (DSWW1, DSWW0): These bits determine the number of wait states inserted between DACK assertion and CASn assertion when writing to DRAM or EDO RAM in DMA single address mode.

Bit 7: DSWW1	Bit 6: DSWW0	Description
0	0	0 waits (Initial value)
	1	1 wait
1	0	2 waits
	1	Reserved (do not set)

Bits 5 to 3—Reserved bits: These bits are always read as 0. The write value should always be 0.

Bit 2—Number of Banks Specification when Using 64M Synchronous DRAM (BASEL): When 64M synchronous DRAM is specified by AMX2–AMX0 in MCR, the number of banks can be specified.

Bit 2: BASEL	Description
0	4 banks (Initial value)
1	2 banks

Bit 1—EDO Mode Specification (EDO): Enables EDO mode to be specified when DRAM is specified for CS3 space.

Bit 1: EDO	Description
0	High-speed page mode (Initial value)
1	EDO mode

Bit 0—Synchronous DRAM Burst Write Specification (BWE): Enables burst write mode to be specified when synchronous DRAM is specified for CS2 or CS3 space.

Bit 0: BWE	Description
0	Single write mode (Initial value)
1	Burst write mode

7.2.4 Wait Control Register 1 (WCR1)

Bit:	15	14	13	12	11	10	9	8
	IW31	IW30	IW21	IW20	IW11	IW10	IW01	IW00
Initial value:	1	0	1	0	1	0	1	0
R/W:	R/W	R/W	R/W	R/W	R/W	R/W	R/W	R/W
Bit:	7	6	5	4	3	2	1	0
	W31	W30	W21	W20	W11	W10	W01	W00
Initial value:	1	1	1	1	1	1	1	1
R/W:	R/W	R/W	R/W	R/W	R/W	R/W	R/W	R/W

Do not access a space other than CS0 until the settings for register initialization are completed.

Bits 15 to 8—Idles between Cycles for Areas 3 to 0 (IW31–IW00): These bits specify idle cycles inserted between consecutive accesses to different CS spaces. Idles are used to prevent data conflict between ROM or the like, which is slow to turn the read buffer off, and fast memories and I/O interfaces. Even when access is to the same space, idle cycles must be inserted when a read access is followed immediately by a write access. The idle cycles to be inserted comply with the specification for the previously accessed space. The set values below show the minimum number of idle cycles; more cycles than indicated by the Idles between Cycles setting may actually be inserted.

IW31, IW21, IW11, IW01	IW30, IW20, IW10, IW00	Description
0	0	No idle cycle
	1	One idle cycle inserted
1	0	Two idle cycles inserted (Initial value)
	1	Four idle cycles inserted

Bits 7 to 0—Wait Control for Areas 3 to 0 (W31–W00)

- When the CS_n space is set as ordinary space, the number of CS_n space waits can be specified with W_{n1} and W_{n0}.

W31, W21, W11, W01	W30, W20, W10, W00	Description
0	0	External wait input disabled without wait
	1	External wait input enabled with one wait
1	0	External wait input enabled with two waits
	1	Complies with the long wait specification of bus control register 1, 3 (BCR1, BCR3). External wait input is enabled (Initial value)

- When CS3 is DRAM, the number of $\overline{\text{CAS}}$ assert cycles is specified by wait control bits W31 and W30

Bit 7: W31	Bit 6: W30	Description
0	0	1 cycle
	1	2 cycles
1	0	3 cycles
	1	Reserved (do not set)

When external wait mask bit A3WM in WCR2 is 0 and the number of $\overline{\text{CAS}}$ assert cycles is set to 2 or more, external wait input is enabled.

- When CS2 or CS3 is synchronous DRAM, CAS latency is specified by wait control bits W31 and W30, and W21 and W20, respectively

W31, W21	W30, W20	Description
0	0	1 cycle
	1	2 cycles
1	0	3 cycles
	1	4 cycles (Initial value)

With synchronous DRAM, external wait input is ignored regardless of any setting.

7.2.5 Wait Control Register 2 (WCR2)

Bit:	15	14	13	12	11	10	9	8
	A4WD1	A4WD0	—	A4WM	A3WM	A2WM	A1WM	A0WM
Initial value:	0	0	0	0	0	0	0	0
R/W:	R/W	R/W	R	R/W	R/W	R/W	R/W	R/W
Bit:	7	6	5	4	3	2	1	0
	—	—	—	—	IW41	IW40	W41	W40
Initial value:	0	0	0	0	1	0	1	1
R/W:	R	R	R	R	R/W	R/W	R/W	R/W

Bits 15 and 14—Number of External Waits Specification for Area 4 (A4WD1, A4WD0): These bits specify the number of cycles between acceptance of CS4 space external wait negation and \overline{RD} or \overline{WEn} negation.

Bit 15: A4WD1	Bit 14: A4WD0	Description
0	0	1 cycle (Initial value)
	1	2 cycles
1	0	4 cycles
	1	Reserved (do not set)

Bit 13—Reserved bit. This bit is always read as 0. The write value should always be 0.

Bits 12 to 8—External Wait Mask Specification for Areas 0 to 4 (A4WM–A0WM): These bits enable waits to be masked for CS spaces 0 to 4. When a value other than 00 is set in the wait control bits for CS spaces 0 to 4 (W41–W00), external wait input can be enabled, but the wait input can be masked by setting these bits to 1. With synchronous DRAM, external wait input is ignored regardless of the settings.

A4WM	W41	W40	Description
A3WM	W31	W30	
A2WM	W21	W20	
A1WM	W11	W10	
A0WM	W01	W00	
0	0	0	External wait input ignored
		1	External wait input enabled
	1	0	External wait input enabled
		1	External wait input enabled (Initial value)
1	Don't care	Don't care	External wait input ignored

Bits 7 to 4—Reserved bits: These bits are always read as 0. The write value should always be 0.

Bits 3 and 2—Idles between Cycles for Area 4 (IW41, IW40): These bits specify idle cycles inserted between cycles in CS4 in the same way as for CS 0 to 3. The set values below show the minimum number of idle cycles; more cycles than indicated by the Idles between Cycles setting may actually be inserted.

Bit 3: IW41	Bit 2: IW40	Description
0	0	No idle cycle
	1	One idle cycle inserted
1	0	Two idle cycles inserted (Initial value)
	1	Four idle cycles inserted

Bits 1 and 0—Wait Control for Area 4 (W41, W40): These bits specify waits for CS4 in the same way as for areas 0 to 3.

Bit 1: W41	Bit 0: W40	Description
0	0	No wait. External wait input disabled without wait
	1	One wait. External wait input enabled with one wait
1	0	Two waits. External wait input enabled with two waits
	1	Complies with the long wait specification of bus control registers 1 and 3 (BCR1, BCR3). External wait input is enabled (Initial value)

7.2.6 Wait Control Register 3 (WCR3)

Bit:	15	14	13	12	11	10	9	8
	—	—	A4SW2	A4SW1	A4SW0	—	A4HW1	A4HW0
Initial value:	0	0	0	0	0	0	0	0
R/W:	R	R	R/W	R/W	R/W	R	R/W	R/W

Bit:	7	6	5	4	3	2	1	0
	A3SHW1	A3SHW0	A2SHW1	A2SHW0	A1SHW1	A1SHW0	A0SHW1	A0SHW0
Initial value:	0	0	0	0	0	0	0	0
R/W:	R/W	R/W	R/W	R/W	R/W	R/W	R/W	R/W

Bits 15 and 14—Reserved bits: These bits are always read as 0. The write value should always be 0.

Bits 13 to 11—CS4 Address/ $\overline{\text{CS4}}$ to $\overline{\text{RD}}/\overline{\text{WEn}}$ Assertion (A4SW2–A4SW0): These bits specify the number of cycles from address/ $\overline{\text{CS4}}$ output to $\overline{\text{RD}}/\overline{\text{WEn}}$ assertion for the CS4 space.

Bit 13: A4SW2	Bit 12: A4SW1	Bit 11: A4SW0	Description
0	0	0	0.5 cycles (Initial value)
		1	1.5 cycles
	1	0	3.5 cycles
		1	5.5 cycles
1	0	0	7.5 cycles
		1	Reserved (do not set)
	1	0	Reserved (do not set)
		1	Reserved (do not set)

Bit 10—Reserved bit: This bit is always read as 0. The write value should always be 0.

Bits 9 and 8—Area 4 $\overline{\text{RD}}/\overline{\text{WEn}}$ Negation to Address/ $\overline{\text{CS4}}$ Hold (A4HW1, A4HW0): These bits specify the number of cycles from $\overline{\text{RD}}/\overline{\text{WEn}}$ negation to address/ $\overline{\text{CS4}}$ hold for the CS4 space.

Bit 9: A4HW1	Bit 8: A4HW0	Description
0	0	0.5 cycle, $\overline{\text{CS4}}$ hold cycle = 0 cycles (Initial value)
	1	1.5 cycle, $\overline{\text{CS4}}$ hold cycle = 1 cycle
1	0	3.5 cycle, $\overline{\text{CS4}}$ hold cycle = 3 cycles
	1	5.5 cycle, $\overline{\text{CS4}}$ hold cycle = 5 cycles

Bits 7 to 0—Area 3 to 0 $\overline{\text{CSn}}$ Assert Period Extension (A3SHW1–A0SHW0): These bits specify the number of cycles from address/ $\overline{\text{CSn}}$ output to $\overline{\text{RD}}/\overline{\text{WEn}}$ assertion and from $\overline{\text{RD}}/\overline{\text{WEn}}$ negation to address/ $\overline{\text{CSn}}$ hold for areas 3 to 0.

A3SHW1	A3SHW0	Description
A2SHW1	A2SHW0	
A1SHW1	A1SHW0	
A0SHW1	A0SHW0	
0	0	0.5 cycle, $\overline{\text{CSn}}^*$ hold cycle = 0 cycles (Initial value)
	1	1.5 cycle, $\overline{\text{CSn}}^*$ hold cycle = 1 cycle
1	0	2.5 cycle, $\overline{\text{CSn}}^*$ hold cycle = 2 cycles
	1	Reserved (do not set)

Note: *n = 0 to 3

7.2.7 Individual Memory Control Register (MCR)

Bit:	15	14	13	12	11	10	9	8
	TRP0	RCD0	TRWL0	TRAS1	TRAS0	BE	RASD	TRWL1
Initial value:	0	0	0	0	0	0	0	0
R/W:	R/W	R/W	R/W	R/W	R/W	R/W	R/W	R/W

Bit:	7	6	5	4	3	2	1	0
	AMX2	SZ	AMX1	AMX0	RFSH	RMODE	TRP1	RCD1
Initial value:	0	0	0	0	0	0	0	0
R/W:	R/W	R/W	R/W	R/W	R/W	R/W	R/W	R/W

The TRP1–TRP0, RCD1–RCD0, TRWL1–TRWL0, TRAS1–TRAS0, BE, RASD, AMX2–AMX0 and SZ bits are initialized after a power-on reset. Do not write to them thereafter. When writing to them, write the same values as they are initialized to. Do not access CS2 or CS3 until register initialization is completed.

Bits 1 and 15— $\overline{\text{RAS}}$ Precharge Time (TRP1, TRP0): When DRAM is connected, specifies the minimum number of cycles after $\overline{\text{RAS}}$ is negated before the next assert. When synchronous DRAM is connected, specifies the minimum number of cycles after precharge until a bank active command is output. See section 7.5, Synchronous DRAM Interface, for details.

Bit 1: TRP1	Bit 15: TRP0	Description
0	0	1 cycle (Initial value)
	1	2 cycles
1	0	Reserved (do not set)
	1	Reserved (do not set)

Bits 0 and 14— $\overline{\text{RAS}}$ - $\overline{\text{CAS}}$ Delay (RCD1, RCD0): When DRAM is connected, specifies the number of cycles after $\overline{\text{RAS}}$ is asserted before $\overline{\text{CAS}}$ is asserted. When synchronous DRAM is connected, specifies the number of cycles after a bank active (ACTV) command is issued until a read or write command (READ, READA, WRIT, WRITA) is issued.

Bit 0: RCD1	Bit 14: RCD0	Description
0	0	1 cycle (Initial value)
	1	2 cycles
1	0	3 cycles
	1	Reserved (do not set)

Bits 8 and 13—Write-Precharge Delay (TRWL1, TRWL0): When the synchronous DRAM is not in the bank active mode, this bit specifies the number of cycles after the write cycle before the start-up of the auto-precharge. Based on this number of cycles, the timing at which the next active command can be issued is calculated within the bus controller. In bank active mode, this bit specifies the number of cycles before the precharge command is issued after the write command is issued. This bit is ignored when memory other than synchronous DRAM is connected.

Bit 8: TRWL1	Bit 13: TRWL0	Description
0	0	1 cycle (Initial value)
	1	2 cycles
1	0	3 cycles
	1	Reserved (do not set)

Bits 12 and 11— $\overline{\text{CAS}}$ -Before- $\overline{\text{RAS}}$ Refresh $\overline{\text{RAS}}$ Assert Time (TRAS1, TRAS0): These bits specify the $\overline{\text{RAS}}$ assertion width when DRAM is connected.

Bit 12: TRAS1	Bit 11: TRAS0	Description
0	0	2 cycles (Initial value)
	1	3 cycles
1	0	4 cycles
	1	5 cycles

After an auto-refresh command is issued, a bank active command is not issued for TRAS cycles, regardless of the TRP bit setting. For synchronous DRAM, there is no $\overline{\text{RAS}}$ assertion period, but there is a limit for the time from the issue of a refresh command until the next access. This value is set to observe this limit. Commands are not issued for TRAS cycles when self-refresh is cleared.

Bit 12: TRAS1	Bit 11: TRAS0	Description
0	0	3 cycles (Initial value)
	1	4 cycles
1	0	6 cycles
	1	9 cycles

Bit 10—Burst Enable (BE)

Bit 10: BE	Description
0	Burst disabled (Initial value)
1	High-speed page mode during DRAM and ED0 interfacing is enabled. Burst access conditions are as follows: <ul style="list-style-type: none"> • Longword access, cache fill access, or DMAC 16-byte transfer, with 16-bit bus width • Cache fill access or DMAC 16-byte transfer, with 32-bit bus width During synchronous DRAM access, burst operation is always enabled regardless of this bit

Bit 9—Bank Active Mode (RASD)

Bit 9: RASD	Description
0	For DRAM, $\overline{\text{RAS}}$ is negated after access ends (normal operation) For synchronous DRAM, a read or write is performed using auto-precharge mode. The next access always starts with a bank active command (Initial value)
1	For DRAM, after access ends $\overline{\text{RAS}}$ down mode is entered in which RAS is left asserted. When using this mode with an external device connected which performs writes other than to DRAM, see section 7.6.5, Burst Access For synchronous DRAM, access ends in the bank active state. This is only valid for area 3. When area 2 is synchronous DRAM, the mode is always auto-precharge

Bits 7, 5, and 4—Address Multiplex (AMX2–AMX0)

- For DRAM interface

Bit 7: AMX2	Bit 5: AMX1	Bit 4: AMX0	Description
0	0	0	8-bit column address DRAM
		1	9-bit column address DRAM
	1	0	10-bit column address DRAM
		1	11-bit column address DRAM
1	0	0	Reserved (do not set)
		1	Reserved (do not set)
	1	0	Reserved (do not set)
		1	Reserved (do not set)

- For synchronous DRAM interface

Bit 7: AMX2	Bit 5: AMX1	Bit 4: AMX0	Description
0	0	0	16-Mbit DRAM (1M × 16 bits), 64-Mbit DRAM (2M × 32 bits)* ²
		1	16-Mbit DRAM (2M × 8 bits)* ¹
	1	0	16-Mbit DRAM (4M × 4 bits)* ¹
		1	4-Mbit DRAM (256k × 16 bits)
1	0	0	64-Mbit DRAM (4M × 16 bits)
		1	64-Mbit DRAM (8M × 8 bits)* ¹
	1	0	Reserved (do not set)
		1	2-Mbit DRAM (128k × 16 bits)

Notes: *¹ Reserved. Do not set when SZ bit in MCR is 0 (16-bit bus width).

*² See section 7.5.11 for the method of connection to a 64-Mbit DRAM with a 2M × 32-bit configuration.

Bit 6—Memory Data Size (SZ): For synchronous DRAM and DRAM space, the data bus width of BCR2 is ignored in favor of the specification of this bit.

Bit 6: SZ	Description
0	Word (16 bits) (Initial value)
1	Longword (32 bits)

Bit 3—Refresh Control (RFSH): This bit determines whether or not the refresh operation of DRAM/synchronous DRAM is performed.

Bit 3: RFSH	Description
0	No refresh (Initial value)
1	Refresh

Bit 2—Refresh Mode (RMODE): When the RFSH bit is 1, this bit selects normal refresh or self-refresh. When the RFSH bit is 0, do not set this bit to 1. When the RFSH bit is 1, self-refresh mode is entered immediately after the RMODE bit is set to 1. When the RFSH bit is 1 and this bit is 0, a $\overline{\text{CAS}}$ -before- $\overline{\text{RAS}}$ refresh or auto-refresh is performed at the interval set in the 8-bit interval timer. When a refresh request occurs during an external area access, the refresh is performed after the access cycle is completed. When set for self-refresh, self-refresh mode is entered immediately unless the chip is in the middle of a synchronous DRAM area access, in which case self-refresh mode is entered when the access ends. Refresh requests from the interval timer are ignored during self-refresh.

Bit 2: RMODE	Description
0	Normal refresh (Initial value)
1	Self-refresh

7.2.8 Refresh Timer Control/Status Register (RTCSR)

Bit:	15	14	13	12	11	10	9	8
	—	—	—	—	—	—	—	—
Initial value:	0	0	0	0	0	0	0	0
R/W:	R	R	R	R	R	R	R	R
Bit:	7	6	5	4	3	2	1	0
	CMF	CMIE	CKS2	CKS1	CKS0	RRC2	RRC1	RRC0
Initial value:	0	0	0	0	0	0	0	0
R/W:	R/W	R/W	R/W	R/W	R/W	R/W	R/W	R/W

Bits 15 to 8—Reserved: These bits are always read as 0. The write value should always be 0.

Bit 7—Compare Match Flag (CMF): This status flag, which indicates that the values of RTCNT and RTCOR match, is set/cleared under the following conditions:

Bit 7: CMF	Description
0	[Clearing condition] After RTCSR is read when CMF is 1, 0 is written in CMF
1	[Setting condition] RTCNT = RTCOR

Bit 6—Compare Match Interrupt Enable (CMIE): Enables or disables an interrupt request caused by the CMF bit of RTCSR when CMF is set to 1.

Bit 6: CMIE	Description
0	Interrupt request caused by CMF is disabled (Initial value)
1	Interrupt request caused by CMF is enabled

Bits 5 to 3—Clock Select Bits (CKS2–CKS0)

Bit 5: CKS2	Bit 4: CKS1	Bit 3: CKS0	Description
0	0	0	Count-up disabled (Initial value)
		1	$P\phi/4$
	1	0	$P\phi/16$
1	0	1	$P\phi/64$
		0	$P\phi/256$
	1	0	$P\phi/1024$
		1	$P\phi/2048$
1	1	0	$P\phi/2048$
		1	$P\phi/4096$

Bits 2 to 0—Refresh Count (RRC2–RRC0): These bits specify the number of consecutive refreshes to be performed when the refresh timer counter (RTCNT) and refresh time constant register (RTCOR) values match and a refresh request is issued.

Bit 2: RRC2	Bit 1: RRC1	Bit 0: RRC0	Description
0	0	0	1 refresh (Initial value)
		1	2 refreshes
	1	0	4 refreshes
		1	6 refreshes
1	0	0	8 refreshes
		1	Reserved (do not set)
	1	0	Reserved (do not set)
		1	Reserved (do not set)

7.2.9 Refresh Timer Counter (RTCNT)

Bit:	15	14	13	12	11	10	9	8
	—	—	—	—	—	—	—	—
Initial value:	0	0	0	0	0	0	0	0
R/W:	R	R	R	R	R	R	R	R
Bit:	7	6	5	4	3	2	1	0
Initial value:	0	0	0	0	0	0	0	0
R/W:	R/W	R/W	R/W	R/W	R/W	R/W	R/W	R/W

The 8-bit counter RTCNT counts up with input clocks. The clock select bit of RTCSR selects an input clock. RTCNT values can always be read/written by the CPU. When RTCNT matches RTCOR, RTCNT is cleared. Returns to 0 after it counts up to 255.

Bits 15 to 8—Reserved: These bits are always read as 0. The write value should always be 0.

7.2.10 Refresh Time Constant Register (RTCOR)

Bit:	15	14	13	12	11	10	9	8
	—	—	—	—	—	—	—	—
Initial value:	0	0	0	0	0	0	0	0
R/W:	R	R	R	R	R	R	R	R
Bit:	7	6	5	4	3	2	1	0
Initial value:	0	0	0	0	0	0	0	0
R/W:	R/W	R/W	R/W	R/W	R/W	R/W	R/W	R/W

RTCOR is an 8-bit read/write register. The values of RTCOR and RTCNT are constantly compared. When the values correspond, the compare match flag (CMF) in RTCSR is set and RTCNT is cleared to 0. When the refresh bit (RFSH) in the individual memory control register (MCR) is set to 1, a refresh request signal occurs. The refresh request signal is held until refresh operation is actually performed. If the refresh request is not processed before the next match, the previous request becomes ineffective.

When the CMIE bit in RTCSR is set to 1, an interrupt request is sent to the controller by this match signal. The interrupt request is output continuously until the CMF bit in RTCSR is cleared. When the CMF bit clears, it only affects the interrupt; the refresh request is not cleared by this operation. When a refresh is performed and refresh requests are counted using interrupts, a refresh can be set simultaneously with the interval timer interrupt.

Bits 15 to 8—Reserved: These bits are always read as 0. The write value should always be 0.

7.3 Access Size and Data Alignment

7.3.1 Connection to Ordinary Devices

Byte, word, and longword are supported as access units. Data is aligned based on the data width of the device. Therefore, reading longword data from a byte-width device requires four read operations. The bus state controller automatically converts data alignment and data length between interfaces. An 8-bit, 16-bit, or 32-bit external device data width can be connected by using the mode pins for the CS0 space, or by setting BCR2 for the CS1–CS4 spaces. However, the data width of devices connected to the respective spaces is specified statically, and the data width cannot be changed for each access cycle. Figures 7.2 to 7.4 show the relationship between device data widths and access units.

32-bit external device (ordinary)

A24-A0	D31	D23	D15	D7	D0	Data input/output pin			
000000	7	0				Byte read/write of address 0			
000001		7	0			Byte read/write of address 1			
000002			7	0		Byte read/write of address 2			
000003				7	0	Byte read/write of address 3			
000000	15	8	7	0		Word read/write of address 0			
000002			15	8	7	0	Word read/write of address 2		
000000	31	24	23	16	15	8	7	0	Longword read/write of address 0

Figure 7.2 32-Bit External Devices and Their Access Units

16-bit external device (ordinary)

A24-A0	D15	D7	D0	Data input/output pin
000000	7	0		Byte read/write of address 0
000001		7	0	Byte read/write of address 1
000002	7	0		Byte read/write of address 2
000003		7	0	Byte read/write of address 3
000000	15		0	Word read/write of address 0
000002	15		0	Word read/write of address 2
000000	31		16	} Longword read/write of address 0
000002	15		0	

Figure 7.3 16-Bit External Devices and Their Access Units

8-bit external device (ordinary)

A24-A0	D7	D0	Data input/output pin
000000	7	0	Byte read/write of address 0
000001	7	0	Byte read/write of address 1
000002	7	0	Byte read/write of address 2
000003	7	0	Byte read/write of address 3
000000	15	8	} Word read/write of address 0
000001	7	0	
000002	15	8	} Word read/write of address 2
000003	7	0	
000000	31	24	} Longword read/write of address 0
000001	23	16	
000002	15	8	
000003	7	0	

Figure 7.4 8-Bit External Devices and Their Access Units

7.3.2 Connection to Little-Endian Devices

The chip provides a conversion function in CS2, CS4 space for connection to and to maintain data compatibility with devices that use little-endian format (in which the LSB is the 0 position in the byte data lineup). When the endian specification bit of BCR1 is set to 1, CS2, CS4 space is little-endian. The relationship between device data width and access unit for little-endian format is shown in figures 7.5, 7.6, and 7.7. When sharing memory or the like with a little-endian bus master, the SH7616 connects D31–D24 to the least significant byte (LSB) of the other bus master and D7–D0 to the most significant byte (MSB), when the bus width is 32 bits. When the width is 16 bits, the SH7616 connects D15–D8 to the least significant byte of the other bus master and D7–D0 to the most significant byte.

Only data conversion is supported by this function. For this reason, be careful not to place program code or constants in the CS2, CS4 space. When this function is used, make sure that the access unit is the same for writing and reading. For example, data written by longword access should be read by longword access. If the read access unit is different from the write access unit, an incorrect value will be read.

32-bit external device (little-endian)						
A24–A0	D31	D23	D15	D7	D0	Data input/output pin
000000	<u>7 0</u>					Byte read/write of address 0
000001		<u>7 0</u>				Byte read/write of address 1
000002			<u>7 0</u>			Byte read/write of address 2
000003				<u>7 0</u>		Byte read/write of address 3
000000	<u>7 0, 15 8</u>					Word read/write of address 0
000002			<u>7 0, 15 8</u>			Word read/write of address 2
000000	<u>7 0, 15 8</u>		<u>23 16, 31 24</u>			Longword read/write of address 0

Figure 7.5 32-Bit External Devices and Their Access Units

16-bit external device (little-endian)					
A24–A0	D15	D7	D0	Data input/output pin	
000000	<u>7 0</u>			Byte read/write of address 0	
000001		<u>7 0</u>		Byte read/write of address 1	
000002	<u>7 0</u>			Byte read/write of address 2	
000003		<u>7 0</u>		Byte read/write of address 3	
000000	<u>7 0, 15 8</u>			Word read/write of address 0	
000002	<u>7 0, 15 8</u>			Word read/write of address 2	
000000	<u>7 0, 15 8</u>		<u>23 16, 31 24</u>		Longword read/write of address 0
000002	<u>23 16, 31 24</u>				

Figure 7.6 16-Bit External Devices and Their Access Units

8-bit external device (little-endian)

A24–A0	D7	D0	Data input/output pin
000000	7	0	Byte read/write of address 0
000001	7	0	Byte read/write of address 1
000002	7	0	Byte read/write of address 2
000003	7	0	Byte read/write of address 3
000000	7	0	} Word read/write of address 0
000001	15	8	
000002	7	0	} Word read/write of address 2
000003	15	8	
000000	7	0	} Longword read/write of address 0
000001	15	8	
000002	23	16	
000003	31	24	

Figure 7.7 8-Bit External Devices and Their Access Units

7.4 Accessing Ordinary Space

7.4.1 Basic Timing

A strobe signal is output by ordinary space accesses of CS0–CS4 spaces to provide primarily for SRAM direct connections. Figure 7.8 shows the basic timing of ordinary space accesses. Ordinary accesses without waits end in 2 cycles. The \overline{BS} signal is asserted for 1 cycle to indicate the start of the bus cycle. The \overline{CSn} signal is negated by the fall of clock T2 to ensure the negate period. The negate period is thus half a cycle when accessed at the minimum pitch.

The access size is not specified during a read. The correct access start address will be output to the LSB of the address, but since no access size is specified, the read will always be 32 bits for 32-bit devices and 16 bits for 16-bit devices. For writes, only the \overline{WE} signal of the byte that will be written is asserted. For 32-bit devices, $\overline{WE3}$ specifies writing to a $4n$ address and $\overline{WE0}$ specifies writing to a $4n+3$ address. For 16-bit devices, $\overline{WE1}$ specifies writing to a $2n$ address and $\overline{WE0}$ specifies writing to a $2n+1$ address. For 8-bit devices, only $\overline{WE0}$ is used.

When data buses are provided with buffers, the \overline{RD} signal must be used for data output in the read direction. When RD/\overline{WR} signals do not perform accesses, the chip stays in read status, so there is a danger of conflicts occurring with output when this is used to control the external data buffer.

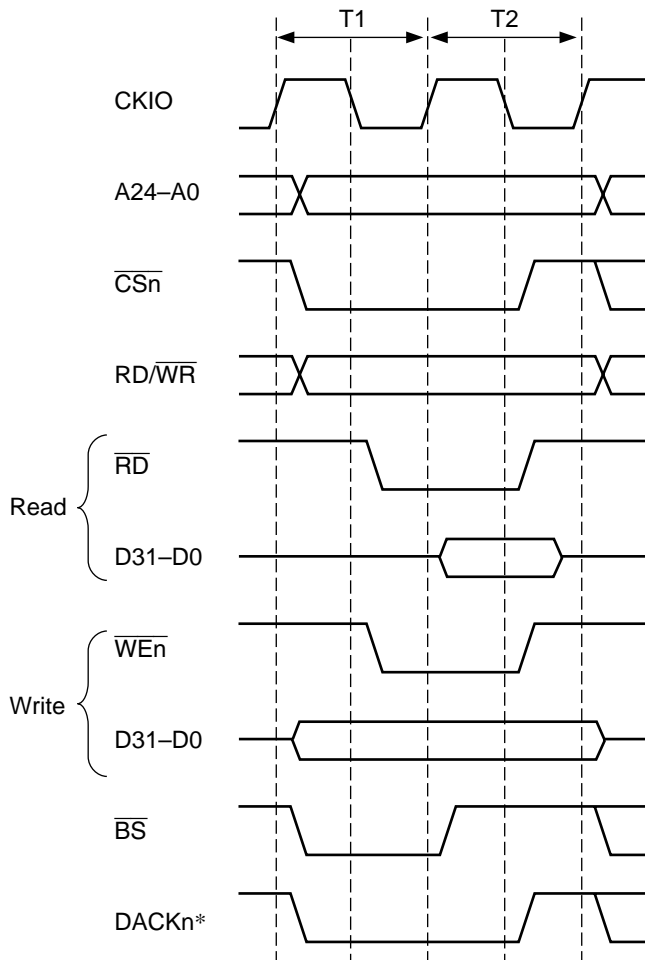

Note: * DACKn waveform when active-low is specified.

Figure 7.8 Basic Timing of Ordinary Space Access

When making a word or longword access with an 8-bit bus width, or a longword access with a 16-bit bus width, the bus state controller performs multiple accesses.

When clock ratio $I\phi : E\phi$ is other than 1 : 1, the basic timing shown in figure 7.8 is repeated, but when clock ratio $I\phi : E\phi$ is 1 : 1, burst access with no \overline{CSn} negate period is performed as shown in figure 7.9.

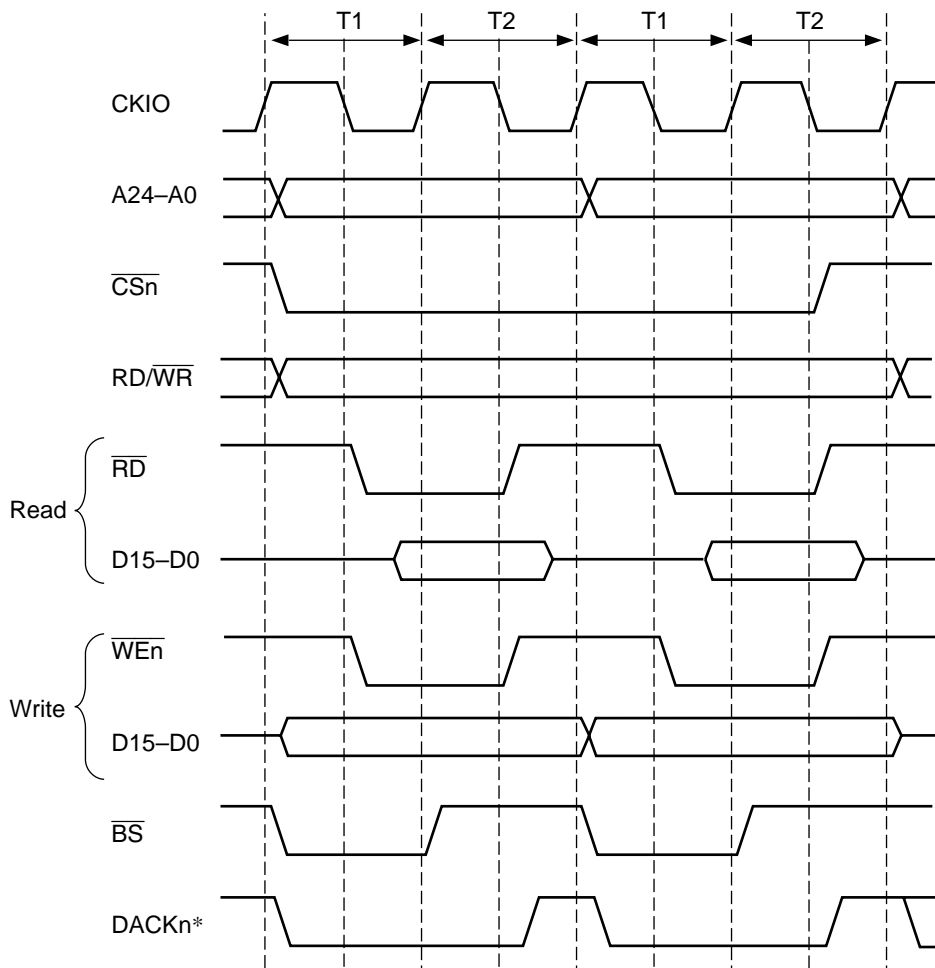

Note: * DACKn waveform when active-low is specified.

**Figure 7.9 Timing of Longword Access in Ordinary Space Using 16-Bit Bus Width
(Clock Ratio $I\phi : E\phi = 1 : 1$)**

Figure 7.10 shows an example of 32-bit data width SRAM connection, figure 7.11 an example of 16-bit data width SRAM connection, and figure 7.12 an example of 8-bit data width SRAM connection.

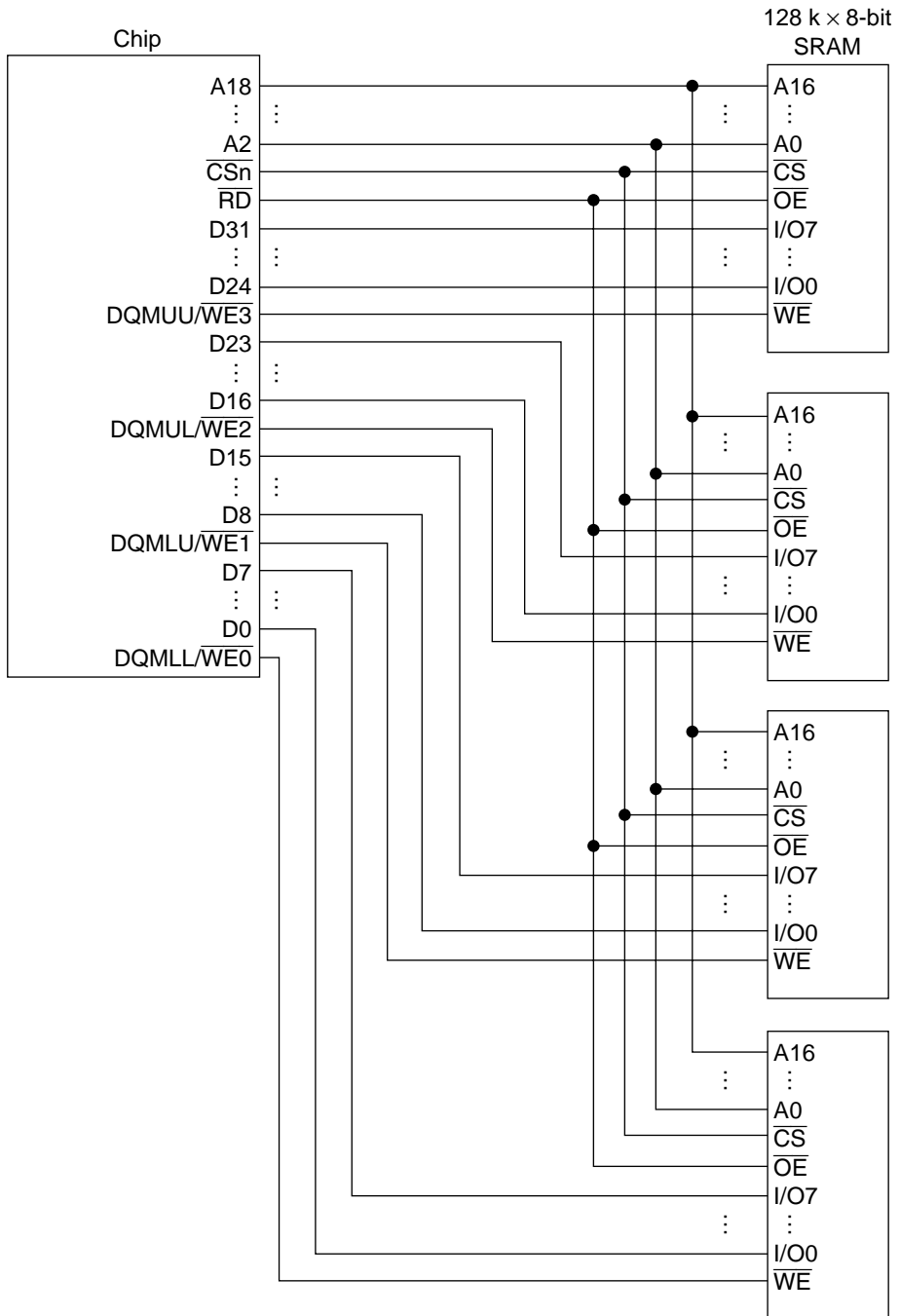

Figure 7.10 Example of 32-Bit Data Width SRAM Connection

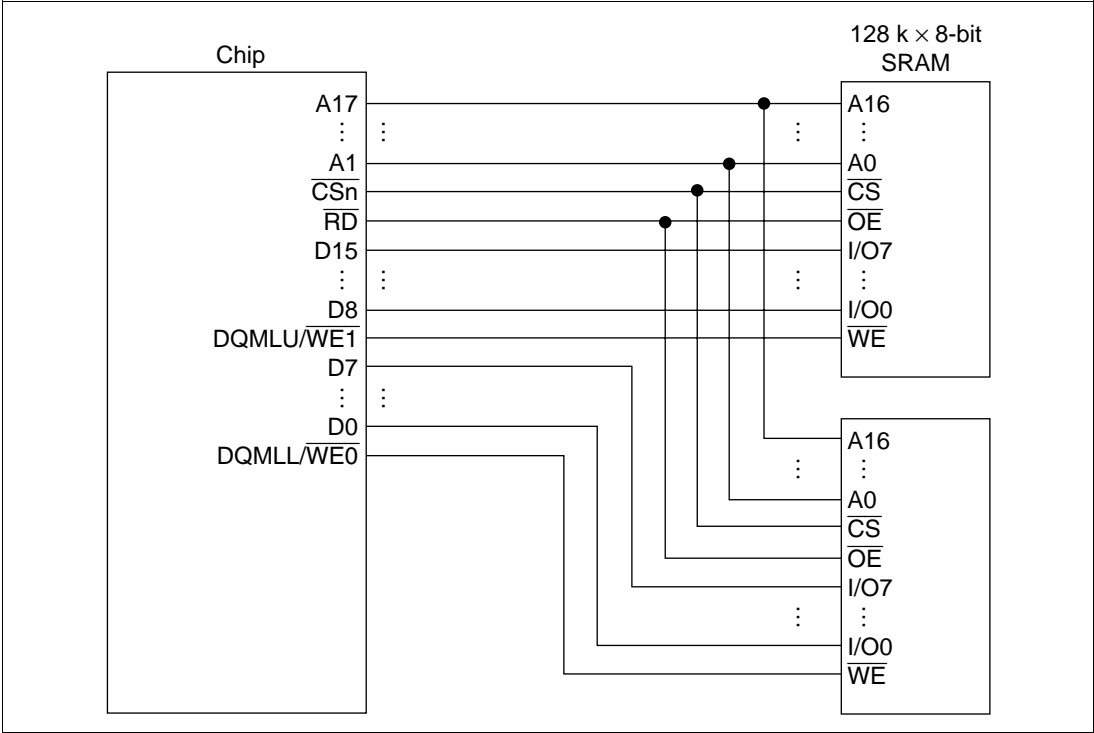

Figure 7.11 Example of 16-Bit Data Width SRAM Connection

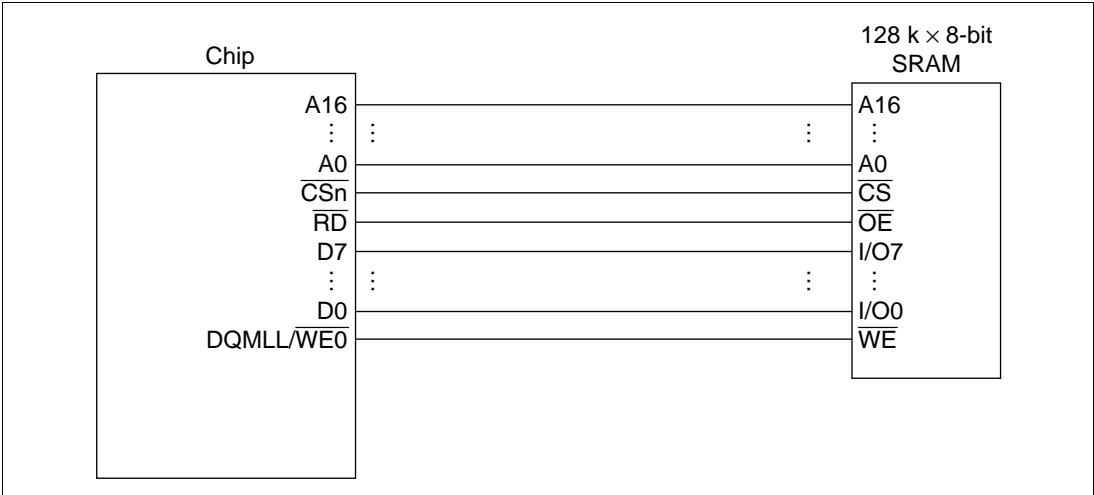

Figure 7.12 Example of 8-Bit Data Width SRAM Connection

7.4.2 Wait State Control

The number of wait states inserted into ordinary space access states can be controlled using the WCR1, WCR2, BCR1 and BCR3 register settings. When the W_n1 and W_n0 wait specification bits in WCR1, WCR2 for the given CS space are 01 or 10, software waits are inserted according to the wait specification. When W_n1 and W_n0 are 11, wait cycles are inserted according to the long wait specification bit $AnLW$ in BCR1, BCR3. The long wait specification in BCR1, BCR3 can be made independently for CS0, CS1 and CS4 spaces, but the same value must be specified for CS2 and CS3 spaces. All WCR1 specifications are independent. By means of WCR1, WCR2, BCR1, and BCR3, a T_w cycle is inserted as a wait cycle as long as the number of specified cycles at the wait timing for ordinary access space shown in figure 7.13. The names of the control bits that specify T_w for each CS space are shown in table 7.5.

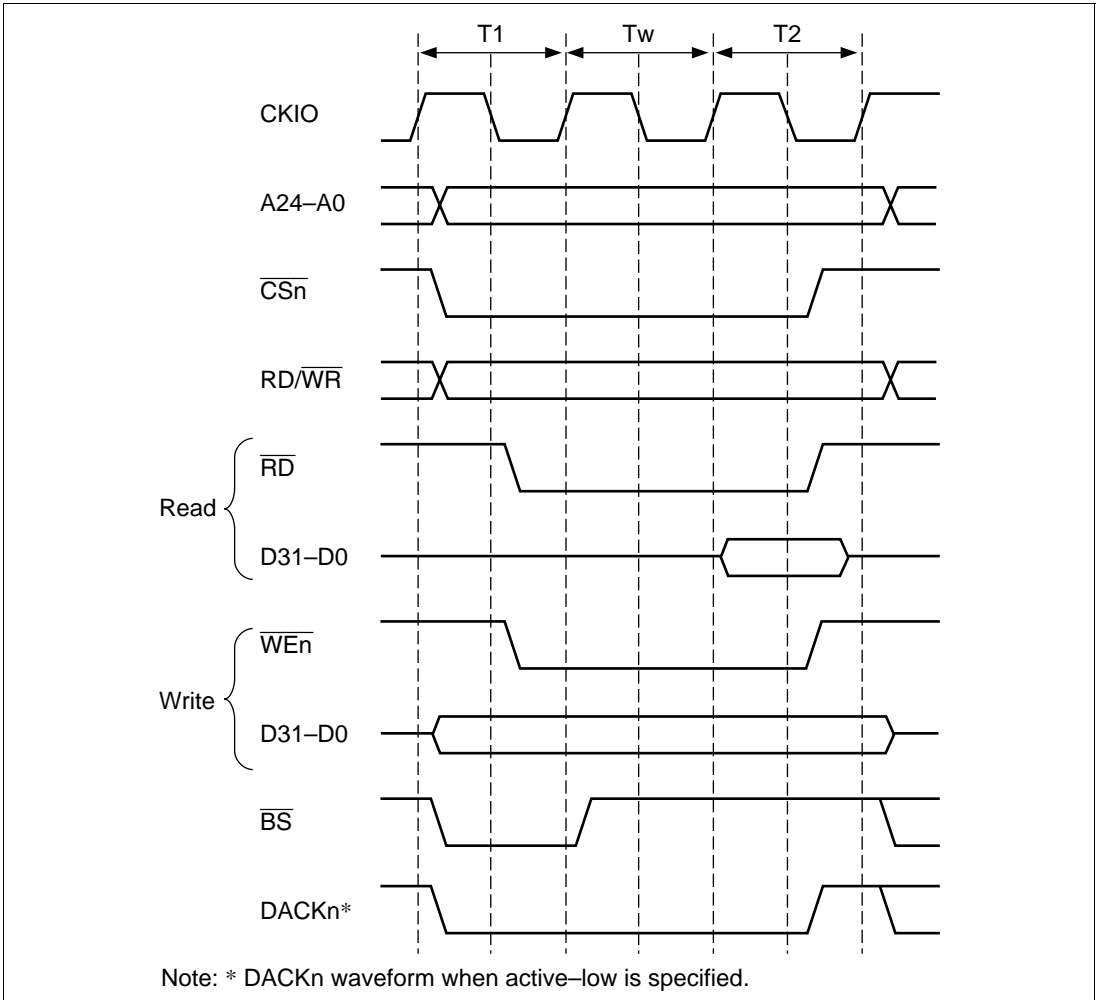
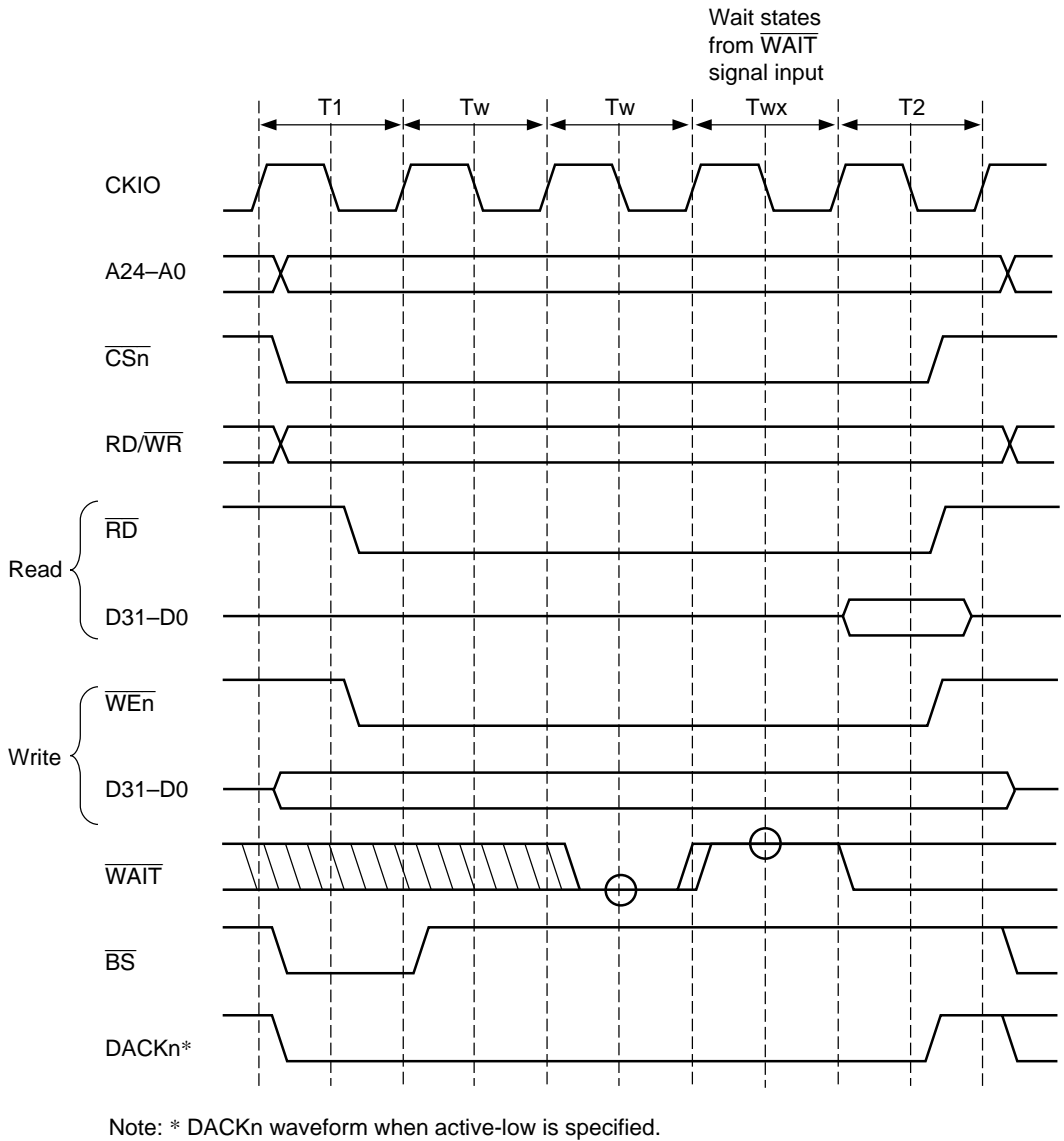

Figure 7.13 Wait Timing of Ordinary Space Access (Software Wait Only)

Table 7.5 CSn Spaces and Tw Specification Bits

	BCR3	BCR1	WCR1		WCR2		Tw	
CS0	A0LW2	A0LW1	A0LW0	W01	W00	—	—	0–14
CS1	A1LW2	A1LW1	A2LW0	W11	W10	—	—	0–14
CS2	AHLW2	AHLW1	AHLW0	W21	W20	—	—	0–14
CS3	AHLW2	AHLW1	AHLW0	W31	W30	—	—	0–14
CS4	A4LW2	A4LW1	A4LW0	—	—	W41	W40	0–14

When a wait is specified by software using WCR1 and WCR2 (W_{n1} , W_{n0}), and the external wait mask bit ($AnWM$) is cleared to 0 in WCR2, the wait input \overline{WAIT} signal from outside is sampled. Figure 7.14 shows \overline{WAIT} signal sampling. A 2-cycle wait is specified as a software wait. The sampling is performed when the Tw state shifts to the T2 state, so there is no effect even when the \overline{WAIT} signal is asserted in the T1 cycle or the first Tw cycle. The \overline{WAIT} signal is sampled at the clock fall.



**Figure 7.14 Wait State Timing of Ordinary Space Access
(Wait States from $\overline{\text{WAIT}}$ Signal)**

For the CS0–CS3 spaces, $\overline{\text{CSn}}$, $\overline{\text{RD}}$, and $\overline{\text{WEn}}$ are negated for one cycle after negation of the external wait signal is accepted, as shown in figure 7.14. For the CS4 space, the number of cycles before $\overline{\text{CSn}}$, $\overline{\text{RD}}$, and $\overline{\text{WEn}}$ are negated after acceptance of external wait negation can be set as 1, 2, or 4 by means of bits A4WD1 and A4WD0 in WCR2. Figure 7.15 shows an example.

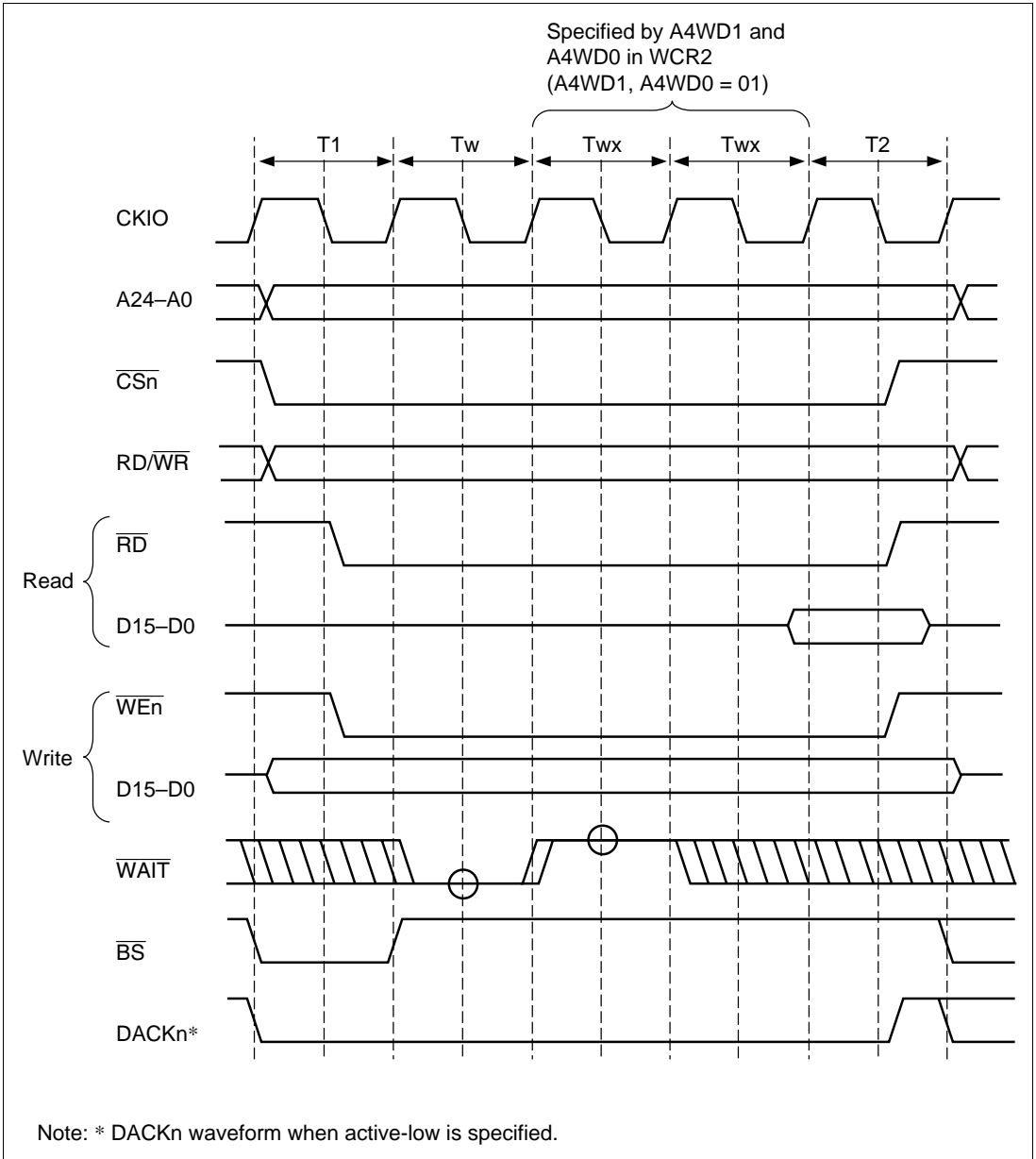

Figure 7.15 Wait State Timing of Ordinary Space in CS4 Space

7.4.3 $\overline{\text{CS}}$ Assertion Period Extension

Idle cycles can be inserted to prevent extension of the $\overline{\text{RD}}$ or $\overline{\text{WEn}}$ assertion period beyond the length of the $\overline{\text{CSn}}$ assertion period by setting control bits in WCR3. This allows for flexible interfacing to external circuit. The timing is shown in figure 7.16. T_h and T_f cycles are added respectively before and after the ordinary cycle. Signals other than $\overline{\text{RD}}$ and $\overline{\text{WEn}}$ are asserted in this cycle, but $\overline{\text{RD}}$ and $\overline{\text{WEn}}$ are not. In addition, data is extended up to the T_f cycle, which is effective for devices with slow write operations.

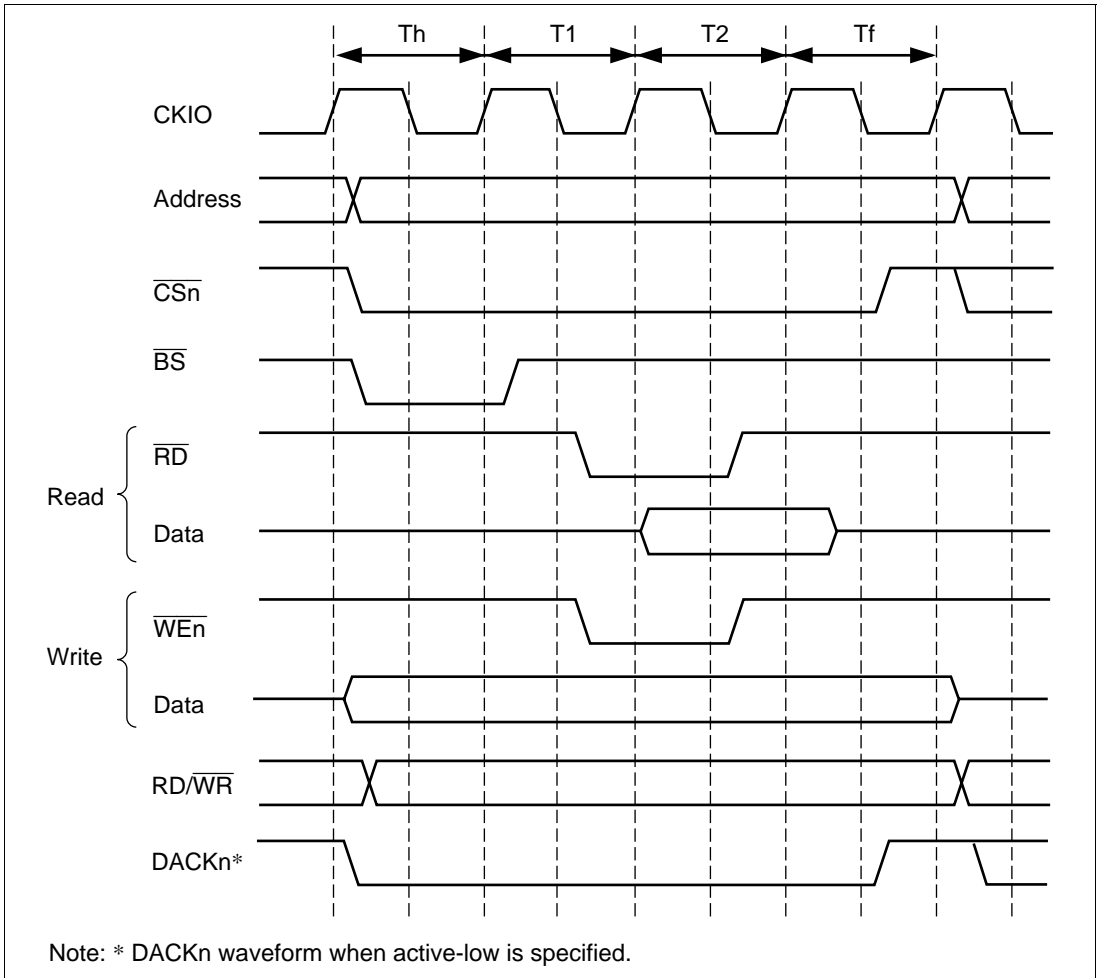

Figure 7.16 $\overline{\text{CS}}$ Assertion Period Extension Function

For the CS0–CS4 spaces, For spaces CS0—CS4, Th and Tf can be set as follows.

	Th	Tf	WCR3
CS0—3	0—2	0—2	AnSW1, AnSW0 (Th = Tf) n =0—3
CS4	0—7	0—5	Th: A4SW2—0 Tf: A4HW1—0

7.5 Synchronous DRAM Interface

7.5.1 Synchronous DRAM Direct Connection

Seven kinds of synchronous DRAM can be connected: 2-Mbit ($128k \times 16$), 4-Mbit ($256k \times 16$), 16-Mbit ($1M \times 16$, $2M \times 8$, and $4M \times 4$), and 64-Mbit ($4M \times 16$ and $8M \times 8$). This chip supports 64-Mbit synchronous DRAMs internally divided into two or four banks, and other synchronous DRAMs internally divided into two banks. Since synchronous DRAM can be selected by the \overline{CS} signal, CS2 and CS3 spaces can be connected using a common \overline{RAS} or other control signal. When the memory enable bits for DRAM and other memory (DRAM2–DRAM0) in BCR1 are set to 001, CS2 is ordinary space and CS3 is synchronous DRAM space. When the DRAM2–0 bits are set to 100, CS2 is synchronous DRAM space and CS3 is ordinary space. When the bits are set to 101, both CS2 and CS3 are synchronous DRAM spaces.

Supported synchronous DRAM operating modes are burst read/single write mode (initial setting) and burst read/burst write mode. The burst length depends on the data bus width, comprising 8 bursts for a 16-bit width, and 4 bursts for a 32-bit width. The data bus width is specified by the SZ bit in MCR. Burst operation is always performed, so the burst enable (BE) bit in MCR is ignored. Switching to burst write mode is performed by means of the BWE bit in BCR3.

Control signals for directly connecting synchronous DRAM are the \overline{RAS} , $\overline{CAS}/\overline{OE}$, RD/\overline{WR} , $\overline{CS2}$ or $\overline{CS3}$, DQM_{UU}, DQM_{UL}, DQML_U, DQML_L, and CKE signals. Signals other than $\overline{CS2}$ and $\overline{CS3}$ are common to every area, and signals other than CKE are valid and fetched only when $\overline{CS2}$ or $\overline{CS3}$ is true. Therefore, synchronous DRAM can be connected in parallel in multiple areas. CKE is negated (to the low level) only when a self-refresh is performed; otherwise it is always asserted (to the high level).

Commands can be specified for synchronous DRAM using the \overline{RAS} , $\overline{CAS}/\overline{OE}$, RD/\overline{WR} , and certain address signals. These commands are NOP, auto-refresh (REF), self-refresh (SELF), all-bank precharge (PALL), specific bank precharge (PRE), row address strobe/bank active (ACTV), read (READ), read with precharge (READA), write (WRIT), write with precharge (WRITA), and mode register write (MRS).

Bytes are specified using DQM_{UU}, DQM_{UL}, DQML_U, and DQML_L. The read/write is performed on the byte whose DQM is low. For 32-bit data, DQM_{UU} specifies 4n address access and DQML_L specifies 4n + 3 address access. For 16-bit data, only DQML_U and DQML_L are

used. Figure 7.17 shows an example in which a 32-bit connection uses a 256k × 16 bit synchronous DRAM. Figure 7.18 shows an example with a 16-bit connection.

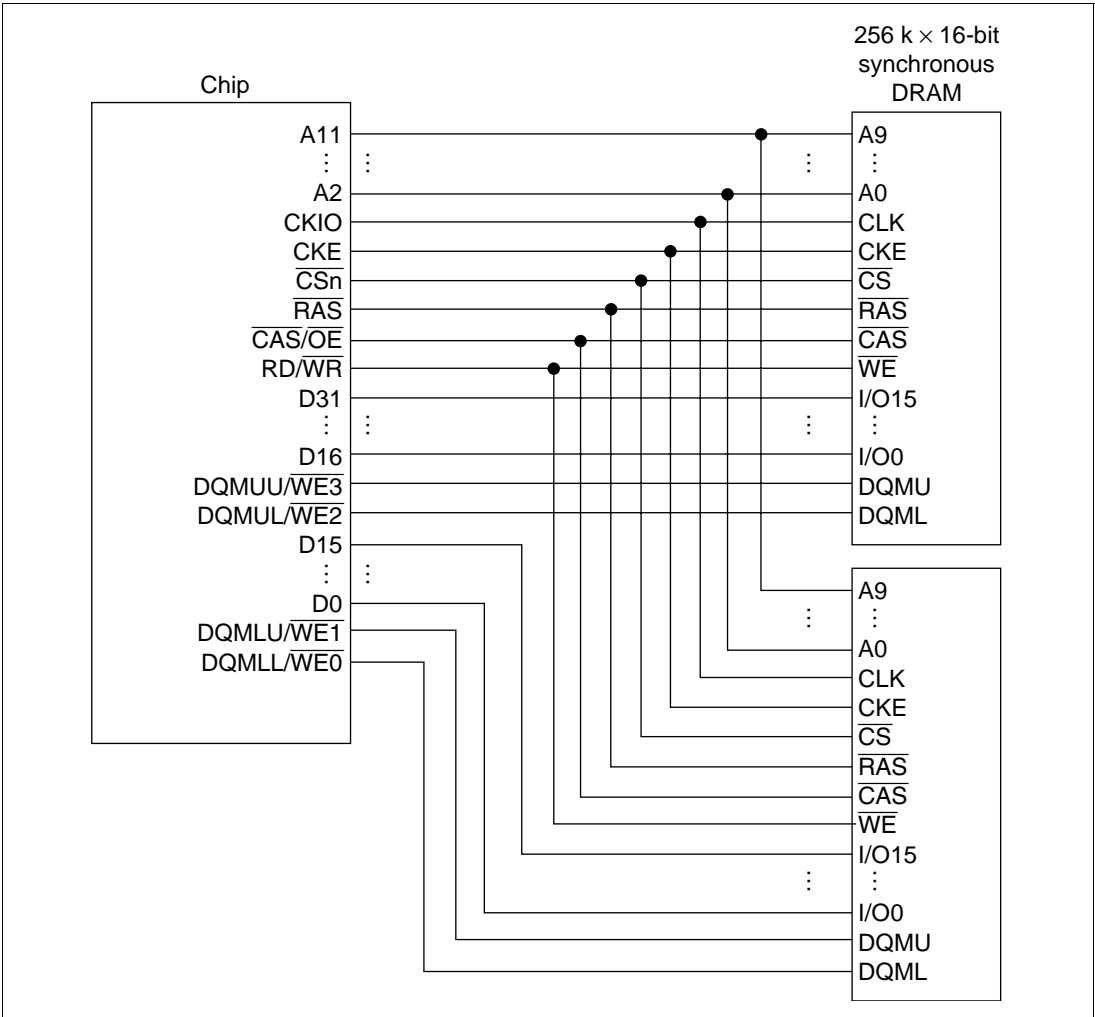

Figure 7.17 Synchronous DRAM 32-bit Device Connection

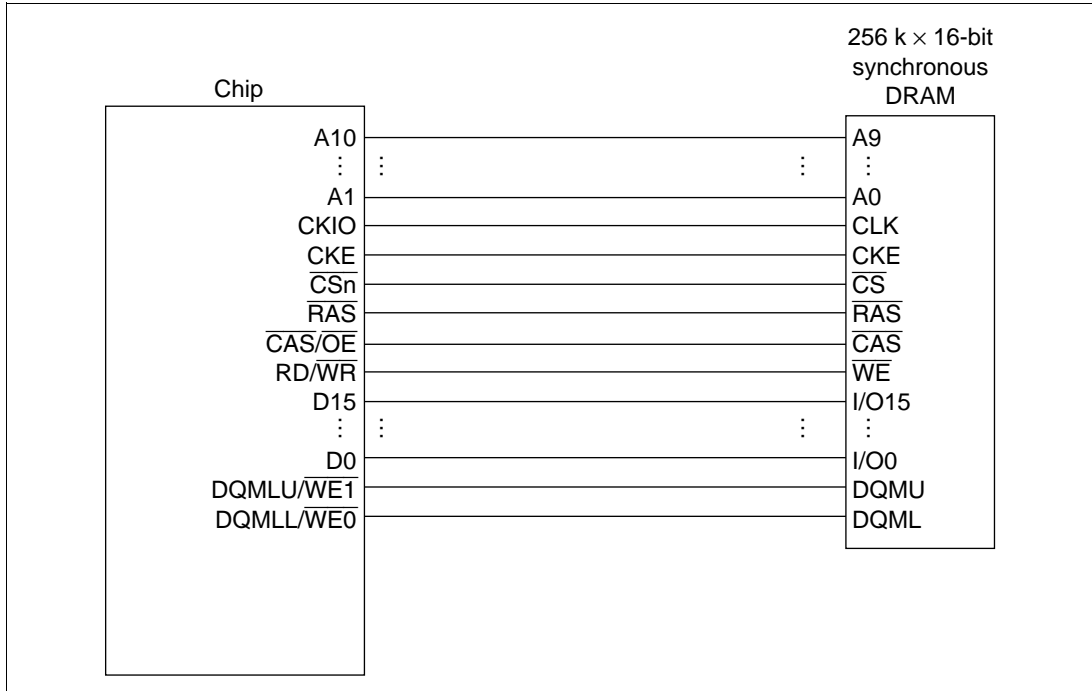

Figure 7.18 Synchronous DRAM 16-bit Device Connection

7.5.2 Address Multiplexing

Addresses are multiplexed according to the MCR's address multiplex specification bits AMX2–AMX0 and size specification bit SZ so that synchronous DRAMs can be connected to the SH7616 directly without an external multiplex circuit. Table 7.6 shows the relationship between the multiplex specification bits and bit output to the address pins.

A24–A16 always output the original value regardless of multiplexing.

When $SZ = 0$, the data width on the synchronous DRAM side is 16 bits and the LSB of the device's address pins (A0) specifies word address. The A0 pin of the synchronous DRAM is thus connected to the A1 pin of the SH7616, the rest of the connection proceeding in the same order, beginning with the A1 pin to the A2 pin.

When $SZ = 1$, the data width on the synchronous DRAM side is 32 bits and the LSB of the device's address pins (A0) specifies longword address. The A0 pin of the synchronous DRAM is thus connected to the A2 pin of the SH7616, the rest of the connection proceeding in the same order, beginning with the A1 pin to the A3 pin.

Table 7.6 SZ and AMX Bits and Address Multiplex Output

Setting				Output Timing	External Address Pins							
SZ	AMX2	AMX1	AMX0		A1–A8	A9	A10	A11	A12	A13	A14	A15
1	0	0	0	Column address	A1–A8	A9	A10	A11	L/H* ¹	A21* ²	A14	A15
				Row address	A9–A16	A17	A18	A19	A20	A21* ²	A22	A23
1	0	0	1	Column address	A1–A8	A9	A10	A11	L/H* ¹	A22* ²	A14	A15
				Row address	A10–A17	A18	A19	A20	A21	A22* ²	A23	A24
1	0	1	0	Column address	A1–A8	A9	A10	A11	L/H* ¹	A23* ²	A14	A15
				Row address	A11–A18	A19	A20	A21	A22	A23* ²	A24	A25
1	0	1	1	Column address	A1–A8	A9	L/H* ¹	A19* ²	A12	A13	A14	A15
				Row address	A9–A16	A17	A18	A19* ²	A20	A21	A22	A23
1	1	0	0	Column address	A1–A8	A9	A10	A11	L/H* ¹	A13	A22* ³	A23* ²
				Row address	A9–A16	A17	A18	A19	A20	A21	A22* ³	A23* ²
1	1	0	1	Column address	A1–A8	A9	A10	A11	L/H* ¹	A13	A23* ³	A24* ²
				Row address	A10–A17	A18	A19	A20	A21	A22	A23* ³	A24* ²
1	1	1	1	Column address	A1–A8	A9	L/H* ¹	A18* ²	A12	A13	A14	A15
				Row address	A9–A16	A17	A17	A18* ²	A20	A21	A22	A23
0	0	0	0	Column address	A1–A8	A9	A10	L/H* ¹	A20* ²	A13	A14	A15
				Row address	A9–A16	A17	A18	A19	A20* ²	A21	A22	A23

Table 7.6 SZ and AMX Bits and Address Multiplex Output (cont)

Setting				Output Timing	External Address Pins							
SZ	AMX2	AMX1	AMX0		A1–A8	A9	A10	A11	A12	A13	A14	A15
0	1	0	0	Column address	A1–A8	A9	A10	LH* ¹	A12	A21* ³	A22* ²	A15
				Row address	A9–A16	A17	A18	A19	A20	A21* ³	A22* ²	A23
0	0	1	1	Column address	A1–A8	L/H* ¹	A18* ²	A11	A12	A13	A14	A15
				Row address	A9–A16	A17	A18* ²	A19	A20	A21	A22	A23
0	1	1	1	Column address	A1–A8	L/H* ¹	A17* ²	A11	A12	A13	A14	A15
				Row address	A9–A16	A16	A17* ²	A19	A20	A21	A22	A23

Notes: AMX2–AMX0 setting 110 is reserved and must not be used. When SZ = 0, AMX2–AMX0 settings 001, 010, and 101 are also reserved and must not be used.

*1 L/H is a bit used to specify commands. It is fixed at L or H according to the access mode.

*2 Bank address specification.

*3 Bank address specification when using four banks.

7.5.3 Burst Reads

Figure 7.19 (a) and (b) show the timing charts for burst reads. In the following example, 2 synchronous DRAMs of 256k × 16 bits are connected, the data width is 32 bits and the burst length is 4. After a Tr cycle that performs ACTV command output, a READA command is issued in the Tc cycle, read data is accepted in cycles Td1 to Td4, and the end of the read sequence is waited for in the Tde cycle. One Tde cycle is issued when Iø : Eø ≠ 1 : 1, and two cycles when Iø : Eø = 1 : 1. Tap is a cycle for waiting for the completion of the auto-precharge based on the READA command within the synchronous DRAM. During this period, no new access commands are issued to the same bank. Accesses of the other bank of the synchronous DRAM by another CS space are possible. Depending on the TRP1, TRP0 specification in MCR, the chip determines the number of Tap cycles and does not issue a command to the same bank during that period.

Figure 7.19 (a) and (b) show examples of the basic cycle. Because a slower synchronous DRAM is connected, setting WCR1 and MCR bits can extend the cycle. The number of cycles from the ACTV command output cycle Tr to the READA command output cycle Tc can be specified by bits RCD1 and RCD0 in MCR. 00 specifies 1 cycle, 01 specifies 2 cycles, and 10 specifies 3 cycles. For 2 or 3 cycles, a NOP command issue cycle Trw for the synchronous DRAM is inserted

between the Tr cycle and the Tc cycle. The number of cycles between the READA command output cycle Tc and the initial read data fetch cycle Td1 can be specified between 1 cycle and 4 cycles using the W21/W20 and W31/W30 bits in WCR1. The number of cycles at this time corresponds to the number of CAS latency cycles of the synchronous DRAM. When 2 cycles or more, a NOP command issue cycle Tw is inserted between the Tc cycle and the Td1 cycle. The number of cycles in the precharge completion waiting cycle Tap is specified by bits TRP1 and TRP0 in MCR. When CAS latency is 1, a Tap cycle comprising the number of cycles specified by TRP1 and TRP0 is generated. When the CAS latency is 2 or more, a Tap cycle equal to the TRP specification – 1 is generated. During the Tap cycle, no commands other than NOP are issued to the same bank. Figure 7.20 (a) and (b) show examples of burst read timing when RCD1/RCD0 is 01, W31/W30 is 01, and TRP1/TRP0 is 01.

When the data width is 16 bits, 8 burst cycles are required for a 16-byte data transfer. The data fetch cycle goes from Td1 to Td8.

Synchronous DRAM CAS latency is up to 3 cycles, but the CAS latency of the bus state controller can be specified up to 4. This is so that circuits containing latches can be installed between synchronous DRAMs and the chip.

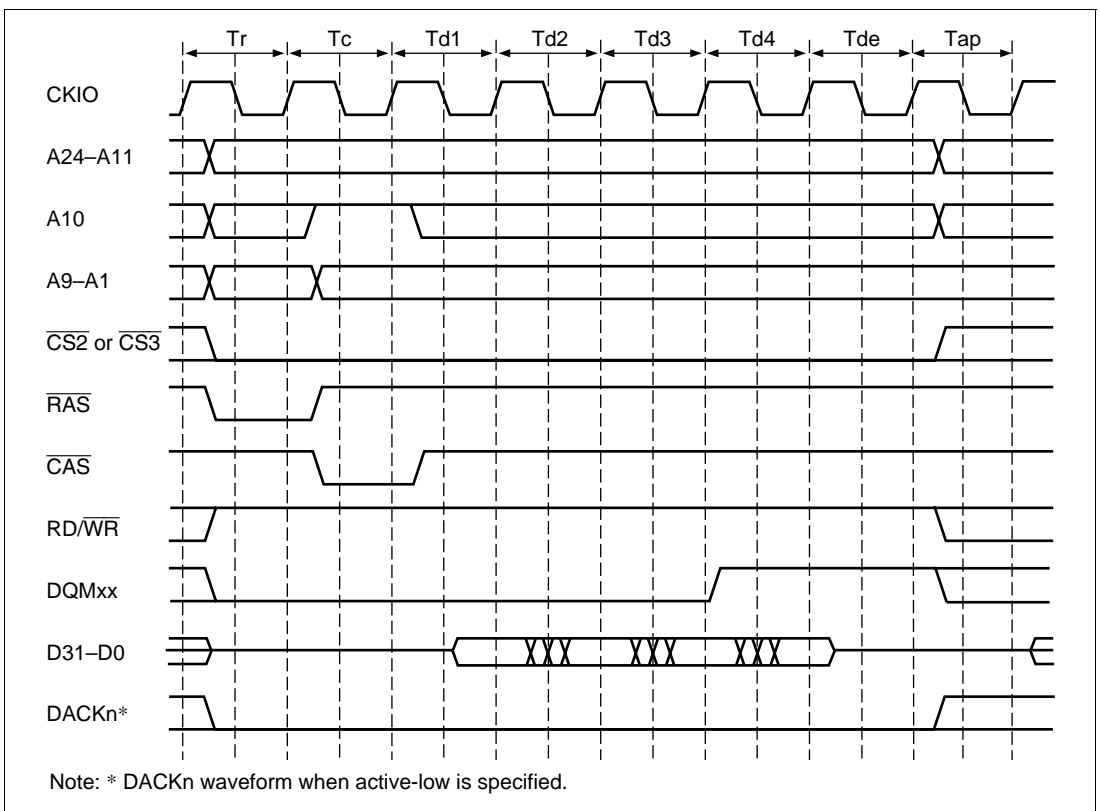

Figure 7.19 (a) Basic Burst Read Timing (Auto-Precharge) $I\phi : E\phi$ other than 1 : 1

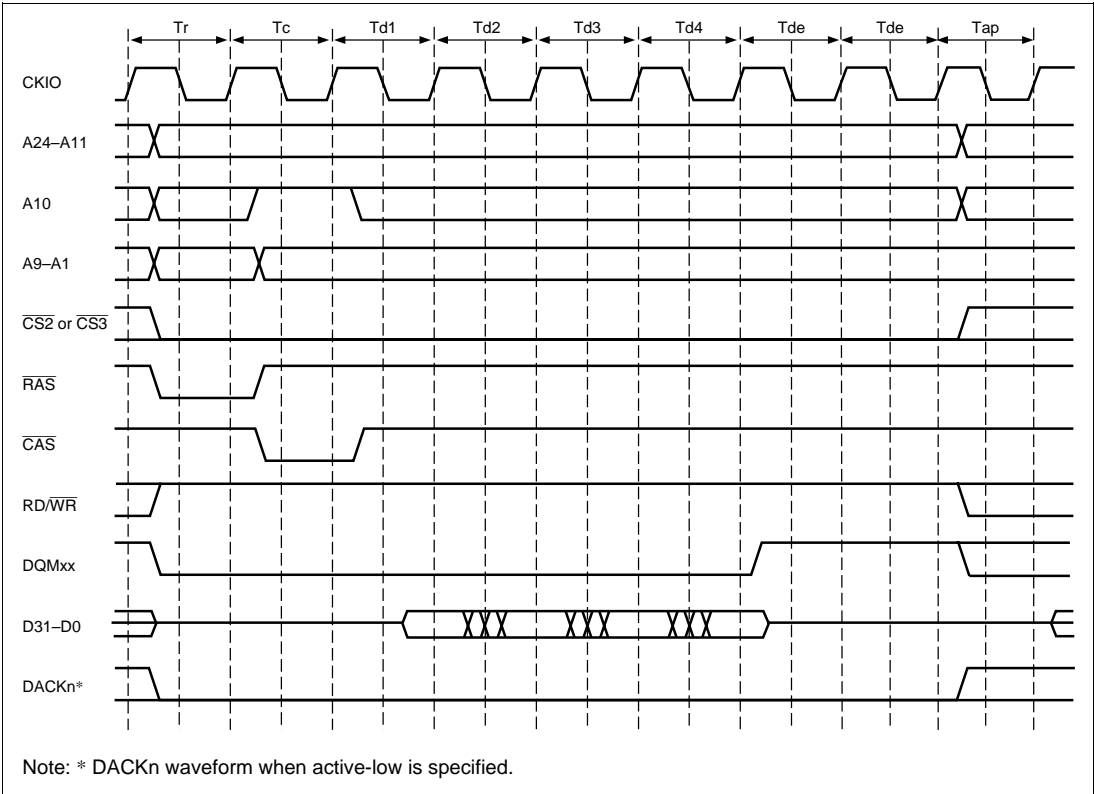
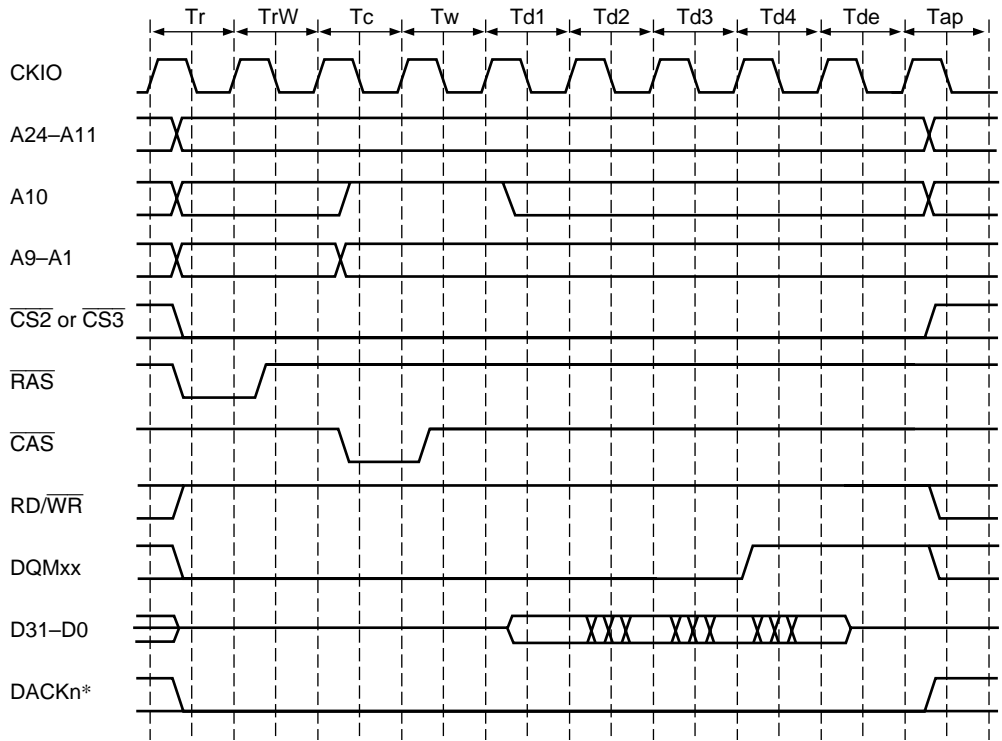

Figure 7.19 (b) Basic Burst Read Timing (Auto-Precharge) I ϕ : E ϕ = 1 : 1



Note: * DACKn waveform when active-low is specified.

Figure 7.20 (a) Burst Read Wait Specification Timing (Auto-Precharge)

$I\phi : E\phi$ other than 1 : 1

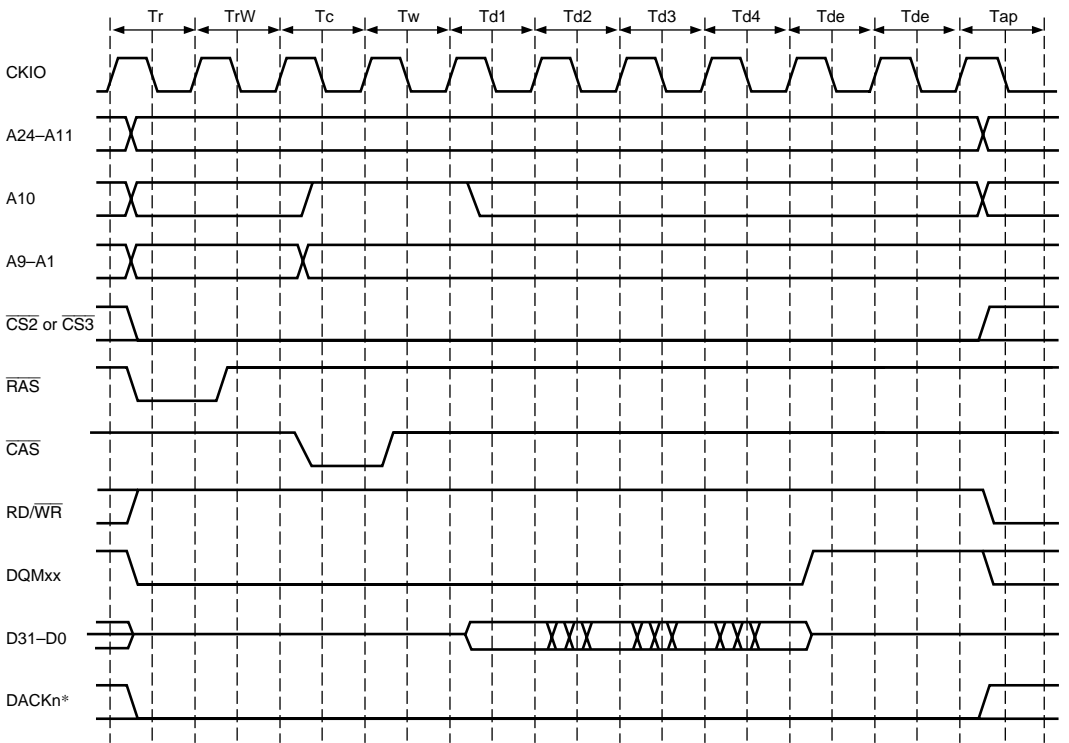

Note: * DACKn waveform when active-low is specified.

Figure 7.20 (b) Burst Read Wait Specification Timing (Auto-Precharge) $I\phi : E\phi = 1 : 1$

7.5.4 Single Reads

When a cache area is accessed and there is a cache miss, the cache fill cycle is performed in 16-byte units. This means that all the data read in the burst read is valid. On the other hand, when a cache-through area is accessed the required data is a maximum length of 32 bits, and the remaining 12 bytes are wasted. The same kind of wasted data access is produced when synchronous DRAM is specified as the source in a DMA transfer by the DMAC and the transfer unit is other than 16 bytes. Figure 7.21 (a) and (b) show the timings of a single address read. Because the synchronous DRAM is set to the burst read mode, the read data output continues after the required data is received. To avoid data conflict, an empty read cycle is performed from Td2 to Td4 after the required data is read in Td1 and the device waits for the end of synchronous DRAM operation.

When the data width is 16 bits, the number of burst transfers during a read is 8. Data is fetched in cache-through and other DMA read cycles only in the Td1 and Td2 cycles (of the 8 cycles from Td1 to Td8) for longword accesses, and only in the Td1 cycle for word or byte accesses.

Empty cycles tend to increase the memory access time, lower the program execution speed, and lower the DMA transfer speed, so it is important to avoid accessing unnecessary cache-through areas and to use data structures that enable 16-byte unit transfers by placing data on 16-byte boundaries when performing DMA transfers that specify synchronous DRAM as the source.

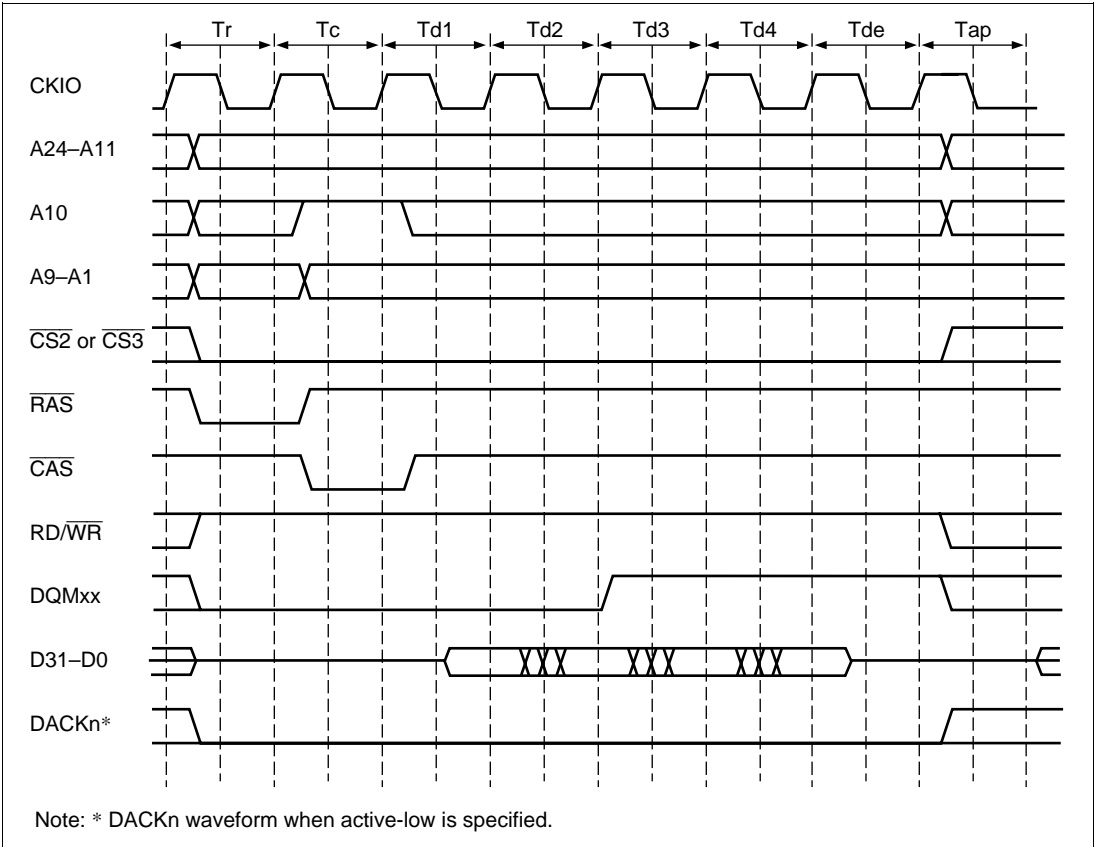

Figure 7.21 (a) Single Read Timing (Auto-Precharge) Iφ : Eφ other than 1 : 1

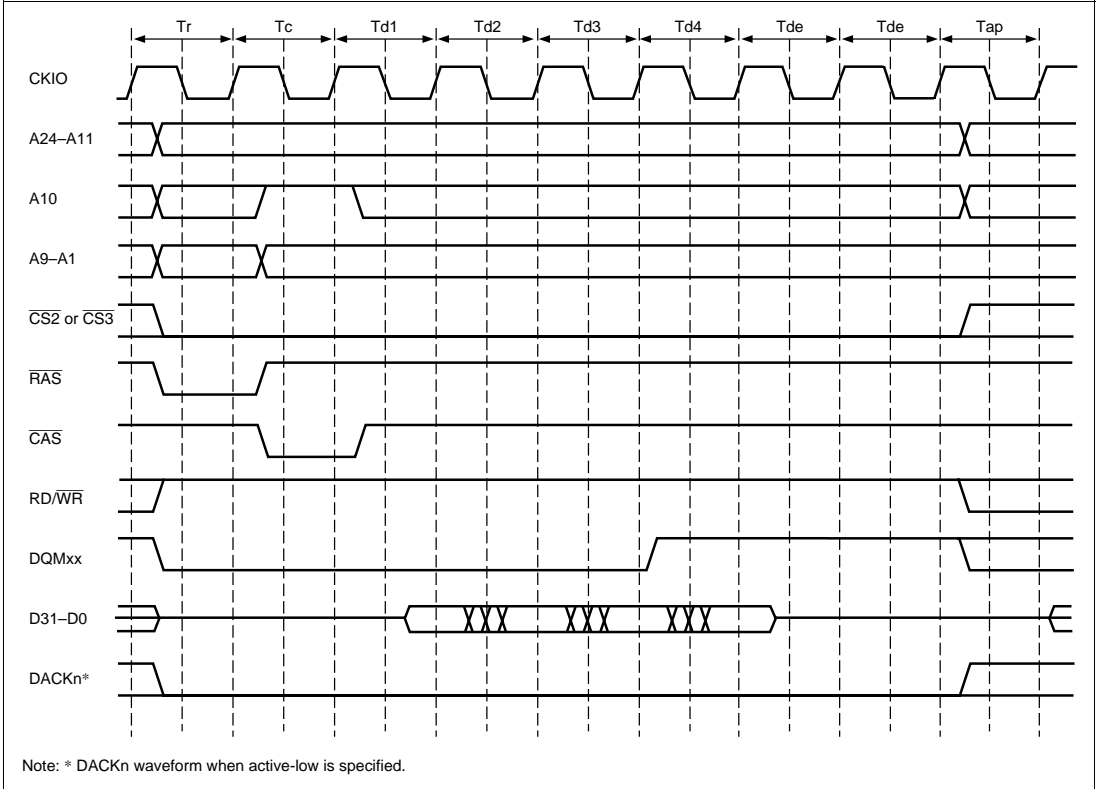
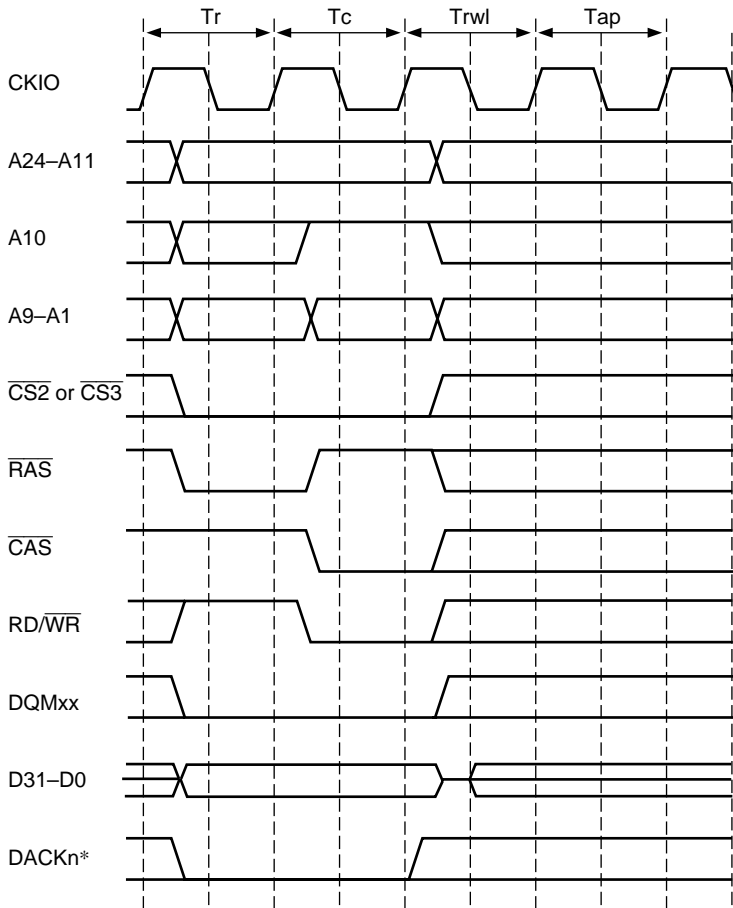

Figure 7.21 (b) Single Read Timing (Auto-Precharge) Iφ : Eφ = 1 : 1

7.5.5 Single Writes

Synchronous DRAM writes are executed as single writes or burst writes according to the specification by the BWE bit in BCR3. Figure 7.22 shows the basic timing chart for single write accesses. After the ACTV command Tr, a WRITA command is issued in Tc to perform an auto-precharge. In the write cycle, the write data is output simultaneously with the write command. When writing with an auto-precharge, the bank is precharged after the completion of the write command within the synchronous DRAM, so no command can be issued to that bank until the precharge is completed. For that reason, besides a Tap cycle to wait for the precharge during read accesses, a Trw1 cycle is added to wait until the precharge is started, and the issuing of any new commands to the same bank is delayed during this period. The number of cycles in the Trw1 cycle can be specified using the TRWL1 and TRWL0 bits in MCR.



Note: * DACKn waveform when active-low is specified.

Figure 7.22 Basic Single Write Cycle Timing (Auto-Precharge)

7.5.6 Burst Write Mode

Burst write mode can be selected by setting the BWE bit to 1 in BCR3. The basic timing charts for burst write access is shown in figure 7.23 (a) and (b). This example assumes a 32-bit bus width and a burst length of 4. In the burst write cycle, the WRITA command that performs auto-precharge is issued in T_{c1} following the ACTV command T_r cycle. The first 4 bytes of write data are output simultaneously with the WRITA command in T_{c1} , and the remaining 12 bytes of data are output consecutively in T_{c2} , T_{c3} , and T_{c4} . In a write with auto-precharge, as with a single write, a T_{rw1} cycle that provides the waiting time until precharge is started is inserted after output of the write data, followed by a T_{ap} cycle for the precharge wait in a write access. The T_{rw1} and T_{ap} cycles can be set respectively in MCR by bits TRWL1 and TRWL0, and bits TRP1 and TRP0.

When a single write is performed in burst write mode, the synchronous DRAM setting is for a burst length of 4. After data is written in Tc1, empty writes are performed in Tc2, Tc3, and Tc4 by driving the DQMxx signal high.

These empty cycles increase the memory access time and tend to reduce program execution speed and DMA transfer speed. Therefore, unnecessary cache-through area accesses should be avoided, and copy-back should be selected for the cache setting. Also, in DMA transfer, it is important to use a data structure that allows transfer in 16-bit units.

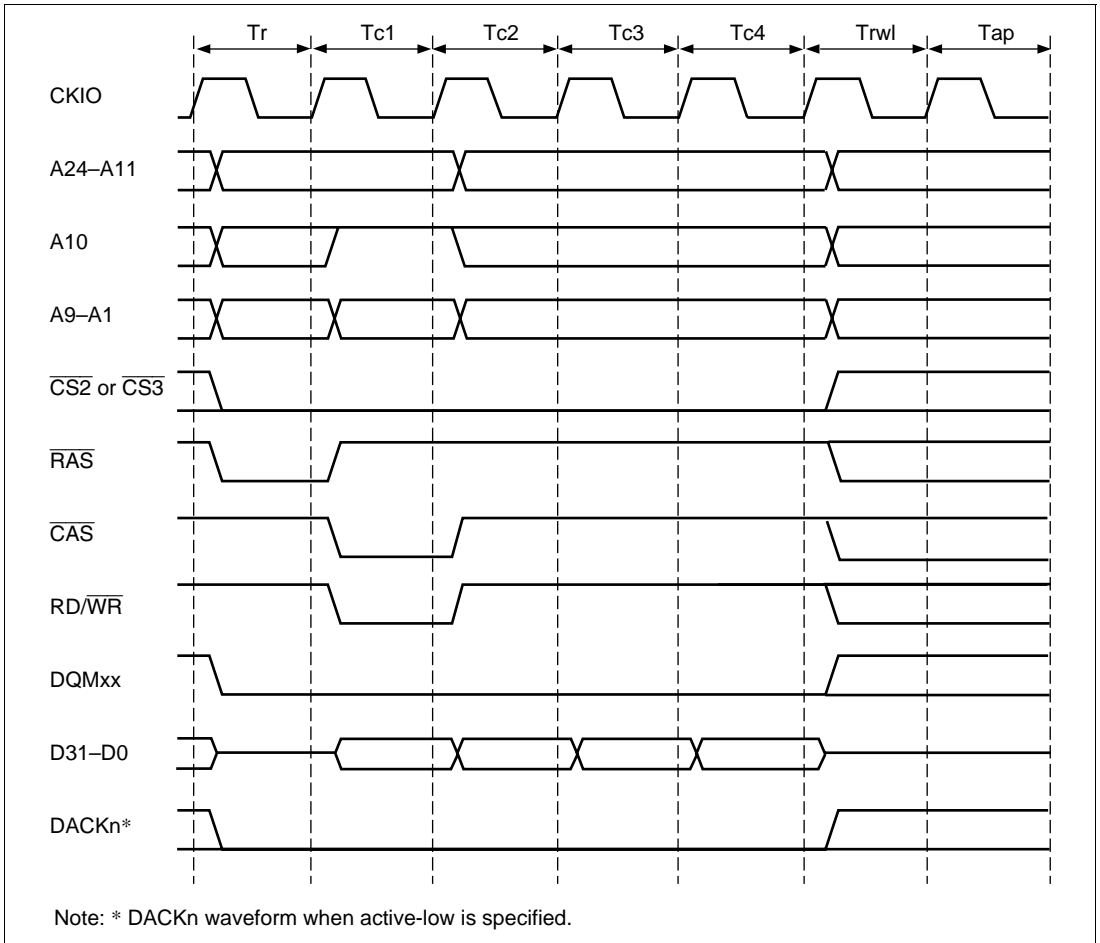
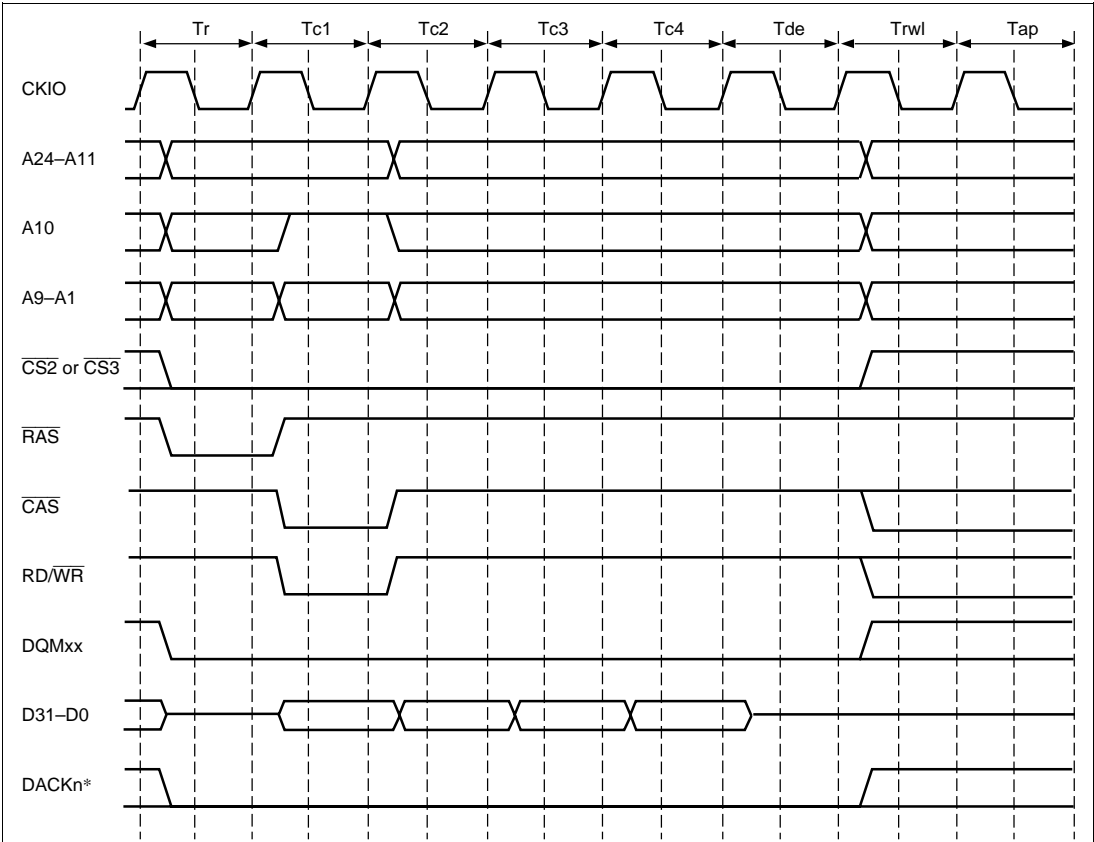

Figure 7.23 (a) Basic Burst Write Timing (Auto-Precharge) $I\phi : E\phi$ other than 1 : 1



Note: * DACKn waveform when active-low is specified.

Figure 7.23 (b) Basic Burst Write Timing (Auto-Precharge) Iφ : Eφ = 1 : 1

7.5.7 Bank Active Function

A synchronous DRAM bank function is used to support high-speed accesses of the same row address. When the RASD bit in MCR is set to 1, read/write accesses are performed using commands without auto-precharge (READ, WRIT). In this case, even when the access is completed, no precharge is performed. This function is not supported in the CS2 space. When the bank active function is used, no precharge is performed when the access is completed. When accessing the same row address in the same bank, a READ or WRIT command can be called immediately without calling an ACTV command, just like the $\overline{\text{RAS}}$ down mode of the DRAM's high-speed page mode. Synchronous DRAM is divided into two banks, so one row address in each can stay active. When the next access is to a different row address, a PRE command is called first to precharge the bank, and access is performed by an ACTV command and READ or WRIT command in order, after the precharge is completed. With successive accesses to different row addresses, the precharge is performed after the access request occurs, so the access time is longer. When writing, performing an auto-precharge means that no command can be called for tRWL + tAP cycles after a WRITA command is called. When the bank active mode is used, READ or WRIT commands can be issued consecutively if the row address is the same. This shortens the number of cycles by tRWL + tAP for each write. The number of cycles between the issue of the precharge command and the row address strobe command is determined by the TRP1, TRP0 in MCR.

Whether execution is faster when the bank active mode is used or when basic access is used is determined by the proportion of accesses to the same row address (P1) and the average number of cycles from the end of one access to the next access (tA). When tA is longer than tAP, the delay waiting for the precharge during a read becomes invisible. If tA is longer than tRWL + tAP, the delay waiting for the precharge also becomes invisible during writes. The difference between the bank active mode and basic access speeds in these cases is the number of cycles between the start of access and the issue of the read/write command: $(\text{TRP} + \text{tRCD}) \times (1 - \text{P1})$ and tRCD, respectively.

The time that a bank can be kept active, tRAS, is limited. When the period will be provided by program execution, and it is not assured that another row address will be accessed without a hit to the cache, the synchronous DRAM must be set to auto-refresh and the refresh cycle must be set to the maximum value tRAS or less. This enables the limit on the maximum active period for each bank to be ensured. When auto-refresh is not being used, some measure must be taken in the program to ensure that the bank does not stay active for longer than the prescribed period.

Figure 7.24 (a) and (b) show burst read cycles that is not an auto-precharge cycle, figure 7.25 (a) and (b) show burst read cycles to a same row address, figure 7.26 (a) and (b) show burst read cycles to different row addresses, figure 7.27 shows a write cycle without auto-precharge, figure 7.28 shows a write cycle to a same row address, and figure 7.29 shows a write cycle to different row addresses.

In figure 7.25, a cycle that does nothing, T_{nop} , is inserted before the T_c cycle that issues the READ command. Synchronous DRAMs have a 2 cycle latency during reads for the DQM_{xx} signals that specify bytes. If the T_c cycle is performed immediately without inserting a T_{nop} cycle, the DQM_{xx} signal for the T_{d1} cycle data output cannot be specified. This is why the T_{nop} cycle is inserted. When the CAS latency is 2 or more, however, the T_{nop} cycle is not inserted so that timing requirements will be met even when a DQM_{xx} signal is set after the T_c cycle.

When the bank active mode is set, the access will start with figure 7.24 or figure 7.27 and repeat figure 7.25 or figure 7.28 for as long as the same row address continues to be accessed when only accesses to the respective banks of the CS3 space are considered. Accesses to other CS spaces during this period do not affect this operation. When an access occurs to a different row address while the bank is active, figure 7.26 or figure 7.29 will be substituted for figures 7.25 and 7.28 after this is detected. Both banks will become inactive even in the bank active mode after the refresh cycle ends or after the bus is released by bus arbitration.

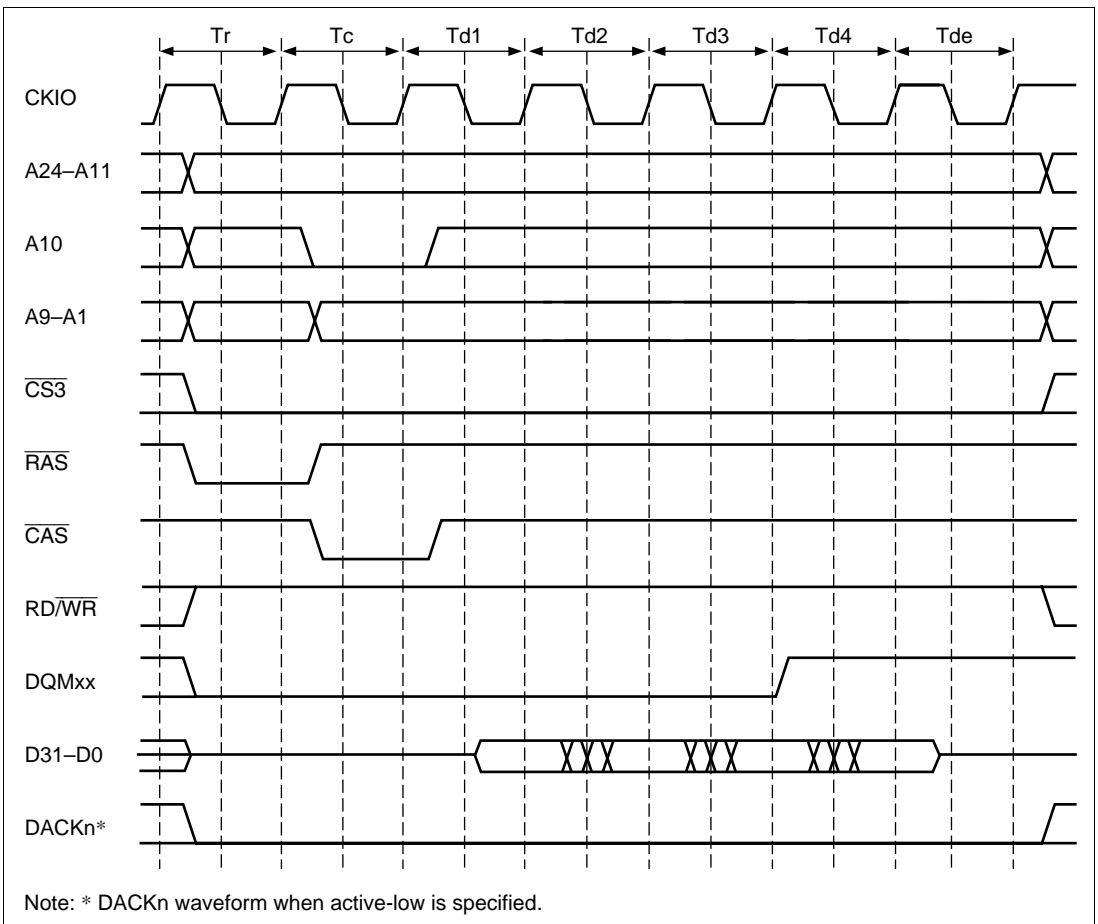
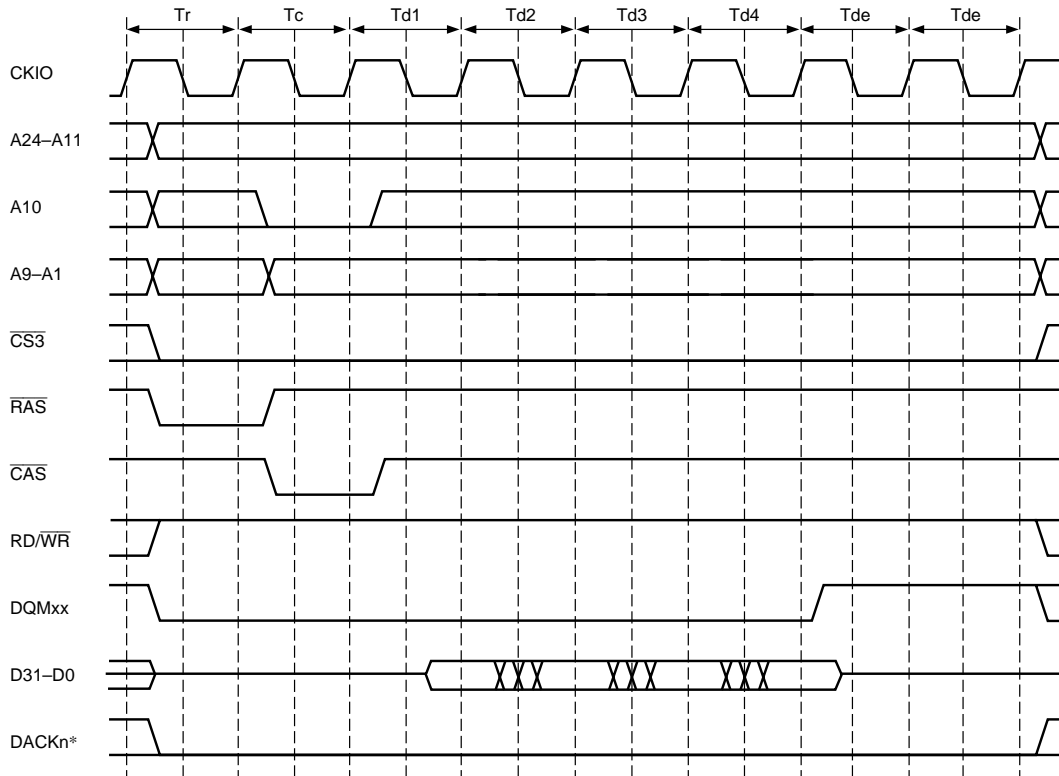

Figure 7.24 (a) Burst Read Timing (No Precharge) $I\phi : E\phi$ other than 1 : 1



Note: * DACKn waveform when active-low is specified.

Figure 7.24 (b) Burst Read Timing (No Precharge) $I\phi : E\phi = 1 : 1$

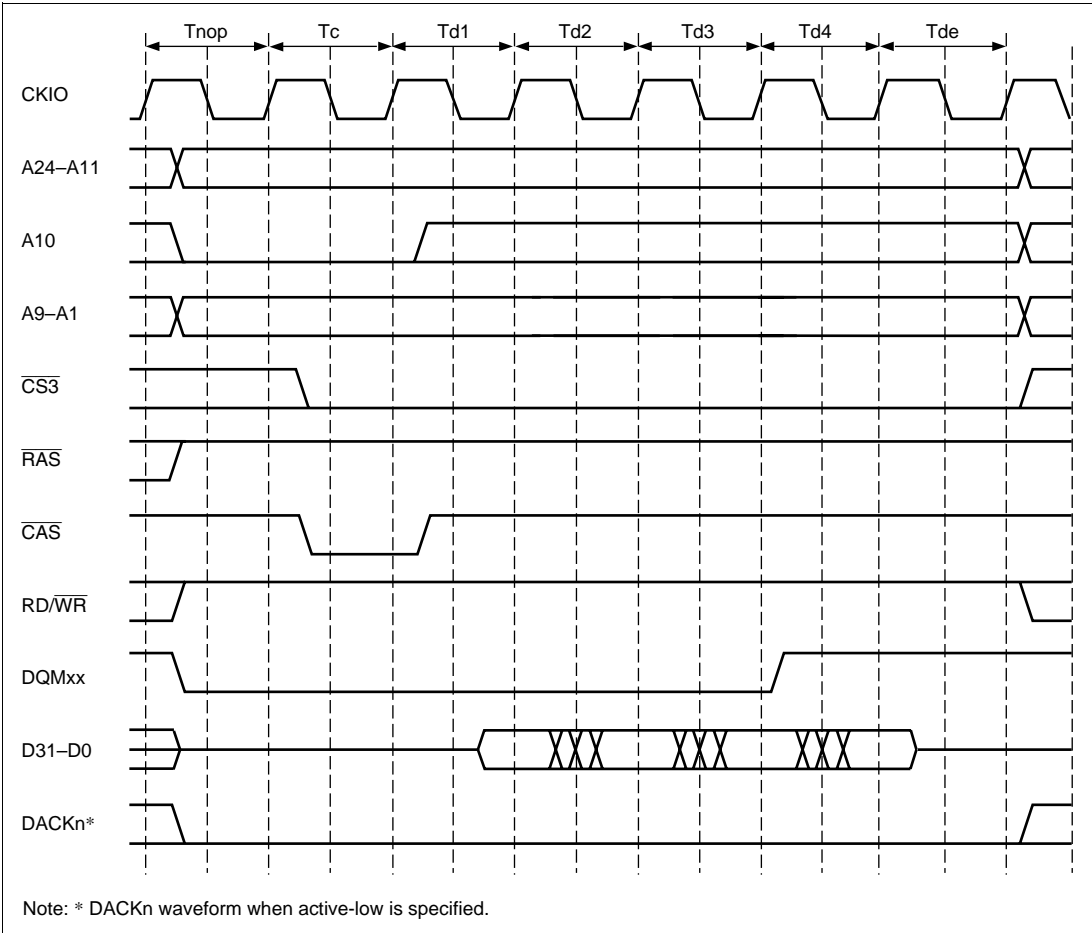

Figure 7.25 (a) Burst Read Timing (Bank Active, Same Row Address)
 $I\phi : E\phi$ other than 1 : 1

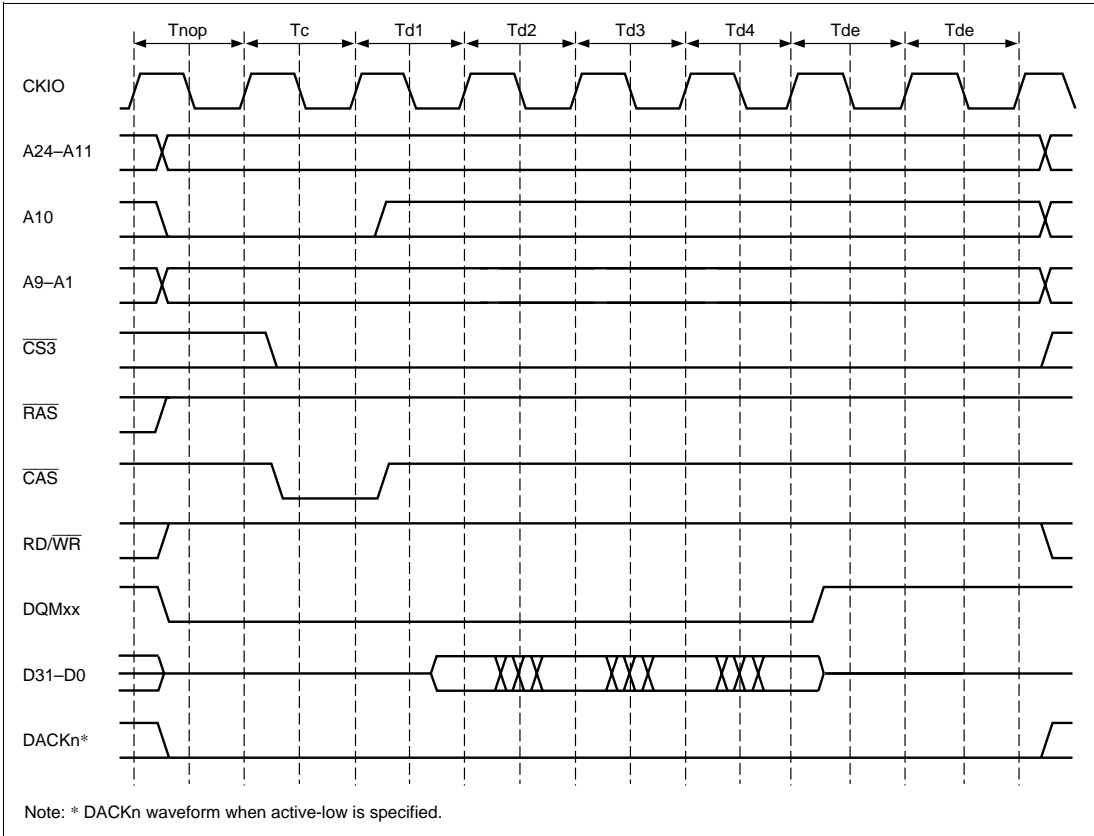

Figure 7.25 (b) Burst Read Timing (Bank Active, Same Row Address) $I\phi : E\phi = 1 : 1$

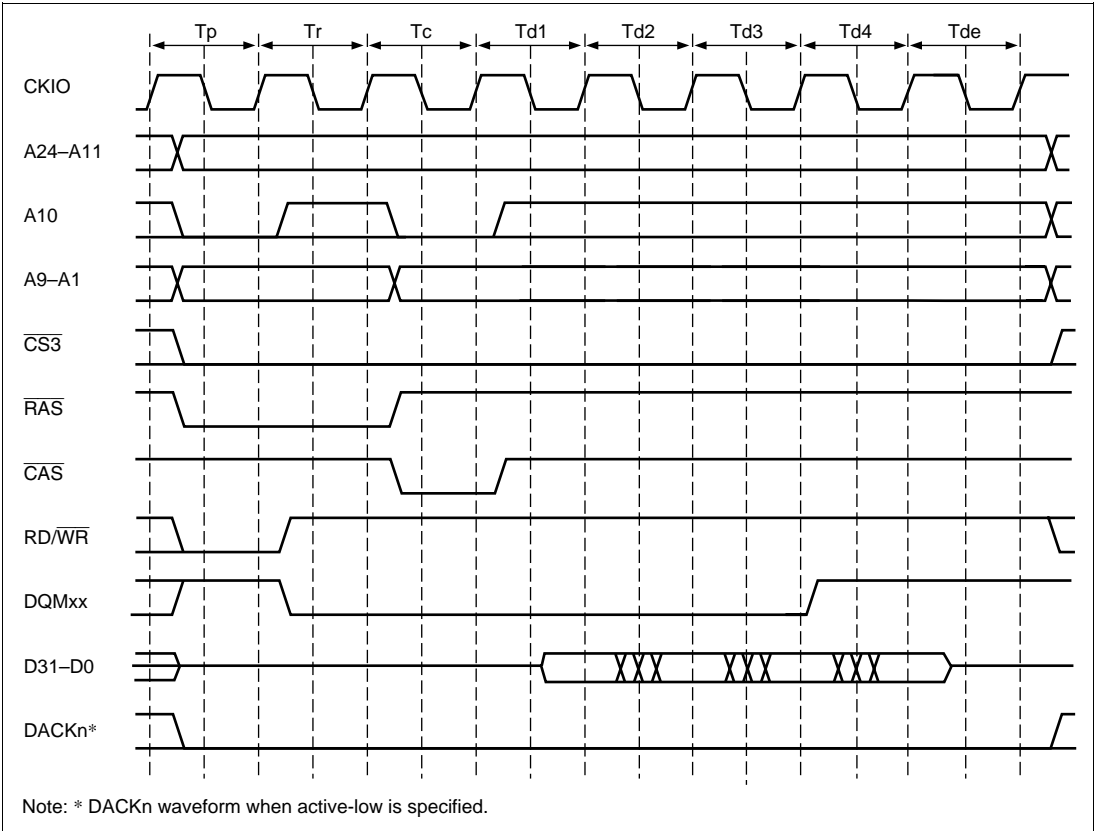
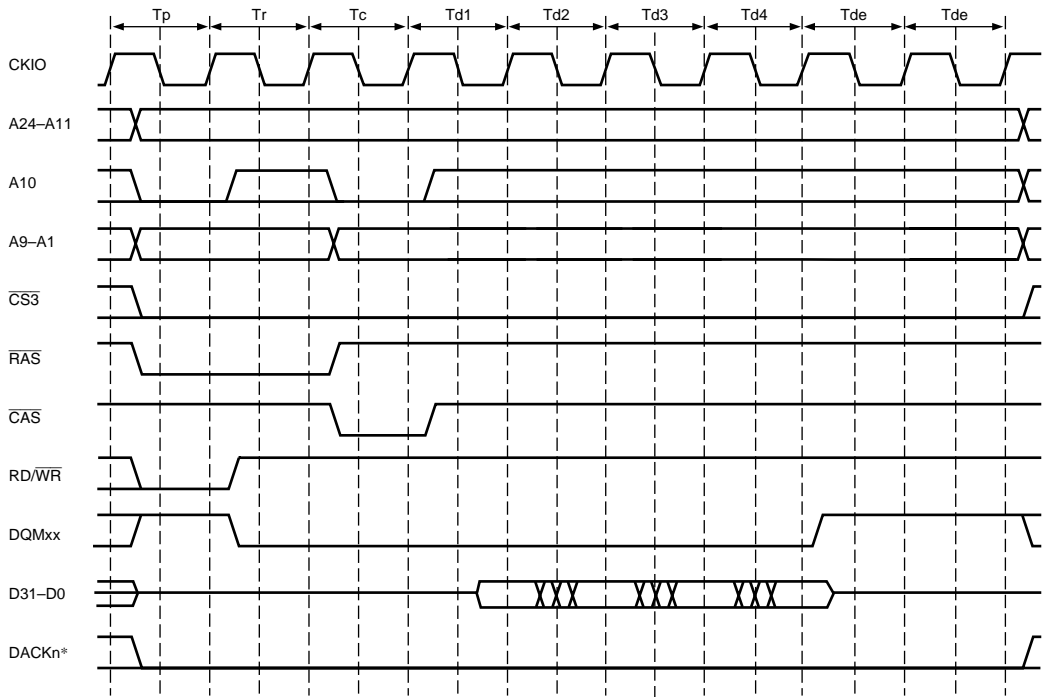
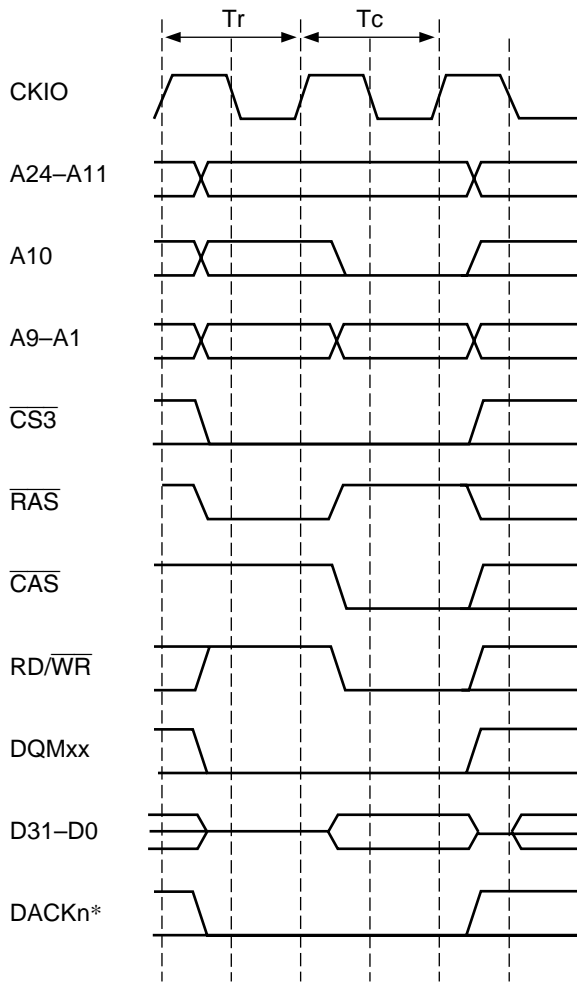

Figure 7.26 (a) Burst Read Timing (Bank Active, Different Row Addresses)
 $I\phi : E\phi$ other than 1 : 1



Note: * DACKn waveform when active-low is specified.

Figure 7.26 (b) Burst Read Timing (Bank Active, Different Row Addresses) I ϕ : E ϕ = 1 : 1



Note: * DACKn waveform when active-low is specified.

Figure 7.27 Single Write Mode Timing (No Precharge)

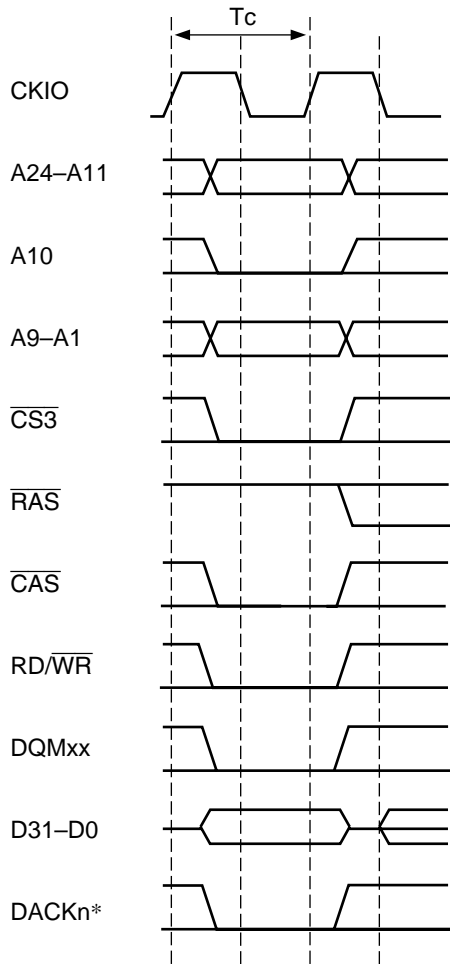

Note: * DACKn waveform when active-low is specified.

Figure 7.28 Single Write Mode Timing (Bank Active, Same Row Address)

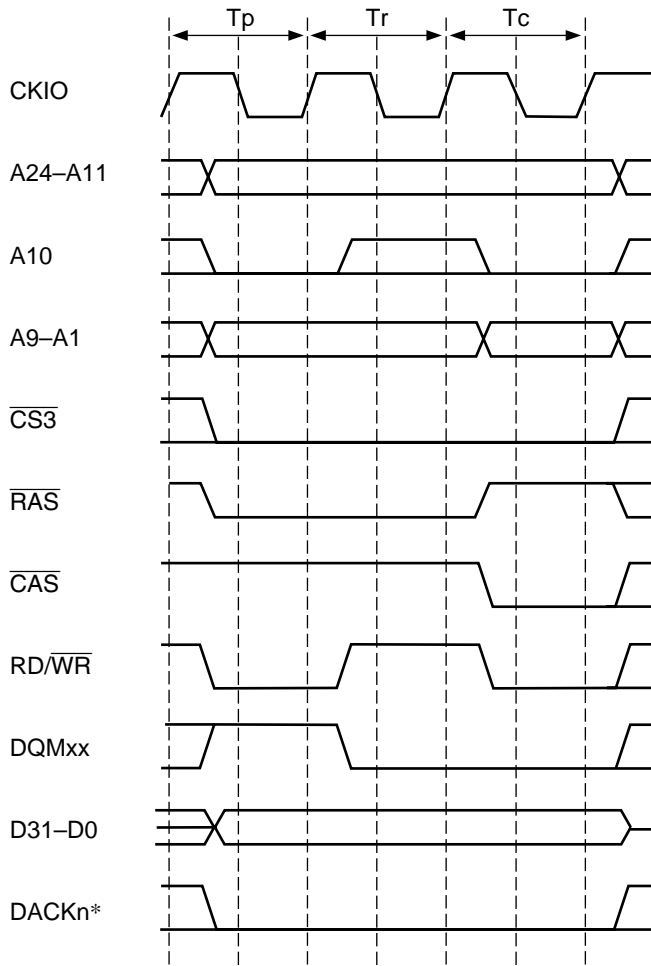

Note: * $DACK_n$ waveform when active-low is specified.

Figure 7.29 Single Write Mode Timing (Bank Active, Different Row Addresses)

7.5.8 Refreshes

The bus state controller is equipped with a function to control refreshes of synchronous DRAM. Auto-refreshes can be performed by setting the RMODE bit to 0 and the RFSH bit to 1 in MCR. Consecutive refreshes can also be generated by setting the RRC2–RRC0 bits in RTCSR. When the synchronous DRAM is not accessed for a long period of time, set the RFSH bit and RMODE bit both to 1 to generate self-refresh mode, which uses low power consumption to retain data.

Auto-Refresh: The number of refreshes set in the RRC2–RRC0 bits in RTCSR are performed at the interval determined by the input clock selected by the CKS2–CKS0 bits in RTCSR and the value set in RTCOR. Set the CKS2–CKS0 bits and RTCOR so that the refresh interval specifications of the synchronous DRAM being used are satisfied. First, set RTCOR, RTCNT, and the RMODE and RFSH bits in MCR, then set the CKS2–CKS0 and RRC2–RRC0 bits in RTCSR. When a clock is selected with the CKS2–CKS0 bits, RTCNT starts counting up from the value at that time. The RTCNT value is constantly compared to the RTCOR value, and when the two values match, a refresh request is made, and the number of auto-refreshes set in RRC2–RRC0 are performed. RTCNT is cleared to 0 at that time and the count up starts again. Figure 7.30 shows the timing for the auto-refresh cycle.

First, a PALL command is issued during the T_p cycle to change all the banks from active to precharge states. Then number of idle cycles equal to one less than the value set in TRP1 and TRP0 are inserted, and a REF command is issued in the T_{rr} cycle. After the T_{rr} cycle, no new commands are output for the number of cycles specified in the TRAS bit in MCR. The TRAS bit must be set to satisfy the refresh cycle time specifications (active/active command delay time) of the synchronous DRAM. When the set value of the TRP1 and TRP0 bits in MCR is 2 or more, an NOP cycle is inserted between the T_p cycle and T_{rr} cycle.

During a manual reset, no refresh request is issued, since there is no RTCNT count-up. To perform a refresh properly, make the manual reset period shorter than the refresh cycle interval and set RTCNT to $(RTCOR - 1)$ so that the refresh is performed immediately after the manual reset is cleared.

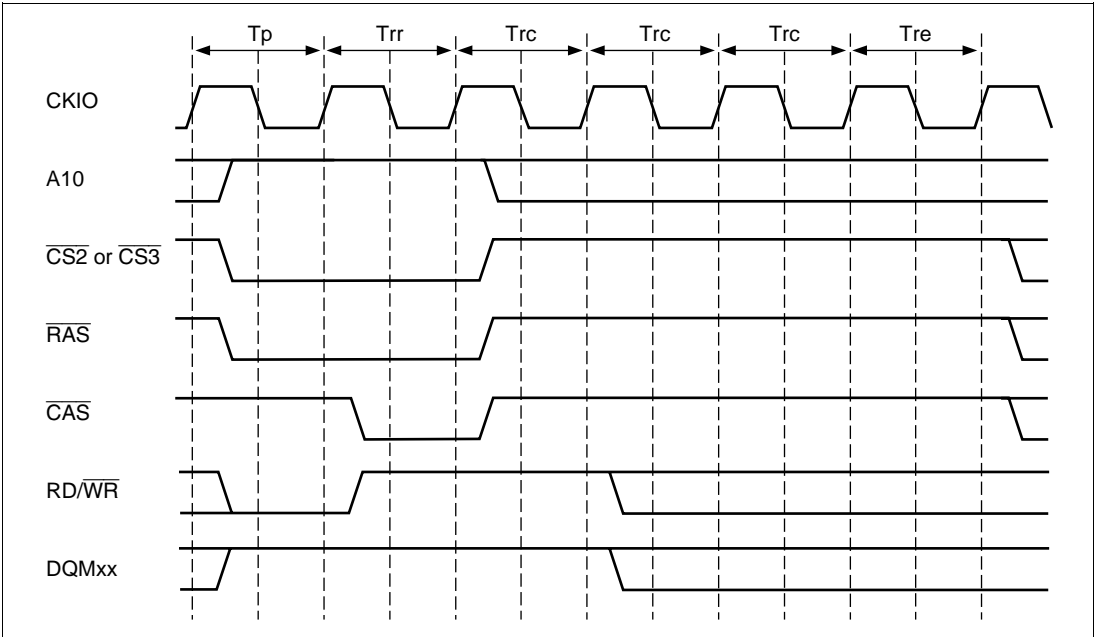

Figure 7.30 Auto-Refresh Timing

Self-Refreshes: The self-refresh mode is a type of standby mode that produces refresh timing and refresh addresses within the synchronous DRAM. It is started up by setting the RMODE and RFSH bits to 1. The synchronous DRAM is in self-refresh mode when the CKE signal level is low. During the self-refresh, the synchronous DRAM cannot be accessed. To clear the self-refresh, set the RMODE bit to 0. After self-refresh mode is cleared, issuing of commands is prohibited for the number of cycles specified in the TRAS1 and TRAS0 bits in MCR. Figure 7.31 shows the self-refresh timing. Settings must be made so that self-refresh clearing and data retention are performed correctly, and auto-refreshing is performed without delay at the correct intervals. When self-refresh mode is entered while the synchronous DRAM is set for auto-refresh or when leaving the standby mode with a manual reset or NMI, auto-refresh can be re-started if RFSH is 1 and RMODE is 0 when the self-refresh mode is cleared. When time is required between clearing the self-refresh mode and starting the auto-refresh mode, this time must be reflected in the initial RTCNT setting. When the RTCNT value is set to RTCOR – 1, the refresh can be started immediately.

If the standby function of the chip is used to enter the standby mode after the self-refresh mode is set, the self-refresh state continues; the self-refresh state will also be maintained after returning from a standby using an NMI. A manual reset cannot be used to exit the self-refresh state either.

During a power-on reset, the bus state controller register is initialized, so the self-refresh state is ended.

Refresh Requests and Bus Cycle Requests: When a refresh request occurs while a bus cycle is executing, the refresh will not be executed until the bus cycle is completed. When a refresh request occurs while the bus is released using the bus arbitration function, the refresh will not be executed until the bus is recaptured. In the SH7616, the REFOUT pin is provided to send a signal requesting the bus right during the wait for refreshing to be executed. REFOUT is asserted until the bus is acquired. If RTCNT and RTCOR match and a new refresh request occurs while waiting for the refresh to execute, the previous refresh request is erased. To make sure the refresh executes properly, be sure that the bus cycle and bus capture do not exceed the refresh interval.

If a bus arbitration request occurs during a self-refresh, the bus is not released until the self-refresh is cleared.

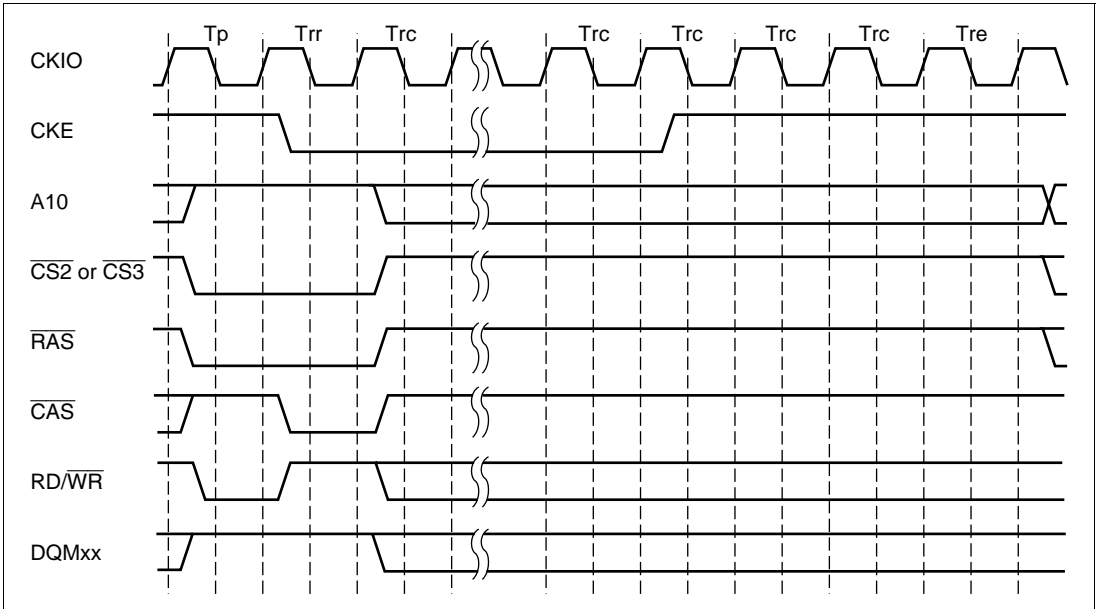

Figure 7.31 Self-Refresh Timing

7.5.9 Overlap Between Auto Precharge Cycle (Tap) and Next Access

If the CPU and DMAC or E-DMAC are accessed sequentially and the first access is to SDRAM and also in the auto precharge mode, the auto precharge cycle (Tap) of the first access may overlap the second access if the second access is to a different memory space or to a different bank of the same SDRAM. (Even if the second access is to the normal space, there may be an overlap with the Tap cycle.) For this reason, it appears for the number of cycles of the second access as if access takes place sooner (by the number of Tap cycles) than it actually does. Specific cases in which an overlap occurs are listed in table 7.7. Also, figure 7.32 shows is a conceptual diagram of an overlap that occurs when memory spaces CS2 and CS3 are connected to SDRAM (table 7.7, No. 3).

Table 7.7 Cases of Overlap Between Tap Cycle and Next Access

No.	First Access	Second Access
1	Space CS3, auto precharge mode	Access to different space among CS0, CS1, CS2, and CS3
2		Access to different bank in CS3
3	Space CS2, auto precharge mode	Access to different space among CS0, CS1, CS2, and CS3
4		Access to different bank in CS2

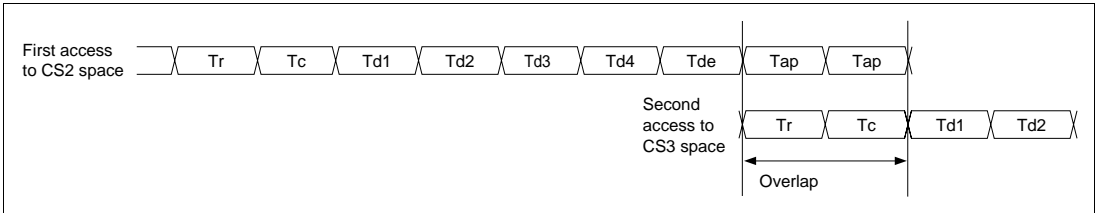

Figure 7.32 Conceptual Diagram of Overlap (Conditions: SDRAM Connected to CS2 Space ($\overline{\text{RAS}}$ Precharge Time Set to 2 Cycles) and SDRAM Connected to CS3 Space)

7.5.10 Power-On Sequence

To use synchronous DRAM, the mode must first be set after the power is turned on. To properly initialize the synchronous DRAM, the synchronous DRAM mode register must be written to after the registers of the bus state controller have first been set. The synchronous DRAM mode register is set using a combination of the $\overline{CS2}$ or $\overline{CS3}$ signal and the \overline{RAS} , $\overline{CAS/OE}$, and $\overline{RD/\overline{WR}}$ signals. They fetch the value of the address signal at that time. If the value to be set is X, the bus state controller operates by writing to address X + H'FFFF0000 or X + H'FFFF8000 from the CPU, which allows the value X to be written to the synchronous DRAM mode register. Whether X + H'FFFF0000 or X + H'FFFF8000 is used depends on the specifications of the synchronous DRAM. Use a value in the range H'000 to H'FFF for X. Data is ignored at this time, but the mode is written using word as the size.

Write any data in word size to the following addresses to select the burst read single write supported by the chip, a CAS latency of 1 to 3, a sequential wrap type, and a burst length of 8 or 4 (depending on whether the width is 16 bits or 32 bits).

- Burst Read/Single Write

For 16 bits:	CAS latency 1	H'FFFF0426	(H'FFFF8426)
	CAS latency 2	H'FFFF0446	(H'FFFF8446)
	CAS latency 3	H'FFFF0466	(H'FFFF8466)
For 32 bits:	CAS latency 1	H'FFFF0848	(H'FFFF8848)
	CAS latency 2	H'FFFF0888	(H'FFFF8888)
	CAS latency 3	H'FFFF08C8	(H'FFFF88C8)

To set burst read, burst write, CAS latency 1 to 3, wrap-type sequential, and burst length 8 or 4 (depending on whether the width is 16 bits or 32 bits), arbitrary data is written to the following addresses, using the word size.

- Burst Read/Burst Write

16-bit width:	CAS latency 1	H'FFFF0026	(H'FFFF8026)
	CAS latency 2	H'FFFF0046	(H'FFFF8046)
	CAS latency 3	H'FFFF0066	(H'FFFF8066)
32-bit width:	CAS latency 1	H'FFFF0048	(H'FFFF8048)
	CAS latency 2	H'FFFF0088	(H'FFFF8088)
	CAS latency 3	H'FFFF00C8	(H'FFFF80C8)

Figure 7.33 shows the mode register setting timing.

Writing to address X + H'FFFF0000 or X + H'FFFF8000 first issues an all-bank precharge command (PALL), then issues eight dummy auto-refresh commands (REF) required for the synchronous DRAM power-on sequence. Lastly, a mode register write command (MRS) is issued. Three idle cycles are inserted between the all-bank precharge command and the first auto-refresh

command, and eight idle cycles between auto-refresh commands, and between the eighth auto-refresh command and the mode register write command, regardless of the MCR setting.

After writing to the synchronous DRAM mode register, perform a dummy read to each synchronous DRAM bank before starting normal access. This will initialize the SH7616's internal address comparator.

Synchronous DRAM requires a fixed idle time after powering on before the all-bank precharge command is issued. Refer to the synchronous DRAM manual for the necessary idle time. When the pulse width of the reset signal is longer than the idle time, the mode register may be set immediately without problem. However, care is required if the pulse width of the reset signal is shorter than the idle time.

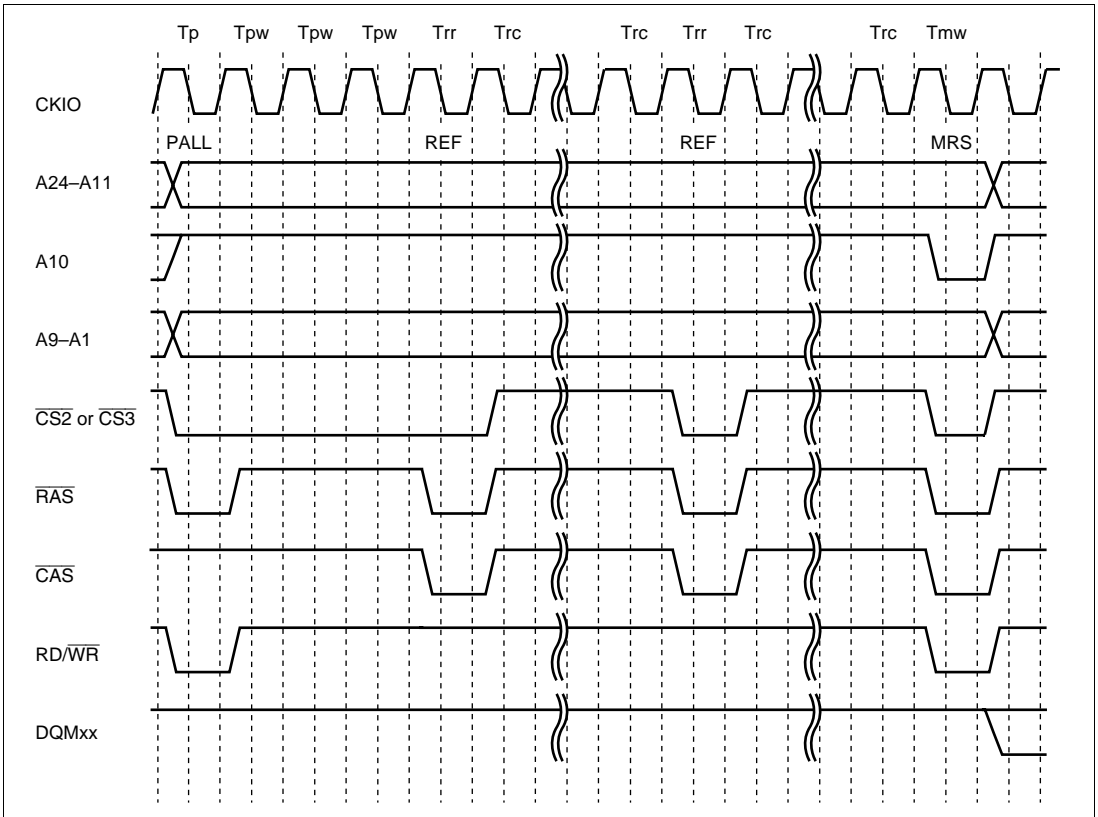

Figure 7.33 Synchronous DRAM Mode Write Timing

7.5.11 64 Mbit Synchronous DRAM (2 Mword × 32-bit) Connection

64 Mbit Synchronous DRAM (× 32-bit) Connection Example: Figure 7.34 shows an example connection between the SH7616 and 64 Mbit synchronous DRAM (× 32-bit).

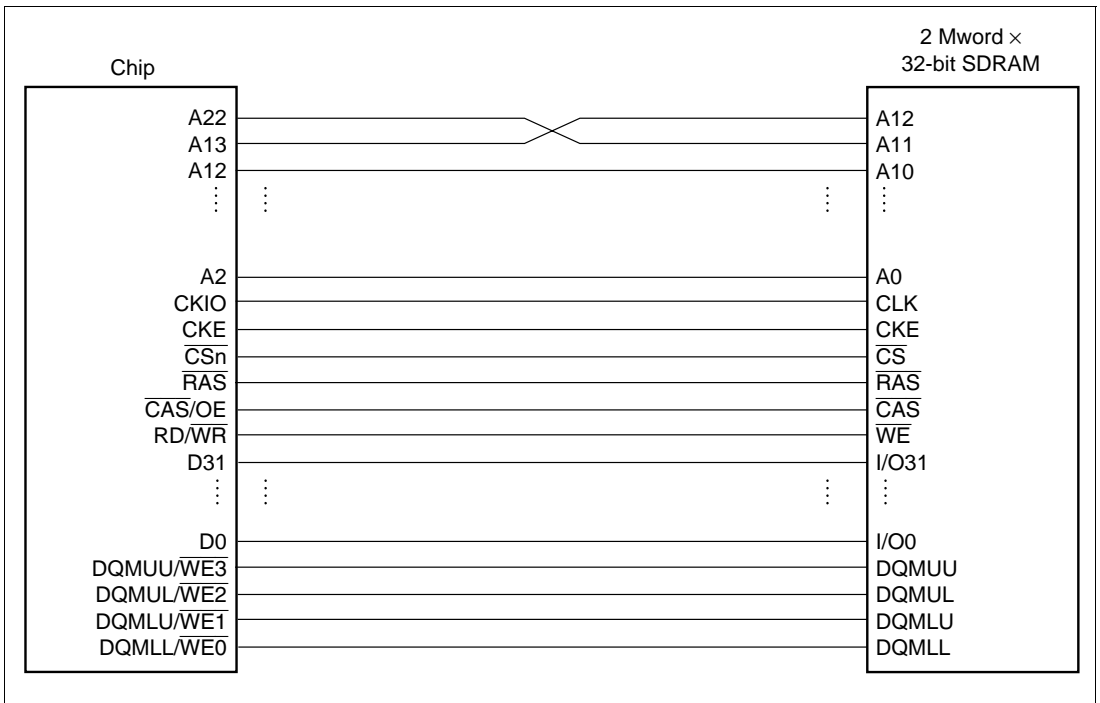

Figure 7.34 64 Mbit Synchronous DRAM (2 Mword × 32-bit) Connection Example

Bus Status Controller (BSC) Register Settings: Set the individual bits in the memory control register (MCR) as follows.

MCR (bit 6) SZ = 1

MCR (bit 7) AMX2 = 0

MCR (bit 5) AMX1 = 0

MCR (bit 4) AMX0 = 0

Synchronous DRAM Mode Settings: To make mode settings for the synchronous DRAM, write to address X+H'FFBF0000 or X+H'FFBF8000 from the CPU.. (X represents the setting value.)

Whether to use X+H'FFBF0000 or X+H'FFBF8000 determines on the synchronous DRAM used.

7.6 DRAM Interface

7.6.1 DRAM Direct Connection

When the DRAM and other memory enable bits (DRAM2–DRAM0) in BCR1 are set to 010, the CS3 space becomes DRAM space, and a DRAM interface function can be used to directly connect DRAM.

The data width of an interface can be 16 or 32 bits (figures 7.35 and 7.36). Two-CAS 16-bit DRAMs can be connected, since $\overline{\text{CAS}}$ is used to control byte access. The $\overline{\text{RAS}}$, $\overline{\text{CAS3}}\text{--}\overline{\text{CAS0}}$, and $\text{RD}/\overline{\text{WR}}$ signals are used to connect the DRAM. When the data width is 16 bits, $\overline{\text{CAS3}}$, and $\overline{\text{CAS2}}$ are not used. In addition to ordinary read and write access, burst access using high-speed page mode is also supported.

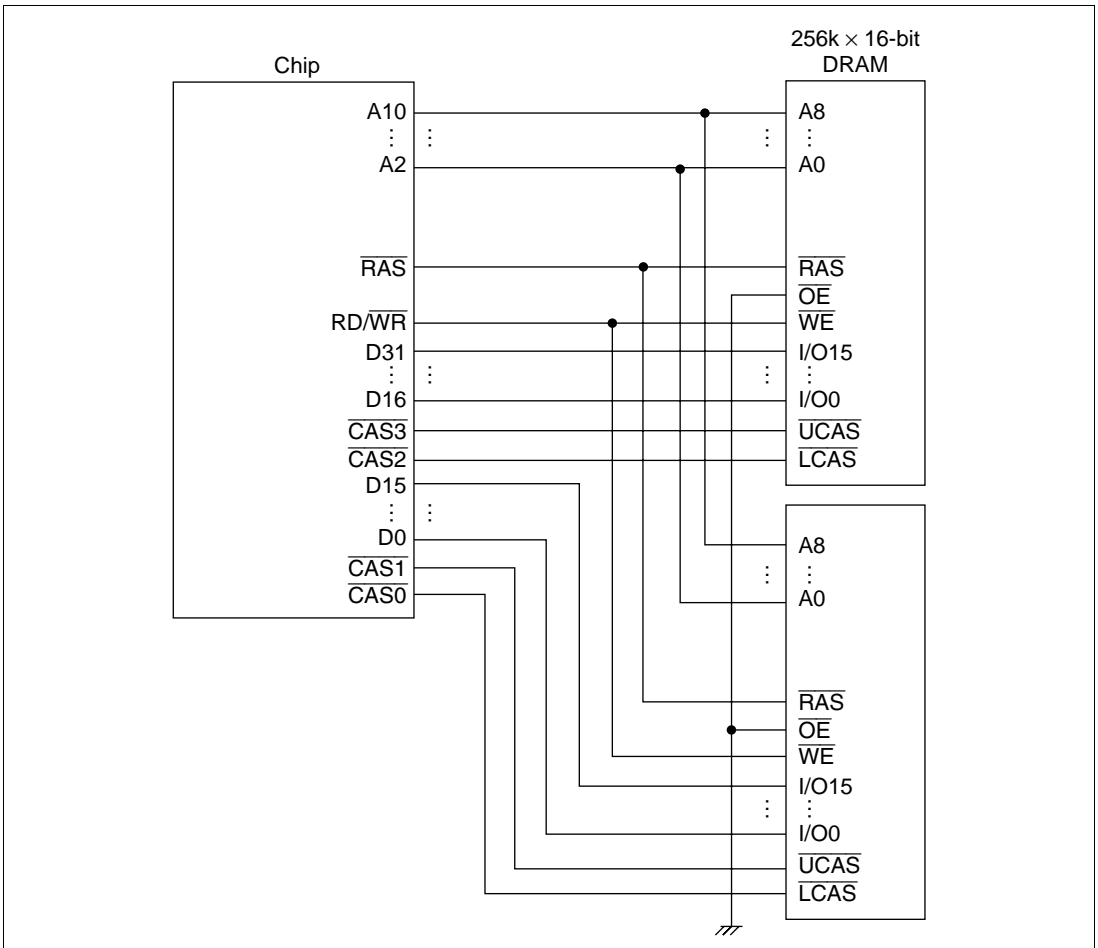

Figure 7.35 Example of DRAM Connection (32-Bit Data Width)

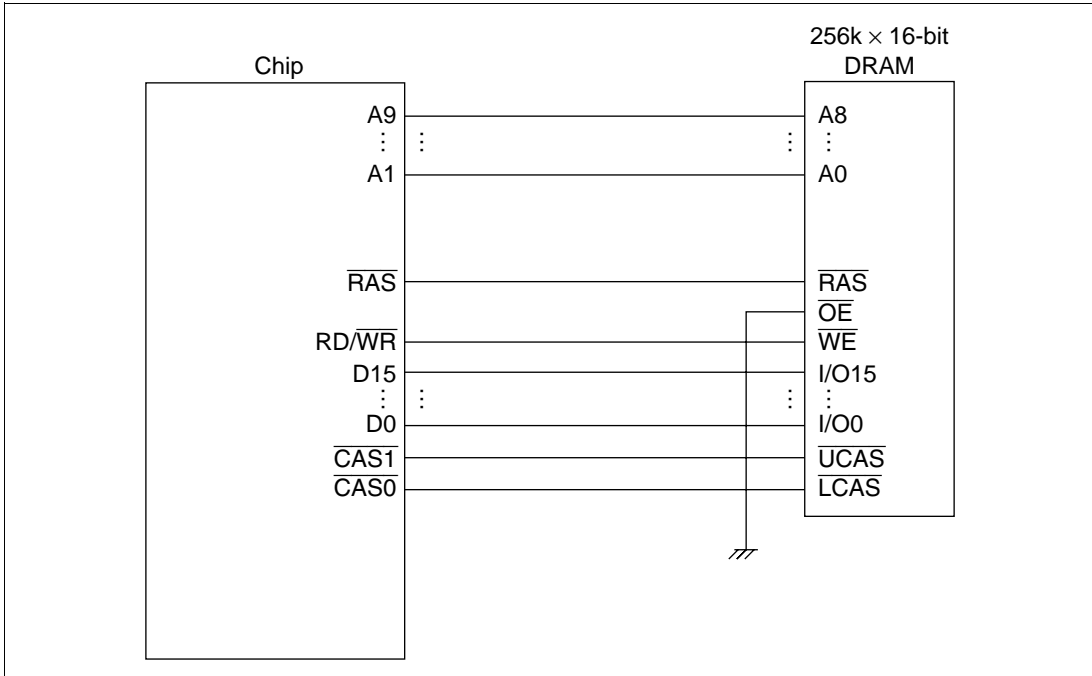

Figure 7.36 Example of DRAM Connection (16-Bit Data Width)

7.6.2 Address Multiplexing

When the CS3 space is set to DRAM, addresses are always multiplexed. This allows DRAMs that require multiplexing of row and column addresses to be connected directly without additional address multiplexing circuits. There are four ways of multiplexing, which can be selected using the AMX1–AMX0 bits in MCR. Table 7.8 illustrates the relationship between the AMX1–AMX0 bits and address multiplexing. Address multiplexing is performed on address output pins A15–A1. The original addresses are output to pins A24–A16. During DRAM accesses, AMX2 is reserved, so set it to 0.

Table 7.8 Relationship between AMX1–AMX0 and Address Multiplexing

AMX1	AMX0	No. of Column Address Bits	Row Address Output	Column Address Output
0	0	8 bits	A23–A9	A15–A1
	1	9 bits	A24–A10	A15–A1
1	0	10 bits	A24–A11* ¹	A15–A1
	1	11 bits	A24–A12* ²	A15–A1

Notes: *1 Address output pin A15 is high.

*2 Address output pins A15 and A14 are high.

7.6.3 Basic Timing

The basic timing of a DRAM access is 3 cycles. Figure 7.37 shows the basic DRAM access timing. T_p is the precharge cycle, T_r is the $\overline{\text{RAS}}$ assert cycle, T_{c1} is the $\overline{\text{CAS}}$ assert cycle, and T_{c2} is the read data fetch cycle. When accesses are consecutive, the T_p cycle of the next access overlaps the T_{c2} cycle of the previous access, so accesses can be performed in a minimum of 3 cycles each.

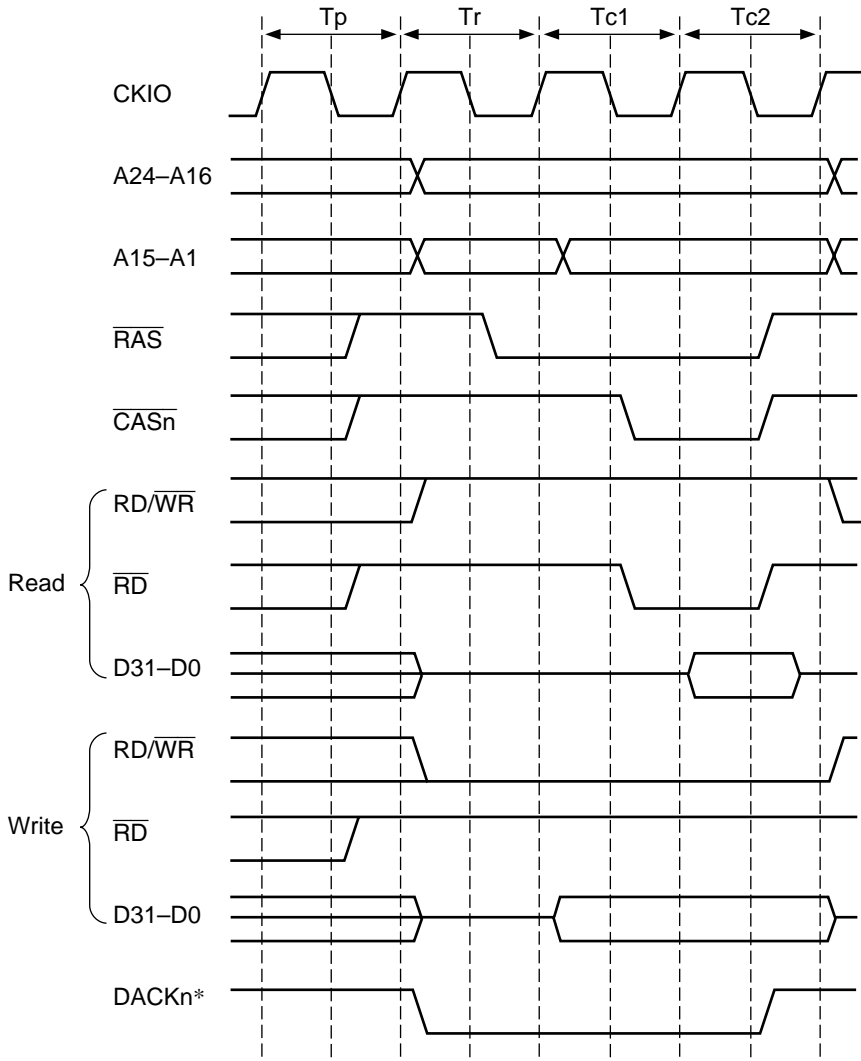

Note: * DACKn waveform when active-low is specified.

Figure 7.37 Basic Access Timing

7.6.4 Wait State Control

When the clock frequency is raised, 1 cycle may not always be sufficient for all states to end, as in basic access. Setting bits in WCR1, WCR2 and MCR enables the state to be lengthened. Figure 7.38 shows an example of lengthening a state using settings.

The T_p cycle (which ensures a sufficient \overline{RAS} precharge time) can be extended from 1 cycle to 2 cycles by insertion of a T_{pw} cycle by means of the TRP1, TRP0 bit in MCR. The number of cycles between \overline{RAS} assert and \overline{CASn} assert can be extended from 1 cycle to 3 cycles by inserting a T_{rw} cycle by means of the RCD1, RCD0 bit in MCR. The number of cycles from \overline{CASn} assert to the end of access can be extended from 1 cycle to 3 cycles by setting the W31/W30 bits in WCR1. When external wait mask bit A3WM in WCR2 is cleared to 0 and bits W31 and W30 in WCR1 are set to a value other than 00, the external wait pin is also sampled, so the number of cycles can be further increased. When bit A3WM in WCR2 is set to 1, external wait input is ignored regardless of the setting of W31 and W30 in WCR1. Figure 7.39 shows the timing of wait state control using the \overline{WAIT} pin.

In either case, when consecutive accesses occur, the T_p cycle access overlaps the T_{c2} cycle of the previous access. In DRAM access, \overline{BS} is not asserted, and so \overline{RAS} , \overline{CASn} , \overline{RD} , etc., should be used for \overline{WAIT} pin control.

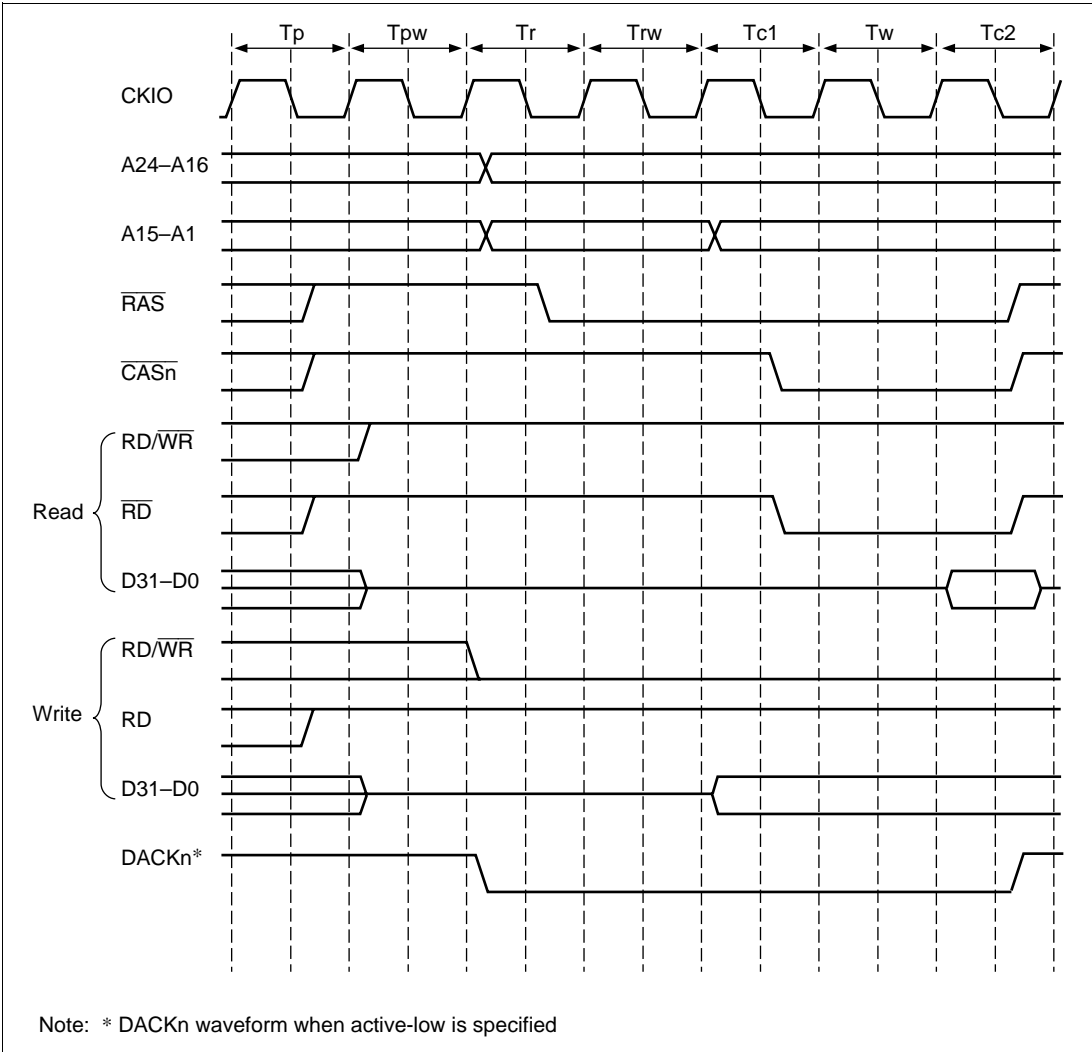
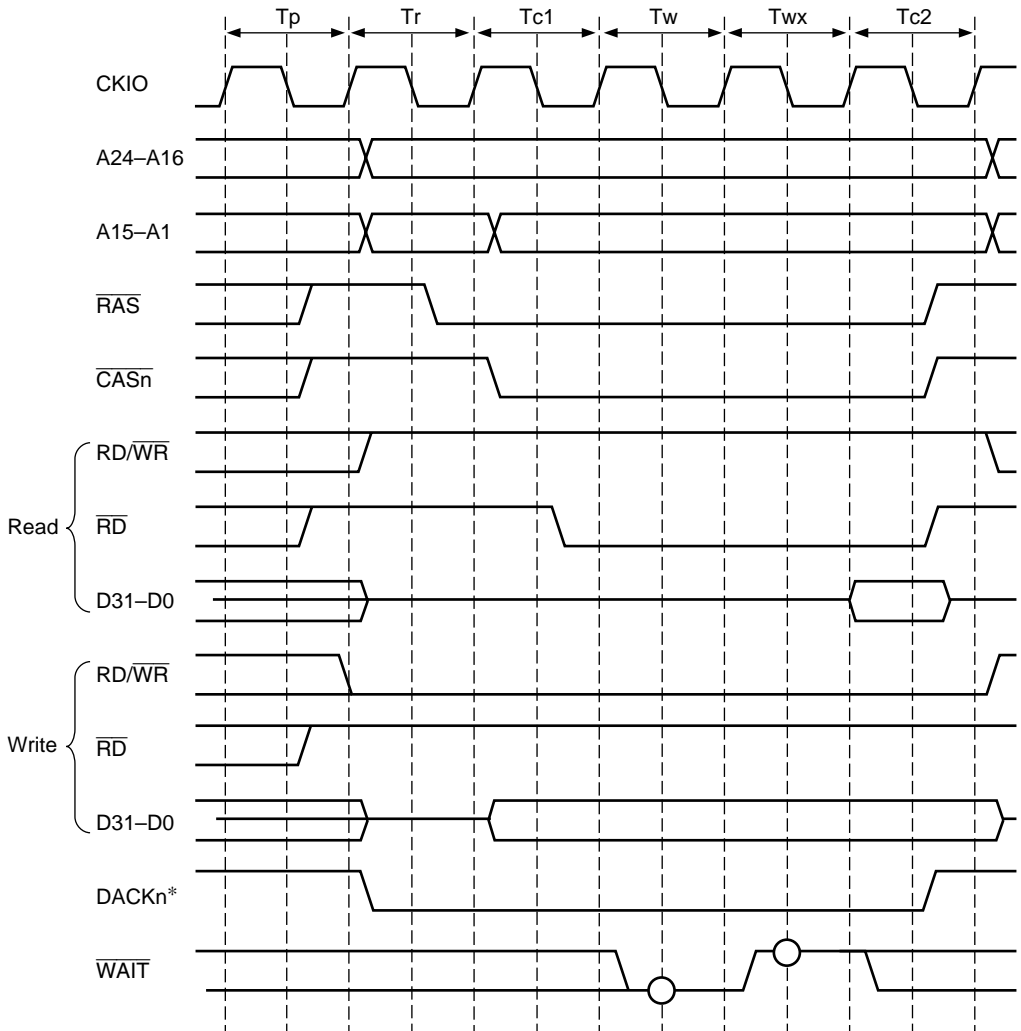

Figure 7.38 Wait State Timing



Note: * \overline{DACK}_n waveform when active-low is specified

Figure 7.39 External Wait State Timing

7.6.5 Burst Access

In addition to the ordinary mode of DRAM access, in which row addresses are output at every access and data is then accessed, DRAM also has a high-speed page mode for use when continuously accessing the same row that enables fast access of data by changing only the column address after the row address is output. Select ordinary access or high-speed page mode by setting the burst enable bit (BE) in MCR. Figure 7.40 shows the timing of burst access in high-speed page mode. When performing burst access, cycles can be inserted using the wait state control function.

An address comparator is provided to detect matches of row addresses in burst mode. When this function is used and the BE bit in MCR is set to 1, setting the MCR's RASD bit (which specifies $\overline{\text{RAS}}$ down mode) to 1 places the SH7616 in $\overline{\text{RAS}}$ down mode, which leaves the $\overline{\text{RAS}}$ signal asserted. The access timing in $\overline{\text{RAS}}$ down mode is shown in figures 7.41 and 7.42. When $\overline{\text{RAS}}$ down mode is used, the refresh cycle must be less than the maximum DRAM $\overline{\text{RAS}}$ assert time t_{RAS} when the refresh cycle is longer than the t_{RAS} maximum.

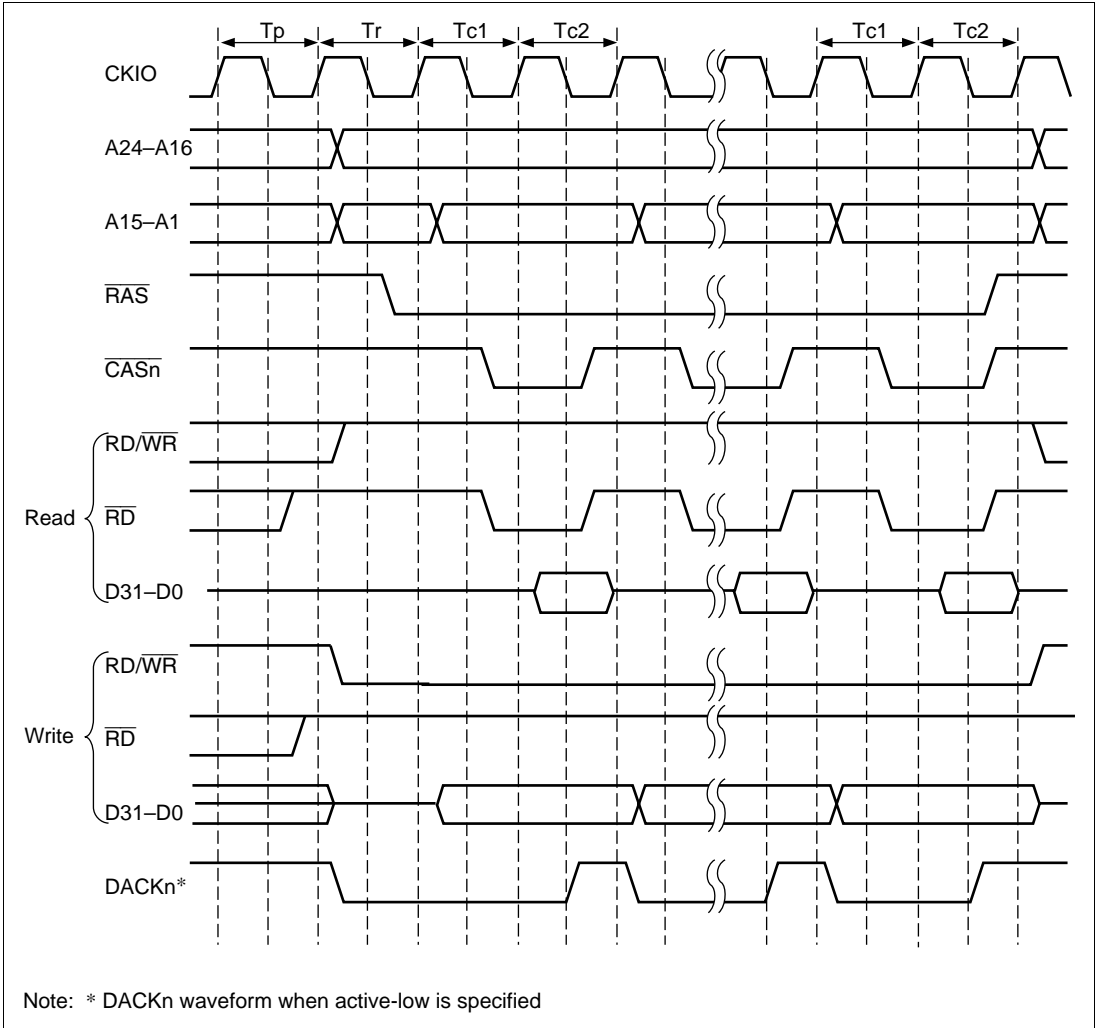
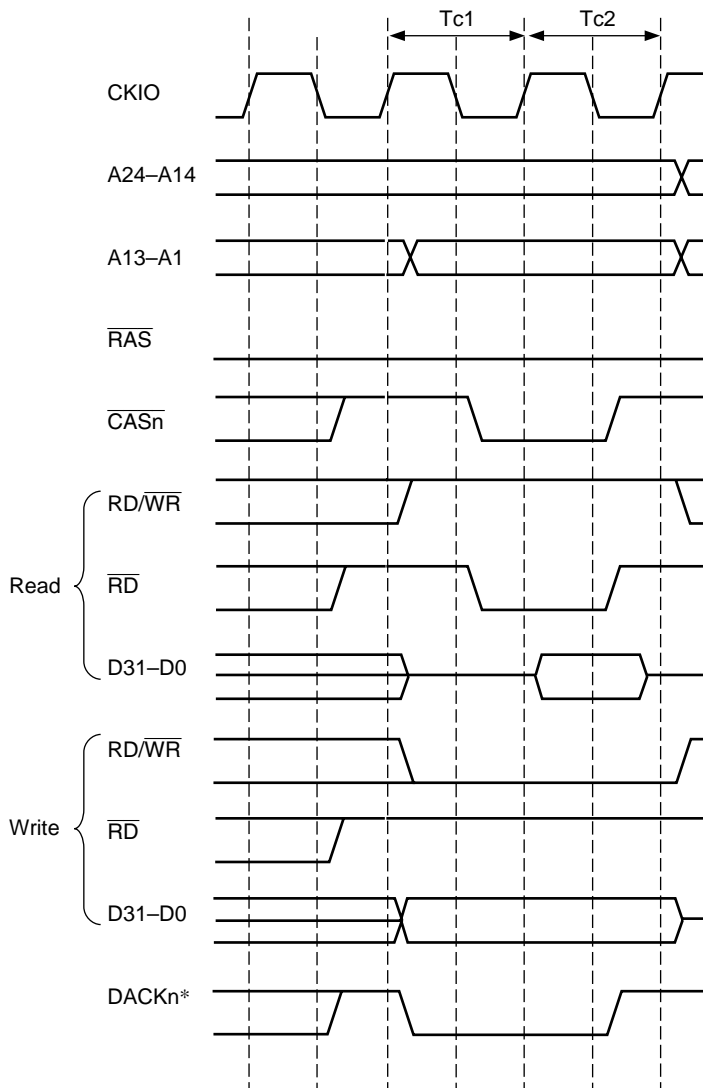
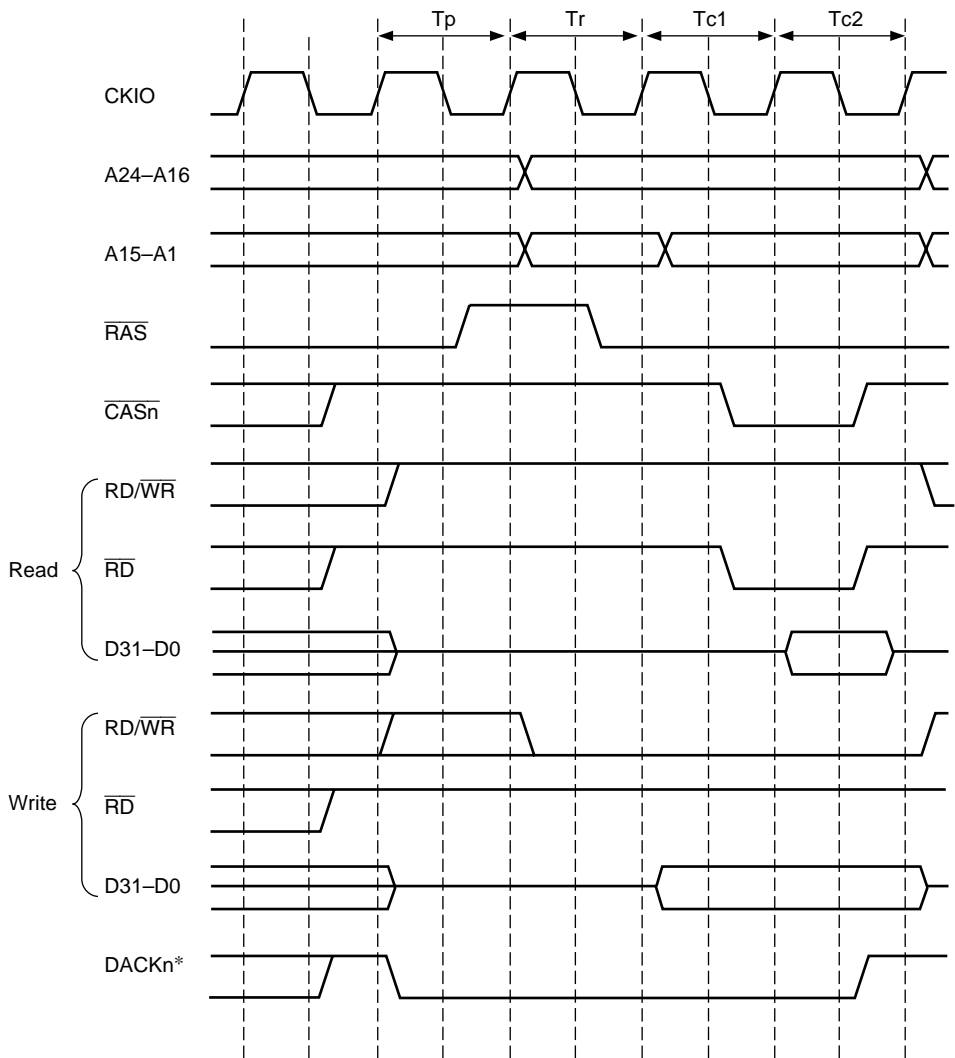

Figure 7.40 Burst Access Timing



Note: * DACKn waveform when active-low is specified

Figure 7.41 $\overline{\text{RAS}}$ Down Mode Same Row Access Timing



Note: * DACKn waveform when active-low is specified

Figure 7.42 $\overline{\text{RAS}}$ Down Mode Different Row Access Timing

7.6.6 EDO Mode

In addition to the kind of DRAM in which data is output to the data bus only while the $\overline{\text{CASn}}$ signal is asserted in a data read cycle, there is another kind provided with an EDO mode in which, while both $\overline{\text{RAS}}$ and $\overline{\text{OE}}$ are asserted, once the $\overline{\text{CASn}}$ signal is asserted data is output to the data bus until $\overline{\text{CASn}}$ is next asserted, even though $\overline{\text{CASn}}$ is negated during this time.

The EDO mode bit (EDO) in MCR allows selection of ordinary access/high-speed page mode burst access or ordinary access/burst access using EDO mode. Since \overline{OE} control is performed in EDO mode DRAM access, the \overline{CAS} and \overline{OE} pins of the SH7616 must be connected to the \overline{OE} pin of the DRAM.

Ordinary access in EDO mode is shown in figure 7.45, and burst access in figure 7.46.

In EDO mode, in order to extend the timing for data output to the data bus in a read cycle until the next assertion of \overline{CAS}_n , the DRAM access time can be increased by delaying the data latch timing by 1/2 cycle, making it at the rise of the CKIO clock.

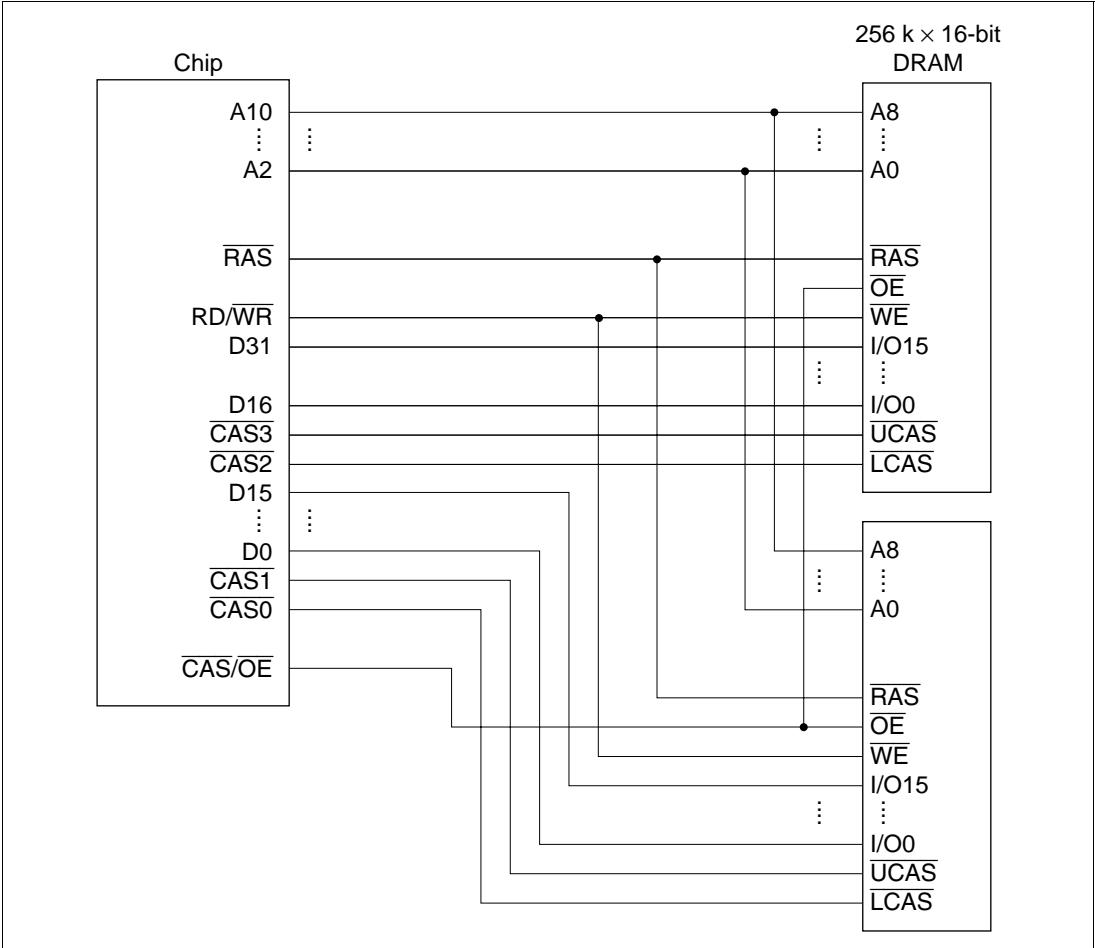

Figure 7.43 Example of EDO DRAM Connection (32-Bit Data Width)

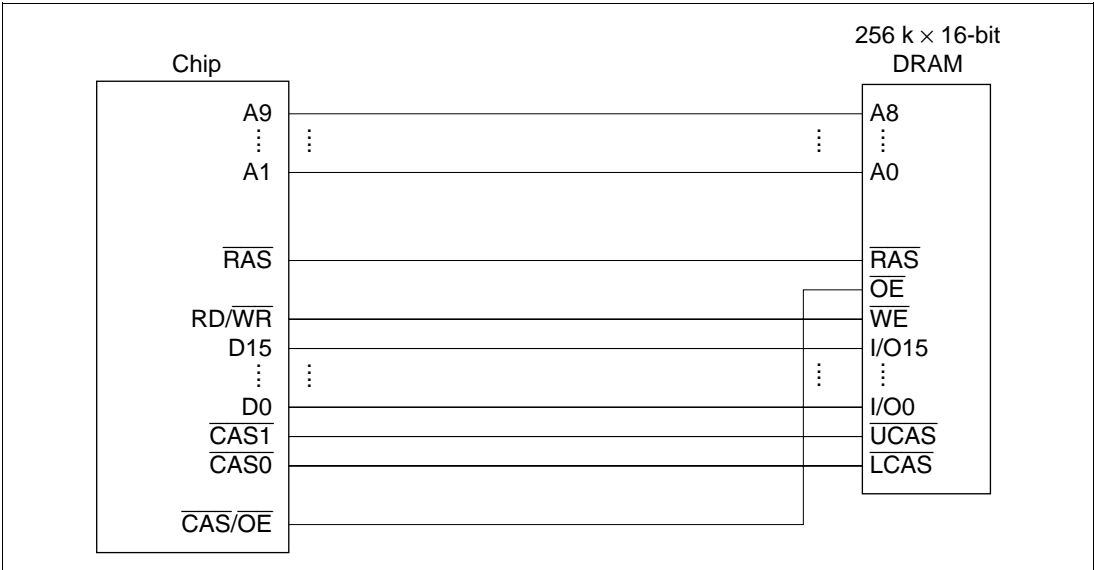
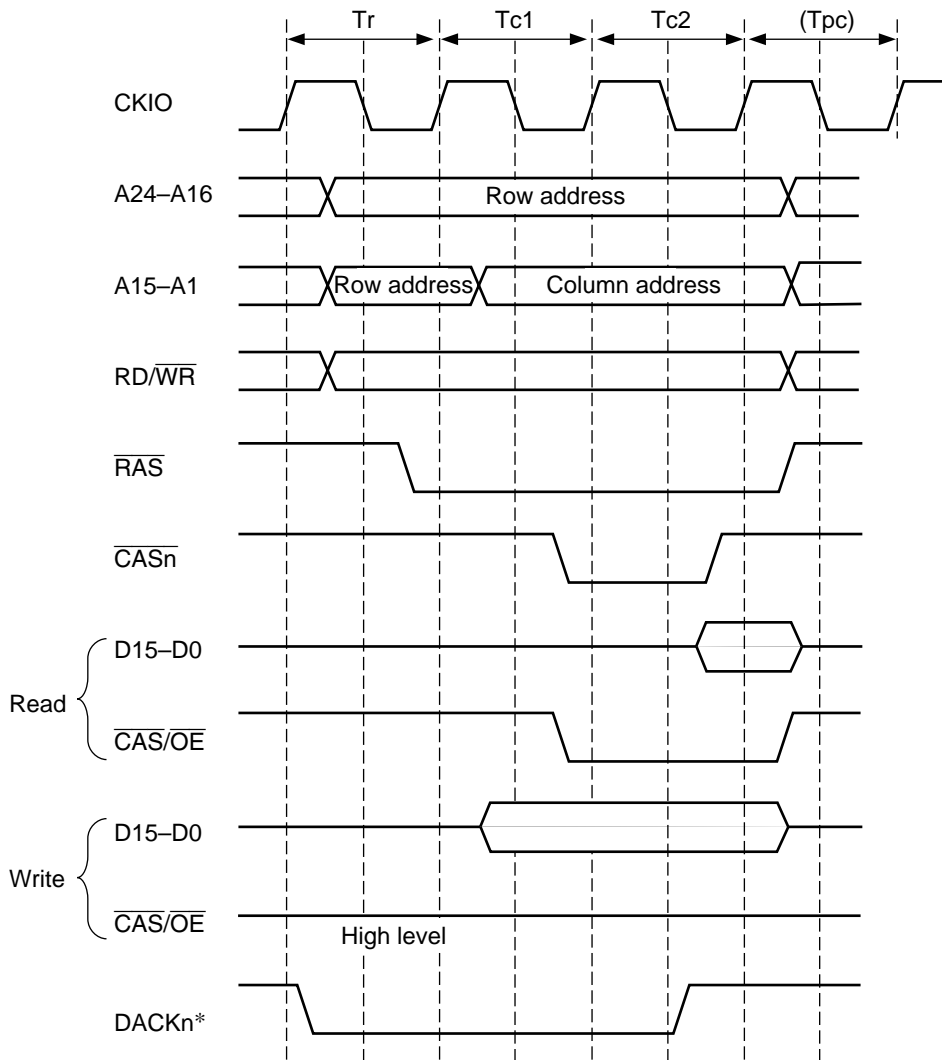

Figure 7.44 Example of EDO DRAM Connection (16-Bit Data Width)



Note: * DACKn waveform when active-low is specified

Figure 7.45 DRAM EDO Mode Ordinary Access Timing

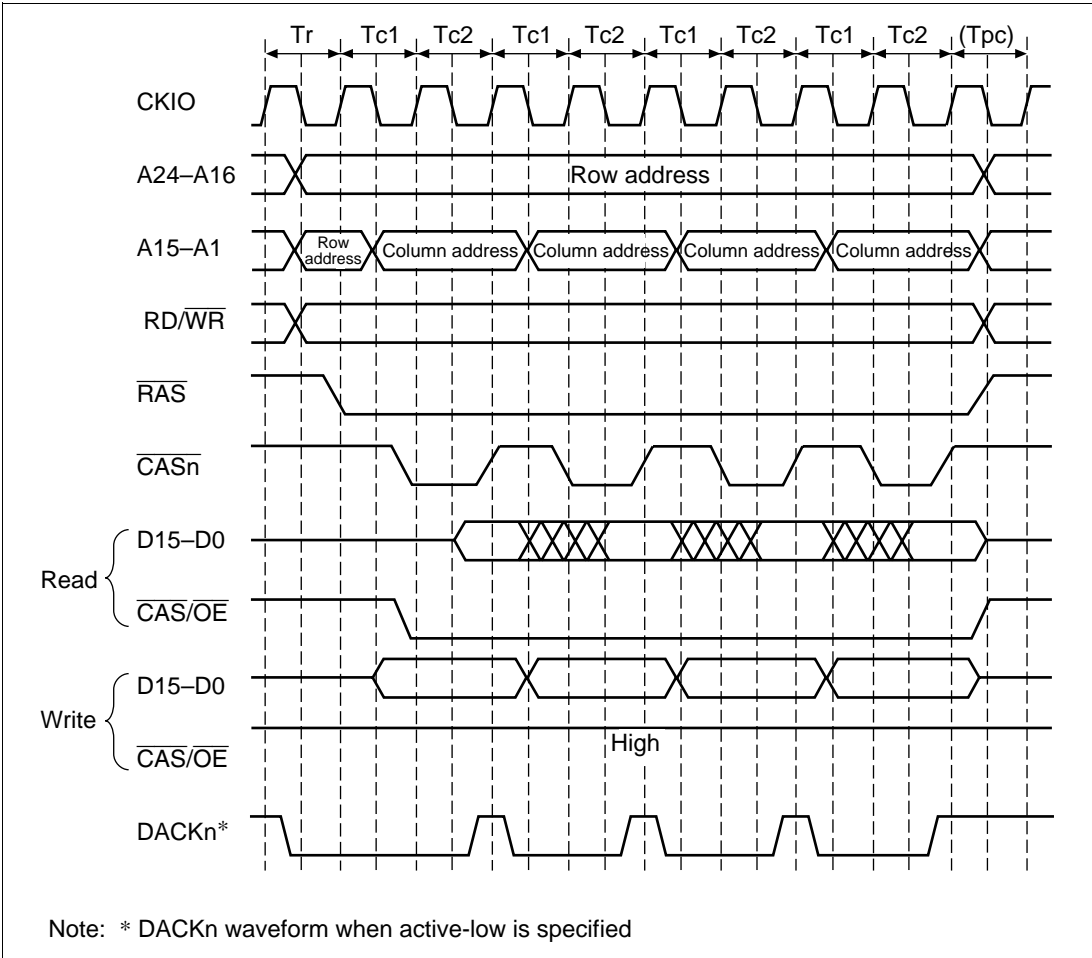
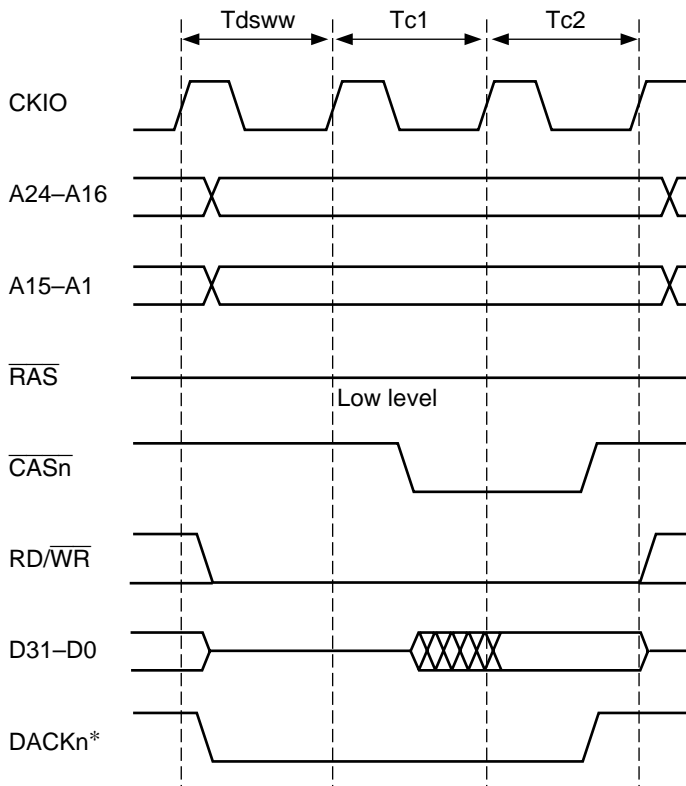

Figure 7.46 DRAM EDO Mode Burst Access Timing

7.6.7 DRAM Single Transfer

Wait states equivalent to the value set in bits DSWW1 and DSWW0 in BCR3 can be inserted between DACKn assertion and CASn assertion in a write in DMA single address transfer mode. Inserting wait states allows the data setup time for external device memory. Figure 7.47 shows the write cycle timing in DMA single transfer mode when DSWW1/DSWW0 = 01 and RASD = 1. The DMA single transfer mode read cycle is the same as a CPU or DMA dual transfer mode read cycle.



Note: * DACKn waveform when active-low is specified

**Figure 7.47 DMA Single Transfer Mode Write Cycle Timing
(\overline{RAS} Down Mode, Same Row Address)**

7.6.8 Refreshing

The bus state controller includes a function for controlling DRAM refreshing. Distributed refreshing using a \overline{CAS} -before- \overline{RAS} refresh cycle can be performed by clearing the RMODE bit to 0 and setting the RFSH bit to 1 in MCR. Consecutive refreshes can be generated by setting bits RRC2–RRC0 in RTCSR. If DRAM is not accessed for a long period, self-refresh mode, which uses little power consumption for data retention, can be activated by setting both the RMODE and RFSH bits to 1.

\overline{CAS} -Before- \overline{RAS} Refreshing: Refreshing is performed at intervals determined by the input clock selected by bits CKS2–CKS0 in RTCSR, and the value set in RTCOR. The RTCOR value and the value of bits CKS2–CKS0 in RTCSR should be set so as to satisfy the refresh interval specification for the DRAM used. First make the settings for RTCOR, RTCNT, and the RMODE and RFSH bits in MCR, then make the CKS2–CKS0 and RRC2–RRC0 settings in RTCSR. When

the clock is selected by CKS2–CKS0, RTCNT starts counting up from the value at that time. The RTCNT value is constantly compared with the RTCOR value, and when the two values match, a refresh request is generated and the number of CAS-before-RAS refreshes set in bits RRC2–RRC0 are performed. At the same time, RTCNT is cleared to zero and the count-up is restarted. Figure 7.48 shows the $\overline{\text{CAS}}$ -before- $\overline{\text{RAS}}$ refresh cycle timing.

The number of RAS assert cycles in the refresh cycle is specified by bits TRAS1 and TRAS0 in MCR. As with ordinary accesses, the specification of the $\overline{\text{RAS}}$ precharge time in the refresh cycle follows the setting of bits TRP1 and TRP0 in MCR.

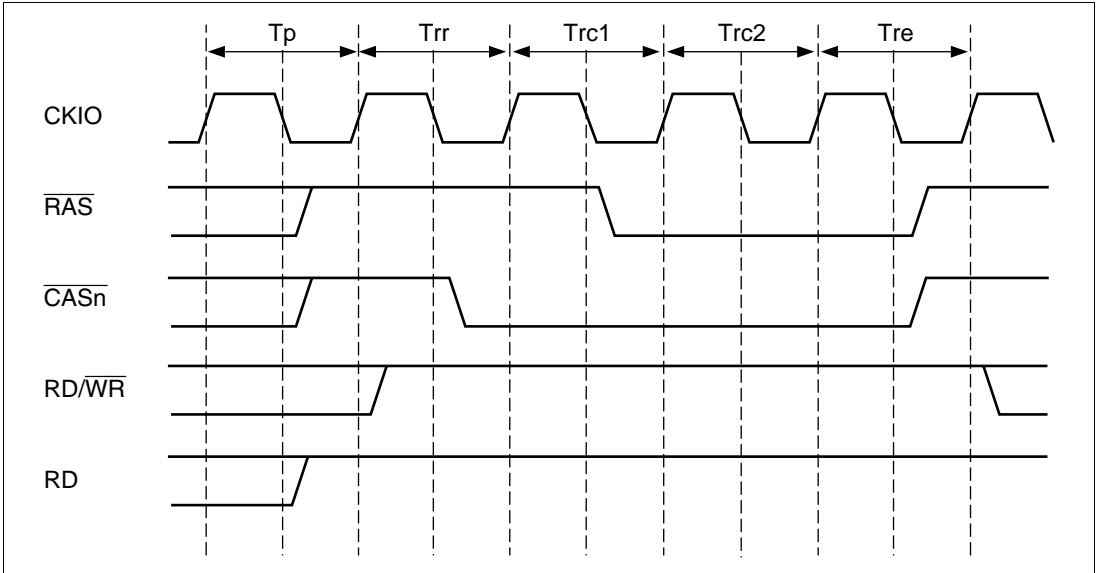

Figure 7.48 DRAM $\overline{\text{CAS}}$ -before- $\overline{\text{RAS}}$ Refresh Cycle Timing

Self-Refreshing: A self-refresh is started by setting both the RMODE bit and the RFSH bit to 1. During the self-refresh, DRAM cannot be accessed. Self-refreshing is cleared by clearing the RMODE bit to 0. Self-refresh timing is shown in figure 7.49. Settings must be made so that self-refresh clearing and data retention are performed correctly, and $\overline{\text{CAS}}$ -before- $\overline{\text{RAS}}$ refreshing is immediately performed at the correct intervals. When self-refreshing is started from the state in which $\overline{\text{CAS}}$ -before- $\overline{\text{RAS}}$ refreshing is set, or when exiting standby mode by means of a manual reset or NMI, auto-refreshing is restarted if RFSH is set to 1 and RMODE is cleared to 0 when self-refresh mode is cleared. If the transition from clearing of self-refresh mode to starting auto-refresh takes time, this time should be taken into consideration when setting the initial value of RTCNT. When the RTCNT value is set to RTCOR-1, the refresh can be started immediately.

After self-refreshing has been set, the self-refresh state continues even if the chip standby state is entered using the chip's standby function. The self-refresh state is also maintained even after recovery from standby mode by means of NMI input.

In the case of a power-on reset, the bus state controller's registers are initialized, and therefore the self-refresh state is cleared.

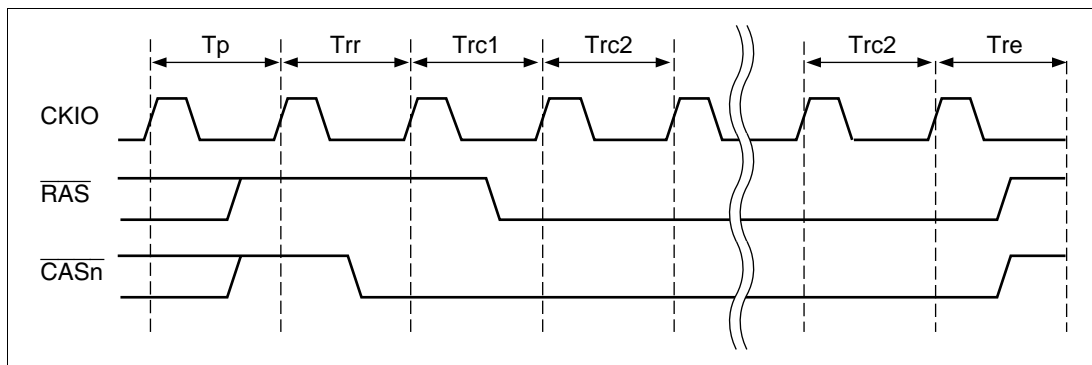

Figure 7.49 DRAM Self-Refresh Cycle Timing

7.6.9 Power-On Sequence

When DRAM is used after the power is turned on, there is a requirement for a waiting period during which accesses cannot be performed (100 μ s or 200 μ s minimum) followed by at least the prescribed number of dummy $\overline{\text{CAS}}$ -before- $\overline{\text{RAS}}$ refresh cycles (usually 8). The bus state controller (BSC) does not perform any special operations for the power-on reset, so the required power-on sequence must be implemented by the initialization program executed after a power-on reset.

7.7 Burst ROM Interface

Set the BSTROM bit in BCR1 to set the CS0 space for connection to burst ROM. The burst ROM interface is used to permit fast access to ROMs that have the nibble access function. Figure 7.51 shows the timing of nibble accesses to burst ROM. Set for two wait cycles. The access is basically the same as an ordinary access, but when the first cycle ends, only the address is changed. The CS0 signal is not negated, enabling the next access to be conducted without the T1 cycle required for ordinary space access. From the second time on, the T1 cycle is omitted, so access is 1 cycle faster than ordinary accesses. Currently, the nibble access can only be used on 4-address ROM. This function can only be utilized for word or longword reads to 8-bit ROM and longword reads to 16-bit ROM. Mask ROMs have slow access speeds and require 4 instruction fetches for 8-bit widths and 16 accesses for cache filling. Limited support of nibble access was thus added to alleviate this problem. When connecting to an 8-bit width ROM, a maximum of 4 consecutive accesses are performed; when connecting to a 16-bit width ROM, a maximum of 2 consecutive accesses are performed. Figure 7.50 shows the relationship between data width and access size. For cache filling and DMAC 16-byte transfers, longword accesses are repeated 4 times.

When one or more wait states are set for a burst ROM access, the $\overline{\text{WAIT}}$ pin is sampled. When the burst ROM is set and 0 specified for waits, there are 2 access cycles from the second time on.

Figure 7.52 shows the timing.

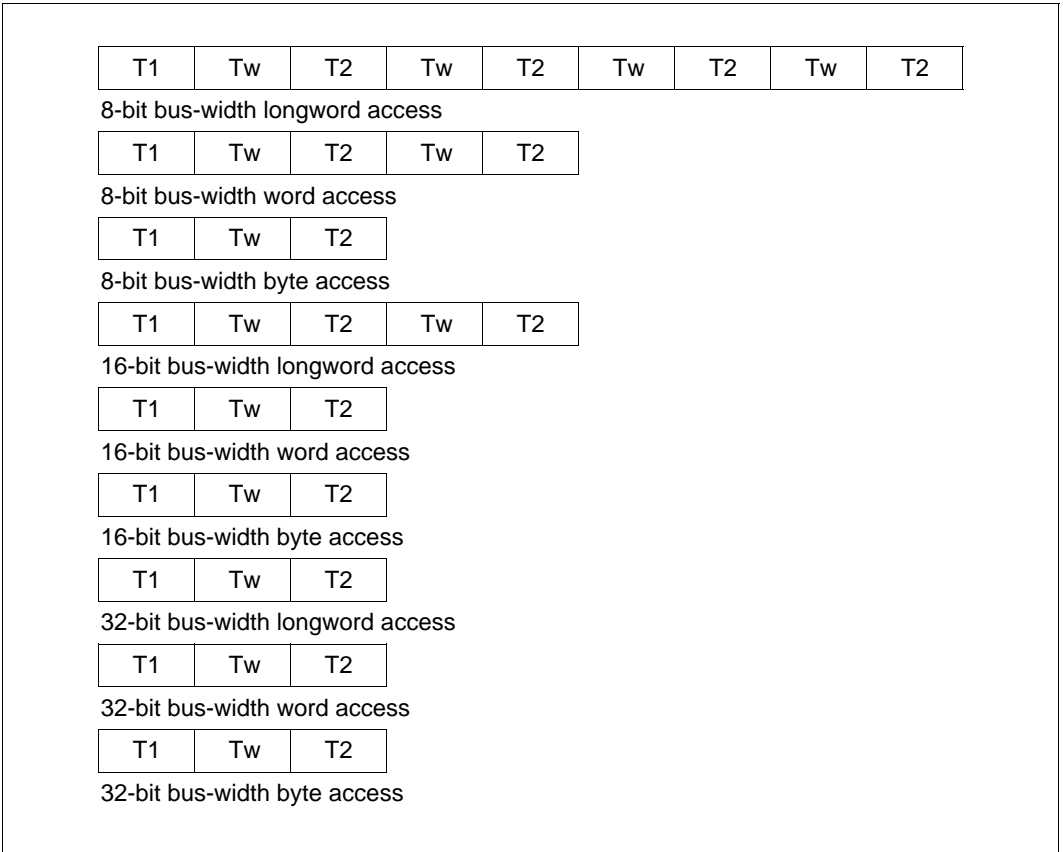
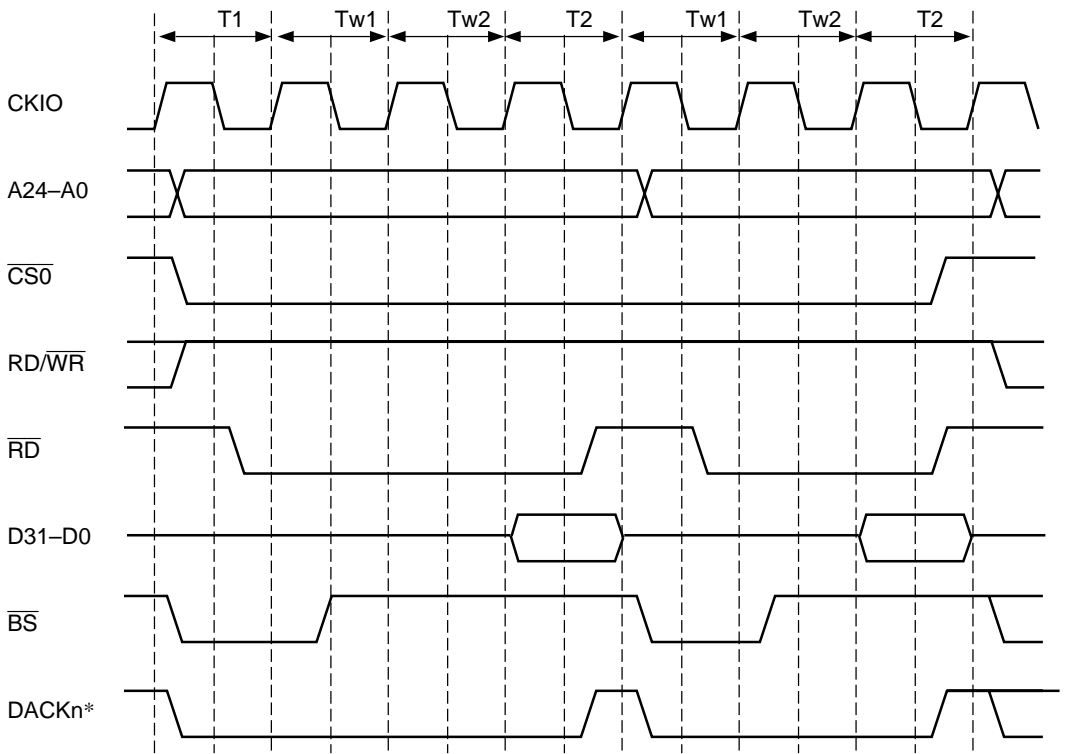
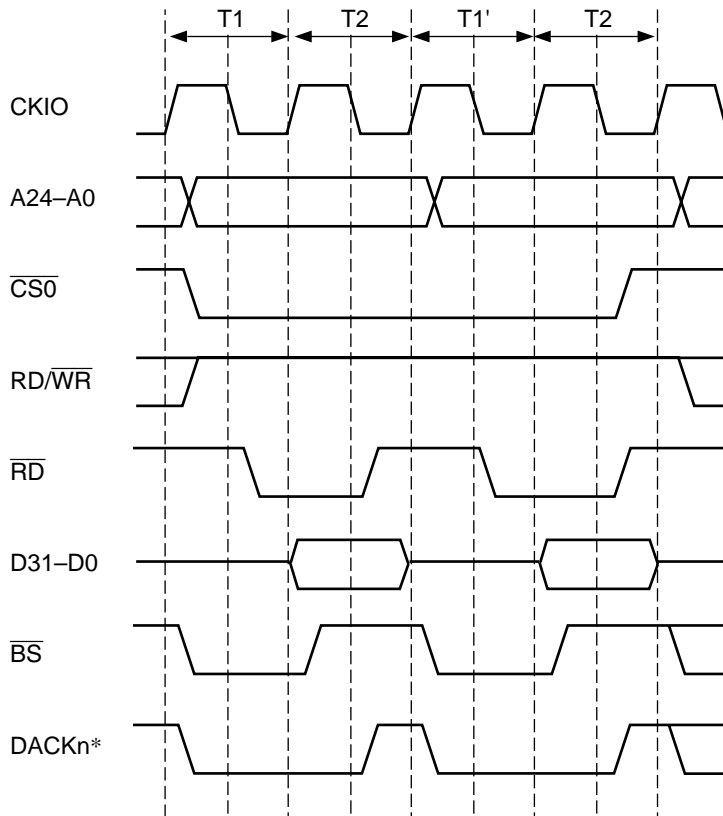

Figure 7.50 Data Width and Burst ROM Access (1 Wait State)



Note: * DACKn waveform when active-low is specified.

Figure 7.51 Burst ROM Nibble Access (2 Wait States)



Note: * DACKn waveform when active-low is specified.

Figure 7.52 Burst ROM Nibble Access (No Wait States)

7.8 Idles between Cycles

Because operating frequencies have become high, when a read from a slow device is completed, data buffers may not go off in time to prevent data conflicts with the next access. This lowers device reliability and causes errors. To prevent this, a function has been added to avoid data conflicts that memorizes the space and read/write state of the preceding access and inserts an idle cycle in the access cycle for those cases in which problems are found to occur when the next access starts up. The BSC checks whether a wait is to be inserted in two cases: if a read cycle is followed immediately by a read access to a different CS space, and if a read access is followed immediately by a write from the chip. When the chip is writing continuously, the data direction is always from the chip to other memory, and there are no particular problems. Neither is there any particular problem if the following read access is to the same CS space, since data is output from the same data buffer. The number of idle cycles to be inserted into the access cycle when reading from another CS space, or performing a write, after a read from the CS3 space, is specified by the IW31 and IW30 bits in WCR1. Likewise, IW21 and IW20 specify the number of idle cycles after CS2 reads, IW11 and IW10 specify the number after CS1 reads, and IW01 and IW00 specify the number after CS0 reads. The number of idle cycles after a CS4 read is specified by the IW41 and IW40 bits in WCR2. From 0, 1, 2, or 4 cycles can be specified. When there is already a gap between accesses, the number of empty cycles is subtracted from the number of idle cycles before insertion. When a write cycle is performed immediately after a read access, 1 idle cycle is inserted even when 0 is specified for waits between access cycles.

When the chip shifts to a read cycle immediately after a write, the write data becomes high impedance when the clock rises, but the \overline{RD} signal, which indicates read cycle data output enable, is not asserted until the clock falls. The result is that no idles are inserted into the cycle.

When bus arbitration is being performed, an empty cycle is inserted for arbitration, so no is inserted between cycles.

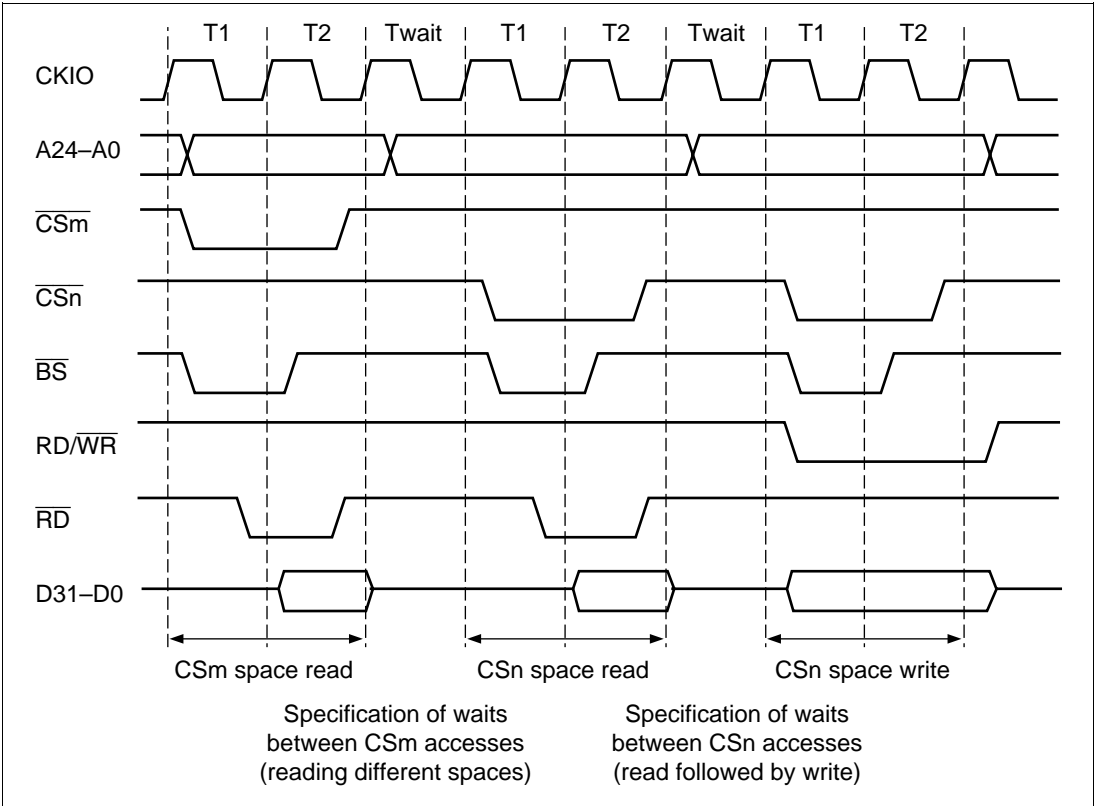

Figure 7.53 Idles between Cycles

7.9 Bus Arbitration

The chip has a bus arbitration function that, when a bus release request is received from an external device, releases the bus to that device after the bus cycle being executed is completed.

The chip keeps the bus under normal conditions and permits other devices to use the bus by releasing it when they request its use.

In the following explanation, external devices requesting the bus are called slaves.

The chip has three internal bus masters, the CPU, the DMAC and the E-DMAC. When synchronous DRAM or DRAM is connected and refresh control is performed, the refresh request becomes a fourth master. In addition to these, there are also bus requests from external devices. The priority for bus requests when they occur simultaneously is as follows.

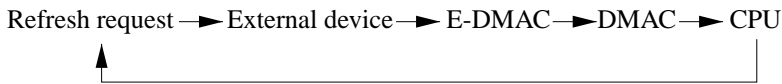

However, only one E-DMAC channel can hold the bus during one bus-mastership cycle.

The E-DMAC has two channels to handle both transmission and reception. Arbitration between the channels is performed automatically within the E-DMAC module, with bus mastership alternating between the transmit channel and the receive channel. For arbitration between the two DMAC channels, either fixed priority mode or round robin mode can be selected by means of the priority mode bit (PR) in the DMA operation register (DMAOR).

When the bus is being passed between slave and master, all bus control signals are negated before the bus is released to prevent erroneous operation of the connected devices. When the bus is transferred, also, the bus control signals begin bus driving from the negated state. The master and slave passing the bus between them drive the same signal values, so output buffer conflict is avoided. A pull-up resistance is required for the bus control signals to prevent malfunction caused by external noise when they are at high impedance.

Bus permission is granted at the end of the bus cycle. When the bus is requested, the bus is released immediately if there is no ongoing bus cycle. If there is a current bus cycle, the bus is not released until the bus cycle ends. Even when a bus cycle does not appear to be in progress when viewed from off-chip, it is not possible to determine immediately whether the bus has been released by looking at \overline{CS}_n or other control signals, since a bus cycle (such as wait insertion between access cycles) may have been started internally. The bus cannot be released during burst transfers for cache filling, DMAC 16-byte block transfers (16 + 16 = 32-byte transfers in dual address mode), or E-DMAC 16-byte block transfers. Likewise, the bus cannot be released between the read and write cycles of a TAS instruction. Arbitration is also not performed between multiple bus cycles produced by a data width smaller than the access size, such as a longword access to an 8-bit data width memory. Bus arbitration is performed between external vector fetch, PC save, and SR save cycles during interrupt handling, which are all independent accesses.

Because the CPU is connected to cache memory by a dedicated internal bus, cache memory can be read even when the bus is being used by another bus master on the chip or externally. When writing from the CPU, an external write cycle is produced. Since the internal bus that connects the CPU, DMAC, and on-chip peripheral modules can operate in parallel to the external bus, both read and write accesses from the CPU to on-chip peripheral modules and from the DMAC to on-chip peripheral modules are possible even if the external bus is not held.

Figures 7.54 (a) and 7.54 (b) show the timing charts in the cases that bus requests occur simultaneously from the E-DMAC, DMAC, and CPU. These cases are based on the following settings:

- The CS2 and CS3 spaces are set for synchronous DRAM.
- The CAS latency is one cycle.

- The E-DMAC is enabled at both the transmitter and receiver (the buffer and descriptor use the CS3 space).
- The DMAC is enabled in only one channel that is set to auto-request mode, cycle-steal mode, and 16-byte dual-address transmission (CS2 space).
- Burst read and single write are set to synchronous DRAM.

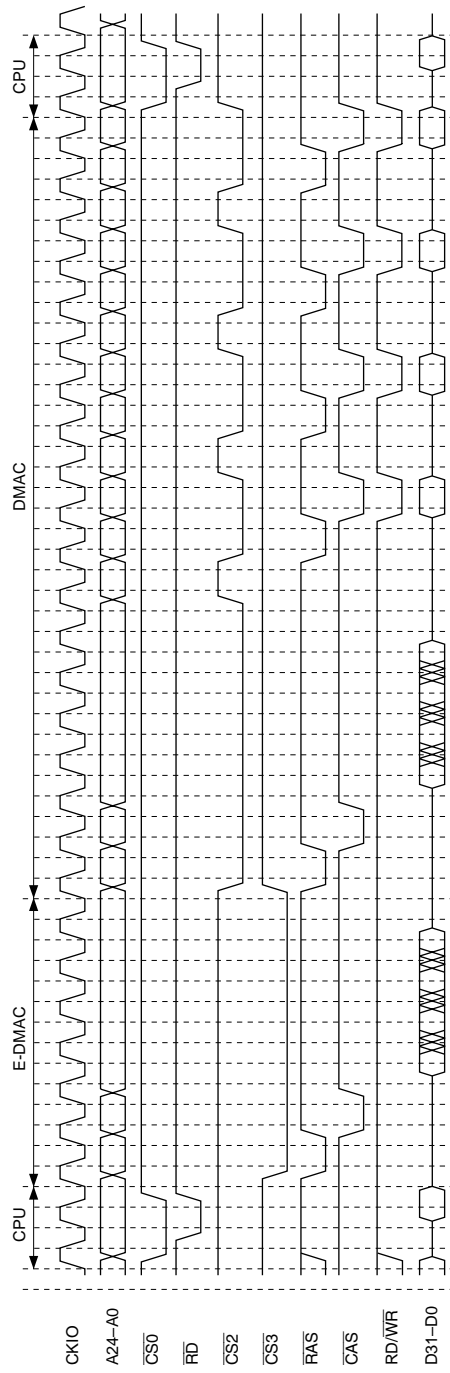

Figure 7.54 (a) Bus Arbitration Timing
(E-DMAC Read → DMAC 16-Byte Transmission → CPU Read)

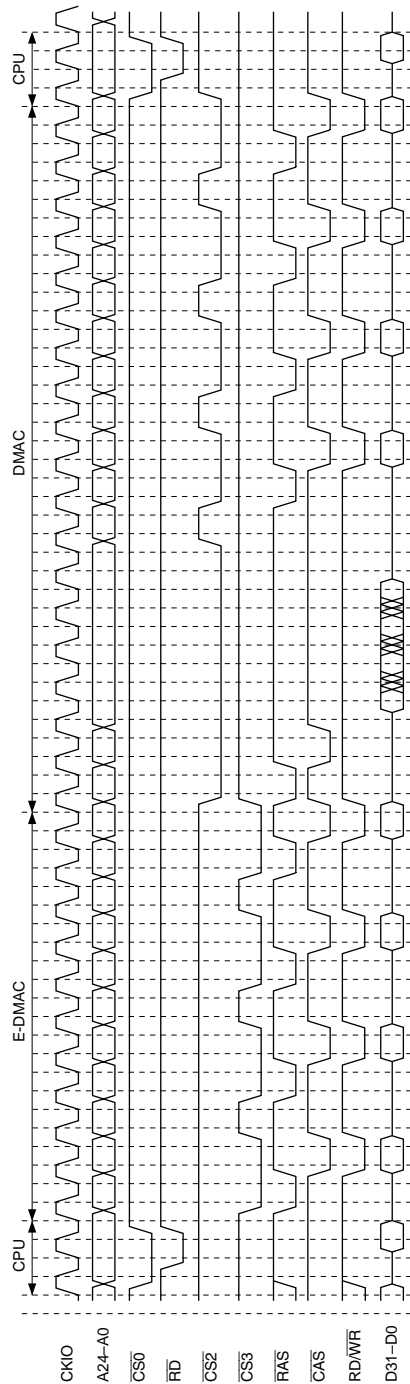

Figure 7.54 (b) Bus Arbitration Timing
 (E-DMAC Write → DMAC 16-Byte Transmission → CPU Read)

7.9.1 Master Mode

The chip keeps the bus unless it receives a bus request. When a bus release request ($\overline{\text{BRLS}}$) assertion (low level) is received from an external device, buses are released and a bus grant ($\overline{\text{BGR}}$) is asserted (low level) as soon as the bus cycle being executed is completed. When it receives a negated (high level) $\overline{\text{BRLS}}$ signal, indicating that the slave has released the bus, it negates the $\overline{\text{BGR}}$ (to high level) and begins using the bus. When the bus is released, all output and I/O signals related to the bus interface are changed to high impedance, except for the CKE signal for the synchronous DRAM interface, the $\overline{\text{BGR}}$ signal for bus arbitration, and DMA transfer control signals DACK0 and DACK1.

When the DRAM has finished precharging, the bus is released. The synchronous DRAM also issues a precharge command to the active bank. After this is completed, the bus is released.

The specific bus release sequence is as follows. First, the address bus and data bus become high impedance synchronously with a rise of the clock. Half a cycle later, the bus use enable signal is asserted synchronously with a fall of the clock. Thereafter the bus control signals ($\overline{\text{BS}}$, $\overline{\text{CSn}}$, $\overline{\text{RAS}}$, $\overline{\text{CASn}}$, $\overline{\text{WEn}}$, $\overline{\text{RD}}$, $\overline{\text{RD/WR}}$) become high impedance at a rise of the clock. These bus control signals are driven high at least 2 cycles before they become high impedance. Sampling for bus request signals occurs at the clock fall.

The sequence when the bus is taken back from the slave is as follows. When the negation of $\overline{\text{BRLS}}$ is detected at a clock fall, high-level driving of the bus control signals starts half a cycle later. The bus use enable signal is then negated at the next clock fall. The address bus and data bus are driven starting at the next clock rise. The bus control signals are asserted and the bus cycle actually starts from the same clock rise at which the address and data signals are driven, at the earliest. Figure 7.55 shows the timing of bus arbitration.

To reduce the overhead due to arbitration with a user-designed slave, a number of consecutive bus accesses may be attempted. In this case, to insure dependable refreshing, the design must provide for the slave to release the bus before it has held it for a period exceeding the refresh cycle. The SH7616 is provided with the REFOUT pin to send a signal requesting the bus while refresh execution is being kept waiting. REFOUT is asserted while refresh execution is being kept waiting until the bus is acquired. When the external slave device receives this signal and releases the bus, the bus is returned to the chip and refreshing can be executed.

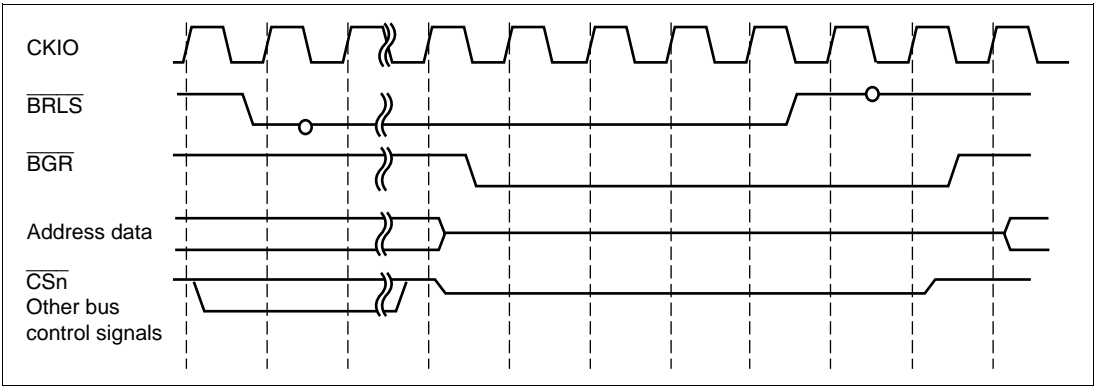

Figure 7.55 Bus Arbitration

7.10 Additional Items

7.10.1 Resets

The bus state controller is completely initialized only in a power-on reset. All signals are immediately negated, regardless of whether or not the chip is in the middle of a bus cycle. Signal negation is simultaneous with turning the output buffer off. All control registers are initialized. In standby mode, sleep mode, and a manual reset, no bus state controller control registers are initialized. When a manual reset is performed, the currently executing bus cycle only is completed, and then the chip waits for an access. When a cache-filling or DMAC/E-DMAC 16-byte transfer is executing, the CPU, DMAC, or E-DMAC that is the bus master ends the access in a longword unit, since the access request is canceled by the manual reset. This means that when a manual reset is executed during a cache filling, the cache contents can no longer be guaranteed. During a manual reset, the RTCNT does not count up, so no refresh request is generated, and a refresh cycle is not initiated. To preserve the data of the DRAM and synchronous DRAM, the pulse width of the manual reset must be shorter than the refresh interval.

The bus-release operation of this LSI during a manual reset is described below.

- $\overline{\text{BRLS}}$ signal is asserted before transition to manual reset state and continues to be asserted during manual reset
In this LSI, the $\overline{\text{BGR}}$ signal is continuously asserted to retain the bus-release state.
- $\overline{\text{BRLS}}$ signal is asserted before transition to manual reset state and negated during manual reset
In this LSI, the $\overline{\text{BGR}}$ signal is negated to acquire the bus.
- $\overline{\text{BRLS}}$ signal is asserted during manual reset
In this LSI, the $\overline{\text{BGR}}$ signal is not asserted until the manual reset is released.

7.10.2 Access as Viewed from CPU, DMAC or E-DMAC

The chip is internally divided into three buses: cache, internal, and peripheral. The CPU and cache memory are connected to the cache bus, the DMAC, E-DMAC and bus state controller are connected to the internal bus, and the low-speed peripheral devices and mode registers are connected to the peripheral bus. On-chip memory other than cache memory and the user break controller are connected to both the cache bus and the internal bus. The internal bus can be accessed from the cache bus, but not the other way around. The peripheral bus can be accessed from the internal bus, but not the other way around. This results in the following.

The DMAC can access on-chip memory other than cache memory, but cannot access cache memory. When the DMAC causes a write to external memory, the external memory contents and the cache contents may be different. When external memory contents are rewritten by a DMA transfer, the cache memory must be purged by software if there is a possibility that the data for that address is present in the cache.

When the CPU starts a read access, if the access is to a cache area, a cache search is first performed. This takes one cycle. If there is data in the cache, it fetches it and completes the access. If there is no data in the cache, a cache filling is performed via the internal bus, so four consecutive longword reads occur. For misses that occur when byte or word operands are accessed or branches occur to odd word boundaries ($4n + 2$ addresses), the filling is always performed by longword accesses on the chip-external interface. In the cache-through area, the access is to the actual access address. When the access is an instruction fetch, the access size is always longword.

For cache-through areas and on-chip peripheral module read cycles, after an extra cycle is added to determine the cycle, the read cycle is started through the internal bus. Read data is sent to the CPU through the cache bus.

When write cycles access the cache area, the cache is searched. When the data of the relevant address is found, it is written here. The actual write occurs in parallel to this via the internal bus in write-through mode. In write-back mode, the actual write is not performed until a replace operation occurs for the relevant address. When the right to use the internal bus is held, the CPU is notified that the write is completed without waiting for the end of the actual off-chip write. When the right to use the internal bus is not held, as when it is being used by the DMAC or the like, there is a wait until the bus is acquired before the CPU is notified of completion.

Accesses to cache-through areas and on-chip peripheral modules work the same as in the cache area, except for the cache search and write.

Because the bus state controller has one level of write buffer, the internal bus can be used for another access even when the chip-external bus cycle has not ended. After a write has been performed to low-speed memory off the chip, performing a read or write with an on-chip peripheral module enables an access to the on-chip peripheral module without having to wait for the completion of the write to low-speed memory.

During reads, the CPU always has to wait for the end of the operation. To immediately continue processing after checking that the write to the device of actual data has ended, perform a dummy read access to the same address consecutively to check that the write has ended.

The bus state controller's write buffer functions in the same way during accesses from the DMAC. A dual-address DMA transfer thus starts in the next read cycle without waiting for the end of the write cycle. When both the source address and destination address of the DMA are external spaces to the chip, however, it must wait until the completion of the previous write cycle before starting the next read cycle.

The E-DMAC can perform access involving external memory, but not access involving any on-chip memory or peripheral modules.

7.10.3 STATS1 and STATS0 Pins

The SH7616 has two pins, STATS1 and STATS0, to identify the bus master status. The signals output from these pins show the external access status. Encoded output is provided for the following categories: CPU (cache hit/cache disable), DMAC (external access only), E-DMAC, and Others (refresh, internal access, etc.). All output is synchronized with the address signals. The encoding patterns are shown in table 7.9, and the output timing in figure 7.56.

Table 7.9 Encoding Patterns

Identification	STATS1	STATS0
CPU	0	0
DMAC		1
E-DMAC	1	0
Others		1

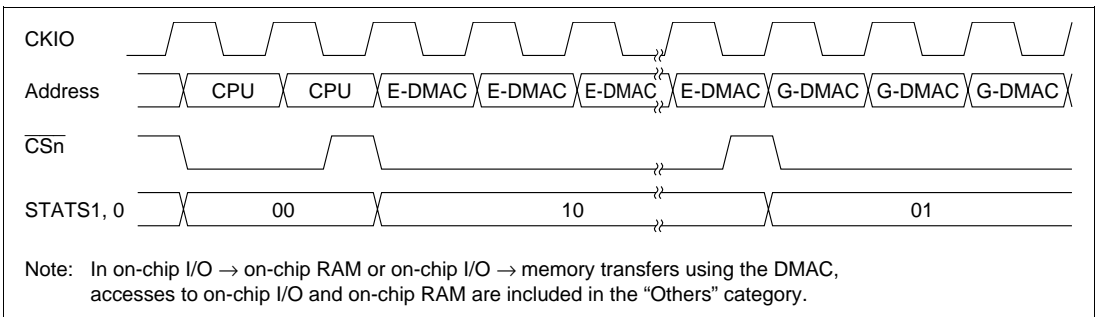

Figure 7.56 STATS Output Timing

7.10.4 $\overline{\text{BUSHiZ}}$ Specification

The $\overline{\text{BUSHiZ}}$ pin is needed when the SH7616 is connected to a PCI controller via a PCI bridge, and the PCI master and SH7616 share local memory on the SH7616 bus. By using this pin in combination with the $\overline{\text{WAIT}}$ pin, it is possible to place the bus and specific control signals in the high-impedance state while keeping the SH7616's internal state halted. The conditions for establishing the high-impedance state, the applicable pins, and the bus timing (figure 7.57) are shown below. See the Application Note for an example of PCI bridge connection.

- High-impedance conditions: Not dependent on BCR settings etc. when $\overline{\text{WAIT}} = \text{L}$ and $\overline{\text{BUSHiZ}} = \text{L}$
- Applicable pins: A[24:0], D[31:0], $\overline{\text{CS3}}$, RD/WR, $\overline{\text{RD}}$, $\overline{\text{RAS}}$, $\overline{\text{CAS/OE}}$, DQMLL/ $\overline{\text{WE0}}$, DQMLU/ $\overline{\text{WE1}}$, DQMUL/ $\overline{\text{WE2}}$, DQMUU/ $\overline{\text{WE3}}$ (total of 66 pins)

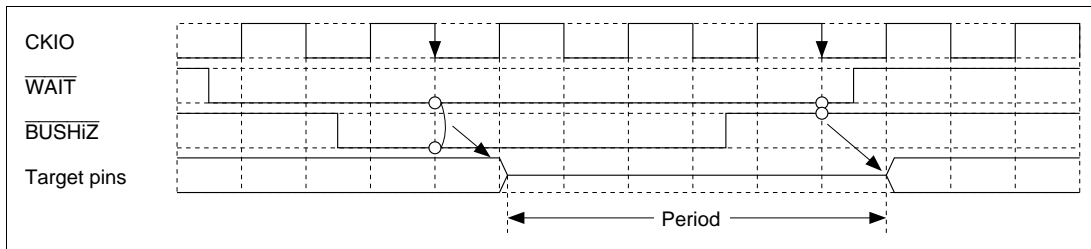

Figure 7.57 $\overline{\text{BUSHiZ}}$ Bus Timing

1. Can be used when memory is shared by the CPU and an external device.
2. When $\overline{\text{BUSHiZ}}$ is asserted after asserting $\overline{\text{WAIT}}$, the CPU appears to release the bus.
3. When it becomes possible to access the shared memory, $\overline{\text{BUSHiZ}}$ is negated.
4. When the data is ready, $\overline{\text{WAIT}}$ is negated.

This procedure allows the CPU and an external device to share memory.

7.11 Usage Notes

7.11.1 Normal Space Access after Synchronous DRAM Write when Using DMAC

Negation of the $\overline{\text{DQMn/WE}}\overline{\text{n}}$ signal in a synchronous DRAM write and $\overline{\text{CSn}}$ assertion in an immediately following normal space access both occur at the same rising edge of CKIO (figure 7.58). As there is a risk of an erroneous write to normal space in this case, when synchronous DRAM or a high-speed device is connected to normal space, it is recommended that $\overline{\text{CSn}}$ be delayed on the system side.

Cases in which a synchronous DRAM write and normal space access occur consecutively are shown in table 7.10.

Table 7.10 access sequence

Write to Synchronous DRAM	Normal Space Access
CPU	DMA
DMA	CPU
DMA	DMA

Note: When an access by the CPU is performed immediately after a write by the CPU, internally the accesses are not consecutive.

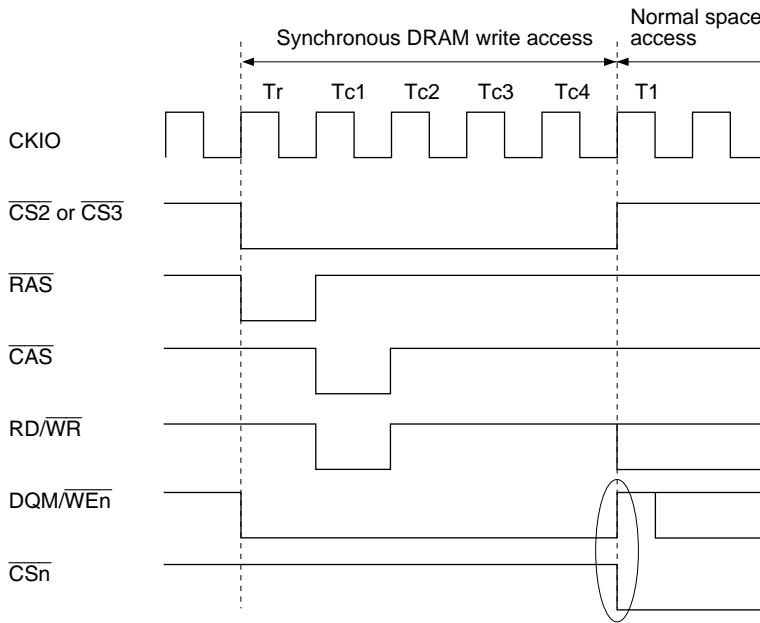

(a) Burst write mode

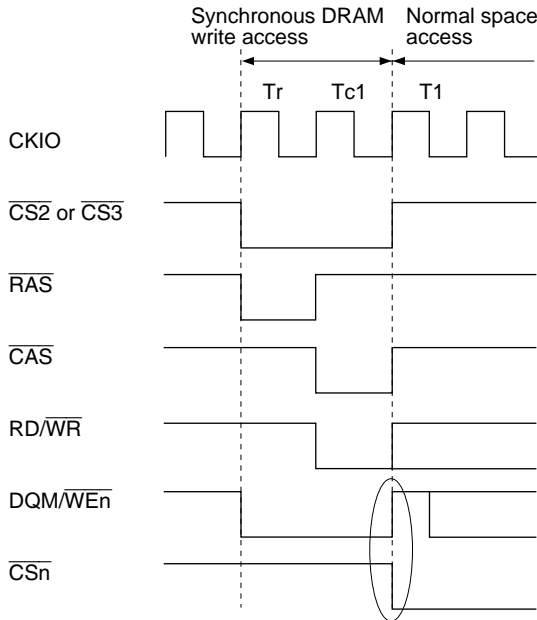

(b) Single write mode

Figure 7.58 Normal Space Access Immediately after Synchronous DRAM Write

7.11.2 When Using $I\phi : E\phi$ Clock Ratio of 1 : 1, 8-Bit Bus Width, and External Wait Input

When using an $I\phi : E\phi$ clock ratio of 1 : 1 and an 8-bit bus width, at least 1.5 address hold cycles should be set.

Set a value other than the initial value in bits AnSHW1, AnSHW0, A4HW1, and A4HW0 for the relevant space.

7.11.3 When connecting external device to synchronous DRAM

When connecting an external device to the synchronous DRAM, not only CSnN and DACKn but also other instructions for the synchronous DRAM such as CSnN, RASN, CASN and RDWRN must be recognized for the estimation of an access sequence.

In some cases, it is difficult to specify read and write cycles only with CSnN and DACKn.

Section 8 Cache

8.1 Introduction

This chip incorporates 4 kbytes of four-way, mixed instruction/data type cache memory. This memory can also be used as 2-kbyte RAM and 2 kbyte mixed instruction/data type cache memory by making a setting in the cache control register (CCR) (two-way cache mode). CCR can specify that either instructions or data do not use cache. Both write-through and write-back modes are supported for cache operation.

Each line of cache memory consists of 16 bytes. Cache memory is always updated in line units. Four 32-bit accesses are required to update a line. Since the number of entries is 64, the six bits (A9 to A4) in each address determine the entry. A four-way set associative configuration is used, so up to four different instructions/data can be stored in the cache even when entry addresses match. To efficiently use four ways having the same entry address, replacement is provided based on a pseudo-LRU (least-recently used) replacement algorithm.

The cache configuration is shown in figure 8.1, and addresses in figure 8.2.

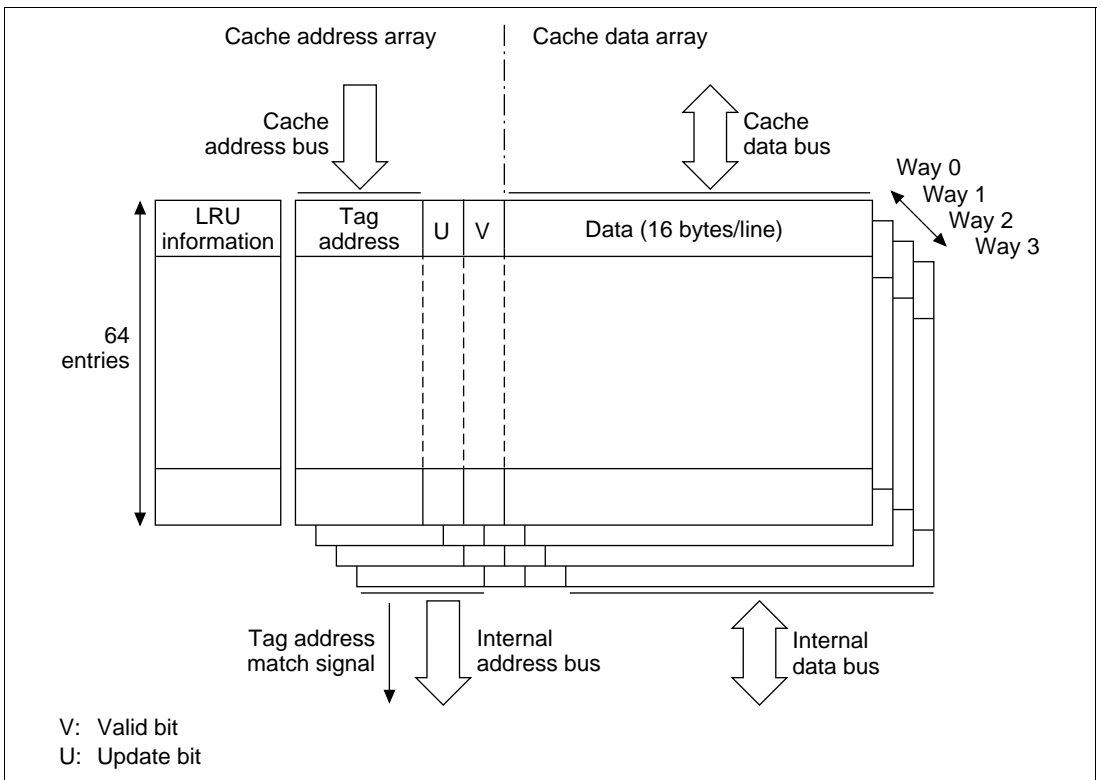

Figure 8.1 Cache Configuration

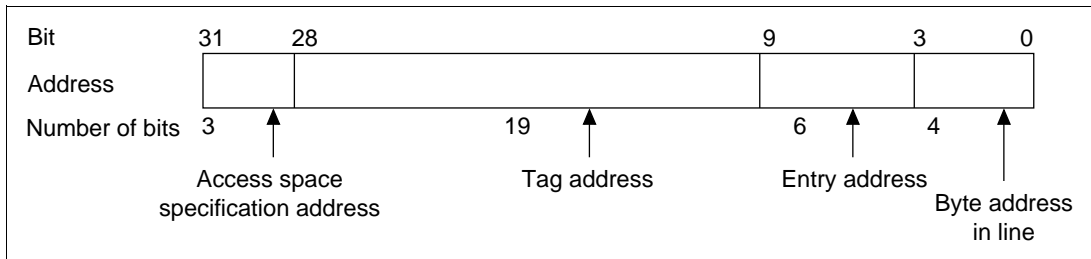

Figure 8.2 Address Configuration

8.1.1 Register Configuration

Table 8.1 shows the cache register configuration.

Table 8.1 Register Configuration

Name	Abbrev.	R/W	Initial Value	Address
Cache control register	CCR	R/W	H'00	H'FFFFFFE92

8.2 Register Description

8.2.1 Cache Control Register (CCR)

The cache control register (CCR) is used for cache control. CCR must be set and the cache must be initialized before use. CCR is initialized to H'00 by a power-on reset or manual reset.

Bit:	7	6	5	4	3	2	1	0
	W1	W0	WB	CP	TW	OD	ID	CE
Initial value:	0	0	0	0	0	0	0	0
R/W:	R/W	R/W	R/W	R/W	R/W	R/W	R/W	R/W

Bits 7 and 6—Way Specification Bit (W1, W0): W1 and W0 specify the way when an address array is directly accessed by address specification.

Bit 7: W1	Bit 6: W0	Description
0	0	Way 0 (Initial value)
	1	Way 1
1	0	Way 2
	1	Way 3

Bit 5—Write-Back Bit (WB): Specifies the cache operation method when the cache area is accessed.

Bit 5: WB	Description
0	Write-through (Initial value)
1	Write-back

Bit 4—Cache Purge Bit (CP): When 1 is written to the CP bit, all cache entries and the valid bits, and LRU information of all ways are initialized to 0. After initialization is completed, the CP bit reverts to 0. The CP bit always reads 0. The CP bit always reads 0.

Bit 4: CP	Description
0	Normal operation (Initial value)
1	Cache purge

Note: Always read 0.

Bit 3—Two-Way Mode (TW): TW is the two-way mode bit. The cache operates as a four-way set associative cache when TW is 0 and as a two-way set associative cache and 2-kbyte RAM when TW is 1. In the two-way mode, ways 2 and 3 are cache and ways 0 and 1 are RAM. Ways 0 and 1 are read or written by direct access of the data array according to address space specification.

Bit 3: TW	Description
0	Four-way mode (Initial value)
1	Two-way mode

Bit 2—Data Replacement Disable Bit (OD): OD is the bit for disabling data replacement. When this bit is 1, data fetched from external memory is not written to the cache even if there is a cache miss. Cache data is, however, read or updated during cache hits. OD is valid only when CE is 1.

Bit 2: OD	Description
0	Normal operation (Initial value)
1	Data not replaced even when cache miss occurs in data access

Bit 1—Instruction Replacement Disable Bit (ID): ID is the bit for disabling instruction replacement. When this bit is 1, an instruction fetched from external memory is not written to the cache even if there is a cache miss. Cache data is, however, read or updated during cache hits. ID is valid only when CE is 1.

Bit 1: ID	Description
0	Normal operation (Initial value)
1	Data not replaced even when cache miss occurs in instruction fetch

Bit 0—Cache Enable Bit (CE): CE is the cache enable bit. Cache can be used when CE is set to 1.

Bit 0: CE	Description
0	Cache disabled (Initial value)
1	Cache enabled

8.3 Address Space and the Cache

The address space is divided into six partitions. The cache access operation is specified by addresses. Table 8.2 lists the partitions and their cache operations. For more information on address spaces, see section 7, Bus State Controller. Note that the spaces of the cache area and cache-through area are the same.

Table 8.2 Address Space and Cache Operation

Addresses A31–A29	Partition	Cache Operation
000	Cache area	Cache is used when the CE bit in CCR is 1
001	Cache-through area	Cache is not used
010	Associative purge area	Cache line of the specified address is purged (disabled)
011	Address array read/write area	Cache address array is accessed directly
110	Data array read/write area	Cache data array is accessed directly
111	I/O area	Cache is not used

8.4 Cache Operation

8.4.1 Cache Reads

This section describes cache operation when the cache is enabled and data is read from the CPU. One of the 64 entries is selected by the entry address part of the address output from the CPU on the cache address bus. The tag addresses of ways 0 through 3 are compared to the tag address parts of the addresses output from the CPU. When there is a way for which the tag address matches, this is called a cache hit (when any one of the way tag addresses and the tag address of the address output from the CPU match). In proper use, the tag addresses of each way differ from each other, and the tag address of only one way will match. When none of the way tag addresses match, it is called a cache miss. Tag addresses of entries with valid bits of 0 will not match in any case.

When a cache hit occurs, data is read from the data array of the way that was matched according to the entry address, the byte address within the line, and the access data size, and is sent to the CPU. The address output on the cache address bus is calculated in the CPU's instruction execution phase and the results of the read are written during the CPU's write-back stage. The cache address bus and cache data bus both operate as pipelines in concert with the CPU's pipeline structure. From address comparison to data read requires 1 cycle; since the address and data operate as a pipeline, consecutive reads can be performed at each cycle with no waits (figure 8.3).

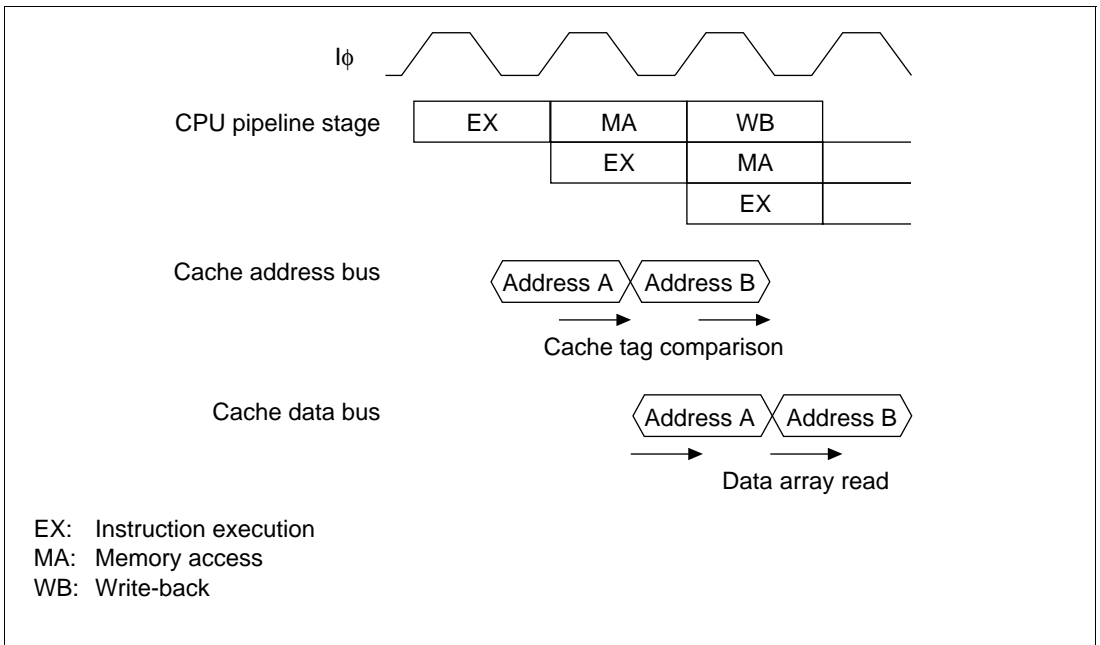

Figure 8.3 Read Access in Case of a Cache Hit

When a cache miss occurs, the way for replacement is determined using the LRU information, and the read address from the CPU is written in the address array for that way. Simultaneously, the valid bit is set to 1. Since the 16 bytes of data for replacing the data array are simultaneously read, the address on the cache address bus is output to the internal address bus and 4 longwords are read consecutively. The access order is such that, for the address output to the internal address bus, the byte address within the line is sequentially incremented by 4, so that the longword that contains the address to be read from the cache comes last. The read data on the internal data bus is written sequentially to the cache data array. One cycle after the last data is written to the cache data array, it is also output to the cache data bus and the read data is sent to the CPU.

The internal address bus and internal data bus also function as pipelines, just like the cache bus (figure 8.4).

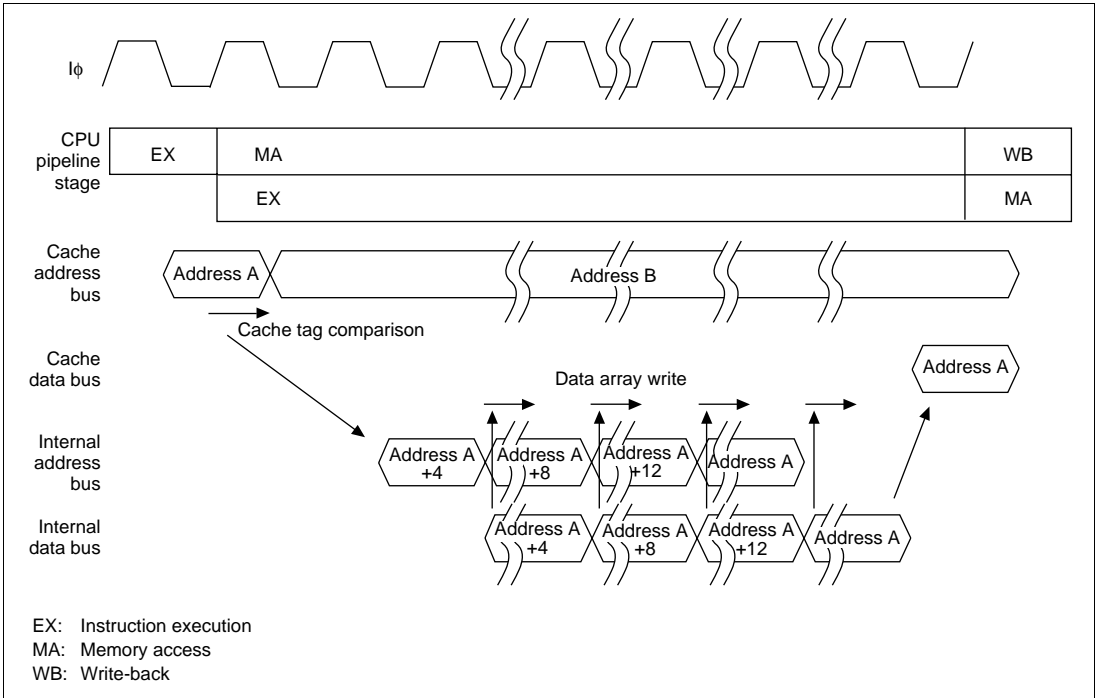

Figure 8.4 Read Access in Case of a Cache Miss

8.4.2 Write Access

Write-Through Mode: Writing to external memory is performed regardless of whether or not there is a cache hit. The write address output to the cache address bus is used for comparison to the tag address of the cache's address array. If they match, the write data output to the cache data bus in the following cycle is written to the cache data array. If they do not match, nothing is written to the cache data array. The write address is output to the internal address bus 1 cycle later than the cache address bus. The write data is similarly output to the internal data bus 1 cycle later than the cache data bus. The CPU waits until the writes on the internal buses are completed (figure 8.5).

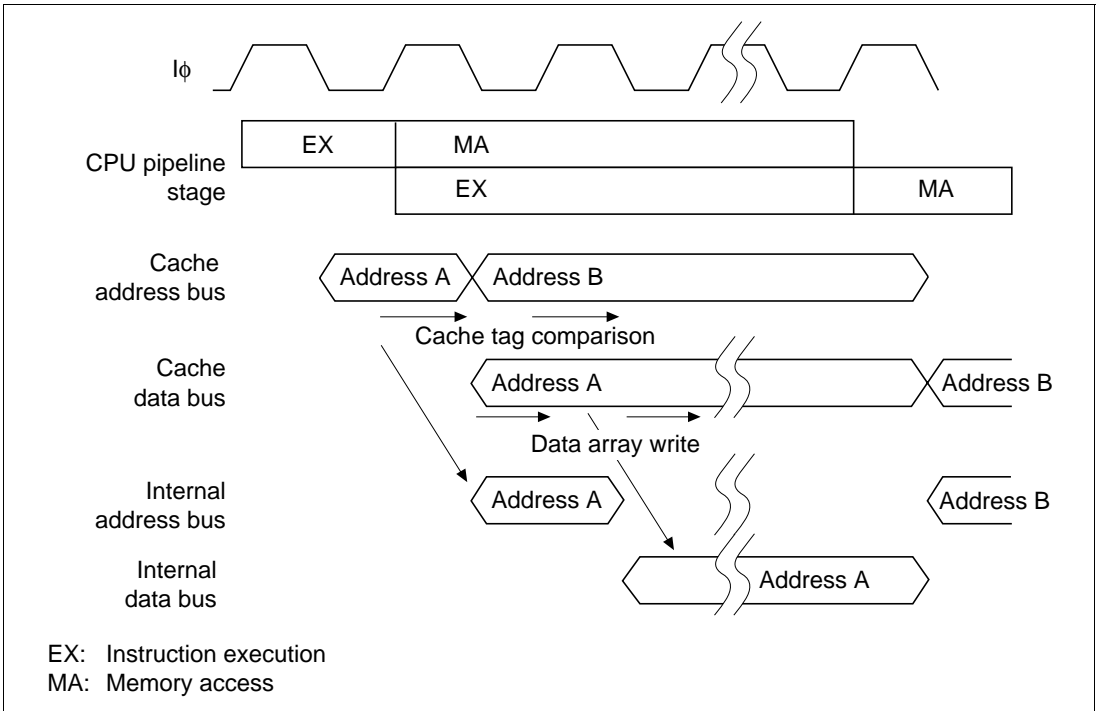

Figure 8.5 Write Access (Write-Through)

Write-Back Mode: When a cache hit occurs, the data is written to the data array of the matching way according to the entry address, byte address in the line, and access data size, and the update bit of that entry is set to 1. A write is performed only to the data array, not to external memory. A write hit is completed in 2 cycles (figure 8.6).

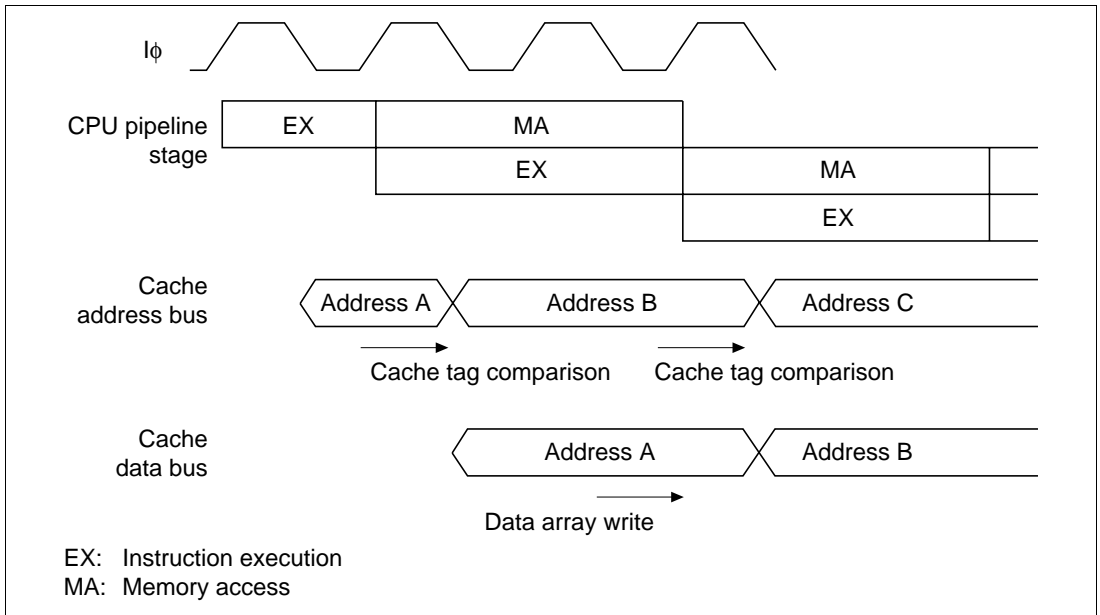

Figure 8.6 Write Access in Case of a Cache Hit (Write-Back)

When a cache miss occurs, the way for replacement is determined using the LRU information, and the write address from the CPU is written in the address array for that way. Simultaneously, the valid bit and update bit are set to 1. Since the 16 bytes of data for replacing the data array are simultaneously read when the data on the cache bus is written to the cache, the address on the cache address bus is output to the internal address bus and 4 longwords are read consecutively. The access order is such that, for the address output to the internal address, the byte address within the line is sequentially incremented by 4, so that the longword that contains the address to be read from the cache comes last. The read data on the internal data bus is written sequentially to the cache data array.

The internal address bus and internal data bus also function as pipelines, just like the cache bus (figure 8.7).

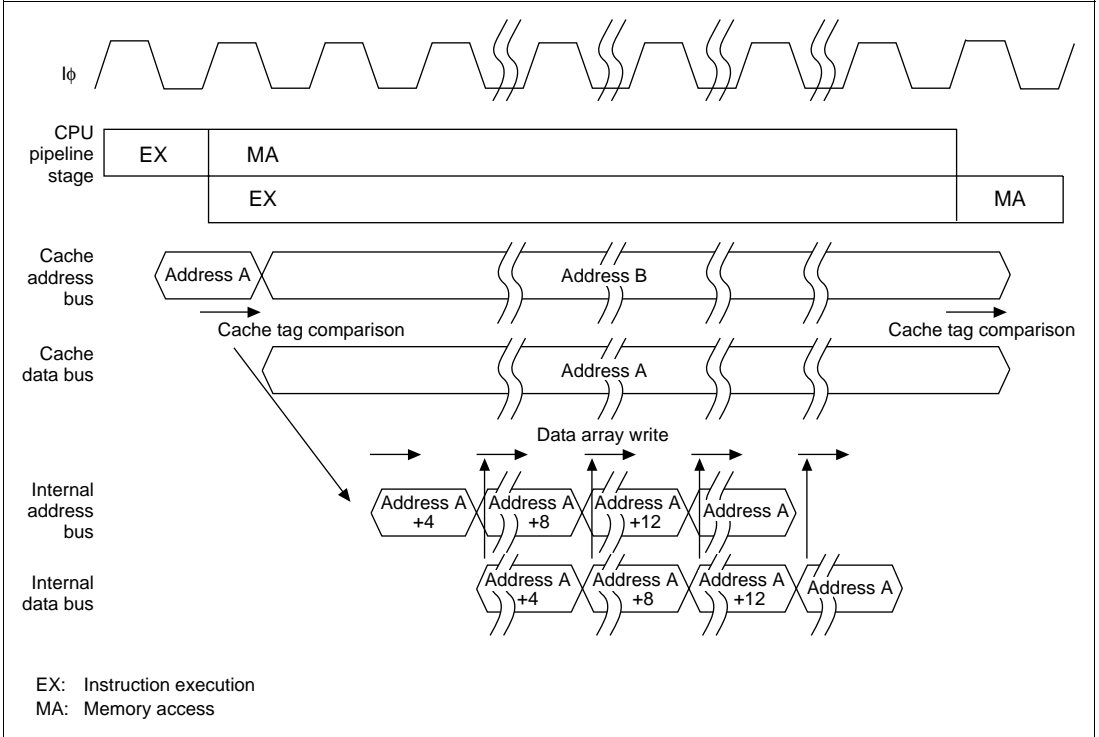

Figure 8.7 Write Access in Case of a Cache Miss (Write-Back)

When the update bit of an entry to be replaced in write-back mode is 1, write-back to external memory is necessary. To improve performance, the entry to be replaced is first transferred to the write-back buffer, and fetching of the new entry into the cache is given priority over the write-back. When the new entry has been fetched into the cache, the write-back buffer contents are written back to external memory. The cache can be accessed during this write-back.

The write-back buffer can hold one cache line (16 bytes) of data and its address. The configuration of the write-back buffer is shown in figure 8.8.

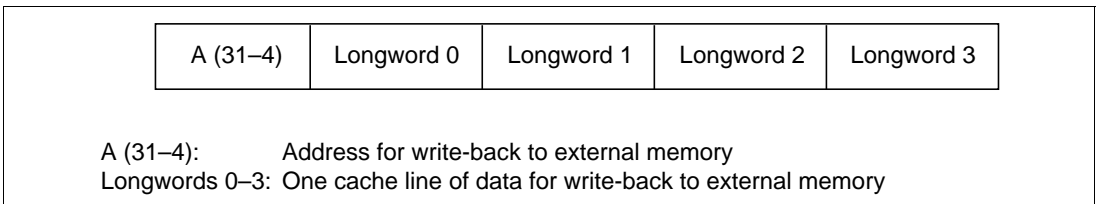

Figure 8.8 Write-Back Buffer Configuration

8.4.3 Cache-Through Access

When reading or writing a cache-through area, the cache is not accessed. Instead, the cache address value is output to the internal address bus. For read operations, the read data output to the internal data bus is fetched and output to the cache data bus, as shown in figure 8.9. The read of the cache-through area is only performed on the address in question. For write operations, the write data on the cache data bus is output to the internal data bus. Writes on the cache through area are compared to the address tag; except for the fact that nothing is written to the data array, the operation is the same as the write shown in figure 8.5.

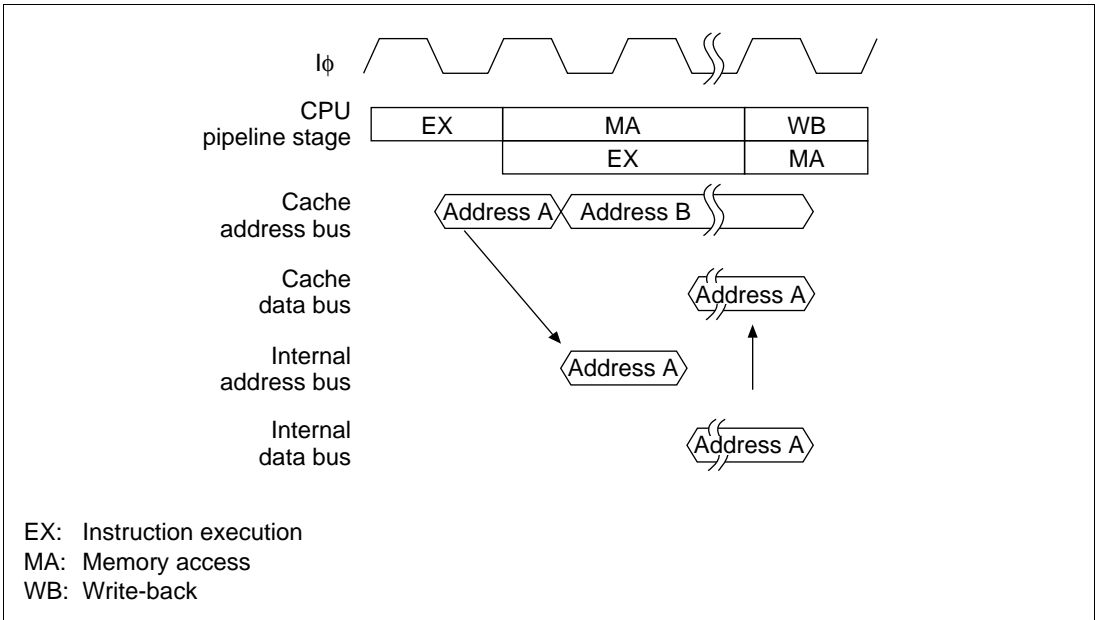

Figure 8.9 Reading Cache-Through Areas

8.4.4 The TAS Instruction

The TAS instruction reads data from memory, compares it to 0, reflects the result in the T bit of the status register (SR), and sets the most significant bit to 1. It is an instruction that writes to the same address. Accesses to the cache area are handled in the same way as ordinary data accesses.

8.4.5 Pseudo-LRU and Cache Replacement

When a cache miss occurs during a read, the data of the missed address is read from 1 line (16 bytes) of memory and replaced. It is therefore necessary to decide which of the four ways is to be replaced. It can generally be expected that a way that has been infrequently used recently is also unlikely to be used next. This algorithm for replacing ways is called the least recently used replacement algorithm, or LRU. The hardware to implement it, however, is complex. For that

reason, this cache uses a pseudo-LRU replacement algorithm that keeps track of the order of way access and replaces the oldest way.

Six bits of data are used as the LRU information. The bits indicate the access order for 2 ways, as shown in figure 8.10. When the value is 1, access occurred in the direction of the appropriate arrow in the figure. The direction of the arrow can be determined by reading the bit. Access to the way to which all the arrows are pointing is the oldest, and that way becomes subject to replacement. The access order is recorded in the LRU information bits, so the LRU information is rewritten when a cache hit occurs during a read, when a cache hit occurs during a write, and when replacement occurs after a cache miss. Table 8.3 shows the rewrite values; table 8.4 shows how the way to be replaced is selected.

After a cache purge by means of the CP bit in CCR, all the LRU information is zeroized, so the initial order of use is way 3 → way 2 → way 1 → way 0. Thereafter, the way is selected according to the order of access in the program. Since the replacement will not be correct if the LRU gets an inappropriate value, the address array write function can be used to rewrite. When this is done, be sure not to write a value other than 0 as the LRU information.

When the OD bit or ID bit in CCR is 1, cache replacement is not performed even if a cache miss occurs during data read or instruction fetch. Instead of replacing, the missed address data is read and directly transferred to the CPU.

The two-way mode of the cache set by CCR's TW bit can only be implemented by replacing ways 2 and 3. Comparisons of address array tag addresses are carried out on all four ways even in two-way mode, so the valid bits of ways 1 and 0 must be cleared to 0 before beginning operation in two-way mode.

Writing for the tag address and valid bit for cache replacement does not wait for the read from memory to be completed. If a memory access is aborted due to a reset, etc., during replacement, there will be a discrepancy between the cache contents and memory contents, so a purge must be performed.

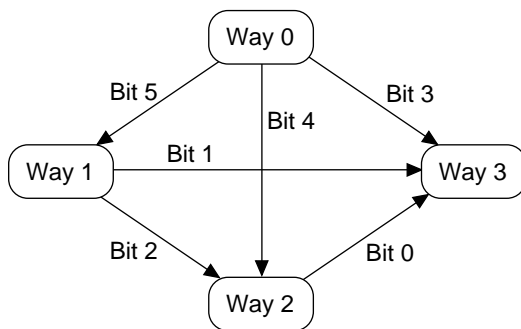

Figure 8.10 LRU Information and Access Sequence

Table 8.3 LRU Information after Update

	Bit 5	Bit 4	Bit 3	Bit 2	Bit 1	Bit 0
Way 0	0	0	0	—	—	—
Way 1	1	—	—	0	0	—
Way 2	—	1	—	1	—	0
Way 3	—	—	1	—	1	1

Note: —: Holds the value before update.

Table 8.4 Selection Conditions for Replaced Way

	Bit 5	Bit 4	Bit 3	Bit 2	Bit 1	Bit 0
Way 0	1	1	1	—	—	—
Way 1	0	—	—	1	1	—
Way 2	—	0	—	0	—	1
Way 3	—	—	0	—	0	0

Note: —: Don't care.

8.4.6 Cache Initialization

Purges of the entire cache area can only be carried out by writing 1 to the CP bit in CCR. Writing 1 to the CP bit initializes the valid bit of the address array, and all bits of the LRU information, to 0. Cache purges are completed in 1 cycle, but additional time is required for writing to CCR. Always initialize the valid bit and LRU before enabling the cache.

When the cache is enabled, instructions are read from the cache even during writing to CCR. This means that the prefetched instructions are read from the cache. To do a proper purge, write 0 to CCR's CE bit, then disable the cache and purge. Since CCR's CE bit is cleared to 0 by a power-on reset or manual reset, the cache can be purged immediately by a reset.

8.4.7 Associative Purges

Associative purges invalidate 1 line (16 bytes) corresponding to specific address contents when the contents are in the cache.

When the contents of a shared address are rewritten by one CPU in a multiprocessor configuration or a configuration in which the chip's internal E-DMAC (or DMAC) and CPU share memory, that address must be invalidated in the cache of the other CPU if it is present there.

When writing to or reading the address obtained by adding H'40000000 to the address to be purged, the valid bit of the entry storing the address prior to addition are initialized to 0.

16 bytes are purged in each write, so a purge of 256 bytes of consecutive areas can be accomplished in 16 writes. Access sizes when associative purges are performed should be longword. A purge of 1 line requires 2 cycles.

Also note that write-back (flushing) to the main memory is not performed if there is a dirty line in the cache.

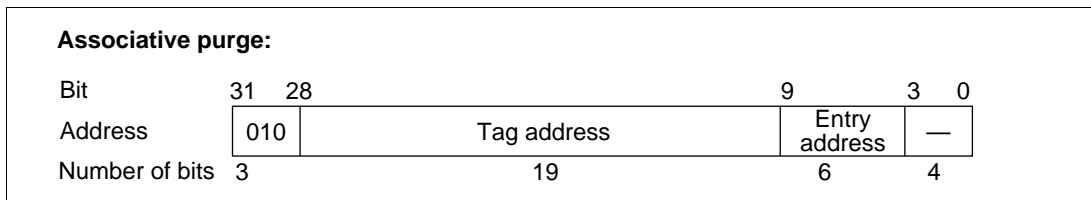

Figure 8.11 Associative Purge Access

8.4.8 Cache Flushing

When the CPU rewrites the contents of a specific shared address in the cache by write-back in a multiprocessor configuration or a configuration in which the chip's internal E-DMAC (or DMAC) and CPU share memory, the rewritten data must be written back to the main memory, and the cache contents invalidated, before the bus is granted by the CPU in the chip to another master (external master, E-DMAC, or DMAC). The chip does not support an instruction or procedure for flushing the contents of specific addresses, so in order to execute a cache flush it is necessary to perform reads in a 4-kbyte space (cache area) other than the address space to be flushed from cache, and intentionally create cache misses. For this purpose, cache accesses should be performed every 16 bytes. By this means, write-backs are generated and the contents written to the cache by the CPU in the chip are written back to the main memory, enabling flushing to be executed. However, this method incurs an overhead consisting of the cache fill time due to read misses and the time for rereading data to be left in the cache. Therefore, if the overhead due to use of the write-back method is of concern when constructing a system in which a number of masters share memory, the shared area should be made a cache-through area in order to maintain coherency.

8.4.9 Data Array Access

The cache data array can be read or written directly via the data array read/write area. Byte, word, or longword access can be used on the data array. Data array accesses are completed in 1 cycle for a read and 2 cycles for a write. Since only the cache bus is used, the operation can proceed in parallel even when another master, such as the DMAC, is using the bus. The data array of way 0 is mapped on H'C0000000 to H'C00003FF, way 1 on H'C0000400 to H'C00007FF, way 2 on H'C0000800 to H'C0000BFF and way 3 on H'C0000C00 to H'C0000FFF. When the two-way mode is being used, the area H'C0000000 to H'C00007FF is accessed as 2 kbytes of on-chip RAM. When the cache is disabled, the area H'C0000000 to H'C0000FFF can be used as 4 kbytes of on-chip RAM.

When the contents of the way being used as cache are rewritten using a data array access, the contents of external memory and cache will not match, so this operation should be avoided.

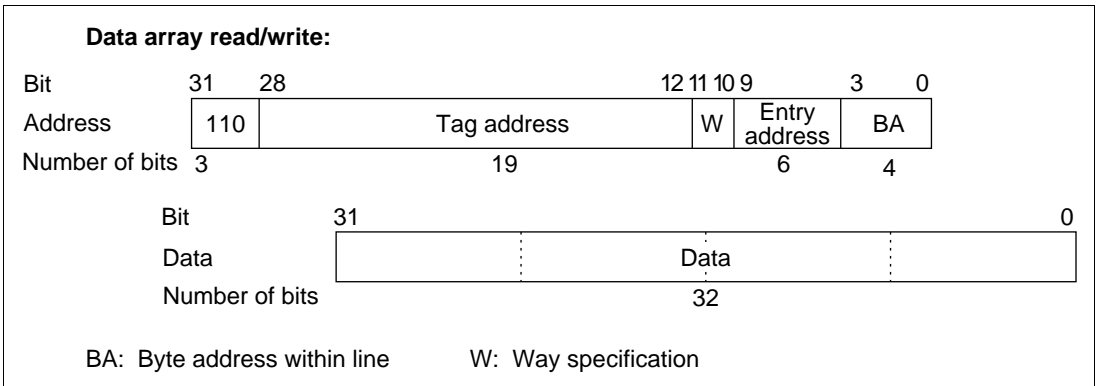

Figure 8.12 Data Array Access

8.4.10 Address Array Access

The address array of the cache can be accessed so that the contents fetched to the cache can be checked for purposes of program debugging or the like. The address array is mapped on H'60000000 to H'600003FF. Since all of the ways are mapped to the same addresses, ways are selected by rewriting the W1 and W0 bits in CCR. The address array can only be accessed in longwords.

When the address array is read, the tag address, LRU information, and valid bit are output as data. When the address array is written to, the tag address, and valid bit are written from the cache address bus. The write address must therefore be calculated before the write is performed. LRU information is written from the cache data bus, but 0 must always be written to prevent malfunctions.

Address array read:

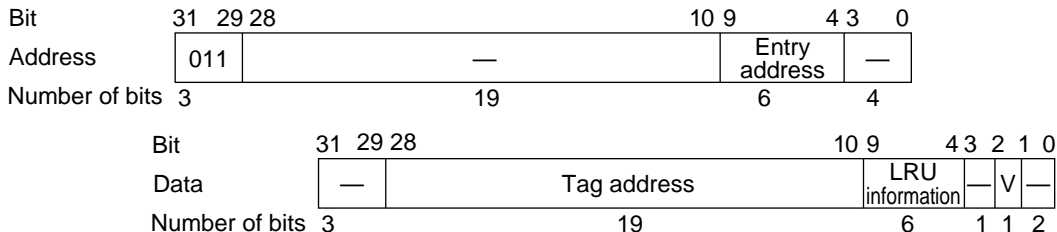

Address array write:

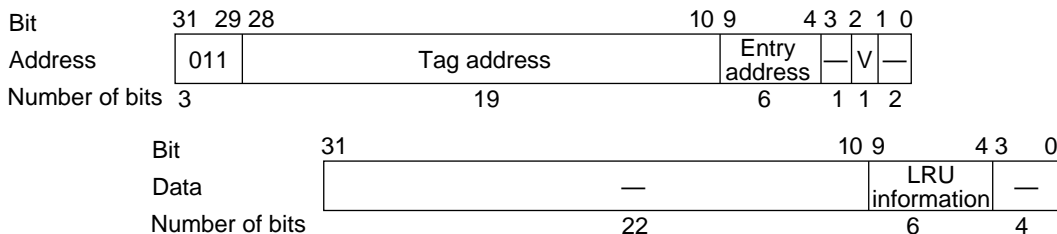

V: Valid bit

Figure 8.13 Address Array Access

8.5 Cache Use

8.5.1 Initialization

Cache memory is not initialized in a reset. Therefore, the cache must be initialized by software before use. The cache is initialized by zeroizing all address array valid bits and LRU information. The address array write function can be used to initialize each line, but it is simpler to initialize it once by writing 1 to the CP bit in CCR. Figure 8.14 shows how to initialize the cache.

```
MOV.W  #H'FE92, R1
MOV.B  @R1, R0    ;
AND    #H'FE, R0  ;
MOV.B  #R0, @R1   ; Cache disable
OR     #H'10, R0
MOV.B  R0, @R1    ; Cache purge
OR     #H'01, R0
MOV.B  R0, R1     ; Cache enable
```

Figure 8.14 Cache Initialization

8.5.2 Purge of Specific Lines

There is no snoop function (for monitoring data rewrites), so specific lines of cache must be purged when the contents of cache memory and external memory differ as a result of an operation. For instance, when a DMA transfer is performed to the cache area, cache lines corresponding to the rewritten address area must be purged. All entries of the cache can be purged by setting the CP bit in CCR to 1. However, it is efficient to purge only specific lines if only a limited number of entries are to be purged.

An associative purge is used to purge specific lines. Since cache lines are 16 bytes long, purges are performed in a 16-byte units. The four ways are checked simultaneously, and only lines holding data corresponding to specified addresses are purged. When addresses do not match, the data at the specified address is not fetched to the cache, so no purge occurs.

```
; Purging 32 bytes from address R3
MOV.L    #H'40000000, R0
XOR      R1, R1
MOV.L    R1, @(R0, R3)
ADD      #16, R3
MOV.L    R1, @(R0, R3)
```

Figure 8.15 Purging Specific Addresses

When it is troublesome to purge the cache after every DMA transfer, it is recommended that the OD bit in CCR be set to 1 in advance. When the OD bit is 1, the cache operates as cache memory only for instructions. However, when data is already fetched into cache memory, specific lines of cache memory must be purged for DMA transfers.

8.5.3 Cache Data Coherency

The cache memory does not have a snoop function. This means that when data is shared with a bus master other than the CPU, software must be used to ensure the coherency of data. For this purpose, the cache-through area can be used, or a cache purge can be performed with program logic using write-through.

When the cache-through area is to be used, the data shared by the bus masters is placed in the cache-through area. This makes it easy to maintain data coherency, since access of the cache-through area does not fetch data into the cache. When the shared data is accessed repeatedly and the frequency of data rewrites is low, a lower access speed can adversely affect performance.

To purge the cache using program logic, the data updates are detected by the program flow and the cache is then purged. For example, if the program inputs data from a disk, whenever reading of a unit (such as a sector) is completed, the buffer address used for reading or the entire cache is

purged, thereby maintaining coherency. When data is to be exchanged between two processors, only flags that provide mutual notification of completion of data preparation or completion of a fetch are placed in the cache-through area. The data actually to be transferred is placed in the cache area and the cache is purged before the first data read to maintain the coherency of the data. When semaphores are used as the means of communication, data coherency can be maintained even when the cache is not purged by utilizing the TAS instruction. Direct external access must always be used for a TAS instruction read.

When the update unit is small, specific addresses can be purged, so only the relevant addresses are purged. When the update unit is larger, it is faster to purge the entire cache rather than purging all the addresses in order, and then read the data that previously existed in the cache again from external memory.

When write-back is used, coherency can be maintained by executing write-backs (flushing) to memory by means of intentional cache miss reads, but since executing flushing incurs an overhead, use of write-through or accessing the cache-through area is recommended in a system in which a number of masters share memory.

8.5.4 Two-Way Cache Mode

The 4-kbyte cache can be used as 2-kbyte RAM and 2-kbyte mixed instruction/data cache memory by setting the TW bit in CCR to 1. Ways 2 and 3 become cache, and ways 0 and 1 become RAM.

Initialization is performed by writing 1 to the CP bit in CCR, in the same way as with 4 ways. The valid bit, and LRU bits are cleared to 0.

When LRU information is initialized to zero, the initial order of use is way 3 → way 2. Thereafter, way 3 or way 2 is selected for replacement in accordance with the LRU information. The conditions for updating the LRU information are the same as for four-way mode, except that the number of ways is two.

When designated as 2-kbyte RAM, ways 0 and 1 are accessed by data array access. Figure 8.16 shows the address mapping.

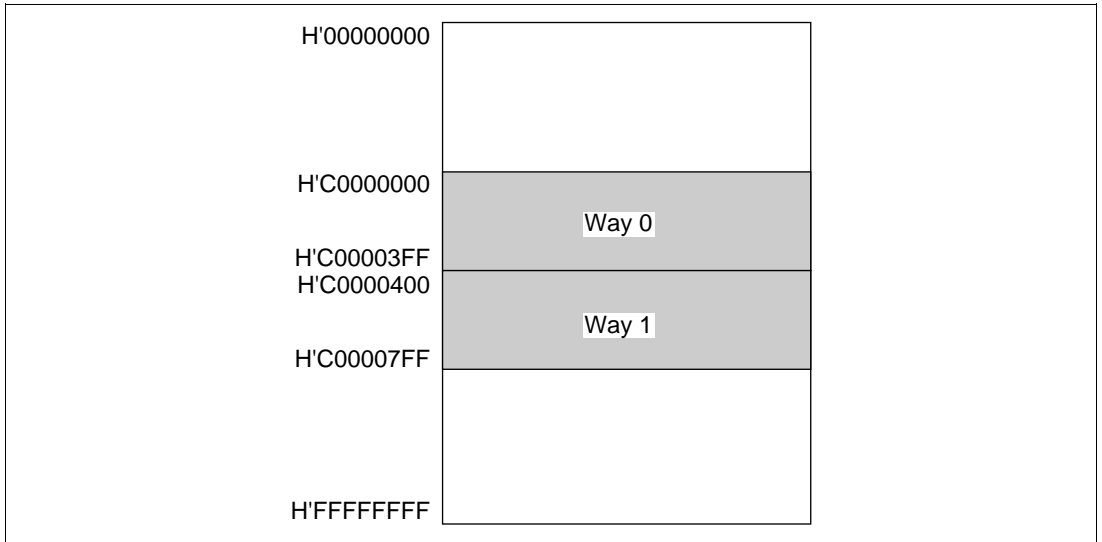

Figure 8.16 Address Mapping of 2-kbyte RAM in the Two-Way Mode

8.6 Usage Notes

8.6.1 Standby

Disable the cache before entering the standby mode for power-down operation. After returning from standby, initialize the cache before use.

8.6.2 Cache Control Register

Changing the contents of CCR also changes cache operation. The chip makes full use of pipeline operations, so it is difficult to synchronize access. For this reason, change the contents of the cache control register simultaneously when disabling the cache or after the cache is disabled. After changing the CCR contents, perform a CCR read.

Section 9 Ethernet Controller (EtherC)

9.1 Overview

The SH7616 has an on-chip Ethernet controller (EtherC) conforming to the IEEE802.3 MAC (Media Access Control) layer standard. Connecting a physical-layer LSI (PHY-LSI) complying with this standard enables the Ethernet controller (EtherC) to perform transmission and reception of Ethernet/IEEE802.3 frames. The Ethernet controller is connected to dedicated transmit and receive Ethernet DMACs (E-DMACs) in the SH7616, and carries out high-speed data transfer to and from memory.

9.1.1 Features

The EtherC has the following features:

- Transmission and reception of Ethernet/IEEE802.3 frames
- Supports 10/100 Mbps transfer
- Supports full-duplex and half-duplex modes
- Conforms to IEEE802.3u standard MII (Media Independent Interface)
- Magic Packet detection and Wake On LAN (WOL) signal output
- CAM (Content Addressable Memory) match signal input function

9.1.2 Configuration

Figure 9.1 shows the configuration of the Ethernet controller.

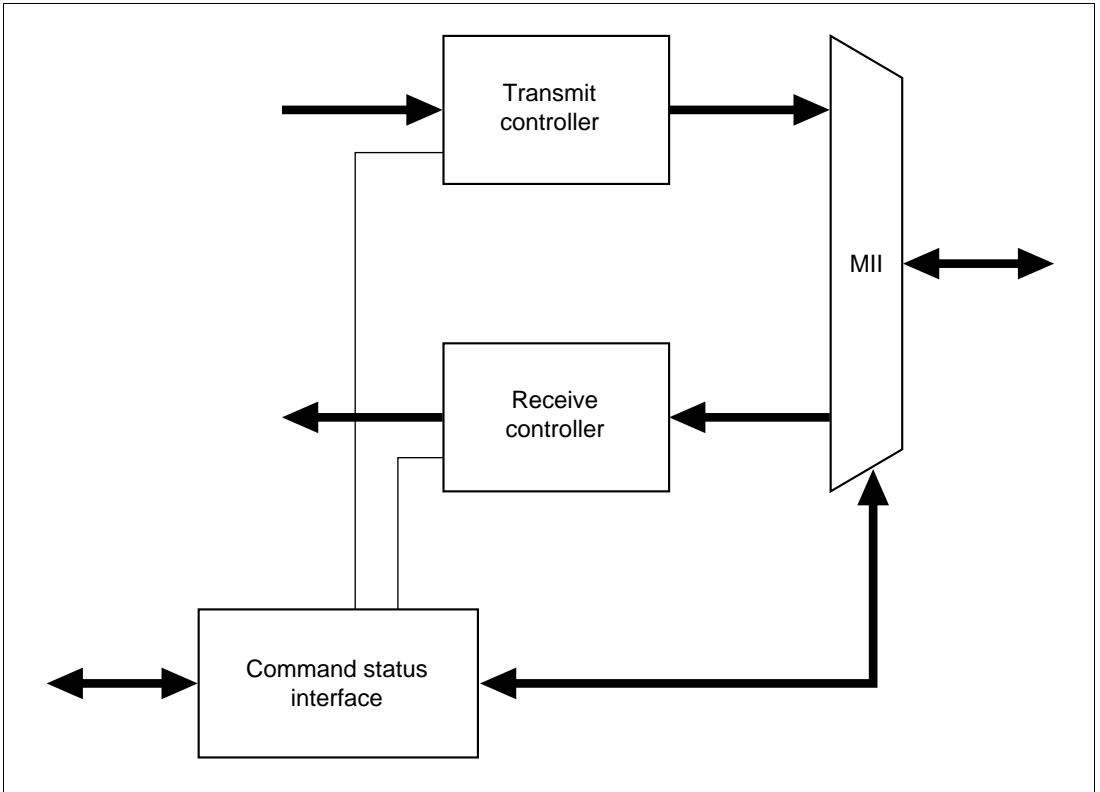

Figure 9.1 Configuration of Ethernet Controller (EtherC)

Transmit Controller: Transmit data is stored in the transmit FIFO from memory via the transmit E-DMAC. The transmit controller assembles this data into an Ethernet/IEEE802.3 frame, which it outputs to the MII. After passing through the MII, the transmit data is sent onto the line by a PHY-LSI. The main functions of the transmit controller are as follows:

- Frame assembly and transmission
- CRC calculation and provision to frames
- Data retransmission in case of a collision (up to 15 times)
- Compliant with MII in IEEE802.3u standard
- Byte-nibble conversion supporting PHY-LSI speed

Receive Controller: After a frame is received via the MII, the receive controller carries out address information, frame length, CRC, and other checks, and the receive data is transferred to memory by the receive E-DMAC. The main functions of the receive controller are as follows:

- Checking received frame format
- Checking receive frame CRC and frame length
- Transfer of own-address, multicast, or broadcast receive frames to memory
- Compliant with MII in IEEE802.3u standard
- Nibble-byte conversion supporting PHY-LSI speed
- Magic Packet monitoring
- CAM (Content Addressable Memory) match signal input function

Command/Status Interface: This interface provides various command/status registers to control the EtherC, and performs access to PHY-LSI internal registers via the MII.

9.1.3 Pin Configuration

The EtherC has signal pins compatible with the 18-pin MII specified in the IEEE802.3u standard, and three related signal pins to simplify connection to the PHY-LSI. The pin configuration are shown in table 9.1.

Table 9.1 MII Pin Functions

Type	Abbreviation	Name	I/O	Function
MII	TX-CLK	Transmit clock	Input	TX-EN, ETXD0 to ETXD3, TX-ER timing reference signal
	RX-CLK	Receive clock	Input	RX-DV, ERXD0 to ERXD3, RX-ER timing reference signal
	TX-EN	Transmit enable	Output	Indicates that transmit data is ready on ETXD0 to ETXD3
	ETXD0–ETXD3	Transmit data (4-bit)	Output	4-bit transmit data
	TX-ER	Transmit error	Output	Notifies PHY-LSI of error during transmission
	RX-DV	Receive data valid	Input	Indicates that there is valid receive data on ERXD0 to ERXD3
	ERXD0–ERXD3	Receive data (4-bit)	Input	4-bit receive data
	RX-ER	Receive error	Input	Identifies error state occurring during data reception
	CRS	Carrier detect	Input	Carrier detection signal
	COL	Collision detect	Input	Collision detection signal
	MDC	Management data clock	Output	Reference clock signal for information transfer via MDIO
	MDIO	Management data input/output	Input/output	Bidirectional signal for exchange of management information between STA and PHY
Other	LNKSTA	Link status	Input	Inputs link status from PHY-LSI
	EXOUT	General-purpose external output	Output	External output pin
	WOL	Wake-On-LAN	Output	Magic packet reception
	CAMSEN	CAM input	Input	CAM match signal input function

9.1.4 Ethernet Controller Register Configuration

The Ethernet controller (EtherC) has the nineteen 32-bit registers shown in table 9.2.

Table 9.2 EtherC Registers

Name	Abbreviation	R/W	Initial Value	Address
EtherC mode register	ECMR	R/W	H'00000000	H'FFFFFFD60
EtherC status register	ECSR	R/W* ¹	H'00000000	H'FFFFFFD64
EtherC interrupt permission register	ECSIPR	R/W	H'00000000	H'FFFFFFD68
PHY interface register	PIR	R/W	H'0000000X	H'FFFFFFD6C
MAC address high register	MAHR	R/W	H'00000000	H'FFFFFFD70
MAC address low register	MALR	R/W	H'00000000	H'FFFFFFD74
Receive frame length register	RFLR	R/W	H'00000000	H'FFFFFFD78
PHY status register	PSR	R	H'00000000	H'FFFFFFD7C
Transmit retry over counter register	TROCR	R/W* ²	H'00000000	H'FFFFFFD80
Single Collision detect counter register	SCDCR	R/W* ²	H'00000000	H'FFFFFFDB4
Delay Collision detect counter register	CDCR	R/W* ²	H'00000000	H'FFFFFFD84
Lost carrier counter register	LCCR	R/W* ²	H'00000000	H'FFFFFFD88
Carrier not detect counter register	CNDCR	R/W* ²	H'00000000	H'FFFFFFD8C
Illegal frame length counter register	IFLCR	R/W* ²	H'00000000	H'FFFFFFD90
CRC error frame receive counter register	CEFCR	R/W* ²	H'00000000	H'FFFFFFD94
Frame receive error counter register	FRECR	R/W* ²	H'00000000	H'FFFFFFD98
Too-short frame receive counter register	TSFRCR	R/W* ²	H'00000000	H'FFFFFFD9C
Too-long frame receive counter register	TLFRCR	R/W* ²	H'00000000	H'FFFFFFDA0
Residual-bit frame counter register	RFCR	R/W* ²	H'00000000	H'FFFFFFDA4
Multicast address frame counter register	MAFCR	R/W* ²	H'00000000	H'FFFFFFDA8

Notes: 1. All registers must be accessed as 32-bit units.

2. Reserved bits in a register should only be written with 0.

3. The value read from a reserved bit is not guaranteed.

*1 Individual bits are cleared by writing 1.

*2 Cleared by a write to the register.

9.2 Register Descriptions

9.2.1 EtherC Mode Register (ECMR)

Bit:	31	30	29	...	19	18	17	16
	—	—	—	...	—	—	—	—
Initial value:	0	0	0	...	0	0	0	0
R/W:	R	R	R	...	R	R	R	R
Bit:	15	14	13	12	11	10	9	8
	—	—	—	PRCEF	—	—	MPDE	—
Initial value:	0	0	0	0	0	0	0	0
R/W:	R	R	R	R/W	R	R	R/W	R
Bit:	7	6	5	4	3	2	1	0
	—	RE	TE	—	ILB	ELB	DM	PRM
Initial value:	0	0	0	0	0	0	0	0
R/W:	R	R/W	R/W	R	R/W	R/W	R/W	R/W

The EtherC mode register specifies the operating mode of the Ethernet controller. The settings in this register are normally made in the initialization process following a reset.

Notes: Operation mode settings must not be changed while the transmitting and receiving functions are enabled. To modify bits other than the ECMR's RE and TE bits, follow the procedures below.

1. Return EtherC and E-DMAC to their initial state by means of the software reset bit (SWR) in the E-DMAC mode register (EDMR), and make new settings.
2. Set the RE and TE bits to 0 to disable them before modifying bits. Since a frame may be transmitted or received, wait for at least a maximum frame transfer time before changing bits other than the RE and TE bits.

Bits 31 to 13—Reserved: These bits are always read as 0. The write value should always be 0.

Bit 12—Permit Receive CRC Error Frame (PRCEF): Specifies the treatment of a receive frame containing a CRC error.

Bit 12: PRCEF	Description
0	Reception of a frame with a CRC error is treated as an error (Initial value)
1	Reception of a frame with a CRC error is not treated as an error

Note: When this bit is set to 1, the CRC error frame counter register (CEFCR: see section 9.2.14) is not incremented when a CRC error is detected.

Bits 11 and 10—Reserved: These bits are always read as 0. The write value should always be 0.

Bit 9—Magic Packet Detection Enable (MPDE): Enables or disables Magic Packet detection by hardware to allow activation from the Ethernet. When the Magic Packet is detected, it is reflected to the EtherC status register and the WOL pin notifies peripheral LSIs that the Magic Packet has been received.

Bit 9: MPDE	Description
0	Magic Packet detection is not enabled (Initial value)
1	Magic Packet detection is enabled

Bits 8 and 7—Reserved: These bits are always read as 0. The write value should always be 0.

Bit 6—Receiver Enable (RE): Enables or disables the receiver.

Bit 6: RE	Description
0	Receiver is disabled (Initial value)
1	Receiver is enabled

Note: If a switch is made from the receiver-enabled state (RE = 1) to the receiver-disabled state (RE = 0) while a frame is being received, the receiver will not be disabled until reception of the frame is completed.

Bit 5—Transmitter Enable (TE): Enables or disables the transmitter.

Bit 5: TE	Description
0	Transmitter is disabled (Initial value)
1	Transmitter is enabled

Note: If a switch is made from the transmitter-enabled state (TE = 1) to the transmitter-disabled state (TE = 0) while a frame is being transmitted, the transmitter will not be disabled until transmission of the frame is completed.

Bit 4—Reserved: This bit is always read as 0. The write value should always be 0.

Bit 3—Internal Loop Back Mode (ILB): Specifies loopback mode in the EtherC.

Bit 3: ILB	Description
0	Normal data transmission/reception is performed (Initial value)
1	Data loopback is performed inside the EtherC

Note: A loopback mode specification can only be made with full-duplex transfer (DM = 1 in this register).

Bit 2—External Loop Back Mode (ELB): The value in this register is output directly to the SH7616's general-purpose external output pin (EXOUT). This is used for loopback mode directives, etc., in the PHY-LSI, using the EXOUT pin.

Bit 2: ELB	Description
0	Low-level output from EXOUT pin (Initial value)
1	High-level output from EXOUT pin

Note: In order for PHY loopback to be implemented using this function, the PHY-LSI must have a pin corresponding to the EXOUT pin.

Bit 1—Duplex Mode (DM): Specifies the EtherC transfer method.

Bit 1: DM	Description
0	Half-duplex transfer is specified (Initial value)
1	Full-duplex transfer is specified

Note: When internal loopback mode is specified (ILB = 1), full-duplex transfer (DM = 1) must be used.

Bit 0—Promiscuous Mode (PRM): Setting this bit enables all Ethernet frames to be received.

Bit 0: PRM	Description
0	EtherC performs normal operation (Initial value)
1	EtherC performs promiscuous mode operation

Note: "All Ethernet frames" means all receivable frames, irrespective of differences or enabled/disabled status (destination address, broadcast address, multicast bit, etc.).

9.2.2 EtherC Status Register (ECSR)

Bit:	31	30	29	...	11	10	9	8
	—	—	—	...	—	—	—	—
Initial value:	0	0	0	...	0	0	0	0
R/W:	R	R	R	...	R	R	R	R
Bit:	7	6	5	4	3	2	1	0
	—	—	—	—	—	LCHNG	MPD	ICD
Initial value:	0	0	0	0	0	0	0	0
R/W:	R	R	R	R	R	R/W*	R/W*	R/W*

Note: * The flag is cleared by writing 1. Writing 0 does not affect the flag.

The EtherC status register shows the internal status of the EtherC. This status information can be reported to the CPU by means of interrupts. Individual bits are cleared by writing 1 to them. For bits that generate an interrupt, the interrupt can be enabled or disabled by means of the corresponding bit in the EtherC status interrupt permission register (ECSIPR).

Bits 31 to 3—Reserved: These bits are always read as 0. The write value should always be 0.

Bit 2—LINK Signal Changed (LCHNG): Indicates that the LNKSTA signal input from the PHY-LSI has changed from high to low, or from low to high. This bit is cleared by writing 1 to it. Writing 0 to this bit has no effect.

Bit 2: LCHNG	Description
0	LNKSTA signal change has not been detected (Initial value)
1	LNKSTA signal change (high-to-low or low-to-high) has been detected

- Notes:
1. The current link status can be checked by referencing the LMON bit in the PHY interface status register (PSR).
 2. Signal variation may be detected when the LNKSTA function is selected by the port A control register (PACR) of the pin function controller (PFC).

Bit 1—Magic Packet Detection (MPD): Indicates that a Magic Packet has been detected on the line. This bit is cleared by writing 1 to it. Writing 0 to this bit has no effect.

Bit 1: MPD	Description
0	Magic Packet has not been detected (Initial value)
1	Magic Packet has been detected

Bit 0—Illegal Carrier Detection (ICD): Indicates that PHY-LSI has detected an illegal carrier on the line. This bit is cleared by writing 1 to it. Writing 0 to this bit has no effect.

Bit 0: ICD	Description
0	PHY-LSI has not detected an illegal carrier on the line (Initial value)
1	PHY-LSI has detected an illegal carrier on the line

Note: If a change in the signal input from the PHY-LSI occurs before the software recognition period, the correct information may not be obtained. Refer to the timing specification for the PHY-LSI used.

9.2.3 EtherC Interrupt Permission Register (ECSIPR)

Bit:	31	30	29	...	11	10	9	8
	—	—	—	...	—	—	—	—
Initial value:	0	0	0	...	0	0	0	0
R/W:	R	R	R	...	R	R	R	R
Bit:	7	6	5	4	3	2	1	0
	—	—	—	—	—	LCHNGIP	MPDIP	ICDIP
Initial value:	0	0	0	0	0	0	0	0
R/W:	R	R	R	R	R	R/W	R/W	R/W

This register enables or disables the interrupt sources indicated by the EtherC status register. Each bit in this register enables or disables the interrupt indicated by the corresponding bit in the EtherC status register.

Bits 31 to 3—Reserved: These bits are always read as 0. The write value should always be 0.

Bit 2—LINK Signal Changed Interrupt Permission (LCHNGIP): Controls interrupt notification by the LINK Signal Changed bit.

Bit 2: LCHNGIP	Description
0	Interrupt notification by LCHNG bit in ECSR is disabled (Initial value)
1	Interrupt notification by LCHNG bit in ECSR is enabled

Bit 1—Magic Packet Detection Interrupt Permission (MPDIP): Controls interrupt notification by the Magic Packet Detection bit.

Bit 1: MPDIP	Description
0	Interrupt notification by MPD bit in ECSR is disabled (Initial value)
1	Interrupt notification by MPD bit in ECSR is enabled

Bit 0—Illegal Carrier Detection Interrupt Permission (ICDIP): Controls interrupt notification by the Illegal Carrier Detection bit.

Bit 0: ICDIP	Description
0	Interrupt notification by ICD bit in ECSR is disabled (Initial value)
1	Interrupt notification by ICD bit in ECSR is enabled

9.2.4 PHY Interface Register (PIR)

Bit:	31	30	29	...	11	10	9	8
	—	—	—	...	—	—	—	—
Initial value:	0	0	0	...	0	0	0	0
R/W:	R	R	R	...	R	R	R	R
Bit:	7	6	5	4	3	2	1	0
	—	—	—	—	MDI	MDO	MMD	MDC
Initial value:	0	0	0	0	*	0	0	0
R/W:	R	R	R	R	R	R/W	R/W	R/W

Note: * Undefined

PIR provides a means of accessing PHY-LSI internal registers via the MII.

Bits 31 to 4—Reserved: These bits are always read as 0. The write value should always be 0.

Bit 3— MII Management Data-In (MDI): Indicates the level of the MDIO pin.

Bit 2— MII Management Data-Out (MDO): Outputs the value set to this bit by the MDIO pin when the MMD bit is 1.

Bit 1— MII Management Mode (MMD): Specifies the data read/write direction with respect to the MII. Read direction is indicated by 0, and write direction by 1.

Bit 0— MII Management Data Clock (MDC): Outputs the value set to this bit by the MDC pin and supplies the MII with the management data clock.

For the method of accessing MII registers, see section 9.3.4, Accessing MII Registers.

9.2.5 MAC Address High Register (MAHR)

Bit:	31	30	29	28	27	26	25	24
	MA47	MA46	MA45	MA44	MA43	MA42	MA41	MA40
Initial value:	0	0	0	0	0	0	0	0
R/W:	R/W	R/W	R/W	R/W	R/W	R/W	R/W	R/W
Bit:	23	22	21	20	19	18	17	16
	MA39	MA38	MA37	MA36	MA35	MA34	MA33	MA32
Initial value:	0	0	0	0	0	0	0	0
R/W:	R/W	R/W	R/W	R/W	R/W	R/W	R/W	R/W
Bit:	15	14	13	12	11	10	9	8
	MA31	MA30	MA29	MA28	MA27	MA26	MA25	MA24
Initial value:	0	0	0	0	0	0	0	0
R/W:	R/W	R/W	R/W	R/W	R/W	R/W	R/W	R/W
Bit:	7	6	5	4	3	2	1	0
	MA23	MA22	MA21	MA20	MA19	MA18	MA17	MA16
Initial value:	0	0	0	0	0	0	0	0
R/W:	R/W	R/W	R/W	R/W	R/W	R/W	R/W	R/W

The upper 32 bits of the 48-bit MAC address are set in MARH. The setting in this register is normally made in the initialization process after a reset.

Note: The MAC address setting must not be changed while the transmitter and receiver are enabled. First return the EtherC and E-DMAC modules to their initial state by means of the SWR bit in the E-DMAC mode register (EDMR), then make the new setting.

Bits 31 to 0—MAC Address Bits 47 to 16 (MA47 to MA16): Used to set the upper 32 bits of the MAC address.

Note: If the MAC address to be set in the SH7616 is 01-23-45-67-89-AB (hexadecimal), the value set in this register is H'01234567.

9.2.6 MAC Address Low Register (MALR)

Bit:	31	30	29	...	19	18	17	16
	—	—	—	...	—	—	—	—
Initial value:	0	0	0	...	0	0	0	0
R/W:	R	R	R		R	R	R	R

Bit:	15	14	13	12	11	10	9	8
	MA15	MA14	MA13	MA12	MA11	MA10	MA9	MA8
Initial value:	0	0	0	0	0	0	0	0
R/W:	R/W	R/W	R/W	R/W	R/W	R/W	R/W	R/W

Bit:	7	6	5	4	3	2	1	0
	MA7	MA6	MA5	MA4	MA3	MA2	MA1	MA0
Initial value:	0	0	0	0	0	0	0	0
R/W:	R/W	R/W	R/W	R/W	R/W	R/W	R/W	R/W

The lower 16 bits of the 48-bit MAC address are set in MARL. The setting in this register is normally made in the initialization process after a reset.

Note: The MAC address setting must not be changed while the transmitter and receiver are enabled. First return the EtherC and E-DMAC modules to their initial state by means of the SWR bit in the E-DMAC mode register (EDMR), then make the new setting.

Bits 31 to 16—Reserved: These bits are always read as 0. The write value should always be 0.

Bits 15 to 0—MAC Address Bits 15 to 0 (MA15 to MA0): Used to set the lower 16 bits of the MAC address.

Note: If the MAC address to be set in the SH7616 is 01-23-45-67-89-AB (hexadecimal), the value set in this register is H'000089AB.

9.2.7 Receive Frame Length Register (RFLR)

Bit:	31	30	29	...	19	18	17	16
	—	—	—	...	—	—	—	—
Initial value:	0	0	0	...	0	0	0	0
R/W:	R	R	R	...	R	R	R	R
Bit:	15	14	13	12	11	10	9	8
	—	—	—	—	RFL11	RFL10	RFL9	RFL8
Initial value:	0	0	0	0	0	0	0	0
R/W:	R	R	R	R	R/W	R/W	R/W	R/W
Bit:	7	6	5	4	3	2	1	0
	RFL7	RFL6	RFL5	RFL4	RFL3	RFL2	RFL1	RFL0
Initial value:	0	0	0	0	0	0	0	0
R/W:	R/W	R/W	R/W	R/W	R/W	R/W	R/W	R/W

This register specifies the maximum frame length (in bytes) that can be received by the SH7616

Bits 31 to 12—Reserved: These bits are always read as 0. The write value should always be 0.

Bits 11 to 0—Receive Frame Length (RFL)

H'000–H'5EE	1,518 bytes
H'5EF	1,519 bytes
H'5F0	1,520 bytes
⋮	⋮
H'7FF	2,047 bytes
H'800–H'FFF	2,048 bytes

Notes: 1. The frame length refers to all fields from the destination address up to and including the CRC data.

2. When data that exceeds the specified value is received, the part of the data that is higher than the specified value is discarded.

Frame contents from the destination address up to and including the data are actually transferred to memory. CRC data is not included in the transfer.

9.2.8 PHY Interface Status Register (PSR)

Bit:	31	30	29	...	11	10	9	8
	—	—	—	...	—	—	—	—
Initial value:	0	0	0	...	0	0	0	0
R/W:	R	R	R	...	R	R	R	R
Bit:	7	6	5	4	3	2	1	0
	—	—	—	—	—	—	—	LMON
Initial value:	0	0	0	0	0	0	0	0
R/W:	R	R	R	R	R	R	R	R

PSR enables interface signals from the PHY-LSI to be read.

Bits 31 to 1—Reserved: These bits are always read as 0. The write value should always be 0.

Bit 0—Link Monitor (LMON): The link status can be read by connecting the LINK signal output from the PHY-LSI. For information on the polarity, refer to the specifications for the PHY-LSI to be connected.

Note: The LMON bit is set to 0 when the LNKSTA pin is at high level, and it is set to 1 when the LNKSTA pin is at low level.

9.2.9 Transmit Retry Over Counter Register (TROCR)

Bit:	31	30	29	...	19	18	17	16
	—	—	—	...	—	—	—	—
Initial value:	0	0	0	...	0	0	0	0
R/W:	R	R	R	...	R	R	R	R
Bit:	15	14	13	12	11	10	9	8
	TROC15	TROC14	TROC13	TROC12	TROC11	TROC10	TROC9	TROC8
Initial value:	0	0	0	0	0	0	0	0
R/W:	R/W	R/W	R/W	R/W	R/W	R/W	R/W	R/W
Bit:	7	6	5	4	3	2	1	0
	TROC7	TROC6	TROC5	TROC4	TROC3	TROC2	TROC1	TROC0
Initial value:	0	0	0	0	0	0	0	0
R/W:	R/W	R/W	R/W	R/W	R/W	R/W	R/W	R/W

TROCR is a 16-bit counter that indicates the number of frames that were unable to be transmitted in 16 retransmission attempts. When 16 transmission attempts have failed, TROCR is incremented by 1. When the value in this register reaches H'FFFF (65,535), the count is halted. The counter value is cleared to 0 by a write to this register (the write value is immaterial).

Bits 31 to 16—Reserved: These bits are always read as 0. The write value should always be 0.

Bits 15 to 0—Transmit Retry Over Count 15 to 0 (TROC15 to TROC0): These bits indicate the number of frames that were unable to be transmitted in 16 retransmission attempts.

9.2.10 Single Collision Detect Counter Register (SCDCR)

This register is a 32-bit counter that indicates the number of collisions on all lines from a start of transmission. When the value in this register reaches H'FFFFFFFF, count-up is halted. The counter's value is cleared to 0 by writing to this register. The value written is “don't care”.

Bit:	31	30	29	28	27	26	25	24
	COSDC31	COSDC30	COSDC29	COSDC28	COSDC27	COSDC26	COSDC25	COSDC24
Initial value:	0	0	0	0	0	0	0	0
R/W:	R/W	R/W	R/W	R/W	R/W	R/W	R/W	R/W
Bit:	23	22	21	20	19	18	17	16
	COSDC23	COSDC22	COSDC21	COSDC20	COSDC19	COSDC18	COSDC17	COSDC16
Initial value:	0	0	0	0	0	0	0	0
R/W:	R/W	R/W	R/W	R/W	R/W	R/W	R/W	R/W
Bit:	15	14	13	12	11	10	9	8
	COSDC15	COSDC14	COSDC13	COSDC12	COSDC11	COSDC10	COSDC9	COSDC8
Initial value:	0	0	0	0	0	0	0	0
R/W:	R/W	R/W	R/W	R/W	R/W	R/W	R/W	R/W
Bit:	7	6	5	4	3	2	1	0
	COSDC7	COSDC6	COSDC5	COSDC4	COSDC3	COSDC2	COSDC1	COSDC0
Initial value:	0	0	0	0	0	0	0	0
R/W:	R/W	R/W	R/W	R/W	R/W	R/W	R/W	R/W

Bits 31 to 0— Collision Detect Count 31 to 0 (COSDC31 to COSDC0): These bits indicate the number of collisions from a start of transmission.

9.2.11 Delay Collision Detect Counter Register (CDCR)

Bit:	31	30	29	...	19	18	17	16
	—	—	—	...	—	—	—	—
Initial value:	0	0	0	...	0	0	0	0
R/W:	R	R	R	...	R	R	R	R
Bit:	15	14	13	12	11	10	9	8
	COLDC15	COLDC14	COLDC13	COLDC12	COLDC11	COLDC10	COLDC9	COLDC8
Initial value:	0	0	0	0	0	0	0	0
R/W:	R/W	R/W	R/W	R/W	R/W	R/W	R/W	R/W
Bit:	7	6	5	4	3	2	1	0
	COLDC7	COLDC6	COLDC5	COLDC4	COLDC3	COLDC2	COLDC1	COLDC0
Initial value:	0	0	0	0	0	0	0	0
R/W:	R/W	R/W	R/W	R/W	R/W	R/W	R/W	R/W

CDCR is a 16-bit counter that indicates the number of collisions that occurred on the line, counting from a point 512 bits after the start of data transmission. When the value in this register reaches H'FFFF (65,535), the count is halted. The counter value is cleared to 0 by a write to this register (the write value is immaterial).

Bits 31 to 16—Reserved: These bits are always read as 0. The write value should always be 0.

Bits 15 to 0—Collision Detect Count 15 to 0 (COLDC15 to COLDC0): These bits indicate the count of collisions from a point 512 bits after the start of data transmission.

9.2.12 Lost Carrier Counter Register (LCCR)

Bit:	31	30	29	...	19	18	17	16
	—	—	—	...	—	—	—	—
Initial value:	0	0	0	...	0	0	0	0
R/W:	R	R	R	...	R	R	R	R
Bit:	15	14	13	12	11	10	9	8
	LCC15	LCC14	LCC13	LCC12	LCC11	LCC10	LCC9	LCC8
Initial value:	0	0	0	0	0	0	0	0
R/W:	R/W	R/W	R/W	R/W	R/W	R/W	R/W	R/W
Bit:	7	6	5	4	3	2	1	0
	LCC7	LCC6	LCC5	LCC4	LCC3	LCC2	LCC1	LCC0
Initial value:	0	0	0	0	0	0	0	0
R/W:	R/W	R/W	R/W	R/W	R/W	R/W	R/W	R/W

LCCR is a 16-bit counter that indicates the number of times the carrier was lost during data transmission. When the value in this register reaches H'FFFF (65,535), the count is halted. The counter value is cleared to 0 by a write to this register (the write value is immaterial).

Bits 31 to 16—Reserved: These bits are always read as 0. The write value should always be 0.

Bits 15 to 0—Lost Carrier Count 15 to 0 (LCC15 to LCC0): These bits indicate the number of times the carrier was lost during data transmission.

9.2.13 Carrier Not Detect Counter Register (CNDCR)

Bit:	31	30	29	...	19	18	17	16
	—	—	—	...	—	—	—	—
Initial value:	0	0	0	...	0	0	0	0
R/W:	R	R	R	...	R	R	R	R
Bit:	15	14	13	12	11	10	9	8
	CNDC15	CNDC14	CNDC13	CNDC12	CNDC11	CNDC10	CNDC9	CNDC8
Initial value:	0	0	0	0	0	0	0	0
R/W:	R/W	R/W	R/W	R/W	R/W	R/W	R/W	R/W
Bit:	7	6	5	4	3	2	1	0
	CNDC7	CNDC6	CNDC5	CNDC4	CNDC3	CNDC2	CNDC1	CNDC0
Initial value:	0	0	0	0	0	0	0	0
R/W:	R/W	R/W	R/W	R/W	R/W	R/W	R/W	R/W

CNDCR is a 16-bit counter that indicates the number of times the carrier could not be detected while the preamble was being sent. When the value in this register reaches H'FFFF (65,535), the count is halted. The counter value is cleared to 0 by a write to this register (the write value is immaterial).

Bits 31 to 16—Reserved: These bits are always read as 0. The write value should always be 0.

Bits 15 to 0—Carrier Not Detect Count 15 to 0 (CNDC15 to CNDC0): These bits indicate the number of times the carrier was not detected.

9.2.14 Illegal Frame Length Counter Register (IFLCR)

Bit:	31	30	29	...	19	18	17	16
	—	—	—	...	—	—	—	—
Initial value:	0	0	0	...	0	0	0	0
R/W:	R	R	R	...	R	R	R	R
Bit:	15	14	13	12	11	10	9	8
	IFLC15	IFLC14	IFLC13	IFLC12	IFLC11	IFLC10	IFLC9	IFLC8
Initial value:	0	0	0	0	0	0	0	0
R/W:	R/W	R/W	R/W	R/W	R/W	R/W	R/W	R/W
Bit:	7	6	5	4	3	2	1	0
	IFLC7	IFLC6	IFLC5	IFLC4	IFLC3	IFLC2	IFLC1	IFLC0
Initial value:	0	0	0	0	0	0	0	0
R/W:	R/W	R/W	R/W	R/W	R/W	R/W	R/W	R/W

IFLCR is a 16-bit counter that indicates the number of times transmission of a packet with a frame length of less than four bytes was attempted during data transmission. When the value in this register reaches H'FFFF (65,535), the count is halted. The counter value is cleared to 0 by a write to this register (the write value is immaterial).

Bits 31 to 16—Reserved: These bits are always read as 0. The write value should always be 0.

Bits 15 to 0—Illegal Frame Length Count 15 to 0 (IFLC15 to IFLC0): These bits indicate the count of illegal frame length transmission attempts.

9.2.15 CRC Error Frame Counter Register (CEFCR)

Bit:	31	30	29	...	19	18	17	16
	—	—	—	...	—	—	—	—
Initial value:	0	0	0	...	0	0	0	0
R/W:	R	R	R	...	R	R	R	R
Bit:	15	14	13	12	11	10	9	8
	CEFC15	CEFC14	CEFC13	CEFC12	CEFC11	CEFC10	CEFC9	CEFC8
Initial value:	0	0	0	0	0	0	0	0
R/W:	R/W	R/W	R/W	R/W	R/W	R/W	R/W	R/W
Bit:	7	6	5	4	3	2	1	0
	CEFC7	CEFC6	CEFC5	CEFC4	CEFC3	CEFC2	CEFC1	CEFC0
Initial value:	0	0	0	0	0	0	0	0
R/W:	R/W	R/W	R/W	R/W	R/W	R/W	R/W	R/W

CEFCR is a 16-bit counter that indicates the number of times a frame with a CRC error was received. When the value in this register reaches H'FFFF (65,535), the count is halted. The counter value is cleared to 0 by a write to this register (the write value is immaterial).

Bits 31 to 16—Reserved: These bits are always read as 0. The write value should always be 0.

Bits 15 to 0—CRC Error Frame Count 15 to 0 (CEFC15 to CEFC0): These bits indicate the count of CRC error frames received.

Note: When the Permit Receive CRC Error Frame bit (PRCEF) is set to 1 in the EtherC Mode Register (ECMR), CEFCR is not incremented by reception of a frame with a CRC error.

9.2.16 Frame Receive Error Counter Register (FRECR)

Bit:	31	30	29	...	19	18	17	16
	—	—	—	...	—	—	—	—
Initial value:	0	0	0	...	0	0	0	0
R/W:	R	R	R	...	R	R	R	R
Bit:	15	14	13	12	11	10	9	8
	FREC15	FREC14	FREC13	FREC12	FREC11	FREC10	FREC9	FREC8
Initial value:	0	0	0	0	0	0	0	0
R/W:	R/W	R/W	R/W	R/W	R/W	R/W	R/W	R/W
Bit:	7	6	5	4	3	2	1	0
	FREC7	FREC6	FREC5	FREC4	FREC3	FREC2	FREC1	FREC0
Initial value:	0	0	0	0	0	0	0	0
R/W:	R/W	R/W	R/W	R/W	R/W	R/W	R/W	R/W

FRECR is a 16-bit counter that indicates the number of frames input from the PHY-LSI for which a receive error was indicated by the RX-ER pin. FRECR is incremented each time this pin becomes active. When the value in this register reaches H'FFFF (65,535), the count is halted. The counter value is cleared to 0 by a write to this register (the write value is immaterial).

Bits 31 to 16—Reserved: These bits are always read as 0. The write value should always be 0.

Bits 15 to 0—Frame Receive Error Count 15 to 0 (FREC15 to FREC0): These bits indicate the count of errors during frame reception.

9.2.17 Too-Short Frame Receive Counter Register (TSFRCCR)

Bit:	31	30	29	...	19	18	17	16
	—	—	—	...	—	—	—	—
Initial value:	0	0	0	...	0	0	0	0
R/W:	R	R	R	...	R	R	R	R
Bit:	15	14	13	12	11	10	9	8
	TSFC15	TSFC14	TSFC13	TSFC12	TSFC11	TSFC10	TSFC9	TSFC8
Initial value:	0	0	0	0	0	0	0	0
R/W:	R/W	R/W	R/W	R/W	R/W	R/W	R/W	R/W
Bit:	7	6	5	4	3	2	1	0
	TSFC7	TSFC6	TSFC5	TSFC4	TSFC3	TSFC2	TSFC1	TSFC0
Initial value:	0	0	0	0	0	0	0	0
R/W:	R/W	R/W	R/W	R/W	R/W	R/W	R/W	R/W

TSFRCCR is a 16-bit counter that indicates the number of frames of fewer than 64 bytes that have been received. When the value in this register reaches H'FFFF (65,535), the count is halted. The counter value is cleared to 0 by a write to this register (the write value is immaterial).

Bits 31 to 16—Reserved: These bits are always read as 0. The write value should always be 0.

Bits 15 to 0—Too-Short Frame Receive Count 15 to 0 (TSFC15 to TSFC0): These bits indicate the count of frames received with a length of less than 64 bytes.

9.2.18 Too-Long Frame Receive Counter Register (TLFRCR)

Bit:	31	30	29	...	19	18	17	16
	—	—	—	...	—	—	—	—
Initial value:	0	0	0	...	0	0	0	0
R/W:	R	R	R	...	R	R	R	R
Bit:	15	14	13	12	11	10	9	8
	TLFC15	TLFC14	TLFC13	TLFC12	TLFC11	TLFC10	TLFC9	TLFC8
Initial value:	0	0	0	0	0	0	0	0
R/W:	R/W	R/W	R/W	R/W	R/W	R/W	R/W	R/W
Bit:	7	6	5	4	3	2	1	0
	TLFC7	TLFC6	TLFC5	TLFC4	TLFC3	TLFC2	TLFC1	TLFC0
Initial value:	0	0	0	0	0	0	0	0
R/W:	R/W	R/W	R/W	R/W	R/W	R/W	R/W	R/W

TLFRCR is a 16-bit counter that indicates the number of frames received with a length exceeding the value specified by the receive frame length register (RFLR). When the value in this register reaches H'FFFF (65,535), the count is halted. The counter value is cleared to 0 by a write to this register (the write value is immaterial).

Bits 31 to 16—Reserved: These bits are always read as 0. The write value should always be 0.

Bits 15 to 0—Too-Long Frame Receive Count 15 to 0 (TLFC15 to TLFC0): These bits indicate the count of frames received with a length exceeding the value in RFLR.

Notes: If the value specified by RFLR is 1518 bytes, TLFRCR is incremented by reception of a frame with a length of 1519 bytes or more.

TLFRCR is not incremented when a frame containing residual bits is received. In this case, the reception of the frame is indicated in the residual-bit frame counter register (RFCR).

9.2.19 Residual-Bit Frame Counter Register (RFCR)

Bit:	31	30	29	...	19	18	17	16
	—	—	—	...	—	—	—	—
Initial value:	0	0	0	...	0	0	0	0
R/W:	R	R	R	...	R	R	R	R
Bit:	15	14	13	12	11	10	9	8
	RFC15	RFC14	RFC13	RFC12	RFC11	RFC10	RFC9	RFC8
Initial value:	0	0	0	0	0	0	0	0
R/W:	R/W	R/W	R/W	R/W	R/W	R/W	R/W	R/W
Bit:	7	6	5	4	3	2	1	0
	RFC7	RFC6	RFC5	RFC4	RFC3	RFC2	RFC1	RFC0
Initial value:	0	0	0	0	0	0	0	0
R/W:	R/W	R/W	R/W	R/W	R/W	R/W	R/W	R/W

RFCR is a 16-bit counter that indicates the number of frames received containing residual bits (less than an 8-bit unit). When the value in this register reaches H'FFFF (65,535), the count is halted. The counter value is cleared to 0 by a write to this register (the write value is immaterial).

Bits 31 to 16—Reserved: These bits are always read as 0. The write value should always be 0.

Bits 15 to 0—Residual-Bit Frame Count 15 to 0 (RFC15 to RFC0): These bits indicate the count of frames received containing residual bits.

9.2.20 Multicast Address Frame Counter Register (MAFCR)

Bit:	31	30	29	...	19	18	17	16
	—	—	—	...	—	—	—	—
Initial value:	0	0	0	...	0	0	0	0
R/W:	R	R	R	...	R	R	R	R
Bit:	15	14	13	12	11	10	9	8
	MAFC15	MAFC14	MAFC13	MAFC12	MAFC11	MAFC10	MAFC9	MAFC8
Initial value:	0	0	0	0	0	0	0	0
R/W:	R/W	R/W	R/W	R/W	R/W	R/W	R/W	R/W
Bit:	7	6	5	4	3	2	1	0
	MAFC7	MAFC6	MAFC5	MAFC4	MAFC3	MAFC2	MAFC1	MAFC0
Initial value:	0	0	0	0	0	0	0	0
R/W:	R/W	R/W	R/W	R/W	R/W	R/W	R/W	R/W

MAFCR is a 16-bit counter that indicates the number of frames received with a multicast address specified. When the value in this register reaches H'FFFF (65,535), the count is halted. The counter value is cleared to 0 by a write to this register (the write value is immaterial).

Bits 31 to 16—Reserved: These bits are always read as 0. The write value should always be 0.

Bits 15 to 0—Multicast Address Frame Count 15 to 0 (MAFC15 to MAFC0): These bits indicate the count of multicast frames received.

9.3 Operation

When a transmit command is issued from the transmit E-DMAC, the EtherC starts transmission in accordance with a predetermined transmission procedure. When the specified number of words have been transferred, transmission of one frame is terminated.

When an own-address frame (including a broadcast frame) is received, the EtherC transfers the frame to the receive E-DMAC while carrying out format checks. At the end of frame reception the EtherC carries out a CRC check, completing reception of one frame.

- Notes:
1. In actual EtherC operation, frame transmission and reception is performed continuously in combination with the E-DMACs. For details of continuous operation, see the description of E-DMAC operation.
 2. The receive data transferred to memory by the receive data E-DMAC does not include CRC data.

9.3.1 Transmission

The main transmit functions of the EtherC are as follows:

- Frame generation and transmission: Monitors the line status, then adds the preamble, SFD, and CRC to the data to be transmitted, and sends it to the MII
- CRC generation: Generates the CRC for the data field, and adds it to the transmit frame
- Transmission retry: when a collision is detected in the collision window (during the transmission of the 512-bit data that includes the preamble and SFD from the start of transmission), transmission is retried up to 15 times based on the back-off algorithm

The state transitions of the EtherC transmitter are shown in figure 9.2.

4. After waiting for the frame interval time, the transmitter enters the idle state, and if there is more transmit data, continues transmitting.

9.3.2 Reception

The EtherC receiver separates a received frame into preamble, SFD, data, and CRC, and the fields from DA (destination address) to the CRC data are transferred to the receive E-DMAC. The main receive functions of the EtherC are as follows:

- Receive frame header check: Checks the preamble and SFD, and discards a frame with an invalid pattern
- Receive frame data check: Checks the data length in the header, and reports an error status if the data length is less than 64 bytes or greater than the specified number of bytes
- Receive CRC check: Performs a CRC check on the frame data field, and reports an error status in the case of an abnormality
- Line status monitoring: Reports an error status if an illegal carrier is detected by means of the fault detection signal from the PHY-LSI
- Magic Packet monitoring: Detects a Magic Packet from all receive frames

The state transitions of the EtherC receiver are shown in figure 9.3.

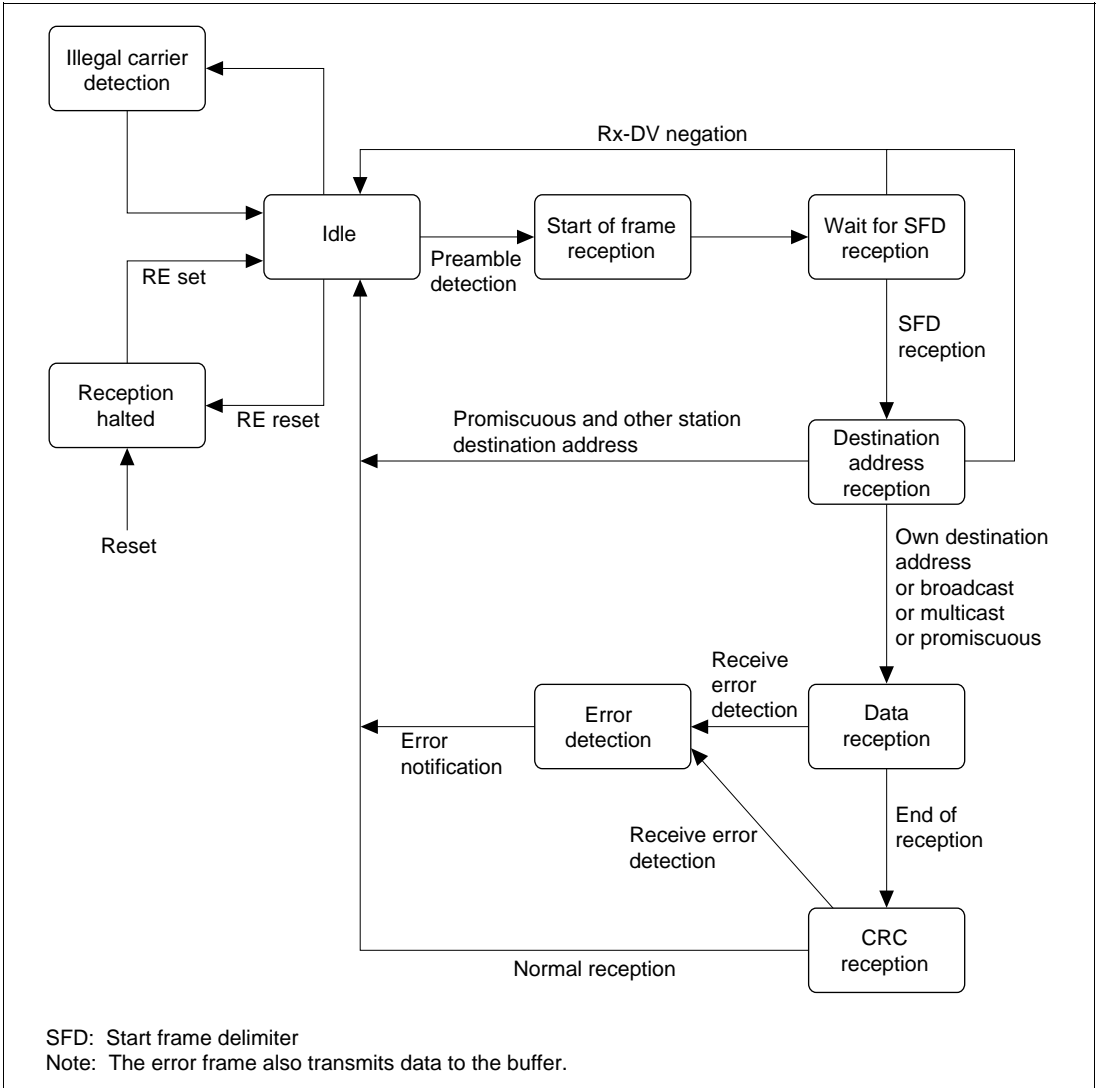

Figure 9.3 EtherC Receiver State Transitions

1. When the receive enable (RE) bit is set, the receiver enters the receive idle state.
2. When an SFD (start frame delimiter) is detected after a receive packet preamble, the receiver starts receive processing.
3. If the destination address matches the receiver's own address, or if broadcast or multicast transmission or promiscuous mode is specified, the receiver starts data reception.
4. Following data reception, the receiver carries out a CRC check. The result is indicated as a status bit in the descriptor after the frame data has been written to memory.
5. After one frame has been received, if the receive enable bit is set (RE = 1) in the EtherC mode register, the receiver prepares to receive the next frame.

9.3.3 MII Frame Timing

Figures 9.4 (a) to (f) show the timing for various kinds of MII frames. The normal timing for frame transmission is shown in figure 9.4 (a), the timing in the case of a collision during transmission in figure 9.4 (b), and the timing in the case of an error during transmission in figure 9.4 (c). The normal timing for frame reception is shown in figure 9.4 (d), and the timing in the case of errors during transmission in figures 9.4 (e) and (f).

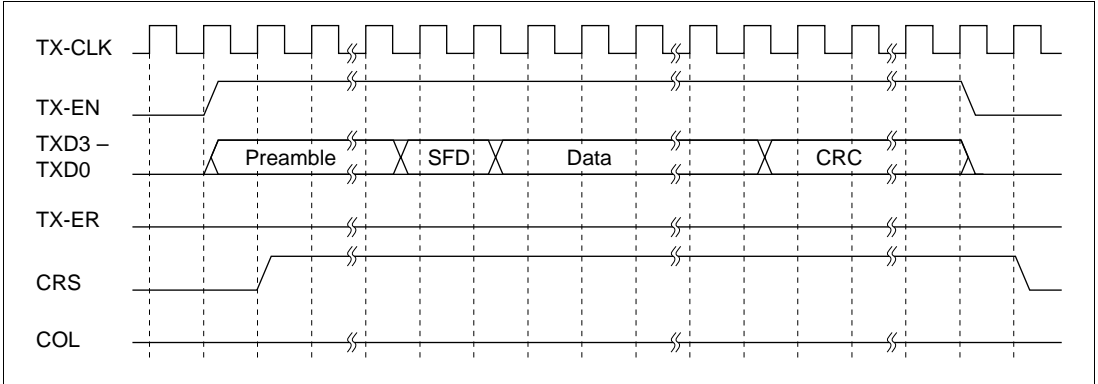

Figure 9.4 (a) MII Frame Transmit Timing (Normal Transmission)

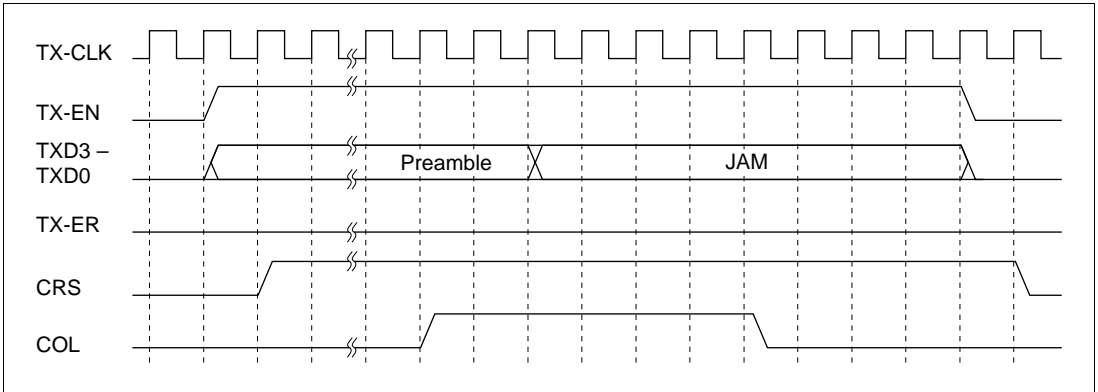

Figure 9.4 (b) MII Frame Transmit Timing (Collision)

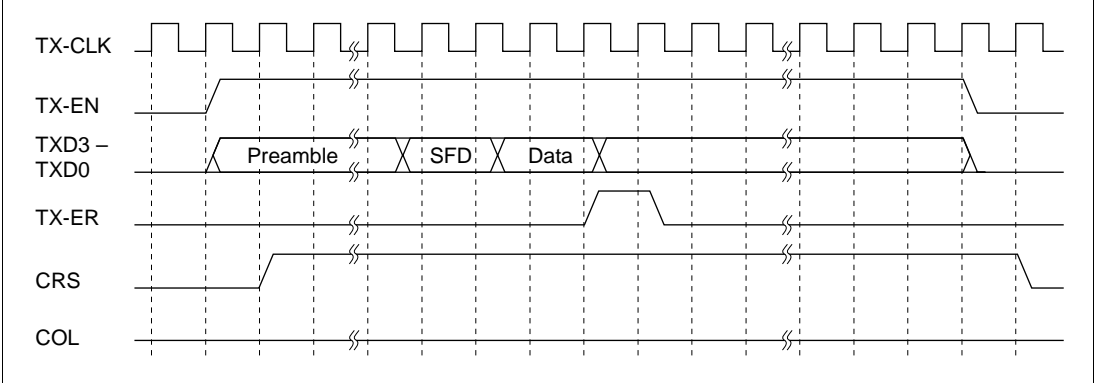

Figure 9.4 (c) MII Frame Transmit Timing (Transmit Error)

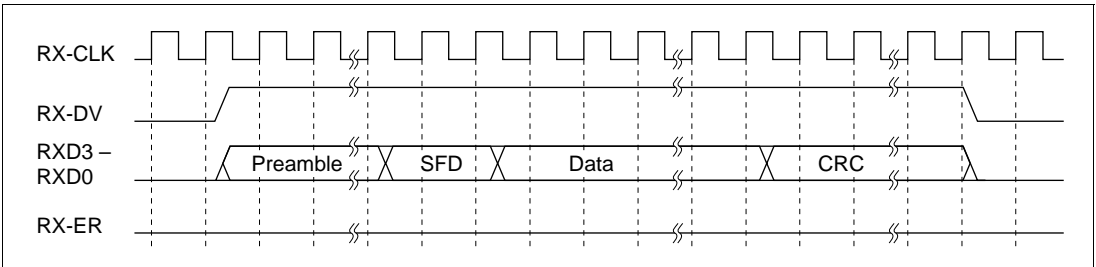

Figure 9.4 (d) MII Frame Receive Timing (Normal Reception)

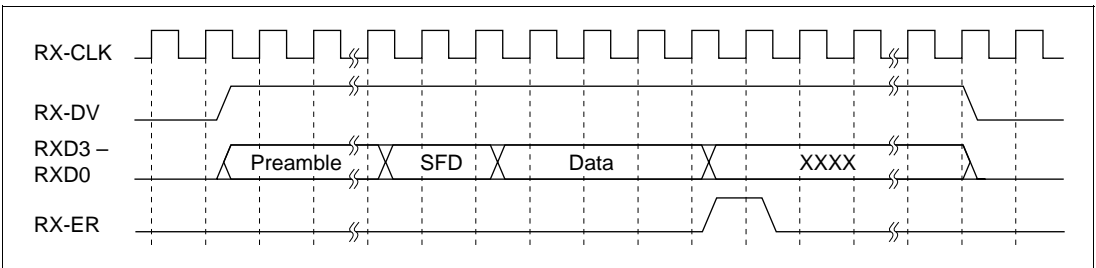

Figure 9.4 (e) MII Frame Receive Timing (Receive Error (1))

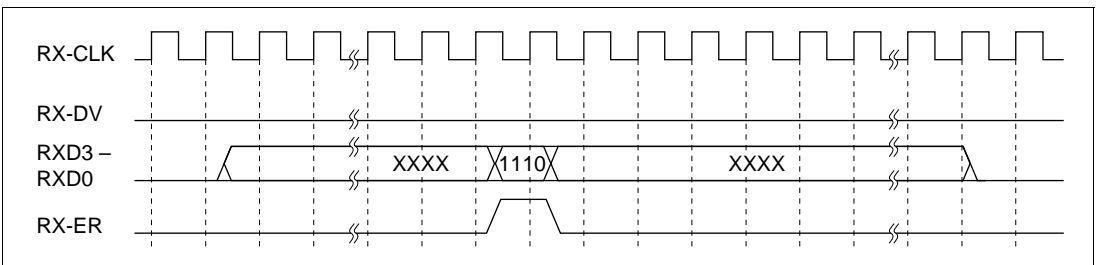

Figure 9.4 (f) MII Frame Receive Timing (Receive Error (2))

9.3.4 Accessing MII Registers

MII registers in the PHY-LSI are accessed via the SH7616's PHY interface register (PIR). Connection is made as a serial interface in accordance with the MII frame format specified in IEEE802.3u.

MII Management Frame Format: The format of an MII management frame is shown in figure 9.5. To access an MII register, a management frame is implemented by the program in accordance with the procedures shown in MII Register Access Procedure.

Access Type	MII Management Frame							
Item	PRE	ST	OP	PHYAD	REGAD	TA	DATA	IDLE
Number of bits	32	2	2	5	5	2	16	
Read	1..1	01	10	00001	RRRRR	Z0	D..D	
Write	1..1	01	01	00001	RRRRR	10	D..D	X

PRE: 32 consecutive 1s

ST: Write of 01 indicating start of frame

OP: Write of code indicating access type

PHYAD: Write of 0001 if the PHY-LSI address is 1 (sequential write starting with the MSB). This bit changes depending on the PHY-LSI address.

REGAD: Write of 0001 if the register address is 1 (sequential write starting with the MSB). This bit changes depending on the PHY-LSI register address.

TA: Time for switching data transmission source on MII interface
 (a) Write: 10 written
 (b) Read: Bus release (notation: Z0) performed

DATA: 16-bit data. Sequential write or read from MSB
 (a) Write: 16-bit data write
 (b) Read: 16-bit data read

IDLE: Wait time until next MII management format input
 (a) Write: Independent bus release (notation: X) performed
 (b) Read: Bus already released in TA; control unnecessary

Figure 9.5 MII Management Frame Format

MII Register Access Procedure: The program accesses MII registers via the PHY interface register (PIR). Access is implemented by a combination of 1-bit-unit data write, 1-bit-unit data read, bus release, and independent bus release. Examples 1 through 4 below show the register access timing. The timing will differ depending on the PHY-LSI type.

1. The MII register write procedure is shown in figure 9.6 (a).
2. The bus release procedure is shown in figure 9.6 (b).

3. The MII register read procedure is shown in figure 9.6 (c).
4. The independent bus release procedure is shown in figure 9.6 (d).

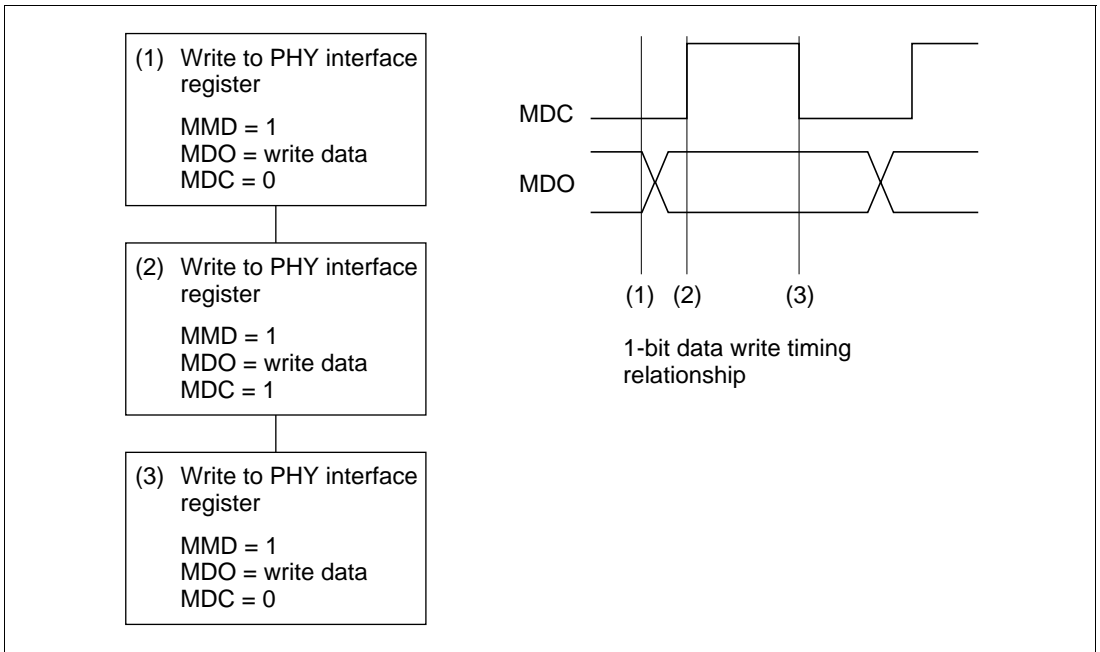

Figure 9.6 (a) 1-Bit Data Write Flowchart

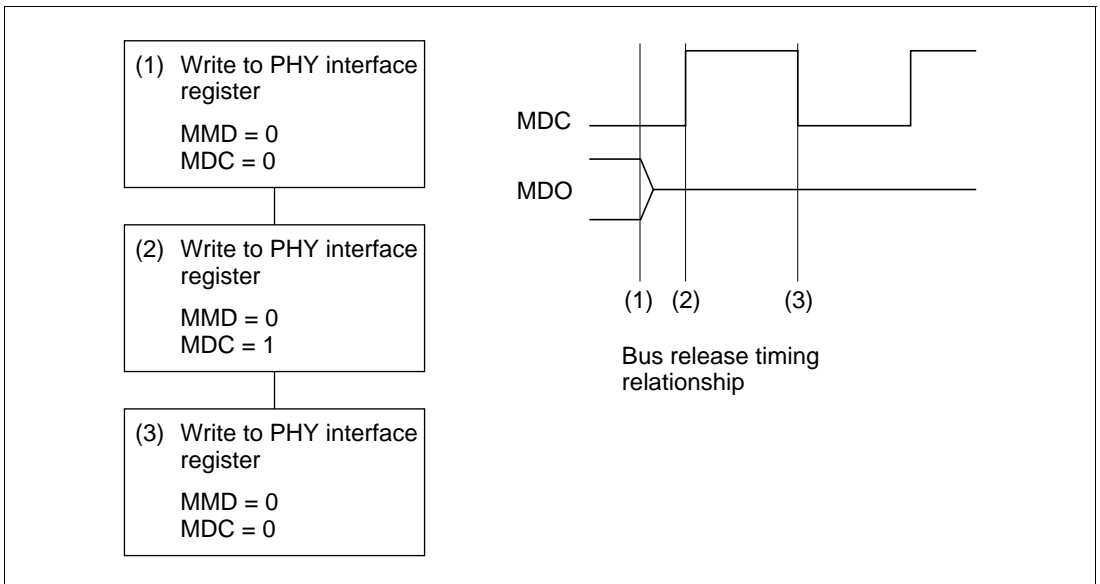

Figure 9.6 (b) Bus Release Flowchart (TA in Read in Figure 9.5)

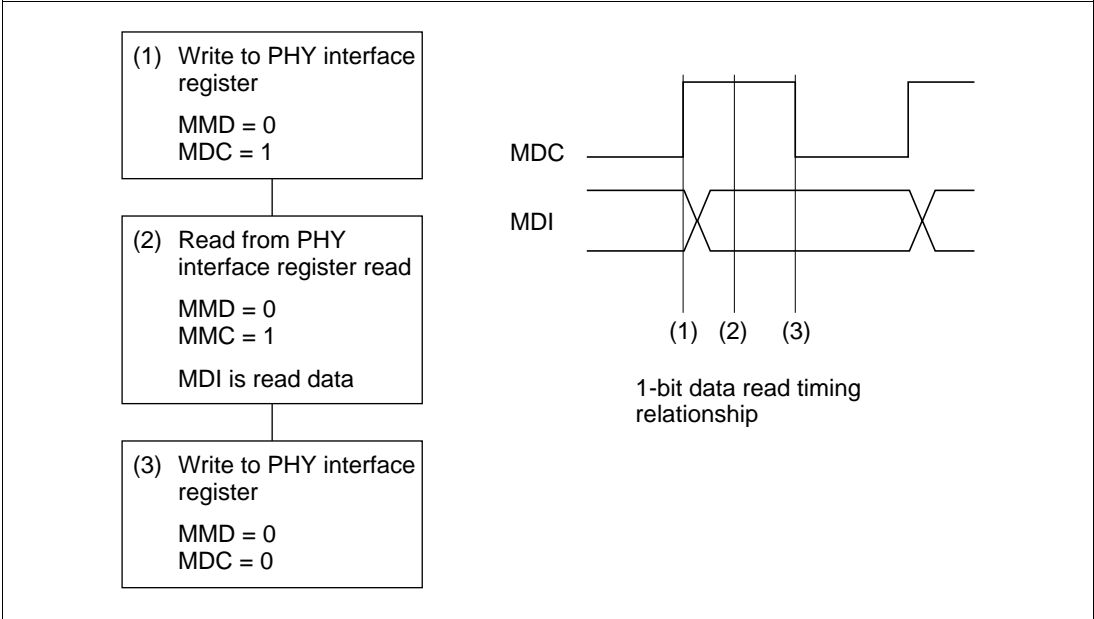

Figure 9.6 (c) 1-Bit Data Read Flowchart

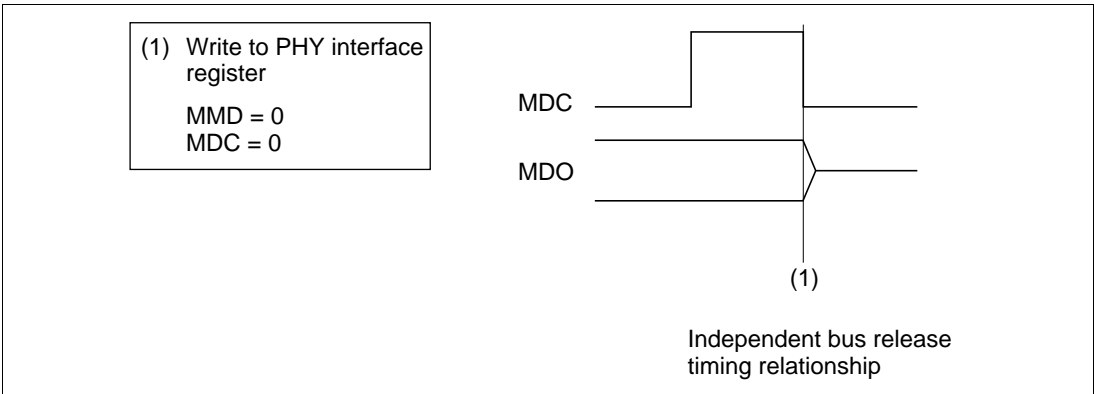

Figure 9.6 (d) Independent Bus Release Flowchart (IDLE in Write in Figure 9.5)

9.3.5 Magic Packet Detection

The EtherC has a Magic Packet detection function. This function provides a Wake-On-LAN (WOL) facility that activates various peripheral devices connected to a LAN from the host device or other source. This makes it possible to construct a system in which a peripheral device receives a Magic Packet sent from the host device or other source, and activates itself. Further information on Magic Packets can be found in the technical documentation published by AMD Corporation.

The procedure for using the WOL function with the SH7616 is as follows.

1. Disable interrupt source output by means of the various interrupt enable/mask registers.
2. Set the Magic Packet detection enable bit (MPDE) in the EtherC mode register (ECMR).
3. Set the Magic Packet detection interrupt enable bit (MPDIP) in the EtherC interrupt enable register (ECSIPR) to the enable setting.
4. If necessary, set the CPU operating mode to sleep mode or set supporting functions to module standby mode.
5. When a Magic Packet is detected, an interrupt is sent to the CPU. The WOL pin notifies peripheral LSIs that the Magic Packet has been detected.

- Notes:
1. When the Magic Packet is detected, data is stored in the receive FIFO by the broadcast packet that has received data previously and the EtherC is notified of the receiving status. To return to normal operation from the interrupt processing, initialize the EtherC and E-DMAC by using the software reset bit (SWR) in the E-DMAC mode register (EDMR).
 2. With a Magic Packet, reception is performed regardless of the destination address. As a result, this function is valid, and the WOL pin enabled, only in the case of a match with the destination address specified by the format in the Magic Packet.

9.3.6 CPU Operating Mode and Ethernet Controller Operation

The SH7616 enables a low-power-consumption system to be constructed by selecting or combining three functions: a module standby function that halts the operation of unnecessary on-chip modules, a sleep mode that halts CPU functions, and a standby function that halts all the chip's functions. Details of each operating mode are given in section 21, Power-Down State. Here, features and points for attention when these functions are used in combination with the Ethernet controller are described.

Sleep Mode: In sleep mode, the operation of the CPU and DSP is halted. The EtherC, on-chip supporting functions, and external pins continue to operate. Recovery from sleep mode can be carried out by means of an interrupt from the EtherC or a supporting module, or a reset. In order to control external pins and the WOL pin by means of Magic Packet reception, the relevant pins must be set beforehand.

Note: In order to specify recovery by means of a magic packet, supporting function interrupt sources should be masked before sleep mode is entered. See section 9.3.5, Magic Packet Detection, for the setting procedure.

Standby Mode: In standby mode, the on-chip oscillation circuit is halted. Consequently, the clock is not supplied to the EtherC, and interrupts from the EtherC and other supporting modules cannot be reported. It is therefore not possible to restore normal operation by these means, and so the WOL function cannot be used.

Notes: This mode can be selected to halt all functions including the EtherC. However, an NMI interrupt, power-on reset, or manual reset is necessary in order to restore normal operation.

When the SH7616 has been placed in standby mode, the CPU, DSP, and bus state controller are among the functions halted. When DRAM is connected, refreshing is also halted, and therefore initialization of memory, etc., is necessary after recovery, in the same way as in a reset.

Module Standby Mode: Module standby mode allows individual supporting modules to be run or halted. However, due to the nature of its function, the operation of the EtherC cannot be stopped. During normal operation, module standby mode can be used to halt unnecessary supporting functions. The CPU and DSP continue to operate in this mode.

9.3.7 CAM Match Signal Input Function

The EtherC is equipped with a CAM (Content Addressable Memory) match signal input function. A CAM circuit is externally connected to compare a destination address in a receive frame (see figure 9.7). The EtherC receives the result of comparison of a destination address corresponding to signals (RXD3 to RXD0) fetched from the MII as a signal from a CAMSEN pin and selects whether the current frame is received or discarded.

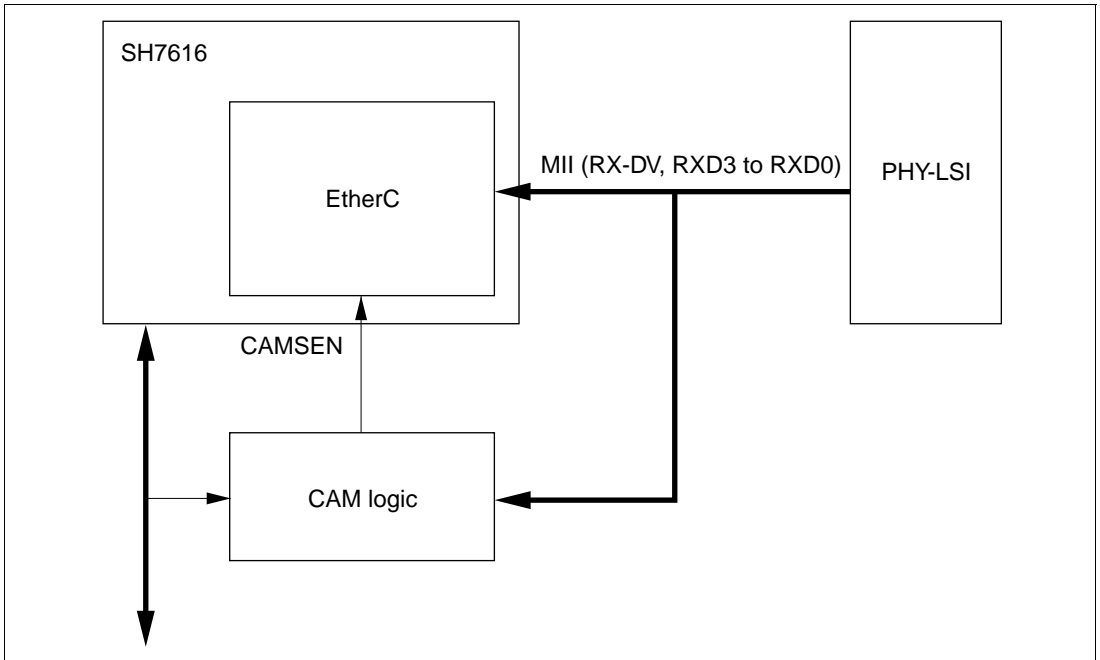

Figure 9.7 CAM Circuit Connection

Table 9.3 shows types of frames received and discarded in the two states of the CAMSEN signal. The CAM holds the MAC address besides this LSI. When the MAC address which is received from the PHY-LSI is matched with the destination address held in the CAM, the CAMSEN signal is asserted. The EtherC recognizes that the CAMSEN signal has been asserted then receives a frame for the reception.

Some of the frame's data will have already been stored in the receive FIFO when the CAMSEN signal is asserted. Therefore, when the E-DMAC is requested that the received data be discarded, the E-DMAC discards the frame. The frame must be discarded before DMA transfer starts because the E-DMAC starts transferring to main memory by DMA when at least 16 bytes of data is stored in the receive FIFO. In this case, according to the MII receive signal timing, the RX-DV is asserted and the CAMSEN signal must be asserted within 35 clock cycles of the start timing of a destination address. The fact that the CAMSEN is asserted is reflected in the RFAR bit in the

EtherC/E-DMAC status register (EESR) and this can be reflected as the write-back information of the descriptor.

Table 9.3 Processing of Receive Frames

CAMSEN Input	Frame Type	Normal Mode	Promise-CAS Mode
Asserted (address is matched)	SH7616 MAC address	Discarded	Discarded
	Broadcast address	Discarded	Discarded
	Multicast address	Discarded	Discarded
	CAM MAC addresses	Received	Discarded
Negated (address is not matched)	SH7616 MAC address	Received	Received
	Broadcast address	Received	Received
	Multicast address	Received	Received
	CAM MAC addresses	Discarded	Received

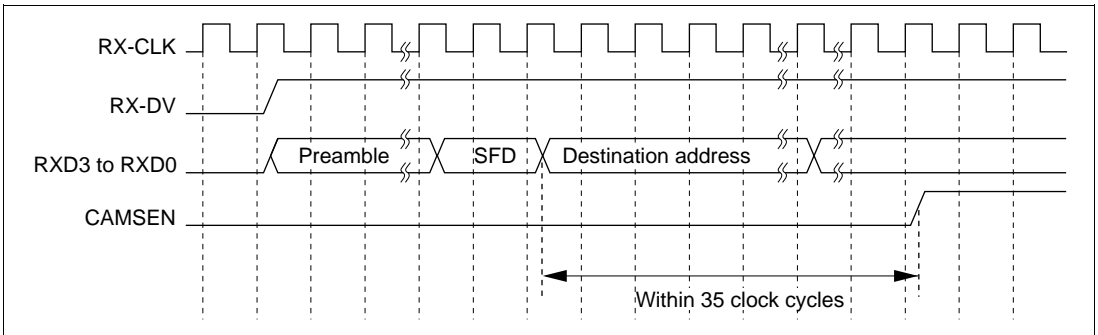

Figure 9.8 CAM Signal Timing

9.4 Connection to PHY-LSI

Figure 9.9 shows example of connection to an PHY-LSI AM79C873 (Advanced Micro Devices, Inc). Figure 9.10 shows example of connection to a DP83843 (National Semiconductor Corporation).

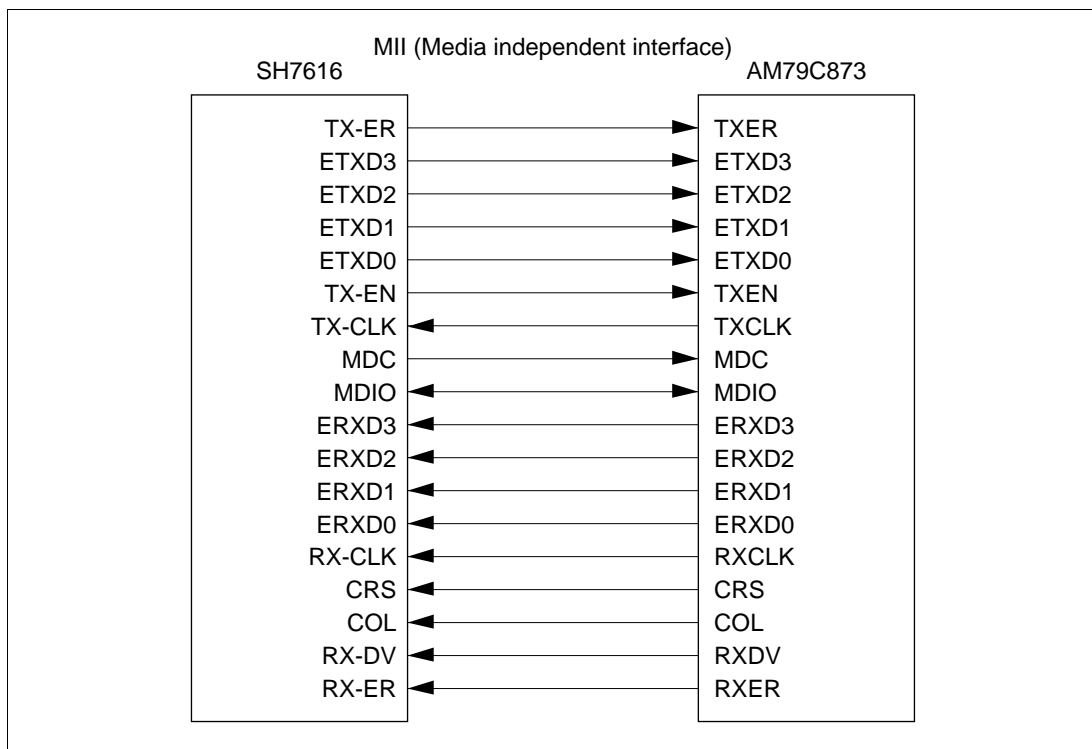

Figure 9.9 Example of Connection to AM79C873

MII (Media independent interface)

SH7616

DP83843

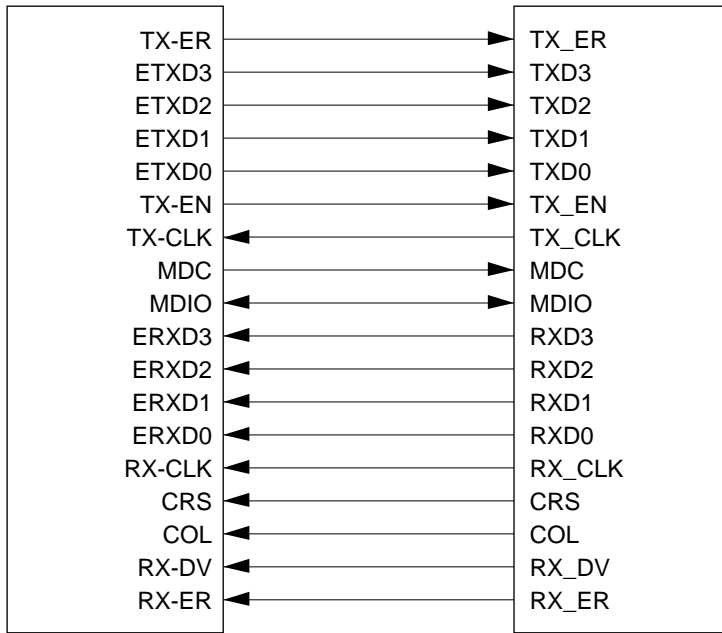

Figure 9.10 Example of Connection to DP83843

Section 10 Ethernet Controller Direct Memory Access Controller (E-DMAC)

10.1 Overview

The SH7616 has an on-chip two-channel direct memory access controller (E-DMAC) directly connected to the Ethernet controller (EtherC). A large proportion of buffer management is controlled by the E-DMAC itself using descriptors. This lightens the load on the CPU and enables efficient data transfer control to be achieved.

10.1.1 Features

The E-DMAC has the following features:

- The load on the CPU is reduced by means of a descriptor management system
- Transmit/receive frame status information is indicated in descriptors
- Achieves efficient system bus utilization through the use of block transfer (16-byte units)
- Supports single-frame/multi-buffer operation

Note: The E-DMAC cannot access peripheral modules.

10.1.2 Configuration

Figure 10.1 shows the configuration of the E-DMAC, and the descriptors and transmit/receive buffers in memory.

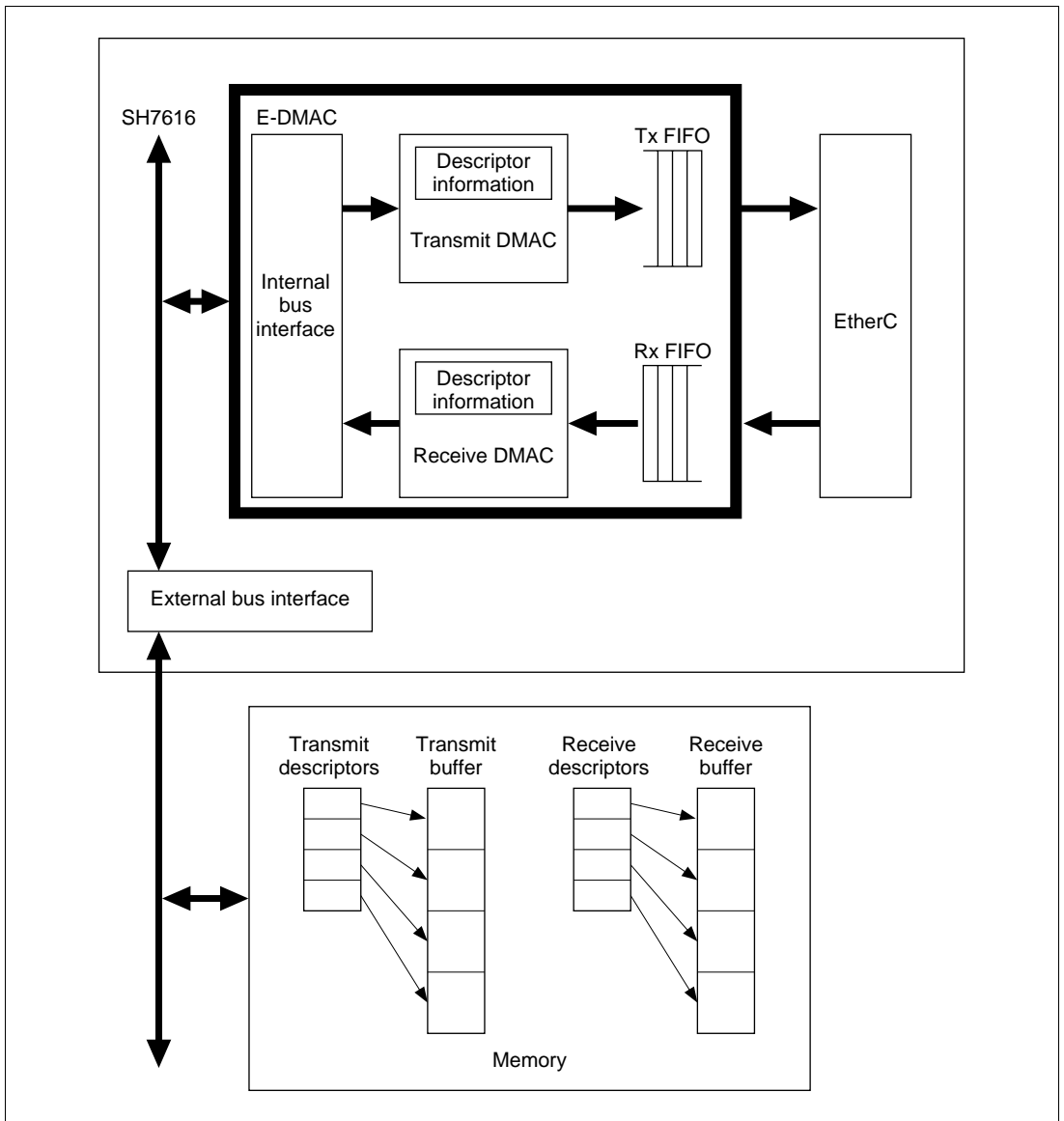

Figure 10.1 Configuration of E-DMAC, and Descriptors and Buffers

10.1.3 Descriptor Management System

The E-DMAC manages the transmit/receive buffers by means of corresponding transmit/receive descriptor lists.

Transmission: The transmit E-DMAC fetches a transmit buffer address from the top of the transmit descriptor list, and transfers the transmit data in the buffer to the transmit FIFO. If a transmit directive follows in the descriptor, the E-DMAC reads the next descriptor and transfers the data in the corresponding buffer to the transmit FIFO. In this way, continuous data transmission can be carried out.

Reception: For each start of a receive DMA transfer, the receive E-DMAC fetches a receive buffer address from the top of the receive descriptor list. When receive data is stored in the receive FIFO, the E-DMAC transfers this data to the receive buffer. When reception of one frame is finished, the E-DMAC performs a receive status write and fetches the receive buffer address from the next descriptor. By repeating this sequence, consecutive frames can be received.

10.1.4 Register Configuration

The E-DMAC has the seventeen 32-bit registers shown in table 10.1.

- Notes:
1. All registers must be accessed as 32-bit units.
 2. Reserved bits in a register should only be written with 0.
 3. The value read from a reserved bit is not guaranteed.

Table 10.1 E-DMAC Registers

Name	Abbreviation	R/W	Initial Value	Address
E-DMAC mode register	EDMR	R/W	H'00000000	H'FFFFFFD00
E-DMAC transmit request register	EDTRR	R/W	H'00000000	H'FFFFFFD04
E-DMAC receive request register	EDRRR	R/W	H'00000000	H'FFFFFFD08
Transmit descriptor list address register	TDLAR	R/W	H'00000000	H'FFFFFFD0C
Receive descriptor list address register	RDLAR	R/W	H'00000000	H'FFFFFFD10
EtherC/E-DMAC status register	EESR	R/W* ¹	H'00000000	H'FFFFFFD14
EtherC/E-DMAC status interrupt permission register	EESIPR	R/W	H'00000000	H'FFFFFFD18
Transmit/receive status copy enable register	TRSCER	R/W	H'00000000	H'FFFFFFD1C
Receive missed-frame counter register	RMFCR	R/W* ²	H'00000000	H'FFFFFFD20
Transmit FIFO threshold register	TFTR	R/W	H'00000000	H'FFFFFFD24
FIFO depth register	FDR	R/W	H'00000000	H'FFFFFFD28
Receiver control register	RCR	R/W	H'00000000	H'FFFFFFD2C
E-DMAC operation control register	EDOCR	R/W	H'00000000	H'FFFFFFD30
Receive buffer write address register	RBWAR	R	H'00000000	H'FFFFFFD40
Receive descriptor fetch address register	RDFAR	R	H'00000000	H'FFFFFFD44
Transmit buffer read address register	TBRAR	R	H'00000000	H'FFFFFFD4C
Transmit descriptor fetch address register	TDFAR	R	H'00000000	H'FFFFFFD50

Notes: *1 Individual bits are cleared by writing 1.

*2 Cleared by reading the register.

10.2 Register Descriptions

10.2.1 E-DMAC Mode Register (EDMR)

The E-DMAC mode register specifies the operating mode of the E-DMAC. The settings in this register are normally made in the initialization process following a reset.

Note: Operating mode settings must not be changed while the transmitter and receiver are enabled. To change the operating mode, first return the EtherC and E-DMAC modules to their initial state by means of the software reset bit (SWR) in this register, then make new settings.

Bit:	31	30	29	...	11	10	9	8
	—	—	—	...	—	—	—	—
Initial value:	0	0	0	...	0	0	0	0
R/W:	R	R	R	...	R	R	R	R
Bit:	7	6	5	4	3	2	1	0
	—	—	DL1	DL0	—	—	—	SWR
Initial value:	0	0	0	0	0	0	0	0
R/W:	R	R	R/W	R/W	R	R	R	R/W

Bits 31 to 6—Reserved: These bits are always read as 0. The write value should always be 0.

Bits 5 and 4—Descriptor Length 1, 0 (DL1, DL0): These bits specify the descriptor length,

Bit 5: DL1	Bit 4: DL0	Description
0	0	16 bytes (Initial value)
	1	32 bytes
1	0	64 bytes
	1	Reserved (setting prohibited)

Bits 3 to 1—Reserved: These bits are always read as 0. The write value should always be 0.

Bit 0—Software Reset (SWR): The EtherC and E-DMAC can be initialized by software. These bits should only be written with 0.

Bit 0: SWR	Description
0	EtherC and E-DMAC reset is cleared (Initial value)
1	EtherC and E-DMAC are reset

- Notes:
1. If the EtherC and E-DMAC are initialized by means of this register during data transmission, etc., abnormal data may be sent onto the line.
 2. The EtherC and E-DMAC are initialized in 16 internal clocks. Therefore, before accessing registers in the EtherC and E-DMAC, 16 internal clocks must be waited for.
 3. The E-DMAC's TDLAR, RDLAR, and RMFCRL registers are not initialized. All other EtherC and E-DMAC registers are initialized.

10.2.2 E-DMAC Transmit Request Register (EDTRR)

The E-DMAC transmit request register issues transmit directives to the E-DMAC.

Bit:	31	30	29	...	11	10	9	8
	—	—	—	...	—	—	—	—
Initial value:	0	0	0	...	0	0	0	0
R/W:	R	R	R	...	R	R	R	R
Bit:	7	6	5	4	3	2	1	0
	—	—	—	—	—	—	—	TR
Initial value:	0	0	0	0	0	0	0	0
R/W:	R	R	R	R	R	R	R	R/W

Bits 31 to 1—Reserved: These bits are always read as 0. The write value should always be 0.

Bit 0—Transmit Request (TR): When 1 is written to this bit, the E-DMAC reads a descriptor, and in the case of an active descriptor, transfers the data in the transmit buffer to the EtherC.

Bit 0: TR	Description
0	Transmission-halted state. Writing 0 does not stop transmission. Termination of transmission is controlled by the active bit in the transmit descriptor
1	Start of transmission. The relevant descriptor is read and a frame is sent with the transmit active bit set to 1

Note: When transmission of one frame is completed, the next descriptor is read. If the transmit descriptor active bit in this descriptor has the “active” setting, transmission is continued. If the transmit descriptor active bit has the “inactive” setting, the TR bit is cleared and operation of the transmit DMAC is halted.

10.2.3 E-DMAC Receive Request Register (EDRRR)

The E-DMAC receive request register issues receive directives to the E-DMAC.

Bit:	31	30	29	...	11	10	9	8
	—	—	—	...	—	—	—	—
Initial value:	0	0	0	...	0	0	0	0
R/W:	R	R	R	...	R	R	R	R
Bit:	7	6	5	4	3	2	1	0
	—	—	—	—	—	—	—	RR
Initial value:	0	0	0	0	0	0	0	0
R/W:	R	R	R	R	R	R	R	R/W

Bits 31 to 1—Reserved: These bits are always read as 0. The write value should always be 0.

Bit 0—Receive Request (RR): When 1 is written to this bit, the E-DMAC reads a descriptor, and then transfers receive data to the buffer in response to receive requests from the EtherC.

Bit 0: RR	Description
0	After frame reception is completed, the receiver is disabled
1	A receive descriptor is read, and transfer is enabled

Notes: In order to receive a frame in response to a receive request, the receive descriptor active bit in the receive descriptor must be set to “active” beforehand.

1. When the receive request bit is set, the E-DMAC reads the relevant receive descriptor.
2. If the receive descriptor active bit in the descriptor has the “active” setting, the E-DMAC prepares for a receive request from the EtherC.
3. When one receive buffer of data has been received, the E-DMAC reads the next descriptor and prepares to receive the next frame. If the receive descriptor active bit in the descriptor has the “inactive” setting, the RR bit is cleared and operation of the receive DMAC is halted.

10.2.4 Transmit Descriptor List Address Register (TDLAR)

TDLAR specifies the start address of the transmit descriptor list. Descriptors have a boundary configuration in accordance with the descriptor length indicated by the DL bit in EDMR.

Bit:	31	30	29	28	27	26	25	24
	TDLA31	TDLA30	TDLA29	TDLA28	TDLA27	TDLA26	TDLA25	TDLA24
Initial value:	0	0	0	0	0	0	0	0
R/W:	R/W	R/W	R/W	R/W	R/W	R/W	R/W	R/W
Bit:	23	22	21	20	19	18	17	16
	TDLA23	TDLA22	TDLA21	TDLA20	TDLA19	TDLA18	TDLA17	TDLA16
Initial value:	0	0	0	0	0	0	0	0
R/W:	R/W	R/W	R/W	R/W	R/W	R/W	R/W	R/W
Bit:	15	14	13	12	11	10	9	8
	TDLA15	TDLA14	TDLA13	TDLA12	TDLA11	TDLA10	TDLA9	TDLA8
Initial value:	0	0	0	0	0	0	0	0
R/W:	R/W	R/W	R/W	R/W	R/W	R/W	R/W	R/W
Bit:	7	6	5	4	3	2	1	0
	TDLA7	TDLA6	TDLA5	TDLA4	TDLA3	TDLA2	TDLA1	TDLA0
Initial value:	0	0	0	0	0	0	0	0
R/W:	R/W	R/W	R/W	R/W	R/W	R/W	R/W	R/W

Bits 31 to 0—Transmit Descriptor Start Address 31 to 0 (TDLA31 to TDLA0) : These bits should only be written with 0.

Notes: The lower bits are set as follows according to the specified descriptor length.

16-byte boundary: TDLA[3:0] = 0000

32-byte boundary: TDLA[4:0] = 00000

64-byte boundary: TDLA[5:0] = 000000

This register must not be written to during transmission. Modifications to this register should only be made while transmission is disabled.

10.2.5 Receive Descriptor List Address Register (RDLAR)

RDLAR specifies the start address of the receive descriptor list. Descriptors have a boundary configuration in accordance with the descriptor length indicated by the DL bit in EDMR.

Bit:	31	30	29	28	27	26	25	24
	RDLA31	RDLA30	RDLA29	RDLA28	RDLA27	RDLA26	RDLA25	RDLA24
Initial value:	0	0	0	0	0	0	0	0
R/W:	R/W	R/W	R/W	R/W	R/W	R/W	R/W	R/W
Bit:	23	22	21	20	19	18	17	16
	RDLA23	RDLA22	RDLA21	RDLA20	RDLA19	RDLA18	RDLA17	RDLA16
Initial value:	0	0	0	0	0	0	0	0
R/W:	R/W	R/W	R/W	R/W	R/W	R/W	R/W	R/W
Bit:	15	14	13	12	11	10	9	8
	RDLA15	RDLA14	RDLA13	RDLA12	RDLA11	RDLA10	RDLA9	RDLA8
Initial value:	0	0	0	0	0	0	0	0
R/W:	R/W	R/W	R/W	R/W	R/W	R/W	R/W	R/W
Bit:	7	6	5	4	3	2	1	0
	RDLA7	RDLA6	RDLA5	RDLA4	RDLA3	RDLA2	RDLA1	RDLA0
Initial value:	0	0	0	0	0	0	0	0
R/W:	R/W	R/W	R/W	R/W	R/W	R/W	R/W	R/W

Bits 31 to 0—Receive Descriptor Start Address 31 to 0 (RDLA31 to RDLA0)

Notes: The lower bits are set as follows according to the specified descriptor length.

16-byte boundary: RDLA[3:0] = 0000

32-byte boundary: RDLA[4:0] = 00000

64-byte boundary: RDLA[5:0] = 000000

Modifications made to this register during reception are invalid. This register should only be modified while reception is disabled.

10.2.6 EtherC/E-DMAC Status Register (EESR)

EESR shows communication status information for both the E-DMAC and the EtherC. The information in this register is reported in the form of interrupt sources. Individual bits are cleared by writing 1 to them. Each bit can also be masked by means of the corresponding bit in the EtherC/E-DMAC status interrupt permission register.

Bit:	31	30	29	28	27	26	25	24
	—	—	—	—	—	—	—	RFCOF
Initial value:	0	0	0	0	0	0	0	0
R/W:	R	R	R	R	R	R	R	R/W
Bit:	23	22	21	20	19	18	17	16
	—	ECI	TC	TDE	TFUF	FR	RDE	RFOF
Initial value:	0	0	0	0	0	0	0	0
R/W:	R	R	R/W	R/W	R/W	R/W	R/W	R/W
Bit:	15	14	13	12	11	10	9	8
	—	—	—	ITF	CND	DLC	CD	TRO
Initial value:	0	0	0	0	0	0	0	0
R/W:	R	R	R	R/W	R/W	R/W	R/W	R/W
Bit:	7	6	5	4	3	2	1	0
	RMAF	—	RFAR	RRF	RTLF	RTSF	PRE	CERF
Initial value:	0	0	0	0	0	0	0	0
R/W:	R/W	R	R/W	R/W	R/W	R/W	R/W	R/W

Bits 31 to 25—Reserved: These bits are always read as 0. The write value should always read as 0.

Bit 24—Receive Frame Counter Overflow (RFCOF): Indicates that the receive FIFO frame counter has overflowed.

Bit 24: RFCOF	Description
0	Receive frame counter has not overflowed (Initial value)
1	Receive frame counter overflow (interrupt source)

Note: The receive FIFO in the E-DMAC can hold up to eight frames. If a ninth frame is received when there are already eight frames in the receive FIFO, the receive frame counter overflows and the ninth frame is discarded. Discarded frames are counted by the missed-frame counter register. The eight frames in the receive FIFO are retained, and are transferred to memory when DMA transfer becomes possible. When the frame counter value falls below 8, another frame is received.

Bit 23—Reserved: These bits are always read as 0. The write value should always be 0.

Bit 22—EtherC States Register Interrupt (ECI): Indicates that an interrupt due to an EtherC status register (ECSR) source has been detected.

Bit 22: ECI	Description
0	EtherC status interrupt source not detected (Initial value)
1	EtherC status interrupt source detected (interrupt source)

Note: EESR is a read-only register. When this register is cleared by a source in ECSR in the EtherC, this bit is also cleared.

Bit 21—Frame Transmit Complete (TC): Indicates that all the data specified by the transmit descriptor has been transmitted to the EtherC. The transfer status is written back to the relevant descriptor. When 1-frame transmission is completed for 1-frame/1-buffer processing, or when the last data in the frame is transmitted and the transmission descriptor valid bit (TACT) in the next descriptor is not set for multiple-frame buffer processing, transmission is completed and this bit is set to 1. After frame transmission, the E-DMAC writes the transmission status back to the descriptor.

Bit 21: TC	Description
0	Transfer not complete, or no transfer directive (Initial value)
1	Transfer complete (interrupt source)

Note: As data is sent onto the line by the PHY-LSI from the EtherC via the MII, the actual transmission completion time is longer.

Bit 20—Transmit Descriptor Exhausted (TDE): Indicates that the transmission descriptor valid bit (TACT) in the descriptor is not set when the E-DMAC reads the transmission descriptor when the previous descriptor is not the last one of the frame for multiple- buffer frame processing. As a result, an incomplete frame may be transmitted.

Bit 20: TDE	Description
0	"1" transmit descriptor active bit (TACT) detected (Initial value)
1	"0" transmit descriptor active bit (TACT) detected (interrupt source)

Note: When transmission descriptor empty (TDE = 1) occurs, execute a software reset and initiate transmission. In this case, the address that is stored in the transmit descriptor list address register (TDLAR) is transmitted first.

Bit 19—Transmit FIFO Underflow (TFUF): Indicates that underflow has occurred in the transmit FIFO during frame transmission. Incomplete data is sent onto the line.

Bit 19: TFUF	Description
0	Underflow has not occurred (Initial value)
1	Underflow has occurred (interrupt source)

Note: Whether E-DMAC operation continues or halts after underflow is controlled by the E-DMAC operation control register (EDOCR).

Bit 18—Frame Received (FR): Indicates that a frame has been received and the receive descriptor has been updated. This bit is set to 1 each time a frame is received.

Note: The actual receive frame status is indicated in the receive status field in the descriptor.

Bit 18: FR	Description
0	Frame not received (Initial value)
1	Frame received (interrupt source)

Bit 17—Receive Descriptor Exhausted (RDE): This bit is set if the receive descriptor active bit (RACT) setting is "inactive" (RACT = 0) when the E-DMAC reads a receive descriptor.

Bit 17: RDE	Description
0	"1" receive descriptor active bit (RACT) detected (Initial value)
1	"0" receive descriptor active bit (RACT) detected (interrupt source)

Note: When receive descriptor empty (RDE = 1) occurs, receiving can be restarted by setting RACT = 1 in the receive descriptor and initiating receiving.

Bit 16—Receive FIFO Overflow (RFOF): Indicates that the receive FIFO has overflowed during frame reception.

Bit 16: RFOF	Description
0	Overflow has not occurred (Initial value)
1	Overflow has occurred (interrupt source)

- Notes:
1. If there are a number of receive frames in the receive FIFO, they will not be sent to memory correctly. The status of the frame that caused the overflow is written back to the receive descriptor.
 2. Whether E-DMAC operation continues or halts after overflow is controlled by the E-DMAC operation control register (EDOCR).

Bits 15 to 13—Reserved: These bits are always read as 0. The write value should always be 0.

Bit 12—Illegal Transmit Frame (ITF): Indicates that the transmit frame length specification is less than four bytes.

Bit 12: ITF	Description
0	Normal transmit frame length (Initial value)
1	Illegal transmit frame length (interrupt source)

Bit 11—Carrier Not Detect (CND): Indicates the carrier detection status.

Bit 11: CND	Description
0	A carrier is detected when transmission starts (Initial value)
1	Carrier not detected (interrupt source)

Bit 10—Detect Loss of Carrier (DLC): Indicates that loss of the carrier has been detected during frame transmission.

Bit 10: DLC	Description
0	Loss of carrier not detected (Initial value)
1	Loss of carrier detected (interrupt source)

Bit 9—Collision Detect (CD): Indicates that a collision has been detected during frame transmission.

Bit 9: CD	Description
0	Collision not detected (Initial value)
1	Collision detected (interrupt source)

Bit 8—Transmit Retry Over (TRO): Indicates that a retry-over condition has occurred during frame transmission. Total 16 transmission retries including 15 retries based on the back-off algorithm are failed after the EtherC transmission starts.

Bit 8: TRO	Description
0	Transmit retry-over condition not detected (Initial value)
1	Transmit retry-over condition detected (interrupt source)

Bit 7—Receive Multicast Address Frame (RMAF): Indicates that a multicast address frame has been received.

Bit 7: RMAF	Description
0	Multicast address frame has not been received (Initial value)
1	Multicast address frame has been received (interrupt source)

Bits 6—Reserved: This bit should only be written with 0.

Bit 5—Receive Frame Discard Request Assertion (RFAR): Indicates that a frame discard request has been asserted by the EtherC as a result of a signal from the CAM, however, it is not possible to discard the frame in the E-DMAC.

Bit 5: RFAR	Description
0	Receive frame discard request assertion has not been received (Initial value)
1	Receive frame discard request assertion has been received (interrupt source)

Bit 4—Receive Residual-Bit Frame (RRF): Indicates that a residual-bit frame has been received.

Bit 4: RRF	Description
0	Residual-bit frame has not been received (Initial value)
1	Residual-bit frame has been received (interrupt source)

Bit 3—Receive Too-Long Frame (RTLTF): Indicates that a frame of 1519 bytes or longer has been received.

Bit 3: RTLTF	Description
0	Too-long frame has not been received (Initial value)
1	Too-long frame has been received (interrupt source)

Bit 2—Receive Too-Short Frame (RTSF): Indicates that a frame of fewer than 64 bytes has been received.

Bit 2: RTSF	Description
0	Too-short frame has not been received (Initial value)
1	Too-short frame has been received (interrupt source)

Bit 1—PHY-LSI Receive Error (PRE): Indicates an error notification from the MII (PHY-LSI)

Bit 1: PRE	Description
0	PHY-LSI receive error not detected (Initial value)
1	PHY-LSI receive error detected (interrupt source)

Bit 0—CRC Error on Received Frame (CERF): Indicates that a CRC error has been detected in the received frame.

Bit 0: CERF	Description
0	CRC error not detected (Initial value)
1	CRC error detected (interrupt source)

10.2.7 EtherC/E-DMAC Status Interrupt Permission Register (EESIPR)

EESIPR enables interrupts corresponding to individual bits in the EtherC/E-DMAC status register. An interrupt is enabled by writing 1 to the corresponding bit. In the initial state, interrupts are not enabled.

Bit:	31	30	29	28	27	26	25	24
	—	—	—	—	—	—	—	RFCOFIP
Initial value:	0	0	0	0	0	0	0	0
R/W:	R	R	R	R	R	R	R	R/W
Bit:	23	22	21	20	19	18	17	16
	—	ECIIP	TCIP	TDEIP	TFUFIP	FRIP	RDEIP	RFOFIP
Initial value:	0	0	0	0	0	0	0	0
R/W:	R	R/W	R/W	R/W	R/W	R/W	R/W	R/W
Bit:	15	14	13	12	11	10	9	8
	—	—	—	ITFIP	CNDIP	DLCIP	CDIP	TROIP
Initial value:	0	0	0	0	0	0	0	0
R/W:	R	R	R	R/W	R/W	R/W	R/W	R/W
Bit:	7	6	5	4	3	2	1	0
	RMAFIP	—	RFARIP	RRFIP	RTLFIIP	RTSFIP	PREIP	CERFIP
Initial value:	0	0	0	0	0	0	0	0
R/W:	R/W	R	R/W	R/W	R/W	R/W	R/W	R/W

Bits 31 to 25—Reserved: These bits are always read as 0. The write value should always be 0.

Bit 24—Receive Frame Counter Overflow Interrupt Permission (RFCOFIP): Enables the receive frame counter overflow interrupt.

Bit 24: RFCOFIP Description

0	Receive frame counter overflow interrupt is disabled	(Initial value)
1	Receive frame counter overflow interrupt is enabled	

Bit 23—Reserved: This bit is always read as 0. The write value should always be 0.

Bit 22—EtherC Status Register Interrupt Permission (ECIP): Enables interrupts due to EtherC status register sources.

Bit 22: ECIP	Description
0	EtherC status interrupts are disabled (Initial value)
1	EtherC status interrupts are enabled

Bit 21—Frame Transmit Complete Interrupt Permission (TCIP): Enables the frame transmit complete interrupt.

Bit 21: TCIP	Description
0	Frame transmit complete interrupt is disabled (Initial value)
1	Frame transmit complete interrupt is enabled

Bit 20—Transmit Descriptor Exhausted Interrupt Permission (TDEIP): Enables the transmit descriptor exhausted interrupt.

Bit 20: TDEIP	Description
0	Transmit descriptor exhausted interrupt is disabled (Initial value)
1	Transmit descriptor exhausted interrupt is enabled

Bit 19—Transmit FIFO Underflow Interrupt Permission (TFUFIP): Enables the transmit FIFO underflow interrupt.

Bit 19: TFUFIP	Description
0	Transmit FIFO underflow interrupt is disabled (Initial value)
1	Transmit FIFO underflow interrupt is enabled

Bit 18—Frame Received Interrupt Permission (FRIP): Enables the frame received interrupt.

Bit 18: FRIP	Description
0	Frame received interrupt is disabled (Initial value)
1	Frame received interrupt is enabled

Bit 17—Receive Descriptor Exhausted Interrupt Permission (RDEIP): Enables the receive descriptor exhausted interrupt.

Bit 17: RDEIP	Description
0	Receive descriptor exhausted interrupt is disabled (Initial value)
1	Receive descriptor exhausted interrupt is enabled

Bit 16—Receive FIFO Overflow Interrupt Permission (RFOFIP): Enables the receive FIFO overflow interrupt.

Bit 16: RFOFIP	Description
0	Receive FIFO overflow interrupt is disabled (Initial value)
1	Receive FIFO overflow interrupt is enabled

Bits 15 to 13—Reserved: These bits are always read as 0. The write value should always be 0.

Bit 12—Illegal Transmit Frame Interrupt Permission (ITFIP): Enables the illegal transmit frame interrupt.

Bit 12: ITFIP	Description
0	Illegal transmit frame interrupt is disabled (Initial value)
1	Illegal transmit frame interrupt is enabled

Bit 11—Carrier Not Detect Interrupt Permission (CNDIP): Enables the carrier not detect interrupt.

Bit 11: CNDIP	Description
0	Carrier not detect interrupt is disabled (Initial value)
1	Carrier not detect interrupt is enabled

Bit 10—Detect Loss of Carrier Interrupt Permission (DLCIP): Enables the detect loss of carrier interrupt.

Bit 10: DLCIP	Description
0	Detect loss of carrier interrupt is disabled (Initial value)
1	Detect loss of carrier interrupt is enabled

Bit 9—Collision Detect Interrupt Permission (CDIP): Enables the collision detect interrupt.

Bit 9: CDIP	Description
0	Collision detect interrupt is disabled (Initial value)
1	Collision detect interrupt is enabled

Bit 8—Transmit Retry Over Interrupt Permission (TROIP): Enables the transmit retry over interrupt.

Bit 8: TROIP	Description
0	Transmit retry over interrupt is disabled (Initial value)
1	Transmit retry over interrupt is enabled

Bit 7—Receive Multicast Address Frame Interrupt Permission (RMAFIP): Enables the receive multicast address frame interrupt.

Bit 7: RMAFIP	Description
0	Receive multicast address frame interrupt is disabled (Initial value)
1	Receive multicast address frame interrupt is enabled

Bits 6—Reserved: This bit is always read as 0. The write value should always be 0.

Bit 5—Receive Frame Discard Request Assertion Interrupt Permission (RFARIP): Enables the receive frame discard request assertion interrupt.

Bit 5: RFARIP	Description
0	Receive frame discard request assertion interrupt is disabled (Initial value)
1	Receive frame discard request assertion interrupt is enabled

Bit 4—Receive Residual-Bit Frame Interrupt Permission (RRFIP): Enables the receive residual-bit frame interrupt.

Bit 4: RRFIP	Description
0	Receive residual-bit frame interrupt is disabled (Initial value)
1	Receive residual-bit frame interrupt is enabled

Bit 3—Receive Too-Long Frame Interrupt Permission (RTLFIIP): Enables the receive too-long frame interrupt.

Bit 3: RTLFIIP	Description
0	Receive too-long frame interrupt is disabled (Initial value)
1	Receive too-long frame interrupt is enabled

Bit 2—Receive Too-Short Frame Interrupt Permission (RTSFIP): Enables the receive too-short frame interrupt.

Bit 2: RTSFIP	Description
0	Receive too-short frame interrupt is disabled (Initial value)
1	Receive too-short frame interrupt is enabled

Bit 1—PHY-LSI Receive Error Interrupt Permission (PREIP): Enables the PHY-LSI receive error interrupt.

Bit 1: PREIP	Description
0	PHY-LSI receive error interrupt is disabled (Initial value)
1	PHY-LSI receive error interrupt is enabled

Bit 0—CRC Error on Received Frame Interrupt Permission (CERFIP): Enables the CRC error on received frame interrupt.

Bit 0: CERFIP	Description
0	CRC error on received frame interrupt is disabled (Initial value)
1	CRC error on received frame interrupt is enabled

10.2.8 Transmit/Receive Status Copy Enable Register (TRSCER)

TRSCER specifies whether or not transmit and receive status information reported by bits in the EtherC/E-DMAC status register is to be indicated in the corresponding descriptor. The bits in this register correspond to EtherC/E-DMAC status register EESR[15 to 0]. When a bit is cleared to 0, the transmit status (EESR[15 to 8]) is indicated in the TFE bit of the transmit descriptor, and the receive status (EESR[7 to 0]) is indicated in the RFE bit of the receive descriptor. When a bit is set to 1, the occurrence of the corresponding source is not indicated in the descriptor. After the chip is reset, all bits are cleared to 0.

Bit:	31	30	29	...	19	18	17	16
	—	—	—	...	—	—	—	—
Initial value:	0	0	0	...	0	0	0	0
R/W:	R	R	R	...	R	R	R	R
Bit:	15	14	13	12	11	10	9	8
	—	—	—	ITFCE	CNDCE	DLCCE	CDCE	TROCE
Initial value:	0	0	0	0	0	0	0	0
R/W:	R	R	R	R/W	R/W	R/W	R/W	R/W
Bit:	7	6	5	4	3	2	1	0
	RMAFCE	—	RFARCE	RRFCE	RTLFCE	RTSFCE	PRECE	CERFCE
Initial value:	0	0	0	0	0	0	0	0
R/W:	R/W	R	R/W	R/W	R/W	R/W	R/W	R/W

For the corresponding bit sources, see section 10.2.6, EtherC/E-DMAC Status Register (EESR).

10.2.9 Receive Missed-Frame Counter Register (RMFCR)

RMFCR is a 16-bit counter that indicates the number of frames missed (discarded, and not transferred to the receive buffer) during reception. When the receive FIFO overflows, the receive frames in the FIFO are discarded. The number of frames discarded at this time are counted. When the value in this register reaches H'FFFF (65,535), the count is halted. When this register is read, the counter value is cleared to 0. Writes to this register have no effect.

Bit:	31	30	29	...	19	18	17	16
	—	—	—	...	—	—	—	—
Initial value:	0	0	0	...	0	0	0	0
R/W:	R	R	R	...	R	R	R	R

Bit:	15	14	13	12	11	10	9	8
	MFC15	MFC14	MFC13	MFC12	MFC11	MFC10	MFC9	MFC8
Initial value:	0	0	0	0	0	0	0	0
R/W:	R	R	R	R	R	R	R	R

Bit:	7	6	5	4	3	2	1	0
	MFC7	MFC6	MFC5	MFC4	MFC3	MFC2	MFC1	MFC0
Initial value:	0	0	0	0	0	0	0	0
R/W:	R	R	R	R	R	R	R	R

10.2.10 Transmit FIFO Threshold Register (TFTR)

TFTR specifies the transmit FIFO threshold at which the first transmission is started. The actual threshold is 4 times the set value. The EtherC starts transmission when the amount of data in the transmit FIFO exceeds the number of bytes specified by this register, when the transmit FIFO is full, or when 1-frame write is executed.

Note: When setting this register, do so in the transmission-halt state.

Bit:	31	30	29	...	19	18	17	16
	—	—	—	...	—	—	—	—
Initial value:	0	0	0	...	0	0	0	0
R/W:	R	R	R	...	R	R	R	R
Bit:	15	14	13	12	11	10	9	8
	—	—	—	—	—	TFT10	TFT9	TFT8
Initial value:	0	0	0	0	0	0	0	0
R/W:	R	R	R	R	R	R/W	R/W	R/W
Bit:	7	6	5	4	3	2	1	0
	TFT7	TFT6	TFT5	TFT4	TFT3	TFT2	TFT1	TFT0
Initial value:	0	0	0	0	0	0	0	0
R/W:	R/W	R/W	R/W	R/W	R/W	R/W	R/W	R/W

Bits 31 to 11—Reserved: These bits should only be written with 0.

Bits 10 to 0:

TFT	Description
H'00	Store-and-forward mode (transmission starts when one frame of data is written or transmit FIFO is full) (Initial value)
H'01	4 bytes
H'02	8 bytes
:	:
H'1F	124 bytes
H'20	128 bytes
:	:
H'3F	252 bytes
H'40	256 bytes
:	:
H'7F	508 bytes
H'80	512 bytes
:	:
H'FF	1023 bytes
H'100	1024 bytes
:	:
H'1FF	2047 bytes
H'200	2048 bytes

Note: Note: When setting a transmit FIFO, the FIFO must be set to a smaller value than the specified value of the FIFO's capacity.

10.2.11 FIFO Depth Register (FDR)

FDR specifies the depth (size) of the transmit and receive FIFOs.

Bit:	31	30	29	...	19	18	17	16
	—	—	—	...	—	—	—	—
Initial value:	0	0	0	...	0	0	0	0
R/W:	R	R	R	...	R	R	R	R
Bit:	15	14	13	12	11	10	9	8
	—	—	—	—	—	TFD2	TFD1	TFD0
Initial value:	0	0	0	0	0	0	0	0
R/W:	R	R	R	R	R	R/W	R/W	R/W
Bit:	7	6	5	4	3	2	1	0
	—	—	—	—	—	RFD2	RFD1	RFD0
Initial value:	0	0	0	0	0	0	0	0
R/W:	R	R	R	R	R	R/W	R/W	R/W

Bits 31 to 11—Reserved: These bits are always read as 0. The write value should always be 0.

Bit 10 to 8—Transmit FIFO Depth (TFD): Specifies 256 bytes to 2 kbytes in 256-byte units as the depth (size) of the transmit FIFO. The setting cannot be changed after transmission/reception has started.

Bits 10 to 8: TFD2 to TFD0 Description

Bit	Description
H'0	256 bytes (Initial value)
H'1	512 bytes
:	:
H'7	2048 bytes

Bits 7 to 3—Reserved: These bits are always read as 0. The write value should always be 0.

Bit 2 to 0—Receive FIFO Depth (RFD): Specifies 256 bytes to 2 kbytes in 256-byte units as the depth (size) of the receive FIFO. The actual FIFO depth is 256 times the set value. The setting cannot be changed after transmission/reception has started.

Bits 2 to 0: RFD2 to RFD0	Description
H'0	256 bytes (Initial value)
H'1	512 bytes
:	:
H'7	2048 bytes

10.2.12 Receiver Control Register (RCR)

RCR specifies the control method for the RE bit in ECMR when a frame is received.

Note: When setting this register, do so in the receiving-halt state.

Bit:	31	30	29	...	11	10	9	8
	—	—	—	...	—	—	—	—
Initial value:	0	0	0	...	0	0	0	0
R/W:	R	R	R	...	R	R	R	R
Bit:	7	6	5	4	3	2	1	0
	—	—	—	—	—	—	—	RNC
Initial value:	0	0	0	0	0	0	0	0
R/W:	R	R	R	R	R	R	R	R/W

Bits 31 to 1—Reserved: These bits are always read as 0. The write value should always be 0.

Bit 0—Receive Enable Control (RNC)

Bit 0: RNC	Description
0	When reception of one frame is completed, the E-DMAC writes the receive status into the descriptor and clears the RR bit in EDRRR (Initial value)
1	When reception of one frame is completed, the E-DMAC writes the receive status into the descriptor, reads the next descriptor, and prepares to receive the next frame*

Note: * This setting is normally used for continuous frame reception.

10.2.13 E-DMAC Operation Control Register (EDOCR)

EDOCR specifies the control methods used in E-DMAC operation.

Bit:	31	30	29	...	11	10	9	8
	—	—	—	...	—	—	—	—
Initial value:	0	0	0	...	0	0	0	0
R/W:	R	R	R	...	R	R	R	R
Bit:	7	6	5	4	3	2	1	0
	—	—	—	—	FEC	AEC	EDH	—
Initial value:	0	0	0	0	0	0	0	0
R/W:	R	R	R	R	R/W	R/W	R/W	R

Bits 31 to 4, and 0—Reserved: These bits are always read as 0. The write value should always be 0.

Bit 3—FIFO Error Control (FEC): Specifies E-DMAC operation when transmit FIFO underflow or receive FIFO overflow occurs.

Bit 3: FEC	Description
0	E-DMAC operation continues when underflow or overflow occurs (Initial value)
1	E-DMAC operation halts when underflow or overflow occurs

Bit 2—Address Error Control (AEC): Indicates detection of an illegal memory address in an attempted E-DMAC transfer.

Bit 2: AEC	Description
0	Illegal memory address not detected (normal operation) (Initial value)
1	Illegal memory address detected. Can be cleared by writing 0

Note: This error occurs if the memory address setting in the descriptor used by the E-DMAC is illegal.

Bit 1—E-DMAC Halted (EDH): When the SH7616's NMI input pin is asserted, E-DMAC operation is halted.

Bit 1: EDH	Description
0	The E-DMAC is operating normally (Initial value)
1	The E-DMAC has been halted by NMI pin assertion. E-DMAC operation is restarted by writing 0

Bits 0—Reserved: This bit is always read as 0. The write value should always be 0.

10.2.14 Receiving-Buffer Write Address Register (RBWAR)

This is the register for storing the buffer address to be written in the receiving buffer when the E-DMAC writes data in the receiving buffer. Which addresses in the receiving buffer are processed by the E-DMAC can be recognized by monitoring addresses displayed in this register.

Bit:	31	30	29	28	27	26	25	24
	RBWA31	RBWA30	RBWA29	RBWA28	RBWA27	RBWA26	RBWA25	RBWA24
Initial value:	0	0	0	0	0	0	0	0
R/W:	R	R	R	R	R	R	R	R

Bit:	23	22	21	20	19	18	17	16
	RBWA23	RBWA22	RBWA21	RBWA20	RBWA19	RBWA18	RBWA17	RBWA16
Initial value:	0	0	0	0	0	0	0	0
R/W:	R	R	R	R	R	R	R	R

Bit:	15	14	13	12	11	10	9	8
	RBWA15	RBWA14	RBWA13	RBWA12	RBWA11	RBWA10	RBWA9	RBWA8
Initial value:	0	0	0	0	0	0	0	0
R/W:	R	R	R	R	R	R	R	R

Bit:	7	6	5	4	3	2	1	0
	RBWA7	RBWA6	RBWA5	RBWA4	RBWA3	RBWA2	RBWA1	RBWA0
Initial value:	0	0	0	0	0	0	0	0
R/W:	R	R	R	R	R	R	R	R

Bits 31 to 0—Receiving-buffer write address (RBWA): This bit can only be read. Writing is disabled.

Note: The buffer write processing result from the E-DMAC and the value read by the register may not be the same.

10.2.15 Receiving-Descriptor Fetch Address Register (RDFAR)

This is the register for storing the descriptor start address that is required when the E-DMAC fetches descriptor information from the receiving descriptor. Which receiving descriptor information is used for processing by the E-DMAC can be recognized by monitoring addresses displayed in this register.

Bit:	31	30	29	28	27	26	25	24
	RDFA31	RDFA30	RDFA29	RDFA28	RDFA27	RDFA26	RDFA25	RDFA24
Initial value:	0	0	0	0	0	0	0	0
R/W:	R	R	R	R	R	R	R	R
Bit:	23	22	21	20	19	18	17	16
	RDFA23	RDFA22	RDFA21	RDFA20	RDFA19	RDFA18	RDFA17	RDFA16
Initial value:	0	0	0	0	0	0	0	0
R/W:	R	R	R	R	R	R	R	R
Bit:	15	14	13	12	11	10	9	8
	RDFA15	RDFA14	RDFA13	RDFA12	RDFA11	RDFA10	RDFA9	RDFA8
Initial value:	0	0	0	0	0	0	0	0
R/W:	R	R	R	R	R	R	R	R
Bit:	7	6	5	4	3	2	1	0
	RDFA7	RDFA6	RDFA5	RDFA4	RDFA3	RDFA2	RDFA1	RDFA0
Initial value:	0	0	0	0	0	0	0	0
R/W:	R	R	R	R	R	R	R	R

Bits 31 to 0—Receiving-descriptor fetch address (RDFA): This bit can only be read. Writing is disabled.

Note: The descriptor fetch processing result from the E-DMAC and the value read by the register may not be the same.

10.2.16 Transmission-Buffer Read Address Register (TBRAR)

This is the register for storing the buffer address to be read in the transmission buffer when the E-DMAC reads data from the transmission buffer. Which addresses in the transmission buffer are processed by the E-DMAC can be recognized by monitoring addresses displayed in this register.

Bit:	31	30	29	28	27	26	25	24
	TBRA31	TBRA30	TBRA29	TBRA28	TBRA27	TBRA26	TBRA25	TBRA24
Initial value:	0	0	0	0	0	0	0	0
R/W:	R	R	R	R	R	R	R	R
Bit:	23	22	21	20	19	18	17	16
	TBRA23	TBRA22	TBRA21	TBRA20	TBRA19	TBRA18	TBRA17	TBRA16
Initial value:	0	0	0	0	0	0	0	0
R/W:	R	R	R	R	R	R	R	R
Bit:	15	14	13	12	11	10	9	8
	TBRA15	TBRA14	TBRA13	TBRA12	TBRA11	TBRA10	TBRA9	TBRA8
Initial value:	0	0	0	0	0	0	0	0
R/W:	R	R	R	R	R	R	R	R
Bit:	7	6	5	4	3	2	1	0
	TBRA7	TBRA6	TBRA5	TBRA4	TBRA3	TBRA2	TBRA1	TBRA0
Initial value:	0	0	0	0	0	0	0	0
R/W:	R	R	R	R	R	R	R	R

Bits 31 to 0—Transmission-buffer read address (TBRD): This bit can only be read. Writing is disabled.

Note: The buffer read processing result from the E-DMAC and the value read by the register may not be the same.

10.2.17 Transmission-Descriptor Fetch Address Register (TDFAR)

This is the register for storing the descriptor start address that is required when the E-DMAC fetches descriptor information from the transmission descriptor . Which transmission descriptor information is used for processing by the E-DMAC can be recognized by monitoring addresses displayed in this register.

Bit:	31	30	29	28	27	26	25	24
	TDFA31	TDFA30	TDFA29	TDFA28	TDFA27	TDFA26	TDFA25	TDFA24
Initial value:	0	0	0	0	0	0	0	0
R/W:	R	R	R	R	R	R	R	R
Bit:	23	22	21	20	19	18	17	16
	TDFA23	TDFA22	TDFA21	TDFA20	TDFA19	TDFA18	TDFA17	TDFA16
Initial value:	0	0	0	0	0	0	0	0
R/W:	R	R	R	R	R	R	R	R
Bit:	15	14	13	12	11	10	9	8
	TDFA15	TDFA14	TDFA13	TDFA12	TDFA11	TDFA10	TDFA9	TDFA8
Initial value:	0	0	0	0	0	0	0	0
R/W:	R	R	R	R	R	R	R	R
Bit:	7	6	5	4	3	2	1	0
	TDFA7	TDFA6	TDFA5	TDFA4	TDFA3	TDFA2	TDFA1	TDFA0
Initial value:	0	0	0	0	0	0	0	0
R/W:	R	R	R	R	R	R	R	R

Bits 31 to 0—Transmission-descriptor fetch address (TDFA): This bit can only be read. Writing is disabled.

Note: The descriptor fetch processing result from the E-DMAC and the value read by the register may not be the same.

10.3 Operation

The E-DMAC is connected to the EtherC, and performs efficient transfer of transmit/receive data between the EtherC and memory (buffers) without the intervention of the CPU. The E-DMAC itself reads control information, including buffer pointers called descriptors, relating to the buffers. The E-DMAC reads transmit data from the transmit buffer and writes receive data to the receive buffer in accordance with this control information. By setting up a number of consecutive descriptors (a descriptor list), it is possible to execute transmission and reception continuously.

10.3.1 Descriptor List and Data Buffers

Before starting transmission/reception, the communication program creates transmit and receive descriptor lists in memory. The start addresses of these lists are then set in the transmit and receive descriptor list start address registers.

Transmit Descriptor

Figure 10.2 shows the relationship between a transmit descriptor and the transmit buffer. According to the specification in this descriptor, the relationship between the transmit frame and transmit buffer can be defined as one frame/one buffer or one frame/multi-buffer.

- Notes:
1. The descriptor's start address setting must be aligned with an address boundary that corresponds with the descriptor's length as set by the E-DMAC mode register (EDMR).
 2. The transmit buffer's start address setting must be aligned with a longword boundary. However, when SDRAM is connected, the setting must be aligned with a 16-byte boundary.

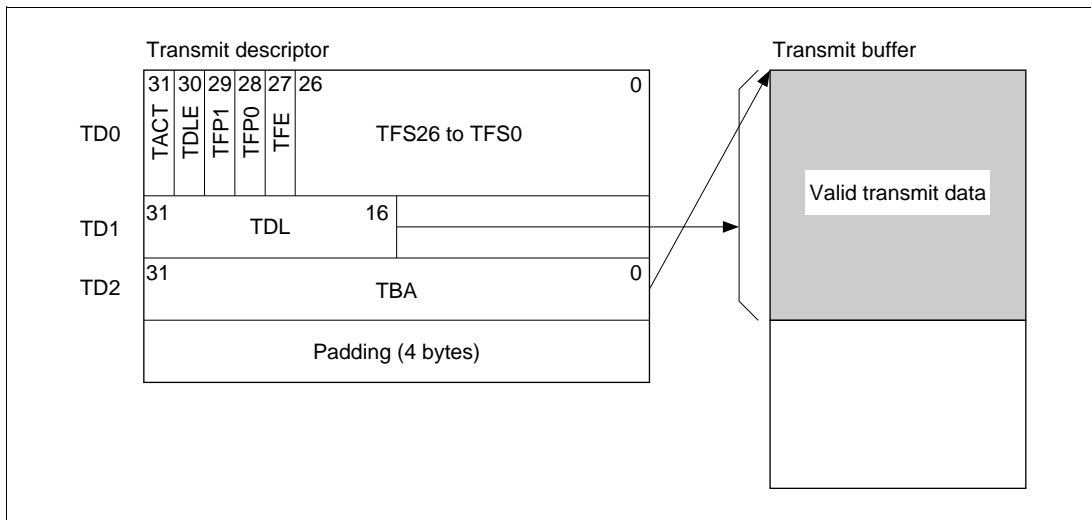

Figure 10.2 Relationship between Transmit Descriptor and Transmit Buffer

Transmit Descriptor 0 (TD0): TD0 indicates the transmit frame status. The CPU and E-DMAC use TD0 to report the frame transmission status.

Bit 31—Transmit Descriptor Active (TACT): Indicates that this descriptor is active. The CPU sets this bit after transmit data has been transferred to the transmit buffer. The E-DMAC resets this bit on completion of a frame transfer or when transmission is suspended.

Bit 31: TACT	Description
0	<p>The transmit descriptor is invalid</p> <p>Indicates that valid data has not been written to the transmit buffer by the CPU, or this bit has been reset by a write-back operation on termination of E-DMAC frame transfer processing (completion or suspension of transmission)</p> <p>If this state is recognized in an E-DMAC descriptor read, the E-DMAC terminates transmit processing and transmit operations cannot be continued (a restart is necessary)</p>
1	<p>The transmit descriptor is valid</p> <p>Indicates that valid data has been written to the transmit buffer by the CPU and frame transfer processing has not yet been executed, or that frame transfer is in progress</p> <p>When this state is recognized in an E-DMAC descriptor read, the E-DMAC continues with the transmit operation</p>

Bit 30—Transmit Descriptor List Last (TDLE): Indicates that this descriptor is the last in the transmit descriptor list. After completion of the corresponding buffer transfer, the E-DMAC references the first descriptor. This specification is used to set a ring configuration for the transmit descriptors.

Bit 30: TDLE	Description
0	This is not the last transmit descriptor list
1	This is the last transmit descriptor list

Bits 29 and 28—Transmit Frame Position 1, 0 (TFP1, TFP0): These two bits specify the relationship between the transmit buffer and transmit frame.

Bit 29: TFP1	Bit 28: TFP0	Description
0	0	Frame transmission for transmit buffer indicated by this descriptor continues (frame is not concluded)
	1	Transmit buffer indicated by this descriptor contains end of frame (frame is concluded)
1	0	Transmit buffer indicated by this descriptor is start of frame (frame is not concluded)
	1	Contents of transmit buffer indicated by this descriptor are equivalent to one frame (one frame/one buffer)

Note: In the preceding and following descriptors, a logically positive relationship must be maintained between the settings of this bit and the TDLE bit.

Bit 27—Transmit Frame Error (TFE): Indicates that one or other bit of the transmit frame status indicated by bits 26 to 0 is set. Whether or not the transmit frame status information is copied into this bit is specified by the transmit/receive status copy enable register.

Bit 27: TFE	Description
0	No error during transmission
1	An error of some kind occurred during transmission (see bits 26 to 0)

Bits 26 to 0—Transmit Frame Status 26 to 0 (TFS26 to TFS0): These bits indicate the error status during frame transmission.

- TFS26 to TFS5—Reserved
- TFS4—Illegal Transmit Frame (corresponds to ITF bit in EESR)
- TFS3—Carrier Not Detect (corresponds to CND bit in EESR)
- TFS2—Detect Loss of Carrier (corresponds to DLC bit in EESR)
- TFS1—Collision Detect (corresponds to CD bit in EESR)
- TFS0—Transmit Retry Over (corresponds to TRO bit in EESR)

Transmit Descriptor 1 (TD1): Specifies the transmit buffer length (maximum 64 kbytes).

Bits 31 to 16—Transmit Buffer Data Length (TDL): These bits specify the valid transfer byte length in the corresponding transmit buffer.

Note: When the one frame/multi-buffer system is specified (TD0 and TFP = 10 or 00), the transfer byte length specified in the descriptors at the start and midway can be set in byte units.

Bits 15 to 0—Reserved: The bits are always read as 0. The write value should always be 0.

Transmit Descriptor 2 (TD2): Specifies the 32-bit transmit buffer start address.

Note: The transmit buffer's start address setting must be aligned with a longword boundary. However, when SDRAM is connected, the setting must be aligned with a 16-byte boundary.

Bits 31 to 0—Transmit Buffer Address (TBA)

Receive Descriptor

Figure 10.3 shows the relationship between a receive descriptor and the receive buffer. In frame reception, the E-DMAC performs data rewriting up to a receive buffer 16-byte boundary, regardless of the receive frame length. Finally, the actual receive frame length is reported in the lower 16 bits of RD1 in the descriptor. Data transfer to the receive buffer is performed automatically by the E-DMAC to give a one frame/one buffer or one frame/multi-buffer configuration according to the size of one received frame.

- Notes:
1. The descriptor's start address setting must be aligned with an address boundary that corresponds with the descriptor's length as set by the E-DMAC mode register (EDMR).
 2. The receive buffer's start address setting must be aligned with a longword boundary. However, when SDRAM is connected, the setting must be aligned with a 16-byte boundary. Make the setting so that the size of the receive buffer is aligned with a 16-byte boundary.

Example: H'0500 (= 1280 bytes)

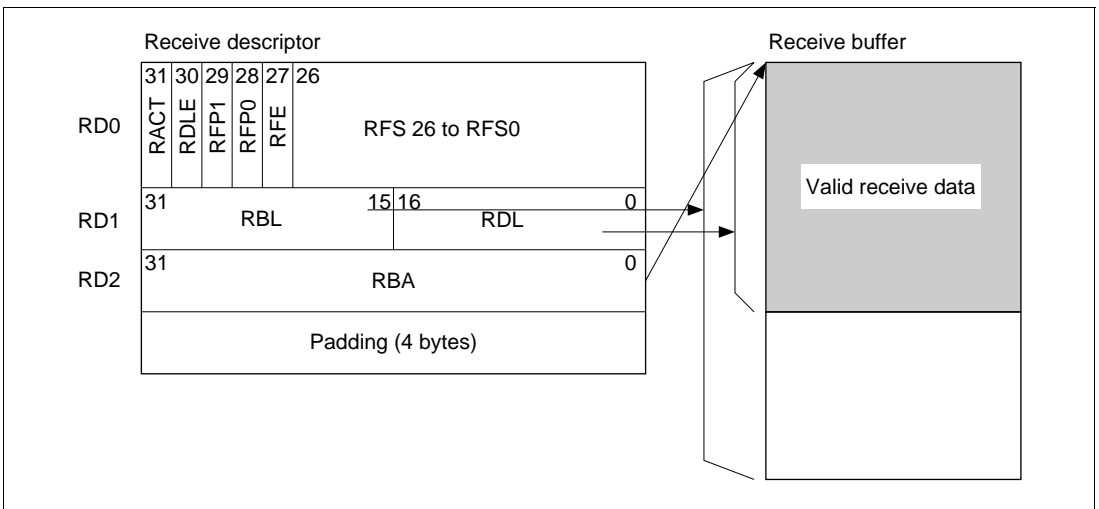

Figure 10.3 Relationship between Receive Descriptor and Receive Buffer

Receive Descriptor 0 (RD0): RD0 indicates the receive frame status. The CPU and E-DMAC use RD0 to report the frame transmission status.

Bit 31—Receive Descriptor Active (RACT): Indicates that this descriptor is active. The E-DMAC resets this bit after receive data has been transferred to the receive buffer. On completion of receive frame processing, the CPU sets this bit to prepare for reception.

Bit 31: RACT	Description
0	<p>The receive descriptor is invalid</p> <p>Indicates that the receive buffer is not ready (access disabled by E-DMAC), or this bit has been reset by a write-back operation on termination of E-DMAC frame transfer processing (completion or suspension of reception)</p> <p>If this state is recognized in an E-DMAC descriptor read, the E-DMAC terminates receive processing and receive operations cannot be continued</p> <p>Reception can be restarted by setting RACT to 1 and executing receive initiation.</p>
1	<p>The receive descriptor is valid</p> <p>Indicates that the receive buffer is ready (access enabled) and processing for frame transfer from the FIFO has not been executed, or that frame transfer is in progress</p> <p>When this state is recognized in an E-DMAC descriptor read, the E-DMAC continues with the receive operation</p>

Bit 30—Receive Descriptor List Last (RDLE): Indicates that this descriptor is the last in the receive descriptor list. After completion of the corresponding buffer transfer, the E-DMAC references the first receive descriptor. This specification is used to set a ring configuration for the receive descriptors.

Bit 30: RDLE	Description
0	This is not the last receive descriptor list
1	This is the last receive descriptor list (the next descriptor is inactive)

Bits 29 and 28—Receive Frame Position 1, 0 (RFP1, RFP0): These two bits specify the relationship between the receive buffer and receive frame.

Bit 29: RFP	Bit 28: RFP	Description
0	0	Frame reception for receive buffer indicated by this descriptor continues (frame is not concluded)
	1	Receive buffer indicated by this descriptor contains end of frame (frame is concluded)
1	0	Receive buffer indicated by this descriptor is start of frame (frame is not concluded)
	1	Contents of receive buffer indicated by this descriptor are equivalent to one frame (one frame/one buffer)

Bit 27—Receive Frame Error (RFE): Indicates that one or other bit of the receive frame status indicated by bits 26 to 0 is set. Whether or not the receive frame status information is copied into this bit is specified by the transmit/receive status copy enable register.

Bit 27: RFE	Description
0	No error during reception (Initial value)
1	An error of some kind occurred during reception (see bits 26 to 0)

Bits 26 to 0—Receive Frame Status 26 to 0 (RFS26 to RFS0): These bits indicate the error status during frame reception.

- RFS26 to RFS10—Reserved
- RFS9—Receive FIFO Overflow (corresponds to RMAF bit in EESR)
- RFS8—Reserved
- RFS7—Receive Multicast Address Frame (corresponds to RMAF bit in EESR)
- RFS6—Reserved
- RFS5—Receive Frame Discard Request Assertion (corresponds to RFAR bit in EESR)
- RFS4—Receive Residual-Bit Frame (corresponds to RRF bit in EESR)
- RFS3—Receive Too-Long Frame (corresponds to RTLf bit in EESR)
- RFS2—Receive Too-Short Frame (corresponds to RTSF bit in EESR)
- RFS1—PHY-LSI Receive Error (corresponds to PRE bit in EESR)
- RFS0—CRC Error on Received Frame (corresponds to CERF bit in EESR)

Receive Descriptor 1 (RD1): Specifies the receive buffer length (maximum 64 kbytes).

Bits 31 to 16—Receive Buffer Length (RBL): These bits specify the maximum transfer byte length in the corresponding receive buffer.

Notes: The transfer byte length must align with a 16-byte boundary (bits 19 to 16 cleared to 0). The maximum receive frame length with one frame per buffer is 1,514 bytes, excluding the CRC data. Therefore, for the receive buffer length specification, a value of 1,520 bytes (H'05F0) that takes account of a 16-byte boundary is set as the maximum receive frame length.

Bits 15 to 0—Receive Data Length (RDL): These bits specify the data length of a receive frame stored in the receive buffer.

Note: The receive data transferred to the receive buffer does not include the 4-byte CRC data at the end of the frame. The receive frame length is reported as the number of words (valid data bytes) not including this CRC data.

Receive Descriptor 2 (RD2): Specifies the 32-bit receive buffer start address.

Note: The receive buffer's start address setting must be aligned with a longword boundary. However, when SDRAM is connected, the setting must be aligned with a 16-byte boundary.

Bits 31 to 0—Receive Buffer Address (RBA)

10.3.2 Transmission

When the transmitter is enabled and the transmit request bit (TR) is set in the E-DMAC transmit request register (EDTRR), the E-DMAC reads the descriptor used last time from the transmit descriptor list (in the initial state, the descriptor indicated by the transmission descriptor start address register (TDLAR)). If the setting of the TACT bit in the read descriptor is "active," the E-DMAC reads transmit frame data sequentially from the transmit buffer start address specified by TD2, and transfers it to the EtherC. The EtherC creates a transmit frame and starts transmission to the MII. After DMA transfer of data equivalent to the buffer length specified in the descriptor, the following processing is carried out according to the TFP value.

1. TFP = 00 or 01 (frame continuation):
Descriptor write-back is performed after DMA transfer.
2. TFP = 01 or 11 (frame end):
Descriptor write-back is performed after completion of frame transmission.

The E-DMAC continues reading descriptors and transmitting frames as long as the setting of the TACT bit in the read descriptors is “active.” When a descriptor with an “inactive” TACT bit is read, the E-DMAC resets the transmit request bit (TR) in the transmit register and ends transmit processing (EDTRR).

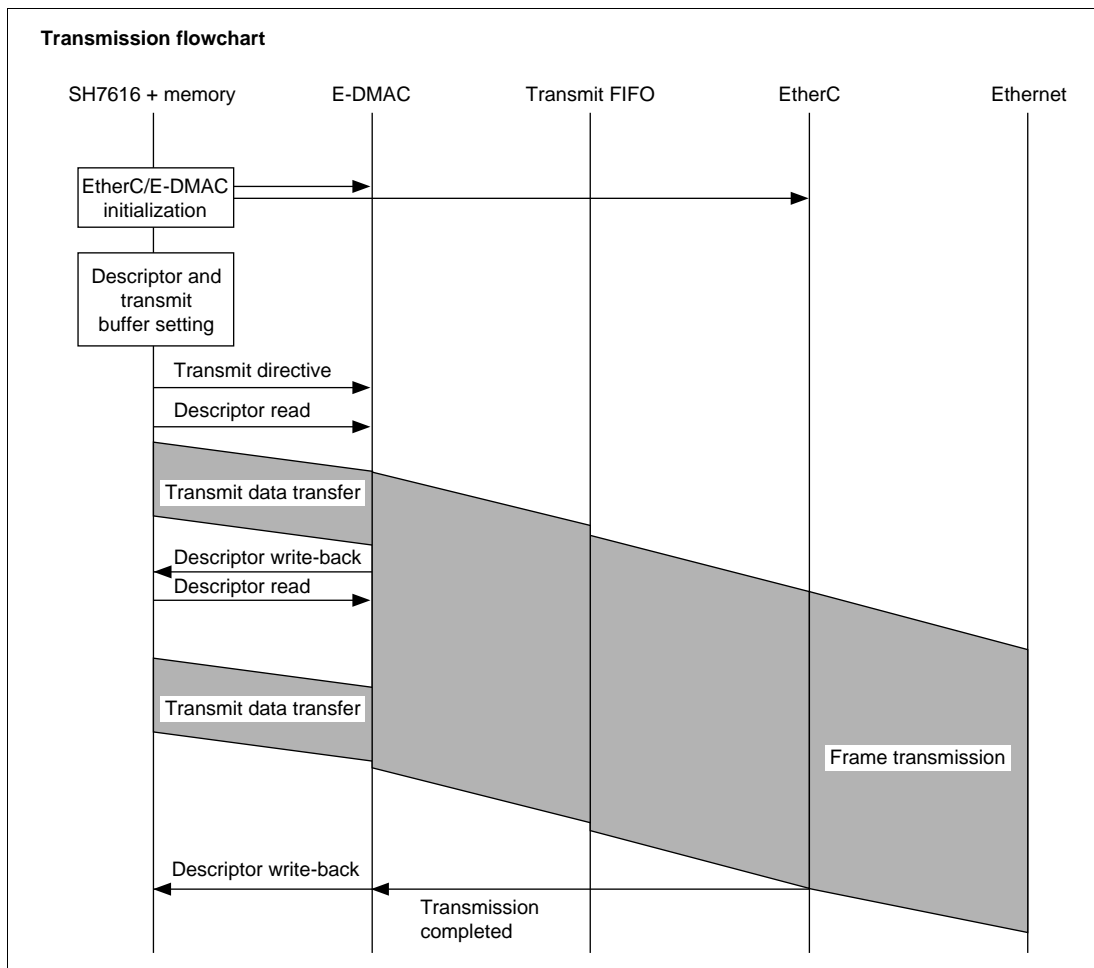

Figure 10.4 Sample Transmission Flowchart

10.3.3 Reception

When the receiver is enabled and the CPU sets the receive request bit (RR) in the E-DMAC receive request register (EDRRR), the E-DMAC reads the descriptor following the previously used one from the receive descriptor list (in the initial state, the descriptor indicated by the transmission descriptor start address register (TDLAR)), and then enters the receive-standby state. If the setting of the RACT bit is “active” and an own-address frame is received, the E-DMAC transfers the frame to the receive buffer specified by RD2. If the data length of the received frame is greater than the buffer length given by RD1, the E-DMAC performs write-back to the descriptor when the buffer is full (RFP = 10 or 00), then reads the next descriptor. The E-DMAC then continues to transfer data to the receive buffer specified by the new RD2. When frame reception is completed, or if frame reception is suspended because of an error of some kind, the E-DMAC performs write-back to the relevant descriptor (RFP = 11 or 01), and then ends the receive processing. The E-DMAC then reads the next descriptor and enters the receive-standby state again.

Note: To receive frames continuously, the receive enable control bit (RNC) must be set to 1 in the receive control register (RCR). After initialization, this bit is cleared to 0.

Reception flowchart

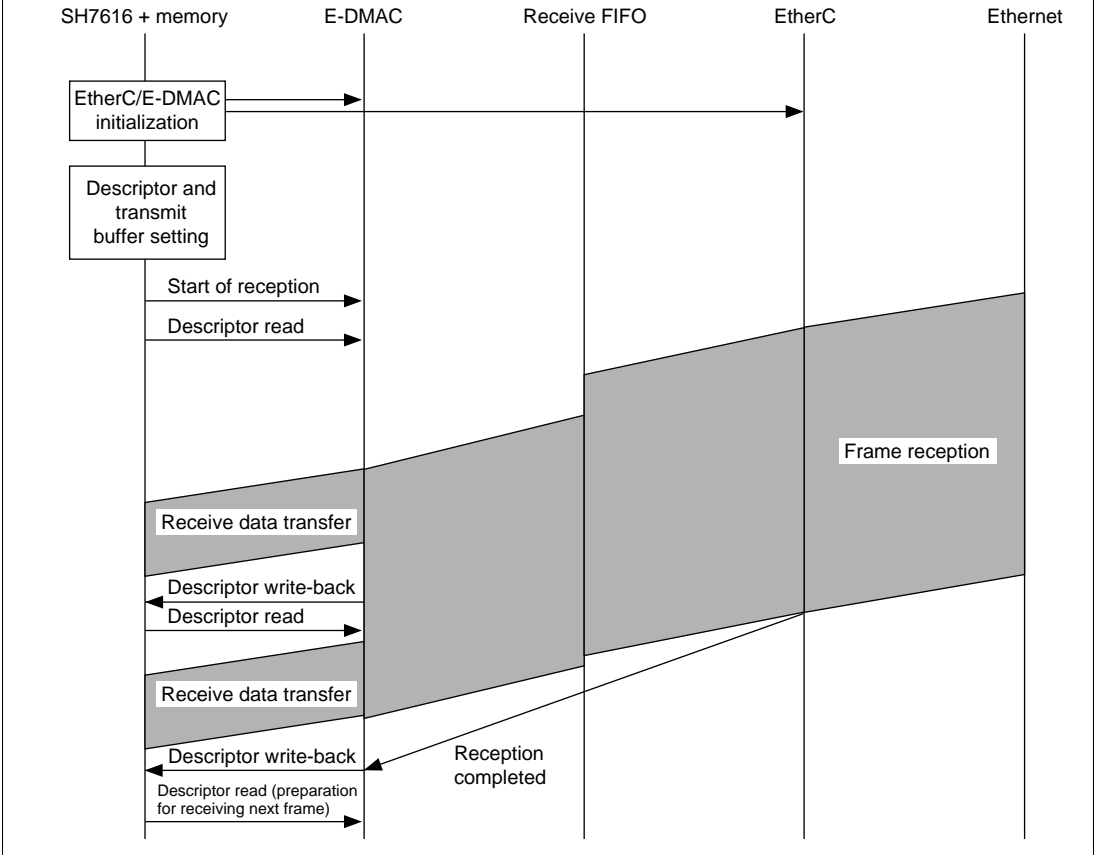

Figure 10.5 Sample Reception Flowchart

10.3.4 Multi-Buffer Frame Transmit/Receive Processing

Multi-Buffer Frame Transmit Processing: If an error occurs during multi-buffer frame transmission, the processing shown in figure 10.6 is carried out.

Where the transmit descriptor is shown as inactive (TACT bit = 0) in the figure, buffer data has already been transmitted normally, and where the transmit descriptor is shown as active (TACT bit = 1), buffer data has not been transmitted. If a frame transmit error occurs in the first descriptor part where the transmit descriptor is active (TACT bit = 1), transmission is halted, and the TACT bit cleared to 0, immediately. The next descriptor is then read, and the position within the transmit frame is determined on the basis of bits TFP1 and TFP0 (continuing [00] or end [01]). In the case of a continuing descriptor, the TACT bit is cleared to 0, only, and the next descriptor is read immediately. If the descriptor is the final descriptor, not only is the TACT bit cleared to 0, but write-back is also performed to the TFE and TFS bits at the same time. Data in the buffer is not transmitted between the occurrence of an error and write-back to the final descriptor. If error interrupts are enabled in the EtherC/E-DMAC status interrupt permission register (EESIPR), an interrupt is generated immediately after the final descriptor write-back.

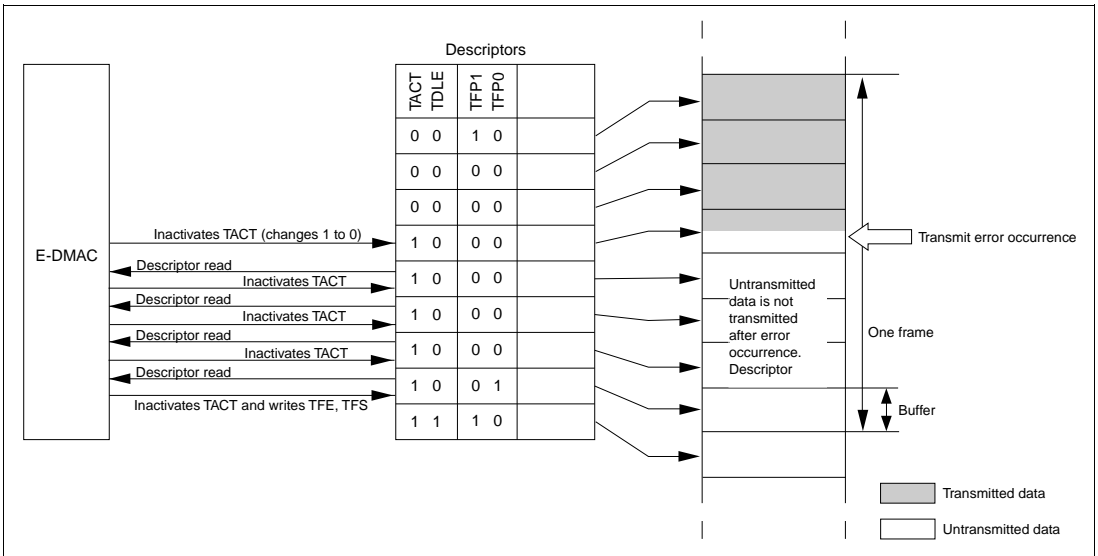

Figure 10.6 E-DMAC Operation after Transmit Error

Multi-Buffer Frame Receive Processing: If an error occurs during multi-buffer frame reception, the processing shown in figure 10.7 is carried out.

Where the receive descriptor is shown as inactive (RACT bit = 0) in the figure, buffer data has already been received normally, and where the receive descriptor is shown as active (RACT bit = 1), this indicates a buffer for which reception has not yet been performed. If a frame receive error

occurs in the first descriptor part where the RACT bit = 1 in the figure, reception is halted immediately and a status write-back to the descriptor is performed.

If error interrupts are enabled in the EtherC/E-DMAC status interrupt permission register (EESIPR), an interrupt is generated immediately after the write-back. If there is a new frame receive request, reception is continued from the buffer after that in which the error occurred.

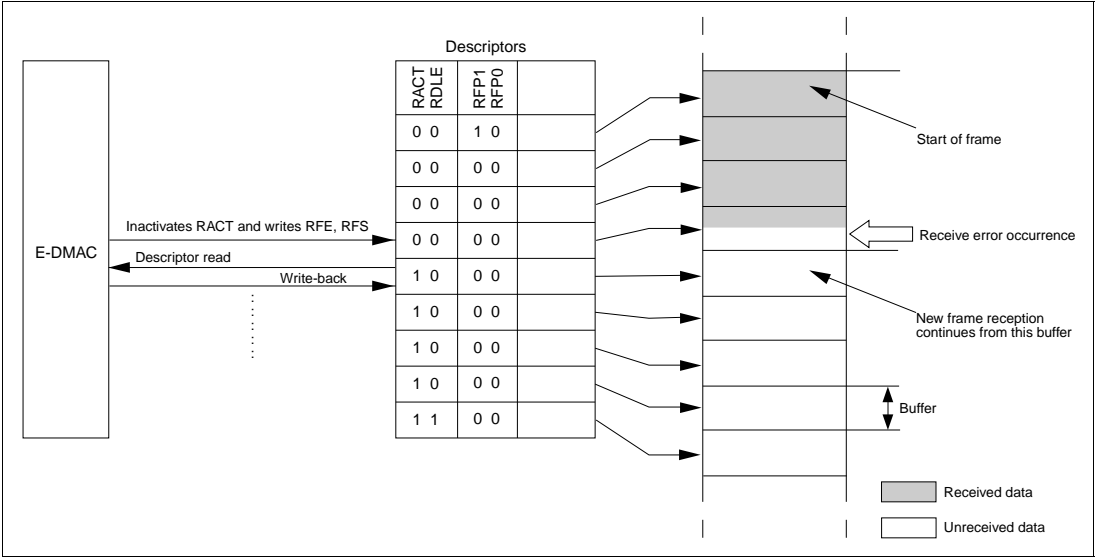

Figure 10.7 E-DMAC Operation after Receive Error

Section 11 Direct Memory Access Controller (DMAC)

11.1 Overview

A two-channel direct memory access controller (DMAC) is included on-chip. The DMAC can be used in place of the CPU to perform high-speed data transfers between external devices equipped with DACK (transfer request acknowledge signal), external memories, on-chip memory, and memory-mapped external devices. Using the DMAC reduces the burden on the CPU and increases the operating efficiency of the chip as a whole.

11.1.1 Features

The DMAC has the following features:

- Two channels
- Address space: Architecturally 4 Gbytes
- Choice of data transfer unit: Byte, word (2-byte), longword (4-byte) or 16-byte unit (In a 16-byte transfer, four longword reads are executed, followed by four longword writes.)
- Maximum of 16,777,216 (16M) transfers
- In the event of a cache hit, CPU instruction processing and DMA operation can be executed in parallel
- Single address mode transfers: Either the transfer source or transfer destination (peripheral device) is accessed by a DACK signal (selectable) while the other is accessed by address. One transfer unit of data is transferred in one bus cycle.

Possible transfer devices: External devices with DACK and memory-mapped external devices (including external memory)

- Dual address mode transfer: Both the transfer source and transfer destination are accessed by address. One transfer unit of data is transferred in two bus cycles.

Possible transfer devices:

- Two external memories
- External memory and memory-mapped external device
- Two memory-mapped external devices
- External memory and on-chip peripheral module (excluding DMAC, BSC, UBC, cache-memory, E-DMAC, and EtherC)
- Memory-mapped external device and on-chip peripheral module (excluding DMAC, BSC, UBC, cache-memory, E-DMAC, and EtherC)
- Two on-chip peripheral modules (excluding DMAC, BSC, UBC, cache-memory, E-DMAC, and EtherC)
- On-chip memory and memory-mapped external device
- Two on-chip memories

- On-chip memory and on-chip peripheral modules (excluding DMAC, BSC, UBC, cache-memory, E-DMAC, and EtherC)
- On-chip memory and external memory
- Transfer requests
 - External request: from the DREQn pins. Edge or level detection, and active-low or active-high mode, can be specified for DREQn.
 - On-chip peripheral module requests: serial communication interface with FIFO (SCIF), 16-bit timer pulse unit (TPU), serial I/O with FIFO (SIOF), serial I/O (SIO)
 - Auto-request: the transfer request is generated automatically within the DMAC
- Choice of bus mode
 - Cycle steal mode
 - Burst mode
- Choice of channel priority order
 - Fixed mode
 - Round robin mode
- An interrupt request can be sent to the CPU on completion of data transfer

11.1.2 Block Diagram

Figure 11.1 shows the DMAC block diagram.

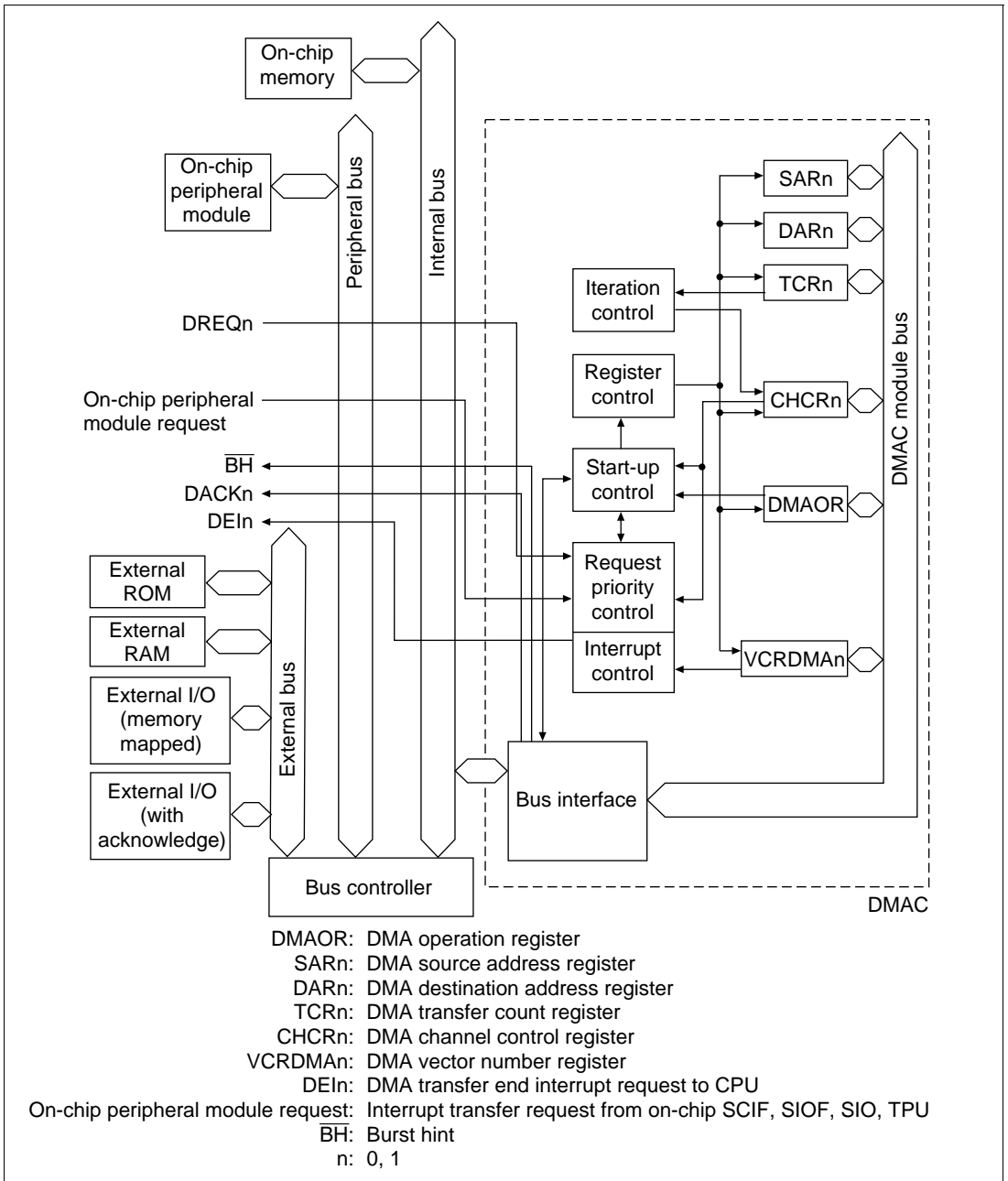

Figure 11.1 DMAC Block Diagram

11.1.3 Pin Configuration

Table 11.1 shows the DMAC pin configuration.

Table 11.1 Pin Configuration

Channel	Name	Symbol	I/O	Function
0	DMA transfer request	DREQ0	I	DMA transfer request input from external device to channel 0
	DMA transfer request acknowledge	DACK0	O	DMA transfer request acknowledge output from channel 0 to external device
1	DMA transfer request	DREQ1	I	DMA transfer request input from external device to channel 1
	DMA transfer request acknowledge	DACK1	O	DMA transfer request acknowledge output from channel 1 to external device
All	Burst hint	$\overline{\text{BH}}$	O	Burst transfer in 16-byte transfer mode

11.1.4 Register Configuration

Table 11.2 summarizes the DMAC registers. The DMAC has a total of 13 registers. Each channel has six control registers. One control register is shared by both channels.

Table 11.2 Register Configuration

Channel Name		Abbr.	R/W	Initial Value	Address	Access Size* ³
0	DMA source address register 0	SAR0	R/W	Undefined	H'FFFFFFF80	32
	DMA destination address register 0	DAR0	R/W	Undefined	H'FFFFFFF84	32
	DMA transfer count register 0	TCR0	R/W	Undefined	H'FFFFFFF88	32
	DMA channel control register 0	CHCR0	R/(W)* ¹	H'00000000	H'FFFFFFF8C	32
	DMA vector number register 0	VCRDMA0	R/W	Undefined	H'FFFFFFFA0	32
	DMA request/response selection control register 0	DRCR0	R/W	H'00	H'FFFFFFE71	8* ³
1	DMA source address register 1	SAR1	R/W	Undefined	H'FFFFFFF90	32
	DMA destination address register 1	DAR1	R/W	Undefined	H'FFFFFFF94	32
	DMA transfer count register 1	TCR1	R/W	Undefined	H'FFFFFFF98	32
	DMA channel control register 1	CHCR1	R/(W)* ¹	H'00000000	H'FFFFFFF9C	32
	DMA vector number register 1	VCRDMA1	R/(W)	Undefined	H'FFFFFFFA8	32
	DMA request/response selection control register 1	DRCR1	R/(W)	H'00	H'FFFFFFE72	8* ³
All	DMA operation register	DMAOR	R/(W)* ²	H'00000000	H'FFFFFFFB0	32

Notes: *1 Only 0 can be written to bit 1 of CHCR0 and CHCR1, after reading 1, to clear the flags.

*2 Only 0 can be written to bits 1 and 2 of the DMAOR, after reading 1, to clear the flags.

*3 Access DRCR0 and DRCR1 in byte units. Access all other registers in longword units.

11.2 Register Descriptions

11.2.1 DMA Source Address Registers 0 and 1 (SAR0, SAR1)

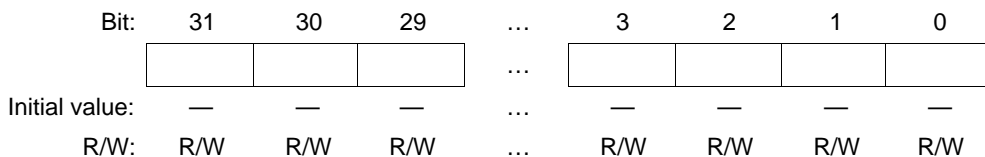

DMA source address registers 0 and 1 (SAR0 and SAR1) are 32-bit read/write registers that specify the source address of a DMA transfer. During a DMA transfer, these registers indicate the next source address. (In single-address mode, SAR is ignored in transfers from external devices with DACK to memory-mapped external devices or external memory). In 16-byte unit transfers, always set the value of the source address to a 16-byte boundary (16n address). Operation results cannot be guaranteed if other values are used. Transmission in 16-byte units can be set only in auto-request mode and at edge detection in external request mode. Values are retained in a reset, in standby mode, and when the module standby function is used.

11.2.2 DMA Destination Address Registers 0 and 1 (DAR0, DAR1)

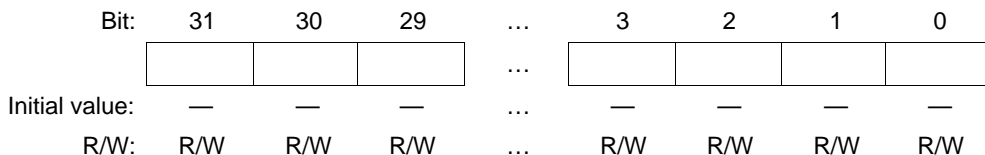

DMA destination address registers 0 and 1 (DAR0 and DAR1) are 32-bit read/write registers that specify the destination address of a DMA transfer. During a DMA transfer, these registers indicate the next destination address. (In single-address mode, DAR is ignored in transfers from memory-mapped external devices or external memory to external devices with DACK). In 16-byte unit transfers, always set the value of the source address to a 16-byte boundary (16n address). Operation results cannot be guaranteed if other values are used. Transmission in 16-byte units can be set only in auto-request mode and at edge detection in external request mode. Values are retained in a reset, in standby mode, and when the module standby function is used.

If synchronous DRAM is accessed when performing 16-byte-unit transfer, a 16-byte boundary (address 16n) value must be set for the destination address.

11.2.3 DMA Transfer Count Registers 0 and 1 (TCR0, TCR1)

Bit:	31	30	29	28	27	26	25	24
	—	—	—	—	—	—	—	—
Initial value:	0	0	0	0	0	0	0	0
R/W:	R	R	R	R	R	R	R	R
Bit:	23	22	21	...	3	2	1	0
				...				
Initial value:	—	—	—	...	—	—	—	—
R/W:	R/W	R/W	R/W	...	R/W	R/W	R/W	R/W

DMA transfer count registers 0 and 1 (TCR0 and TCR1) are 32-bit read/write registers that specify the DMA transfer count. The lower 24 of the 32 bits are valid. The value is written as 32 bits, including the upper eight bits. The number of transfers is 1 when the setting is H'00000001, 16,777,215 when the setting is H'00FFFFFF and 16, 777,216 (the maximum) when H'00000000 is set. During a DMA transfer, these registers indicate the remaining transfer count.

Set the initial value as the write value in the upper eight bits. These bits always read 0. Values are retained in a reset, in standby mode, and when the module standby function is used. For 16-byte transfers, set the count to 4 times the number of transfers. Operation is not guaranteed if an incorrect value is set.

11.2.4 DMA Channel Control Registers 0 and 1 (CHCR0, CHCR1)

Bit:	31	30	29	...	19	18	17	16
	—	—	—	...	—	—	—	—
Initial value:	0	0	0	...	0	0	0	0
R/W:	R	R	R	...	R	R	R	R
Bit:	15	14	13	12	11	10	9	8
	DM1	DM0	SM1	SM0	TS1	TS0	AR	AM
Initial value:	0	0	0	0	0	0	0	0
R/W:	R/W	R/W	R/W	R/W	R/W	R/W	R/W	R/W
Bit:	7	6	5	4	3	2	1	0
	AL	DS	DL	TB	TA	IE	TE	DE
Initial value:	0	0	0	0	0	0	0	0
R/W:	R/W	R/W	R/W	R/W	R/W	R/W	R/(W)*	R/W

Note: Only 0 can be written, to clear the flag.

DMA channel control registers 0 and 1 (CHCR0 and CHCR1) are 32-bit read/write registers that control the DMA transfer mode. They also indicate the DMA transfer status. Only the lower 16 of the 32 bits are valid. They should be read and written as 32-bit values, including the upper 16 bits. The registers are initialized to H'00000000 by a reset and in standby mode. Values are retained during a module standby.

Bits 31 to 16—Reserved: These bits are always read as 0. The write value should always be 0.

Bits 15 and 14—Destination Address Mode Bits 1, 0 (DM1, DM0): Select whether the DMA destination address is incremented, decremented or left fixed (in single address mode, DM1 and DM0 are ignored when transfers are made from a memory-mapped external device, or external memory to an external device with DACK). DM1 and DM0 are initialized to 00 by a reset and in standby mode. Values are retained during a module standby.

Bit 15: DM1	Bit 14: DM0	Description
0	0	Fixed destination address (Initial value)
	1	Destination address is incremented (+1 for byte transfer size, +2 for word transfer size, +4 for longword transfer size, +16 for 16-byte transfer size)
1	0	Destination address is decremented (−1 for byte transfer size, −2 for word transfer size, −4 for longword transfer size, −16 for 16-byte transfer size)
	1	Reserved (setting prohibited)

Bits 13 and 12—Source Address Mode Bits 1, 0 (SM1, SM0): Select whether the DMA source address is incremented, decremented or left fixed. (In single address mode, SM1 and SM0 are ignored when transfers are made from an external device with DACK to a memory-mapped external device, or external memory.) For a 16-byte transfer, the address is incremented by +16 regardless of the SM1 and SM0 values. SM1 and SM0 are initialized to 00 by a reset and in standby mode. Values are retained during a module standby.

Bit 13: SM1	Bit 12: SM0	Description
0	0	Fixed source address (+16 for 16-byte transfer size) (Initial value)
	1	Source address is incremented (+1 for byte transfer size, +2 for word transfer size, +4 for longword transfer size, +16 for 16-byte transfer size)
1	0	Source address is decremented (−1 for byte transfer size, −2 for word transfer size, −4 for longword transfer size, +16 for 16-byte transfer size)
	1	Reserved (setting prohibited)

Bits 11 and 10—Transfer Size Bits (TS1, TS0): Select the DMA transfer size. When 11 is set to bits TS1 and TS0 (in the 16-byte unit), request mode is available only in auto-request mode and at edge detection in external request mode. When 11 is set to bits TS1 and TS0 (in the 16-byte unit) and level detection in external request mode and internal peripheral-module request mode are set, system operations are not guaranteed. TS1 and TS0 are initialized to 00 by a reset and in standby mode. Values are retained during a module standby.

Bit 11: TS1	Bit 10: TS0	Description
0	0	Byte unit* (initial value)
	1	Word (2-byte) unit
1	0	Longword (4-byte) unit
	1	16-byte unit (4 longword transfers)

Note: * The byte unit setting should not be used if a destination address has been set in internal memory for the dual address mode.

Bit 9—Auto Request Mode Bit (AR): Selects either auto-request mode (in which transfer requests are generated automatically within the DMAC) or a mode using external requests or requests from on-chip peripheral modules (SCIF, TPU, SIOF, SIO). The AR bit is initialized to 0 by a reset and in standby mode. Its value is retained during a module standby.

Bit 9: AR	Description
0	External/on-chip peripheral module request mode (Initial value)
1	Auto-request mode

Bit 8—Acknowledge/Transfer Mode Bit (AM): In dual address mode, this bit selects whether the DACKn signal is output during the data read cycle or write cycle. In single-address mode, it selects whether to transfer data from memory to device or from device to memory. The AM bit is initialized to 0 by a reset and in standby mode. Its value is retained during a module standby.

Bit 8: AM	Description
0	DACKn output in read cycle (dual address mode)/transfer from memory to device (single address mode) (Initial value)
1	DACKn output in write cycle (dual address mode)/transfer from device to memory (single address mode)

Bit 7—Acknowledge Level Bit (AL): Selects whether the DACKn signal is an active-high signal or an active-low signal. The AL bit is initialized to 0 by a reset and in standby mode. Its value is retained during a module standby.

Bit 7: AL	Description
0	DACKn is an active-low signal (Initial value)
1	DACKn is an active-high signal

Bit 6—DREQn Select Bit (DS): Selects the DREQn input detection used. When 0 (level detection) is set to bit DS, set 0 (cycle-steal mode) to the transfer bus mode bit (TB). When 0 is set to bit DS and 1 (burst mode) is set to bit TB, system operations are not guaranteed. The DS bit is initialized to 0 by a reset and in standby mode. Its value is retained during a module standby.

Bit 6: DS	Description
0	Detected by level (Initial value) Can be set only in cycle-steal mode
1	Detected by edge

Bit 5—DREQn Level Bit (DL): Selects the DREQn input detection level. The DL bit is initialized to 0 by a reset and in standby mode. Its value is retained during a module standby.

Bit 5: DL	Description
0	When DS is 0, DREQ is detected by low level; when DS is 1, DREQ is detected at falling edge (Initial value)
1	When DS is 0, DREQ is detected by high level; when DS is 1, DREQ is detected at rising edge

Bit 4—Transfer Bus Mode Bit (TB): Selects the bus mode for DMA transfers. When 1 (burst mode) is set to bit TB, set 1 (edge detection) to the DREQ select bit (DS). When 1 is set to bit TB and 0 (level detection) is set to bit DS, system operations are not guaranteed. The TB bit is initialized to 0 by a reset and in standby mode. Its value is retained during a module standby.

Bit 4: TB	Description
0	Cycle-steal mode (Initial value)
1	Burst mode

Bit 3—Transfer Address Mode Bit (TA): Selects the DMA transfer address mode. The TA bit is initialized to 0 by a reset and in standby mode. Its value is retained during a module standby.

Bit 3: TA	Description
0	Dual address mode (Initial value)
1	Single address mode

Bit 2—Interrupt Enable Bit (IE): Determines whether or not to request a CPU interrupt at the end of a DMA transfer. When the IE bit is set to 1, an interrupt (DEI) request is sent to the CPU when the TE bit is set. The IE bit is initialized to 0 by a reset and in standby mode. Its value is retained during a module standby.

Bit 2: IE	Description
0	Interrupt request disabled (Initial value)
1	Interrupt request enabled

Bit 1—Transfer-End Flag Bit (TE): Indicates that the transfer has ended. When the value in the DMA transfer count register (TCR) becomes 0, the DMA transfer ends normally and the TE bit is set to 1. When TCR is not 0, the TE bit is not set if the transfer ends because of an NMI interrupt or DMA address error, or because the DME bit in the DMA operation register (DMAOR) or the DE bit was cleared. To clear the TE bit, read 1 from it and then write 0. When the TE bit is set, setting the DE bit to 1 will not enable a transfer. The TE bit is initialized to 0 by a reset and in standby mode. Its value is retained during a module standby.

Bit 1: TE	Description
0	DMA has not ended or was aborted (Initial value) Cleared by reading 1 from the TE bit and then writing 0
1	DMA has ended normally (by TCR = 0)

Bit 0—DMA Enable Bit (DE): Enables or disables DMA transfers. In auto-request mode, the transfer starts when this bit or the DME bit in DMAOR is set to 1. The NMIF and AE bits in DMAOR and the TE bit must be all set to 0. In external request mode or on-chip peripheral module request mode, the transfer begins when the DMA transfer request is received from the relevant device or on-chip peripheral module, provided this bit and the DME bit are set to 1. As with the auto-request mode, the TE bit and the NMIF and AE bits in DMAOR must all be set to 0. The transfer can be stopped by clearing this bit to 0. The DE bit is initialized to 0 by a reset and in standby mode. Its value is retained during a module standby.

Bit 0: DE	Description
0	DMA transfer disabled (Initial value)
1	DMA transfer enabled

11.2.5 DMA Vector Number Registers 0 and 1 (VCRDMA0, VCRDMA1)

Bit:	31	30	29	...	11	10	9	8
	—	—	—	...	—	—	—	—
Initial value:	0	0	0	...	0	0	0	0
R/W:	R	R	R	...	R	R	R	R
Bit:	7	6	5	4	3	2	1	0
	VC7	VC6	VC5	VC4	VC3	VC2	VC1	VC0
Initial value:	—	—	—	—	—	—	—	—
R/W:	R/W	R/W	R/W	R/W	R/W	R/W	R/W	R/W

DMA vector number registers 0 and 1 (VCRDMA0, VCRDMA1) are 32-bit read/write registers that set the DMAC transfer-end interrupt vector number. Only the lower eight bits of the 32 are valid. They are written as 32-bit values, including the upper 24 bits. Values are retained in a reset, in standby mode, and when the module standby function is used.

Bits 31 to 8—Reserved: These bits are always read as 0. The write value should always be 0.

Bits 7 to 0—Vector Number Bits 7–0 (VC7–VC0): Set the interrupt vector numbers at the end of a DMAC transfer. Interrupt vector numbers of 0–127 can be set. When a transfer-end interrupt occurs, the vector number is fetched and control is transferred to the specified interrupt handling routine. The VC7–VC0 bits retain their values in a reset and in standby mode. As the maximum vector number is 127, 0 must always be written to VC7.

11.2.6 DMA Request/Response Selection Control Registers 0 and 1 (DRCR0, DRCR1)

Bit:	7	6	5	4	3	2	1	0
	—	—	—	RS4	RS3	RS2	RS1	RS0
Initial value:	0	0	0	0	0	0	0	0
R/W:	R	R	R	R/W	R/W	R/W	R/W	R/W

DMA request/response selection control registers 0 and 1 (DRCR0, DRCR1) are 8-bit read/write registers that set the DMAC transfer request source. They are written as 8-bit values. They are initialized to H'00 by a reset, but retain their values in standby mode and a module standby.

Bits 7 to 5—Reserved: These bits are always read as 0. The write value should always be 0.

Bits 4 to 0—Resource Select Bits 4 to 0 (RS4–RS0): Specify which transfer request to input to the DMAC. Changing the transfer request source must be done when the DMA enable bit (DE) is 0. See section 11.3.4, DMA Transfer Types, for the possible setting combinations.

Bits RS4 to RS0 are initialized to 001 by a reset.

Bit 4: RS4	Bit 3: RS3	Bit 2: RS2	Bit 1: RS1	Bit 0: RS0	Description
0	0	0	0	0	DREQ (external request) (Initial value)
				1	Reserved (setting prohibited)
			1	0	Reserved (setting prohibited)
				1	Reserved (setting prohibited)
	1	0	0	0	Reserved (setting prohibited)
				1	SCIF channel 1 RXI (on-chip SCI with FIFO channel 1 receive-data-full interrupt request)*
		1	0	0	SCIF channel 1 TXI (on-chip SCI with FIFO channel 1 transmit-data-empty interrupt request)*
	1	1	1	1	Reserved (setting prohibited)

Bit 4: RS4	Bit 3: RS3	Bit 2: RS2	Bit 1: RS1	Bit 0: RS0	Description			
0	1	0	0	0	Reserved (setting prohibited)			
				1	SCIF channel 2 RXI (on-chip SCI with FIFO channel 2 receive-data-full interrupt request)*			
			1	0	SCIF channel 2 TXI (on-chip SCI with FIFO channel 2 transmit-data-empty interrupt request)*			
				1	Reserved (setting prohibited)			
	0	1	0	0	TPU TGI0A (TPU input capture channel 0A interrupt request)*			
				1	TPU TGI0B (TPU input capture channel 0B interrupt request)*			
		0	0	1	0	TPU TGI0C (TPU input capture channel 0C interrupt request)*		
					1	TPU TGI0D (TPU input capture channel 0D interrupt request)*		
			1	0	0	0	0	Reserved (setting prohibited)
							1	SIOF RDFI (SIO with FIFO receive-data-full interrupt request)*
1	0	0				SIOF TDEI (SIO with FIFO transmit-data-empty interrupt request)*		
		1				Reserved (setting prohibited)		
1	0	0		0	Reserved (setting prohibited)			
				1	SIO channel 1 RDFI (SIO channel 1 receive-data-full interrupt request)*			
	1	0		0	SIO channel 1 TDEI (SIO channel 1 transmit-data-empty interrupt request)*			
				1	Reserved (setting prohibited)			
1	0	0	0	Reserved (setting prohibited)				
			1	SIO channel 2 RDFI (SIO channel 2 receive-data-full interrupt request)*				
	1	0	0	SIO channel 2 TDEI (SIO channel 2 transmit-data-empty interrupt request)*				
			1	Reserved (setting prohibited)				
			1	Reserved (setting prohibited)				
1	*	*	*	Reserved (setting prohibited)				

Note: * When a transfer request is generated by an on-chip module, select cycle-steal as the bus mode, dual transfer as the transfer mode, and falling edge detection for the DREQn setting.

11.2.7 DMA Operation Register (DMAOR)

Bit:	31	30	29	...	11	10	9	8
	—	—	—	...	—	—	—	—
Initial value:	0	0	0	...	0	0	0	0
R/W:	R	R	R	...	R	R	R	R
Bit:	7	6	5	4	3	2	1	0
	—	—	—	—	PR	AE	NMIF	DME
Initial value:	0	0	0	0	0	0	0	0
R/W:	R	R	R	R	R/W	R/(W)*	R/(W)*	R/W

Note: * Only 0 can be written, to clear the flag.

The DMA operation register (DMAOR) is a 32-bit read/write register that controls the DMA transfer mode. It also indicates the DMA transfer status. Only the lower four of the 32 bits are valid. DMAOR is written as a 32-bit value, including the upper 28 bits. DMAOR is initialized to H'00000000 by a reset and in standby mode. It retains its value when the module standby function is used.

Bits 31 to 4—Reserved: These bits are always read as 0. The write value should always be 0.

Bit 3—Priority Mode Bit (PR): Specifies whether a fixed channel priority order or round-robin mode is to be used there are simultaneous transfer requests for multiple channels. It is initialized to 0 by a reset and in standby mode. It retains its value when the module standby function is used.

Bit 3: PR	Description
0	Fixed priority (channel 0 > channel 1) (Initial value)
1	Round-robin (Top priority shifts to bottom after each transfer. The priority for the first DMA transfer after a reset is channel 1 > channel 0)

Bit 2—Address Error Flag Bit (AE): This flag indicates that an address error has occurred in the DMAC. When the AE bit is set to 1, DMA transfer cannot be enabled even if the DE bit in the DMA channel control register (CHCR) is set to 1. To clear the AE bit, read 1 from it and then write 0. Operation is performed up to the DMAC transfer being executed when the address error occurred. AE is initialized to 0 by a reset and in standby mode. It retains its value when the module standby function is used.

Bit 2: AE	Description	
0	No DMAC address error To clear the AE bit, read 1 from it and then write 0	(Initial value)
1	Address error by DMAC	

Bit 1—NMI Flag Bit (NMIF): This flag indicates that an NMI interrupt has occurred. When the NMIF bit is set to 1, DMA transfer cannot be enabled even if the DE bit in the DMA channel control register (CHCR) and the DME bit are set to 1. To clear the NMIF bit, read 1 from it and then write 0. Operation is completed up to the end of the DMAC transfer being executed when NMI was input. When the NMI interrupt is input while the DMAC is not operating, the NMIF bit is set to 1. The NMIF bit is initialized to 0 by a reset or in the standby mode. It retains its value when the module standby function is used.

Bit 1: NMIF	Description	
0	No NMIF interrupt To clear the NMIF bit, read 1 from it and then write 0	(Initial value)
1	NMIF interrupt has occurred	

Bit 0—DMA Master Enable Bit (DME): Enables or disables DMA transfers on all channels. A DMA transfer becomes enabled when the DE bit in the CHCR and the DME bit are set to 1. For this to be effective, the TE bit in CHCR and the NMIF and AE bits must all be 0. When the DME bit is cleared, all channel DMA transfers are aborted. DME is initialized to 0 by a reset and in standby mode. It retains its value when the module standby function is used.

Bit 0: DME	Description	
0	DMA transfers disabled on all channels	(Initial value)
1	DMA transfers enabled on all channels	

11.3 Operation

When there is a DMA transfer request, the DMAC starts the transfer according to the predetermined channel priority; when the transfer-end conditions are satisfied, it ends the transfer. Transfers can be requested in three modes: auto-request, external request, and on-chip module request. A transfer can be in either single address mode or dual address mode. The bus mode can be either burst or cycle-steal.

11.3.1 DMA Transfer Flow

After the DMA source address registers (SAR), DMA destination address registers (DAR), DMA transfer count registers (TCR), DMA channel control registers (CHCR), DMA vector number registers (VCRDMA), DMA request/response selection control registers (DRCR), and DMA operation register (DMAOR) are initialized (initializing sets each register so that ultimately the condition (DE = 1, DME = 1, TE = 0, NMIF = 0, AE = 0) is satisfied), the DMAC transfers data according to the following procedure:

1. Checks to see if transfer is enabled (DE = 1, DME = 1, TE = 0, NMIF = 0, AE = 0)
2. When a transfer request occurs and transfer is enabled, the DMAC transfers 1 transfer unit of data. (In auto-request mode, the transfer begins automatically after register initialization. The TCR value will be decremented by 1.) The actual transfer flows vary depending on the address mode and bus mode.
3. When the specified number of transfers have been completed (when TCR reaches 0), the transfer ends normally. If the IE bit in CHCR is set to 1 at this time, a DEI interrupt request is sent to the CPU.
4. When an address error occurs in the DMAC or an NMI interrupt is generated, the transfer is aborted. Transfers are also aborted when the DE bit in CHCR or the DME bit in DMAOR is changed to 0.

Figure 11.2 shows a flowchart illustrating this procedure.

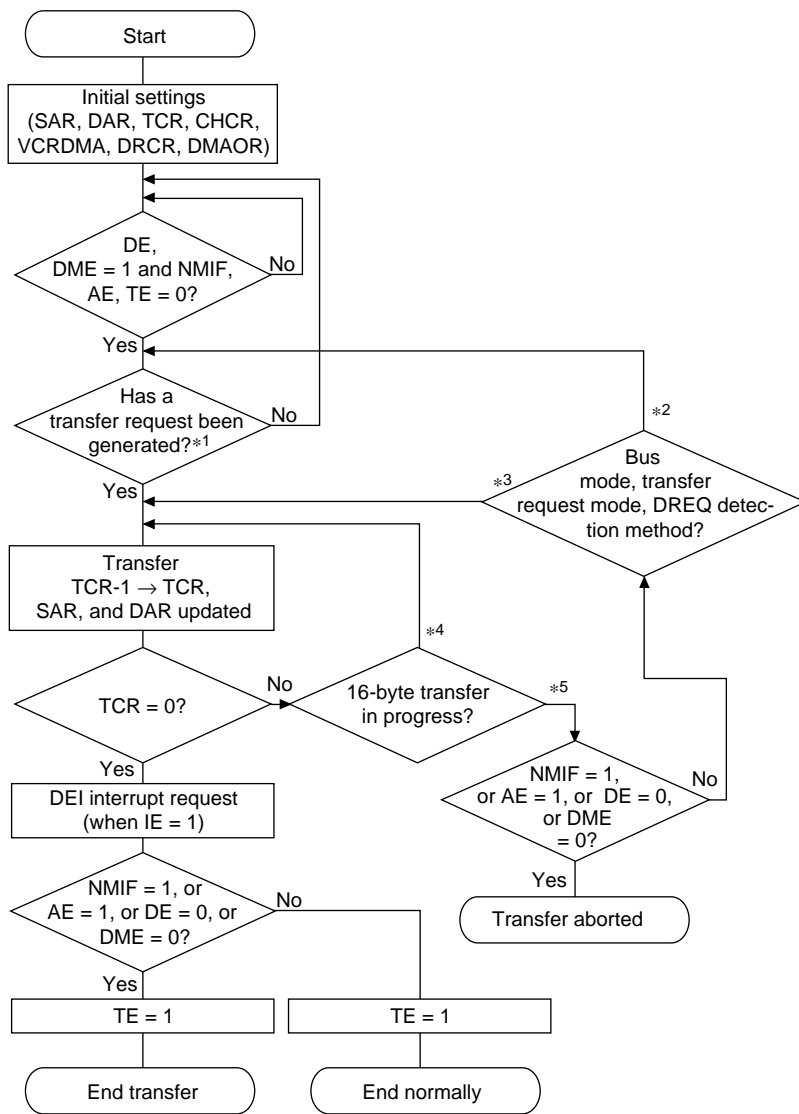

Notes: *1 In auto-request mode, the transfer will start when the NMIF, AE, and TE bits are all 0 and the DE and DME bits are then set to 1.

*2 Cycle-steal mode.

*3 In burst mode, DREQ = edge detection (external request), or auto-request mode in burst mode.

*4 16-byte transfer cycle in progress.

*5 End of a 16-byte transfer cycle.

Figure 11.2 DMA Transfer Flow

11.3.2 DMA Transfer Requests

DMA transfer requests are usually generated in either the data transfer source or destination, but they can also be generated by devices that are neither the source nor the destination. Transfers can be requested in three modes: auto-request, external request, and on-chip peripheral module request. The request mode is selected with the AR bit in DMA channel control registers 0 and 1 (CHCR0, CHCR1) and the RS0, RS1, RS2, RS3 and RS4 bits in DMA request/response selection control registers 0 and 1 (DRCR0, DRCR1).

Table 11.3 Selecting the DMA Transfer Request Using the AR and RS Bits

CHCR		DRCR				Request Mode	Resource Selection						
AR	RS4	RS3	RS2	RS1	RS0								
0	0	0	0	0	0	Module request mode	DREQ (external request)						
				1	0		1	SCIF channel 1 RXI					
					1		0	SCIF channel 1 TXI					
			1	0	0	0	0	1	SCIF channel 2 RXI				
							1	0	SCIF channel 2 TXI				
							1	0			TPU TGI0A		
				1	TPU TGI0B								
			1	0	0	0	1	0	TPU TGI0C				
								1	TPU TGI0D				
			1	0	0	0	0		SIOF RDFI				
								1	0	SIOF TDEI			
							1	0	1	0	1	1	SIO channel 1 RDFI
												1	0
							1	0	0	0	0	1	SIO channel 2 RDFI
	1	0									SIO channel 2 TDEI		
1	*	*	*	*	*	Auto-request mode							

Note: * Don't care

Auto-Request Mode: When there is no transfer request signal from an external source (as in a memory-to-memory transfer, the auto-request mode allows the DMAC to automatically generate a transfer request signal internally. When the DE bits in CHCR0 and CHCR1 and the DME bit in the DMA operation register (DMAOR) are set to 1, the transfer begins (so long as the TE bits in CHCR0 and CHCR1 and the NMIF and AE bits in DMAOR are all 0).

External Request Mode: In this mode a transfer is started by a transfer request signal (DREQn) from an external device. Choose one of the modes shown in table 11.4 according to the application system. When DMA transfer is enabled (DE = 1, DME = 1, TE = 0, NMIF = 0, AE = 0), a transfer is performed upon input of a DREQn signal.

Table 11.4 Selecting External Request Modes with the TA and AM Bits

CHCR		Transfer			
TA	AM	Address Mode	Acknowledge Mode	Source	Destination
0	0	Dual address mode	DACKn output in read cycle	Any*	Any*
	1	Dual address mode	DACKn output in write cycle	Any*	Any*
1	0	Single address mode	Data transferred from memory to device	External memory or memory-mapped external device	External device with DACK
	1	Single address mode	Data transferred from device to memory	External device with DACK	External memory or memory-mapped external device

Note: * External memory, memory-mapped external device, and on-chip peripheral module (excluding DMAC, BSC, UBC, cache memory, E-DMAC, and EtherC).

Choose to detect DREQn either by the falling edge or by level using the DS and DL bits in CHCR0 and CHCR1 (DS = 0 is level detection, DS = 1 is edge detection; DL = 0 is active-low, DL = 1 is active-high). The source of the transfer request does not have to be the data transfer source or destination.

When 0 (level detection) is set to the DS bit of CHCR0 and CHCR1, set the TB bit to 0 (cycle-steal mode) and set the TS1 and TS0 bits of CHCR0 and CHCR1 to either 00 (byte unit), 01 (word unit), or 10 (long word unit).

When 0 is set to the DS bit of CHCR0 and CHCR1, when 1 (burst mode) is set to the TB bit of CHCR0 and CHCR1, and when 11 (16 byte unit) is set to the TS1 and TS0 bits of CHCR1 and CHCR1, operation is not guaranteed.

Table 11.5 Selecting the External Request Signal with the DS and DL Bits

CHCR		
DS	DL	External Request
0	0	Low-level detection (can only be set in cycle-steal mode)
	1	High-level detection (can only be set in cycle-steal mode)
1	0	Falling-edge detection
	1	Rising-edge detection

On-Chip Module Request Mode: In this mode, transfers are started by a transfer request signal (interrupt request signal) from an on-chip peripheral module. Transfer request signals include SCIF, SIOF or SIO receive-data-full interrupts (RXI, RDFI), SCIF, SIOF or SIO transmit-data-empty interrupts (TXI, TDEI), and TPU general registers (table 11.6). If DMA transfer is enabled (DE = 1, DME = 1, TE = 0, NMIF = 0, AE = 0), DMA transfer starts upon input of a transfer request signal.

When RXI or RDFI (transfer request due to an SCIF, SIOF or SIO receive-data-full condition) is set as a transfer request, the transfer source must be the receive data register of the corresponding module (SCFRDR or SIRDR). When TXI or TDEI (transfer request due to an SCIF, SIOF or SIO transmit-data-empty condition) is set as a transfer request, the transfer destination must be the transmit data register of the corresponding module (SCFTDR or SITDR).

These restrictions do not apply to TPU transfer requests.

When on-chip module request mode is used, an access size permitted by the peripheral module register used as the transfer source or transfer destination must be set in bits TS1 and TS0 of CHCR0 and CHCR1.

Table 11.6 Selecting On-Chip Peripheral Module Request Mode with the AR and RS Bits

AR	RS4	RS3	RS2	RS1	RS0	DMA Transfer Request Source	DMA Transfer Request Signal	Transfer Source	Transfer Destination	Bus Mode	DREQ Setting	
0	0	0	1	0	1	SCIF channel 1 receiver	RXI	SCFRDR1	Any	Cycle-steal	Edge, active-low	
					0	SCIF channel 1 transmitter	TXI	Any	SCFTDR1	Cycle-steal	Edge, active-low	
	1	0	0	1	0	SCIF channel 2 receiver	RXI	SCFRDR2	Any	Cycle-steal	Edge, active-low	
					0	SCIF channel 2 transmitter	TXI	Any	SCFTDR2	Cycle-steal	Edge, active-low	
		1	0	0	0	TPU channel 0A	TGI0A	Any (excluding on-chip RAM)	Any (excluding on-chip RAM)	Cycle-steal	Edge, active-low	
					1	TPU channel 0B	TGI0B	Any (excluding on-chip RAM)	Any (excluding on-chip RAM)	Cycle-steal	Edge, active-low	
					1	TPU channel 0C	TGI0C	Any (excluding on-chip RAM)	Any (excluding on-chip RAM)	Cycle-steal	Edge, active-low	
					1	TPU channel 0D	TGI0D	Any (excluding on-chip RAM)	Any (excluding on-chip RAM)	Cycle-steal	Edge, active-low	
	1	0	0	0	1	SIOF receiver	RDFI	SIRDR	Any	Cycle-steal	Edge, active-low	
					0	SIOF transmitter	TDEI	Any	SITDR	Cycle-steal	Edge, active-low	
		1	0	0	1	0	SIO channel 1 receiver	RDFI	SIRDR1	Any	Cycle-steal	Edge, active-low
						0	SIO channel 1 transmitter	TDEI	Any	SITDR1	Cycle-steal	Edge, active-low
0						SIO channel 2 receiver	RDFI	SIRDR2	Any	Cycle-steal	Edge, active-low	
0						SIO channel 2 transmitter	TDEI	Any	SITDR2	Cycle-steal	Edge, active-low	

For outputting transfer request from the SCIF, SIOF, SIO, and TPU, the corresponding interrupt enable bits must be set to output the interrupt signals. Note that transfer request signals from on-chip peripheral modules (interrupt request signals) are sent not just to the DMAC but to the CPU as well. When an on-chip peripheral module is specified as the transfer request source, set the priority level values in the interrupt priority level registers (IPRC–IPRE) of the interrupt controller (INTC) at or below the levels set in the I3–I0 bits of the CPU’s status register so that the CPU does not accept the interrupt request signal.

With the DMA transfer request signals in table 11.6, when DMA transfer is performed a DMA transfer request (interrupt request) from any module will be cleared at the first transfer.

11.3.3 Channel Priorities

When the DMAC receives simultaneous transfer requests on two channels, it selects a channel according to a predetermined priority order. There is a choice of two priority modes, fixed or round-robin. The mode is selected by the priority bit, PR, in the DMA operation register (DMAOR).

Fixed Priority Mode: In this mode, the relative channel priority levels are fixed. When PR is set to 0, channel 0 has higher priority than channel 1. Figure 11.3 shows an example of a transfer in burst mode.

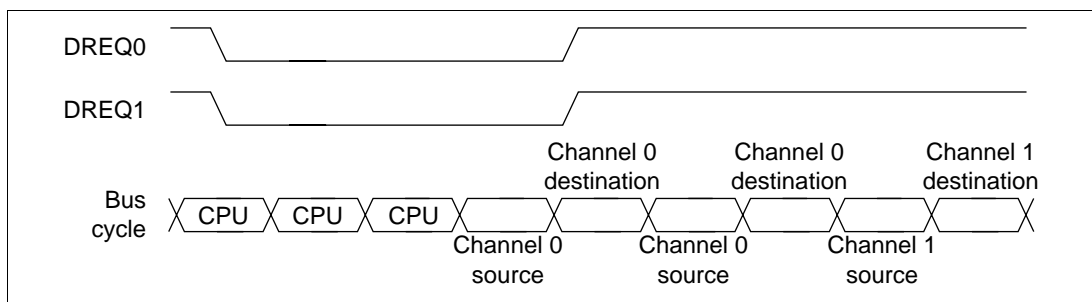

**Figure 11.3 Fixed Mode DMA Transfer in Burst Mode
(Dual Address, DREQn Falling-Edge Detection)**

In cycle-steal mode, once a channel 0 request is accepted, channel 1 requests are also accepted until the next request is accepted, which makes more effective use of the bus cycle. If requests come simultaneously for channel 0 and channel 1 when DMA operation is starting, the first is transmitted with channel 0, and thereafter channel 1 and channel 0 transfers are performed alternately.

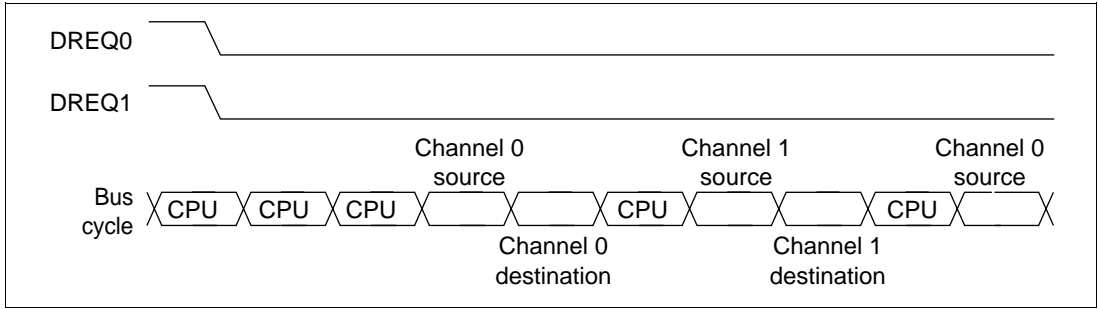

**Figure 11.4 Fixed Mode DMA Transfer in Cycle-Steal Mode
(Dual Address, DREQn Low-Level Detection)**

Round-Robin Mode: Switches the priority of channel 0 and channel 1, shifting their ability to receive transfer requests. Each time one transfer ends on one channel, the priority shifts to the other channel. The channel on which the transfer just finished is assigned low priority. After reset, channel 1 has higher priority than channel 0.

Figure 11.5 shows how the priority changes when channel 0 and channel 1 transfers are requested simultaneously and another channel 0 transfer is requested after the first two transfers end. The DMAC operates as follows:

1. Transfer requests are generated simultaneously to channels 1 and 0.
2. Channel 1 has the higher priority, so the channel 1 transfer begins first (channel 0 waits for transfer).
3. When the channel 1 transfer ends, channel 1 becomes the lower-priority channel.
4. The channel 0 transfer begins.
5. When the channel 0 transfer ends, channel 0 becomes the lower-priority channel.
6. A channel 0 transfer is requested.
7. The channel 0 transfer begins.
8. When the channel 0 transfer ends, channel 0 is already the lower-priority channel, so the order remains the same.

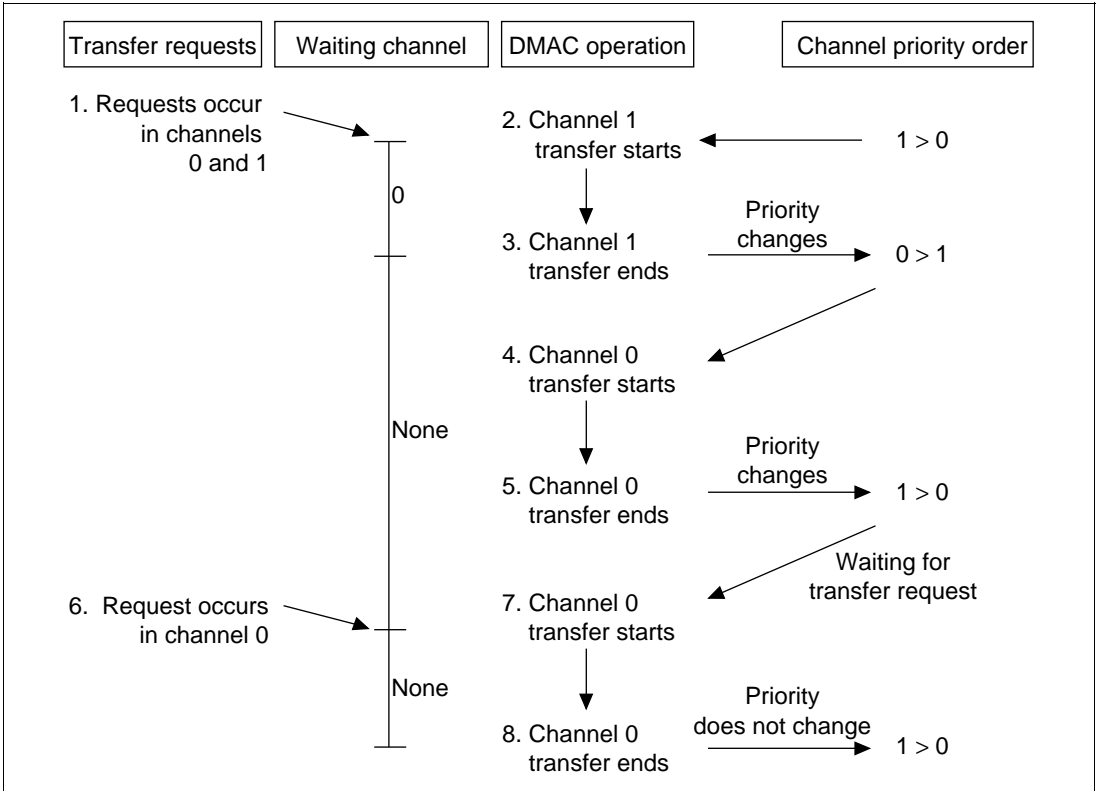

Figure 11.5 Channel Priority in Round-Robin Mode

11.3.4 DMA Transfer Types

It can operate in single address mode or dual address mode, as defined by how many bus cycles the DMAC takes to access the transfer source and transfer destination. The actual transfer operation timing varies with the DMAC bus mode used: cycle-steal mode or burst mode. The DMAC supports all the transfers shown in table 11.7.

Table 11.7 Supported DMA Transfers

Source	Destination				
	External Device with DACK	External Memory	Memory-Mapped External Device	On-Chip Peripheral Module	On-Chip Memory
External device with DACK	Not available	Single	Single	Not available	Not available
External memory	Single	Dual	Dual	Dual*	Dual
Memory-mapped external device	Single	Dual	Dual	Dual*	Dual
On-chip peripheral module	Not available	Dual*	Dual*	Dual*	Dual*
On-chip memory	Not available	Dual	Dual	Dual*	Dual

Single: Single address mode

Dual: Dual address mode

Note: * Access size permitted by peripheral module register used as transfer source or transfer destination (excluding DMAC, BSC, UBC, cache memory, E-DMAC, and EtherC).

Address Modes:

- Single Address Mode

In single address mode, both the transfer source and destination are external; one (selectable) is accessed by a DACK_n signal while the other is accessed by address. In this mode, the DMAC performs the DMA transfer in one bus cycle by simultaneously outputting a transfer request acknowledge DACK_n signal to one external device to access it, while outputting an address to the other end of the transfer. Figure 11.6 shows an example of a transfer between external memory and external device with DACK. That data is written in external memory in the same bus cycle while the external device outputs data to the data bus.

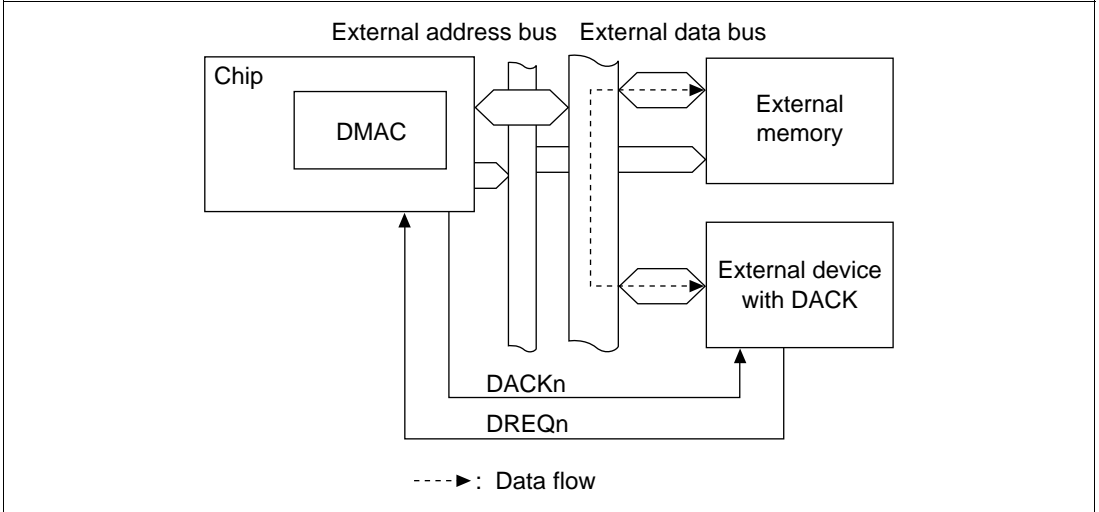
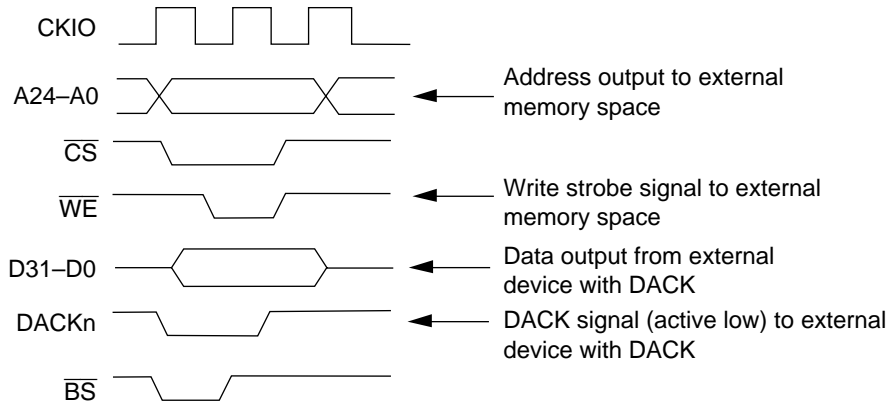
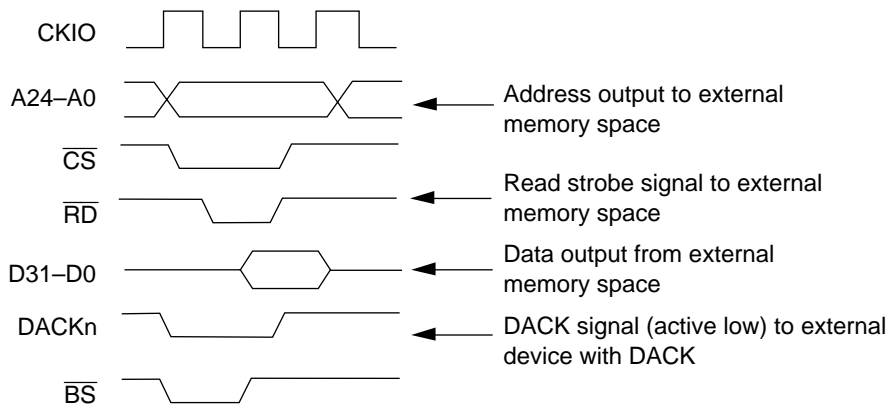

Figure 11.6 Data Flow in Single Address Mode

Two types of transfers are possible in single address mode: 1) transfers between external devices with DACK and memory-mapped external devices; and 2) transfers between external devices with DACK and external memory. For both of them, transfer must be requested by the external request signal (DREQn). For the combination of the specifiable setting to perform data transfer using an external request (DREQn), see table 11.9. Figure 11.7 shows the DMA transfer timing for single address mode.



a. External device with DACK to external memory space



b. External memory space to external device with DACK

Figure 11.7 DMA Transfer Timing in Single Address Mode

- Dual Address Mode

In dual address mode, both the transfer source and destination are accessed (selectable) by address. The source and destination can be located externally or internally. The DMAC accesses the source in the read cycle and the destination in the write cycle, so the transfer is performed in two separate bus cycles. The transfer data is temporarily stored in the DMAC. Figure 11.8 shows an example of a transfer between two external memories in which data is read from one external memory in the read cycle and written to the other external memory in the following write cycle.

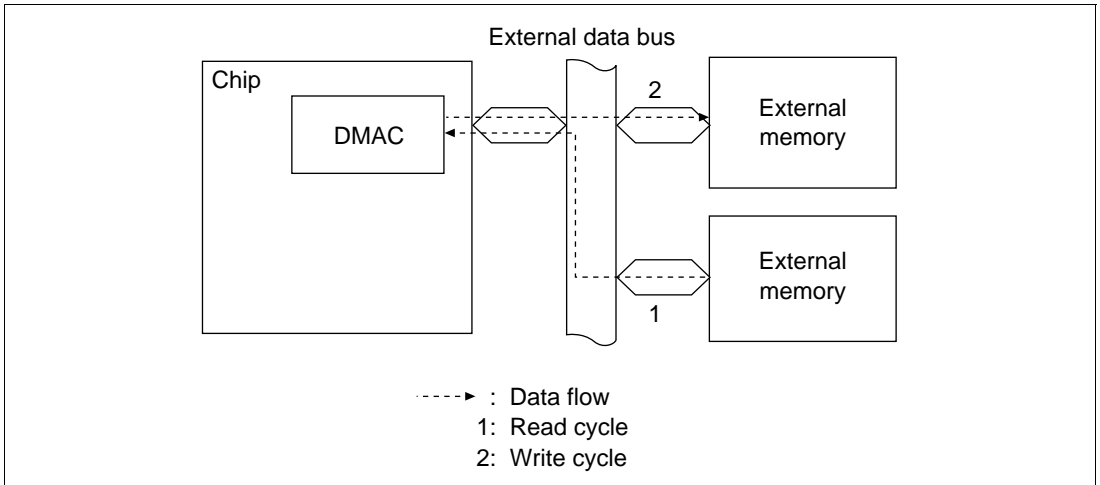

Figure 11.8 Data Flow in Dual Address Mode

In dual address mode transfers, external memory and memory-mapped external devices can be mixed without restriction. Specifically, this enables transfers between the following:

- Transfer between external memory and external memory
- Transfer between external memory and memory-mapped external device
- Transfer between memory-mapped external device and memory-mapped external device
- Transfer between external memory and on-chip peripheral module (excluding DMAC, BSC, UBC, cache, E-DMAC, and EtherC)*
- Transfer between memory-mapped external device and on-chip peripheral module (excluding DMAC, BSC, UBC, cache, E-DMAC, and EtherC)*
- Transfer between on-chip memory and on-chip memory
- Transfer between on-chip memory and memory-mapped external device
- Transfer between on-chip memory and on-chip peripheral module (excluding DMAC, BSC, UBC, cache, E-DMAC, and EtherC)*
- Transfer between on-chip memory and external memory

- Transfer between on-chip peripheral module (excluding DMAC, BSC, UBC, cache, E-DMAC, and EtherC) and on-chip peripheral module (excluding DMAC, BSC, UBC, cache, E-DMAC, and EtherC)*

Note: * Access size permitted by peripheral module register used as transfer source or transfer destination (excluding DMAC, BSC, UBC, cache, E-DMAC, and EtherC).

Transfer requests can be auto-request, external requests, or on-chip peripheral module requests. If the transfer request source is the SCIF, SIOF or SIO, an SCIF, SIOF or SIO register, respectively, must be the transfer destination or transfer source (see table 11.6). For the combination of the specifiable setting to perform data transfer using an external request (DREQn), see table 11.9. Dual address mode outputs DACKn in either the read cycle or write cycle. The acknowledge/transfer mode bit (AM) of the DMA channel control registers 0 and 1 (CHCR0 and 1) specifies whether DACK is output in either the read cycle or the write cycle.

Figure 11.9 shows the DMA transfer timing in dual address mode.

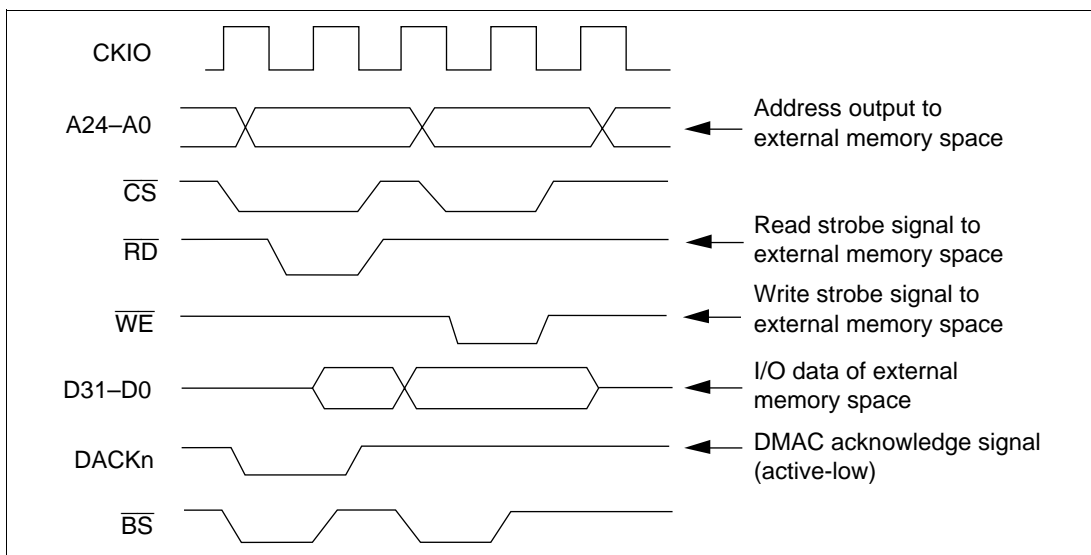

Figure 11.9 DMA Transfer Timing in Dual Address Mode
(External Memory Space → External Memory Space, DACKn Output in Read Cycle)

Bus Modes: There are two bus modes: cycle-steal and burst. Select the mode with the TB bits in CHCR0 and CHCR1.

- Cycle-Steal Mode

In cycle-steal mode, the bus right is given to another bus master each time the DMAC completes one transfer. When another transfer request occurs, the bus right is retrieved from the other bus master and another transfer is performed for one transfer unit. When that transfer ends, the bus right is passed to the other bus master. This is repeated until the transfer end conditions are satisfied. (in the case of 16-byte transfer in dual address mode, the DMAC continues to hold the bus)

Cycle-steal mode can be used with all categories of transfer destination, transfer source, and transfer request source. (with the exception of transfers between on-chip peripheral modules) The CPU may take the bus twice when an acknowledge signal is output during the write cycle or in single address mode. Figure 11.10 shows an example of DMA transfer timing in cycle-steal mode. The transfer conditions for the example in the figure are as shown below.

When the transfer request source is an external request mode with level detection in the cycle-steal mode, set the TS1 and TS0 bits of CHCR0 and CHCR1 to either 00 (byte unit), 01 (word unit), or 01 (longword unit). If the TS1 and TS0 bits of CHCR0 and CHCR1 are set to 11 (16-byte transfer), operation is not guaranteed.

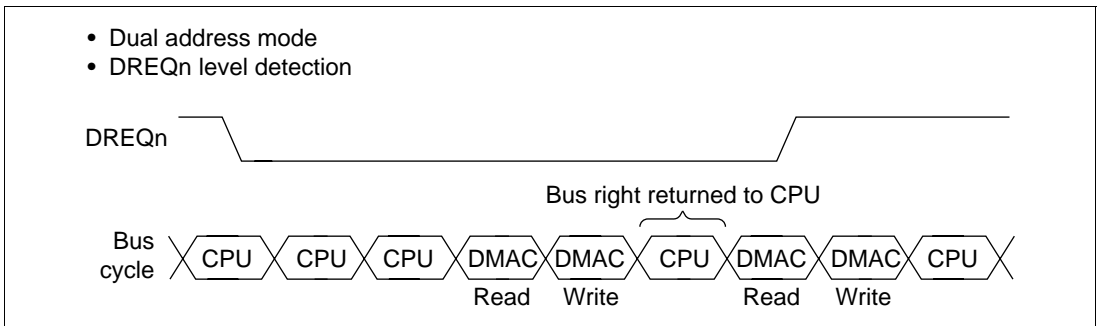

**Figure 11.10 DMA Transfer Timing in Cycle-Steal Mode
(Dual Address Mode, DREQn Low Level Detection)**

- Burst Mode

In burst mode, once the DMAC gets the bus, the transfer continues until the transfer end condition is satisfied. When external request mode is used with level detection of the DREQ pin, however, negating DREQ will pass the bus to the other bus master after completion of the bus cycle of the DMAC that currently has an acknowledged request, even if the transfer end conditions have not been satisfied. When the transfer request source is an on-chip peripheral module, however, cycle-steal mode is always used.

Figure 11.11 shows an example of DMA transfer timing in burst mode. The transfer conditions for the example in the figure are as shown below.

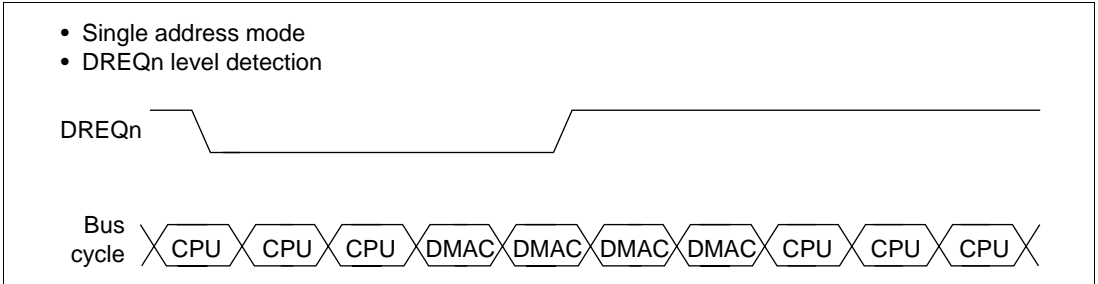

Figure 11.11 DMA Transfer Timing in Burst Mode (Single Address, DREQn Falling-Edge Detection)

Refreshes cannot be performed during a burst transfer, so ensure that the number of transfers satisfies the refresh request period when a memory requiring refreshing is used. When the transfer request source is an external request (DREQn) in burst mode, set the DS bit of CHCR0 and CHCR1 to 1 (edge detection). If the DS bits of CHCR0 and CHCR1 are set to 0 (level detection), operation is not guaranteed.

Relationship of Request Modes and Bus Modes by DMA Transfer Category: Table 11.8 shows the relationship between request modes, bus modes, etc., by DMA transfer category.

Table 11.8 Relationship of Request Modes and Bus Modes by DMA Transfer Category

Address Mode	Transfer Range	Request Mode* ³	Bus Mode* ⁷	Transfer Size (Byte)	
Single	Between external memory and external device with DACK	External	B/C	1/2/4/16* ⁸	
	Between external device with DACK, and memory mapped external device	External	B/C	1/2/4/16* ⁸	
Dual	Between external memories	External	B/C	1/2/4/16* ⁸	
		Automatic	B/C	1/2/4/16	
		Internal peripheral module* ¹	C	1/2/4	
	Between external memory and memory mapped external device	External	B/C	1/2/4/16* ⁸	
		Automatic	B/C	1/2/4/16	
		Internal peripheral module* ¹	C	1/2/4	
	Between memory mapped external devices	External	B/C	1/2/4/16* ⁸	
		Automatic	B/C	1/2/4/16	
		Internal peripheral module* ¹	C	1/2/4	
	Between external memory and internal peripheral module	External	B/C	1/2/4* ⁴	
		Automatic	B/C	1/2/4* ⁴	
		Internal peripheral module* ²	C	1/2/4* ⁴	
	Between memory mapped external device and internal peripheral module	External	B/C	1/2/4* ⁴	
		Automatic	B/C	1/2/4* ⁴	
		Internal peripheral module* ²	C	1/2/4* ⁴	
	Between internal memories	Automatic	B/C	1/2/4/16	
		Between internal memory and memory mapped external device* ⁵	External	B/C	1/2/4/16* ⁸
			Automatic	B/C	1/2/4/16
	Internal peripheral module* ¹	C	1/2/4		

Table 11.8 Relationship of Request Modes and Bus Modes by DMA Transfer Category
(cont)

Address Mode	Transfer Range	Request Mode* ³	Bus Mode* ⁷	Transfer Size (Byte)
Dual	Between internal memory and internal peripheral module	Automatic	B/C	1/2/4* ⁴
		Internal peripheral module* ²	C	1/2/4* ⁴
	Between internal memory and external memory* ⁶	External	B/C	1/2/4/16* ⁸
		Automatic	B/C	1/2/4/16
		Internal peripheral module* ¹	C	1/2/4
	Between internal peripheral modules	Automatic	B/C	1/2/4* ⁴
Internal peripheral module* ²		C	1/2/4* ⁴	

Notes: B: Burst mode

C: Cycle steal mode

*1 For on-chip peripheral module requests, do not specify SCIF, SIOF and SIO as a transfer request source.

*2 When the transfer request source is SCIF, SIOF or SIO, the transfer source or transfer destination must be SCIF, SIOF and SIO, respectively.

*3 When the request mode is set to internal peripheral module request, set the DS bit and the DL bit of CHCR0 and CHCR1 to 1 and 0, respectively (detection at the falling edge of DREQn). In addition, the bus mode can only be set to cycle-steal mode.

*4 Specify the access size that is allowed by the internal peripheral-module registers, which are a transfer source or a transfer destination.

*5 When transferring data from internal memory to a memory mapped external device, set DACKn to write-time output. When transferring from a memory mapped external device to internal memory, set DACKn to read-time output.

*6 When transferring data from internal memory to external memory, set DACKn to write-time output. When transferring from external memory to internal memory, set DACKn to read-time output.

*7 When B (burst mode) is set in the external request mode, set the DS bits of CHCR0 and CHCR1 to 1 (edge detection). If they are set to 0 (level detection), operation cannot be guaranteed.

*8 Transfer in units of 16 bytes is enabled only when edge detection has been specified. If transfer is attempted in units of 16 bytes when level detection has been specified, operation cannot be guaranteed.

Table 11.9 shows the combinations of request mode, bus mode, and address mode that can be specified in the external request mode.

Table 11.9 Combinations of Request Mode, Bus Mode, and Address Mode Specifiable in the External Request Mode

Request Mode			Dual Address Mode		Single Address Mode	
			Burst Mode	Cycle-Steal Mode	Burst Mode	Cycle-Steal Mode
External request	Level detection* ¹	Byte	—	O	—	O
		Word	—	O	—	O
		Longword	—	O	—	O
		16-byte unit	—	—	—	—
Edge detection* ²	Edge detection* ²	Byte	O	O	O	O
		Word	O	O	O	O
		Longword	O	O	O	O
		16-byte unit	O	O	O	O

Notes: O: Can be set

—: Cannot be set

*1 The same for high-level and low-level detection.

*2 The same for rising-edge detection and falling-edge detection.

Bus Mode and Channel Priority: When a given channel (1) is transferring in burst mode and there is a transfer request to a channel (0) with a higher priority, the transfer of the channel with higher priority (0) will begin immediately. When channel 0 is also operating in the burst mode, the channel 1 transfer will continue as soon as the channel 0 transfer has completely finished. When channel 0 is in cycle-steal mode, channel 1 will begin operating again after channel 0 completes the transfer of one transfer unit, but the bus will then switch between the two in the order channel 1, channel 0, channel 1, channel 0. Since channel 1 is in burst mode, it will not give the bus to the CPU. This example is illustrated in Figure 11.12.

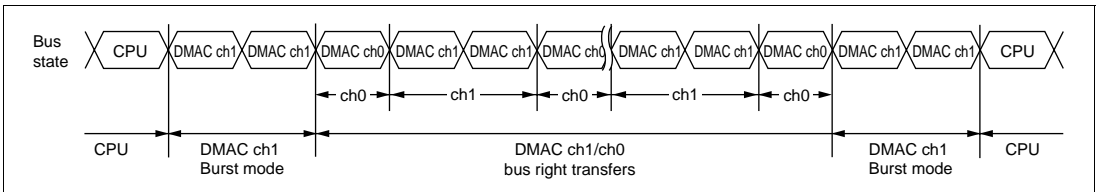

Figure 11.12 Bus Status when Multiple Channels are Operating (when priority order is ch0 > ch1, ch1 is set to burst mode, and ch0 to cycle-steal mode)

11.3.5 Number of Bus Cycles

The number of states in the bus cycle when the DMAC is the bus master is controlled by the bus state controller (BSC) just as it is when the CPU is the bus master. For details, see section 7, Bus State Controller (BSC).

11.3.6 DMA Transfer Request Acknowledge Signal Output Timing

DMA transfer request acknowledge signal DACKn is output synchronous to the DMA address output specified by the channel control register AM bit of the address bus. Normally, the acknowledge signal becomes valid when DMA address output begins, and becomes invalid 0.5 cycles before the address output ends. (See figure 11.13.) The output timing of the acknowledge signal varies with the settings of the connected memory space. The output timing of acknowledge signals in the memory spaces is shown in figure 11.13.

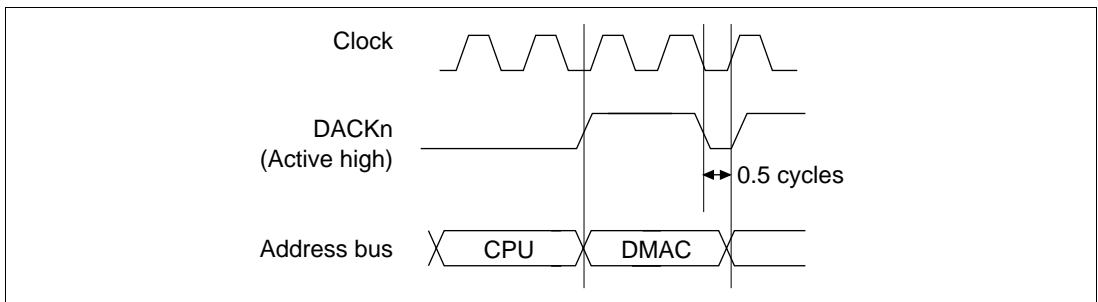

Figure 11.13 Example of DACKn Output Timing

Acknowledge Signal Output when External Memory Is Set as Ordinary Memory Space:

The timing at which the acknowledge signal is output is the same in the DMA read and write cycles specified by the AM bit (figures 11.14 and 11.15). When DMA address output begins, the acknowledge signal becomes valid; 0.5 cycles before address output ends, it becomes invalid. If a wait is inserted in this period and address output is extended, the acknowledge signal is also extended.

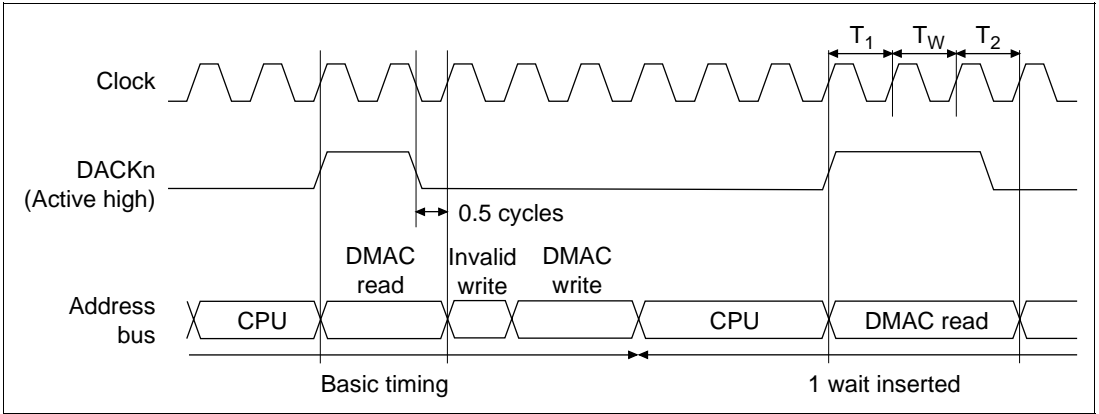

Figure 11.14 DACKn Output in Ordinary Space Accesses (AM = 0)

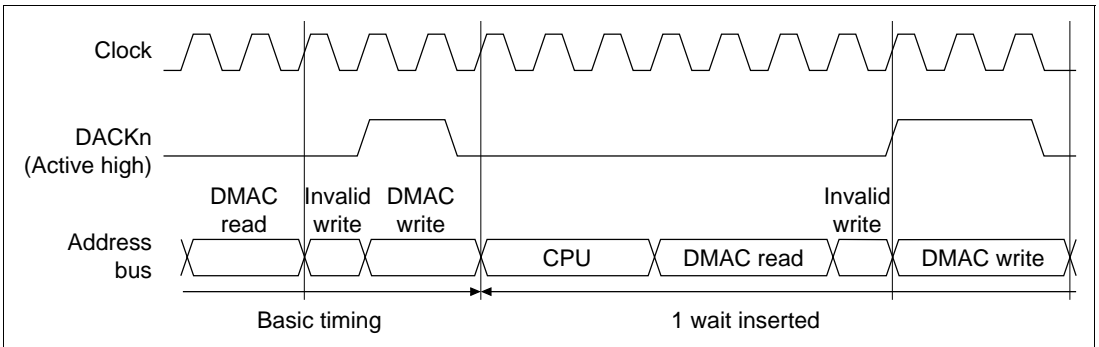
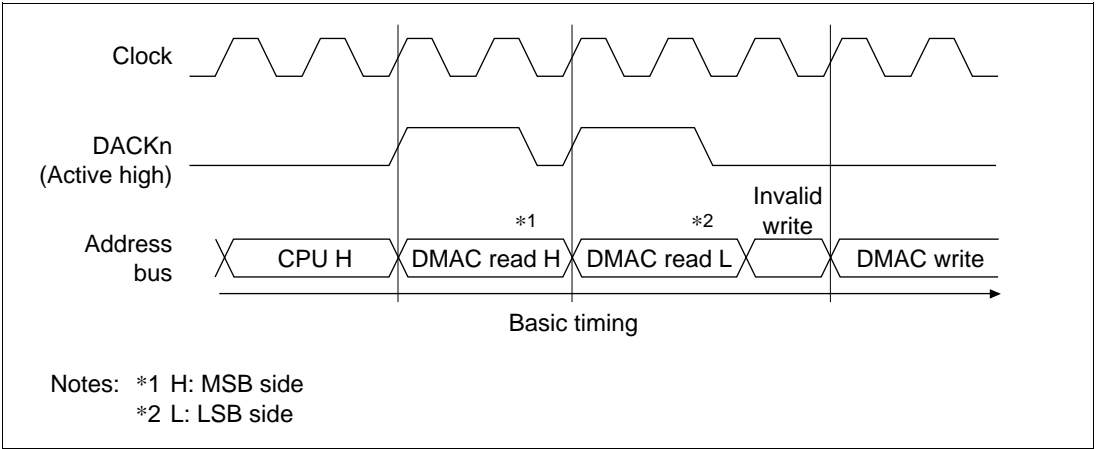
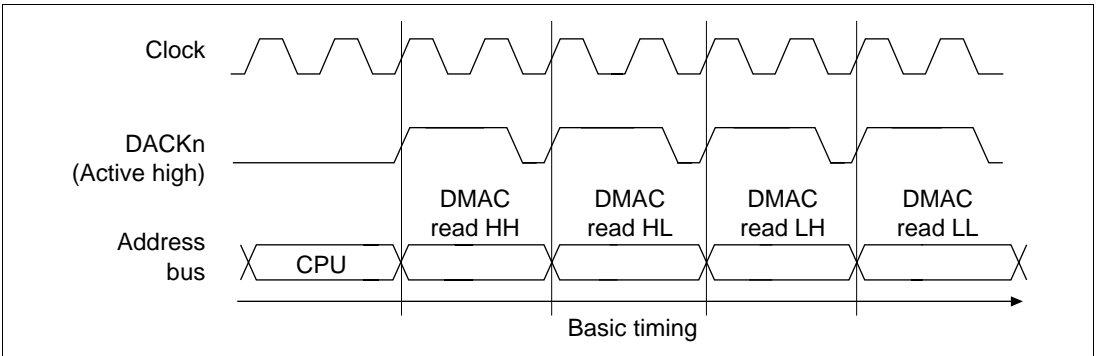

Figure 11.15 DACKn Output in Ordinary Space Accesses (AM = 1)

In a longword access of a 16-bit external device (figure 11.16) or an 8-bit external device (figure 11.17), or a word access of an 8-bit external device (figure 11.18), the lower and upper addresses are output 2 and 4 times in each DMAC access in order to align the data. For all of these addresses, the acknowledge signal becomes valid simultaneous with the start of output and the signal becomes invalid 0.5 cycles before the address output ends. When multiple addresses are output in a single access to align data for synchronous DRAM, DRAM, or burst ROM, an acknowledge signal is output to those addresses as well.



**Figure 11.16 DACKn Output in Ordinary Space Accesses
 (AM = 0, Longword Access to 16-Bit External Device)**



**Figure 11.17 DACKn Output in Ordinary Space Accesses
 (AM = 0, Longword Access to 8-Bit External Device)**

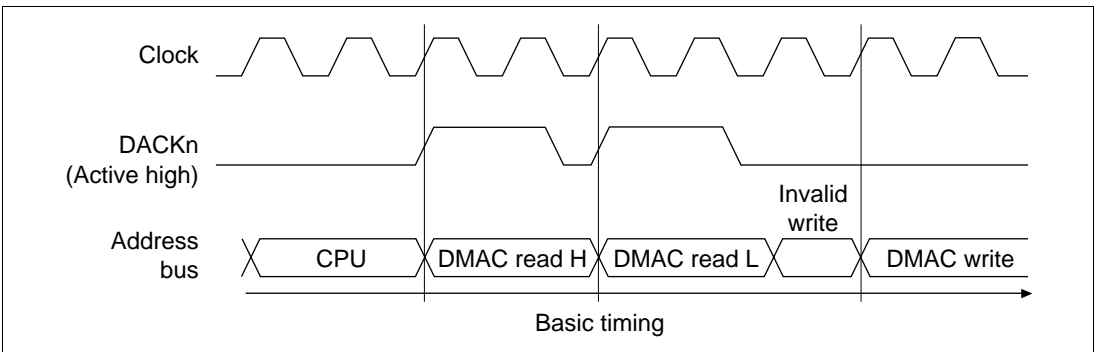

**Figure 11.18 DACKn Output in Ordinary Space Accesses
 (AM = 0, Word Access to 8-Bit External Device)**

Acknowledge Signal Output when External Memory Is Set as Synchronous DRAM: When external memory is set as synchronous DRAM, DACKn output becomes valid simultaneously with the start of the DMA address, and becomes invalid when the address output ends.

When external memory is set as synchronous DRAM auto-precharge and $AM = 0$, the acknowledge signal is output across the row address, read command, wait and read address of the DMAC read (figure 11.19). Since the synchronous DRAM read has only burst mode, during a single read an invalid address is output; the acknowledge signal, however, is output on the same timing (figure 11.20). At this time, the acknowledge signal is extended until the write address is output after the invalid read. A synchronous DRAM burst read is performed in the case of 16-byte transfer. As 16-byte transfer is enabled only in auto-request mode and in external request mode with edge detection, when using on-chip peripheral module requests or external request mode with level detection, byte, word, or longword should be set as the transfer unit. Operation is not guaranteed if a 16-byte unit is set when using on-chip peripheral module requests or external request mode with level detection. When $AM = 1$, the acknowledge signal is output across the row address and column address of the DMAC write (figure 11.21).

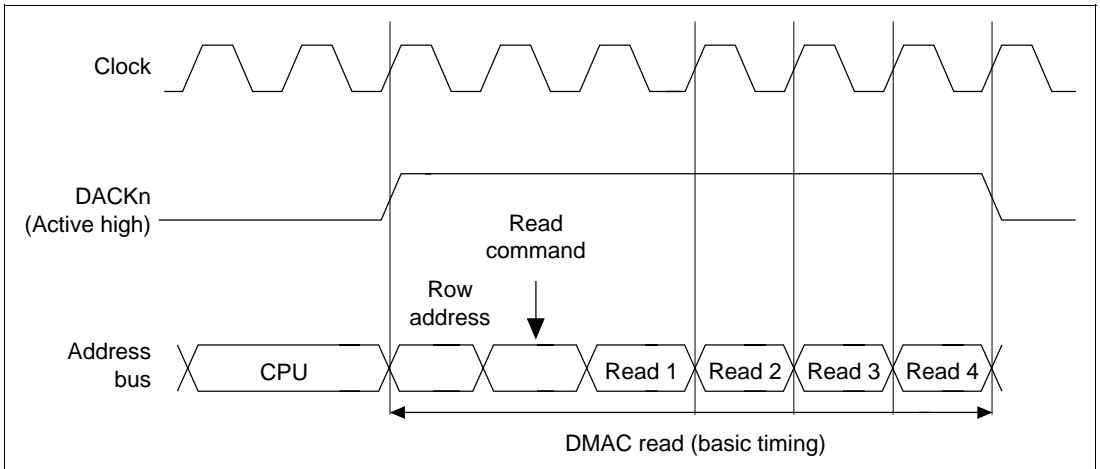

Figure 11.19 DACKn Output in Synchronous DRAM Burst Read (Auto-Precharge, $AM = 0$)

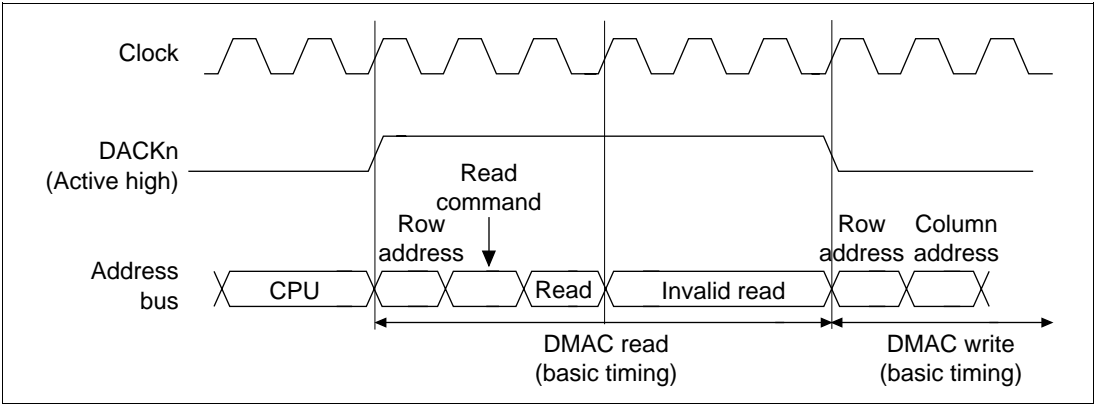

Figure 11.20 DACKn Output in Synchronous DRAM Single Read (Auto-Precharge, AM = 0)

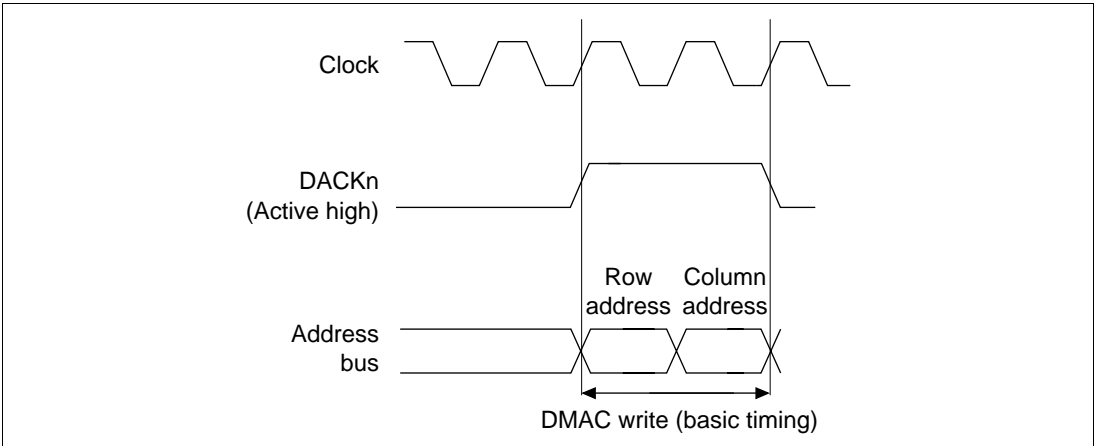
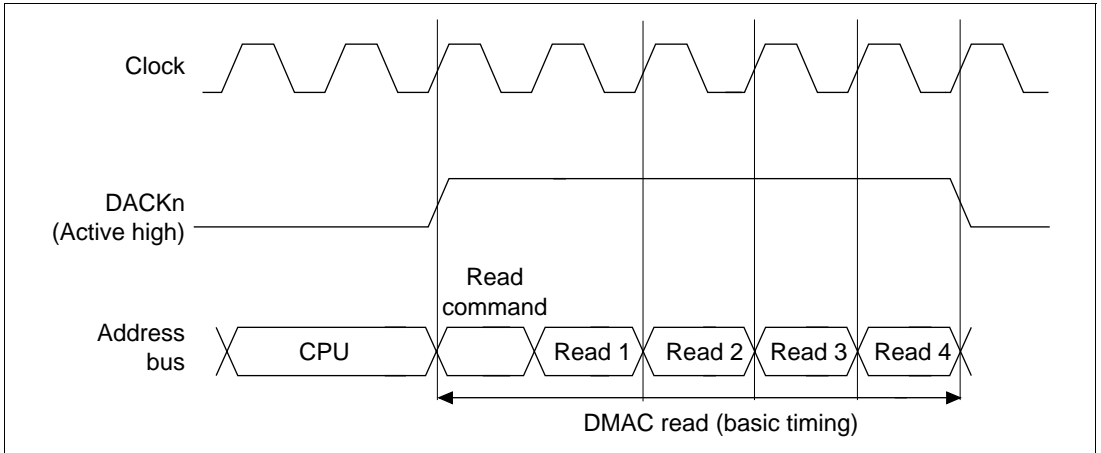
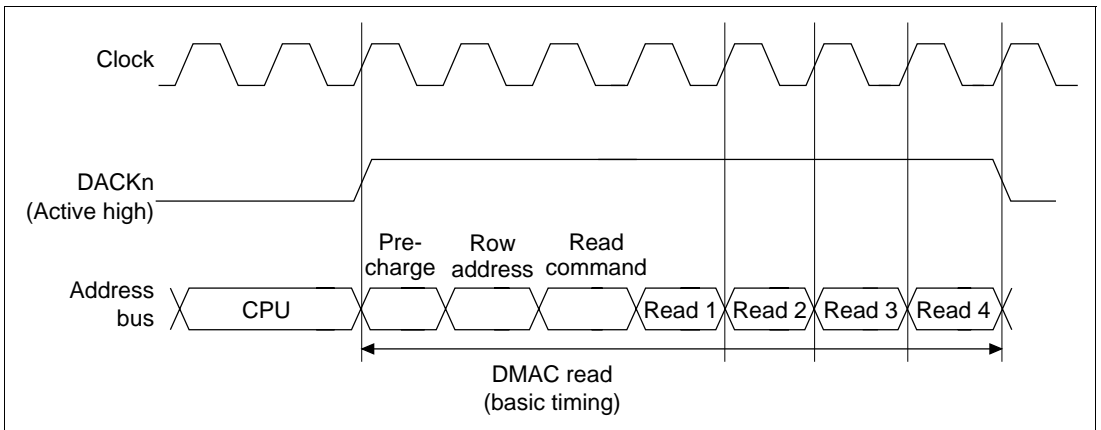

Figure 11.21 DACKn Output in Synchronous DRAM Write (Auto-Precharge, AM = 1)

When external memory is set as bank active synchronous DRAM, during a burst read the acknowledge signal is output across the read command, wait and read address when the row address is the same as the previous address output (figure 11.22). When the row address is different from the previous address, the acknowledge signal is output across the precharge, row address, read command, wait and read address (figure 11.23).

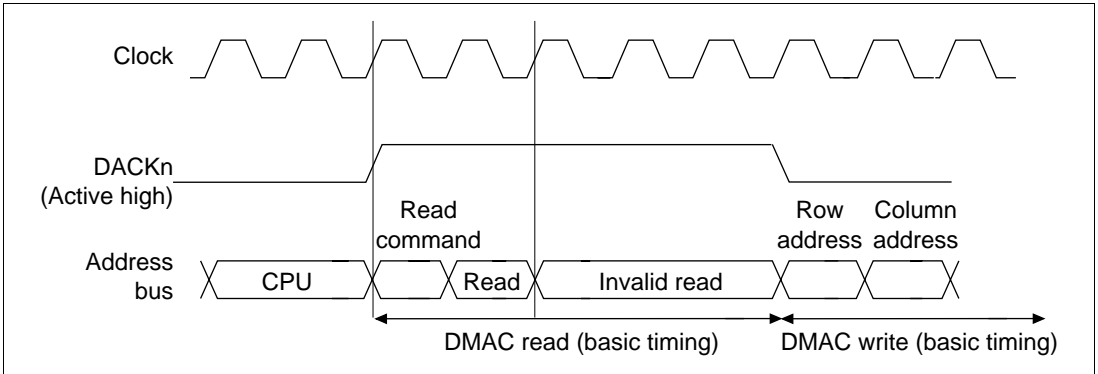

**Figure 11.22 DACKn Output in Synchronous DRAM Burst Read
(Bank Active, Same Row Address, AM = 0)**

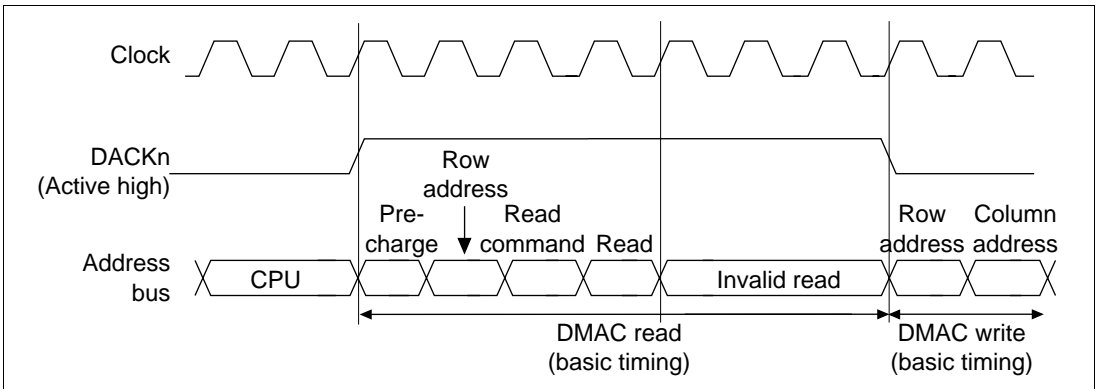

**Figure 11.23 DACKn Output in Synchronous DRAM Burst Read
(Bank Active, Different Row Address, AM = 0)**

When external memory is set as bank active synchronous DRAM, during a single read the acknowledge signal is output across the read command, wait and read address when the row address is the same as the previous address output (figure 11.24). When the row address is different from the previous address, the acknowledge signal is output across the precharge, row address, read command, wait and read address (figure 11.25). Since the synchronous DRAM read has only burst mode, during a single read an invalid address is output; the acknowledge signal is output on the same timing. At this time, the acknowledge signal is extended until the write address is output after the invalid read.

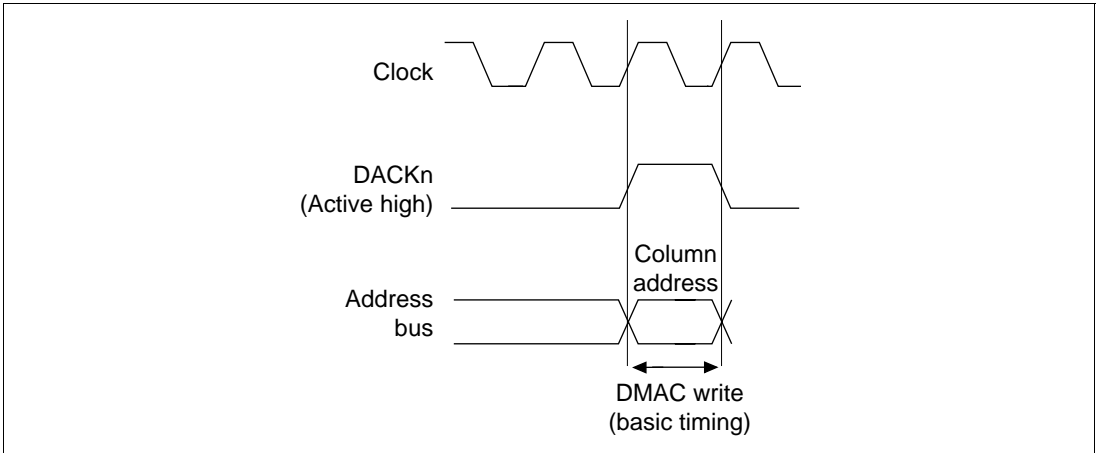

**Figure 11.24 DACKn Output in Synchronous DRAM Single Read
(Bank Active, Same Row Address, AM = 0)**

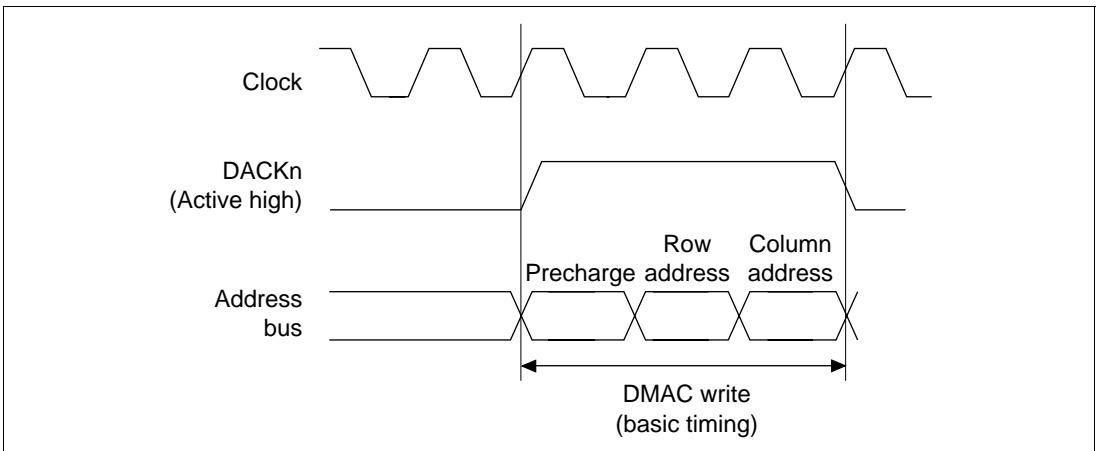

**Figure 11.25 DACKn Output in Synchronous DRAM Single Read
(Bank Active, Different Row Address, AM = 0)**

When external memory is set as bank active synchronous DRAM, during a write the acknowledge signal is output across the wait and column address when the row address is the same as the previous address output (figure 11.26). When the row address is different from the previous address, the acknowledge signal is output across the precharge, row address, wait and column address (figure 11.27).



**Figure 11.26 DACKn Output in Synchronous DRAM Write
(Bank Active, Same Row Address, AM = 1)**



**Figure 11.27 DACKn Output in Synchronous DRAM Write
(Bank Active, Different Row Address, AM = 1)**

- Synchronous DRAM one-cycle write

When a one-cycle write is performed to synchronous DRAM, the DACKn signal is synchronized with the rising edge of the clock. A request by the request signal is accepted while the clock is high during DACKn output.

Transfer Width	Byte/Word/Longword Transfer* ¹	DREQn Detection Method	Level Detection
Transfer bus mode	Cycle-steal mode* ²	DACKn output timing	Write DACK
Transfer address mode	Single mode	Bus cycle	Basic bus cycle

Notes: *1 Do not set a 16-byte unit; operation is not guaranteed if this setting is made.

*2 Cycle-steal mode must be set when DREQ is level-detected.

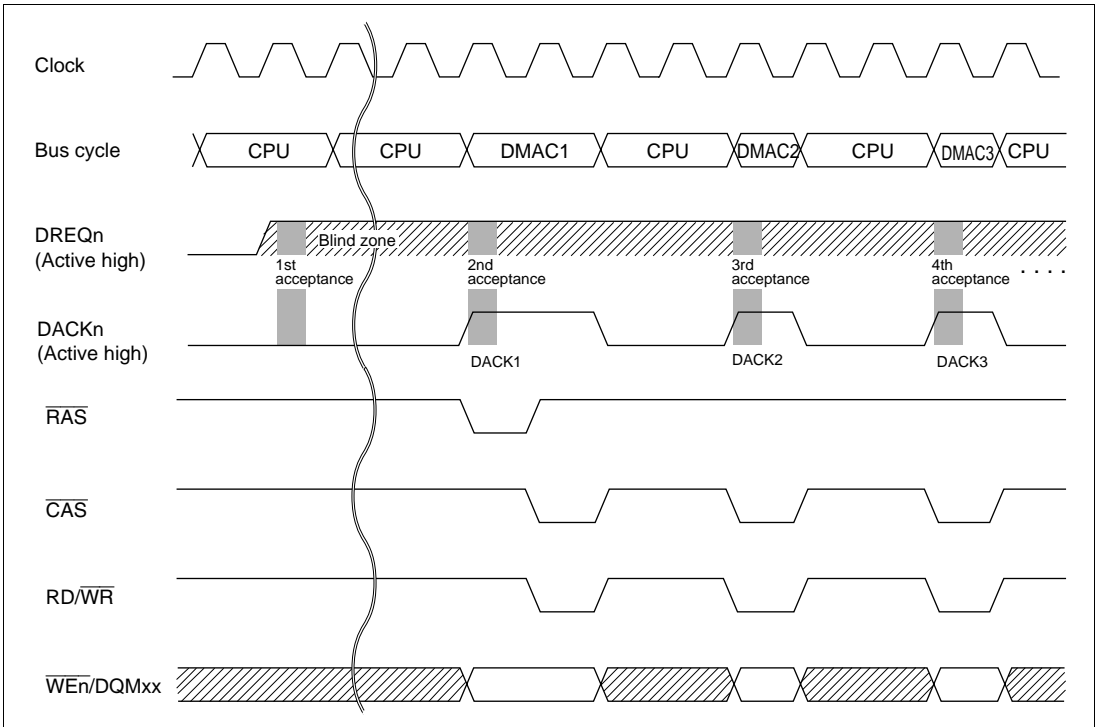

Figure 11.28 (a) Synchronous DRAM One-Cycle Write Timing

Transfer Width	Byte/Word/Longword Transfer	DREQn Detection Method	Edge Detection*
Transfer bus mode	Burst mode	DACKn output timing	Write DACK
Transfer address mode	Single mode	Bus cycle	Basic bus cycle

Note: * Edge detection must be set when burst mode is selected as the transfer bus mode.

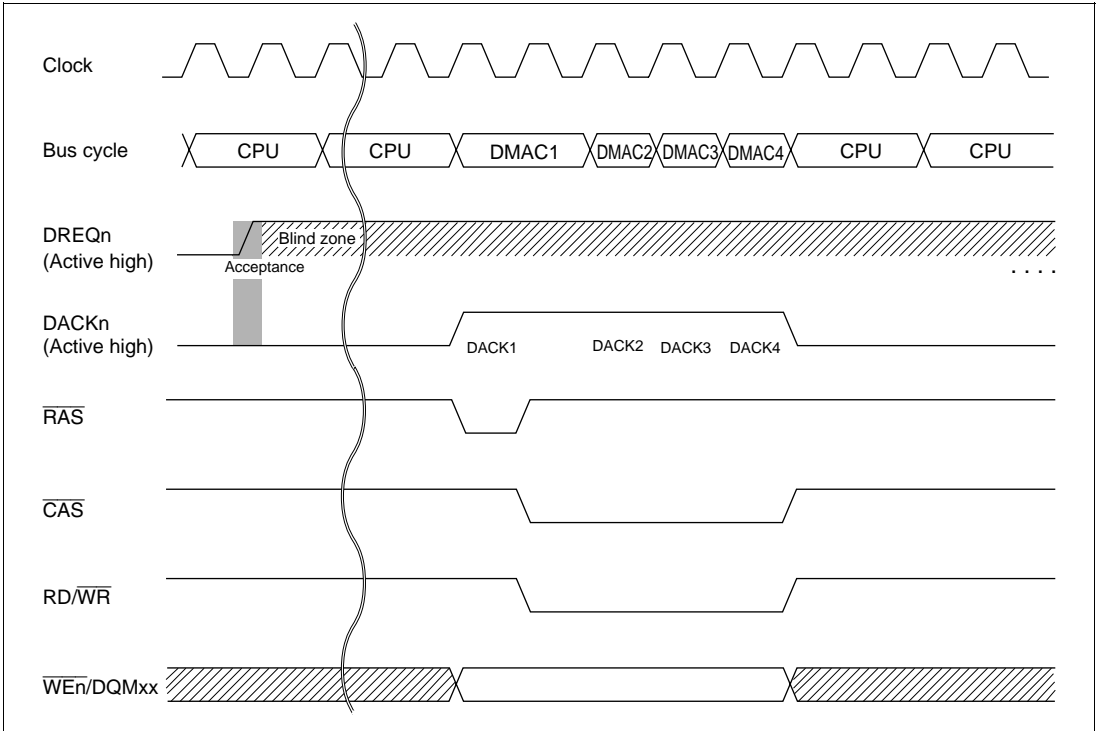

Figure 11.28 (b) Synchronous DRAM One-Cycle Write Timing

Acknowledge Signal Output when External Memory Is Set as DRAM: When external memory is set as DRAM and a row address is output during a read or write, the acknowledge signal is output across the row address and column address (figures 11.29–11.31).

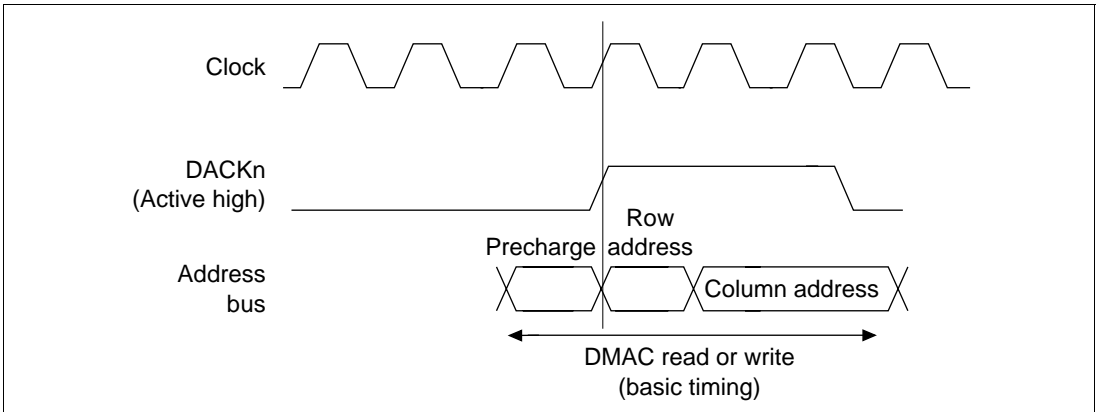
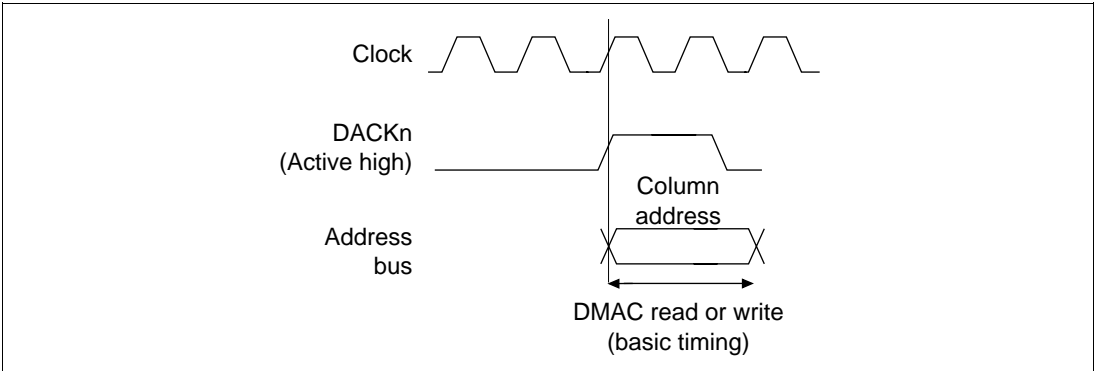
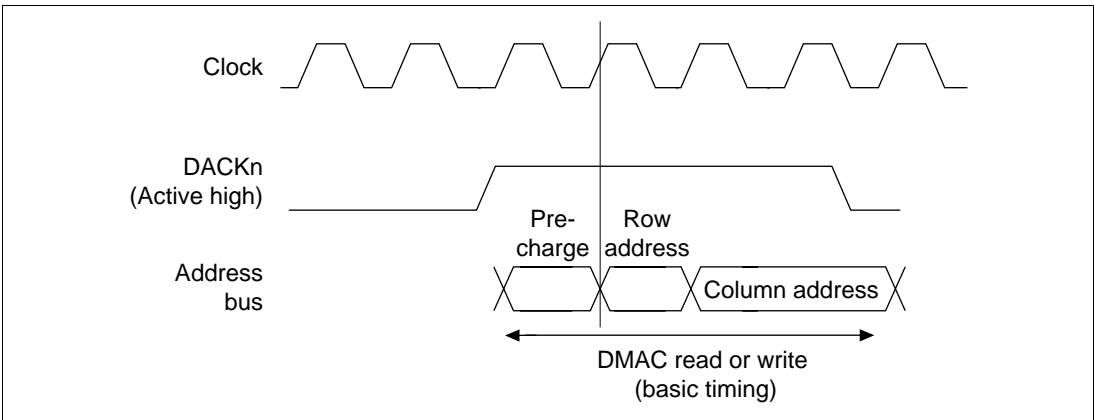

Figure 11.29 DACKn Output in Normal DRAM Accesses (AM = 0 or 1)



**Figure 11.30 DACKn Output in DRAM Burst Accesses
(Same Row Address, AM = 0 or 1)**



**Figure 11.31 DACKn Output in DRAM Burst Accesses
(Different Row Address, AM = 0 or 1)**

Acknowledge Signal Output When External Memory Is Set as Burst ROM: When external memory is set as burst ROM, the acknowledge signal is output synchronous to the DMA address (no dual writes allowed) (figure 11.32).

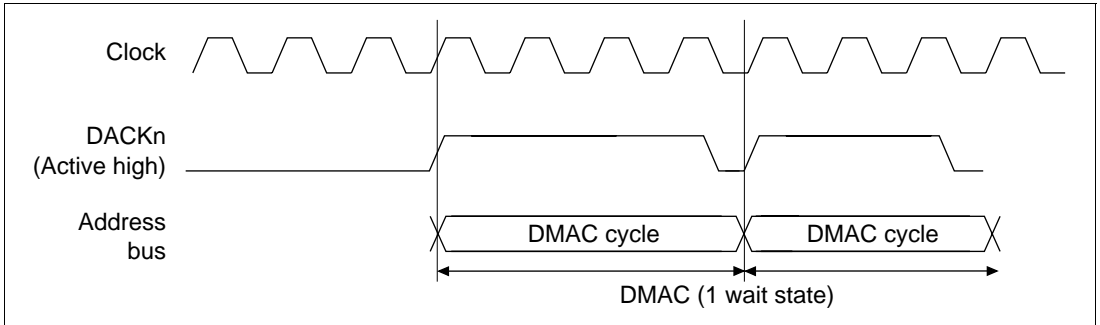

Figure 11.32 DACKn Output in Nibble Accesses of Burst ROM

11.3.7 DREQn Pin Input Detection Timing

In external request mode, DREQn pin signals are usually detected at the falling edge of the clock pulse (CKIO). When a request is detected, a DMAC bus cycle is produced four cycles later at the earliest and a DMA transfer performed. After the request is detected, the timing of the next input detection varies with the bus mode, address mode, DREQn input detection, and the memory connected.

DREQn Pin Input Detection Timing in Cycle-Steal Mode: In cycle-steal mode, once a request is detected from the DREQn pin, the request signal is not detected until DACKn signal output in the next external bus cycle. In cycle-steal mode, request detection is performed from DACKn signal output until a request is detected.

Once a request has been accepted, it cannot be canceled midway.

The timing from the detection of a request until the next time requests are detectable is shown below.

- Cycle-Steal Mode Edge Detection

When transfer control is performed using edge detection, perform DREQn/DACKn handshaking as shown in figure 11.33, and perform DREQn input control so that there is a one-to-one relationship between DREQn and DACKn. Operation is not guaranteed if DREQn is input before the corresponding DACKn is output.

If the DACKn signal is output a number of times, the first DACKn signal for the input DREQn signal indicates the request acceptance start timing, and subsequently each clock edge is sampled.

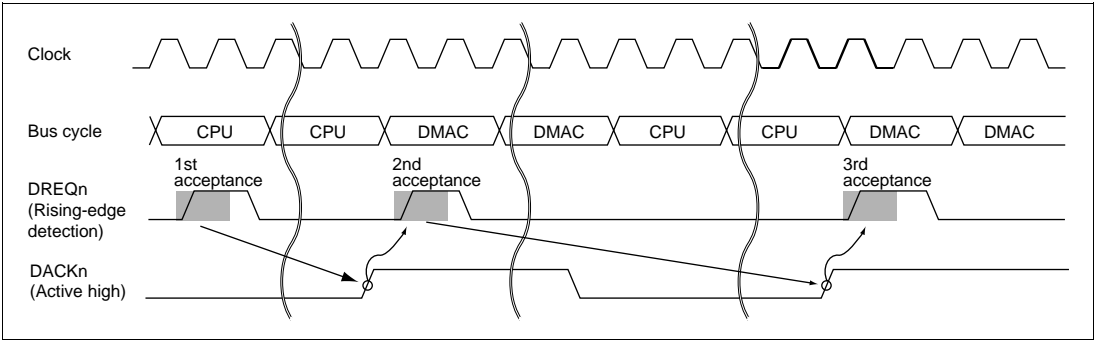

Figure 11.33 DREQn/DACKn Handshaking

Transfer Width	Byte/Word/Longword	DREQn Detection Method	Edge Detection
Transfer bus mode	Cycle-steal mode	DACKn output timing	Read DACK/write DACK
Transfer address mode	Dual/single mode	Bus cycle	Basic bus cycle

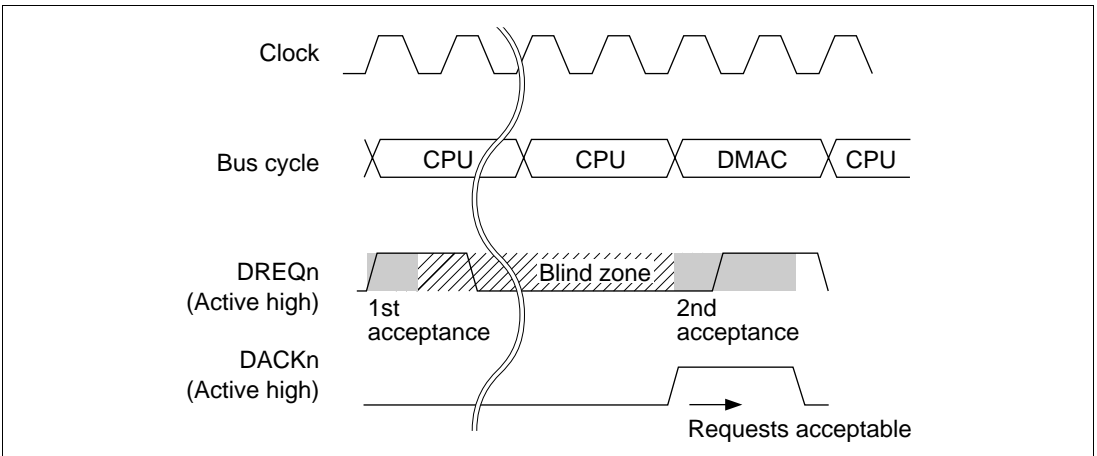

Figure 11.34 DREQn Pin Input Detection Timing in Cycle-Steal Mode with Edge Detection

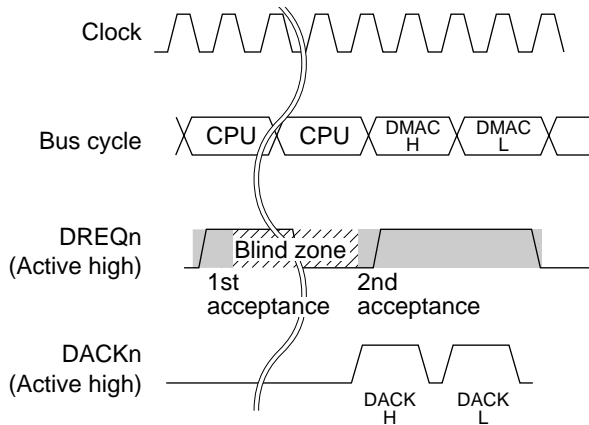

Figure 11.35 When a 16-Bit External Device is Connected (Edge Detection)

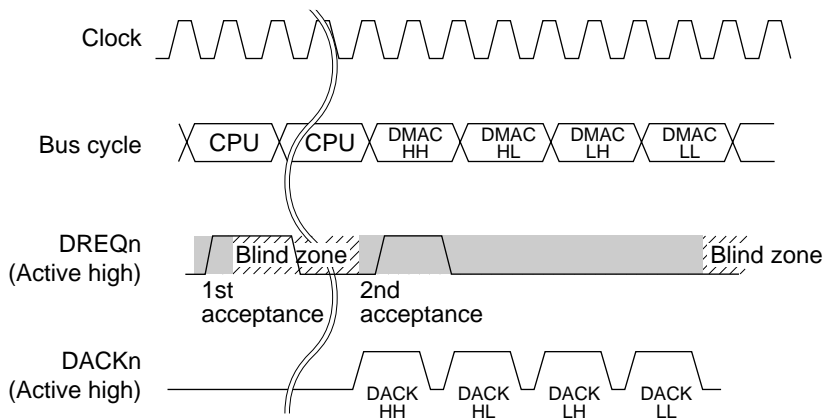

Figure 11.36 When an 8-Bit External Device is Connected (Edge Detection)

- Cycle-Steal Mode Edge Detection—16-Bit Transfer

With 16-byte transfer, the first request signal is the first transfer request, and the second transfer request is accepted when the next request signal is accepted. The third and fourth requests are accepted in the same way.

Transfer Width	16-Byte Transfer	DREQn Detection Method	Edge Detection
Transfer bus mode	Cycle-steal mode	DACKn output timing	Read DACK/write DACK
Transfer address mode	Dual/single mode	Bus cycle	Basic bus cycle

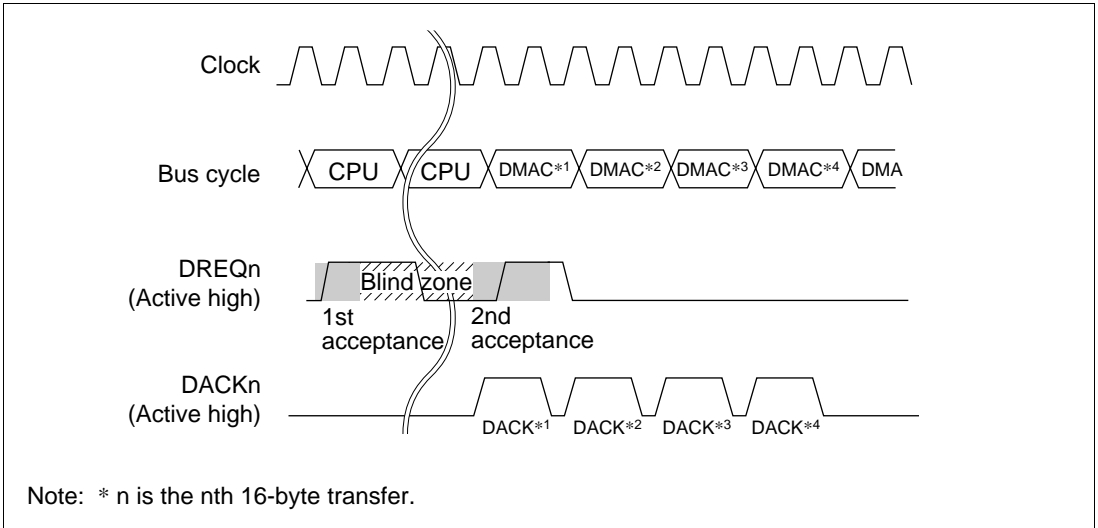

Figure 11.37 DREQn Pin Input Detection Timing in Cycle-Steal Mode with Edge Detection (16-Byte Transfer Setting)

- Cycle-Steal Mode Level Detection

In level detection mode, too, a request cannot be canceled once accepted.

Transfer Width	Byte/Word/Longword*	DREQn Detection Method	Level Detection
Transfer bus mode	Cycle-steal mode	DACKn output timing	Read DACK/write DACK
Transfer address mode	Dual/single mode	Bus cycle	Basic bus cycle

Note: * Do not set a 16-byte unit; operation is not guaranteed if this setting is made.

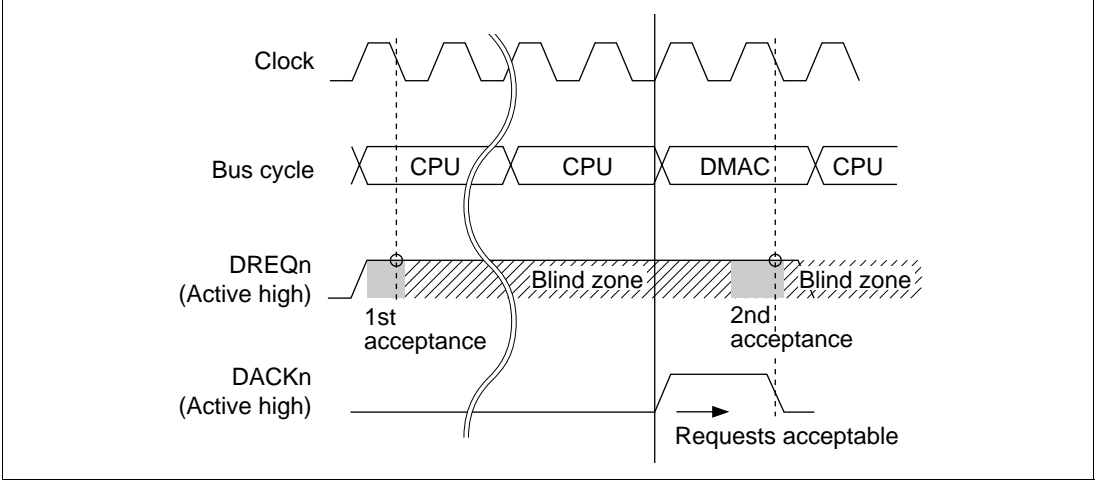

Figure 11.38 DREQn Pin Input Detection Timing in Cycle-Steal Mode with Level Detection (Byte/Word/Longword Setting)

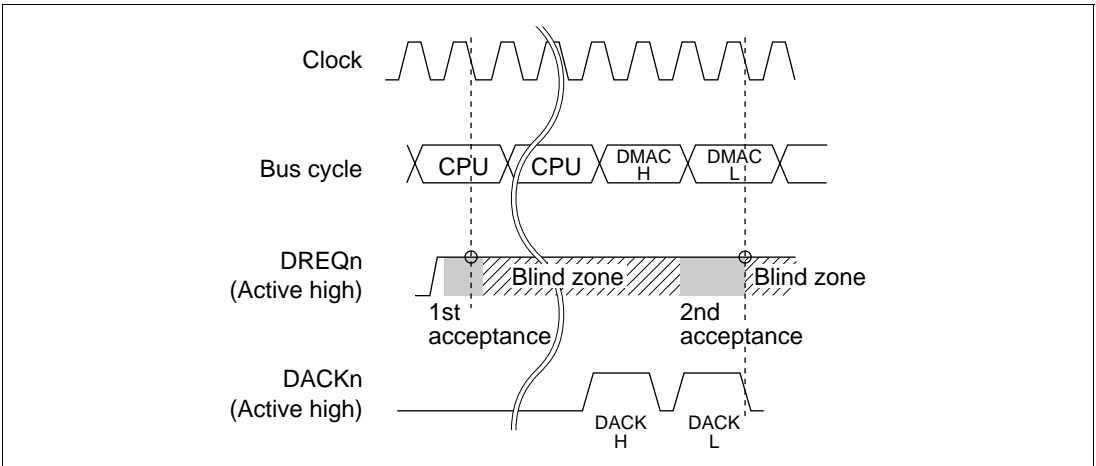

Figure 11.39 When a 16-Bit External Device is Connected (Level Detection)

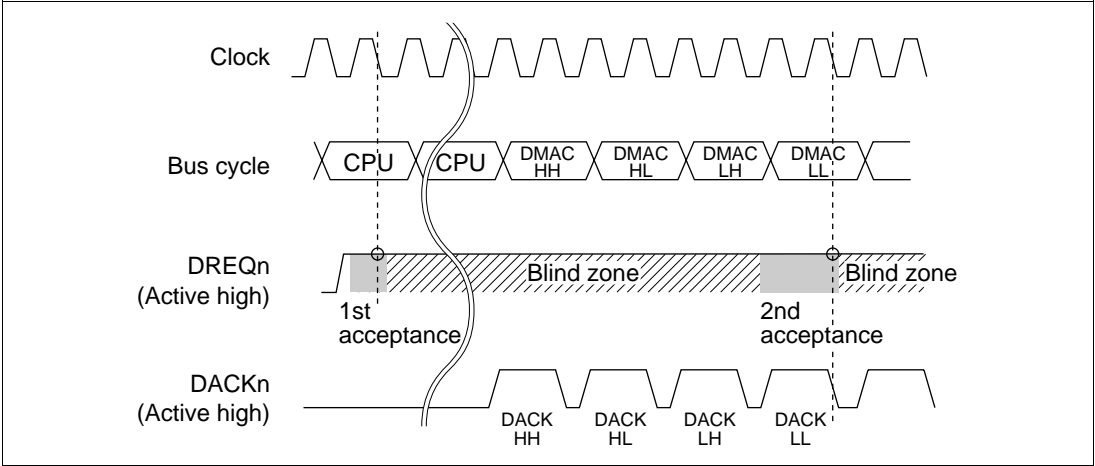

Figure 11.40 When an 8-Bit External Device is Connected (Level Detection)

DREQn Pin Input Detection Timing in Burst Mode: In burst mode, only edge detection is valid for DREQn input. Operation is not guaranteed if level detection is set.

With edge detection of DREQn input, once a request is detected, DMA transfer continues until the transfer end condition is satisfied, regardless of the state of the DREQn pin. Request detection is not performed during this time. When the transfer start conditions are fulfilled after the end of transfer, request detection is performed again every cycle.

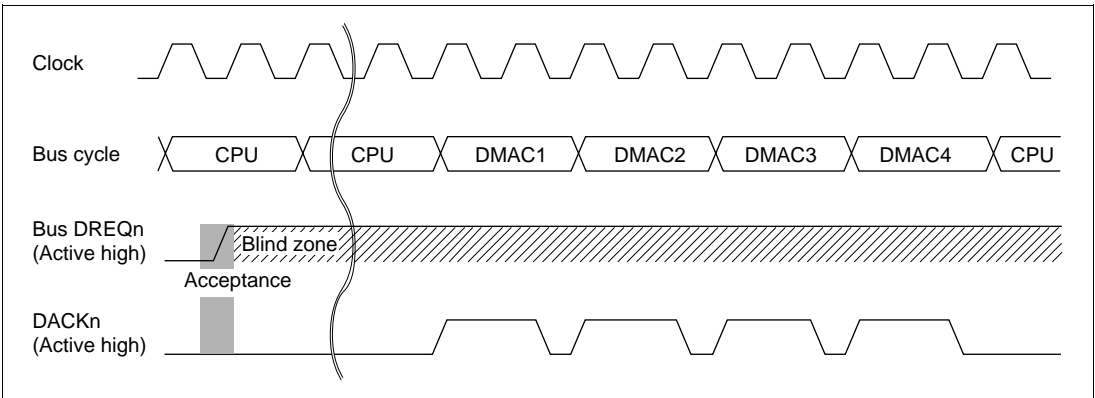

Figure 11.41 DREQn Pin Input Detection Timing in Burst Mode with Edge Detection

11.3.8 DMA Transfer End

The DMA transfer ending conditions vary when channels end individually and when both channels end together.

Conditions for Channels Ending Individually: When either of the following conditions is met, the transfer will end in the relevant channel only:

The DMA transfer count register (TCR) value becomes 0.

The DMA enable bit (DE) of the DMA channel control register (CHCR) is cleared to 0.

- Transfer end when $TCR = 0$

When the TCR value becomes 0, the DMA transfer for that channel ends and the transfer-end flag bit (TE) is set in CHCR. If the IE (interrupt enable) bit has already been set, a DMAC interrupt (DEI) request is sent to the CPU. For 16-byte transfer, set the number of transfers $\times 4$. Operation is not guaranteed if an incorrect value is set.

A 16-byte transfer is valid only in auto-request mode or in external request mode with edge detection. When using an external request with level detection or on-chip peripheral module request, do not specify a 16-byte transfer.

- Transfer end when $DE = 0$ in CHCR

When the DMA enable bit (DE) in CHCR is cleared, DMA transfers in the affected channel are halted. The TE bit is not set when this happens.

Conditions for Both Channels Ending Simultaneously: Transfers on both channels end when either of the following conditions is met:

The NMIF (NMI flag) bit or AE (address error flag) bit in DMAOR is set to 1.

The DMA master enable (DME) bit is cleared to 0 in DMAOR.

- Transfer end when $NMIF = 1$ or $AE = 1$ in DMAOR

When an NMI interrupt or DMAC address error occurs and the NMIF or AE bit is set to 1 in DMAOR, all channels stop their transfers. The DMA source address register (SAR), destination address register (DAR), and transfer count register (TCR) are all updated by the transfer immediately preceding the halt. When this transfer is the final transfer, $TE = 1$ and the transfer ends. To resume transfer after NMI interrupt exception handling or address error exception handling, clear the appropriate flag bit. When the DE bit is then set to 1, the transfer on that channel will restart. To avoid this, keep its DE bit at 0. In dual address mode, DMA transfer will be halted after the completion of the following write cycle even when the address error occurs in the initial read cycle. SAR, DAR and TCR are updated by the final transfer.

- Transfer end when $DME = 0$ in DMAOR

Clearing the DME bit in DMAOR forcibly aborts the transfers on both channels at the end of the current bus cycle. When the transfer is the final transfer, $TE = 1$ and the transfer ends.

Summary of \overline{BH} Timing: Figure 11.43 is a summary of the \overline{BH} output timing.

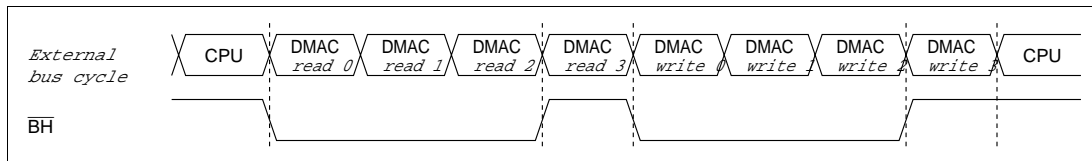

Figure 11.43 Summary of \overline{BH} Output Timing

11.4 Usage Examples

11.4.1 Example of DMA Data Transfer Between SCIF and External Memory

In this example data received by the serial communication interface with FIFO (SCIF) is sent to external memory using DMAC channel 1. Table 11.10 lists the transfer conditions and register setting values.

Table 11.10 Transfer Conditions and Register Setting Values for Data Transfer Between On-chip SCIF and External Memory

Transfer Condition	Register	Setting Value
Transfer source: SCFRDR1 in SCIF	SAR1	H'FFFFFFCC
Transfer destination: External memory (word space)	DAR1	Transfer destination address
Number of transfers: 64	TCR1	H'0040
Transfer destination address: Increment	CHCR1	H'4045
Transfer source address: Fixed		
Bus mode: Cycle-steal		
Transfer unit: Byte		
DEI interrupt request at end of transfer DE = 1		
Channel priority: Fixed (0 > 1) DME = 1	DMAOR	H'0001
Transfer request source (transfer request signal): SCIF (RXI)	DRCR1	H'05

Note: Make sure the SCIF settings have interrupts enabled and the appropriate CPU interrupt level.

11.5 Usage Notes

1. DMA request/response selection control registers 0 and 1 (DRCR0 and DRCR1) should be accessed in bytes. All other registers should be accessed in longword units.
2. Before rewriting the registers in the DMAC (CHCR0, CHCR1, DRCR0, DRCR1), first clear the DE bit to 0 in the CHCR register for the specified channel, or clear the DME bit in DMAOR to 0.
3. When the DMAC is not operating, the NMIF bit in DMAOR is set even when an NMI interrupt is input.
4. The DMAC cannot access the cache memory.
5. Before changing the frequency or changing to standby mode, set the DME bit of DMAOR to 0 and stop operation of the DMAC.
6. Do not use the DMAC, BSC, UBC, E-DMAC, and EtherC for on-chip peripheral module transfers.
7. Do not access the cache (address array, data array, associative purge area).
8. Note that when level detection of the request signal is used in single address mode, the request signal may be detected before DACKn is output.
9. When E_0 exceeds 31.25 MHz, do not use transfer involving DACKn output on ordinary space for word or longword access with an 8-bit bus width, or longword access with a 16-bit bus width.
10. When DMA transfer is performed in response to a DMA transfer request signal from a peripheral module, if clearing of the DMA transfer request signal from the peripheral module by the DMA transfer is not completed before the next transfer request signal from that module, subsequent DMA transfers may not be possible.
11. The following restrictions apply when using dual address mode for 16-byte transfer in cycle-steal mode:
 - a. When external request and level detection are set, do not input DREQn during cycles in which DACKn is not active after the start of DMA transfer.
 - b. When external request DREQ edge detection is set, if DREQn is input continuously the DMAC continues to operate without insertion of a CPU cycle. (However, a CPU cycle will begin if there is no request from DREQn.)

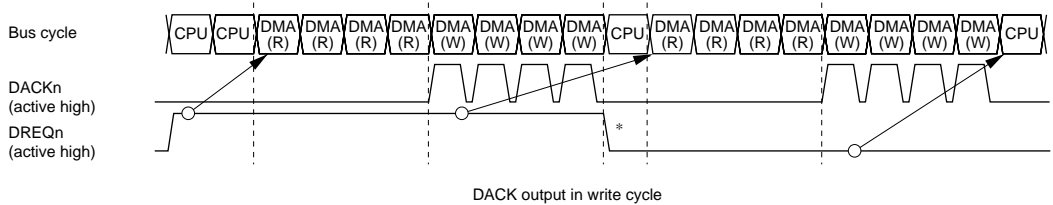
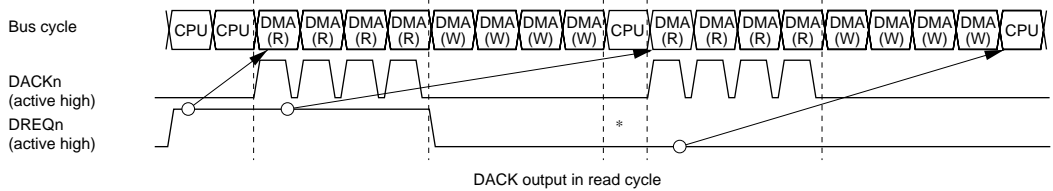

Note: * In addition to CPU cycles, E-DMAC cycles may be inserted in some cases.

12. When setting DMAC channel 0 to cycle-steal mode, and channel 1 to cycle-steal mode, dual address mode or built-in peripheral module request, set the priority mode to priority order fixed mode.
13. When SDRAM is connected, set the upper limit of external bus frequency in DMA single address mode transfers to 31.25 MHz.
14. In the dual address mode, bits TS1 and TS0 (transfer size) in CHCR0 and CHCR1 should be cleared to 00 (byte unit setting) if a destination address as been set in internal memory.

Section 12 16-Bit Free-Running Timer (FRT)

12.1 Overview

A single-channel, 16-bit free-running timer (FRT) is included on-chip. The FRT is based on a 16-bit free-running counter (FRC) and can output two types of independent waveforms. The FRT can also measure the width of input pulses and the cycle of external clocks.

12.1.1 Features

The FRT has the following features:

- Choice of four counter input clocks
The counter input clock can be selected from three internal clocks (Pφ/8, Pφ/32, Pφ/128) and an external clock (enabling external event counting).
- Two independent comparators
Two waveform outputs can be generated.
- Input capture
Choice of rising edge or falling edge
- Counter clear specification
The counter value can be cleared by compare match A.
- Four interrupt sources
Two compare match sources, one input capture source, and one overflow source can issue requests independently.

12.1.2 Block Diagram

Figure 12.1 shows a block diagram of the FRT.

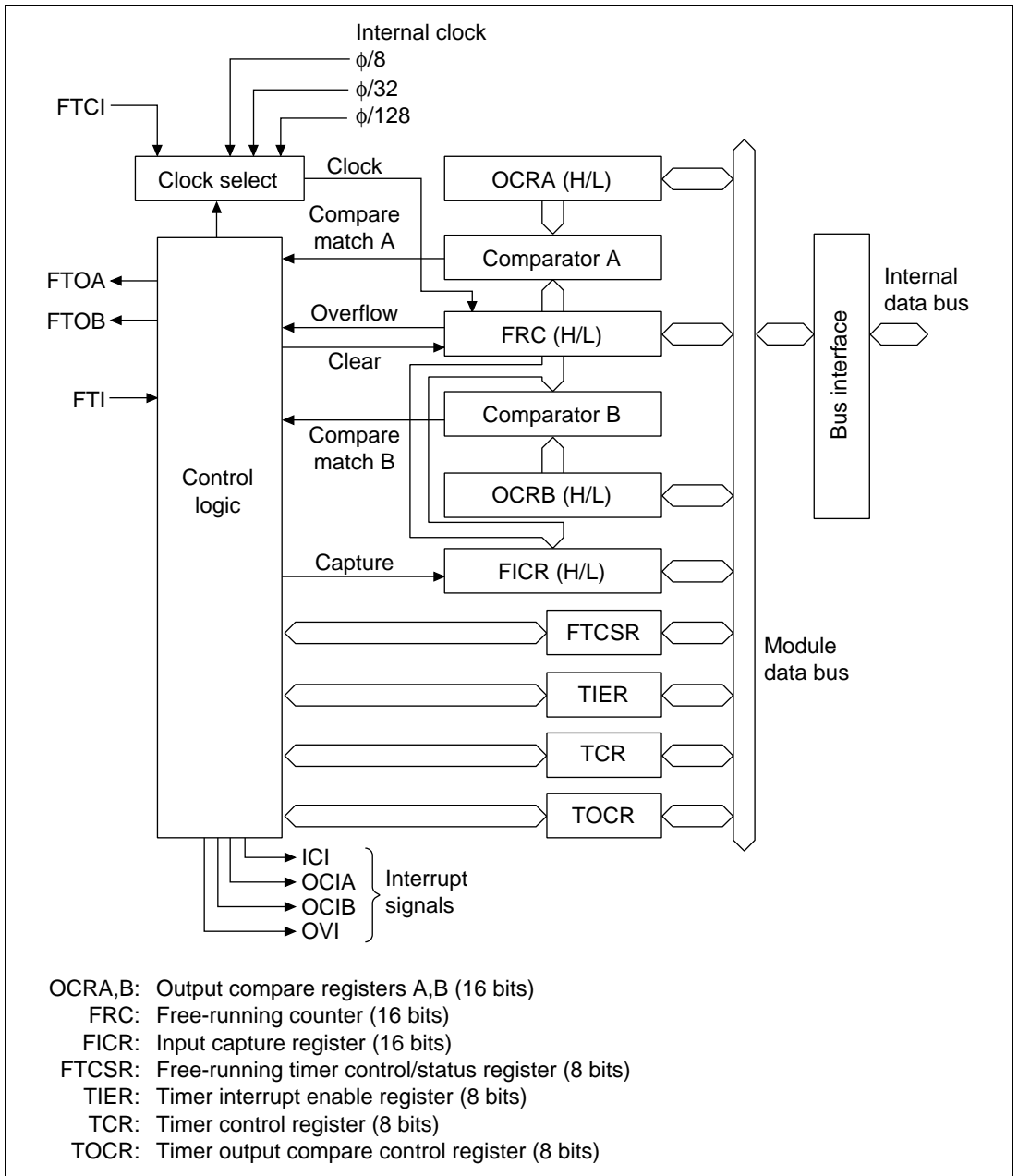

Figure 12.1 FRT Block Diagram

12.1.3 Pin Configuration

Table 12.1 lists FRT I/O pins and their functions.

Table 12.1 Pin Configuration

Channel	Pin	I/O	Function
Counter clock input pin	FTCI	I	FRC counter clock input pin
Output compare A output pin	FTOA	O	Output pin for output compare A
Output compare B output pin	FTOB	O	Output pin for output compare B
Input capture input pin	FTI	I	Input pin for input capture

12.1.4 Register Configuration

Table 12.2 shows the FRT register configuration.

Table 12.2 Register Configuration

Register	Abbreviation	R/W	Initial Value	Address
Timer interrupt enable register	TIER	R/W	H'01	HFFFFFFE10
Free-running timer control/status register	FTCSR	R/(W)* ¹	H'00	HFFFFFFE11
Free-running counter H	FRC H	R/W	H'00	HFFFFFFE12
Free-running counter L	FRC L	R/W	H'00	HFFFFFFE13
Output compare register A H	OCRA H	R/W	H'FF	HFFFFFFE14* ²
Output compare register A L	OCRA L	R/W	H'FF	HFFFFFFE15* ²
Output compare register B H	OCRB H	R/W	H'FF	HFFFFFFE14* ²
Output compare register B L	OCRB L	R/W	H'FF	HFFFFFFE15* ²
Timer control register	TCR	R/W	H'00	HFFFFFFE16
Timer output compare control register	TOCR	R/W	H'E0	HFFFFFFE17
Input capture register H	FICR H	R	H'00	HFFFFFFE18
Input capture register L	FICR L	R	H'00	HFFFFFFE19

Notes: Use byte-size access for all registers.

*1 Bits 7 to 1 are read-only. The only value that can be written is a 0, which is used to clear flags. Bit 0 can be read or written.

*2 OCRA and OCRB have the same address. The OCRS bit in TOCR is used to switch between them.

12.2 Register Descriptions

12.2.1 Free-Running Counter (FRC)

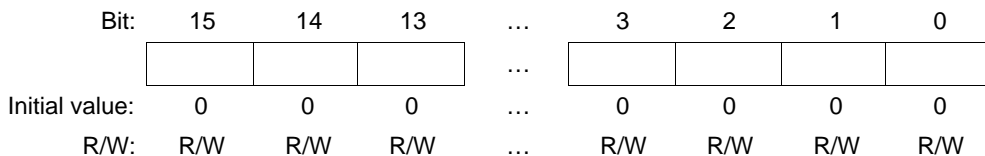

FRC is a 16-bit read/write register. It increments upon input of a clock. The input clock can be selected using clock select bits 1 and 0 (CKS1, CKS0) in TCR. FRC can be cleared upon compare match A.

When FRC overflows (H'FFFF → H'0000), the overflow flag (OVF) in FTCSR is set to 1. FRC can be read or written to by the CPU, but because it is 16 bits long, data transfers involving the CPU are performed via a temporary register (TEMP). See section 12.3, CPU Interface, for more detailed information.

FRC is initialized to H'0000 by a reset, in standby mode, and when the module standby function is used.

12.2.2 Output Compare Registers A and B (OCRA and OCRB)

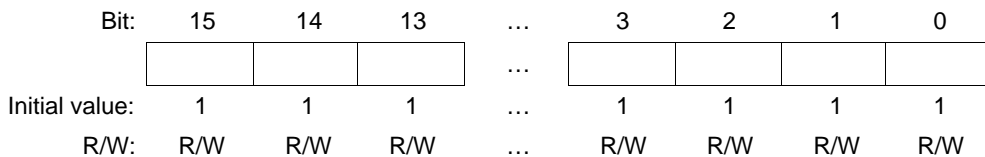

OCR is composed of two 16-bit read/write registers (OCRA and OCRB). The contents of OCR are always compared to the FRC value. When the two values are the same, the output compare flags in FTCSR (OCFA and OCFB) are set to 1.

When the OCR and FRC values are the same (compare match), the output level values set in the output level bits (OLVLA and OLVLB) are output to the output compare pins (FTOA and FTOB). After a reset, FTOA and FTOB output 0 until the first compare match occurs.

Because OCR is a 16-bit register, data transfers involving the CPU are performed via a temporary register (TEMP). See section 12.3, CPU Interface, for more detailed information.

OCR is initialized to H'FFFF by a reset, in standby mode, and when the module standby function is used.

12.2.3 Input Capture Register (FICR)

Bit:	15	14	13	...	3	2	1	0
				...				
Initial value:	0	0	0	...	0	0	0	0
R/W:	R	R	R	...	R	R	R	R

FICR is a 16-bit read-only register. When a rising edge or falling edge of the input capture signal (FTI pin) is detected, the current FRC value is transferred to FICR. At the same time, the input capture flag (ICF) in FTCSR is set to 1. The edge of the input signal can be selected using the input edge select bit (IEDG) in TCR.

Because FICR is a 16-bit register, data transfers involving the CPU are performed via a temporary register (TEMP). See Section 12.3, CPU Interface, for more detailed information. To ensure that the input capture operation is reliably performed, set the pulse width of the input capture input signal to six system clocks (ϕ) or more.

FICR is initialized to H'0000 by a reset, in standby mode, and when the module standby function is used.

12.2.4 Timer Interrupt Enable Register (TIER)

Bit:	7	6	5	4	3	2	1	0
	ICIE	—	—	—	OCIAE	OCIBE	OVIE	—
Initial value:	0	0	0	0	0	0	0	1
R/W:	R/W	R	R	R	R/W	R/W	R/W	R

TIER is an 8-bit read/write register that controls enabling of all interrupt requests. TIER is initialized to H'01 by a reset, in standby mode, and when the module standby function is used.

Bit 7—Input Capture Interrupt Enable (ICIE): Selects enabling/disabling of the ICI interrupt request when the input capture flag (ICF) in FTCSR is set to 1.

Bit 7: ICIE	Description
0	Interrupt request (ICI) caused by ICF disabled (Initial value)
1	Interrupt request (ICI) caused by ICF enabled

Bits 6 to 4—Reserved: These bits are always read as 0. The write value should always be 0.

Bit 3—Output Compare Interrupt A Enable (OCIAE): Selects enabling/disabling of the OCIA interrupt request when the output compare flag A (OCFA) in FTCSR is set to 1.

Bit 3: OCIAE	Description
0	Interrupt request (OCIA) caused by OCFA disabled (Initial value)
1	Interrupt request (OCIA) caused by OCFA enabled

Bit 2—Output Compare Interrupt B Enable (OCIBE): Selects enabling/disabling of the OCIB interrupt request when the output compare flag B (OCFB) in FTCSR is set to 1.

Bit 2: OCIBE	Description
0	Interrupt request (OCIB) caused by OCFB disabled (Initial value)
1	Interrupt request (OCIB) caused by OCFB enabled

Bit 1—Timer Overflow Interrupt Enable (OVIE): Selects enabling/disabling of the OVI interrupt request when the overflow flag (OVF) in FTCSR is set to 1.

Bit 1: OVIE	Description
0	Interrupt request (OVI) caused by OVF disabled (initial value)
1	Interrupt request (OVI) caused by OVF enabled

Bit 0—Reserved: This bit is always read as 1. The write value should always be 1.

12.2.5 Free-Running Timer Control/Status Register (FTCSR)

Bit:	7	6	5	4	3	2	1	0
	ICF	—	—	—	OCFA	OCFB	OVF	CCLRA
Initial value:	0	0	0	0	0	0	0	0
R/W:	R/(W)*	R	R	R	R/(W)*	R/(W)*	R/(W)*	R/W

Note: * For bits 7, and 3 to 1, the only value that can be written is 0 (to clear the flags).

FTCSR is an 8-bit register that selects counter clearing and controls interrupt request signals. FTCSR is initialized to H'00 by a reset, in standby mode, and when the module standby function is used. See section 12.4, Operation, for the timing.

Bit 7—Input Capture Flag (ICF): Status flag that indicates that the FRC value has been sent to FICR by the input capture signal. This flag is cleared by software and set by hardware. It cannot be set by software.

Bit 7: ICF	Description
0	[Clearing condition] When ICF is read while set to 1, and then 0 is written to it (Initial value)
1	[Setting condition] When the FRC value is sent to FICR by the input capture signal

Bits 6 to 4—Reserved: These bits always read 0. The write value should always be 0.

Bit 3—Output Compare Flag A (OCFA): Status flag that indicates when the values of the FRC and OCRA match. This flag is cleared by software and set by hardware. It cannot be set by software.

Bit 3: OCFA	Description
0	[Clearing condition] When OCFA is read while set to 1, and then 0 is written to it (Initial value)
1	[Setting condition] When the FRC value becomes equal to OCRA

Bit 2—Output Compare Flag B (OCFB): Status flag that indicates when the values of FRC and OCRB match. This flag is cleared by software and set by hardware. It cannot be set by software.

Bit 2: OCFB	Description
0	[Clearing condition] When OCFB is read while set to 1, and then 0 is written to it (Initial value)
1	[Setting condition] When the FRC value becomes equal to OCRB

Bit 1—Timer Overflow Flag (OVF): Status flag that indicates when FRC overflows (from H'FFFF to H'0000). This flag is cleared by software and set by hardware. It cannot be set by software.

Bit 1: OVF	Description
0	[Clearing condition] When OVF is read while set to 1, and then 0 is written to it (Initial value)
1	[Setting condition] When the FRC value changes from H'FFFF to H'0000

Bit 0—Counter Clear A (CCLRA): Selects whether or not to clear FRC on compare match A (signal indicating match of FRC and OCRA).

Bit 0: CCLRA	Description
0	FRC clear disabled (Initial value)
1	FRC cleared on compare match A

12.2.6 Timer Control Register (TCR)

Bit:	7	6	5	4	3	2	1	0
	IEDG	—	—	—	—	—	CKS1	CKS0
Initial value:	0	0	0	0	0	0	0	0
R/W:	R/W	R	R	R	R	R	R/W	R/W

TCR is an 8-bit read/write register that selects the input edge for input capture and selects the input clock for FRC. TCR is initialized to H'00 by a reset, in standby mode, and when the module standby function is used.

Bit 7—Input Edge Select (IEDG): Selects whether to capture the input capture input (FTI) on the falling edge or rising edge.

Bit 7: IEDG	Description
0	Input captured on falling edge (Initial value)
1	Input captured on rising edge

Bits 6 to 2—Reserved: These bits are always read as 0. The write value should always be 0.

Bits 1 and 0—Clock Select (CKS1, CKS0): These bits select whether to use an external clock or one of three internal clocks for input to FRC. The external clock is counted at the rising edge.

Bit 1: CKS1	Bit 0: CKS0	Description
0	0	Internal clock: count at $\phi/8$ (Initial value)
	1	Internal clock: count at $\phi/32$
1	0	Internal clock: count at $\phi/128$
	1	External clock: count at rising edge

12.2.7 Timer Output Compare Control Register (TOCR)

Bit:	7	6	5	4	3	2	1	0
	—	—	—	OCRS	—	—	OLVLA	OLVLB
Initial value:	1	1	1	0	0	0	0	0
R/W:	R	R	R	R/W	R	R	R/W	R/W

TOCR is an 8-bit read/write register that selects the output level for output compare and controls switching between access of output compare registers A and B. TOCR is initialized to H'E0 by a reset, in standby mode, and when the module standby function is used.

Bits 7 to 5—Reserved: These bits are always read as 1. The write value should always be 1.

Bit 4—Output Compare Register Select (OCRS): OCRA and OCRB share the same address. The OCRS bit controls which register is selected when reading/writing to this address. It does not affect the operation of OCRA and OCRB.

Bit 4: OCRS	Description
0	OCRA register selected (Initial value)
1	OCRB register selected

Bits 3 and 2—Reserved: These bits are always read as 0. The write value should always be 0.

Bit 1—Output Level A (OLVLA): Selects the level output to the output compare A output pin upon compare match A (signal indicating match of FRC and OCRA).

Bit 1: OLVLA	Description
0	0 output on compare match A (Initial value)
1	1 output on compare match A

Bit 0—Output Level B (OLVLB): Selects the level output to the output compare B output pin upon compare match B (signal indicating match of FRC and OCRB).

Bit 0: OLVLB	Description
0	0 output on compare match B (Initial value)
1	1 output on compare match B

12.3 CPU Interface

FRC, OCRA, OCRB, and FICR are 16-bit registers. The data bus width between the CPU and FRT, however, is only 8 bits. Access of these three types of registers from the CPU therefore needs to be performed via an 8-bit temporary register called TEMP.

The following describes how these registers are read from and written to:

- **Writing to 16-bit Registers**
The upper byte is written, which results in the upper byte of data being stored in TEMP. The lower byte is then written, which results in 16 bits of data being written to the register when combined with the upper byte value in TEMP.
- **Reading from 16-bit Registers**
The upper byte of data is read, which results in the upper byte value being transferred to the CPU. The lower byte value is transferred to TEMP. The lower byte is then read, which results in the lower byte value in TEMP being sent to the CPU.

When registers of these three types are accessed, two byte accesses should always be performed, first to the upper byte, then the lower byte. If only the upper byte or lower byte is accessed, the data will not be transferred properly.

Figure 12.2 and 12.3 show the flow of data when FRC is accessed. Other registers function in the same way. When reading OCRA and OCRB, however, both upper and lower-byte data is transferred directly to the CPU without passing through TEMP.

(Write to upper byte)

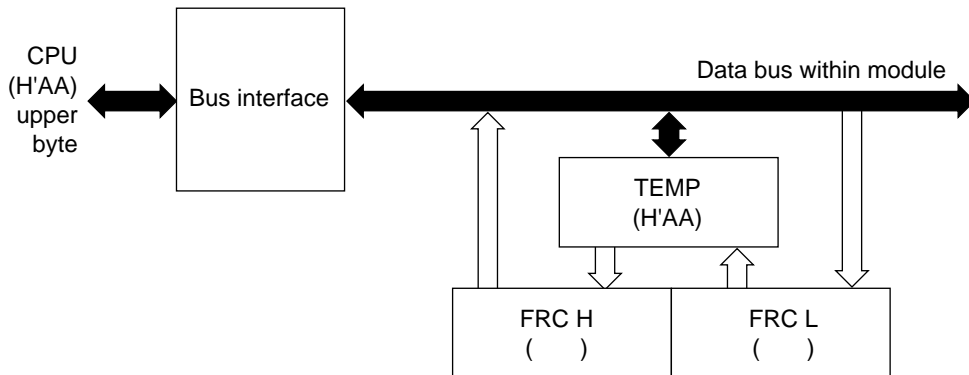

(Write to lower byte)

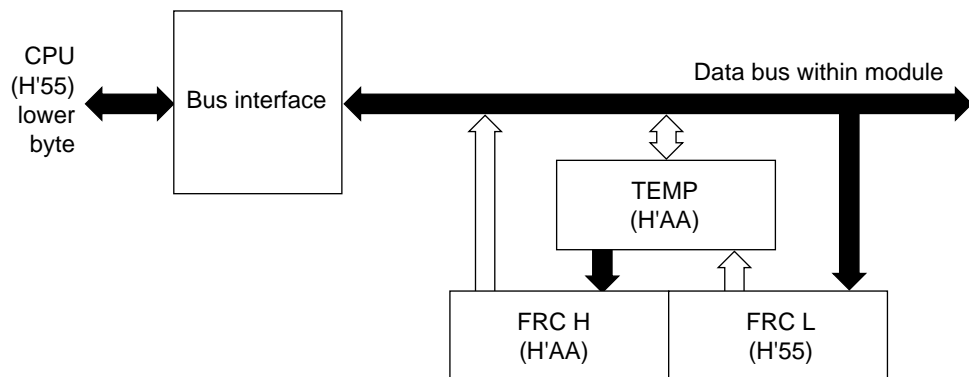

Figure 12.2 FRC Access Operation (CPU Writes H'AA55 to FRC)

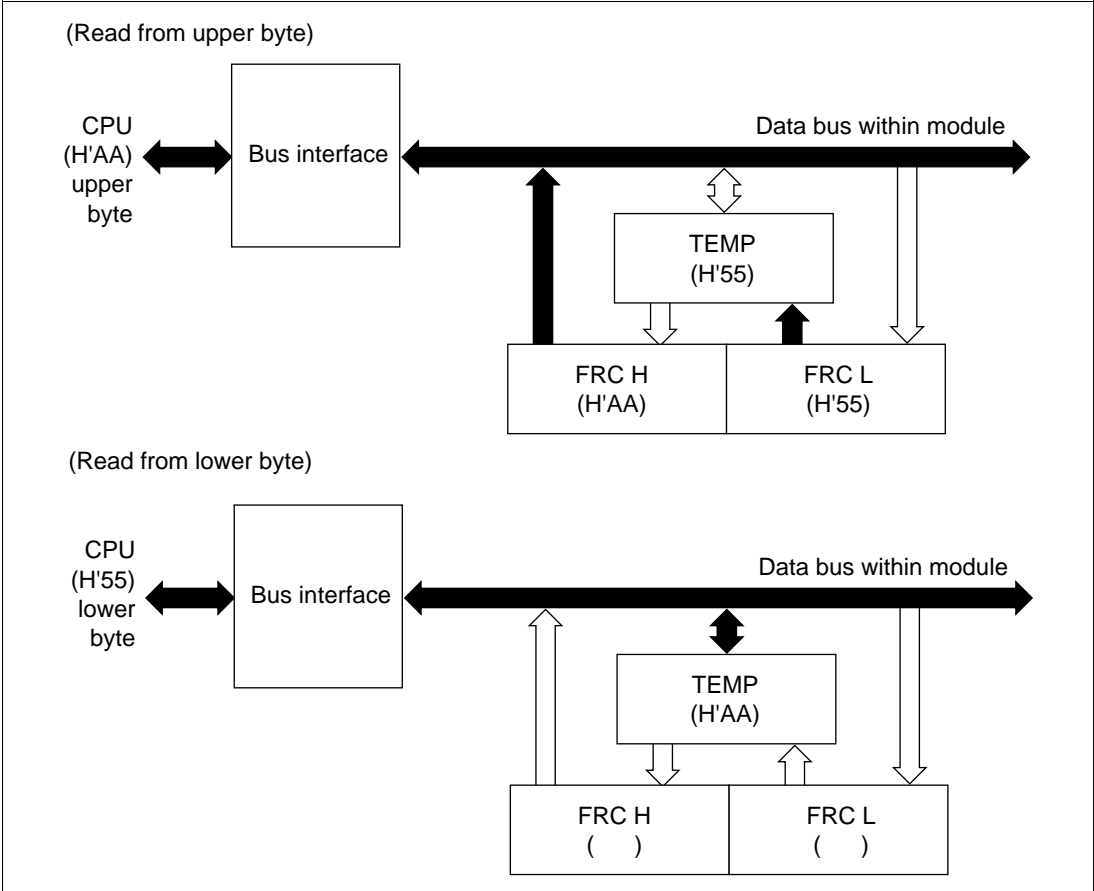

Figure 12.3 FRC Access Operation (CPU Reads H'AA55 from FRC)

12.4 Operation

12.4.1 FRC Count Timing

The FRC increments on clock input (internal or external).

Internal Clock Operation: Set the CKS1 and CKS0 bits in TCR to select which of the three internal clocks created by dividing system clock ϕ ($\phi/8$, $\phi/32$, $\phi/128$) is used. Figure 12.4 shows the timing.

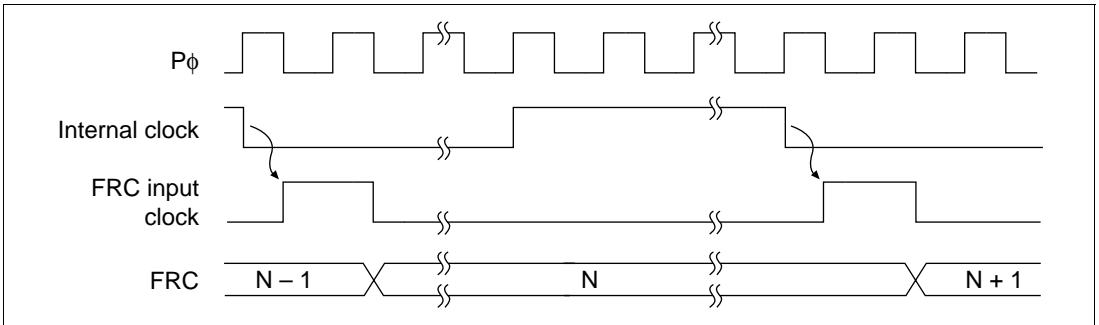

Figure 12.4 Count Timing (Internal Clock Operation)

External Clock Operation: Set the CKS1 and CKS0 bits in TCR to select the external clock. External clock pulses are counted on the rising edge. The pulse width of the external clock must be at least 6 system clocks (ϕ). A smaller pulse width will result in inaccurate operation. Figures 12.5 shows the timing.

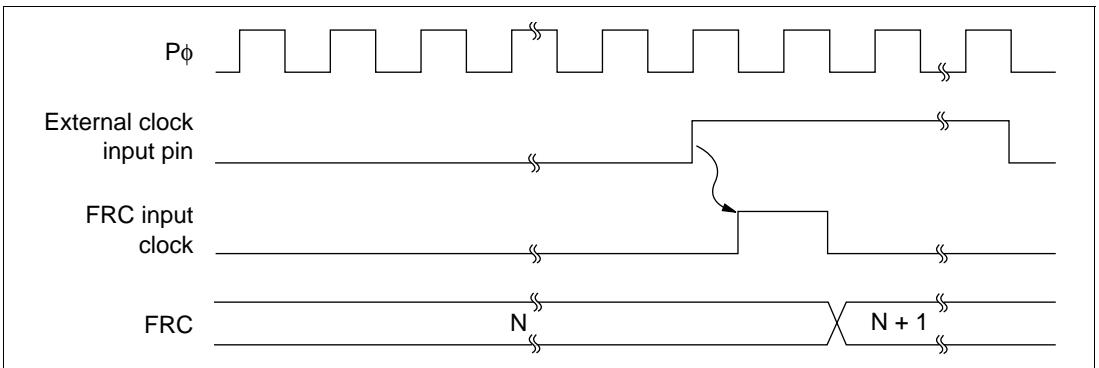

Figure 12.5 Count Timing (External Clock Operation)

12.4.2 Output Timing for Output Compare

When a compare match occurs, the output level set in the OLVL bit in TOCR is output from the output compare output pins (FTOA, FTOB). Figure 12.6 shows the timing for output of output compare A.

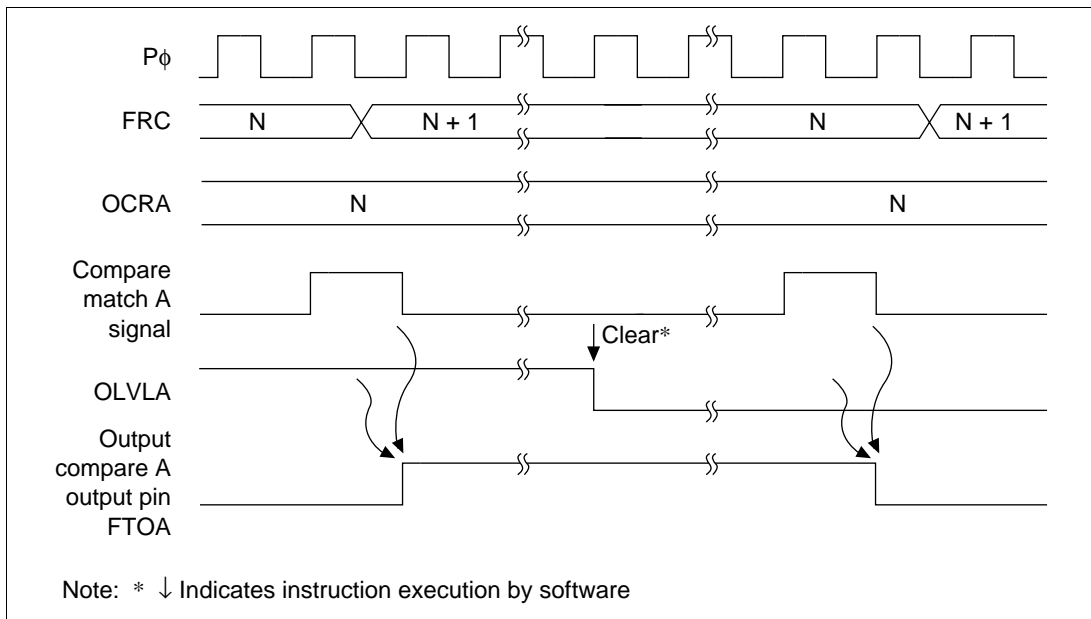

Figure 12.6 Output Timing for Output Compare A

12.4.3 FRC Clear Timing

FRC can be cleared on compare match A. Figure 12.7 shows the timing.

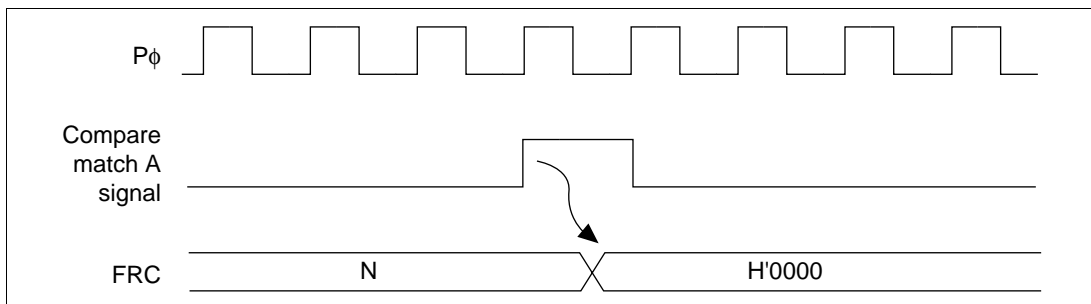

Figure 12.7 Compare Match A Clear Timing

12.4.4 Input Capture Input Timing

Either the rising edge or falling edge can be selected for input capture input using the IEDG bit in TCR. Figure 12.8 shows the timing when the rising edge is selected (IEDG = 1).

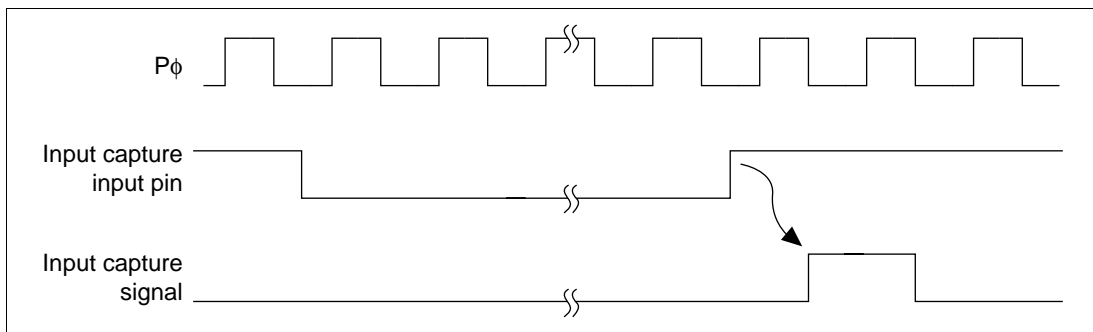

Figure 12.8 Input Capture Signal Timing (Normal)

When the input capture signal is input when FICR is read (upper-byte read), the input capture signal is delayed by one cycle of $P\phi$. Figure 12.9 shows the timing.

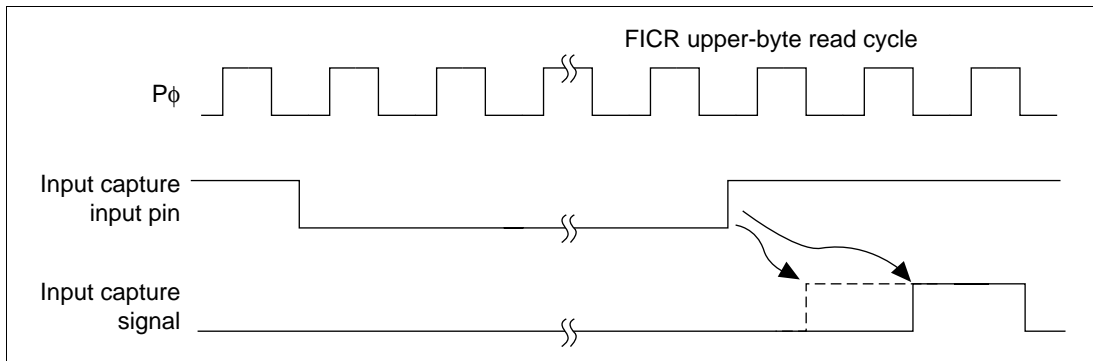

Figure 12.9 Input Capture Signal Timing (Input Capture Input when FICR is Read)

12.4.5 Input Capture Flag (ICF) Setting Timing

Input capture input sets the input capture flag (ICF) to 1 and simultaneously transfers the FRC value to FICR. Figure 12.10 shows the timing.

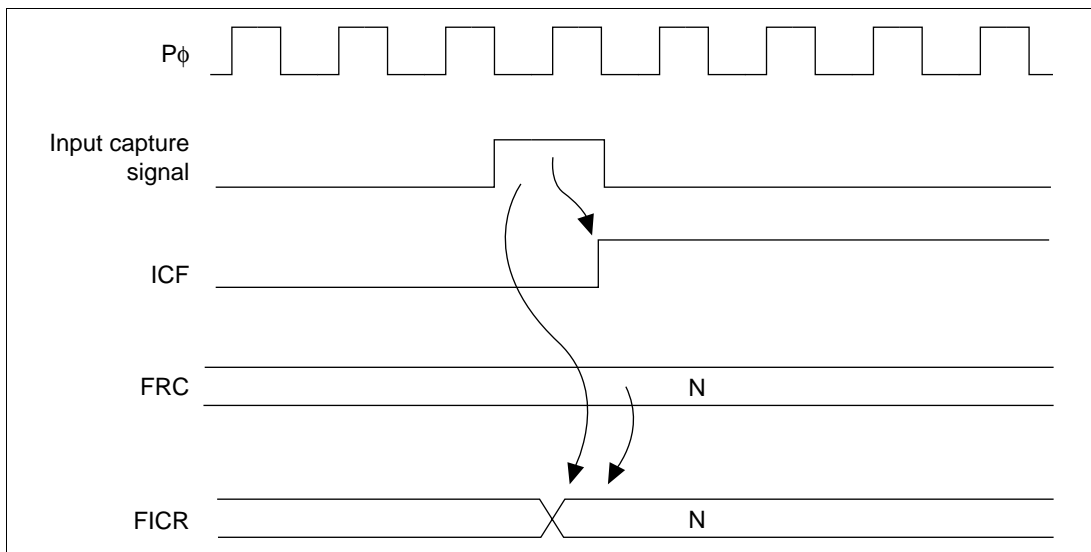

Figure 12.10 ICF Setting Timing

12.4.6 Output Compare Flag (OCFA, OCFB) Setting Timing

The compare match signal output (when OCRA or OCRB matches the FRC value) sets output compare flag OCFA or OCFB to 1. The compare match signal is generated in the last state in which the values matched (at the timing for updating the count value that matched the FRC). After OCRA or OCRB matches the FRC, no compare match is generated until the next increment occurs. Figure 12.11 shows the timing for setting OCFA and OCFB.

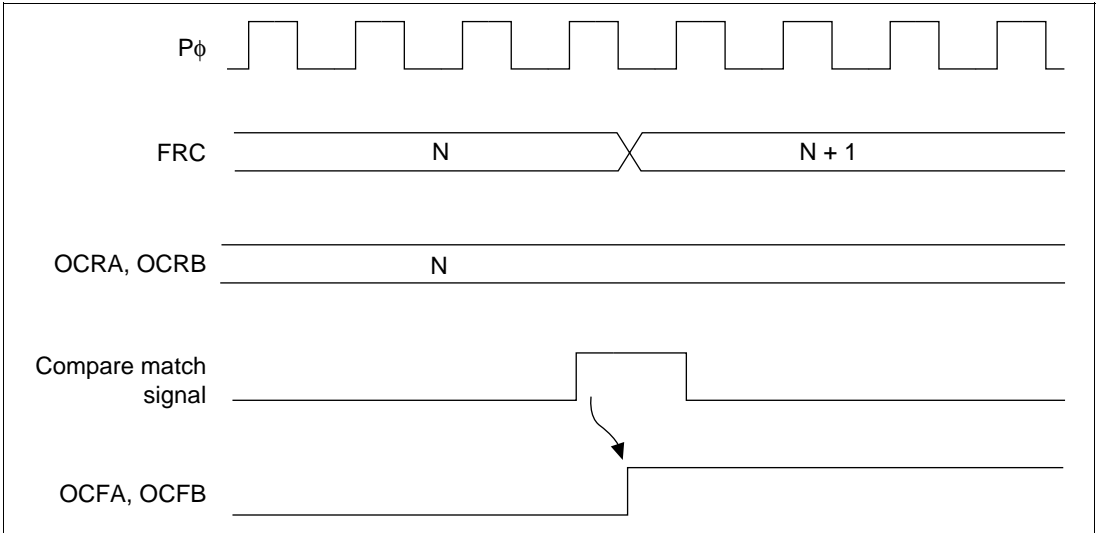

Figure 12.11 OCF Setting Timing

12.4.7 Timer Overflow Flag (OVF) Setting Timing

FRC overflow (from H'FFFF to H'0000) sets the timer overflow flag (OVF) to 1. Figure 12.12 shows the timing.

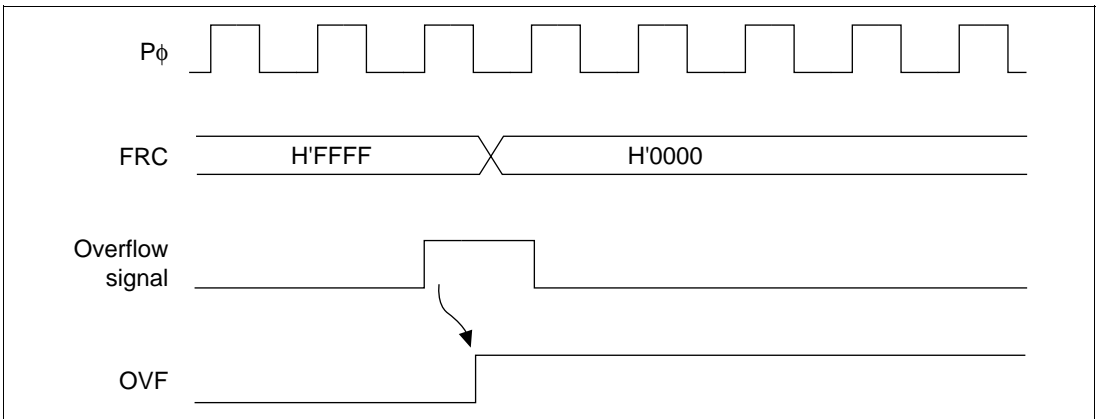

Figure 12.12 OVF Setting Timing

12.5 Interrupt Sources

There are four FRT interrupt sources of three types (ICI, OCIA/OCIB, and OVI). Table 12.3 lists the interrupt sources and their priorities after a reset is cleared. The interrupt enable bits in TIER are used to enable or disable the interrupt bits. Each interrupt request is sent to the interrupt controller independently. See section 5, Interrupt Controller (INTC), for more information about priorities and the relationship to interrupts other than those of the FRT.

Table 12.3 FRT Interrupt Sources and Priorities

Interrupt Source	Description	Priority
ICI	Interrupt by ICF	High
OCIA, OCIB	Interrupt by OCFA or OCFB	↕
OVI	Interrupt by OVF	Low

12.6 Example of FRT Use

Figure 12.13 shows an example in which pulses with a 50% duty factor and arbitrary phase relationship are output. The procedure is as follows:

1. Set the CCLRA bit in FTCSR to 1.
2. The OLVLA and OLVLB bits are inverted by software whenever a compare match occurs.

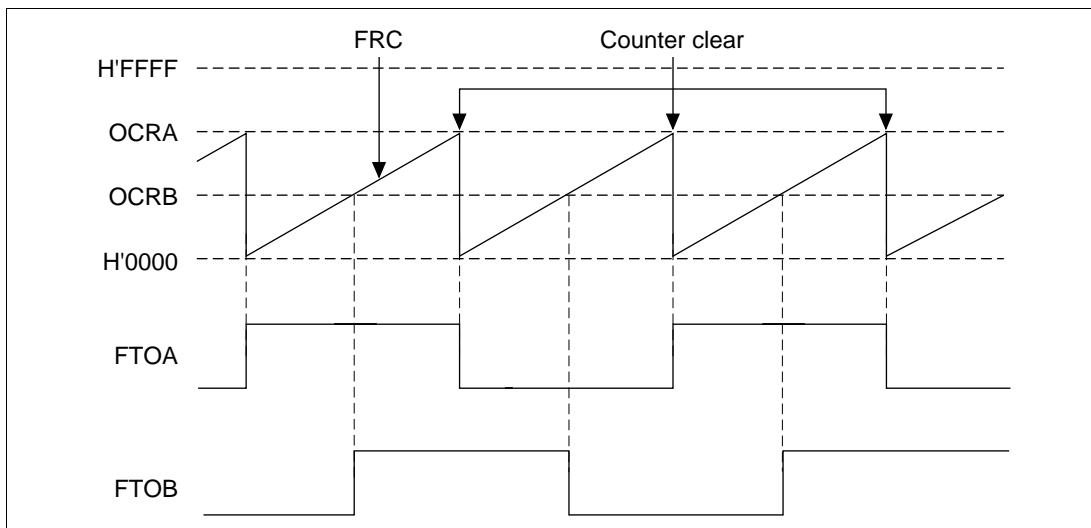

Figure 12.13 Example of Pulse Output

12.7 Usage Notes

Note that the following contention and operations occur when the FRT is operating:

12.7.1 Contention between FRC Write and Clear

When a counter clear signal is generated with the timing shown in figure 12.14 during the write cycle for the lower byte of FRC, writing does not occur to the FRC, and the FRC clear takes priority.

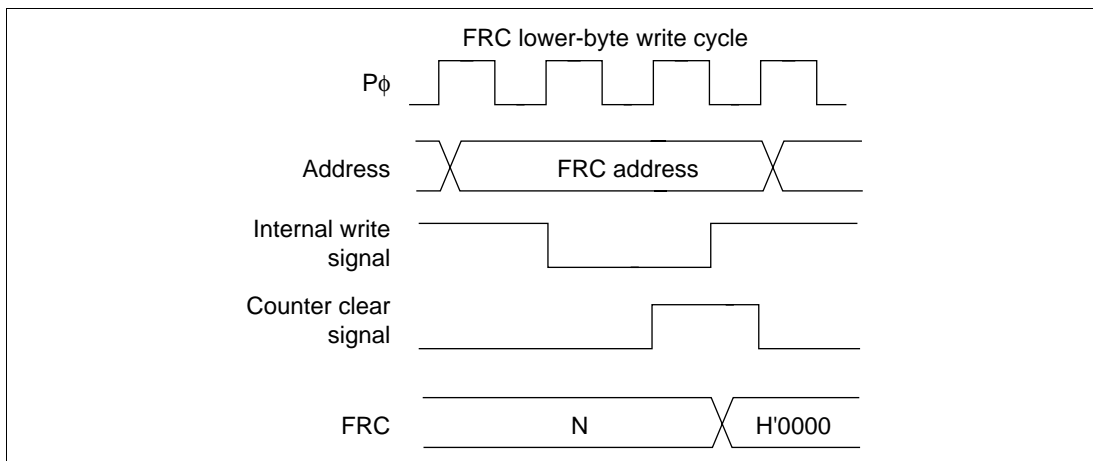

Figure 12.14 Contention between FRC Write and Clear

12.7.2 Contention between FRC Write and Increment

When an increment occurs with the timing shown in figure 12.15 during the write cycle for the lower byte of FRC, no increment is performed and the counter write takes priority.

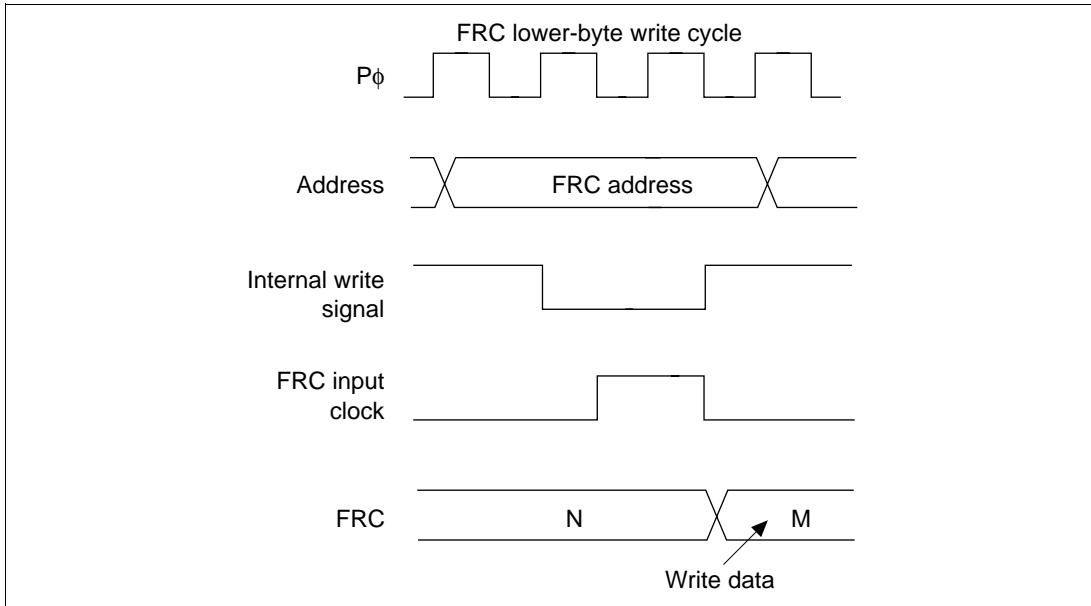

Figure 12.15 Contention between FRC Write and Increment

12.7.3 Contention between OCR Write and Compare Match

When a compare match occurs with the timing shown in figure 12.16, during the write cycle for the lower byte of OCRA or OCRB, the OCR write takes priority and the compare match signal is disabled.

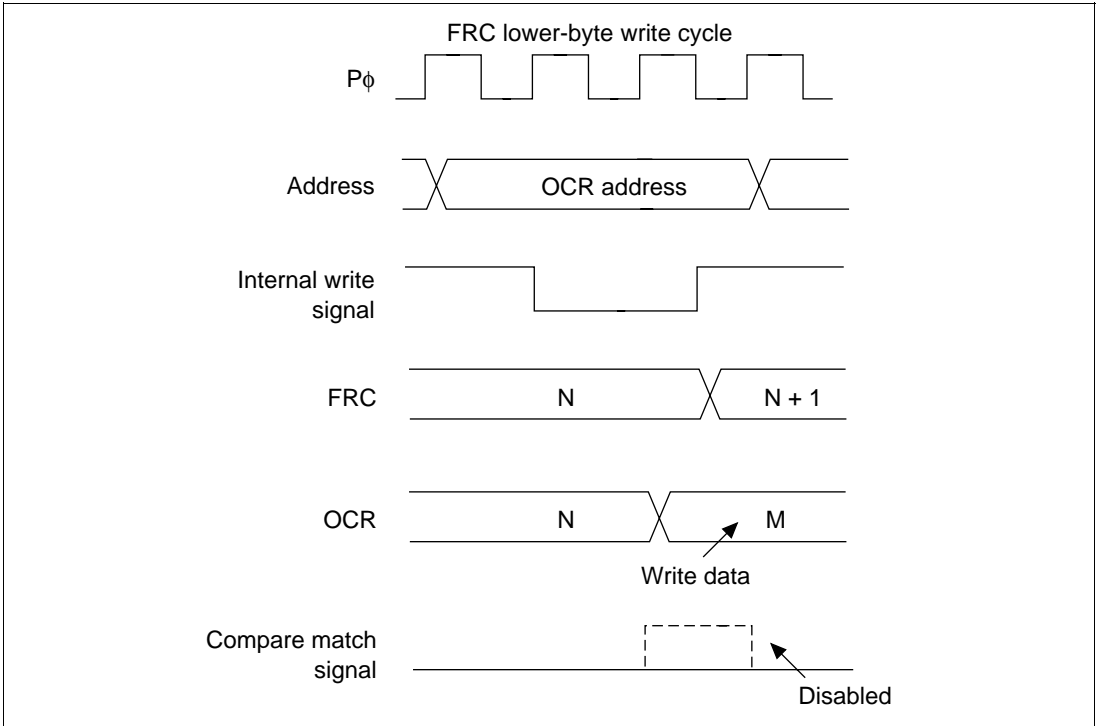

Figure 12.16 Contention between OCR and Compare Match

12.7.4 Internal Clock Switching and Counter Operation

FRC will sometimes begin incrementing because of the timing of switching between internal clocks. Table 12.4 shows the relationship between internal clock switching timing (CKS1 and CKS0 bit rewrites) and FRC operation.

When an internal clock is used, the FRC clock is generated when the falling edge of an internal clock (created by dividing the system clock (ϕ)) is detected. When a clock is switched to high before the switching and to low after switching, as shown in case 3 in table 12.4, the switchover is considered a falling edge and an FRC clock pulse is generated, causing FRC to increment. FRC may also increment when switching between an internal clock and an external clock.

Table 12.4 Internal Clock Switching and FRC Operation

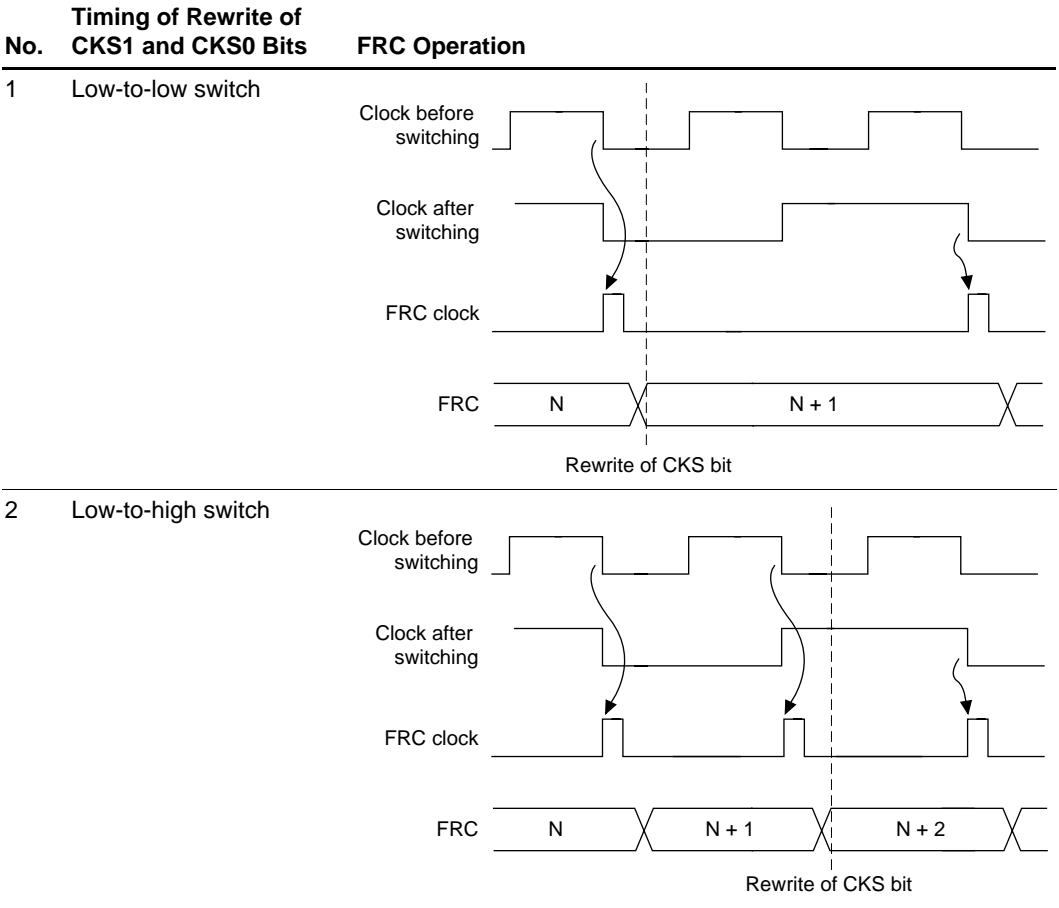

Table 12.4 Internal Clock Switching and FRC Operation (cont)

No.	Timing of Rewrite of CKS1 and CKS0 Bits	FRC Operation
3	High-to-low switch	<p>The diagram for a high-to-low switch shows the transition of the clock signal from a high state to a low state. The 'Clock before switching' signal is high, and the 'Clock after switching' signal is low. The 'FRC clock' signal shows a pulse at the transition point, which is circled. The 'FRC' signal shows counts N, N+1, and N+2. A vertical dashed line marks the 'Rewrite of CKS bit'.</p>
4	High-to-high switch	<p>The diagram for a high-to-high switch shows the transition of the clock signal from a low state to a high state. The 'Clock before switching' signal is low, and the 'Clock after switching' signal is high. The 'FRC clock' signal shows a pulse at the transition point. The 'FRC' signal shows counts N, N+1, and N+2. A vertical dashed line marks the 'Rewrite of CKS bit'.</p>

Note: Because the switchover is considered a falling edge, FRC starts counting up.

12.7.5 Timer Output (FTOA, FTOB)

During a power-on reset, the timer outputs (FTOA, FTOB) will be unreliable until the oscillation stabilizes. The initial value is output after the oscillation settling time has elapsed.

Section 13 Watchdog Timer (WDT)

13.1 Overview

A single-channel watchdog timer (WDT) is provided on-chip for monitoring system operations. If a system becomes uncontrolled and the timer counter overflows without being rewritten correctly by the CPU, an overflow signal ($\overline{\text{WDTOVF}}$) is output externally. The WDT can simultaneously generate an internal reset signal for the entire chip.

When this watchdog function is not needed, the WDT can be used as an interval timer. In the interval timer operation, an interval timer interrupt is generated at each counter overflow. The WDT is also used when recovering from standby mode, in modifying a clock frequency, and in clock pause mode.

13.1.1 Features

The WDT includes the following features.

- Can be switched between watchdog timer mode and interval timer mode.
- $\overline{\text{WDTOVF}}$ output in watchdog timer mode

The $\overline{\text{WDTOVF}}$ signal is output externally when the counter overflows, and a simultaneous internal reset of the chip can also be selected (either a power-on reset or manual reset can be specified).

- Interrupt generation in interval timer mode

An interval timer interrupt is generated when the counter overflows.

- Used when standby mode is cleared or the clock frequency is changed, and in clock pause mode.
- Choice of eight counter input clocks

13.1.2 Block Diagram

Figure 13.1 shows a block diagram of the WDT.

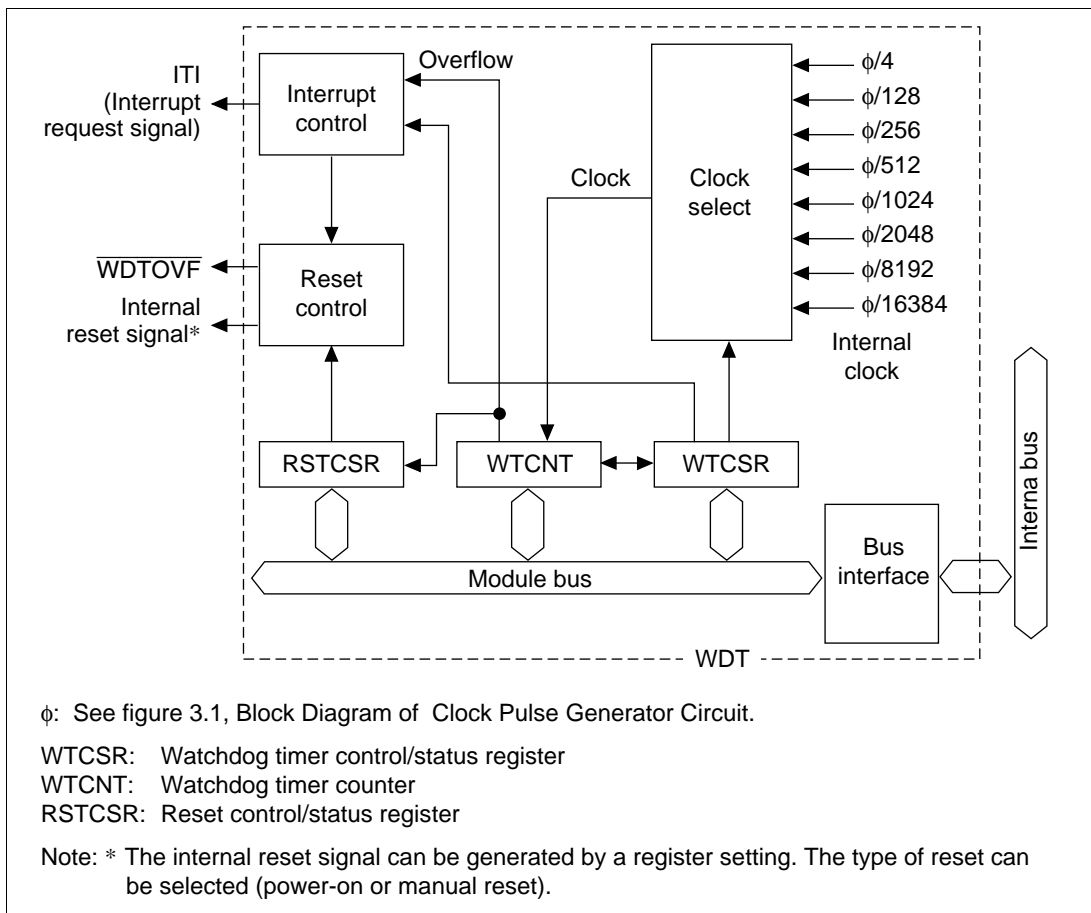

Figure 13.1 WDT Block Diagram

13.1.3 Pin Configuration

Table 13.1 shows the pin configuration.

Table 13.1 Pin Configuration

Pin	Abbreviation	I/O	Function
Watchdog timer overflow	WDTOVF	O	Outputs the counter overflow signal in watchdog timer mode

13.1.4 Register Configuration

Table 13.2 summarizes the three WDT registers. They are used to select the clock, switch the WDT mode, and control the reset signal.

Table 13.2 Register Configuration

Name	Abbreviation	R/W	Initial Value	Address	
				Write* ¹	Read* ²
Watchdog timer control/status register	WTCSR	R/(W)* ³	H'18	H'FFFFFFE80	H'FFFFFFE80
Watchdog timer counter	WTCNT	R/W	H'00	H'FFFFFFE80	H'FFFFFFE81
Reset control/status register	RSTCSR	R/(W)* ³	H'1D	H'FFFFFFE82	H'FFFFFFE83

Notes: *1 Write by word access. It cannot be written by byte or longword access.

*2 Read by byte access. The correct value cannot be read by word or longword access.

*3 Only 0 can be written in bit 7 to clear the flag.

13.2 Register Descriptions

13.2.1 Watchdog Timer Counter (WTCNT)

Bit:	7	6	5	4	3	2	1	0
Initial value:	0	0	0	0	0	0	0	0
R/W:	R/W	R/W	R/W	R/W	R/W	R/W	R/W	R/W

WTCNT is an 8-bit read/write register. The method of writing to WTCNT differs from that of most other registers to prevent inadvertent rewriting. See section 13.2.4, Notes on Register Access, for details. When the timer enable bit (TME) in the watchdog timer control/status register (WTCSR) is set to 1, the watchdog timer counter starts counting pulses of an internal clock source selected by clock select bits 2 to 0 (CKS2 to CKS0) in WTCSR. When the value of WTCNT overflows (changes from H'FF to H'00), a watchdog timer overflow signal ($\overline{\text{WDTOVF}}$) or interval timer interrupt (ITI) is generated, depending on the mode selected in the WT/IT bit in WTCSR. WTCNT is initialized to H'00 by a reset and when the TME bit is cleared to 0. It is not initialized in standby mode, when the clock frequency is changed, or in clock pause mode.

13.2.2 Watchdog Timer Control/Status Register (WTCSR)

Bit:	7	6	5	4	3	2	1	0
	OVF	WT/ $\overline{\text{IT}}$	TME	—	—	CKS2	CKS1	CKS0
Initial value:	0	0	0	1	1	0	0	0
R/W:	R/(W)*	R/W	R/W	R	R	R/W	R/W	R/W

Note: * Only 0 can be written in bit 7, to clear the flag.

The watchdog timer control/status register (WTCSR) is an 8-bit read/write register. The method of writing to WTCSR differs from that of most other registers to prevent inadvertent rewriting. See section 13.2.4, Notes on Register Access, for details. Its functions include selecting the timer mode and clock source. Bits 7 to 5 are initialized to 000 by a reset, in standby mode, when the clock frequency is changed, and in clock pause mode. Bits 2 to 0 are initialized to 000 by a reset, but are not initialized in standby mode, when the clock frequency is changed, or in clock pause mode.

Bit 7—Overflow Flag (OVF): Indicates that WTCNT has overflowed from H'FF to H'00 in interval timer mode. It is not set in watchdog timer mode.

Bit 7: OVF	Description
0	No overflow of WTCNT in interval timer mode (Initial value) Cleared by reading OVF, then writing 0 in OVF
1	WTCNT overflow in interval timer mode

Bit 6—Timer Mode Select (WT/ $\overline{\text{IT}}$): Selects whether to use the WDT as a watchdog timer or interval timer. When WTCNT overflows, the WDT either generates an interval timer interrupt (ITI) or generates a $\overline{\text{WDTOVF}}$ signal, depending on the mode selected.

Bit 6: WT/ $\overline{\text{IT}}$	Description
0	Interval timer mode: interval timer interrupt (ITI) request to the CPU when WTCNT overflows (Initial value)
1	Watchdog timer mode: $\overline{\text{WDTOVF}}$ signal output externally when WTCNT overflows. Section 13.2.3, Reset Control/Status Register (RSTCSR), describes in detail what happens when WTCNT overflows in watchdog timer mode

Bit 5—Timer Enable (TME): Enables or disables the timer.

Bit 5: TME	Description
0	Timer disabled: WTCNT is initialized to H'00 and count-up stops (Initial value)
1	Timer enabled: WTCNT starts counting. A $\overline{\text{WDT0VF}}$ signal or interrupt is generated when WTCNT overflows

Bits 4 and 3—Reserved: These bits are always read as 1. The write value should always be 1.

Bits 2 to 0—Clock Select 2 to 0 (CKS2 to CKS0): These bits select one of eight internal clock sources for input to WTCNT. The clock signals are obtained by dividing the frequency of the system clock (ϕ).

				Description	
Bit 2: CKS2	Bit 1: CKS1	Bit 0: CKS0	Clock Source	Overflow Interval* ($\phi = 60 \text{ MHz}$)	
0	0	0	$\phi/4$ (Initial value)	17.0 μs	
		1	$\phi/128$	544 μs	
	1	0	$\phi/256$	1.1 ms	
		1	$\phi/512$	2.2 ms	
1	0	0	$\phi/1024$	4.4 ms	
		1	$\phi/2048$	8.7 ms	
	1	0	$\phi/8192$	34.8 ms	
		1	$\phi/16384$	69.6 ms	

Note: * The overflow interval listed is the time from when the WTCNT begins counting at H'00 until an overflow occurs.

13.2.3 Reset Control/Status Register (RSTCSR)

Bit:	7	6	5	4	3	2	1	0
	WOVF	RSTE	RSTS	—	—	—	—	—
Initial value:	0	0	0	1	1	1	0	1
R/W:	R/(W)*	R/W	R/W	R	R	R	R	R

Note: * Only 0 can be written in bit 7, to clear the flag.

RSTCSR is an 8-bit read/write register that controls output of the reset signal generated by watchdog timer counter (WTCNT) overflow and selects the internal reset signal type. The method of writing to RSTCSR differs from that of most other registers to prevent inadvertent rewriting. See section 13.2.4, Notes on Register Access, for details. RSTCSR is initialized to H'1D by input of

a reset signal from the $\overline{\text{RES}}$ pin, but is not initialized by the internal reset signal generated by overflow of the WDT. It is initialized to H'1D in standby mode, when the clock frequency is changed, and in clock pause mode.

Bit 7—Watchdog Timer Overflow Flag (WOVF): Indicates that WTCNT has overflowed (from H'FF to H'00) in watchdog timer mode. It is not set in interval timer mode.

Bit 7: WOVF	Description
0	No WTCNT overflow in watchdog timer mode (Initial value) Cleared by reading WOVF, then writing 0 in WOVF
1	Set by WTCNT overflow in watchdog timer mode

Bit 6—Reset Enable (RSTE): Selects whether to reset the chip internally if WTCNT overflows in watchdog timer mode.

Bit 6: RSTE	Description
0	Not reset when WTCNT overflows (Initial value) LSI not reset internally, but WTCNT and WTCSR reset within WDT
1	Reset when WTCNT overflows

Bit 5—Reset Select (RSTS): Selects the type of internal reset generated if WTCNT overflows in watchdog timer mode.

Bit 5: RSTS	Description
0	Power-on reset (Initial value)
1	Manual reset

Bits 4 to 2, bit 0—Reserved: These bits are always read as 1. The write value should always be 1.

Bit 1—Reserved: This bit is always read as 0. The write value should always be 0.

13.2.4 Notes on Register Access

The watchdog timer's WTCNT, WTCSR, and RSTCSR registers differ from other registers in that they are more difficult to write. The procedures for writing and reading these registers are given below.

Writing to WTCNT and WTCSR: These registers must be written by a word transfer instruction. They cannot be written by byte or longword transfer instructions. WTCNT and WTCSR both have the same write address. The write data must be contained in the lower byte of

the written word. The upper byte must be H'5A (for WTCNT) or H'A5 (for WTCSR) (figure 13.2). This transfers the write data from the lower byte to WTCNT or WTCSR.

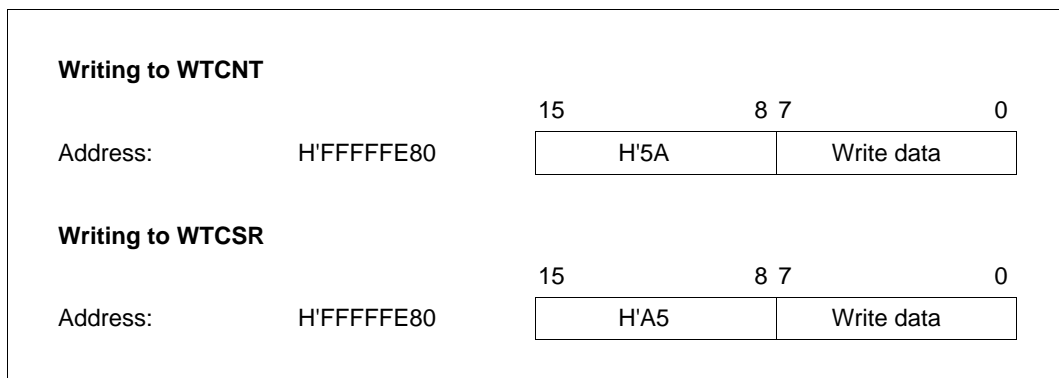

Figure 13.2 Writing to WTCNT and WTCSR

Writing to RSTCSR: RSTCSR must be written by a word access to address H'FFFFFFE82. It cannot be written by byte or longword transfer instructions. Procedures for writing 0 in WOVF (bit 7) and for writing to RSTE (bit 6) and RSTS (bit 5) are different, as shown in figure 13.3. To write 0 in the WOVF bit, the write data must be H'A5 in the upper byte and H'00 in the lower byte. This clears the WOVF bit to 0. The RSTE and RSTS bits are not affected. To write to the RSTE and RSTS bits, the upper byte must be H'5A and the lower byte must be the write data. The values of bits 6 and 5 of the lower byte are transferred to the RSTE and RSTS bits, respectively. The WOVF bit is not affected.

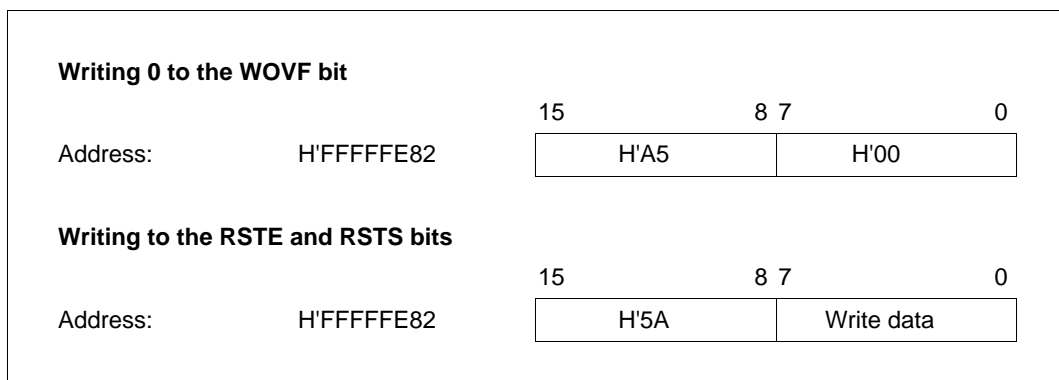

Figure 13.3 Writing to RSTCSR

Reading from WTCNT, WTCSR, and RSTCSR: WTCNT, WTCSR, and RSTCSR are read like other registers. Use byte transfer instructions. The read addresses are H'FFFFFFE80 for WTCSR, H'FFFFFFE81 for WTCNT, and H'FFFFFFE83 for RSTCSR.

13.3 Operation

13.3.1 Operation in Watchdog Timer Mode

To use the WDT as a watchdog timer, set the $\overline{WT/IT}$ and TME bits in WTCSR to 1. Software must prevent WTCNT overflow by rewriting the WTCNT value (normally by writing H'00) before overflow occurs. Thus, WTCNT will not overflow while the system is operating normally, but if WTCNT fails to be rewritten and overflows occur due to a system crash or the like, a \overline{WDTOVF} signal is output (figure 13.4). The \overline{WDTOVF} signal can be used to reset the system. The \overline{WDTOVF} signal is output for 512 ϕ clock cycles.

If the RSTE bit in RSTCSR is set to 1, a signal to reset the chip will be generated internally simultaneously with the \overline{WDTOVF} signal when WTCNT overflows. Either a power-on reset or a manual reset can be selected by the RSTS bit. The internal reset signal is output for 2048 ϕ clock cycles.

If a reset due to the input signal from the \overline{RES} pin and a reset due to WDT overflow occur simultaneously, the \overline{RES} reset takes priority and the WOVF bit in RSTCSR is cleared to 0.

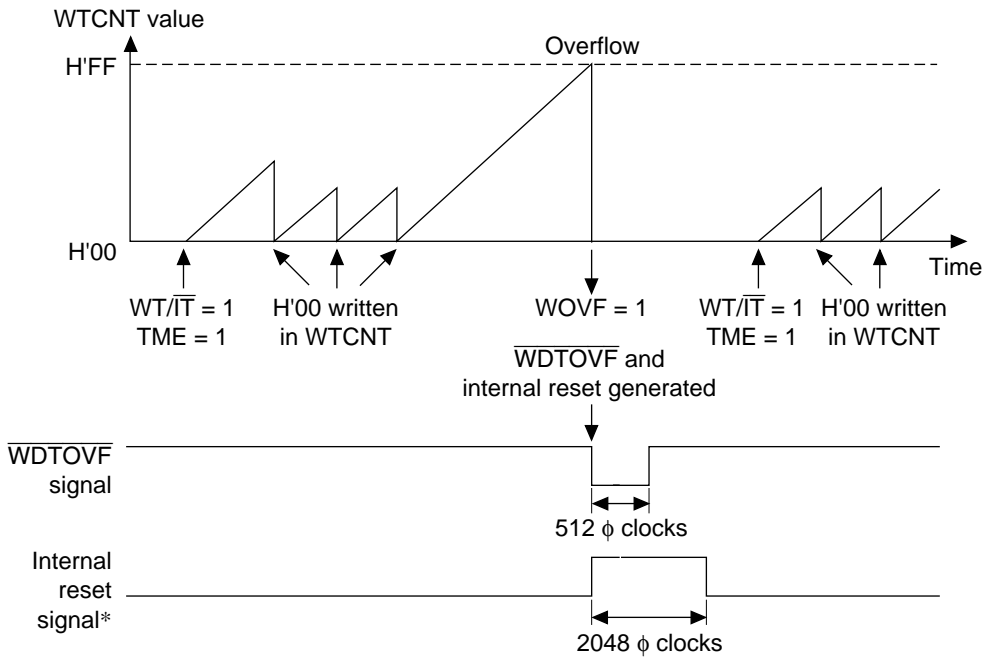

WT/IT: Timer mode select bit
TME: Timer enable bit

Note: * Internal reset signal is generated only when the RSTE bit is set to 1.

Figure 13.4 Operation in Watchdog Timer Mode

13.3.2 Operation in Interval Timer Mode

To use the WDT as an interval timer, clear $\overline{WT/IT}$ to 0 and set TME to 1 in WTCSR. An interval timer interrupt (ITI) is generated each time the watchdog timer counter (WTCNT) overflows. This function can be used to generate interval timer interrupts at regular intervals (figure 13.5).

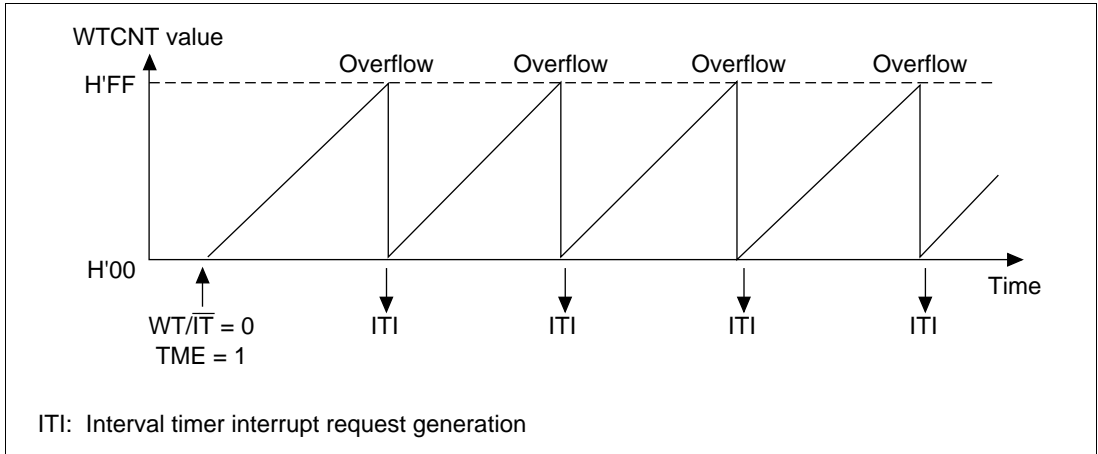

Figure 13.5 Operation in Interval Timer Mode

13.3.3 Operation when Standby Mode is Cleared

The watchdog timer has a special function to clear standby mode with an NMI interrupt. When using standby mode, set the WDT as described below.

Transition to Standby Mode: The TME bit in WTCSR must be cleared to 0 to stop the watchdog timer counter before it enters standby mode. The chip cannot enter standby mode while the TME bit is set to 1. Set bits CKS2 to CKS0 in WTCSR so that the counter overflow interval is equal to or longer than the oscillation settling time. See section 22, Electrical Characteristics, for the oscillation settling time.

Recovery from Standby Mode: When an NMI request signal is received in standby mode the clock oscillator starts running and the watchdog timer starts counting at the rate selected by bits CKS2 to CKS0 before standby mode was entered. When WTCNT overflows (changes from H'FF to H'00) the system clock (ϕ) is presumed to be stable and usable; clock signals are supplied to the entire chip and standby mode ends.

For details on standby mode, see section 21, Power Down Modes.

13.3.4 Timing of Overflow Flag (OVF) Setting

In interval timer mode, when WTCNT overflows, the OVF flag in WTCSR is set to 1 and an interval timer interrupt (ITI) is requested (figure 13.6).

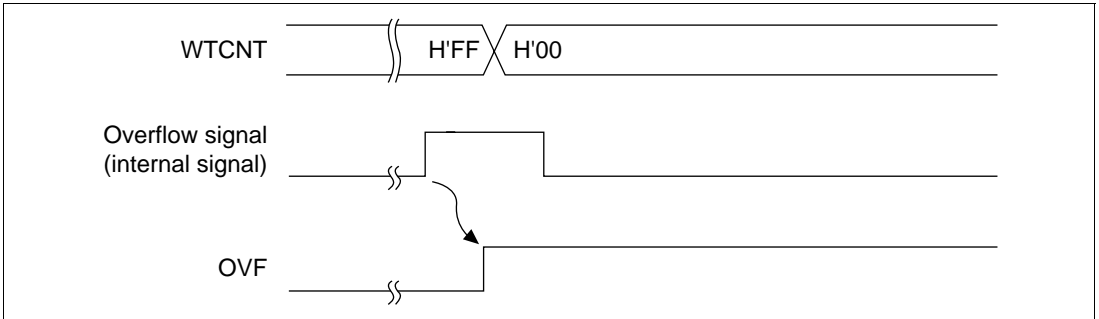

Figure 13.6 Timing of OVF Setting

13.3.5 Timing of Watchdog Timer Overflow Flag (WOVF) Setting

When WTCNT overflows the WOVF flag in RSTCSR is set to 1 and a $\overline{\text{WDTOVF}}$ signal is output. When the RSTE bit is set to 1, WTCNT overflow enables an internal reset signal to be generated for the entire chip (figure 13.7).

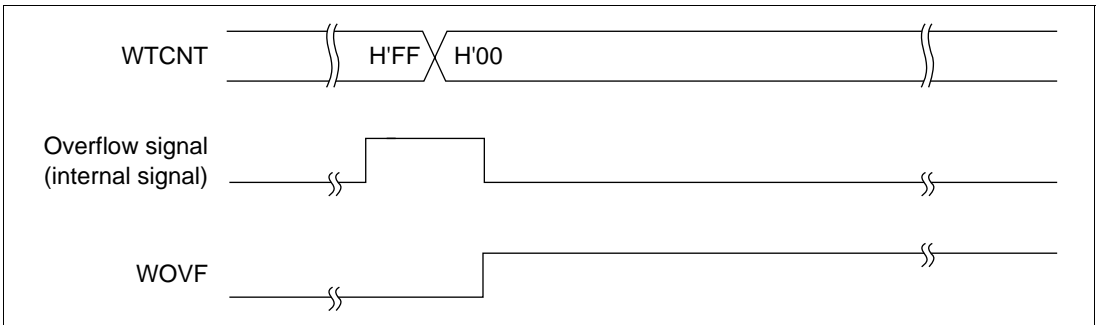

Figure 13.7 Timing of WOVF Setting

13.4 Usage Notes

13.4.1 Contention between WTCNT Write and Increment

If a count-up pulse is generated at the timing shown in figure 13.8 during a watchdog timer counter (WTCNT) write cycle, the write takes priority and the timer counter is not incremented (figure 13.8).

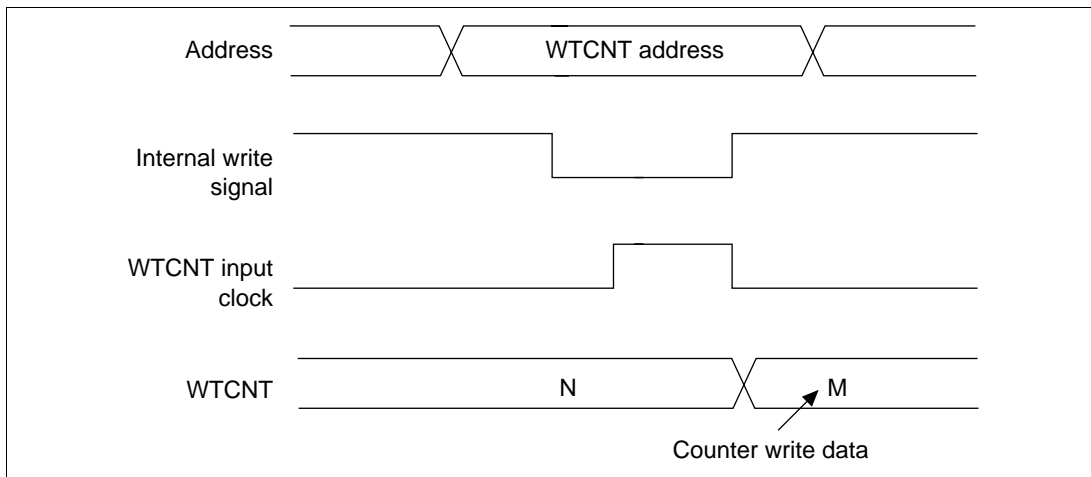

Figure 13.8 Contention between WTCNT Write and Increment

13.4.2 Changing CKS2 to CKS0 Bit Values

If the values of bits CKS2 to CKS0 are altered while the WDT is running, the count may increment incorrectly. Always stop the watchdog timer (by clearing the TME bit to 0) before changing the values of bits CKS2 to CKS0.

13.4.3 Switching between Watchdog Timer Mode and Interval Timer Mode

The WDT may not operate correctly if it is switched between watchdog timer mode and interval timer mode while it is running.

To ensure correct operation, always stop the watchdog timer (by clearing the TME bit to 0) before switching between watchdog timer mode and interval timer mode.

13.4.4 System Reset with $\overline{\text{WDTOVF}}$

If a $\overline{\text{WDTOVF}}$ signal is input to the $\overline{\text{RES}}$ pin, the device cannot initialize correctly. Avoid logical input of the $\overline{\text{WDTOVF}}$ output signal to the $\overline{\text{RES}}$ input pin. To reset the entire system with the $\overline{\text{WDTOVF}}$ signal, use the circuit shown in figure 13.9.

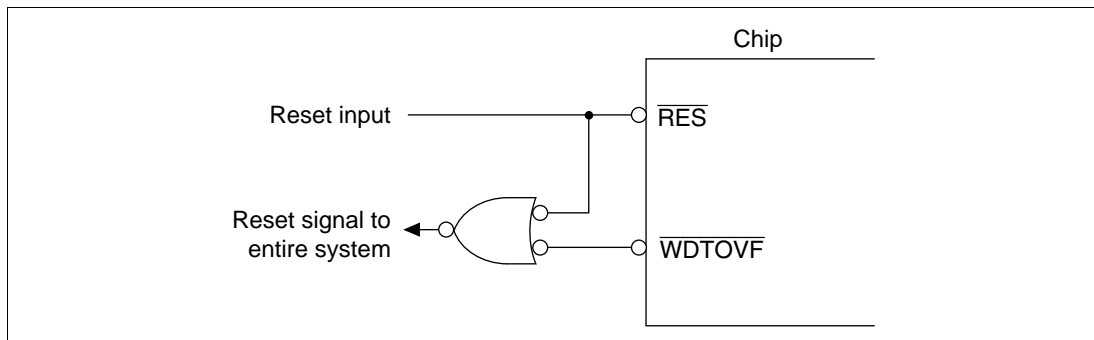

Figure 13.9 Example of Circuit for System Reset with $\overline{\text{WDTOVF}}$ Signal

13.4.5 Internal Reset in Watchdog Timer Mode

If the RSTE bit is cleared to 0 in watchdog timer mode, the chip will not reset internally when a WTCNT overflow occurs, but WTCNT and WTCSR in the WDT will reset.

When using sleep mode, do not use internal reset. Instead, use the $\overline{\text{RES}}$ pin for resetting. (See section 13.4.4, System Reset with $\overline{\text{WDTOVF}}$.)

Internal reset can be used only when sleep mode is not used.

Section 14 Serial Communication Interface with FIFO (SCIF)

14.1 Overview

The SH7616 is equipped with a two-channel serial communication interface with built-in FIFO buffers (SCIF: SCI with FIFO). The SCIF can handle both asynchronous and synchronous serial communication. A function is also provided for serial communication between processors (multiprocessor communication function).

An on-chip Infrared Data Association (IrDA) interface based on the IrDA 1.0 system is also provided, enabling infrared communication.

Sixteen-stage FIFO registers are provided for both transmission and reception, enabling fast, efficient, and continuous communication.

14.1.1 Features

The SCIF has the following features:

- Choice of synchronous or asynchronous serial communication mode
 - Asynchronous mode

Serial data communication is executed using an asynchronous system in which synchronization is achieved character by character. Serial data communication can be carried out with standard asynchronous communication chips such as a Universal Asynchronous Receiver/Transmitter (UART) or Asynchronous Communication Interface Adapter (ACIA). A multiprocessor communication function is also provided that enables serial data communication with a number of processors.

There is a choice of 12 serial data communication formats.

- Data length: 7 or 8 bits
- Stop bit length: 1 or 2 bits
- Parity: Even/odd/none
- Multiprocessor bit: 1 or 0
- Receive error detection: Parity, overrun, and framing errors
- Automatic break detection

— Synchronous mode

Serial data communication is synchronized with a clock. Serial data communication can be carried out with other chips that have a synchronous communication function.

There is a single serial data communication format.

- Data length: 8 bits
- Receive error detection: Overrun errors
- IrDA 1.0 compliance
- Full-duplex communication capability

The transmitter and receiver are mutually independent, enabling transmission and reception to be executed simultaneously. In addition, the transmitter and receiver both have a 16-stage FIFO buffer structure, enabling continuous serial data transmission and reception. (However, IrDA communication is carried out in half-duplex mode.)
- Built-in baud rate generator allows a choice of bit rates.
- Choice of transmit/receive clock source: internal clock from baud rate generator or external clock from SCK pin
- Four interrupt sources

There are four interrupt sources—transmit-FIFO-data-empty, break, receive-FIFO-data-full, and receive-error—that can issue requests independently. The transmit-FIFO-data-empty and receive-FIFO-data-full interrupts can activate the on-chip DMAC to execute data transfer.
- When not in use, the SCIF can be stopped by halting its clock supply to reduce power consumption.
- Choice of LSB-first or MSB-first mode
- In asynchronous mode, operation can be selected on a base clock of 4, 8, or 16 times the bit rate.
- Built-in modem control functions ($\overline{\text{RTS}}$ and $\overline{\text{CTS}}$)

14.1.2 Block Diagrams

A block diagram of the SCIF is shown in figure 14.1, and a diagram of the IrDA block in figure 14.2.

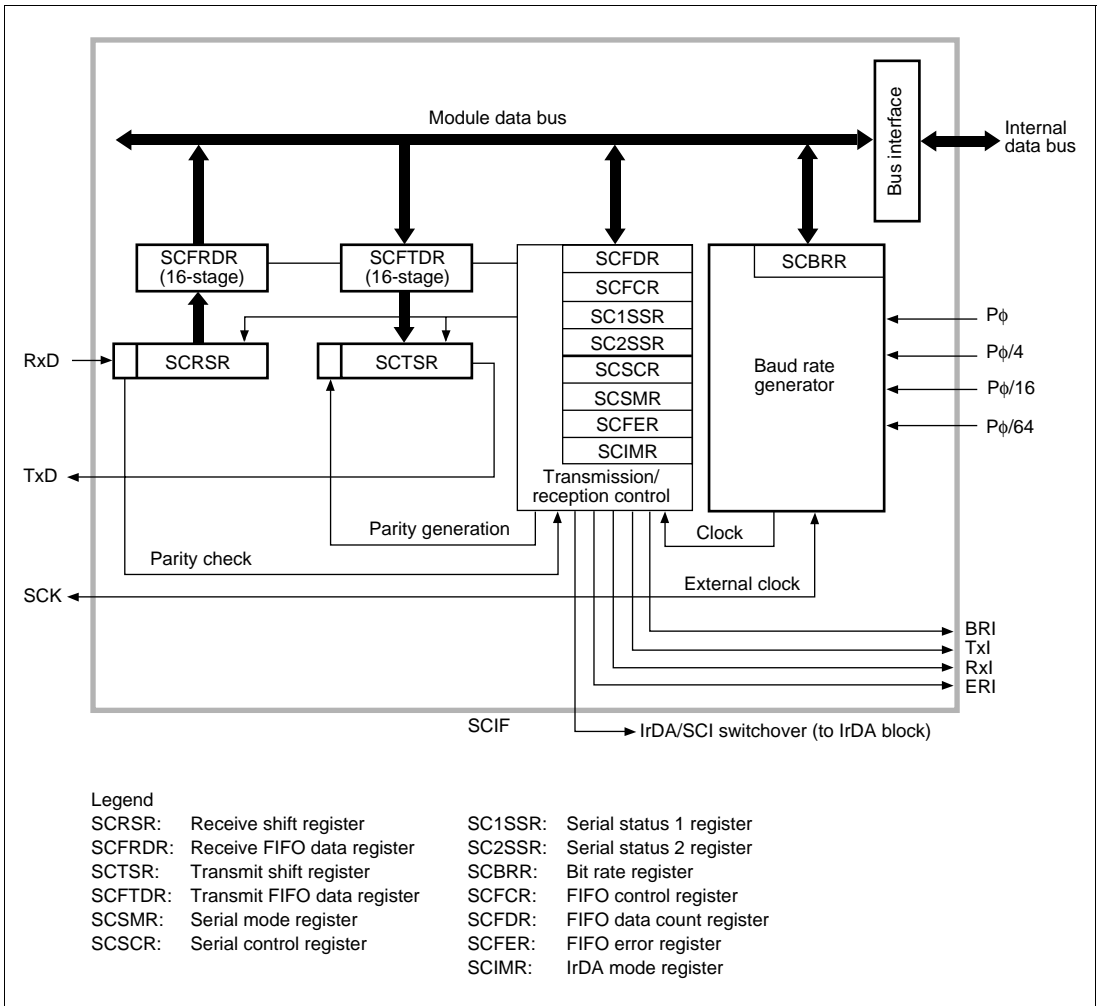

Figure 14.1 Block Diagram of SCIF

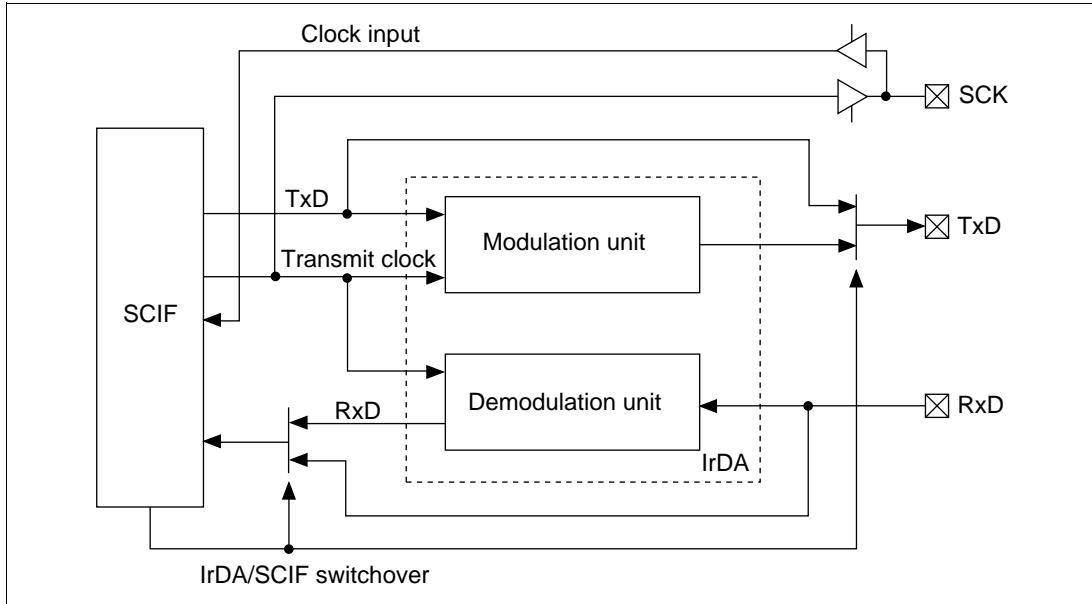

Figure 14.2 Diagram of IrDA Block

14.1.3 Pin Configuration

The SCIF has the serial pins shown in table 14.1.

Table 14.1 SCIF Pins

Channel	Name	Abbreviation	I/O	Function
1	Serial clock pin	SCK1	Input/ output	Clock input/output
	Receive data pin	RxD1	Input	Receive data input
	Transmit data pin	TxD1	Output	Transmit data output
	Transmit request pin	$\overline{\text{RTS}}$	Output	Transmit request
	Transmit enable pin	$\overline{\text{CTS}}$	Input	Transmit enable
2	Serial clock pin	SCK2	Input/ output	Clock input/output
	Receive data pin	RxD2	Input	Receive data input
	Transmit data pin	TxD2	Output	Transmit data output

14.1.4 Register Configuration

The SCIF has the internal registers shown in table 14.2. These registers are used to specify asynchronous mode/synchronous mode and the IrDA communication mode, the data format and the bit rate, and to perform transmitter/receiver control.

Table 14.2 SCIF Registers

Channel	Name	Abbreviation	R/W	Initial Value	Address	Access Size
1	Serial mode register	SCSMR1	R/W	H'00	H'FFFFFFC0	8
	Bit rate register	SCBRR1	R/W	H'FF	H'FFFFFFC2	8
	Serial control register	SCSCR1	R/W	H'00	H'FFFFFFC4	8
	Transmit FIFO data register	SCFTDR1	W	—	H'FFFFFFC6	8
	Serial status 1 register	SC1SSR1	R/(W)*	H'0060	H'FFFFFFC8	16
	Serial status 2 register	SC2SSR1	R/(W)*	H'20	H'FFFFFFCA	8
	Receive FIFO data register	SCFRDR1	R	Undefined	H'FFFFFFCC	8
	FIFO control register	SCFCR1	R/W	H'00	H'FFFFFFCE	8
	FIFO data count register	SCFDR1	R	H'0000	H'FFFFFFD0	16
	FIFO error register	SCFER1	R	H'0000	H'FFFFFFD2	16
	IrDA mode register	SCIFMR1	R/W	H'00	H'FFFFFFD4	8
2	Serial mode register	SCSMR2	R/W	H'00	H'FFFFFFE0	8
	Bit rate register	SCBRR2	R/W	H'FF	H'FFFFFFE2	8
	Serial control register	SCSCR2	R/W	H'00	H'FFFFFFE4	8
	Transmit FIFO data register	SCFTDR2	W	—	H'FFFFFFE6	8
	Serial status 1 register	SC1SSR2	R/(W)*	H'0060	H'FFFFFFE8	16
	Serial status 2 register	SC2SSR2	R/(W)*	H'20	H'FFFFFFEA	8
	Receive FIFO data register	SCFRDR2	R	Undefined	H'FFFFFFEC	8
	FIFO control register	SCFCR2	R/W	H'00	H'FFFFFFEE	8
	FIFO data count register	SCFDR2	R	H'0000	H'FFFFFFF0	16
	FIFO error register	SCFER2	R	H'0000	H'FFFFFFF2	16
	IrDA mode register	SCIMR2	R/W	H'00	H'FFFFFFF4	8

Note: *Only 0 can be written, to clear flags. Use byte access on registers with an access size of 8, and word access on registers with an access size of 16.

14.2 Register Descriptions

With the exception of the IrDA mode register (SCIMR) and bits 6 to 3 (ICK3 to ICK0) of the serial mode register (SCSMR), IrDA communication mode settings are the same as for asynchronous mode.

14.2.1 Receive Shift Register (SCRSR)

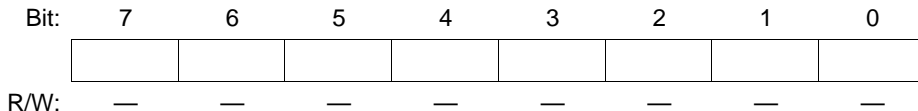

The receive shift register (SCRSR) is the register used to receive serial data.

The SCIF sets serial data input from the RxD pin in SCRSR in the order received, starting with the LSB (bit 0) or MSB (bit 7), and converts it to parallel data. When one byte of data has been received, it is transferred to the receive FIFO data register (SCFRDR) automatically.

SCRSR cannot be read or written to directly.

14.2.2 Receive FIFO Data Register (SCFRDR)

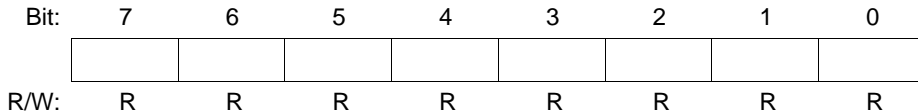

The receive FIFO data register (SCFRDR) is a 16-stage FIFO register (8 bits per stage) that stores received serial data.

When the SCIF has received one byte of serial data, it transfers the received data from SCRSR to SCFRDR where it is stored, and completes the receive operation. SCRSR is then enabled for reception, and consecutive receive operations can be performed until the receive FIFO data register is full (16 data bytes).

SCFRDR is a read-only register, and cannot be written to.

If a read is performed when there is no receive data in the receive FIFO data register, an undefined value will be returned. When the receive FIFO data register is full of receive data, subsequent serial data is lost.

14.2.3 Transmit Shift Register (SCTSR)

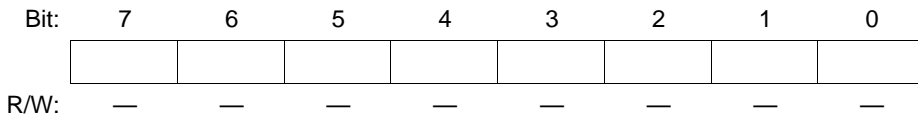

The transmit shift register (SCTSR) is the register used to transmit serial data.

To perform serial data transmission, the SCIF first transfers transmit data from SCFTDR to SCTSR, then sends the data to the TxD pin starting with the LSB (bit 0) or MSB (bit 7).

When transmission of one byte is completed, the next transmit data is transferred from SCFTDR to SCTSR, and transmission started, automatically.

SCTSR cannot be read or written to directly.

14.2.4 Transmit FIFO Data Register (SCFTDR)

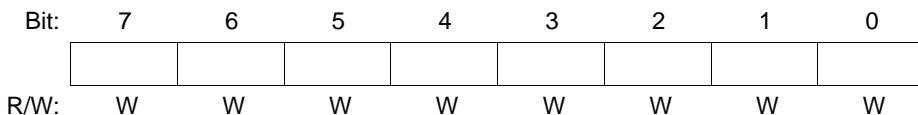

The transmit FIFO data register (SCFTDR) is a 16-stage FIFO register (8 bits per stage) that stores data for serial transmission.

When the SCIF detects that SCTSR is empty, it transfers the transmit data written in SCFTDR to SCTSR and starts serial transmission. Serial transmission is performed continuously until there is no transmit data left in SCFTDR.

SCFTDR is a write-only register, and cannot be read.

The next data cannot be written when SCFTDR is filled with 16 bytes of transmit data. Data written in this case is ignored.

14.2.5 Serial Mode Register (SCSMR)

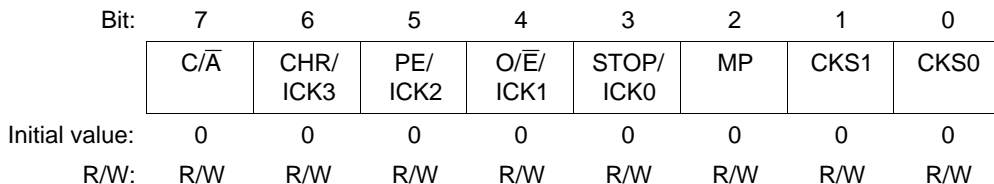

The serial mode register (SCSMR) is an 8-bit register used to set the SCIF's serial communication format and select the baud rate generator clock source. In IrDA communication mode, it is used to select the output pulse width.

SCSMR can be read or written to by the CPU at all times.

SCSMR is initialized to H'00 by a reset, by the module standby function, and in standby mode.

Bit 7—Communication Mode (C/\bar{A}): Selects asynchronous mode or synchronous mode as the SCIF operating mode. In IrDA communication mode, this bit must be cleared to 0.

Bit 7: C/\bar{A}	Description	
0	Asynchronous mode	(Initial value)
1	Synchronous mode	

Bit 6—Character Length (CHR)/IrDA Clock Select 3 (ICK3): Selects 7 or 8 bits as the data length in asynchronous mode. In synchronous mode, a fixed data length of 8 bits is used regardless of the CHR setting.

Bit 6: CHR	Description	
0	8-bit data	(Initial value)
1	7-bit data*	

Note: * When 7-bit data is selected, the MSB (bit 7) of the transmit FIFO data register (SCFTDR) is not transmitted.

In IrDA communication mode, bit 6 is the IrDA clock select 3 (ICK3) bit, enabling appropriate clock pulses to be generated according to its setting. See Pulse Width Selection, in section 14.3.6, Operation in IrDA Mode, for details.

Bit 5—Parity Enable (PE)/IrDA Clock Select 2 (ICK2): In asynchronous mode, selects whether or not parity bit addition is performed in transmission, and parity bit checking in reception. In synchronous mode, parity bit addition and checking is not performed, regardless of the PE bit setting.

Bit 5: PE	Description	
0	Parity bit addition and checking disabled	(Initial value)
1	Parity bit addition and checking enabled*	

Note: * When the PE bit is set to 1, the parity (even or odd) specified by the O/\bar{E} bit is added to transmit data before transmission. In reception, the parity bit is checked for the parity (even or odd) specified by the O/\bar{E} bit.

In IrDA communication mode, bit 5 is the IrDA clock select 2 (ICK2) bit, enabling appropriate clock pulses to be generated according to its setting. See Pulse Width Selection, in section 14.3.6, Operation in IrDA Mode, for details.

Bit 4—Parity Mode (O/\bar{E})/IrDA Clock Select 1 (ICK1): Selects either even or odd parity for use in parity addition and checking. The O/\bar{E} bit setting is only valid when the PE bit is set to 1, enabling parity bit addition and checking, in asynchronous mode. The O/\bar{E} bit setting is invalid in synchronous mode, and when parity addition and checking is disabled in asynchronous mode.

Bit 4: O/\bar{E}	Description
0	Even parity* ¹ (Initial value)
1	Odd parity* ²

Notes: *1 When even parity is set, parity bit addition is performed in transmission so that the total number of 1-bits in the transmit character plus the parity bit is even. In reception, a check is performed to see if the total number of 1-bits in the receive character plus the parity bit is even.

*2 When odd parity is set, parity bit addition is performed in transmission so that the total number of 1-bits in the transmit character plus the parity bit is odd. In reception, a check is performed to see if the total number of 1-bits in the receive character plus the parity bit is odd.

In IrDA communication mode, bit 4 is the IrDA clock select 1 (ICK1) bit, enabling appropriate clock pulses to be generated according to its setting. See Pulse Width Selection, in section 14.3.6, Operation in IrDA Mode, for details.

Bit 3—Stop Bit Length (STOP)/IrDA Clock Select 0 (ICK0): Selects 1 or 2 bits as the stop bit length in asynchronous mode. The STOP bit setting is only valid in asynchronous mode. When synchronous mode is set, the STOP bit setting is invalid since stop bits are not added.

Bit 3: STOP	Description
0	1 stop bit* ¹ (Initial value)
1	2 stop bits* ²

Notes: *1 In transmission, a single 1-bit (stop bit) is added to the end of a transmit character before it is sent.

*2 In transmission, two 1-bits (stop bits) are added to the end of a transmit character before it is sent.

In reception, only the first stop bit is checked, regardless of the STOP bit setting. If the second stop bit is 1, it is treated as a stop bit; if it is 0, it is treated as the start bit of the next transmit character.

In IrDA communication mode, bit 3 is the IrDA clock select 0 (ICK0) bit, enabling appropriate clock pulses to be generated according to its setting. See Pulse Width Selection, in section 14.3.6, Operation in IrDA Mode, for details.

Bit 2—Multiprocessor Mode (MP): Selects a multiprocessor format. When a multiprocessor format is selected, the PE bit and O/\bar{E} bit parity settings are invalid. The MP bit setting is only valid in asynchronous mode; it is invalid in synchronous mode and IrDA mode.

For details of the multiprocessor communication function, see section 14.3.3, Multiprocessor Communication Function.

Bit 2: MP	Description	
0	Multiprocessor function disabled	(Initial value)
1	Multiprocessor format selected	

Bits 1 and 0—Clock Select 1 and 0 (CKS1, CKS0): These bits select the clock source for the built-in baud rate generator. The clock source can be selected from $P\phi$, $P\phi/4$, $P\phi/16$, and $P\phi/64$, according to the setting of bits CKS1 and CKS0.

For the relationship between the clock source, the bit rate register setting, and the baud rate, see section 14.2.9, Bit Rate Register (SCBRR).

Bit 1: CKS1	Bit 0: CKS0	Description	
0	0	$P\phi$ clock	(Initial value)
	1	$P\phi/4$ clock	
1	0	$P\phi/16$ clock	
	1	$P\phi/64$ clock	

Note: $P\phi$ = peripheral clock

14.2.6 Serial Control Register (SCSCR)

Bit:	7	6	5	4	3	2	1	0
	TIE	RIE	TE	RE	MPIE	—	CKE1	CKE0
Initial value:	0	0	0	0	0	0	0	0
R/W:	R/W	R/W	R/W	R/W	R/W	R	R/W	R/W

The serial control register (SCSCR) performs enabling or disabling of SCIF transmit/receive operations, serial clock output in asynchronous mode, and interrupt requests, and selection of the transmit/receive clock source.

SCSCR can be read or written to by the CPU at all times.

SCSCR is initialized to H'00 by a reset, by the module standby function, and in standby mode.

Bit 7—Transmit Interrupt Enable (TIE): Enables or disables transmit-FIFO-data-empty interrupt (TXI) request generation when, after serial transmit data is transferred from the transmit FIFO data register (SCFTDR) to the transmit shift register (SCTSR), the number of data bytes in SCFTDR falls to or below the transmit trigger set number, and the TDFE flag is set to 1 in the serial status 1 register (SC1SSR).

Bit 7: TIE	Description
0	Transmit-FIFO-data-empty interrupt (TXI) request disabled* (Initial value)
1	Transmit-FIFO-data-empty interrupt (TXI) request enabled

Note: * TXI interrupt requests can be cleared by writing transmit data exceeding the transmit trigger set number to SCFTDR, reading 1 from the TDFE flag, then clearing it to 0, or by clearing the TIE bit to 0. When transmit data is written to SCFTDR using the on-chip DMAC, the TDFE flag is cleared automatically.

Bit 6—Receive Interrupt Enable (RIE): Enables or disables generation of a receive-FIFO-data-full interrupt (RXI) request and receive-error interrupt (ERI) request when, after serial receive data is transferred from the receive shift register (SCRSR) to the receive FIFO data register (SCFRDR), the number of data bytes in SCFRDR reaches or exceeds the receive trigger set number, and the RDF flag is set to 1 in SC1SSR.

Bit 6: RIE	Description
0	Receive-FIFO-data-full interrupt (RXI) request, receive-error interrupt (ERI) request, and break interrupt (BRI) request disabled* (Initial value)
1	Receive-FIFO-data-full interrupt (RXI) request, receive-error interrupt (ERI) request, and break interrupt (BRI) request enabled

Note: * RXI, ERI, and BRI interrupt requests can be cleared by reading 1 from the RDF or DR flag, the FER, PER, ORER, or ER flag, or the BRK flag, then clearing the flag to 0, or by clearing the RIE bit to 0. With the RDF flag, read receive data from SCFRDR until the number of receive data bytes is less than the receive trigger set number, then read 1 from the RDF flag and clear it to 0.

Bit 5—Transmit Enable (TE): Enables or disables the start of serial transmission by the SCIF.

Bit 5: TE	Description
0	Transmission disabled* ¹ (Initial value)
1	Transmission enabled* ²

Notes: *¹ The TDRE flag in SC1SSR is fixed at 1.

*² Serial transmission is started when transmit data is written to SCFTDR in this state. Serial mode register (SCSMR) and FIFO control register (SCFCR) settings must be made, the transmission format decided, and the transmit FIFO reset, before the TE bit is set to 1.

Bit 4—Receive Enable (RE): Enables or disables the start of serial reception by the SCIF.

Bit 4: RE	Description
0	Reception disabled* ¹ (Initial value)
1	Reception enabled* ²

Notes: *1 Clearing the RE bit to 0 does not affect the RDF, DR, FER, PER, ORER, ER, and BRK flags, which retain their states.

*2 Serial reception is started in this state when a start bit is detected in asynchronous mode or serial clock input is detected in synchronous mode.

SCSMR settings must be made to decide the reception format before setting the RE bit to 1.

Bit 3—Multiprocessor Interrupt Enable (MPIE): Enables or disables multiprocessor interrupts. The MPIE bit setting is only valid in asynchronous mode when the MP bit in SCSMR is set to 1.

The MPIE bit setting is invalid in synchronous mode and IrDA mode, and when the MP bit is 0.

Bit 3: MPIE	Description
0	Multiprocessor interrupts disabled (normal reception performed) (Initial value) [Clearing conditions] <ul style="list-style-type: none">• When the MPIE bit is cleared to 0• When data with MPB = 1 is received
1	Multiprocessor interrupts enabled* Receive interrupt (RXI) requests, receive-error interrupt (ERI) requests, and setting of the RDF and FER in SC1SSR and ORER in SC2SSR are disabled until data with the multiprocessor bit set to 1 is received.

Note: * Receive data transfer from SCRSR to SCFRDR, receive error detection, and setting of the RDF and FER in SC1SSR and ORER flags in SC2SSR, is not performed. When receive data with MPB = 1 is received, the MPB flag in SC2SSR is set to 1, the MPIE bit is cleared to 0 automatically, and generation of RXI and ERI (when the RIE bit in SCSCR is set to 1) and FER and ORER flag setting is enabled.

Bit 2—Reserved: This bit is always read as 0. The write value should always be 0.

Bits 1 and 0—Clock Enable 1 and 0 (CKE1, CKE0): These bits are used to select the SCIF clock source and enable or disable clock output from the SCK pin. The combination of the CKE1 and CKE0 bits determines whether the SCK pin functions as the serial clock output pin or the serial clock input pin. The function of the SCK pin should be selected with the pin function controller (PFC).

The setting of the CKE0 bit, however, is only valid for internal clock operation (CKE1 = 0) in asynchronous mode. The CKE0 bit setting is invalid in synchronous mode and in the case of external clock operation (CKE1 = 1). The CKE1 and CKE0 bits must be set before determining the SCIF's operating mode with SCSMR.

For details of clock source selection, see table 14.9 in section 14.3, Operation.

Bit 1: CKE1	Bit 0: CKE0	Description	
0	0	Asynchronous mode	Internal clock/SCK pin functions as input pin (input signal ignored)* ¹
		Synchronous mode	Internal clock/SCK pin functions as serial clock output* ¹
	1	Asynchronous mode	Internal clock/SCK pin functions as clock output* ²
		Synchronous mode	Internal clock/SCK pin functions as serial clock output
1	* ⁴	Asynchronous mode	External clock/SCK pin functions as clock input* ³
		Synchronous mode	External clock/SCK pin functions as serial clock input

Notes: *1 Initial value

*2 Outputs a clock with a frequency of 16/8/4 times the bit rate.

*3 Inputs a clock with a frequency of 16/8/4 times the bit rate.

*4 Don't care

14.2.7 Serial Status 1 Register (SC1SSR)

Bit:	15	14	13	12	11	10	9	8
	PER3	PER2	PER1	PER0	FER3	FER2	FER1	FER0
Initial value:	0	0	0	0	0	0	0	0
R/W:	R	R	R	R	R	R	R	R

Bit:	7	6	5	4	3	2	1	0
	ER	TEND	TDFE	BRK	FER	PER	RDF	DR
Initial value:	0	1	1	0	0	0	0	0
R/W:	R/(W)*	R	R/(W)*	R/(W)*	R	R	R/(W)*	R/(W)*

Note: * Only 0 can be written, to clear the flag.

The serial status 1 register (SC1SSR) is a 16-bit register in which the lower 8 bits consist of status flags that indicate the operating status of the SCIF, and the upper 8 bits indicate the number of receive errors in the data in the receive FIFO register.

SC1SSR can be read or written to at all times. However, 1 cannot be written to the ER, TDFE, BRK, RDF, and DR status flags. Also note that in order to clear these flags to 0, they must first be read as 1. The TEND, FER, and PER flags are read-only and cannot be modified.

SC1SSR is initialized to H'0084 by a reset, by the module standby function, and in standby mode.

Bits 15 to 12—Parity Error Count 3 to 0 (PER3 to PER0): These bits indicate the number of data bytes in which a parity error occurred in the receive data in the receive FIFO data register.

These bits are cleared by reading all the receive data in the receive FIFO data register, or by setting the RFRST bit to 1 in SCFCR and resetting the receive FIFO data register to the empty state.

Bits 11 to 8—Framing Error Count 3 to 0 (FER3 to FER0): These bits indicate the number of data bytes in which a framing error occurred in the receive data in the receive FIFO data register.

These bits are cleared by reading all the receive data in the receive FIFO data register, or by setting the RFRST bit to 1 in SCFCR and resetting the receive FIFO data register to the empty state.

Bit 7—Receive Error (ER)

Bit 7: ER	Description
0	Reception in progress, or reception has ended normally* ¹ (Initial value) [Clearing conditions] <ul style="list-style-type: none">• In a reset or in standby mode• When 0 is written to ER after reading ER = 1
1	A framing error, parity error, or overrun error occurred during reception [Setting conditions] <ul style="list-style-type: none">• When the SCIF checks whether the stop bit at the end of the receive data is 1 when reception ends, and the stop bit is 0*²• When, in reception, the number of 1-bits in the receive data plus the parity bit does not match the parity setting (even or odd) specified by the O/\bar{E} bit in the serial mode register (SCSMR)• When the next serial receive operation is completed while there are 16 receive data bytes in SCFRDR

Notes: *¹ The ER flag is not affected and retains its previous state when the RE bit in SCSCR is cleared to 0. When a framing error or parity error occurs, the receive data is still transferred to SCFRDR, and reception is then halted or continued according to the setting of the EI bit. When an overrun error occurs, the receive data is not transferred to SCFRDR and reception cannot be continued.

*² In 2-stop-bit mode, only the first stop bit is checked for a value of 1; the second stop bit is not checked.

Bit 6—Transmit End (TEND): Indicates that there is no valid data in SCFTDR when the last bit of the transmit character is sent, and transmission has been ended.

Bit 6: TEND	Description
0	Transmission is in progress [Clearing condition] When data is written to SCFTDR while TE = 1
1	Transmission has been ended (Initial value) [Setting conditions] <ul style="list-style-type: none">• In a reset or in standby mode• When the TE bit in SCSCR is 0• When there is no transmit data in SCFTDR on transmission of the last bit of a 1-byte serial transmit character

Bit 5—Transmit Data FIFO Empty (TDFE): Indicates that data has been transferred from the transmit FIFO data register (SCFTDR) to the transmit shift register (SCTSR), the number of data bytes in SCFTDR has fallen to or below the transmit trigger data number set by bits TTRG1 and TTRG0 in the FIFO control register (SCFCR), and transmit data can be written to SCFTDR.

Bit 5: TDFE	Description
0	<p>A number of transmit data bytes exceeding the transmit trigger set number have been written to SCFTDR</p> <p>[Clearing conditions]</p> <ul style="list-style-type: none"> When transmit data exceeding the transmit trigger set number is written to SCFTDR, and 0 is written to TDFE after reading TDFE = 1 When transmit data exceeding the transmit trigger set number is written to SCFTDR by the on-chip DMAC
1	<p>The number of transmit data bytes in SCFTDR does not exceed the transmit trigger set number (Initial value)</p> <p>[Setting conditions]</p> <ul style="list-style-type: none"> In a reset or in standby mode When the number of SCFTDR transmit data bytes falls to or below the transmit trigger set number as the result of a transmit operation*

Note: * As SCFTDR is a 16-byte FIFO register, the maximum number of bytes that can be written when TDFE = 0 is $\{16 - (\text{transmit trigger set number})\}$. Data written in excess of this will be ignored. The number of data bytes in SCFTDR is indicated by the upper 8 bits of SCFDR.

Bit 4—Break Detect (BRK): Indicates that a receive data break signal has been detected.

Bit 4: BRK	Description
0	<p>A break signal has not been received (Initial value)</p> <p>[Clearing conditions]</p> <ul style="list-style-type: none"> In a reset or in standby mode When 0 is written to BRK after reading BRK = 1
1	<p>A break signal has been received</p> <p>[Setting condition]</p> <p>When data with a framing error is received, and a framing error also occurs in the next receive data (all space "0")</p>

Note: When a break is detected, transfer to SCFRDR of the receive data (H'00) following detection is halted. When the break ends and the receive signal returns to mark "1", receive data transfer is resumed.

Bit 3—Framing Error (FER): Indicates a framing error in the data read from the receive FIFO data register (SCFRDR).

Bit 3: FER	Description
0	There is no framing error in the receive data read from SCFRDR (Initial value) [Clearing conditions] <ul style="list-style-type: none">• In a reset or in standby mode• When there is no framing error in SCFRDR read data
1	There is a framing error in the receive data read from SCFRDR [Setting condition] When there is a framing error in SCFRDR read data

Bit 2—Parity Error (PER): In asynchronous mode, indicates a parity error in the data read from the receive FIFO data register (SCFRDR).

Bit 2: PER	Description
0	There is no parity error in the receive data read from SCFRDR (Initial value) [Clearing conditions] <ul style="list-style-type: none">• In a reset or in standby mode• When there is no parity error in SCFRDR read data
1	There is a parity error in the receive data read from SCFRDR [Setting condition] When there is a parity error in SCFRDR read data

Bit 1—Receive Data Register Full (RDF): Indicates that the received data has been transferred to the receive FIFO data register (SCFRDR), and the number of receive data bytes in SCFRDR is equal to or greater than the receive trigger number set by bits RTRG1 and RTRG0 in the FIFO control register (SCFCR).

Bit 1: RDF	Description
0	<p>The number of receive data bytes in SCFRDR is less than the receive trigger set number (Initial value)</p> <p>[Clearing conditions]</p> <ul style="list-style-type: none"> • In a reset or in standby mode • When SCFRDR is read until the number of receive data bytes in SCFRDR falls below the receive trigger set number, and 0 is written to RDF after reading RDF = 1 • When SCFRDR is read by the on-chip DMAC until the number of receive data bytes in SCFRDR falls below the receive trigger set number
1	<p>The number of receive data bytes in SCFRDR is equal to or greater than the receive trigger set number</p> <p>[Setting condition]</p> <p>When SCFRDR contains at least the receive trigger set number of receive data bytes</p>

Note: SCFRDR is a 16-byte FIFO register. When RDF = 1, at least the receive trigger set number of data bytes can be read. If all the data in SCFRDR is read and another read is performed, the data value will be undefined. The number of receive data bytes in SCFRDR is indicated by the lower 8 bits of SCFRDR.

Bit 0—Receive Data Ready (DR): Indicates that there are fewer than the receive trigger set number of data bytes in the receive FIFO data register (SCFRDR), and no further data has arrived for at least 16 etu after the stop bit of the last data received.

Bit 0: DR	Description
0	<p>Reception is in progress or has ended normally and there is no receive data left in SCFRDR (Initial value)</p> <p>[Clearing conditions]</p> <ul style="list-style-type: none"> • In a reset or in standby mode • When 0 is written to DR after all the remaining receive data has been read*¹
1	<p>No further receive data has arrived, and SCFRDR contains fewer than the receive trigger set number of data bytes</p> <p>[Setting condition]</p> <p>When SCFRDR contains fewer than the receive trigger set number of receive data bytes, and no further data has arrived for at least 16 etu after the stop bit of the last data received*²</p>

Notes: *1 All remaining receive data should be read before clearing the DR flag.

*2 Equivalent to 1.6 frames when using an 8-bit, 1-stop-bit format.

etu: Elementary time unit = sec/bit

14.2.8 Serial Status 2 Register (SC2SSR)

Bit:	7	6	5	4	3	2	1	0
	TLM	RLM	N1	N0	MPB	MPBT	EI	ORER
Initial value:	0	0	1	0	0	0	0	0
R/W:	R/W	R/W	R/W	R/W	R	R/W	R/W	R/(W)*

Note: * Only 0 can be written, to clear the flag.

The serial status 2 register (SC2SSR) is an 8-bit register.

SC2SSR can be read or written to at all times. However, 1 cannot be written to the ORER flag. Also note that in order to clear this flag to 0, they must first be read as 1.

SC2SSR is initialized to H'20 by a reset, by the module standby function, and in standby mode.

Bit 7—Transmit LSB/MSB-First Select (TLM): Selects LSB-first or MSB-first mode in data transmission.

Bit 7: TLM	Description
0	LSB-first transmission (Initial value)
1	MSB-first transmission

Bit 6—Receive LSB/MSB-First Select (RLM): Selects LSB-first or MSB-first mode in data reception.

Bit 6: RLM	Description
0	LSB-first reception (Initial value)
1	MSB-first reception

Bits 5 and 4—Clock Bit Rate Ratio (N1, N0): These bits select the ratio of the base clock to the bit rate.

Bit 5: N1	Bit 4: N0	Description
0	0	SCIF operates on base clock of 4 times the bit rate
	1	SCIF operates on base clock of 8 times the bit rate
1	0	SCIF operates on base clock of 16 times the bit rate (Initial value)
	1	Setting prohibited

Bit 3—Multiprocessor bit (MPB): When reception is performed using a multiprocessor format in asynchronous mode, MPB stores the multiprocessor bit in the receive data.

The MPB flag is read-only and cannot be modified.

Bit 3: MPB	Description
0	Data with a 0 multiprocessor bit has been received* (Initial value)
1	Data with a 1 multiprocessor bit has been received

Note: * Retains its previous state when the RE bit is cleared to 0 while using a multiprocessor format.

Bit 2—Multiprocessor Bit Transfer (MPBT): When transmission is performed using a multiprocessor format in asynchronous mode, MPBT stores the multiprocessor bit to be added to the transmit data.

The MPBT bit setting is invalid in synchronous mode and IrDA mode, when a multiprocessor format is not used, and when the operation is not transmission.

Bit 2: MPBT	Description
0	Data with a 0 multiprocessor bit is transmitted (Initial value)
1	Data with a 1 multiprocessor bit is transmitted

Bit 1—Receive Data Error Ignore Enable (EI): Selects whether or not the receive operation is to be continued when a framing error or parity error occurs in receive data (ER = 1).

Bit 1: EI	Description
0	Receive operation is halted when framing error or parity error occurs during reception (ER = 1) (Initial value)
1	Receive operation is continued when framing error or parity error occurs during reception (ER = 1)

Note: When EI = 0, only the last data in SCFRDR is treated as data containing an error. When EI = 1, receive data is sent to SCFRDR even if it contains an error.

Bit 0—Overrun Error (ORER): Indicates that an overrun error occurred during reception, causing abnormal termination.

Bit 0: ORER	Description
0	Reception in progress, or reception has ended normally* ¹ (Initial value) [Clearing conditions] <ul style="list-style-type: none"> In a reset or in standby mode When 0 is written to ORER after reading ORER = 1
1	An overrun error occurred during reception* ² [Setting condition] When the next serial receive operation is completed while there are 16 receive data bytes in SCFRDR

Notes: *¹ The ORER flag is not affected and retains its previous state when the RE bit in SCSCR is cleared to 0.

*² The receive data prior to the overrun error is retained in SCFRDR, and the data received subsequently is lost. Serial reception cannot be continued while the ORER flag is set to 1. Also, serial transmission cannot be continued in synchronous mode.

14.2.9 Bit Rate Register (SCBRR)

Bit:	7	6	5	4	3	2	1	0
Initial value:	1	1	1	1	1	1	1	1
R/W:	R/W	R/W	R/W	R/W	R/W	R/W	R/W	R/W

The bit rate register (SCBRR) is an 8-bit register that sets the serial transmit/receive bit rate in accordance with the baud rate generator operating clock selected by bits CKS1 and CKS0 in the serial mode register (SCSMR).

SCBRR can be read or written to by the CPU at all times.

SCBRR is initialized to H'FF by a reset, by the module standby function, and in standby mode.

The SCBRR setting is found from the following equations.

Asynchronous mode:

$$N = \frac{P\phi}{64 \times 2^{2n-1} \times B} \times 10^6 - 1 \quad (\text{When operating on a base clock of 16 times the bit rate})$$

$$N = \frac{P\phi}{32 \times 2^{2n-1} \times B} \times 10^6 - 1 \quad (\text{When operating on a base clock of 8 times the bit rate})$$

$$N = \frac{P\phi}{16 \times 2^{2n-1} \times B} \times 10^6 - 1 \quad (\text{When operating on a base clock of 4 times the bit rate})$$

Synchronous mode:

$$N = \frac{P\phi}{8 \times 2^{2n-1} \times B} \times 10^6 - 1$$

Where B: Bit rate (bits/s)

N: SCBRR setting for baud rate generator ($0 \leq N \leq 255$)

Pφ: Peripheral module operating frequency (MHz)

n: Baud rate generator input clock (n = 0, 1, 2, or 3)

(See the table below for the relation between n and the clock.)

n	Clock	SCSMR Settings	
		CKS1	CKS0
0	Pφ	0	0
1	Pφ/4		1
2	Pφ/16	1	0
3	Pφ/64		1

The bit rate error in asynchronous mode is found from the following equations:

$$\text{Error (\%)} = \left\{ \frac{P\phi \times 10^6}{(N + 1) \times B \times 64 \times 2^{2n-1}} - 1 \right\} \times 100$$

(When operating on a base clock of 16 times the bit rate)

$$\text{Error (\%)} = \left\{ \frac{P\phi \times 10^6}{(N + 1) \times B \times 32 \times 2^{2n-1}} - 1 \right\} \times 100$$

(When operating on a base clock of 8 times the bit rate)

$$\text{Error (\%)} = \left\{ \frac{P\phi \times 10^6}{(N + 1) \times B \times 16 \times 2^{2n-1}} - 1 \right\} \times 100$$

(When operating on a base clock of 4 times the bit rate)

Table 14.3 shows sample SCBRR settings in asynchronous mode, and table 14.4 shows sample SCBRR settings in synchronous mode. In both tables, the values are for operation on a base clock of 16 times the bit rate.

Table 14.3 Examples of Bit Rates and SCBRR Settings in Asynchronous Mode

Bit Rate (Bits/s)	P ϕ (MHz)											
	2			2.097152			2.4576			3		
	n	N	Error (%)	n	N	Error (%)	n	N	Error (%)	n	N	Error (%)
110	1	141	0.03	1	148	-0.04	1	174	-0.26	1	212	0.03
150	1	103	0.16	1	108	0.21	1	127	0.00	1	155	0.16
300	0	207	0.16	0	217	0.21	0	255	0.00	1	77	0.16
600	0	103	0.16	0	108	0.21	0	127	0.00	0	155	0.16
1200	0	51	0.16	0	54	-0.70	0	63	0.00	0	77	0.16
2400	0	25	0.16	0	26	1.14	0	31	0.00	0	38	0.16
4800	0	12	0.16	0	13	-2.48	0	15	0.00	0	19	-2.34
9600	0	6	-6.99	0	6	-2.48	0	7	0.00	0	9	-2.34
19200	0	2	8.51	0	2	13.78	0	3	0.00	0	4	-2.34
31250	0	1	0.00	0	1	4.86	0	1	22.88	0	2	0.00
38400	0	1	-18.62	0	1	-14.67	0	1	0.00	—	—	—

Table 14.3 Examples of Bit Rates and SCBRR Settings in Asynchronous Mode (cont)

Bit Rate (Bits/s)	P ϕ (MHz)											
	3.6864			4			4.9152			5		
	n	N	Error (%)	n	N	Error (%)	n	N	Error (%)	n	N	Error (%)
110	2	64	0.70	2	70	0.03	2	86	0.31	2	88	-0.25
150	1	191	0.00	1	207	0.16	1	255	0.00	2	64	0.16
300	1	95	0.00	1	103	0.16	1	127	0.00	1	129	0.16
600	0	191	0.00	0	207	0.16	0	255	0.00	1	64	0.16
1200	0	95	0.00	0	103	0.16	0	127	0.00	0	129	0.16
2400	0	47	0.00	0	51	0.16	0	63	0.00	0	64	0.16
4800	0	23	0.00	0	25	0.16	0	31	0.00	0	32	-1.36
9600	0	11	0.00	0	12	0.16	0	15	0.00	0	15	1.73
19200	0	5	0.00	0	6	-6.99	0	7	0.00	0	7	1.73
31250	—	—	—	0	3	0.00	0	4	-1.70	0	4	0.00
38400	0	2	0.00	0	2	8.51	0	3	0.00	0	3	1.73

Bit Rate (Bits/s)	P ϕ (MHz)											
	6			6.144			7.37288			8		
	n	N	Error (%)	n	N	Error (%)	n	N	Error (%)	n	N	Error (%)
110	2	106	-0.44	2	108	0.08	2	130	-0.07	2	141	0.03
150	2	77	0.16	2	79	0.00	2	95	0.00	2	103	0.16
300	1	155	0.16	1	159	0.00	1	191	0.00	1	207	0.16
600	1	77	0.16	1	79	0.00	1	95	0.00	1	103	0.16
1200	0	155	0.16	0	159	0.00	0	191	0.00	0	207	0.16
2400	0	77	0.16	0	79	0.00	0	95	0.00	0	103	0.16
4800	0	38	0.16	0	39	0.00	0	47	0.00	0	51	0.16
9600	0	19	-2.34	0	19	0.00	0	23	0.00	0	25	0.16
19200	0	9	-2.34	0	9	0.00	0	11	0.00	0	12	0.16
31250	0	5	0.00	0	5	2.40	0	6	5.33	0	7	0.00
38400	0	4	-2.34	0	4	0.00	0	5	0.00	0	6	-6.99

Table 14.3 Examples of Bit Rates and SCBRR Settings in Asynchronous Mode (cont)

Bit Rate (Bits/s)	P ϕ (MHz)											
	9.8304			10			12			12.288		
	n	N	Error (%)	n	N	Error (%)	n	N	Error (%)	n	N	Error (%)
110	2	174	-0.26	2	177	-0.25	2	212	0.03	2	217	0.08
150	2	127	0.00	2	129	0.16	2	155	0.16	2	159	0.00
300	1	255	0.00	2	64	0.16	2	77	0.16	2	79	0.00
600	1	127	0.00	1	129	0.16	1	155	0.16	1	159	0.00
1200	0	255	0.00	1	64	0.16	1	77	0.16	1	79	0.00
2400	0	127	0.00	0	129	0.16	0	155	0.16	0	159	0.00
4800	0	63	0.00	0	64	0.16	0	77	0.16	0	79	0.00
9600	0	31	0.00	0	32	-1.36	0	38	0.16	0	39	0.00
19200	0	15	0.00	0	15	1.73	0	19	-2.34	0	19	0.00
31250	0	9	-1.70	0	9	0.00	0	11	0.00	0	11	2.40
38400	0	7	0.00	0	7	1.73	0	9	-2.34	0	9	0.00

Bit Rate (Bits/s)	P ϕ (MHz)								
	14.7456			16			30		
	n	N	Error (%)	n	N	Error (%)	n	N	Error (%)
110	3	64	0.70	3	70	0.03	3	132	0.13
150	2	191	0.00	2	207	0.16	3	97	-0.35
300	2	95	0.00	2	103	0.16	2	194	0.16
600	1	191	0.00	1	207	0.16	2	97	-0.35
1200	1	95	0.00	1	103	0.16	1	194	0.16
2400	0	191	0.00	0	207	0.16	1	97	-0.35
4800	0	95	0.00	0	103	0.16	0	194	0.16
9600	0	47	0.00	0	51	0.16	0	97	-0.35
19200	0	23	0.00	0	25	0.16	0	48	-0.35
31250	0	14	-1.70	0	15	0.00	0	29	0.00
38400	0	11	0.00	0	12	0.16	0	23	1.73

Table 14.4 Examples of Bit Rates and SCBRR Settings in Synchronous Mode

Bit Rate (Bits/s)	P ϕ (MHz)							
	4		8		16		32	
	n	N	n	N	n	N	n	N
110	—	—	—	—	—	—	—	—
250	2	249	3	124	3	249	—	—
500	2	124	2	249	3	124	3	249
1 k	1	249	2	124	2	249	3	124
2.5 k	1	99	1	199	2	99	2	199
5 k	0	199	1	99	1	199	2	99
10 k	0	99	0	199	1	99	1	199
25 k	0	39	0	79	0	159	1	79
50 k	0	19	0	39	0	79	0	159
100 k	0	9	0	19	0	39	0	79
250 k	0	3	0	7	0	15	0	31
500 k	0	1	0	3	0	7	0	15
1 M	0	0*	0	1	0	3	0	7
2 M			0	0*	0	1	0	3

Note: As far as possible, the setting should be made so that the error is within 1%.

Legend

Blank: No setting is available.

—: A setting is available but error occurs.

* Continuous transmission/reception is not possible.

Table 14.5 shows the maximum bit rate for various frequencies in asynchronous mode when using the baud rate generator. Tables 14.6 and 14.7 show the maximum bit rates when using external clock input.

Table 14.5 Maximum Bit Rate for Various Frequencies with Baud Rate Generator (Asynchronous Mode)

P ϕ (MHz)	Maximum Bit Rate (Bits/s)	Settings	
		n	N
2	62500	0	0
2.097152	65536	0	0
2.4576	76800	0	0
3	93750	0	0
3.6864	115200	0	0
4	125000	0	0
4.9152	153600	0	0
8	250000	0	0
9.8304	307200	0	0
12	375000	0	0
14.7456	460800	0	0
16	500000	0	0
19.66080	614400	0	0
20	625000	0	0
24	750000	0	0
24.57600	768000	0	0
28	896875	0	0
30	937500	0	0

Table 14.6 Maximum Bit Rate with External Clock Input (Asynchronous Mode)

Pϕ (MHz)	External Input Clock (MHz)	Maximum Bit Rate (Bits/s)
2	0.5000	31250
2.097152	0.5243	32768
2.4576	0.6144	38400
3	0.7500	46875
3.6864	0.9216	57600
4	1.0000	62500
4.9152	1.2288	76800
8	2.0000	125000
9.8304	2.4576	153600
12	3.0000	187500
14.7456	3.6864	230400
16	4.0000	250000
30	7.5000	468750

Table 14.7 Maximum Bit Rate with External Clock Input (Synchronous Mode)

Pϕ (MHz)	External Input Clock (MHz)	Maximum Bit Rate (Bits/s)
8	1.3333	1333333.3
16	2.6667	2666666.7
30	5.0	5000000.0

14.2.10 FIFO Control Register (SCFCR)

Bit:	7	6	5	4	3	2	1	0
	RTRG1	RTRG0	TTRG1	TTRG0	MCE	TFRST	RFRST	LOOP
Initial value:	0	0	0	0	0	0	0	0
R/W:	R/W	R/W	R/W	R/W	R/W	R/W	R/W	R/W

The FIFO control register (SCFCR) performs data count resetting and trigger data number setting for the transmit and receive FIFO registers, and also contains a loopback test enable bit.

SCFCR can be read or written to at all times.

SCFCR is initialized to H'00 by a reset, by the module standby function, and in standby mode.

Bits 7 and 6—Receive FIFO Data Number Trigger (RTRG1, RTRG0): These bits are used to set the number of receive data bytes that sets the receive data full (RDF) flag in the serial status 1 register (SC1SSR).

The RDF flag is set when the number of receive data bytes in the receive FIFO data register (SCFRDR) is equal to or greater than the trigger set number shown in the following table.

Bit 7: RTRG1	Bit 6: RTRG0	Receive Trigger Number
0	0	1*
	1	4
1	0	8
	1	14

Note: * Initial value

Bits 5 and 4—Transmit FIFO Data Number Trigger (TTRG1, TTRG0): These bits are used to set the number of remaining transmit data bytes that sets the transmit FIFO data register empty (TDFE) flag in the serial status 1 register (SC1SSR).

The TDFE flag is set when the number of transmit data bytes in the transmit FIFO data register (SCFTDR) is equal to or less than the trigger set number shown in the following table.

Bit 5: TTRG1	Bit 4: TTRG0	Transmit Trigger Number
0	0	8 (8)*
	1	4 (12)
1	0	2 (14)
	1	1 (15)

Note: * Initial value. Figures in parentheses are the number of empty bytes in SCFTDR when the flag is set.

Bit 3—Modem Control Enable (MCE): Enables or disables the $\overline{\text{CTS}}$ and $\overline{\text{RTS}}$ modem control signals.

Bit 3: MCE	Description
0	Modem signals disabled* (Initial value)
1	Modem signals enabled

Note: * $\overline{\text{CTS}}$ is fixed at active-0 regardless of the input value, and $\overline{\text{RTS}}$ output is also fixed at 0.

Bit 2—Transmit FIFO Data Register Reset (TFRST): Invalidates the transmit data in the transmit FIFO data register and resets it to the empty state.

Bit 2: TFRST	Description
0	Reset operation disabled (Initial value)
1	Reset operation enabled

Note: A reset operation is performed in the event of a reset, module standby, or in standby mode.

Bit 1—Receive FIFO Data Register Reset (RFRST): Invalidates the receive data in the receive FIFO data register and resets it to the empty state.

Bit 1: RFRST	Description
0	Reset operation disabled (Initial value)
1	Reset operation enabled

Note: A reset operation is performed in the event of a reset, module standby, or in standby mode.

Bit 0—Loopback Test (LOOP): Internally connects the transmit output pin (TxD) and receive input pin (RxD), enabling loopback testing.

Bit 0: LOOP	Description
0	Loopback test disabled (Initial value)
1	Loopback test enabled

14.2.11 FIFO Data Count Register (SCFDR)

The FIFO data count register (SCFDR) is a 16-bit register that indicates the number of data bytes stored in the transmit FIFO data register (SCFTDR) and receive FIFO data register (SCFRDR).

The upper 8 bits show the number of transmit data bytes in SCFTDR, and the lower 8 bits show the number of receive data bytes in SCFRDR.

SCFDR can be read by the CPU at all times.

SCFDR is initialized to H'00 by a reset, by the module standby function, and in standby mode. It is also initialized to H'00 by setting the TFRST and RFRST bits to 1 in SCFCR to reset SCFTDR and SCFRDR to the empty state.

Upper 8 bits:	15	14	13	12	11	10	9	8
	—	—	—	T4	T3	T2	T1	T0
Initial value:	0	0	0	0	0	0	0	0
R/W:	R	R	R	R	R	R	R	R

Bits 15 to 13—Reserved: These bits are always read as 0. The write value should always be 0.

Bits 12 to 8—Transmit FIFO Data Count 4 to 0 (T4 to T0): These bits show the number of untransmitted data bytes in SCFTDR.

A value of H'00 indicates that there is no transmit data, and a value of H'10 indicates that SCFTDR is full of transmit data. The value is cleared to H'00 by transmitting all the data, as well as by the above initialization conditions.

Lower 8 bits:	7	6	5	4	3	2	1	0
	—	—	—	R4	R3	R2	R1	R0
Initial value:	0	0	0	0	0	0	0	0
R/W:	R	R	R	R	R	R	R	R

Bits 7 to 5—Reserved: These bits are always read as 0. The write value should always be 0.

Bits 4 to 0—Receive FIFO Data Count 4 to 0 (R4 to R0): These bits show the number of receive data bytes in SCFRDR.

A value of H'00 indicates that there is no receive data, and a value of H'10 indicates that SCFRDR is full of receive data. The value is cleared to H'00 by reading all the receive data from SCFRDR, as well as by the above initialization conditions.

14.2.12 FIFO Error Register (SCFER)

The FIFO error register (SCFER) indicates the data location at which a parity error or framing error occurred in receive data stored in the receive FIFO data register (SCFRDR).

SCFER can be read at all times.

Upper 8 bits:	15	14	13	12	11	10	9	8
	ED15	ED14	ED13	ED12	ED11	ED10	ED9	ED8
Initial value:	0	0	0	0	0	0	0	0
R/W:	R	R	R	R	R	R	R	R
Lower 8 bits:	7	6	5	4	3	2	1	0
	ED7	ED6	ED5	ED4	ED3	ED2	ED1	ED0
Initial value:	0	0	0	0	0	0	0	0
R/W:	R	R	R	R	R	R	R	R

Bits 15 to 0—Error Data Flags 15 to 0 (ED15 to ED0): These flags indicate the data location in the receive FIFO data register at which an error occurred. When data in the *n*th stage of the buffer contains an error, the *n*th bit is set to 1. Note that this register is not cleared by setting the RFRST bit to 1 in SCFCR.

Bits 15 to 0:

ED15 to ED0

Description

0	No parity or framing error in data in corresponding stage of register FIFO (Initial value)
1	Parity or framing error present in data in corresponding stage of register FIFO

Note: A reset operation is performed in the event of a reset, when the module standby function is used, or in standby mode. These flags are also cleared by reading the data in which the parity error or framing error occurred from SCFRDR.

14.2.13 IrDA Mode Register (SCIMR)

The IrDA mode register (SCIFMR) allows selection of the IrDA mode and the IrDA output pulse width, and inversion of the IrDA receive data polarity.

SCIMR can be read and written to at all times.

SCIMR is initialized to H'00 by a reset, by the module standby function, and in standby mode.

Bit:	7	6	5	4	3	2	1	0
	IRMOD	PSEL	RIVS	—	—	—	—	—
Initial value:	0	0	0	0	0	0	0	0
R/W:	R/W	R/W	R/W	R	R	R	R	R

Bit 7—IrDA Mode (IRMOD): Selects operation as an IrDA serial communication interface.

Bit 7: IRMOD Description

0	Operation as SCIF is selected	(Initial value)
1	Operation as IrDA is selected*	

Note: * When operation as an IrDA interface is selected, bit 7 (C/\bar{A}) of the serial mode register (SCSMR) must be cleared to 0.

Bit 6—Output Pulse Width Select (PSEL): Selects either 3/16 of the bit length set by bits ICK3 to ICK0 in the serial mode register (SCSMR), or 3/16 of the bit length corresponding to the selected baud rate, as the IrDA output pulse width. The setting is shown together with bits 6 to 3 (ICK3 to ICK0) of the serial mode register (SCSMR).

Serial Mode Register (SCSMR)				SCIMR	
Bit 6: ICK3	Bit 5: ICK2	Bit 4: ICK1	Bit 3: ICK0	Bit 2: PSEL	Description
ICK3	ICK2	ICK1	ICK0	1	Pulse width: 3/16 of bit length set in bits ICK3 to ICK0
Don't care	Don't care	Don't care	Don't care	0	Pulse width: 3/16 of bit length set in SCBRR (Initial value)

Note: A fixed clock pulse signal, IRCLK, must be generated by multiplying the P ϕ clock by 1/2 N + 2 (where N is determined by the value set in ICK3 to ICK0). For details, see section 14.3.6 Pulse Width Selection.

Bit 5—IrDA Receive Data Inverse (RIVS): Allows inversion of the receive data polarity to be selected in IrDA communication.

Bit 5: RIVS Description

0	Receive data polarity inverted in reception	(Initial value)
1	Receive data polarity not inverted in reception	

Note: Make the selection according to the characteristics of the IrDA modulation/demodulation module.

Bits 4 to 0—Reserved: These bits are always read as 0. The write value should always be 0.

14.3 Operation

14.3.1 Overview

The SCIF can carry out serial communication in two modes: asynchronous mode in which synchronization is achieved character by character, and synchronous mode in which synchronization is achieved with clock pulses.

An IrDA block is also provided, enabling infrared communication conforming to IrDA 1.0 to be executed by connecting an infrared transmission/reception unit.

Sixteen-stage FIFO buffers are provided for both transmission and reception, reducing the CPU overhead and enabling fast, continuous communication to be performed.

Selection of asynchronous, synchronous, or IrDA mode and the transmission format is made by means of the serial mode register (SCSMR) and IrDA mode register (SCIMR) as shown in table 14.8. The SCIF clock source is determined by a combination of the C/\bar{A} bit in SCSMR, the IRMOD bit in SCIMR, and the CKE1 and CKE0 bits in the serial control register (SCSCR), as shown in table 14.9.

- Asynchronous Mode
 - Data length: Choice of 7 or 8 bits
 - Choice of parity addition, multiprocessor bit addition, and addition of 1 or 2 stop bits (the combination of these parameters determines the transmit/receive format and character length)
 - Detection of framing, parity, and overrun errors, receive FIFO data full and receive data ready conditions, and breaks, during reception
 - Detection of transmit FIFO data empty condition during transmission
 - Choice of internal or external clock as SCIF clock source
 - When internal clock is selected: The SCIF operates on a clock with a frequency of 16, 8, or 4 times the bit rate of the baud rate generator, and can output this operating clock.
 - When external clock is selected: A clock with a frequency of 16, 8, or 4 times the bit rate must be input (the built-in baud rate generator is not used).
- Synchronous Mode
 - Transmit/receive format: Fixed 8-bit data
 - Detection of overrun errors during reception
 - Choice of internal or external clock as SCIF clock source
 - When internal clock is selected: The SCIF operates on the baud rate generator clock and can output a serial clock to external devices.
 - When external clock is selected: The on-chip baud rate generator is not used, and the SCIF operates on the input serial clock.

- IrDA Mode
 - IrDA 1.0 compliance
 - Data length: 8 bits
 - Stop bit length: 1 bit
 - Protection function to prevent receiver being affected during transmission
 - Clock source: Internal clock

Table 14.8 SCSMR and SCIMR Settings for Serial Transmit/Receive Format Selection

SCIMR		SCSMR Settings					SCIF Transmit/Receive Format				
Bit 7: IRMOD	Bit 7: C/ \bar{A}	Bit 6: CHR	Bit 2: MP	Bit 5: PE	Bit 3: STOP	Mode	Data Length	MP Bit	Parity Bit	Stop Bit Length	
0	0	0	0	0	0	Asynchronous mode	8-bit data	Absent	Absent	1 bit	
					1					2 bits	
					0					1 bit	
					1					2 bits	
					0					1 bit	
					1					2 bits	
		1	0	1	0	0	Asynchronous mode (multi- processor format)	8-bit data	Present	Absent	1 bit
						1					2 bits
						0					1 bit
						1					2 bits
						0					1 bit
						1					2 bits
0	1	*	*	*	*	Synchronous mode	8-bit data	Absent	Absent	None	
										1	1 bit
1	0	ICK3	ICK2	ICK1	ICK0	IrDA mode	8-bit data	Absent	Absent	1 bit	
										1	*

Note: An asterisk in the table means "Don't care."

Table 14.9 SCSMR and SCSCR Settings for SCIF Clock Source Selection

SCSMR Bit 7: C/A	SCSCR Setting		Mode	SCIF Transmit/Receive Clock	
	Bit 1: CKE1	Bit 0: CKE0		Clock Source	SCK Pin Function
0	0	0	Asynchronous mode	Internal	SCIF does not use SCK pin
		1			Outputs clock with frequency of 16/8/4 times bit rate
	1	0		External	Inputs clock with frequency of 16/8/4 times bit rate
		1			
1	0	0	Synchronous mode	Internal	Outputs serial clock
		1			
	1	0		External	Inputs serial clock
		1			

14.3.2 Operation in Asynchronous Mode

In asynchronous mode, characters are sent or received, each preceded by a start bit indicating the start of communication and followed by one or two stop bits indicating the end of communication. Serial communication is thus carried out with synchronization established on a character-by-character basis.

Inside the SCIF, the transmitter and receiver are independent units, enabling full-duplex communication. Both the transmitter and the receiver also have a 16-stage FIFO buffer structure, so that data can be read or written during transmission or reception, enabling continuous data transfer.

Figure 14.3 shows the general format for asynchronous serial communication.

In asynchronous serial communication, the communication line is usually held in the mark state (high level). The SCIF monitors the line, and when it goes to the space state (low level), recognizes a start bit and starts serial communication.

One serial communication character consists of a start bit (low level), followed by data (LSB-first or MSB-first order selectable), a parity bit or multiprocessor bit (high or low level), and finally one or two stop bits (high level).

In asynchronous mode, the SCIF performs synchronization at the falling edge of the start bit in reception. The SCIF samples the data on the eighth (fourth, second) pulse of a clock with a frequency of 16 (8, 4) times the length of one bit, so that the transfer data is latched at the center of each bit.

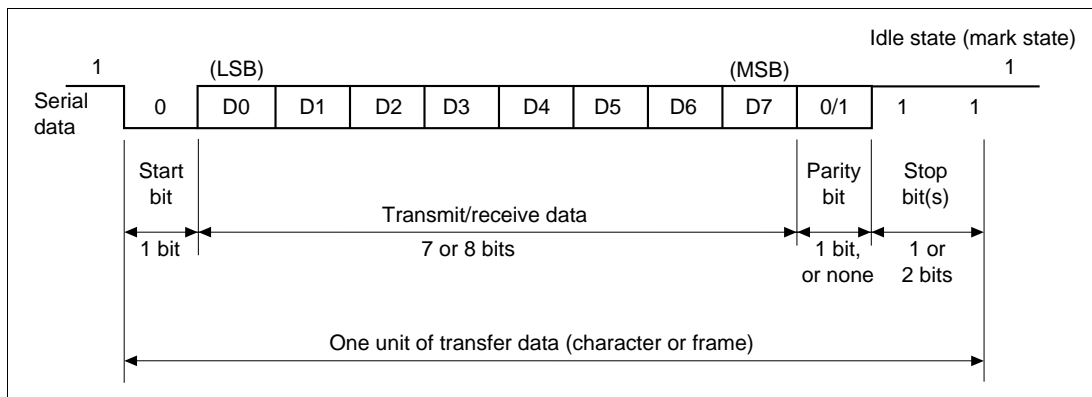

Figure 14.3 Data Format in Asynchronous Communication
(Example with 8-Bit Data, Parity, Two Stop Bits, LSB-First Transfer)

Transmit/Receive Format: Table 14.10 shows the transmit/receive formats that can be used in asynchronous mode. Any of 12 transmit/receive formats can be selected by means of settings in the serial mode register (SCSMR).

Table 14.10 Serial Transmit/Receive Formats (Asynchronous Mode)

SCSMR Settings				Serial Transmit/Receive Format and Frame Length												
CHR	PE	MP	STOP	1	2	3	4	5	6	7	8	9	10	11	12	
0	0	0	0	S	8-bit data								STOP			
			1	S	8-bit data								STOP	STOP		
	1	0	S	8-bit data								P	STOP			
		1	S	8-bit data								P	STOP	STOP		
1	0	0	0	S	8-bit data								STOP			
			1	S	8-bit data								STOP	STOP		
	1	0	S	7-bit data							P	STOP				
		1	S	7-bit data							P	STOP	STOP			
0	*	1	0	S	8-bit data								MPB	STOP		
			1	S	8-bit data								MPB	STOP	STOP	
1	*	0	0	S	7-bit data							MPB	STOP			
			1	S	7-bit data							MPB	STOP	STOP		

Note: An asterisk in the table means "Don't care."

Legend

S: Start bit

STOP: Stop bit

P: Parity bit

MPB: Multiprocessor bit

Clock: Either an internal clock generated by the built-in baud rate generator or an external clock input at the SCK pin can be selected as the SCI's serial clock, according to the setting of the C/\overline{A} bit in SCSMR and the CKE1 and CKE0 bits in SCSCR. For details of SCIF clock source selection, see table 14.9.

When an external clock is input at the SCK pin, the input clock frequency should be 16, 8, or 4 times the bit rate used.

When the SCIF is operated on an internal clock, the clock can be output from the SCK pin. The frequency of the clock output in this case is 16, 8, or 4 times the bit rate.

Data Transmit/Receive Operations

- SCIF Initialization (Asynchronous Mode)

Before transmitting and receiving data, it is necessary to clear the TE and RE bits to 0 in SCSCR, then initialize the SCIF as described below.

When the operating mode, communication format, etc., is changed, the TE and RE bits must be cleared to 0 before making the change using the following procedure. When the TE bit is cleared to 0, the transmit shift register (SCTSR) is initialized. Note that clearing the TE and RE bits to 0 does not change the contents of the serial status 1 register (SC1SSR), the transmit FIFO data register (SCFTDR), or the receive FIFO data register (SCFRDR). The TE bit should not be cleared to 0 until all transmit data has been transmitted and the TEND flag has been set in SC1SSR. It is possible to clear the TE bit to 0 during transmission, but the data being transmitted will go to the high-impedance state after TE is cleared. Also, before starting transmission by setting TE again, the TFRST bit should first be set to 1 in SCFCR to reset SCFTDR.

When an external clock is used the clock should not be stopped during operation, including initialization, since operation will be unreliable in this case.

Figure 14.4 shows a sample SCIF initialization flowchart.

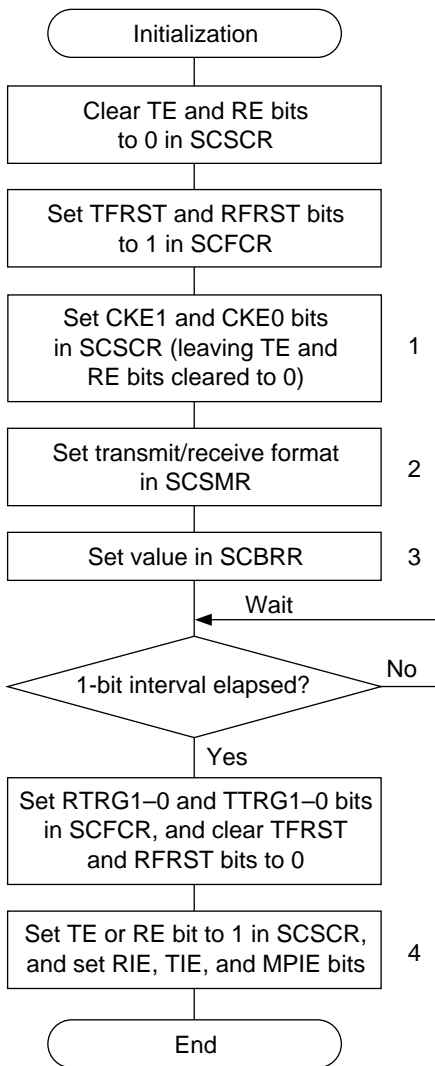

1. Set the clock selection in SCSCR. Be sure to clear bits RIE, TIE, and MPIE, and bits TE and RE, to 0. When clock output is selected in asynchronous mode, it is output immediately after SCSCR settings are made. Select input or output for the SCK pin with the PFC.
2. Set the transmit/receive format in SCSMR. When using IrDA mode, also set SCIFMR.
3. Write a value corresponding to the bit rate into the bit rate register (SCBRR). (Not necessary if an external clock is used.)
4. Wait at least one bit interval, then set the TE bit or RE bit in SCSCR to 1. Also set the RIE, TIE, and MPIE bits. Setting the TE and RE bits enables the TxD and RxD pins to be used. When transmitting, the SCIF will go to the mark state; when receiving, it will go to the idle state, waiting for a start bit.

Figure 14.4 Sample SCIF Initialization Flowchart

- Serial Data Transmission (Asynchronous Mode)

Figure 14.5 shows a sample flowchart for serial transmission.

Use the following procedure for serial data transmission after enabling the SCIF for transmission.

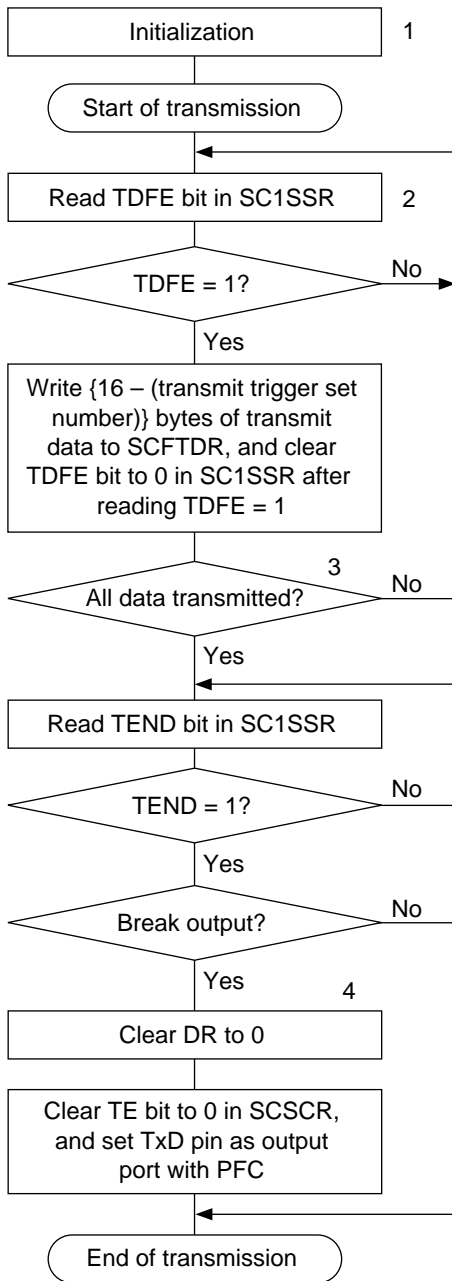

1. PFC initialization: Set the TxD pin, and the SCK pin if necessary, with the PFC.
2. SCIF status check and transmit data write: Read the serial status 1 register (SC1SSR) and check that the TDFE bit is set to 1, then write transmit data to the transmit FIFO data register (SCFTDR) and clear the TDFE bit to 0 after reading TDFE = 1. The TEND bit is cleared automatically when transmission is started by writing transmit data.

The number of data bytes that can be written is {16 – (transmit trigger set number)}.

3. Serial transmission continuation procedure: To continue serial transmission, read 1 from the TDFE bit to confirm that writing is possible, then write data to SCFTDR, and then clear the TDFE bit to 0. (Checking and clearing of the TDFE bit is automatic when the DMAC is activated by a transmit-FIFO-data-empty interrupt (TXI) request, and data is written to SCFTDR.)
4. Break output at the end of serial transmission: To output a break in serial transmission, clear the port data register (DR) to 0, then clear the TE bit to 0 in SCSCR, and set the TxD pin as an output port with the PFC.

In steps 2 and 3, the number of transmit data bytes that can be written can be ascertained from the number of transmit data bytes in SCFTDR indicated in the upper 8 bits of the FIFO data count register (SCFDR).

Figure 14.5 Sample Serial Transmission Flowchart

In serial transmission, the SCIF operates as described below.

1. When data is written to the transmit FIFO data register (SCFTDR), the SCIF transfers the data to the transmit shift register (SCTSR), and starts transmitting. Check that the TDFE flag is set to 1 in the serial status 1 register (SC1SSR) before writing transmit data to SCFTDR. The number of data bytes that can be written is at least { 16 – (transmit trigger set number)}.
2. When data is transferred from SCFTDR to SCTSR and transmission is started, transmit operations are performed continually until there is no transmit data left in SCFTDR. If the number of data bytes in SCFTDR falls to or below the transmit trigger number set in the FIFO control register (SCFCR) during transmission, the TDFE flag is set. If the TE bit setting in the serial control register (SCSCR) is 1 at this time, a transmit-FIFO-data-empty interrupt (TXI) is requested.

The serial transmit data is sent from the TxD pin in the following order.

- a. Start bit: One 0-bit is output.
 - b. Transmit data: 8-bit or 7-bit data is output in LSB-first or MSB-first order according to the setting of the TLM bit in SC2SSR.
 - c. Parity bit or multiprocessor bit: One parity bit (even or odd parity), or one multiprocessor bit is output. (A format in which neither a parity bit nor a multiprocessor bit is output can also be selected.)
 - d. Stop bit(s): One or two 1-bits (stop bits) are output.
 - e. Mark state: 1 is output continuously until the start bit that starts the next transmission is sent.
3. The SCIF checks for transmit data in SCFTDR at the timing for sending the stop bit. If there is data in SCFTDR, it is transferred to SCTSR, the stop bit is sent, and then serial transmission of the next frame is started.

If there is no transmit data in SCFTDR, the TEND flag is set to 1 in the serial status 1 register (SC1SSR), the stop bit is sent, and then the line goes to the mark state in which 1 is output continuously.

Figure 14.6 shows an example of the operation for transmission in asynchronous mode.

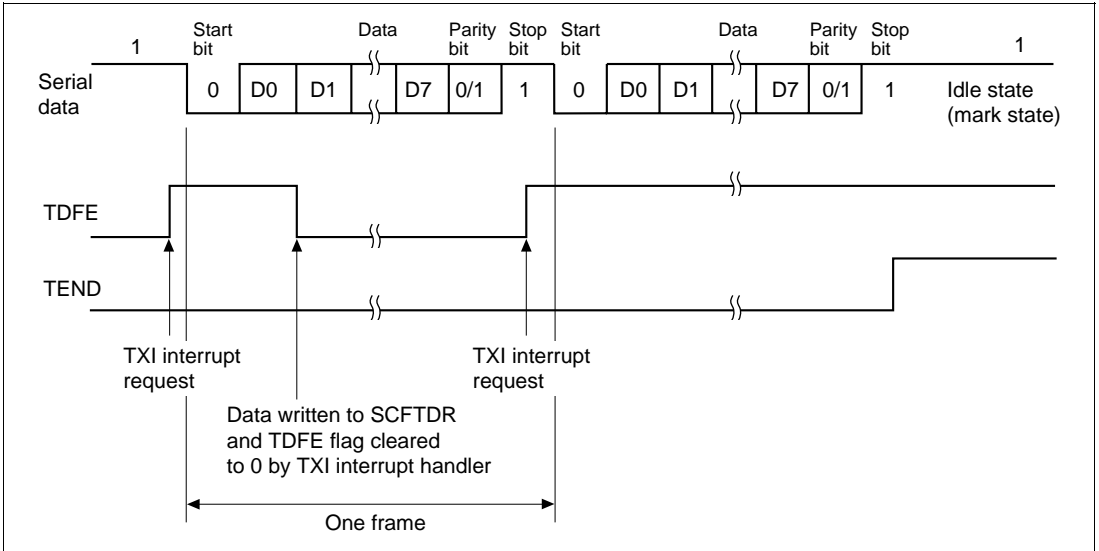

**Figure 14.6 Example of Transmit Operation in Asynchronous Mode
(Example with 8-Bit Data, Parity, One Stop Bit, LSB-First Transfer)**

- When modem control is enabled, transmission can be stopped and restarted in accordance with the $\overline{\text{CTS}}$ input value. When $\overline{\text{CTS}}$ is set to 1, if transmission is in progress, the line goes to the mark state after transmission of one frame. When $\overline{\text{CTS}}$ is set to 0, the next transmit data is output starting from the start bit.

Figure 14.7 shows an example of the operation when modem control is used.

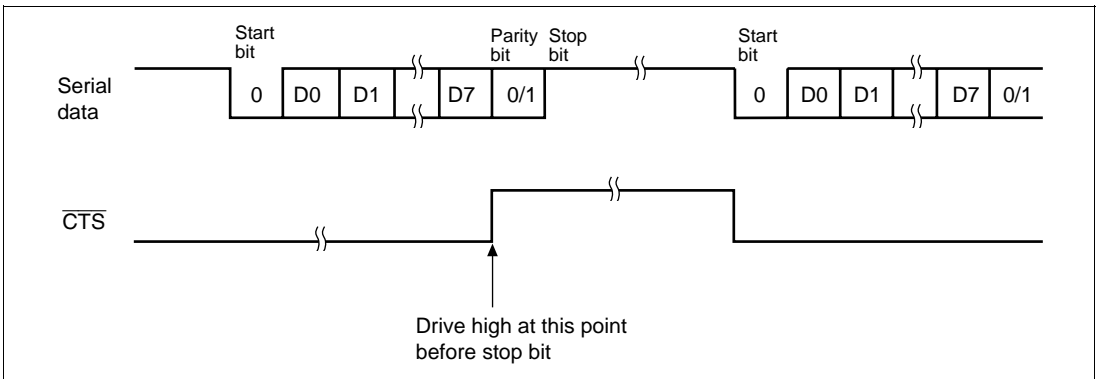
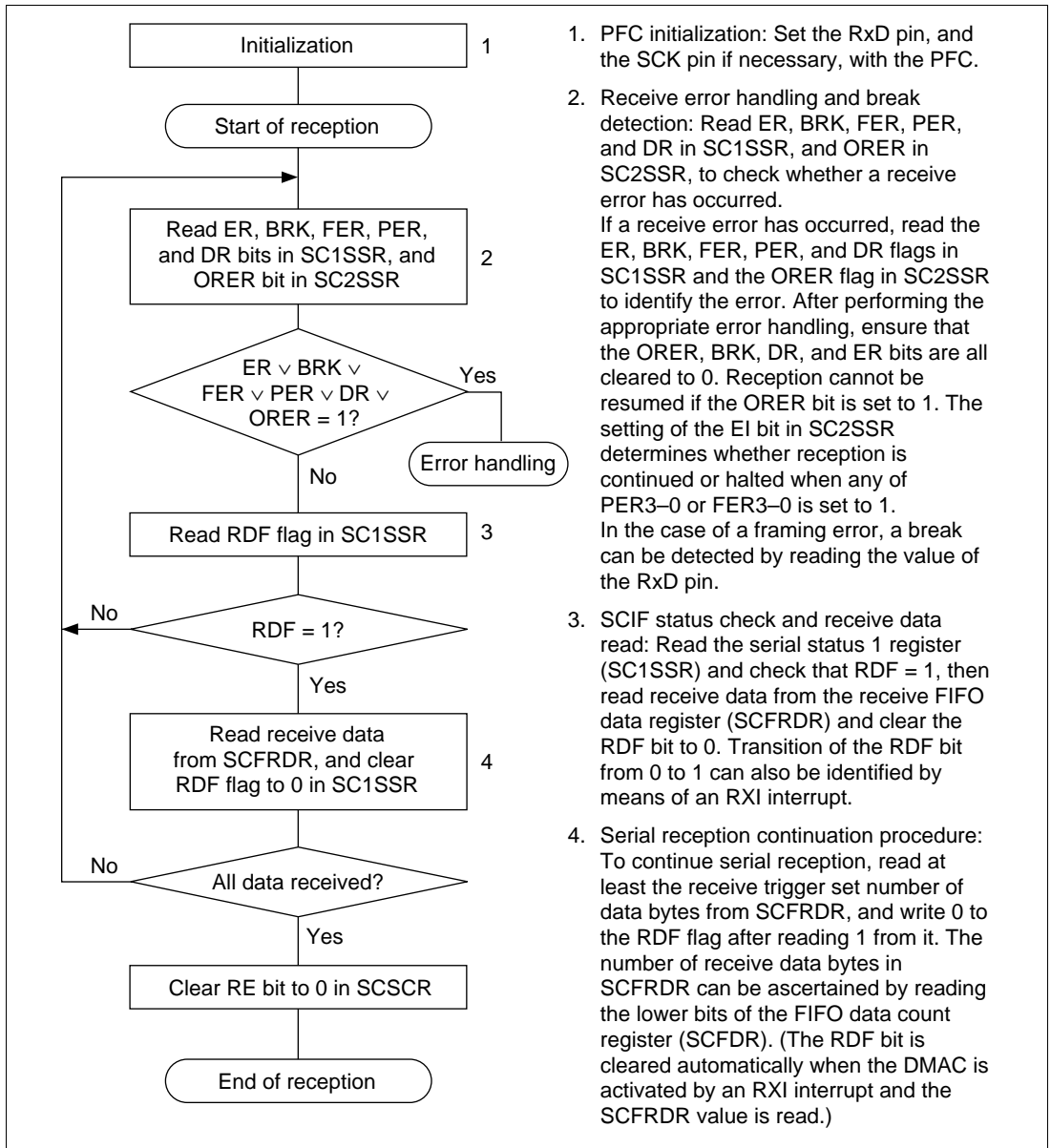

Figure 14.7 Example of Operation Using Modem Control ($\overline{\text{CTS}}$)

- Serial Data Reception (Asynchronous Mode)

Figure 14.8 shows a sample flowchart for serial reception.

Use the following procedure for serial data reception after enabling the SCIF for reception.



1. PFC initialization: Set the RxD pin, and the SCK pin if necessary, with the PFC.

2. Receive error handling and break detection: Read ER, BRK, FER, PER, and DR in SC1SSR, and ORER in SC2SSR, to check whether a receive error has occurred. If a receive error has occurred, read the ER, BRK, FER, PER, and DR flags in SC1SSR and the ORER flag in SC2SSR to identify the error. After performing the appropriate error handling, ensure that the ORER, BRK, DR, and ER bits are all cleared to 0. Reception cannot be resumed if the ORER bit is set to 1. The setting of the EI bit in SC2SSR determines whether reception is continued or halted when any of PER3-0 or FER3-0 is set to 1. In the case of a framing error, a break can be detected by reading the value of the RxD pin.

3. SCIF status check and receive data read: Read the serial status 1 register (SC1SSR) and check that RDF = 1, then read receive data from the receive FIFO data register (SCFRDR) and clear the RDF bit to 0. Transition of the RDF bit from 0 to 1 can also be identified by means of an RXI interrupt.

4. Serial reception continuation procedure: To continue serial reception, read at least the receive trigger set number of data bytes from SCFRDR, and write 0 to the RDF flag after reading 1 from it. The number of receive data bytes in SCFRDR can be ascertained by reading the lower bits of the FIFO data count register (SCFDR). (The RDF bit is cleared automatically when the DMAC is activated by an RXI interrupt and the SCFRDR value is read.)

Figure 14.8 Sample Serial Reception Flowchart (1)

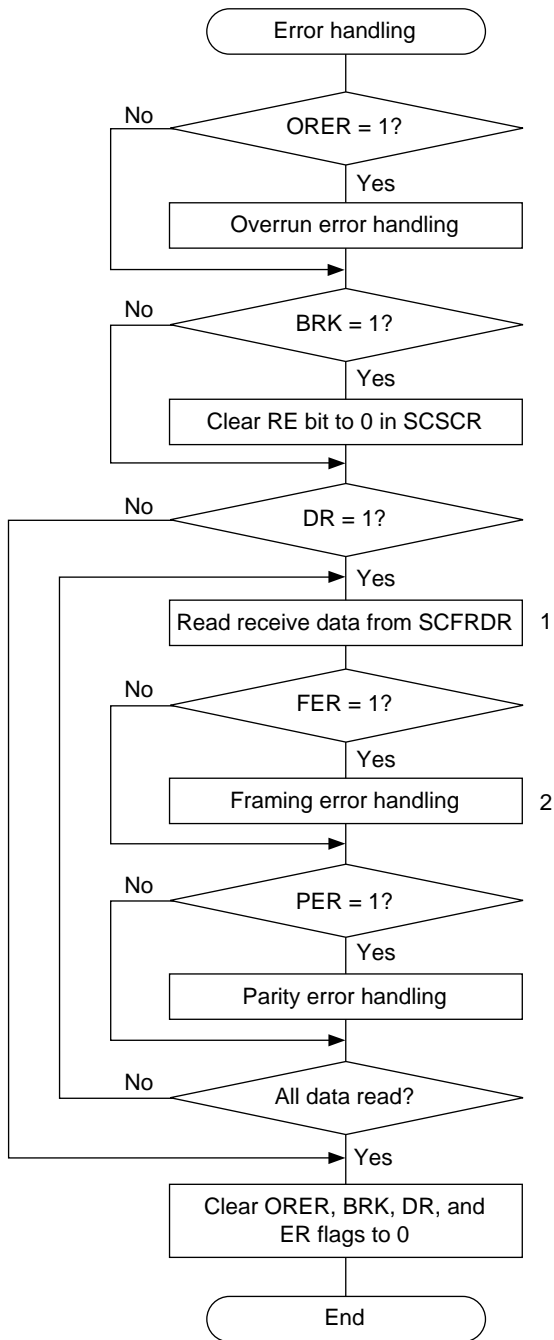

1. Whether a framing error or parity error has occurred in the receive data read from SCFRDR can be ascertained from the FER and PER bits in SC1SSR.
2. When a break signal is received, receive data is not transferred to SCFRDR while the BRK flag is set. However, note that the H'00 break data in which a framing error occurred is stored as the last data in SCFRDR.

Figure 14.8 Sample Serial Reception Flowchart (2)

In serial reception, the SCIF operates as described below.

1. The SCIF monitors the communication line, and if a 0 start bit is detected, performs internal synchronization and starts reception.
2. The received data is stored in SCRSR in LSB-to-MSB order or MSB-to-LSB order according to the setting of the RLM bit in SC2SSR.
3. The parity bit and stop bit are received.

After receiving these bits, the SCIF carries out the following checks.

- a. Parity check: The SCIF checks whether the number of 1-bits in the receive data agrees with the parity (even or odd) set in the O/\bar{E} bit in the serial mode register (SCSMR).
- b. Stop bit check: The SCIF checks whether the stop bit is 1. If there are two stop bits, only the first is checked.
- c. Status check: The SCIF checks whether receive data can be transferred from the receive shift register (SCRSR) to SCFRDR.
- d. Break check: The SCIF checks that the BRK flag is 0, indicating no break.

If all the above checks are passed, the receive data is stored in SCFRDR. If a receive error is detected in the error check, the operation is as shown in table 14.11.

Note: No further receive operations can be performed when an overrun error has occurred. The setting of the EI bit in SC2SSR determines whether reception is continued or halted when a framing error or parity error occurs.

Also, as the RDF flag is not set to 1 when receiving, the error flags must be cleared to 0.

4. If the RIE bit setting in SCSCR is 1 when the RDF or DR flag is set to 1, a receive-FIFO-data-full interrupt (RXI) is requested.

If the RIE bit setting in SCSCR is 1 when the ORER, PER, or FER flag is set to 1, a receive-error interrupt (ERI) is requested.

If the RIE bit setting in SCSCR is 1 when the BRK flag is set to 1, a break-receive interrupt (BRI) is requested.

Table 14.11 Receive Error Conditions

Receive Error	Abbreviation	Condition	Data Transfer
Overrun error	ORER	Next serial receive operation is completed while there are 16 receive data bytes in SCFRDR	Receive data is not transferred from SCRSR to SCFRDR
Framing error	FER	Stop bit is 0	Receive data is transferred from SCRSR to SCFRDR
Parity error	PER	Received data parity differs from that (even or odd) set in SCSMR	Receive data is transferred from SCRSR to SCFRDR

Figure 14.9 shows an example of the operation for reception in asynchronous mode.

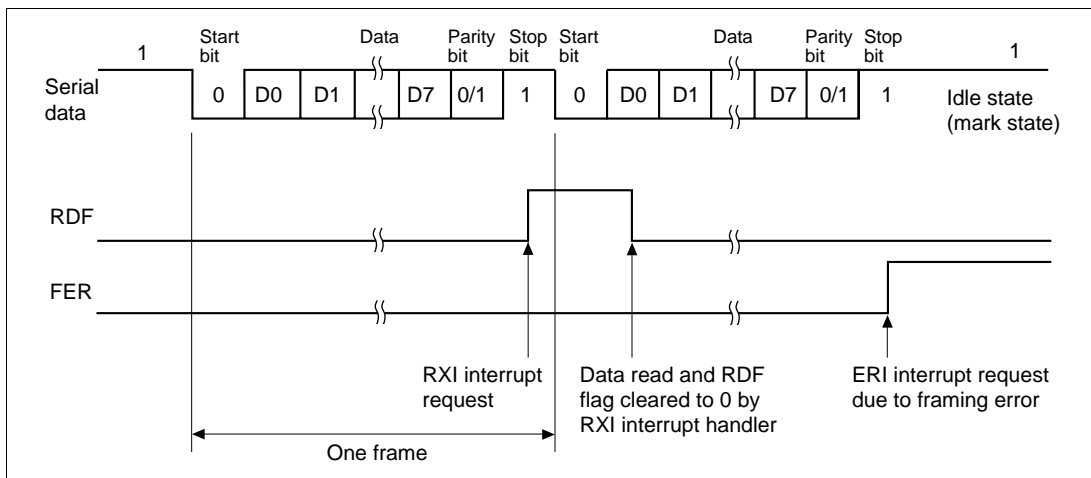

**Figure 14.9 Example of SCIF Receive Operation
(Example with 8-Bit Data, Parity, One Stop Bit, LSB-First Transfer)**

- When modem control is enabled, the $\overline{\text{RTS}}$ signal is output when SCFRDR is empty. When $\overline{\text{RTS}}$ is 0, reception is possible. When $\overline{\text{RTS}}$ is 1, this indicates that SCFRDR is full and reception is not possible.

Figure 14.10 shows an example of the operation when modem control is used.

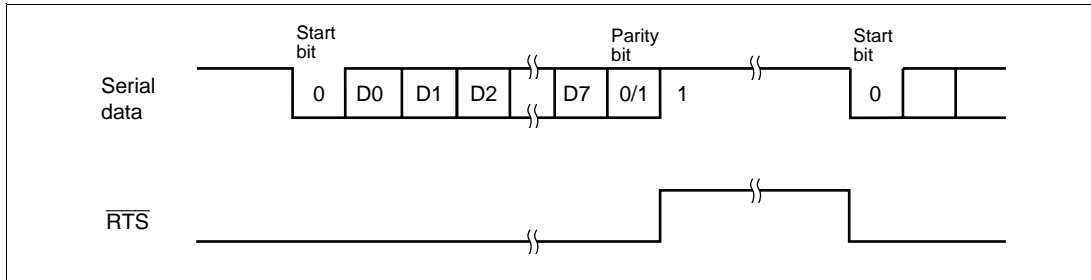

Figure 14.10 Example of Operation Using Modem Control ($\overline{\text{RTS}}$)

14.3.3 Multiprocessor Communication Function

The multiprocessor communication function performs serial communication using a multiprocessor format, in which a multiprocessor bit is added to the transfer data, in asynchronous mode. Use of this function enables data transfer to be performed among a number of processors sharing a serial communication line.

When multiprocessor communication is carried out, each receiving station is addressed by a unique ID code.

The serial communication cycle consists of two cycles: an ID transmission cycle which specifies the receiving station, and a data transmission cycle. The multiprocessor bit is used to differentiate between the ID transmission cycle and the data transmission cycle.

The transmitting station first sends the ID of the receiving station with which it wants to perform serial communication as data with a 1 multiprocessor bit added. It then sends transmit data as data with a 0 multiprocessor bit added.

The receiving stations skip the data until data with a 1 multiprocessor bit is sent. When data with a 1 multiprocessor bit is received, each receiving stations compares that data with its own ID. The station whose ID matches then receives the data sent next. Stations whose ID does not match continue to skip the data until data with a 1 multiprocessor bit is again received. In this way, data communication is carried out among a number of processors.

Figure 14.11 shows an example of inter-processor communication using a multiprocessor format.

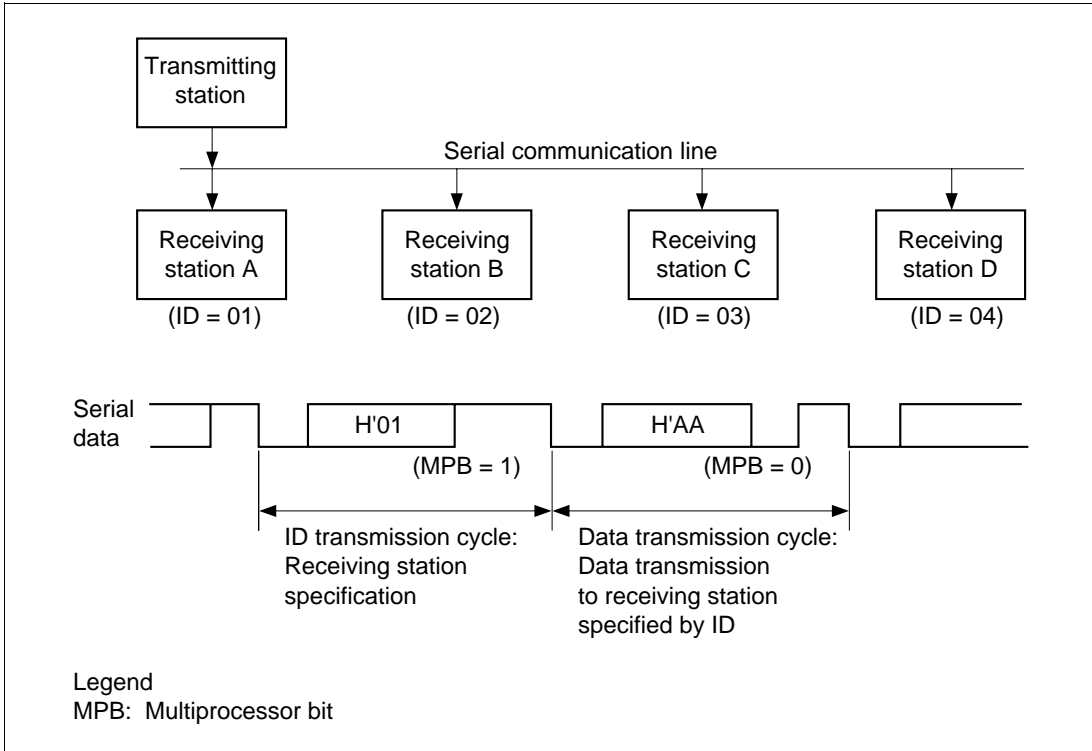

Figure 14.11 Example of Inter-Processor Communication Using Multiprocessor Format (Transmission of Data H'AA to Receiving Station A)

Transmit/Receive Formats: There are four transmit/receive formats. When the multiprocessor format is specified, the parity bit specification is invalid. For details, see table 14.10.

Clock: See the section on asynchronous mode.

Data Transmit/Receive Operations

- SCI Initialization
See the section on asynchronous mode.
- Multiprocessor Serial Data Transmission
Figure 14.12 shows a sample flowchart for multiprocessor serial data transmission. Use the following procedure for multiprocessor serial data transmission after enabling the SCIF for transmission.

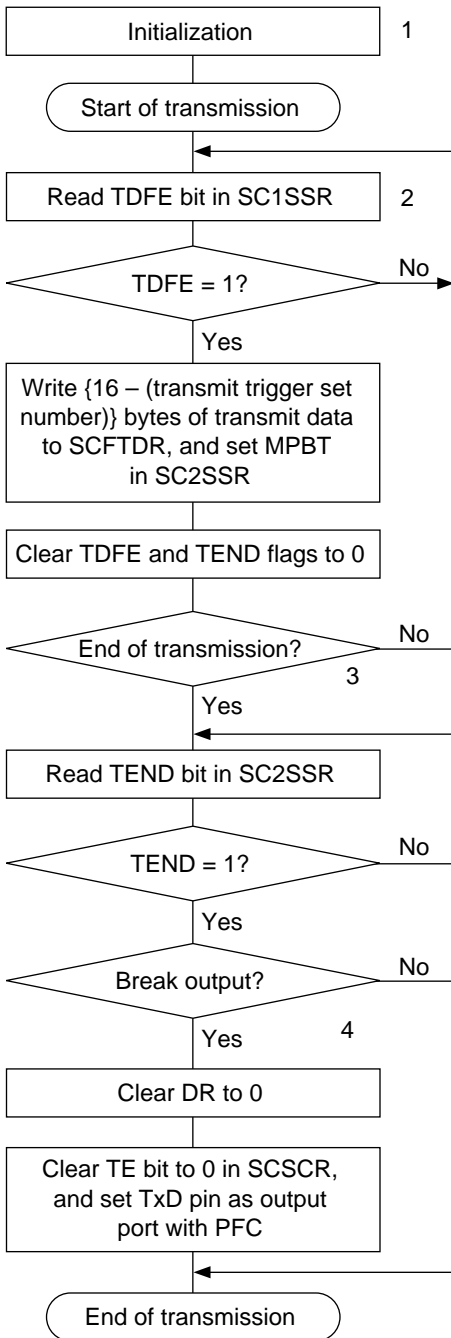

1. PFC initialization: Set the TxD pin, and the SCK pin if necessary, with the PFC.
2. SCIF status check and transmit data write: Read the serial status 1 register (SC1SSR) and check that the TDFE bit is set to 1, then write transmit data to the transmit FIFO data register (SCFTDR). Set the MPBT bit to 0 or 1 in SC1SSR. Finally, clear the TDFE and TEND flags to 0 after reading 1 from them.
The number of data bytes that can be written is {16 - (transmit trigger set number)}.
3. Serial transmission continuation procedure: To continue serial transmission, read 1 from the TDFE bit to confirm that writing is possible, then write data to SCFTDR, and then clear the TDFE bit to 0. (Checking and clearing of the TDFE bit is automatic when the DMAC is activated by a transmit-FIFO-data-empty interrupt (TXI) request, and data is written to SCFTDR.)
4. Break output at the end of serial transmission: To output a break in serial transmission, clear the port data register (DR) to 0, then clear the TE bit to 0 in SCSCR, and set the TxD pin as an output port with the PFC.

In steps 2 and 3, the number of transmit data bytes that can be written can be ascertained from the number of transmit data bytes in SCFTDR indicated in the upper 8 bits of the FIFO data count register (SCFDR).

Figure 14.12 Sample Multiprocessor Serial Transmission Flowchart

In serial transmission, the SCIF operates as described below.

1. When data is written to SCFTDR, the SCIF transfers the data to SCTSR and starts transmitting. Check that the TDFE flag is set to 1 in SC1SSR before writing transmit data to SCFTDR. The number of data bytes that can be written is at least $\{16 - (\text{transmit trigger set number})\}$.
2. When data is transferred from SCFTDR to SCTSR and transmission is started, transmit operations are performed continually until there is no transmit data left in SCFTDR. If the number of data bytes in SCFTDR falls to or below the transmit trigger number set in SCFCR during transmission, the TDFE flag is set to 1. If the TIE bit setting in SCSCR is 1 at this time, a transmit-FIFO-data-empty interrupt (TXI) is requested.

The serial transmit data is sent from the TxD pin in the following order.

- a. Start bit: One 0-bit is output.
 - b. Transmit data: 8-bit or 7-bit data is output in LSB-first or MSB-first order according to the setting of the TLM bit in SC2SSR.
 - c. Multiprocessor bit: One multiprocessor bit (MPBT value) is output.
 - d. Stop bit(s): One or two 1-bits (stop bits) are output.
 - e. Mark state: 1 is output continuously until the start bit that starts the next transmission is sent.
3. The SCIF checks for transmit data in SCFTDR at the timing for sending the stop bit. If there is data in SCFTDR, it is transferred to SCTSR, the stop bit is sent, and then serial transmission of the next frame is started.

If there is no transmit data in SCFTDR, the TEND flag is set to 1 in SC1SSR, the stop bit is sent, and then the line goes to the mark state in which 1 is output continuously.

Figure 14.13 shows an example of SCIF operation for transmission using a multiprocessor format.

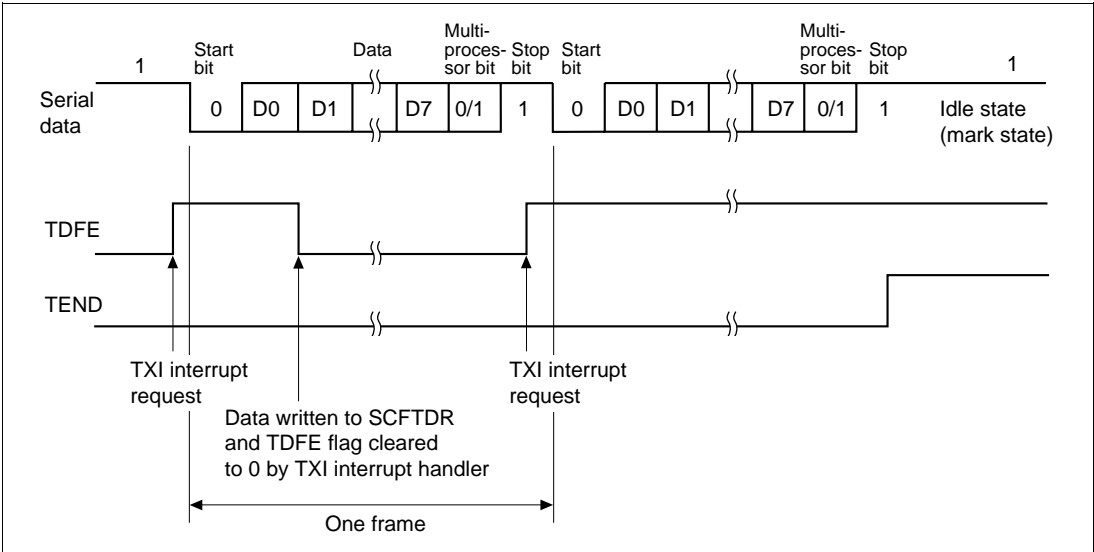
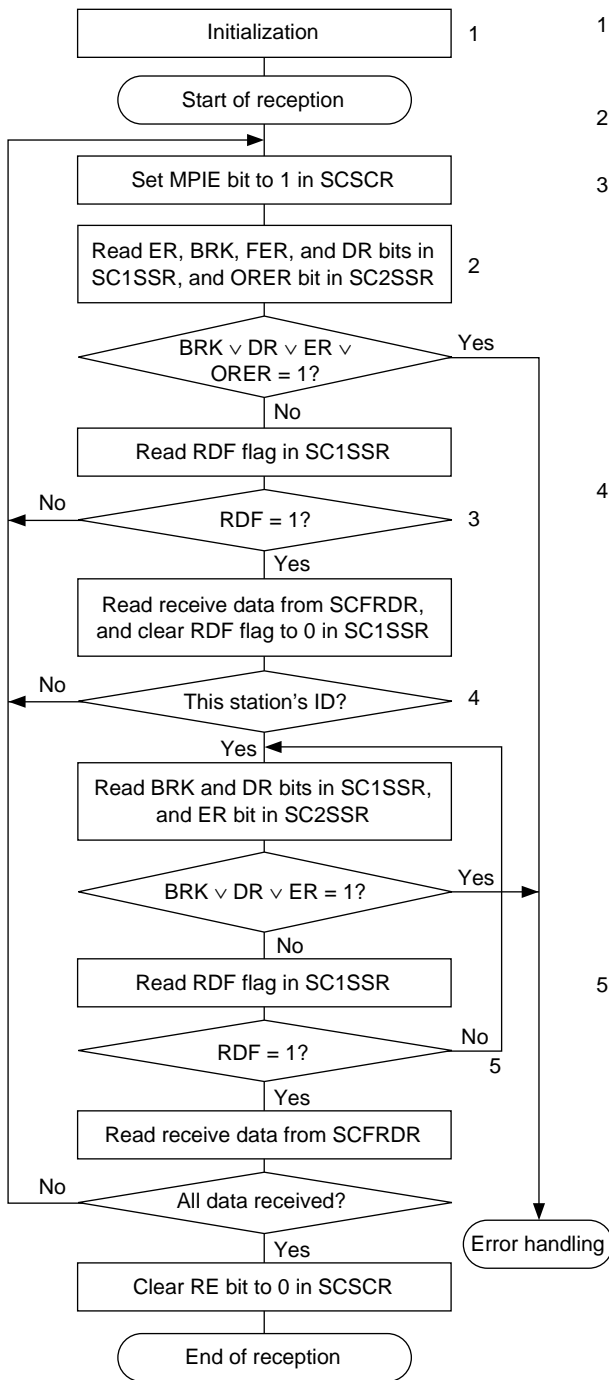

Figure 14.13 Example of SCIF Transmit Operation
(Example with 8-Bit Data, Multiprocessor Bit, One Stop Bit, LSB-First Transfer)

- Multiprocessor Serial Data Reception

Figure 14.14 shows a sample flowchart for multiprocessor serial reception.

Use the following procedure for multiprocessor serial data reception after enabling the SCIF for reception.



1. PFC initialization: Set the RxD pin, and the SCK pin if necessary, with the PFC.
2. ID reception cycle: Set the MPIE bit to 1 in SCSCR.
3. SCIF status check, ID reception and comparison: Read SC1SSR and check that the RDF bit is set to 1, then read the receive data in the receive FIFO data register (SCFRDR) and compare it with this station's ID. If the data is not this station's ID, set the MPIE bit to 1 again, and clear the RDF bit to 0. If the data is this station's ID, clear the RDF bit to 0.
4. Receive error handling and break detection: Read the ER, BRK, FER, and DR flags in SC1SSR and the ORER flag in SC2SSR to check whether a receive error has occurred. If a receive error has occurred, read the ER, BRK, FER, and DR flags in SC1SSR and the ORER flag in SC2SSR to identify the error. After performing the appropriate error handling, ensure that ER, BRK, DR, and ORER are all cleared to 0. The setting of the EI bit in SC2SSR determines whether reception is continued or halted when the ORER bit is set to 1. In the case of a framing error, a break can be detected by reading the value of the RxD pin.
5. SCIF status check and receive data read: Read the serial status 1 register (SC1SSR) and check that RDF = 1, then read receive data from the receive FIFO data register (SCFRDR).

Figure 14.14 Sample Multiprocessor Serial Reception Flowchart (1)

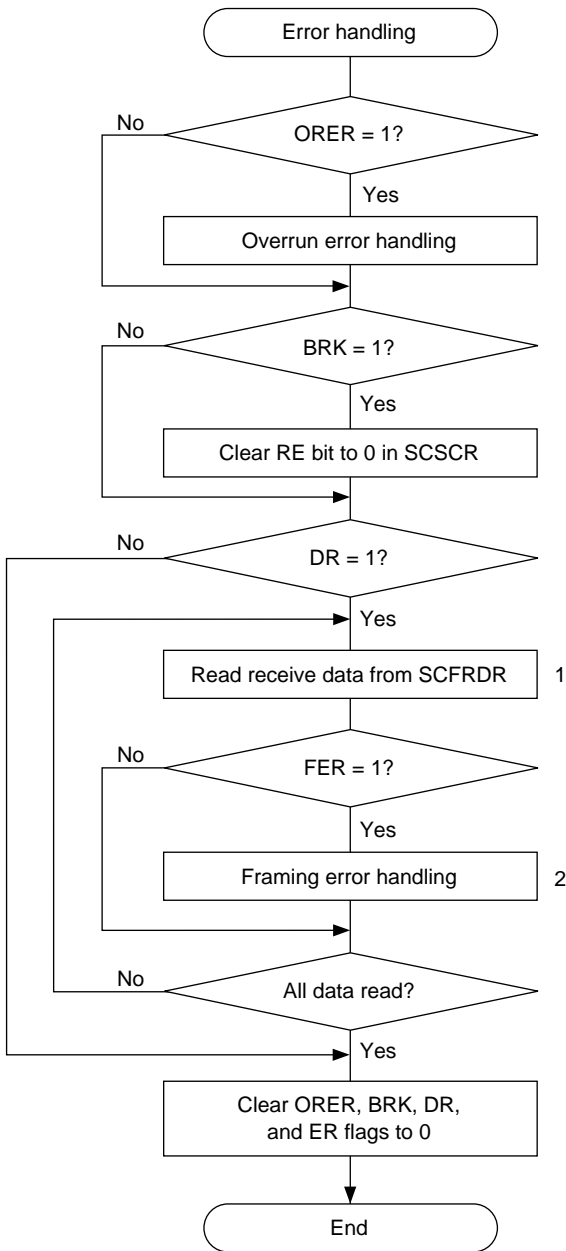

1. Whether a framing error has occurred in the receive data read from SCFRDR can be ascertained from the FER bit in SC1SSR.
2. When a break signal is received, receive data is not transferred to SCFRDR while the BRK flag is set. However, note that the last data in SCFRDR is H'00 and the break data in which a framing error occurred is stored. However, note that the H'00 break data in which a framing error occurred is stored as the last data in SCFRDR.

Figure 14.14 Sample Multiprocessor Serial Reception Flowchart (2)

Figure 14.15 shows an example of SCIF operation for multiprocessor format reception.

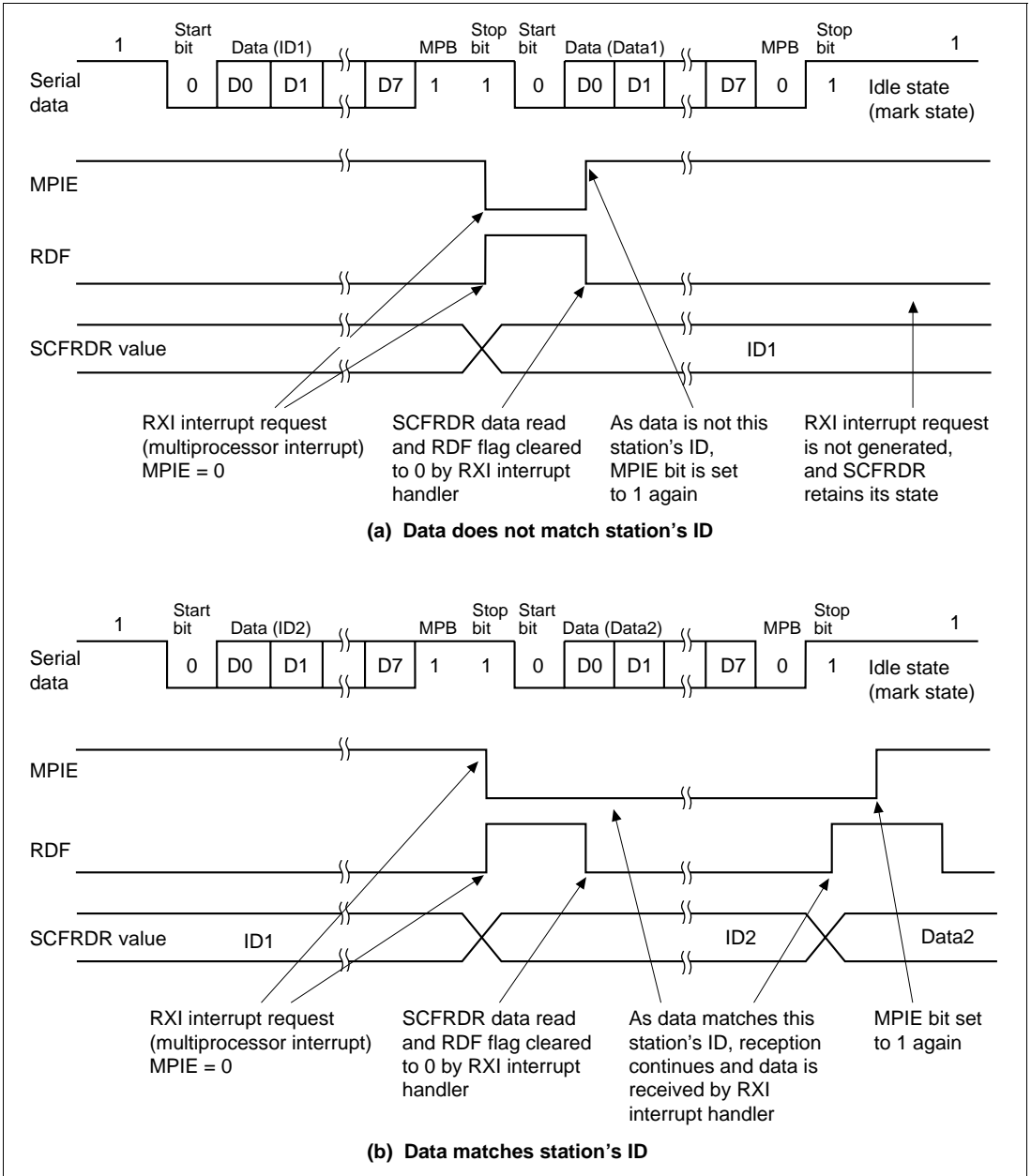

Figure 14.15 Example of SCIF Receive Operation
(Example with 8-Bit Data, Multiprocessor Bit, One Stop Bit, LSB-First Transfer)

14.3.4 Operation in Synchronous Mode

In synchronous mode, data is transmitted or received in synchronization with clock pulses, making it suitable for high-speed serial communication.

Inside the SCIF, the transmitter and receiver are independent units, enabling full-duplex communication using a common clock. Both the transmitter and the receiver also have a 16-stage FIFO buffer structure, so that data can be read or written during transmission or reception, enabling continuous data transfer.

Figure 14.16 shows the general format for synchronous serial communication.

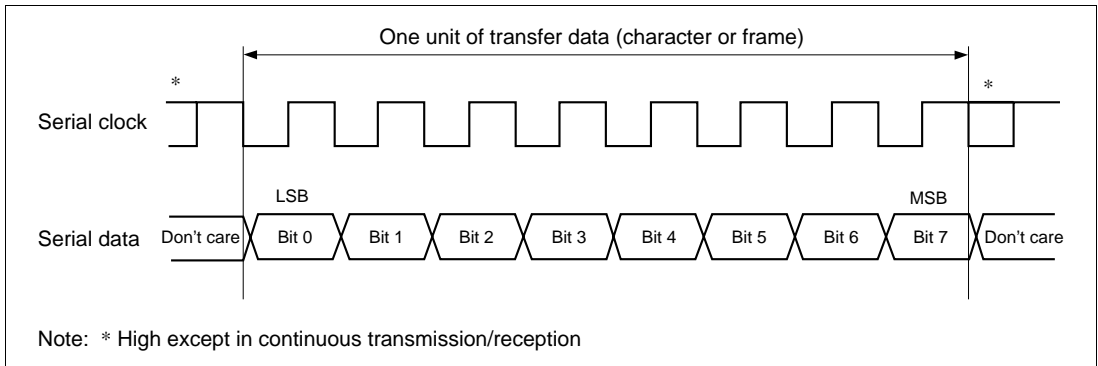

**Figure 14.16 Data Format in Synchronous Communication
(Example of LSB-First Transfer)**

In synchronous serial communication, data on the communication line is output from one fall of the serial clock to the next. Data is guaranteed valid at the rise of the serial clock.

In serial communication, each character is output starting with the LSB and ending with the MSB, or vice versa, according to the setting of the TLM bit in the serial status 2 register (SC2SSR). After the last data is output, the communication line remains in the state of the last data.

In synchronous mode, the SCIF receives data in synchronization with the fall of the serial clock.

Transmit/Receive Format: A fixed 8-bit data format is used. No parity or multiprocessor bits are added.

Clock: Either an internal clock generated by the built-in baud rate generator or an external serial clock input at the SCK pin can be selected, according to the setting of the C/\bar{A} bit in SCSMR and the CKE1 and CKE0 bits in SCSCR. For details of SCIF clock source selection, see table 14.9.

When the SCIF is operated on an internal clock, the serial clock is output from the SCK pin.

Eight serial clock pulses are output in the transfer of one character, and when no transmission/reception is performed the clock is fixed high. In receive-only operation, however, the SCIF receives two characters as one unit, and so a 16-pulse serial clock is output. To perform single-character receive operations, an external clock should be selected as the clock source.

Transmit/Receive Operations

- SCIF Initialization (Synchronous Mode)

Before transmitting and receiving data, it is necessary to clear the TE and RE bits to 0 in the serial control register (SCSCR), then initialize the SCIF as described below.

When the operating mode, communication format, etc., is changed, the TE and RE bits must be cleared to 0 before making the change using the following procedure. When the TE bit is cleared to 0, the TDFE flag is set to 1 and the transmit shift register (SCTSR) is initialized.

Note that clearing the RE bit to 0 does not change the contents of the RDF, PER, FER, and ORER flags, or the receive FIFO data register (SCFRDR).

Figure 14.17 shows a sample SCIF initialization flowchart.

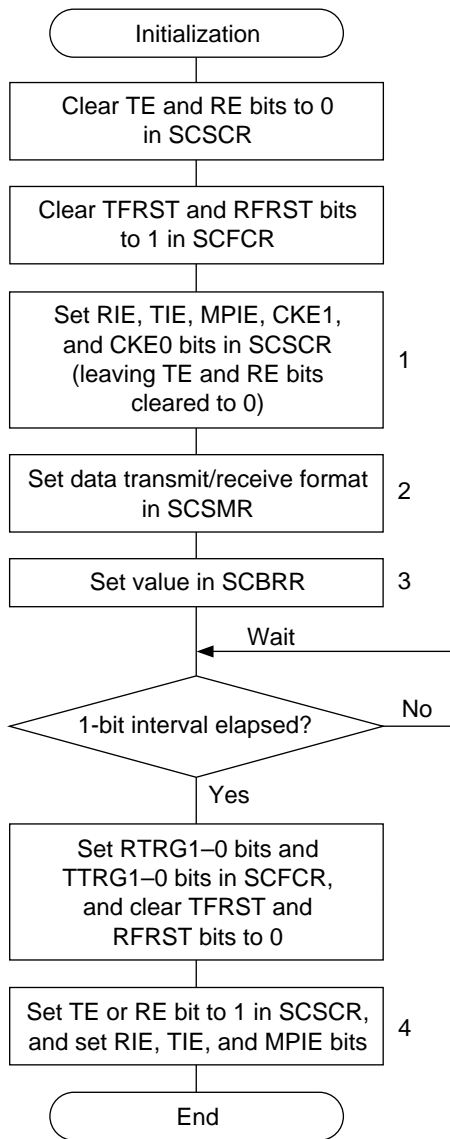

1. Set the clock selection in SCSCR. Be sure to clear bits RIE, TIE, MPIE, TE, and RE to 0.
2. Set the transmit/receive format in the serial mode register (SCSMR).
3. Write a value corresponding to the bit rate into the bit rate register (SCBRR). (Not necessary if an external clock is used.)
4. Wait at least one bit interval, then set the TE bit or RE bit to 1 in SCSCR. Also set the RIE, TIE, and MPIE bits. Setting the TE and RE bits simultaneously enables the TxD and RxD pins to be used.

Figure 14.17 Sample SCIF Initialization Flowchart

- Serial Data Transmission (Synchronous Mode)

Figure 14.18 shows a sample flowchart for serial transmission.

Use the following procedure for serial data transmission after enabling the SCIF for transmission.

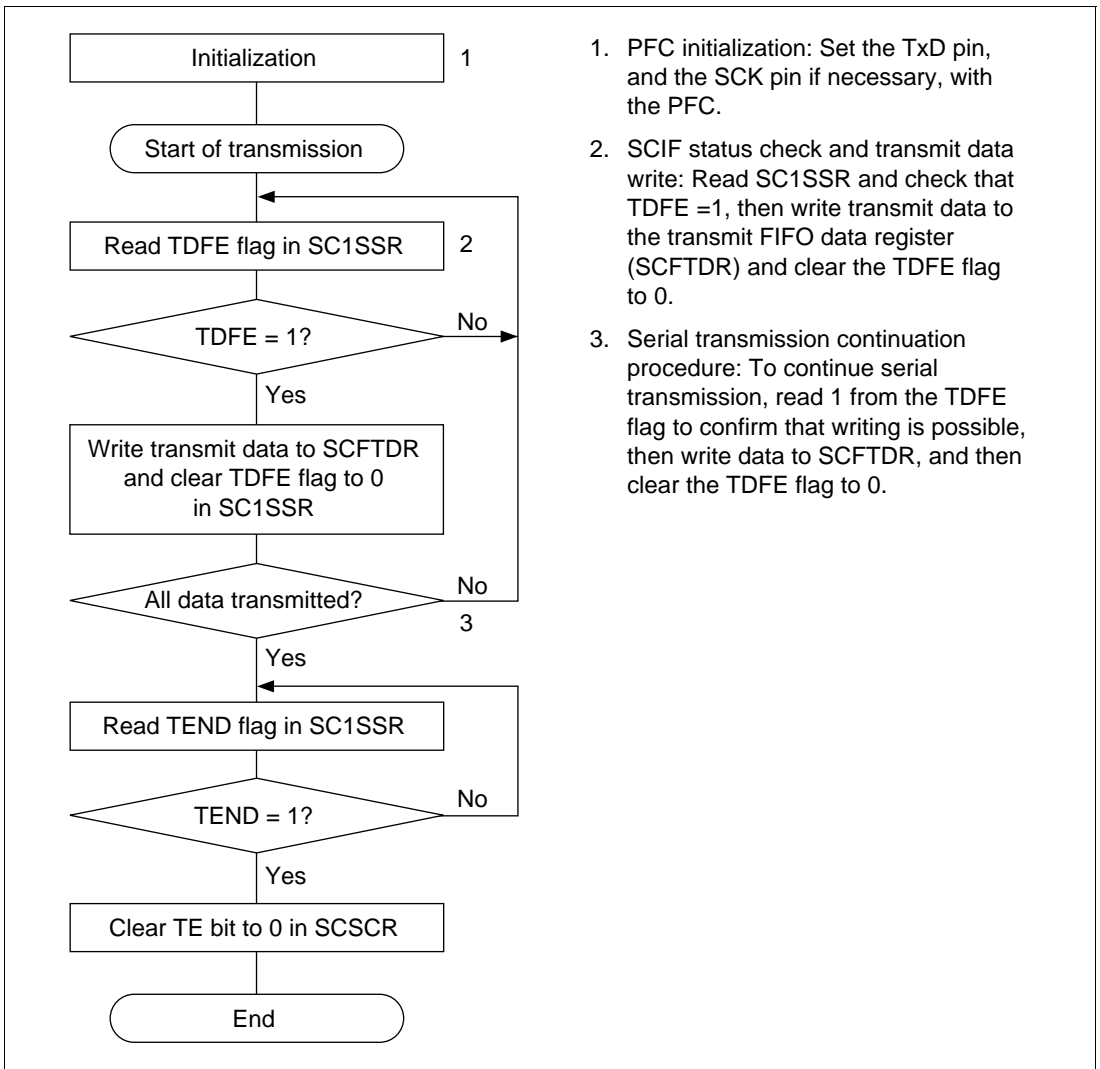

1. PFC initialization: Set the TxD pin, and the SCK pin if necessary, with the PFC.
2. SCIF status check and transmit data write: Read SC1SSR and check that TDFE =1, then write transmit data to the transmit FIFO data register (SCFTDR) and clear the TDFE flag to 0.
3. Serial transmission continuation procedure: To continue serial transmission, read 1 from the TDFE flag to confirm that writing is possible, then write data to SCFTDR, and then clear the TDFE flag to 0.

Figure 14.18 Sample Serial Transmission Flowchart

In serial transmission, the SCIF operates as described below.

1. When data is written to the transmit FIFO data register (SCFTDR), the SCIF transfers the data from SCFTDR to the transmit shift register (SCTSR), and starts transmitting. Check that the TDFE flag is set to 1 in the serial status 1 register (SC1SSR) before writing transmit data to SCFTDR. The number of data bytes that can be written is at least { 16 – (transmit trigger set number)}.
2. When data is transferred from SCFTDR to SCTSR and transmission is started, transmit operations are performed continually until there is no transmit data left in SCFTDR. If the number of data bytes in SCFTDR falls to or below the transmit trigger number set in the FIFO control register (SCFCR) during transmission, the TDFE flag is set. If the TIE bit setting in the serial control register (SCSCR) is 1 at this time, a transmit-FIFO-data-empty interrupt (TXI) is requested.

When clock output mode has been set, the SCIF outputs eight serial clock pulses for one unit of data.

When use of an external clock has been specified, data is output in synchronization with the input clock.

The serial transmit data is sent from the TxD pin starting with the LSB (bit 0) or MSB (bit 7) according to the setting of the TLM bit in the serial status 2 register (SC2SSR).

3. The SCIF checks for transmit data in SCFTDR at the timing for sending the last bit. If there is transmit data in SCFTDR, it is transferred to SCTSR and then serial transmission of the next frame is started. If there is no transmit data in SCFTDR, the TEND flag is set to 1 in the serial status 1 register (SC1SSR), the last bit is sent, and then the transmit data pin (TxD) holds its state.
4. After completion of serial transmission, the SCK pin is fixed high.

Figure 14.19 shows an example of SCIF operation in transmission.

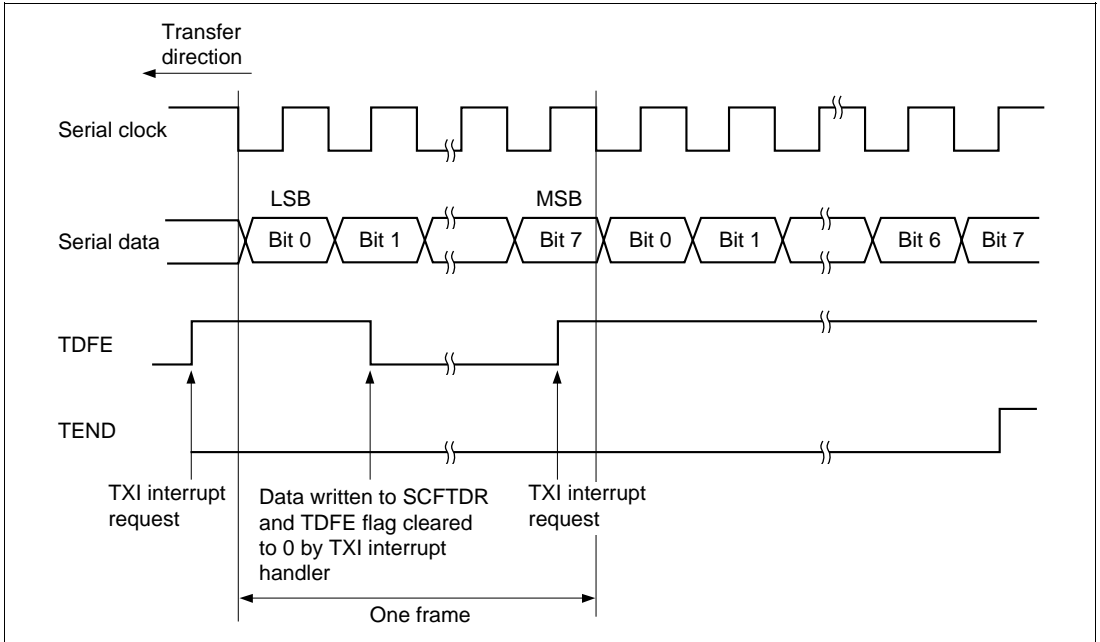
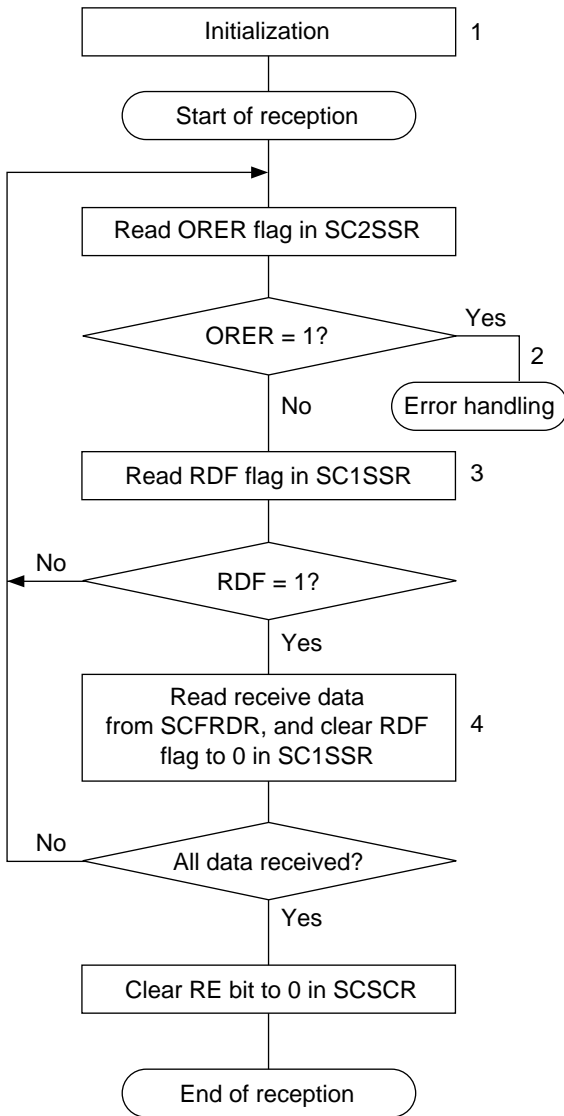

Figure 14.19 Example of SCIF Transmit Operation (Example of LSB-First Transfer)

- Serial Data Reception (Synchronous Mode)

Figure 14.20 shows a sample flowchart for serial reception.

Use the following procedure for serial data reception after enabling the SCIF for reception. When changing the operating mode from asynchronous to synchronous without resetting SCFRDR and SCFTDR by means of SCIF initialization, be sure to check that the ORER, PER3 to PER0, and FER3 to FER0 flags are all cleared to 0. The RDF flag will not be set if any of flags FER3 to FER0 or PER3 to PER0 are set to 1, and neither transmit nor receive operations will be possible.



1. PFC initialization: Set the RxD pin, and the SCK pin if necessary, with the PFC.
2. Receive error handling: If a receive error occurs, read the ORER flag in SC2SSR, and after performing the appropriate error handling, clear the ORER flag to 0. Transmission/reception cannot be resumed if the ORER flag is set to 1.
3. SCIF status check and receive data read: Read the serial status 1 register (SC1SSR) and check that RDF = 1, then read receive data from the receive FIFO data register (SCFRDR) and clear the RDF flag to 0. Transition of the RDF flag from 0 to 1 can also be identified by an RXI interrupt.
4. Serial reception continuation procedure: To continue serial reception, read at least the receive trigger set number of data bytes from SCFRDR, and write 0 to the RDF flag after reading 1 from it. The number of receive data bytes in SCFRDR can be ascertained by reading the lower 8 bits of the FIFO data count register (SCFDR). (The RDF bit is cleared automatically when the DMAC is activated by an RXI interrupt and the SCFRDR value is read.)

Figure 14.20 Sample Serial Reception Flowchart (1)

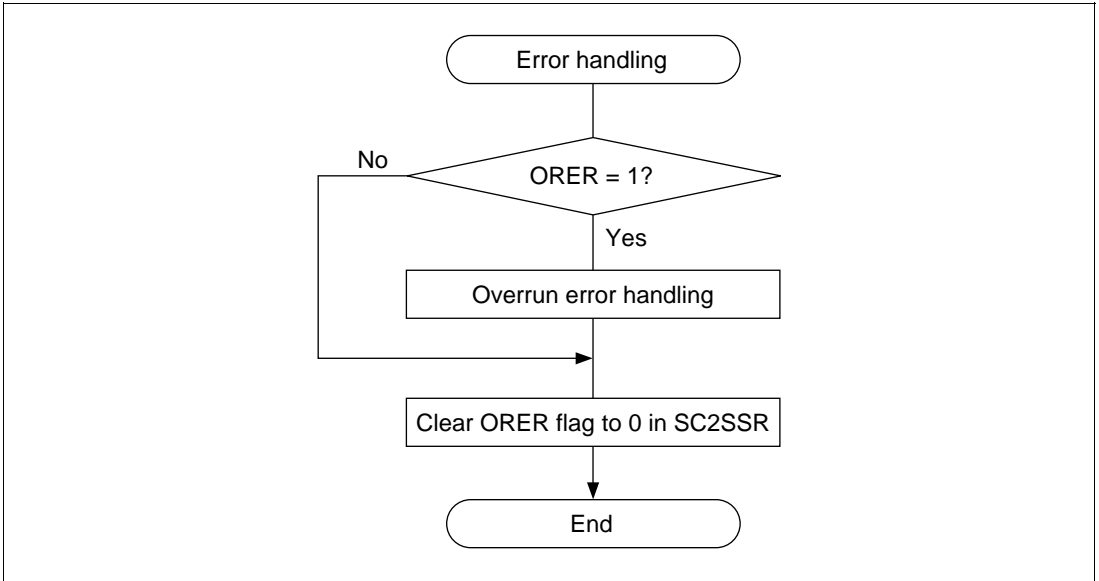

Figure 14.20 Sample Serial Reception Flowchart (2)

In serial reception, the SCIF operates as described below.

1. The SCIF performs internal initialization in synchronization with serial clock input or output.
2. The received data is stored in the receive shift register (SCRSR) in LSB-to-MSB order or MSB-to-LSB order according to the setting of the RLM bit in SC2SSR.

After reception, the SCIF checks whether the receive data can be transferred from SCRSR to the receive FIFO data register (SCFRDR). If this check is passed, the receive data is stored in SCFRDR.

If a receive error is detected in the error check, the operation is as shown in table 14.11.

Neither transmit nor receive operations can be performed subsequently when a receive error has been found in the error check.

Also, as the RDF flag is not set to 1 when receiving, the flag must be cleared to 0.

3. If the RIE bit setting in the serial control register (SCSCR) is 1 when the RDF flag is set to 1, a receive-FIFO-data-full interrupt (RXI) is requested. If the RIE bit setting in SCRSR is 1 when the ORER flag is set to 1, a receive-error interrupt (ERI) is requested.

Figure 14.21 shows an example of SCIF operation in reception.

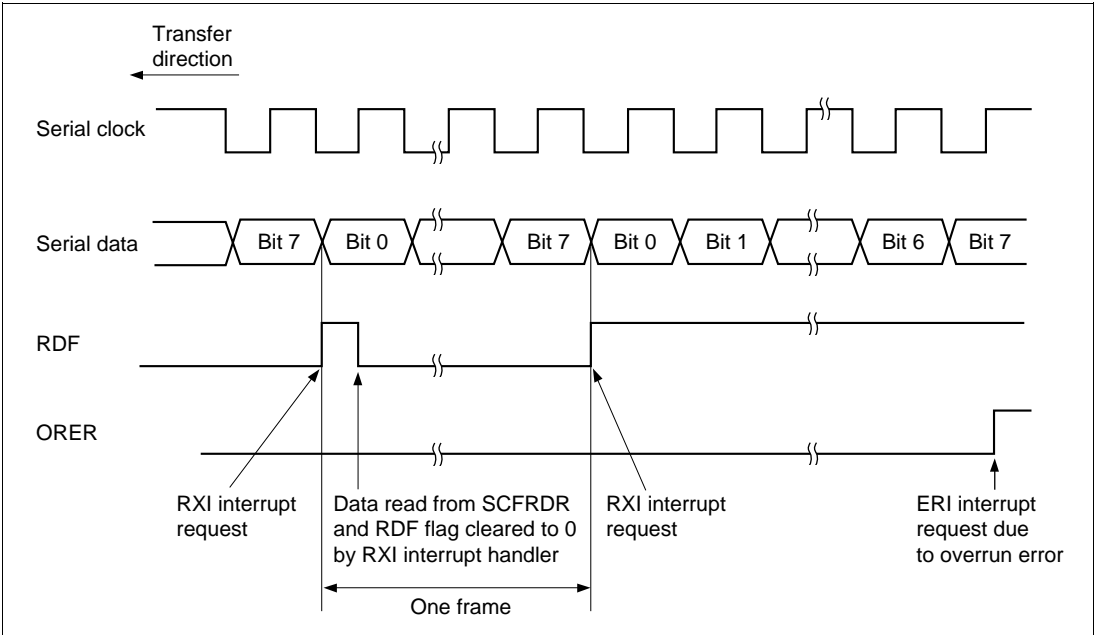
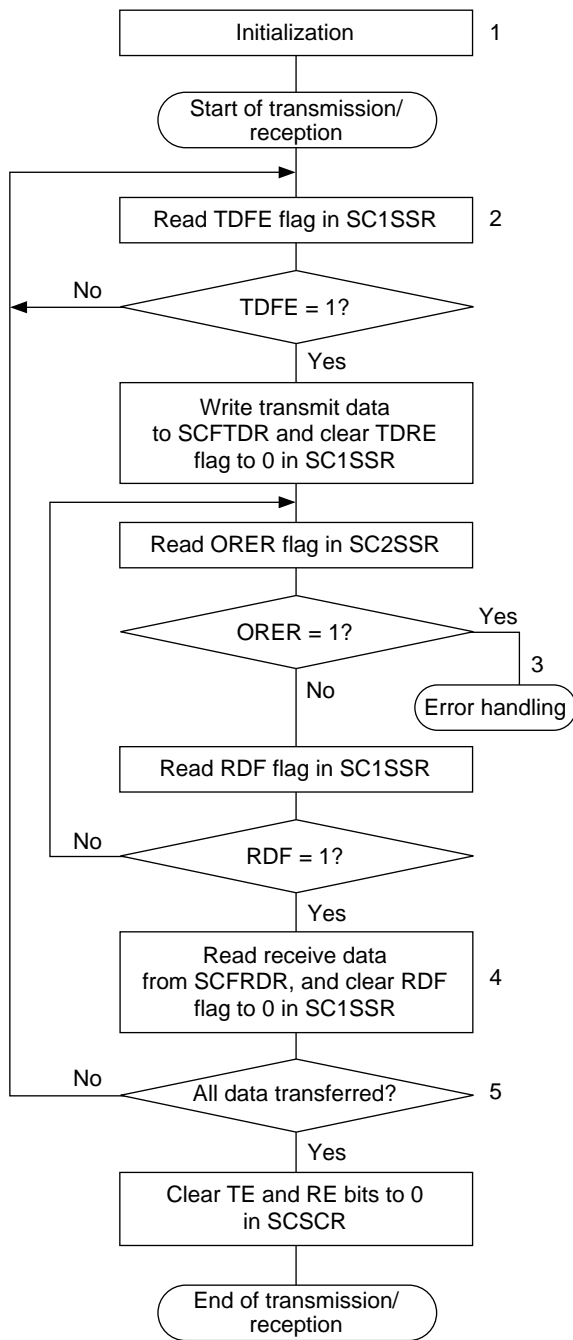

Figure 14.21 Example of SCIF Receive Operation (Example of LSB-First Transfer)

- **Simultaneous Serial Data Transmission and Reception (Synchronous Mode)**

Figure 14.22 shows a sample flowchart for simultaneous serial transmit and receive operations. Use the following procedure for simultaneous serial data transmit and receive operations after enabling the SCIF for transmission and reception.



1. PFC initialization: Set the TxD and RxD pins, and the SCK pin if necessary, with the PFC.
2. SCIF status check and transmit data write: Read SC1SSR and check that the TDFE flag is set to 1, then write transmit data to SCFTDR and clear the TDFE flag to 0. Transition of the TDFE flag from 0 to 1 can also be identified by a TXI interrupt.
3. Receive error handling: If a receive error occurs, read the ORER flag in SC2SSR, and after performing the appropriate error handling, clear the ORER flag to 0. Transmission/reception cannot be resumed if the ORER flag is set to 1.
4. SCIF status check and receive data read: Read SC1SSR and check that the RDF flag is set to 1, then read receive data from SCFRDR and clear the RDF flag to 0. Transition of the RDF flag from 0 to 1 can also be identified by an RXI interrupt.
5. Serial transmission/reception continuation procedure: To continue serial transmission/reception, finish reading the RDF flag, reading SCFRDR, and clearing the RDF flag to 0, before the MSB (bit 7) of the current frame is received. Also, before the MSB (bit 7) of the current frame is transmitted, read 1 from the TDFE flag to confirm that writing is possible, then write data to SCFTDR and clear the TDFE flag to 0.

Note: When switching from transmitting or receiving to simultaneous transmitting and receiving, first clear the TE bit and RE bit to 0, then set the TE bit and RE bit to 1 simultaneously.

Figure 14.22 Sample Flowchart for Serial Data Transmission and Reception

14.3.5 Use of Transmit/Receive FIFO Buffers

The SCIF has independent 16-stage FIFO buffers for transmission and reception. The configuration of these buffers is shown in figure 14.23.

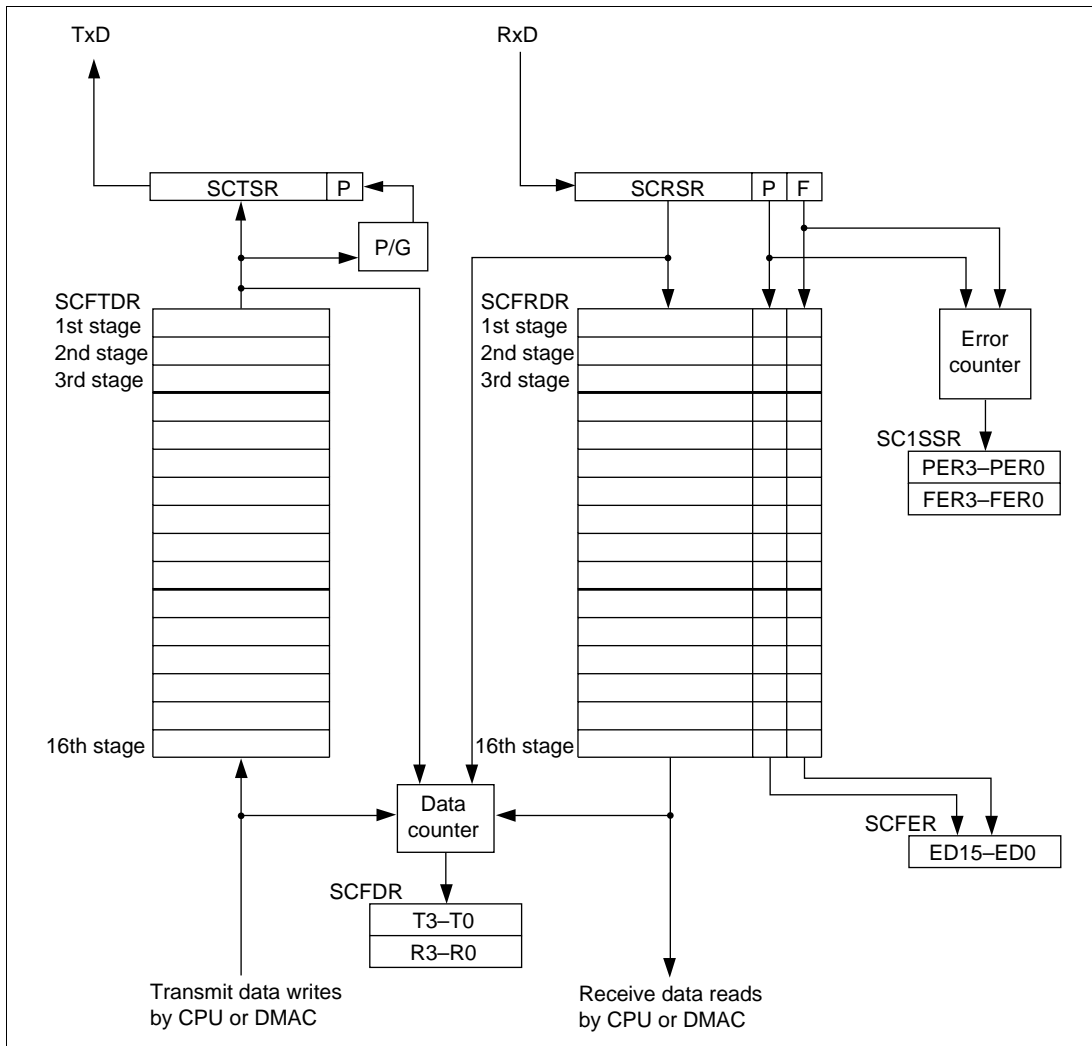

Figure 14.23 Transmit/Receive FIFO Configuration

In Serial Data Transmit Operations: In transmission, when transmit data is written to the transmit FIFO by the CPU or DMAC and the TE bit is set to 1 in the serial control register (SCSCR), the data is first transferred to the transmit shift register (SCTSR) in the order of writing to the transmit FIFO, a parity bit is added by the parity generator (P/G), and then serial data is transmitted from the TxD pin.

Each time data is written into the transmit FIFO, the value in bits T4 to T0 in the FIFO data count register (SCFDR) is incremented, and each time data is transferred to SCTSR the value in bits T4 to T0 is decremented. The current number of data bytes in the transmit FIFO can thus be found by reading bits T4 to T0 in SCFDR.

A value of H'10 in bits T4 to T0 means that data has been written into all 16 stages of the transmit FIFO. If additional data is written to the FIFO in this state, bits T4 to T0 will not be incremented and the written data will be lost.

When the transmit trigger number is set and transmit data is written to the FIFO by the DMAC, care must be taken not to write data exceeding the number of empty bytes in SCFTDR indicated by the FIFO control register (SCFCR) (see section 14.2.10).

In Serial Data Receive Operations: In reception, serial data input from the RxD pin is first captured in the receive shift register (SCRSR) in the order specified by the RLM bit in the serial status 2 register (SC2SSR). A parity bit check is carried out, and if there is a parity error the P (parity error) flag for that data is set to 1. A stop bit check is also performed, and if a framing error is found the F (framing error) flag for that data is set to 1. The receive FIFO buffer has a 10-bit configuration, with the P and F flags for each 8-bit data unit stored together with that data.

- **Receive FIFO Control in Normal Operation**

Receive data held in the receive FIFO buffer is read by the CPU or DMAC.

Each time data is transferred from SCRSR to the receive FIFO, the value in bits R4 to R0 in SCFDR is incremented, and each time the CPU or DMAC reads receive data from the receive FIFO, the value in bits R4 to R0 is decremented. The current number of data bytes in the receive FIFO can thus be found by reading bits R4 to R0 in SCFDR.

A value of H'10 in bits R4 to R0 means that receive data has been transferred to all 16 stages of the receive FIFO. If the next serial receive operation is completed before the CPU or DMAC reads data from the receive FIFO, an overrun error will result and the serial data will be lost. If receive FIFO data is read when the value of bits R4 to R0 is H'00, an undefined value will be returned.

- Receive FIFO Control in Error Data Reception

When data is transferred from SCRSR to the receive FIFO, the P and F flags are also transferred. If either of these flags is set to 1, the error counter is incremented and the corresponding bit (PER3 to PER0, FER3 to FER0) is updated in the serial status 1 register (SC1SSR). The error counter is decremented if the P or F flag is 1 when data in the receive FIFO is read by the CPU or DMAC. The settings of the P and F flags for the read receive data are also reflected in the PER and FER flags in SC1SSR. PER and FER are set when data containing a parity error or framing error is read from the receive FIFO; they are not set when serial data containing a parity error or framing error is received from the RxD pin. PER and FER are cleared when data with no parity error or framing error is read from the receive FIFO. This data is transferred to the receive FIFO even if it contains a parity error or framing error. Whether or not the receive operation is to be continued at this point can be specified with the EI bit in SC2SSR. If the EI bit is set to 1, specifying continuation of the receive operation, receive data is still transferred sequentially to the receive FIFO after an error occurs. The stage of the 16-stage FIFO buffer in which the data with the error is located can be determined by reading bits ED15 to ED0 in the FIFO error register (SCFER).

When the receive trigger number is set and receive data is read from the receive FIFO by the DMAC, care must be taken not to read data exceeding the receive trigger number indicated by the FIFO control register (SCFCR) (see section 14.2.10).

- Receive FIFO Control by DR Flag

When a number of data bytes equal to or exceeding the receive trigger number have been received, a receive data read request is issued to the CPU or DMAC by means of an RXI interrupt (RDF only). However, an RXI interrupt is not requested if all reception has been completed with fewer than the receive trigger number of data bytes having been received. In this case, the DR flag is set and an ERI interrupt is requested 16 etu after reception of the last data is completed. The CPU should therefore read bits R4 to R0 in SCFDR to find the number of data bytes left in the receive FIFO, and read all the data in the FIFO.

Note: With an 8-bit, 1-stop-bit format, one etu is equivalent to 1.6 frames.

etu: Elementary time unit = sec/bit

14.3.6 Operation in IrDA Mode

In IrDA mode, the waveform of TxD/RxD transmit/receive data is modified to comply with the IrDA 1.0 infrared communication specification. This makes it possible to carry out infrared transmission and reception conforming to the IrDA 1.0 standard by connecting an infrared transmission/reception transceiver/receiver.

In the IrDA 1.0 specification, communication is initially executed at 9600 bps, and then the transfer rate can be changed as required. However, the communication speed is not changed automatically in this module. When executing communication, therefore, it is necessary to check the communication speed and have the appropriate speed set in this module by software.

Note: In IrDA mode, reception is not possible when the TE bit is set to 1 (enabling communication) in the serial control register (SCSCR). When performing reception, the TE bit in SCSCR must be cleared to 0.

Transmission: In the case of a serial output signal (UART frame) from the SCIF, the waveform is corrected and the signal is converted to an IR frame serial output signal by the IrDA module as shown in figure 14.24.

When the serial data is 0, if the PSEL bit is 0 in the IrDA mode register (SCIMR) a pulse of 3/16 the IR frame bit width is generated and output, and if the PSEL bit is 1 a pulse of 3/16 the bit width of the bit rate set in bits ICK3 to 0 in the serial mode register (SCSMR) is generated and output. When the serial data is 1, a pulse is not output.

An infrared LED is driven by a signal demodulated to a 3/16 width.

Reception: Pulses of 3/16 the received IR frame bit width are converted to UART frames after demodulation as shown in figure 14.24.

Demodulation to 0 is executed for pulse output and demodulation to 1 when there is no pulse output.

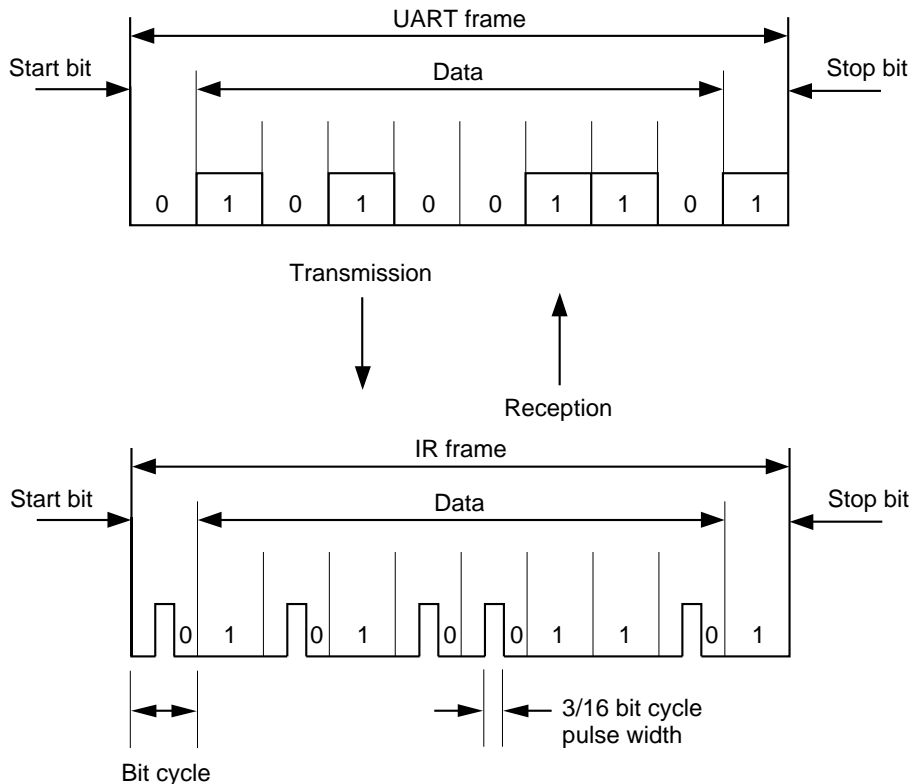

Figure 14.24 IrDA Mode Transmit/Receive Operations

Pulse Width Selection: In transmission, the IR frame pulse width can be selected as either $3/16$ of the transmission bit rate or a smaller pulse width by means of the PSEL bit in the IrDA mode register (SCIMR).

The SCIF includes a baud rate generator that generates the transmit frame bit rate and a baud rate generator that generates the IRCLK signal for varying the pulse width.

When the PSEL bit is cleared to 0 in SCIMR, a width of $3/16$ the bit rate set in the bit rate register (SCBRR) is output as the IR frame pulse width. As the pulse width is the direct infrared emission time; if the user wishes to minimize the pulse width in order to reduce power consumption, the PSEL bit should be set to 1 in SCIMR and a setting should also be made in bits ICK3 to ICK0 in the serial mode register (SCSMR) to generate the IRCLK signal, resulting in output with the minimum settable pulse width.

The minimum IR frame pulse width must be 3/16 of the 115.2 kbps bit rate (= 1.63 μsec). With this minimum pulse width, IRCLK = 921.6 kHz, and so the setting for bits ICK3 to ICK0 to give the minimum settable pulse width is given by the following equation.

$$N \geq \frac{P\phi}{2 \times \text{IRCLK}} - 1$$

Pφ: Operating clock frequency

IRCLK: 921.6 kHz (fixed)

N: Set value of ICK3 to ICK0 (0 ≤ N ≤ 15)

For example, when Pφ = 20 MHz, N = 10.

Table 14.12 shows the settings of bits ICK3 to ICK0 that can be used to obtain the minimum pulse width for various operating frequencies.

**Table 14.12 Bits ICK3 to ICK0 and Operating Frequencies in IrDA mode
(When PSEL = 1)**

Operating Frequency P ϕ (MHz)	Setting of Bits ICK3 to ICK0 in SCSMR			
	ICK3	ICK2	ICK1	ICK0
2	0	0	0	0
3				1
5			1	0
6				1
8		1	0	0
10				1
12			1	0
14				1
16	1	0	0	0
18				1
20			1	0
21				1
22				1
23		1	0	0
24				1
25				1
26			1	0
27				0
28				1

14.4 SCIF Interrupt Sources and the DMAC

The SCIF has four interrupt sources: the break interrupt (BRI) request, receive-error interrupt (ERI) request, receive-FIFO-data-full interrupt (RXI) request, and transmit-FIFO-data-empty interrupt (TXI) request.

Table 14.13 shows the interrupt sources and their relative priorities. The interrupt sources can be enabled or disabled with the TIE or RIE bit in SCSCR. Each kind of interrupt request is sent to the interrupt controller independently.

When the TDFE flag is set to 1 in the serial status 1 register (SC1SSR), a TXI interrupt is requested. A TXI interrupt request can activate the DMAC to perform data transfer. The TDFE bit is cleared to 0 automatically when all writes to the transmit FIFO data register (SCFTDR) by the DMAC are completed.

When the RDF flag is set to 1 in SC1SSR, an RXI interrupt is requested. An RXI interrupt request can activate the DMAC to perform data transfer. The RDF bit is cleared to 0 automatically when all receive FIFO data register (SCFRDR) reads by the DMAC are completed.

When the ER flag is set to 1, an ERI interrupt is requested. The DMAC cannot be activated by an ERI interrupt request.

When the BRK flag is set to 1, a BRI interrupt is requested. The DMAC cannot be activated by a BRI interrupt request.

A TXI interrupt indicates that transmit data can be written, and an RXI interrupt indicates that there is receive data in SCFRDR.

Table 14.13 SCIF Interrupt Sources

Interrupt Source	Description	DMAC Activation	Priority on Reset Release
ERI	Receive error (ER)	Not possible	High
RXI	Receive data full (RDF) or data ready (DR)	Possible (RDF only)	↑
BRI	Break (BRK)	Not possible	↓
TXI	Transmit data FIFO empty (TDFE)	Possible	Low

14.5 Usage Notes

The following points should be noted when using the SCIF.

SCFTDR Writing and the TDFE Flag: The TDFE flag in the serial status 1 register (SC1SSR) is set when the number of transmit data bytes written in the transmit FIFO data register (SCFTDR) has fallen to or below the transmit trigger number set by bits TTRG1 and TTRG0 in the FIFO control register (SCFCR). After TDFE is set, transmit data up to the number of empty bytes in SCFTDR can be written, allowing efficient continuous transmission.

However, if the number of data bytes written in SCFTDR is equal to or less than the transmit trigger number, the TDFE flag will be set to 1 again after being read as 1 and cleared to 0. TDFE clearing should therefore be carried out when SCFTDR contains more than the transmit trigger number of transmit data bytes.

The number of transmit data bytes in SCFTDR can be found from the upper 8 bits of the FIFO data count register (SCFDR).

Simultaneous Multiple Receive Errors: If a number of receive errors occur at the same time, the state of the status flags in SC1SSR and SC2SSR is as shown in table 14.14. If there is an overrun error, data is not transferred from the receive shift register (SCRSR) to the receive FIFO data register (SCFRDR), and the receive data is lost.

Table 14.14 SC1SSR/SC2SSR Status Flags and Transfer of Receive Data

Receive Errors	SC1SSR/SC2SSR Status Flags				Receive Data Transfer SCRSR → SCFRDR
	RDF	ORER	FER	PER	
Overrun error	1	1	0	0	×
Framing error	0	0	1	0	○
Parity error	0	0	0	1	○
Overrun error + framing error	1	1	1	0	×
Overrun error + parity error	1	1	0	1	×
Framing error + parity error	0	0	1	1	○
Overrun error + framing error + parity error	1	1	1	1	×

Notes: ○: Receive data is transferred from SCRSR to SCFRDR.

×: Receive data is not transferred from SCRSR to SCFRDR.

Break Detection and Processing: Break signals can be detected by reading the RxD pin directly when a framing error (FER) is detected. In the break state the input from the RxD pin consists of all 0s, so the FER flag is set and the parity error flag (PER) may also be set.

Note that although the SCIF stops transferring receive data to SCFRDR after receiving a break, the receive operation continues, so if the FER and BRK flags are cleared to 0 they will be set to 1 again.

Sending a Break Signal: The TxD pin is a general I/O pin whose input/output direction and level are determined by the I/O port data register (DR) and the control register (CR) of the pin function controller (PFC). This fact can be used to send a break signal.

The DR value substitutes for the mark state until the PFC setting is made. The initial setting should therefore be as an output port outputting 1.

To send a break signal during serial transmission, clear DR, then set the TxD pin as an output port with the PFC.

When the TE bit is cleared to 0, the transmitter is initialized regardless of the current transmission state.

Receive Error Flags and Transmit Operations (Synchronous Mode Only): Transmission cannot be started when any of the receive error flags (ORER, PER3 to PER0, FER3 to FER0) is set to 1, even if the TDFE flag is set to 1. Be sure to clear the receive error flags to 0 before starting transmission.

Note also that the receive error flags are not cleared to 0 by clearing the RE bit to 0.

Receive Data Sampling Timing and Receive Margin in Asynchronous Mode: In asynchronous mode, the SCIF operates on a base clock with a frequency of 16, 8, or 4 times the transfer rate.

In reception, the SCIF synchronizes internally with the fall of the start bit, which it samples on the base clock. Receive data is latched at the rising edge of the eighth, fourth, or second base clock pulse. The timing is shown in figure 14.25.

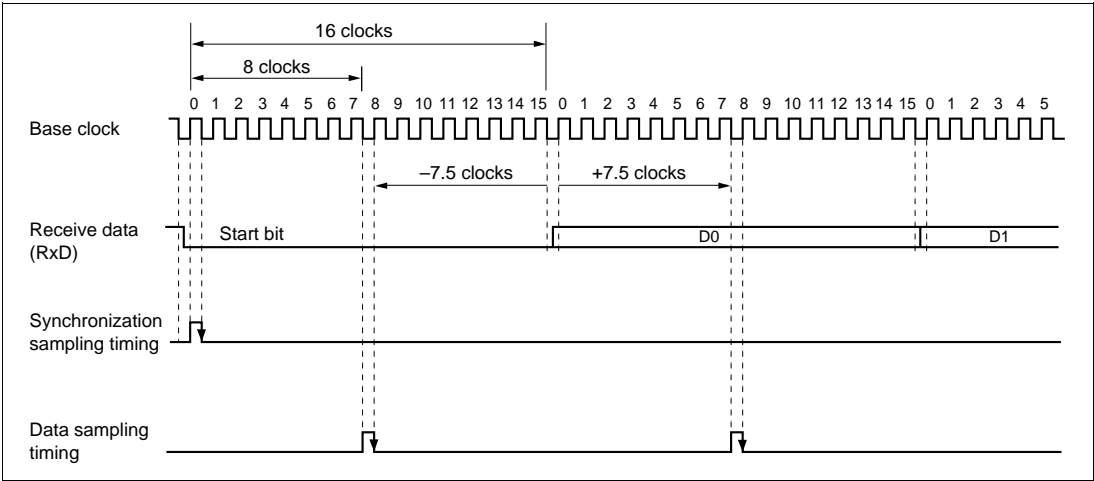

Figure 14.25 Receive Data Sampling Timing in Asynchronous Mode
(Using base clock with frequency of 16 times the transfer rate, sampled in 8th clock cycle)

The receive margin in asynchronous mode can therefore be expressed as shown in equation (1).

$$M = \left[\left(0.5 - \frac{1}{2N} \right) - (L - 0.5) F - \frac{|D - 0.5|}{N} (1 + F) \right] \times 100\% \quad \dots\dots\dots (1)$$

- M: Receive margin (%)
- N: Ratio of clock frequency to bit rate (N = 16, 8, or 4)
- D: Clock duty cycle (D = 0 to 1.0)
- L: Frame length (L = 9 to 12)
- F: Absolute deviation of clock frequency

From equation (1), if F = 0 and D = 0.5, the receive margin is 46.875%, as given by equation (2).

When D = 0.5, F = 0, and N = 16:

$$M = (0.5 - 1/(2 \times 16)) \times 100\% = 46.875\% \dots\dots\dots (2)$$

This is a theoretical value. A reasonable margin to allow in system designs is 20% to 30%.

When Using Synchronous External Clock Mode

- Do not set TE or RE to 1 until at least 4 peripheral operating clock cycles after external clock SCK has changed from 0 to 1.
- Only set both TE and RE to 1 when external clock SCK is 1.
- In reception, note that if RE is cleared to 0 from 2.3 to 3.5 peripheral operating clock cycles after the rising edge of the RxD D7 bit SCK input, RDF will be set to 1 but copying to SCFRDR will not be possible.

When Using Synchronous Internal Clock Mode: In reception, note that if RE is cleared to zero 1.5 peripheral operating clock cycles after the rising edge of the RxD D7 bit SCK output, RDF will be set to 1 but copying to SCFRDR will not be possible.

When Using the DMAC: When an external clock source is used as the serial clock, the transmit clock should not be input until at least 5 P ϕ clock cycles after SCFTDR is updated by the DMAC. Incorrect operation may result if the transmit clock is input within 4 P ϕ cycles after SCFTDR is updated. (See figure 14.26.)

When performing SCFRDR reads by the DMAC, be sure to set the relevant SCIF receive-FIFO-data-full interrupt (RXI) as an activation source.

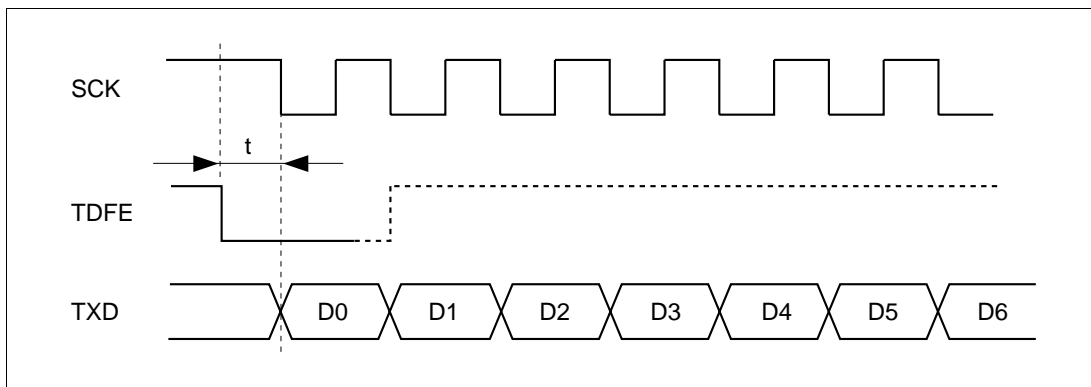

Figure 14.26 Example of Synchronous Transmission by DMAC

SCFRDR Reading and the RDF Flag: The RDF flag in the serial status 1 register (SC1SSR) is set when the number of receive data bytes in the receive FIFO data register (SCFRDR) has become equal to or greater than the receive trigger number set by bits RTRG1 and RTRG0 in the FIFO control register (SCFCR). After RDF is set, receive data equivalent to the trigger number can be read from SCFRDR, allowing efficient continuous reception.

However, if the number of data bytes in SCFRDR is equal to or greater than the trigger number, the RDF flag will be set to 1 again if it is cleared to 0. RDF should therefore be cleared to 0 after being read as 1 after receive data has been read to reduce the number of data bytes in SCFRDR to less than the trigger number.

The number of receive data bytes in SCFRDR can be found from the lower 8 bits of the FIFO data count register (SCFDR).

SCFRDR Reading when Overrun Occurs: If a receive operation is continued despite the fact that the receive FIFO data register (SCFRDR) contains 16 bytes of data, overrun will occur.

If SCFRDR is read in this state, the data that caused the overrun is read in the 17th read. The value returned in the 18th and subsequent reads will be undefined.

Also note that, from the first SCFRDR read onward, the number of receive data bytes in SCFRDR indicated by the lower 8 bits of the FIFO data count register (SCFDR) is one more than the actual number of receive data bytes.

Section 15 Serial I/O with FIFO (SIOF)

15.1 Overview

The serial I/O with FIFO functions mainly as an interface between the chip and a codec or modem analog front-end.

15.1.1 Features

The serial I/O has the following features:

- Full-duplex operation
Independent transmit/receive registers and independent transmit/receive clocks
- Primary data transmit/receive FIFO/Double-buffered transmit/receive ports
Continuous data transmission/reception possible
- Interval transfer mode and continuous transfer mode
- Memory-mapped receive data register, transmit data register, serial control register, and serial status register, receive control data register, transmit control data register, FIFO control register, FIFO data count register
With the exception of SIRSRSR and SITSR, these registers are memory-mapped and can be accessed by a MOV instruction.
- Choice of 8- or 16-bit data length
- Data transfer communication by means of polling or interrupts
Data transfer can be monitored by polling the receive data register full flag (RDRF), the receive data register empty flag (RDRE), the receive control data register full flag (RCD), and the transmit control data register empty flag (TCD). Interrupt requests can be generated during data transfer by setting the receive interrupt request flag and the transmit interrupt request flag.
- Either MSB-first or LSB transfer can be selected for data I/O operations.

Figure 15.1 shows a block diagram of the serial I/O with FIFO.

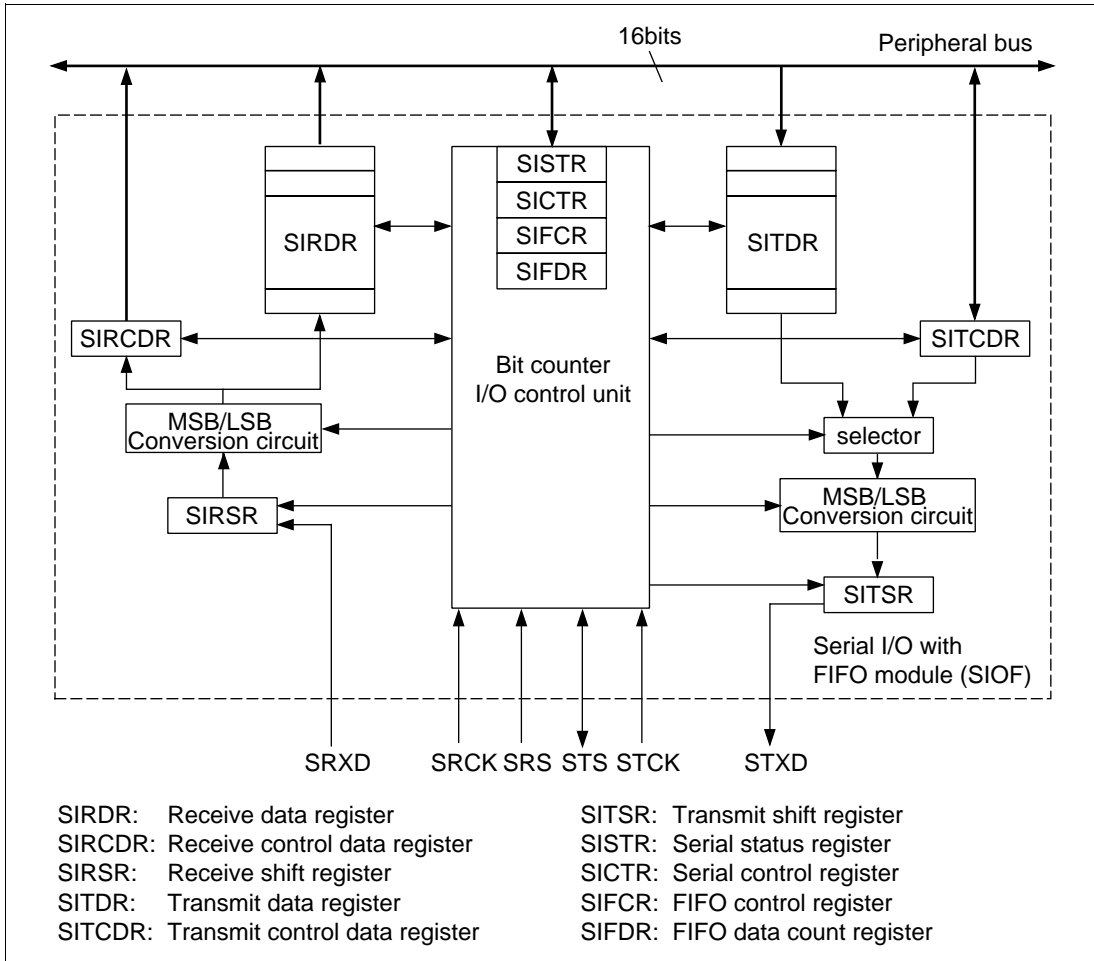

Figure 15.1 SIOF Block Diagram

Table 15.1 shows the functions of the external pins.

Table 15.1 Serial I/O with FIFO (SIOF) External Pins

Name	Pin	I/O	Function
Serial receive data input pin	SRxD0	Input	Serial data input port
Serial receive clock input pin	SRCK0	Input	Serial receive clock port
Serial reception synchronization input pin	SRS0	Input	Serial reception synchronization input port
Serial transmit data output pin	STxD0	Output	Serial data output port
Serial transmit clock input pin	STCK0	Input	Serial transmit clock port
Serial transmission synchronization input/output pin	STS0	I/O	Serial transmission synchronization input/output port

15.2 Register Configuration

Table 15.2 shows the SIOF's registers.

Table 15.2 Register Configuration

Register	Abbreviation	R/W	Initial Value	Address	Access Size (Bits)
Receive shift register	SIRSR0	—	—	—	—
Receive data register	SIRDRO	R	Not specified	H'FFFFFFC00	8, 16, 32
Transmit shift register	SITSR0	—	—	—	—
Transmit data register	SITDR0	R/W	H'0000	H'FFFFFFC02	8, 16, 32
Serial control register	SICTR0	R/W	H'0000	H'FFFFFFC04	8, 16, 32
Serial status register	SISTR0	R/(W)*	H'0002	H'FFFFFFC06	8, 16, 32
Receive control data register	SIRCDR	R	H'0000	H'FFFFFFC0C	8, 16, 32
Transmit control data register	SITCDR	R/W	H'0000	H'FFFFFFC0E	8, 16, 32
FIFO control register	SIFCR	R/W	H'0000	H'FFFFFFC08	8, 16, 32
FIFO data count register	SIFDR	R	H'0000	H'FFFFFFC0A	8, 16, 32

Note: * Only 0 should be written, to clear flags (after reading 1 from the flag).

15.2.1 Receive Shift Register (SIRSR)

Bit:	15	14	13	...	3	2	1	0
	<input type="text"/>	<input type="text"/>	<input type="text"/>	...	<input type="text"/>	<input type="text"/>	<input type="text"/>	<input type="text"/>
Initial value:	—	—	—	...	—	—	—	—
R/W:	—	—	—	...	—	—	—	—

SIRSR is a 16-bit register used to receive serial data. The data is fetched in MSB first from the SRxD pin in synchronization with the fall of the serial receive clock (SRCK), and is shifted into SIRSR. The data length is set by the transmit/receive data length select bit (DL) in the corresponding serial control register (SICTR). If the DL bit is cleared to 0 (data length 8 bits), the receive data is fetched to the lower 8 bits, and the upper 8 bits are cleared to 0. When data transfer to SIRSR is completed, the data contents are automatically transferred to the receive data register (SIRDRO), and the receive data register full flag (RDRF) is set in the serial status register (SISTR), based on the settings of the receive FIFO watermark bits (RFWM3 to RFWM0) in SIFCR.

When transfer of control data to SIRSR is completed, the data contents are automatically

transferred to the receive control data register (SIRCDR), and the receive control data register full flag (RCD) is set in SISTR.

If the next data word input operation ends before the RDRF flag is cleared, an overrun error occurs, the receive overrun error flag (RERR) is set in SISTR, and an overrun error signal is sent to the interrupt controller (INTC). The data in SIRSR overwrites the data in SIRDR.

If SIRCDR contains valid control data, SIRCDR is overwritten after the next control data input operation completes.

15.2.2 Receive Data Register (SIRDR)

Bit:	15	14	13	...	3	2	1	0
				...				
Initial value:	0	0	0	...	0	0	0	0
R/W:	R	R	R	...	R	R	R	R

SIRDR is a 16-bit x 16-stage FIFO register that stores primary receive data. When primary data is transferred from SIRSR to SIRDR, the receive data register full flag (RDRF) is set in the serial status register (SISTR), based on the settings of RFWM3 to RFWM0 in SIFCR. If the receive interrupt enable flag (RIE) is set in SICTR, a receive-data-full interrupt (RDFI) request is sent to the interrupt controller (INTC) and the DMA controller (DMAC). When the flag is cleared, this interrupt request signal is not generated. When SIRDR is read by the DMAC, the RDRF flag is cleared automatically if the value is less than or equal to the setting of bits RFWM3 to RFWM0 in SIFCR. When SIRDR is reset, its status is empty. The status of SIRDR is also empty when the value of the receive FIFO data registry reset bit (RFRST) in SIFCR is 1.

Note: Do not read from SIRDR when it contains no primary receive data (when the value of the receive data register data count bits 4 to 0 (R4 to R0) in the FIFO data count register (SIFDR) is 00000).

15.2.3 Transmit Shift Register (SITSR)

Bit:	15	14	13	...	3	2	1	0
				...				
Initial value:	—	—	—	...	—	—	—	—
R/W:	—	—	—	...	—	—	—	—

SITSR is a 16-bit register used to transmit serial data. The contents of this register are shifted in MSB-first or LSB-first order, based on the LM bit in SIFCR, in synchronization with the rising edge of the serial transmit clock (STCK), and output from the serial transmit data STXD pin. The

transfer data length is set by the DL bit in SICTR. The transmit mode bit (TRMD) in SIFCR controls the LSB of the transmitted primary data or control data.

When the TRMD bit is cleared to 0 and the DL bit is cleared to 0 (8-bit data length), the lower 8 bits in the transmit data register (SITDR) are output. When the DL bit is set to 1 (16-bit data length), all 16 bits in SITDR are output.

Setting the TRMD bit to 1 causes the LSB of the primary data to be output as 0. Performing write access to the transmit control data register (SITCDR) in this case, if the DL bit is cleared to 0, causes the lower 8 bits in SITDR to be output, with the LSB as 1, after which the lower 8 bits in SITCDR are output. If the DL bit is set to 1, all 16 bits in SITDR are output, with the LSB as 1, after which all 16 bits in SITCDR are output.

When transmit primary data with a value less than or equal to the transmit FIFO watermark bits (TFWM3 to TFWM0) in SIFCR is transferred from SITDR to SITSR, the transmit data register empty flag (TDRE) is set in SISTR. If output of the next primary data begins when the amount of transmit primary data in SITDR is 0, an underrun error occurs, the transmit underrun error flag (TERR) in SISTR is set, and an error interrupt request is sent to the INTC.

15.2.4 Transmit Data Register (SITDR)

Bit:	15	14	13	...	3	2	1	0
				...				
Initial value:	0	0	0	...	0	0	0	0
R/W:	W	W	W	...	W	W	W	W

SITDR is a 16-bit x 16-stage FIFO register that stores primary transmit data. Data should be written to SITDR when the transmit data register empty flag (TDRE) is set to 1 in SISTR. If data is written to SITDR when TDRE is 0, a SITDR overflow may occur. When transmit primary data with a value less than or equal to the setting of TFWM3 to TFWM0 in SIFCR is transferred from SITDR to SITSR, TDRE is set in SISTR. If at this point the transmit interrupt enable flag (TIE) is set, a transmit-data-empty interrupt (TDEI) request is sent to the INTC and DMAC. If TIE is cleared, this interrupt request is not generated. When the DMAC writes to SITDR data with a value greater than the setting of TFWM3 to TFWM0 in SIFCR, the TDRE flag is cleared automatically. The TDRE flag is set only by hardware.

When SITDR is reset, its status is empty. The status of SITDR is also empty when the value of the transmit FIFO data registry reset bit (TFRST) in SITDR is 1.

Note: Do not write to SITDR when it is full of primary transmit data (when the value of the transmit data register data count bits 4 to 0 (T4 to T0) in SIFDR is 10000). Data should be written to SITDR in the size specified by the setting of the DL bit in SICTR. Always set the TE bit to 1 before writing to this register.

15.2.5 Serial Control Register (SICTR)

Bit:	15	14	13	12	11	10	9	8
	—	—	—	—	—	DMACE	TCIE	RCIE
Initial value:	0	0	0	0	0	0	0	0
R/W:	R	R	R	R	R	R/W	R/W	R/W
Bit:	7	6	5	4	3	2	1	0
	—	TM	SE	DL	TIE	RIE	TE	RE
Initial value:	0	0	0	0	0	0	0	0
R/W:	R	R/W	R/W	R/W	R/W	R/W	R/W	R/W

SICTR is a 16-bit register used to set parameters for serial port control. SICTR is initialized to H'0000 by a reset.

When modifying bit 4, 5, 6, or 10 (DMACE, TM, SE, or DL), TE and RE (bit 1, 0) should be cleared to 0 beforehand.

Bits 15 to 11—Reserved: These bits are always read as 0. The write value should always be 0.

Bit 10—DMAC Activation Enable (DMACE): Specifies whether the DMAC is activated by interrupts triggered by the RDRF and TDRE bits in SISTR.

Set this bit to 1 if SIRCDR and SITCDR are used. This will cause interrupts triggered by the RDRF and TDRE bits in SISTR to be processed by the DMAC and interrupts triggered by the RCD and TCD bits in SISTR to be processed by the CPU.

Clear this bit to 0 if SIRCDR and SITCDR are not used, or if all interrupts triggered by the RDRF, TDRE, RCD and TCD bits in SISTR are to be processed by the CPU. The initial value of this bit is 0.

Bit 10: DMACE	Description
0	DMAC is activated by RDRF and TDRE interrupts (Initial value)
1	DMAC is not activated by RDRF and TDRE interrupts

Bit 9—Transmit-Control-Data-Register-Empty Interrupt Enable (TCIE): Enables the transmit-control-data-register-empty interrupt. The initial value of this bit is 0.

Bit 9: TCIE	Description
0	Transmit-control-data-register-empty interrupt disabled (Initial value)
1	Transmit-control-data-register-empty interrupt enabled

Bit 8—Receive-Control-Data-Register-Full Interrupt Enable (RCIE): Enables the receive-control-data-register-full interrupt. The initial value of this bit is 0.

Bit 8: RCIE	Description
0	Receive-control-data-register-full interrupt disabled (Initial value)
1	Receive-control-data-register-full interrupt enabled

Bit 7—Reserved: This bit is always read as 0. The write value should always be 0.

Bit 6—Transfer Mode Control (TM): Specifies whether the transmission synchronization signal is to be input from an external source or generated internally by the chip. When this flag is cleared, the transmission synchronization signal is STS pin input. When this flag is set, the transmission synchronization signal is generated by the chip, and is output to an external device from the STS pin. This bit does not affect reception.

Bit 6: TM	Description
0	External signal input from STS pin is used as transmission start indication (Initial value)
1	Internal signal output from STS pin is used as transmission start indication

Note: If the transmit mode bit (TRMD) in SIFCR is set to 1, this bit must be cleared to 0. If TM is set to 1 and SE is set to 1 (interval mode), output of the sync signal stops at the point at which bits T4 to T0 in SIFDR are cleared to 0 (data count of transmit data register is zero). If TE remains set to 1 and data is written to SITDR, output of the sync signal resumes when the value of T4 to T0 in SIFDR becomes H'01 or above.

Bit 5—Synchronization Signal Enable (SE): Specifies whether the synchronization signals are to be used for all serial data transfers, or only for the first transfer.

When this bit is cleared to 0, the synchronization signals (SRS and STS) are necessary only for the first data transfer, and are not required for subsequent transfers. When this bit is set to 1, the synchronization signals are necessary for all data transfers.

Bit 5: SE	Description
0	Continuous mode: SRS and STS are used only for the first data transfer (Initial value)
1	Interval mode: SRS and STS are used for all data transfers

Note: If TRMD in SIFCR is set to 1, this bit must be cleared to 1. When TM is cleared to 0 and SE is cleared to 0, after data is input SRS/STS once nothing further should be input to SRS/STS between the start and completion of transmission/receiving (transmit FIFO empty/receive FIFO full).

Bit 4—Transmit/Receive Data Length Select (DL): Specifies the serial I/O module’s transfer data length. The initial value of this bit is 0, indicating an 8-bit data length. When an 8-bit data length is specified, the lower 8 bits in the receive shift register, receive data register, transmit shift register, transmit data register, receive control data register, and transmit control data register are used.

Bit 4: DL	Description
0	8-bit transfer data length (Initial value)
1	16-bit transfer data length

Bit 3—Transmit Interrupt Enable (TIE): Enables the transmit-data-empty interrupt. The initial value of this bit is 0.

Bit 3: TIE	Description
0	Transmit interrupt disabled (Initial value)
1	Transmit interrupt enabled

Bit 2—Receive Interrupt Enable (RIE): Enables the receive-data-full interrupt. The initial value of this bit is 0.

Bit 2: RIE	Description
0	Receive interrupt disabled (Initial value)
1	Receive interrupt enabled

Bit 1—Enables data transmission. When this flag is cleared, the STXD pin goes to the high-impedance state. When TM is set to 1, the STS pin also goes to the high-impedance state.

Bit 1: TE	Description
0	Transmission disabled: STxD pin goes to high-impedance state (Initial value) When TM is set to 1, STS pin goes to high-impedance state
1	Transmission enabled

Bit 0—Receive Enable (RE): Enables data reception.

Bit 0: RE	Description
0	Reception disabled (Initial value)
1	Reception enabled

15.2.6 Serial Status Register (SISTR)

Bit:	15	14	...	9	8	...	4	3	2	1	0
	—	—	...	TCD	RCD	...	—	TERR	RERR	TDRE	RDRF
Initial value:	0	0	...	1	0	...	0	0	0	1	0
R/W:	R	R	...	R/(W)*	R/(W)*	...	R	R/(W)*	R/(W)*	R/(W)*	R/(W)*

Note: * Only 0 should be written, to clear the flag.

SISTR is a 16-bit register that indicates the status of the serial I/O module. SISTR is initialized to H'0002 by a reset. When the TFRST bit in SIFCR is set to 1, the TERR and TDRE bits are also initialized. When the RFRST bit in SIFCR is set to 1, the RERR and RDRF bits are also initialized.

Bits 15 to 4—Reserved: These bits are always read as 0. The write value should always be 0.

Bit 9—Transmit Control Data Register Empty (TCD): This flag indicates when SITCDR is empty and can be written to.

Bit 9: TCD	Description
0	SITCDR transmit data is valid TCD is cleared to 0 in the following cases: <ul style="list-style-type: none"> • When 0 is written to TCD after reading TCD = 1
1	SITCDR transmit data is invalid (Initial value) TCD is set to 1 in the following cases: <ul style="list-style-type: none"> • After data is transferred from SITCDR to SITSR • When the processor is reset

Bit 8—Receive Control Data Register Full (RCD): This flag indicates when SIRCDR is in wait status.

Bit 8: RCD	Description
0	SIRCDR receive data is invalid (Initial value) RCD is cleared to 0 in the following cases: <ul style="list-style-type: none"> • When 0 is written to RCD after reading RCD = 1 • When the processor is reset
1	SIRCDR transmit data is valid RCD is set to 1 in the following cases: <ul style="list-style-type: none"> • After control data has been received normally and data has been transferred from SIRSR to SIRCDR

Bit 7 to 4—Reserved: This bit is always read as 0. The write value should always be 0.

Bit 3—Transmit Underrun Error (TERR): Flag that indicates the occurrence of a transmit underrun.

Bit 3: TERR	Description
0	Transmission is in progress, or has ended normally (Initial value) [Clearing conditions] <ul style="list-style-type: none">• When 0 is written to the TERR bit after reading TERR = 1• When the TFRST bit in SIFCR is set to 1• When the processor enters the reset state
1	A transmit underrun error has occurred <ul style="list-style-type: none">• When the amount of primary transmit data in SITDR is 0 and data is transferred from SITDR to SITSR using a transmit operation

Bit 2—Receive Overrun Error (RERR): Flag that indicates the occurrence of a receive overrun.

Bit 2: RERR	Description
0	Reception is in progress, or has ended normally (Initial value) [Clearing conditions] <ul style="list-style-type: none">• When 0 is written to the RERR bit after reading RERR = 1• When the RFRST bit in SIFCR is set to 1• When the processor enters the reset state
1	A receive overrun error has occurred RERR is set to 1 in the following cases: <ul style="list-style-type: none">• When the amount of primary receive data in SIRDR is 16 and the next primary data receive operation completes

Bit 1—Transmit Data Register Empty (TDRE): Flag that indicates that primary data has been transferred from SITDR to SITSR and the amount of data inside SITDR is less than or equal to the setting of TFWM3 to TFWM0 in SIFCR.

Bit 1: TDRE	Description
0	<p>Indicates that primary send data exceeding the transmit FIFO watermark setting has been written to SITDR</p> <p>TDRE is cleared to 0 in the following cases:</p> <ul style="list-style-type: none"> • When primary send data exceeding the setting of the transmit FIFO watermark bits has been written to SITDR and 0 is written to TDRE after reading TDRE = 1 • When the DMAC has written primary send data exceeding the setting of the transmit FIFO watermark bits to SITDR
1	<p>Indicates that the amount of primary send data in SITDR is less than or equal to the transmit FIFO watermark setting (Initial value)</p> <p>TDRE is set to 1 in the following cases:</p> <ul style="list-style-type: none"> • When the amount of primary send data in SITDR is less than or equal to the transmit FIFO watermark setting • When the TFRST bit in SIFCR is set to 1 • When the processor is reset

Bit 0—Receive Data Register Full (RDRF): Flag that indicates that SIRDR receive data is waiting.

Bit 0: RDRF	Description
0	<p>Indicates that the amount of primary receive data in SIRDR is less than the receive FIFO watermark setting (Initial value)</p> <p>RDRF is cleared to 0 in the following cases:</p> <ul style="list-style-type: none"> • When the received primary data in SIRDR has been read to the point that the amount of remaining data is less than the receive FIFO watermark setting and 0 is written to RDRF after reading RDRF = 1 • When the DMAC has read the received primary data in SIRDR to the point that the amount of remaining data is less than the receive FIFO watermark setting • When the RFRST bit in SIFCR is set to 1 • When the processor is reset
1	<p>Indicates that the amount of primary receive data in SIRDR is greater than or equal to the receive FIFO watermark setting</p> <p>RDRF is set to 1 in the following cases:</p> <ul style="list-style-type: none"> • When the received primary data stored in SIRDR is greater than or equal to the receive FIFO watermark setting

15.2.7 Receive Control Data Register (SIRCDR)

Bit:	15	14	13	12	11	10	9	8	7	6	5	4	3	2	1	0
	<input type="checkbox"/>	<input type="checkbox"/>	<input type="checkbox"/>	<input type="checkbox"/>	<input type="checkbox"/>	<input type="checkbox"/>	<input type="checkbox"/>	<input type="checkbox"/>	<input type="checkbox"/>	<input type="checkbox"/>	<input type="checkbox"/>	<input type="checkbox"/>	<input type="checkbox"/>	<input type="checkbox"/>	<input type="checkbox"/>	<input type="checkbox"/>
Initial value:	0	0	0	0	0	0	0	0	0	0	0	0	0	0	0	0
R/W:	R	R	R	R	R	R	R	R	R	R	R	R	R	R	R	R

SIRCDR is a register that stores receive control data. Received data is stored in SIRCDR as receive control data, synchronized with the timing used for transmission of transmit control data from SITCDR.

The RCD bit in SISTR is set at the same time as control data is being transferred from SIRS to SIRCDR. When the RCIE pin in SICTR is set, a receive-control-data-full interrupt request (RDFI) is sent to the INTC. No interrupt request signal is issued if the flag is cleared.

SIRCDR is initialized to H'0000 by a reset.

If the DL bit is cleared to 0 (data length 8 bits), the received control data is fetched to the lower 8 bits, and the upper 8 bits are cleared to 0.

15.2.8 Transmit Control Data Register (SITCDR)

Bit:	15	14	13	12	11	10	9	8	7	6	5	4	3	2	1	0
	<input type="checkbox"/>	<input type="checkbox"/>	<input type="checkbox"/>	<input type="checkbox"/>	<input type="checkbox"/>	<input type="checkbox"/>	<input type="checkbox"/>	<input type="checkbox"/>	<input type="checkbox"/>	<input type="checkbox"/>	<input type="checkbox"/>	<input type="checkbox"/>	<input type="checkbox"/>	<input type="checkbox"/>	<input type="checkbox"/>	<input type="checkbox"/>
Initial value:	0	0	0	0	0	0	0	0	0	0	0	0	0	0	0	0
R/W:	R/W	R/W	R/W	R/W	R/W	R/W	R/W	R/W	R/W	R/W	R/W	R/W	R/W	R/W	R/W	R/W

SITCDR is a register that stores transmit control data.

Data should be written to SITCDR when the TCD bit is set to 1 in SISTR (SITCDR transmit data invalid). If data is written to SITCDR when TCD in SISTR is cleared to 0, the previous data will be overwritten. After writing transmit control data to SITCDR, 1 should be read from TCD in SISTR and then 0 written to it. This makes the transmit data in SITCDR valid and causes the transmit control data to be transmitted.

After TRMD in SIFCR is set to 1 transmission starts, a read interrupt is issued to SITCDR. STS goes high and primary data bit 0 is transmitted as 1. When STS next goes high the control data stored in SITCDR is transferred to SITSR. If the TCD bit is 0 at this point, and TCD bit is set to 1. After this the control data previously transferred from SITCDR to SITSR is transmitted.

If the TRMD bit is cleared to 0, no control data is transmitted even if data is written to SITCDR.

If the TCD bit in SISTR is set to 1 and the TCIE bit in SICTR is set to 1, a transmit-control-data-empty interrupt (TDEI0) request is sent to the INTC. If the flag is cleared, this interrupt request is not generated.

The TCD bit in SISTR is set only by hardware.

SITCDR is initialized to H'0000 by a reset.

15.2.9 FIFO Control Register (SIFCR)

Bit:	15	14	13	12	11	10	9	8	7	6	5	4	3	2	1	0
	—	—	—	—	TRMD	LM	RFR ST	TFR ST	RFBW 3	RFBW 2	RFBW 1	RFBW 0	TFWM 3	TFWM 2	TFWM 1	TFWM 0
Initial value:	0	0	0	0	0	0	0	0	0	0	0	0	0	0	0	0
R/W:	R	R	R	R	R/W	R/W	R/W	R/W	R/W	R/W	R/W	R/W	R/W	R/W	R/W	R/W

SIFCR is a register used to perform software resets and to make threshold settings for SIRDR and SITDR.

It also contains a bit used to select LSB first or MSB first when transmitting and receiving to match the connected codec, as well as a bit for controlling the LSB for transmitted primary data and control data.

SIFCR is initialized to H'0000 by a reset.

Note that the TE and RE bits in SICTR must be cleared to 0 before changing the values of bits 11 to 10 and 7 to 0 (TRMD, LM, RFBW3 to RFBW0, TFWM3 to TFWM0).

Bit 15 to 12—Reserved: These bits are always read as 0. The write value should always be 0.

Bit 11—Transfer Mode (TRMD): Controls the LSB (bit 0) for transmitted primary data and control data.

Bit 11: TRMD	Description
0	Value stored in SITDR is always transmitted as LSB of primary data (Initial value)
1	LSB of primary data is always transmitted as 0 However, the LSB is 1 when the primary data immediately precedes control data

Note: If the TRMD bit is set to 1, in SICTR the TM bit (STS pin input) should be cleared to 0, the SE bit (interval mode) set to 1, and the LM bit (transmit/receive MSB format) cleared to 0. The sync signal output from the connected codec should be input to pins STS and SRS. The serial clock output from the connected codec should be input to pins STCK and SRCK.

Bit 10—LSB/MSB First Select (LM): Used to select LSB first or MSB first for transmitting and receiving.

Bit 10: LM	Description
0	MSB first for transmitting and receiving (Initial value)
1	LSB first for transmitting and receiving

Note: This bit must be cleared to 0 if the TRMD bit is set to 1.

Bit 9—Receive FIFO Data Register Reset (RFRST): Invalidates the primary receive data in SIRD and resets it to empty status. Also initializes the RERR and RDRF bits in SISTR.

Note that SICTR is not initialized, so receiving continues if the RE bit is set to 1.

Bit 9: RFRST	Description
0	Reset disabled (Initial value)
1	Reset enabled

Note: Reset status persists while this bit is set to 1. Clear this bit to 0 to cancel reset status.

Bit 8—Transmit FIFO Data Register Reset (TFRST): Invalidates the transmit data in SITDR and resets it to empty status. Also initializes the TERR and TDRE bits in SISTR.

Note that SICTR is not initialized, so transmitting continues if the TE bit is set to 1.

Bit 8: TFRST	Description
0	Reset disabled (Initial value)
1	Reset enabled

Note: Reset status persists while this bit is set to 1. Clear this bit to 0 to cancel reset status.

Bit 7 to 4—Receive FIFO Watermark (RFBM3 to RFBM0): These bits are used to make threshold settings, which are used to set the RDRF bit in SISTR.

When the amount of primary receive data in SIRDR is equal to or greater than the watermark setting, as shown in the table below, the RDRF bit is set to 1.

Bit 7: RFBM3	Bit 6: RFBM2	Bit 5: RFBM1	Bit 4: RFBM0	Watermark setting
0	0	0	0	1 (Initial value)
			1	2
		1	0	3
			1	4
	1	0	0	5
			1	6
		1	0	7
			1	8
1	0	0	0	9
			1	10
		1	0	11
			1	12
	1	0	0	13
			1	14
		1	0	15
			1	16

Bit 3 to 0— Transmit FIFO Watermark (TFWM3 to TFWM0): These bits are used to make threshold settings, which are used to set the TDRE bit in SISTR.

When the amount of primary send data in SITDR is less than or equal to the watermark setting, as shown in the table below, the TDRE bit is set to 1.

Bit 3: TFWM3	Bit 2: TFWM2	Bit 1: TFWM1	Bit 0: TFWM0	Watermark setting	
0	0	0	0	0 (Initial value)	
			1	1	
		1	0	2	
	1	0	0	1	3
				0	4
		1	0	1	5
				0	6
1	0	0	1	7	
			0	8	
		1	9		
	1	0	1	0	10
				1	11
		1	0	0	12
				1	13
1	1	0	14		
		1	15		

15.2.10 FIFO Data Count Register (SIFDR)

Bit:	15	14	13	12	11	10	9	8	7	6	5	4	3	2	1	0
	—	—	—	R4	R3	R2	R1	R0	—	—	—	T4	T3	T2	T1	T0
Initial value:	0	0	0	0	0	0	0	0	0	0	0	0	0	0	0	0
R/W:	R	R	R	R	R	R	R	R	R	R	R	R	R	R	R	R

SIFDR is a register that indicates the amount of primary data stored in SIRDR and SITDR.

The upper 8 bits indicate the amount of primary receive data stored in SIRDR, and the lower 8 bits indicate the amount of primary transmit data stored in SITDR.

SIFDR is initialized to H'0000 by a reset. Also, it can be initialized to H'0000 by setting bits RFRST and TFRST of SIFCR to 1.

Bit 15 to 13—Reserved: These bits are always read as 0.

Bit 12 to 8—Receive Data Register Data Count Bits 4 to 0 (R4 to R0): These bits indicate the amount of primary receive data stored in SIRDR.

When the value of bits R4 to R0 is H'00 there is no primary receive data stored in SIRDR, and when the value is H'10 SIRDR is full. In addition to the initialized status mentioned above, bits R4 to R0 can be cleared to H'00 by reading all the primary receive data from SIRDR.

Bit 7 to 5—Reserved: These bits are always read as 0.

Bit 4 to 0—Transmit Data Register Data Count Bits 4 to 0 (T4 to T0): These bits indicate the amount of untransmitted primary data stored in SITDR.

When the value of bits T4 to T0 is H'00 there is no primary transmit data waiting to be transmitted, and when the value is H'10 SITDR is full. In addition to the initialized status mentioned above, bits T4 to T0 can be cleared to H'00 by transmitting all the primary transmit data.

15.3 Operation

15.3.1 Input when TRMD = 0 in SIFCR

Figure 15.2 shows interval transfer mode (SE set to 1 in SICTR) with MSB first (LM cleared to 0 in SIFCR).

Figure 15.3 shows continuous transfer mode (SE cleared to 0 in SICTR) with MSB first (LM cleared to 0 in SIFCR).

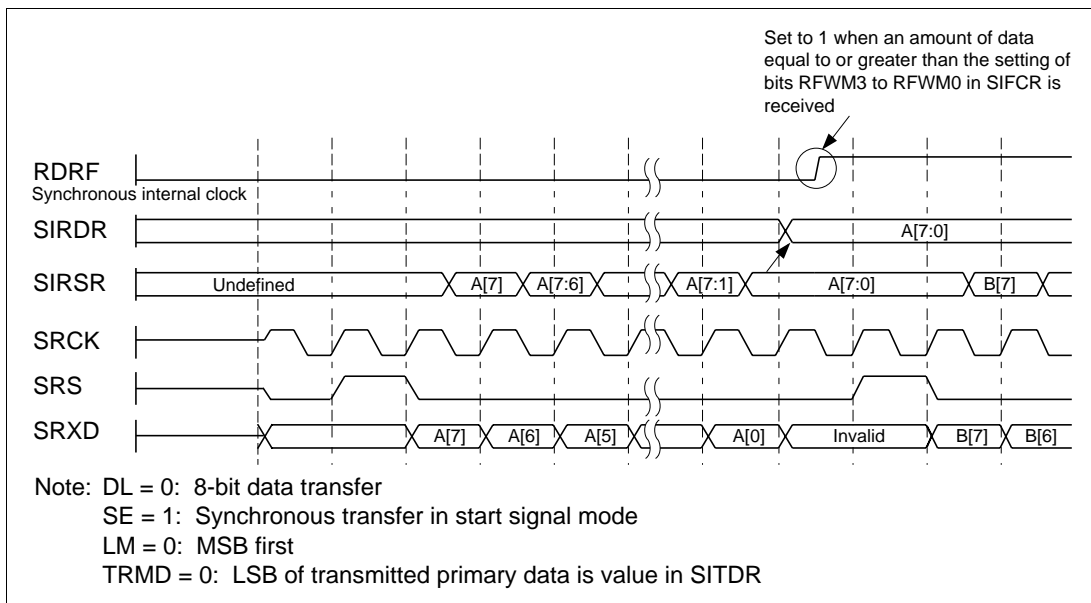

Figure 15.2 Reception: Interval Transfer Mode/MSB First

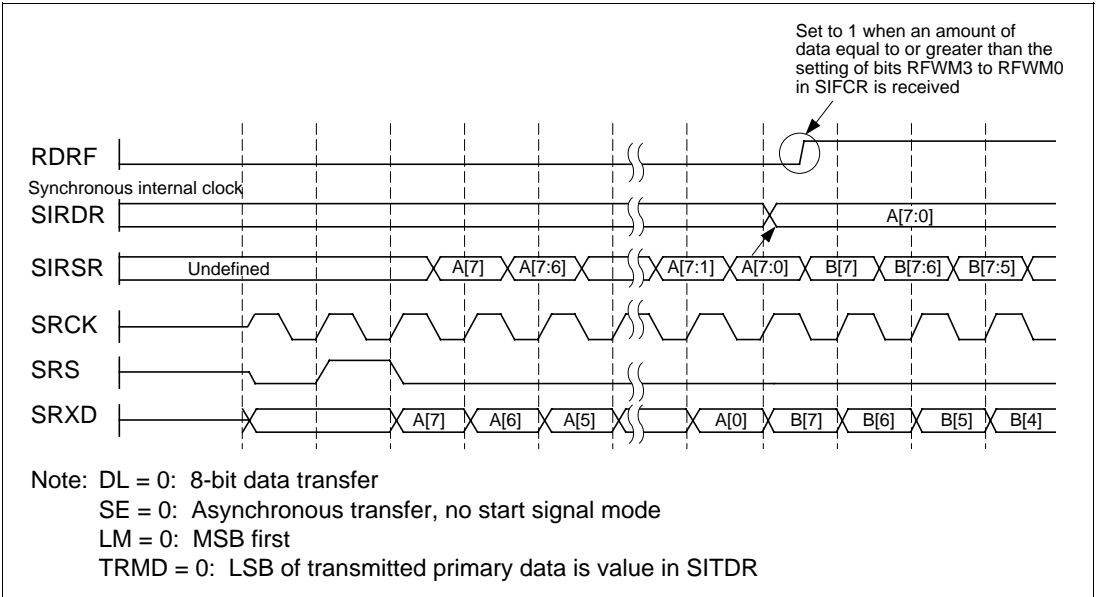

Figure 15.3 Reception: Continuous Transfer Mode/MSB First

Figure 15.4 shows interval transfer mode (SE set to 1 in SICTR) with LSB first (LM set to 1 in SIFCR).

Figure 15.5 shows continuous transfer mode (SE cleared to 0 in SICTR) with LSB first (LM set to 1 in SIFCR).

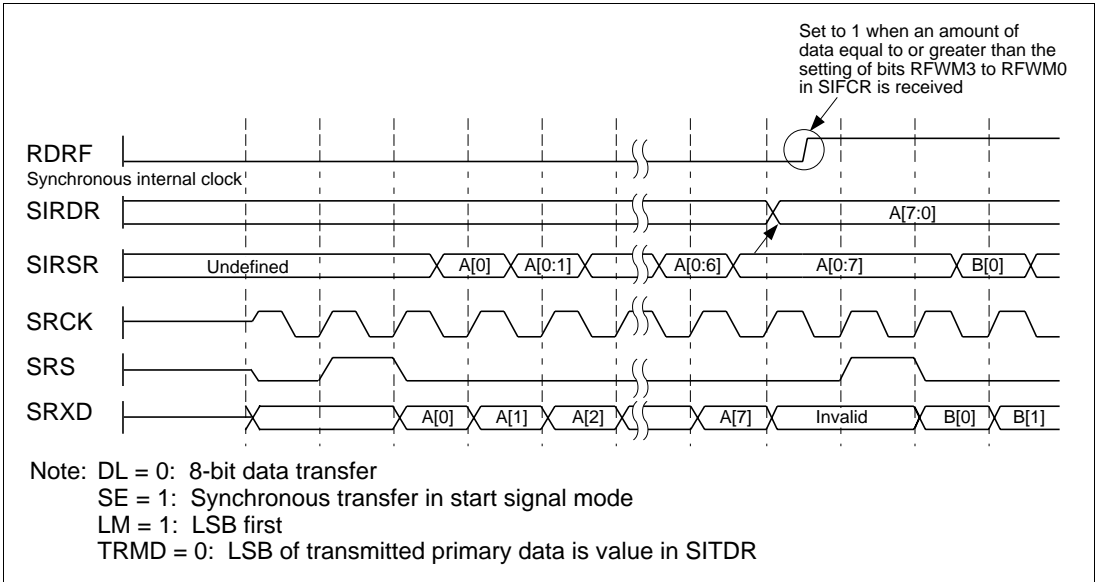

Figure 15.4 Reception: Interval Transfer Mode/LSB First

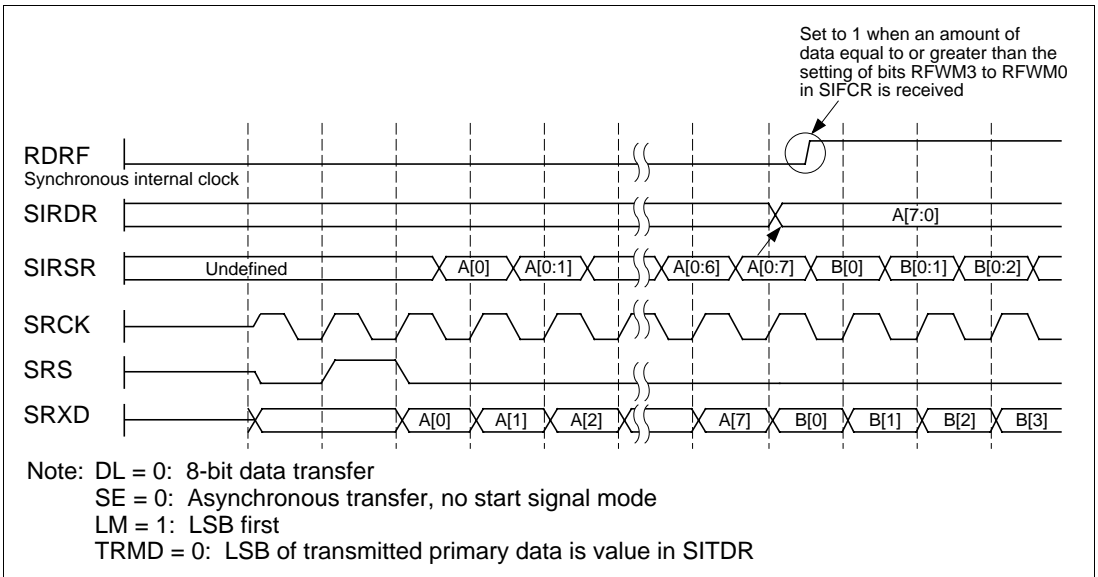

Figure 15.5 Reception: Continuous Transfer Mode/LSB First

15.3.2 Output when TRMD = 0 in SIFCR

Figure 15.6 shows interval transfer mode when TM is cleared to 0 in SICTR and with MSB first.

Figure 15.7 shows continuous transfer mode when TM is cleared to 0 in SICTR and with MSB first.

Figure 15.8 shows interval transfer mode when TM is set to 1 in SICTR and with MSB first.

Figure 15.9 shows continuous transfer mode when TM is set to 1 in SICTR and with MSB first.

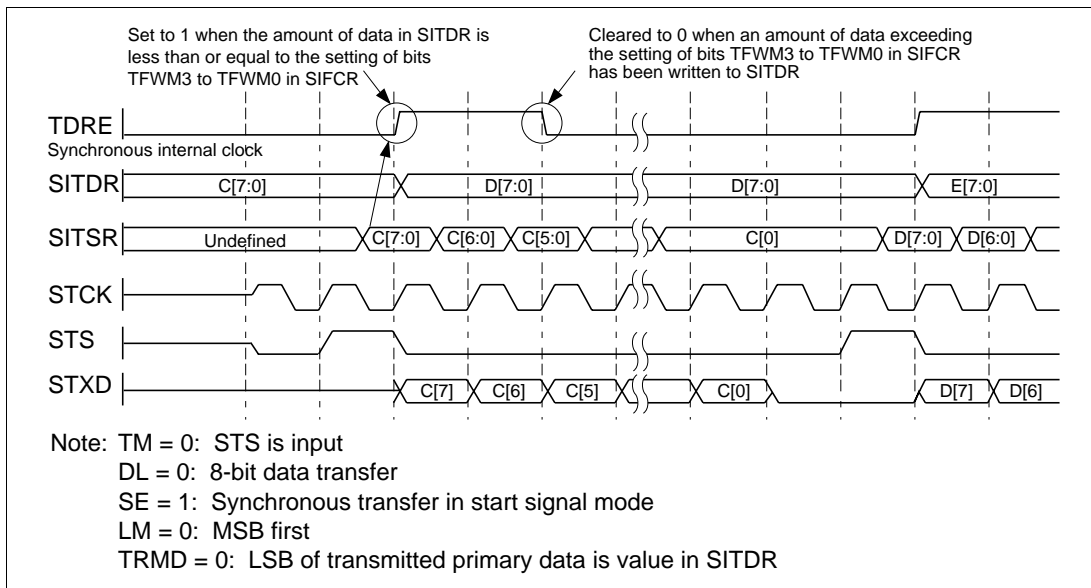

Figure 15.6 Transmission: Interval Transfer Mode (TM = 0 Mode)/MSB First

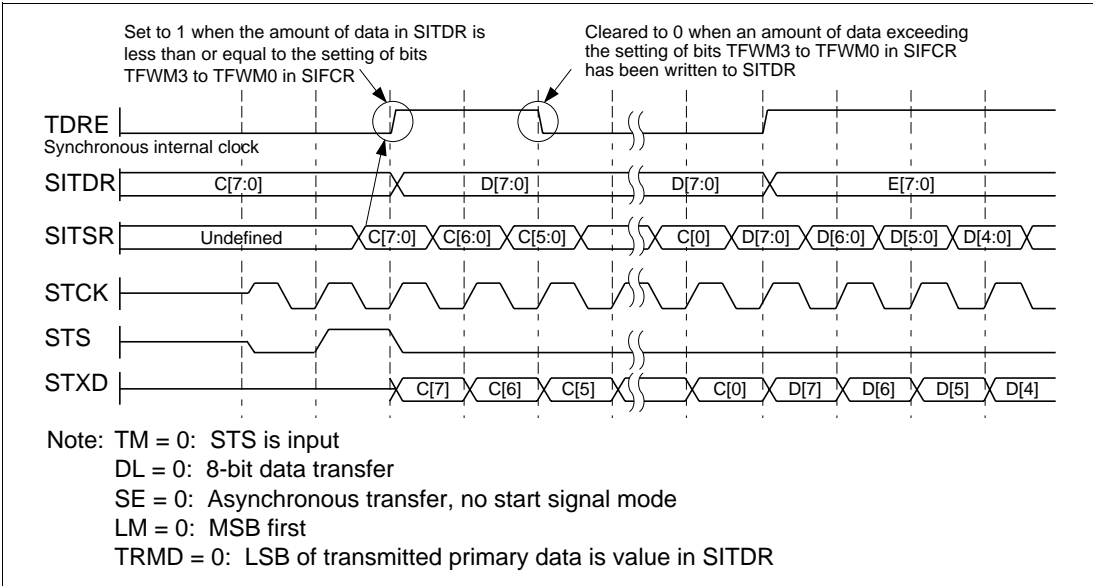

Figure 15.7 Transmission: Continuous Transfer Mode (TM = 0 Mode)/MSB First

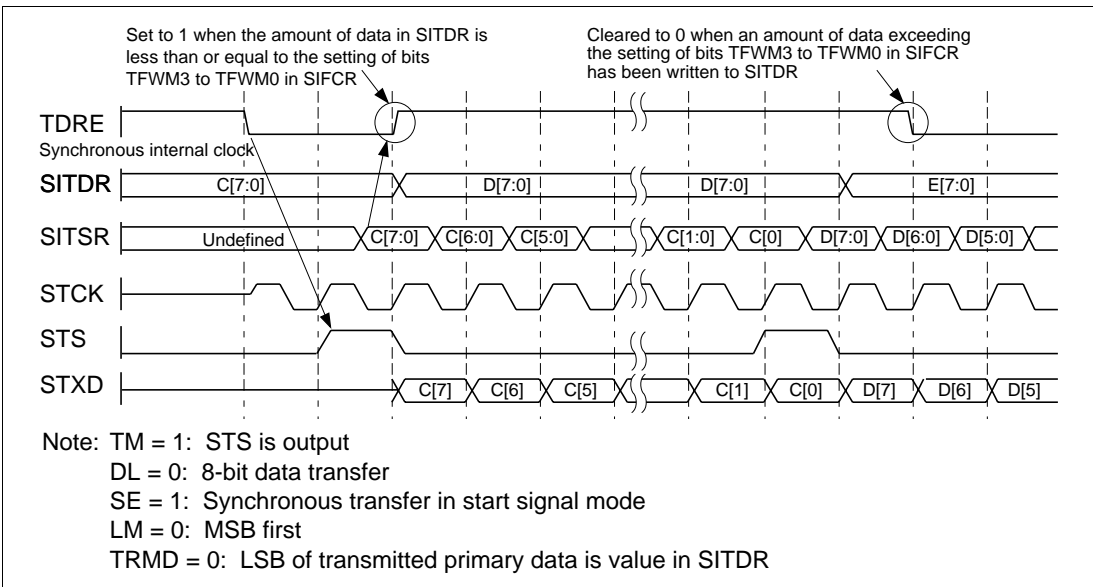

Figure 15.8 Transmission: Interval Transfer Mode (TM = 1 Mode)/MSB First

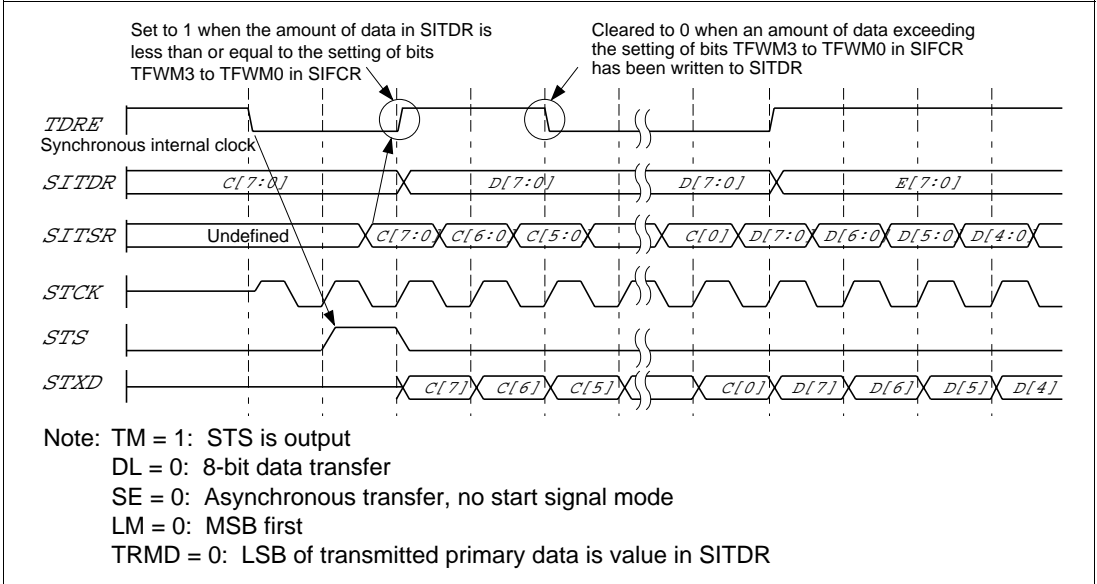

Figure 15.9 Transmission: Continuous Transfer Mode (TM = 1 Mode)/MSB First

Figure 15.10 shows interval transfer mode when TM is cleared to 0 in SICTR and with LSB first.

Figure 15.11 shows continuous transfer mode when TM is cleared to 0 in SICTR and with LSB first.

Figure 15.12 shows interval transfer mode when TM is set to 1 in SICTR and with LSB first.

Figure 15.13 shows continuous transfer mode when TM is set to 1 in SICTR and with LSB first.

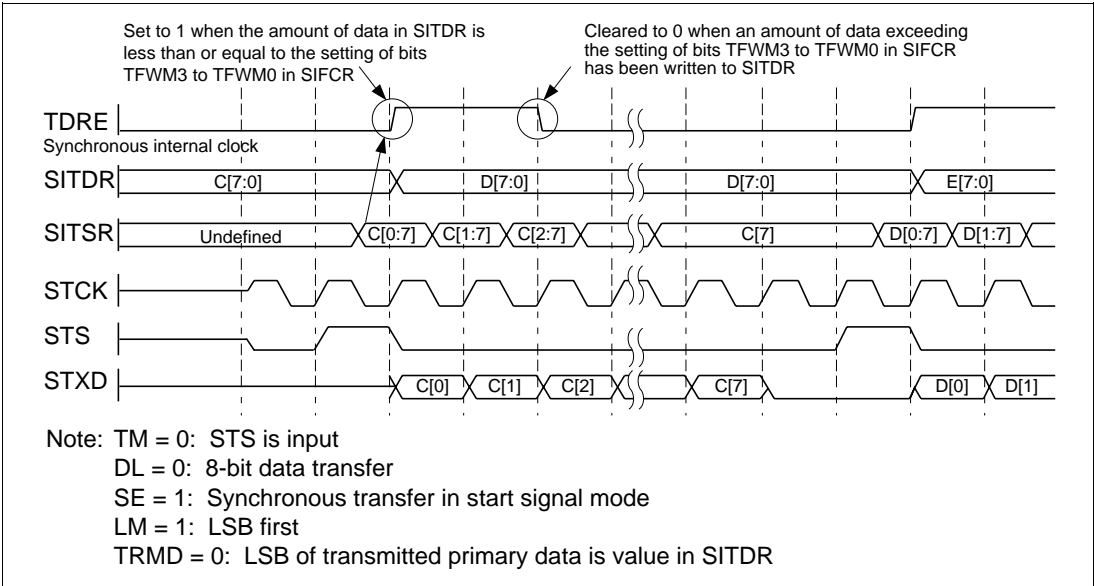

Figure 15.10 Transmission: Interval Transfer Mode (TM = 0 Mode)/LSB First

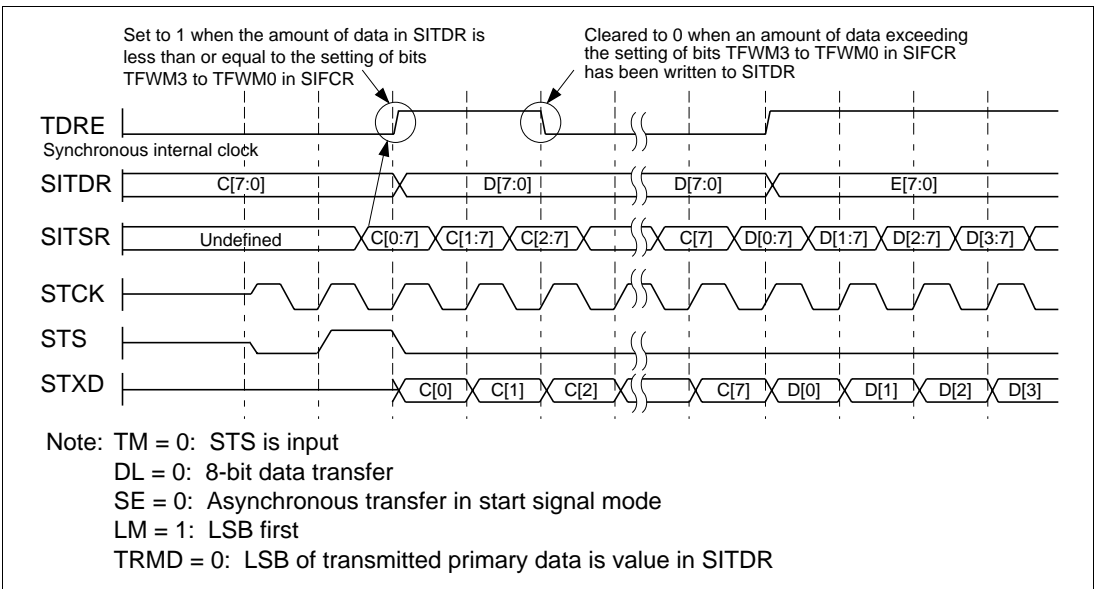

Figure 15.11 Transmission: Continuous Transfer Mode (TM = 0 Mode)/LSB First

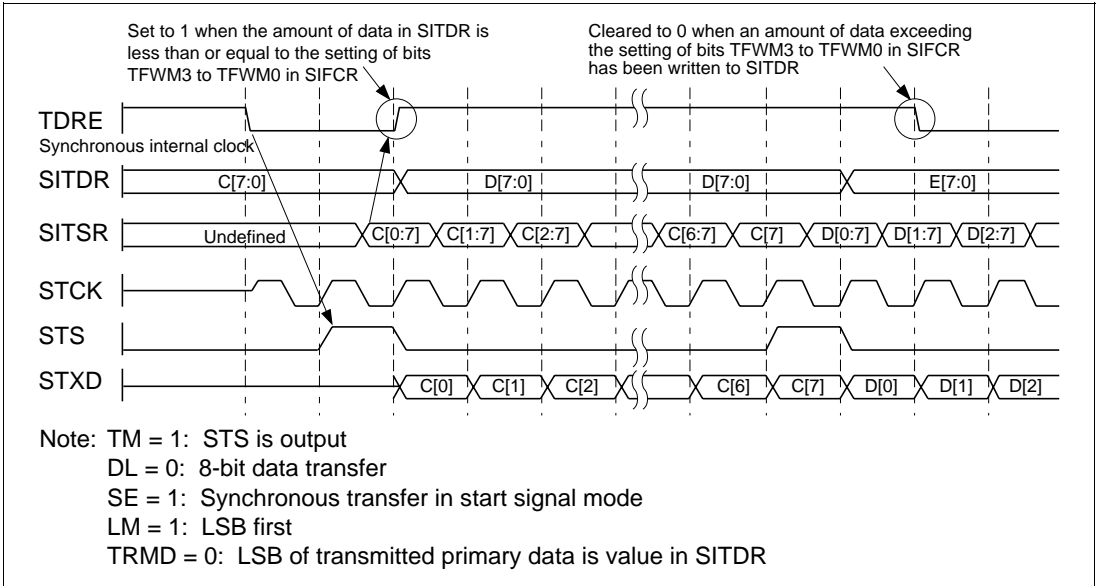

Figure 15.12 Transmission: Interval Transfer Mode (TM = 1 Mode)/LSB First

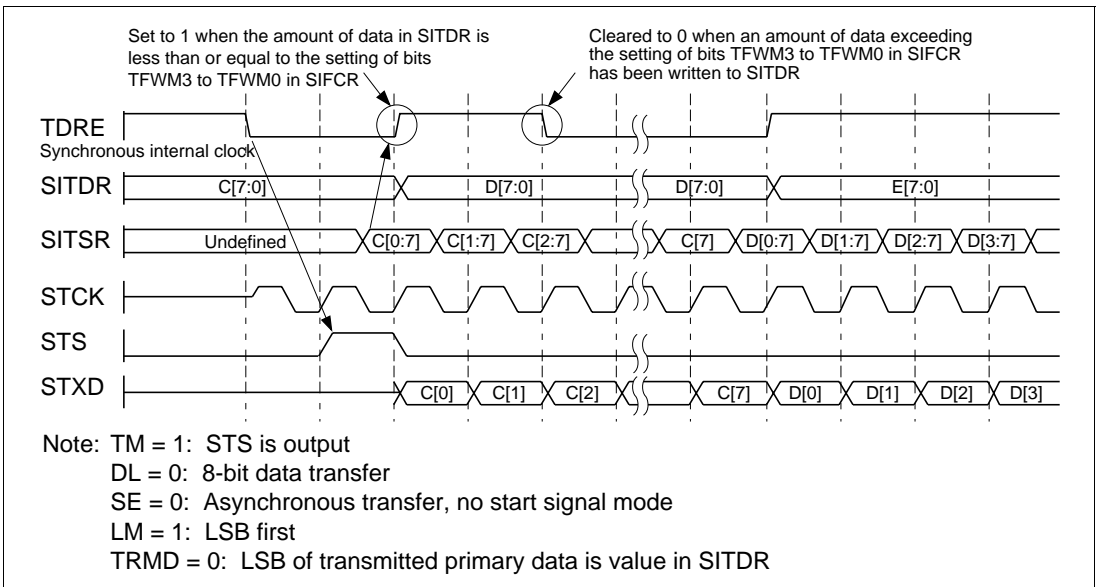
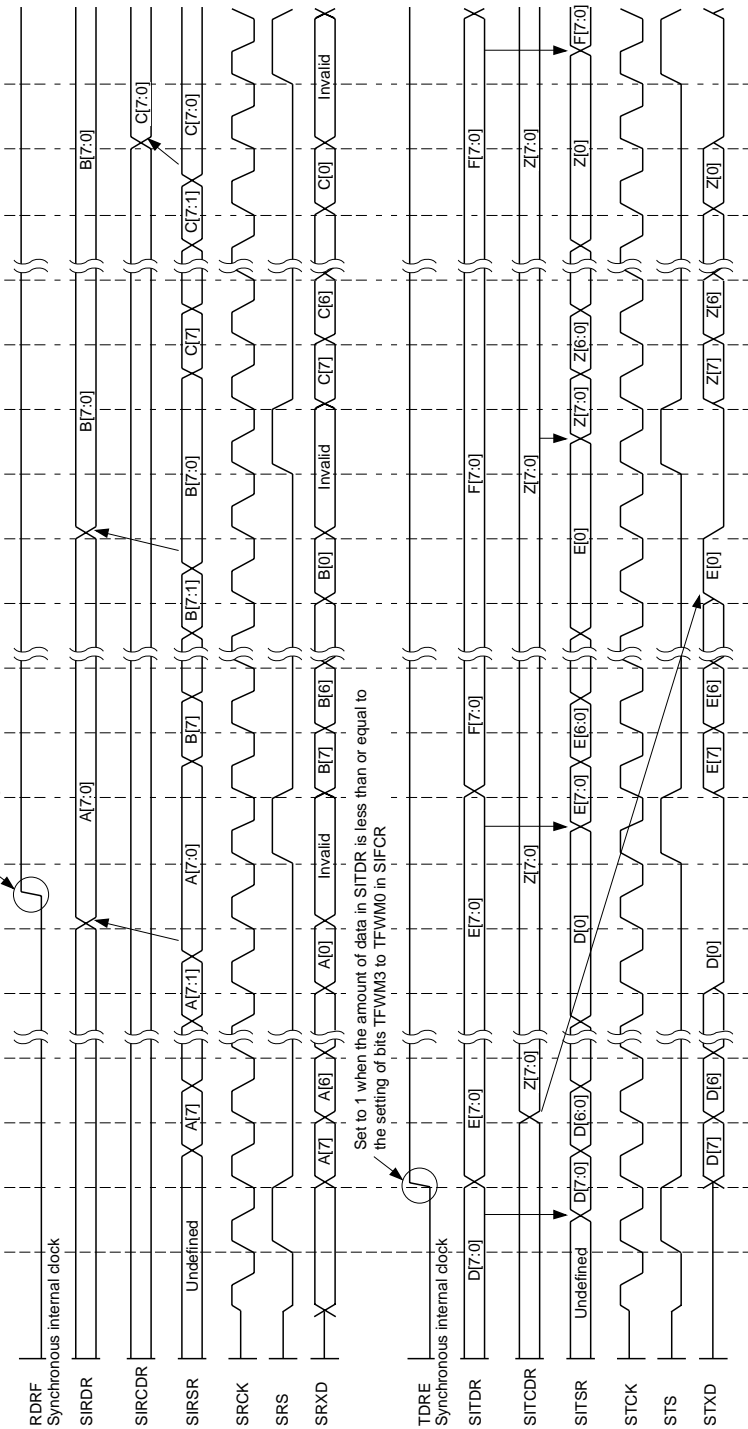

Figure 15.13 Transmission: Continuous Transfer Mode (TM = 1 Mode)/LSB First

15.3.3 Output when TRMD = 1 in SIFCR

Figure 15.14 shows output timing when TM is set to 1 in SIFTR.

Set to 1 when an amount of data equal to or greater than the setting of bits RFWM3 to RFWM0 in SIFCR is received



Note: TM = 0: STS is input
 DL = 0: 8-bit data transfer
 SE = 1: Synchronous transfer in start signal mode
 LM = 0: MSB first
 TRMD = 1: LSB of transmitted primary data is 0

Figure 15.14 Transmission: TRMD = 1 Mode

15.4 SIOF Interrupt Sources and DMAC

Each SIOF channel has four interrupt sources: the receive-overflow-error interrupt (RERI) request, transmit-underrun-error interrupt (TERI) request, receive-data-full interrupt (RDFI) request, and transmit-data-empty interrupt (TDEI) request. Table 15.3 shows the interrupt sources and their relative priorities. The RDFI and TDEI interrupts are enabled by the RIE and TIE bits, respectively, in SICTR. The RERI0 and TERI0 interrupts cannot be disabled.

An RDFI0 interrupt request is generated when the RDRF bit is set to 1 or the RCD bit is set to 1 in SISTR.

The DMACE bit should be cleared to 0 in SICTR to have interrupts triggered by both the RDRF bit and the RCD bit processed by the CPU. In this case the CPU should process interrupts after reading SISTR and determining which bit triggered them.

Set the DMACE bit to 1 in SICTR to have interrupts triggered by the RDRF bit processed by the DMAC and interrupts triggered by the RCD bit processed by the CPU. In addition, the priority of interrupts from SIOF should be set to a high level in order to activate the interrupt controller (INTC). This will cause interrupts triggered by the RDRF bit to be sent to the DMAC and interrupts triggered by the RCD bit to be sent to the INTC. The data in SIRDR is read and if the amount of primary data is less than the setting of bits RFWM3 to RFWM0 in SIFCR, RDRF is automatically cleared to 0. Interrupts triggered by the RCD bit cannot be processed by the DMAC.

An TDEI0 interrupt request is generated when the TDRE bit is set to 1 or the TCD bit is set to 1 in SISTR.

The DMACE bit should be cleared to 0 in SICTR to have interrupts triggered by both the TDRE bit and the TCD bit processed by the CPU. In this case the CPU should process interrupts after reading SISTR and determining which bit triggered them.

Set the DMACE bit to 1 in SICTR to have interrupts triggered by the TDRE bit processed by the DMAC and interrupts triggered by the TCD bit processed by the CPU. In addition, the priority of interrupts from SIOF should be set to a high level in order to activate the INTC. This will cause interrupts triggered by the TDRE bit to be sent to the DMAC and interrupts triggered by the TCD bit to be sent to the INTC. The DMAC writes data to SIRDR and if the amount of primary data is equal to or greater than the setting of bits TFWM3 to TFWM0 in SIFCR, TDRE is automatically cleared to 0. Interrupts triggered by the TCD bit cannot be processed by the DMAC.

When the RERR bit is set to 1 in SISTR, an RERI0 interrupt request is generated.

When the TERR bit is set to 1 in SISTR, a TERI0 interrupt request is generated.

Channel interrupt priority levels are set by means of the IRPE register, as described in section 5, Interrupt Controller (INTC).

Table 15.3 SIOF Interrupt Sources

Interrupt Source	Description	DMAC Activation	Priority
RERI	Receive overrun error (RERR)	Not possible	High
TERI	Transmit underrun error (TERR)	Not possible	↑
RDFI	Receive data register full (RDRF)	Possible*	↓
TDEI	Transmit data register empty (TDRE)	Possible*	Low

Note: * The interrupt sources that can activate the DMAC are receive data full (RDRF) and transmit data empty (TDRE).

It is not possible for receive control data full (RCD) or transmit control data empty (TCD) to activate the DMAC.

The DMAC should be used to process RDRF and TDRE interrupts when using SIRCDR and SITCDR, and the DMACE bit must be set to 1 in SICTR when using the CPU to process RCD and TCD interrupts.

The DMACE bit should be cleared to 0 in SICTR if neither SIRCDR nor SITCDR is used and both RDRF and TDRE interrupts as well as RCD and TCD interrupts are to be processed by the CPU.

Section 16 Serial I/O (SIO)

16.1 Overview

A two-channel simple synchronous serial I/O is provided on-chip. The serial I/O functions mainly as an interface between the chip and a codec or modem analog front-end.

16.1.1 Features

The serial I/O has the following features:

- Full-duplex operation
Independent transmit/receive registers and independent transmit/receive clocks
- Double-buffered transmit/receive ports
Continuous data transmission/reception possible
- Interval transfer mode and continuous transfer mode
- Memory-mapped receive register, transmit register, control register, and status register
With the exception of SIRSRSR and SITSR, these registers are memory-mapped and can be accessed by a MOV instruction.
- Choice of 8- or 16-bit data length
- Data transfer communication by means of polling or interrupts
Data transfer can be monitored by polling the receive data register full flag (RDRF) and transmit data register empty flag (TDRE) in the serial status register. Interrupt requests can be generated during data transfer by setting the receive interrupt request flag and transmit interrupt request flag.
- MSB-first transfer between SIO and data I/O

Figure 16.1 shows a block diagram of the serial I/O.

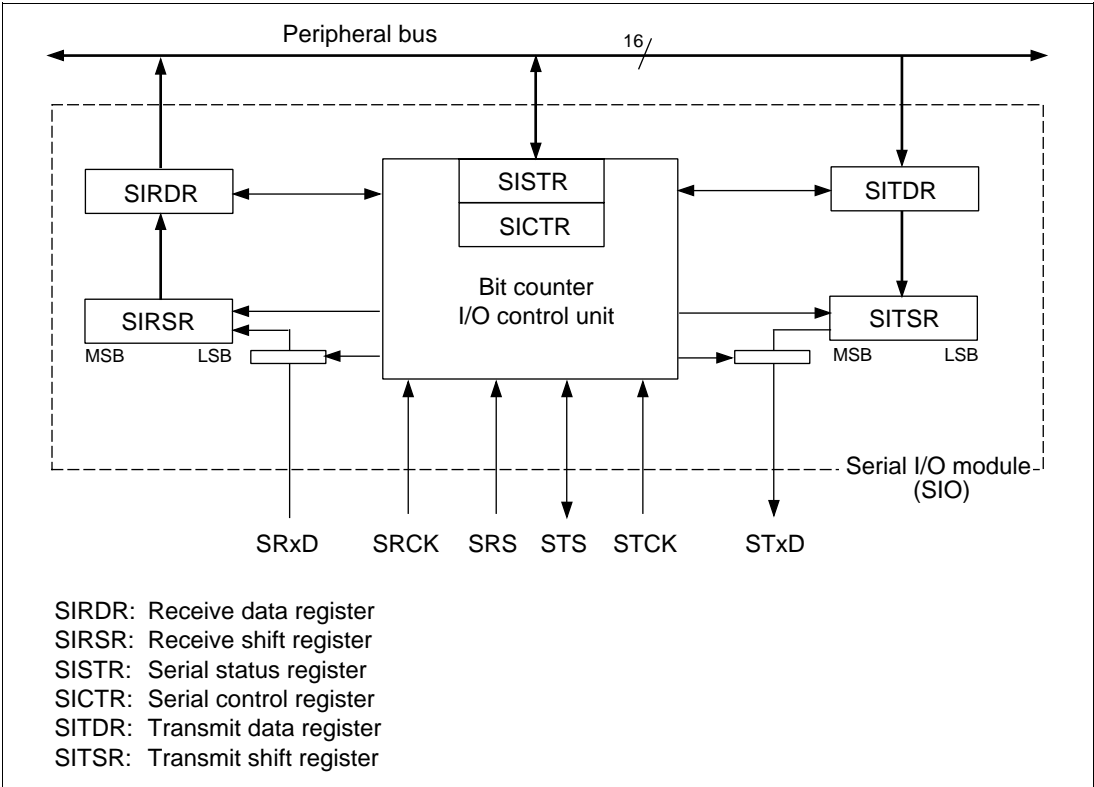

Figure 16.1 SIO Block Diagram

Table 16.1 shows the functions of the external pins. As the channels are independent, the channel numbers are omitted from the signal names in the rest of this section.

Table 16.1 Serial I/O (SIO) External Pins

Channel	Name	Pin	I/O	Function
1	Serial receive data input pin	SRxD1	Input	Serial data input port 1
	Serial receive clock input pin	SRCK1	Input	Serial receive clock port 1
	Serial reception synchronization input pin	SRS1	Input	Serial reception synchronization input port 1
	Serial transmit data output pin	STxD1	Output	Serial data output port 1
	Serial transmit clock input pin	STCK1	Input	Serial transmit clock port 1
	Serial transmission synchronization input/output pin	STS1	I/O	Serial transmission synchronization input/output port 1
2	Serial receive data input pin	SRxD2	Input	Serial data input port 2
	Serial receive clock input pin	SRCK2	Input	Serial receive clock port 2
	Serial reception synchronization input pin	SRS2	Input	Serial reception synchronization input port 2
	Serial transmit data output pin	STxD2	Output	Serial data output port 2
	Serial transmit clock input pin	STCK2	Input	Serial transmit clock port 2
	Serial transmission synchronization input/output pin	STS2	I/O	Serial transmission synchronization input/output port 2

Note: In a reset, all pins are initialized to the high-impedance state.

16.2 Register Configuration

Table 16.2 shows the SIO's registers. As the channels are independent, the channel numbers are omitted from the signal names in the rest of this section.

Table 16.2 Register Configuration

Channel	Register	Abbrevia- tion	R/W	Initial Value	Address	Access Size (Bits)
1	Receive shift register 1	SIRSR1	—	—	—	—
	Receive data register 1	SIRDR1	R	H'0000	H'FFFFFFC10	8, 16, 32
	Transmit shift register 1	SITSR1	—	—	—	—
	Transmit data register 1	SITDR1	R/W	H'0000	H'FFFFFFC12	8, 16, 32
	Serial control register 1	SICTR1	R/W	H'0000	H'FFFFFFC14	8, 16, 32
	Serial status register 1	SISTR1	R/(W)*	H'0002	H'FFFFFFC16	8, 16, 32
2	Receive shift register 2	SIRSR2	—	—	—	—
	Receive data register 2	SIRDR2	R	H'0000	H'FFFFFFC20	8, 16, 32
	Transmit shift register 2	SITSR2	—	—	—	—
	Transmit data register 2	SITDR2	R/W	H'0000	H'FFFFFFC22	8, 16, 32
	Serial control register 2	SICTR2	R/W	H'0000	H'FFFFFFC24	8, 16, 32
	Serial status register 2	SISTR2	R/(W)*	H'0002	H'FFFFFFC26	8, 16, 32

Note: * Only 0 should be written, to clear flags (after reading 1 from the flag).

16.2.1 Receive Shift Register (SIRSR)

Bit:	15	14	13	...	3	2	1	0
	<input type="text"/>	<input type="text"/>	<input type="text"/>	...	<input type="text"/>	<input type="text"/>	<input type="text"/>	<input type="text"/>
Initial value:	—	—	—	...	—	—	—	—
R/W:	—	—	—	...	—	—	—	—

SIRSR is a 16-bit register used to receive serial data. The data is fetched in MSB first from the SRxD pin in synchronization with the fall of the serial receive clock (SRCK), and is shifted into SIRSR. The data length is set by the transmit/receive data length select bit (DL) in the corresponding serial control register (SICTR). When data transfer to SIRSR is completed, the data contents are automatically transferred to the receive data register (SIRD R), and the receive data register full flag (RDRF) is set in the serial status register (SISTR).

If the next data word input operation ends before the RDRF flag is cleared, an overrun error occurs, the receive overrun error flag (RERR) is set in SISTR, and an overrun error signal is sent to the interrupt controller (INTC). The data in SIRSR overwrites the data in SIRD R.

16.2.2 Receive Data Register (SIRD R)

Bit:	15	14	13	...	3	2	1	0
	<input type="text"/>	<input type="text"/>	<input type="text"/>	...	<input type="text"/>	<input type="text"/>	<input type="text"/>	<input type="text"/>
Initial value:	0	0	0	...	0	0	0	0
R/W:	R	R	R	...	R	R	R	R

SIRD R is a 16-bit register that stores serial receive data. When data is transferred from SIRSR to SIRD R, the receive data register full flag (RDRF) is set in the serial status register (SISTR). If the receive interrupt enable flag (RIE) is set in SICTR, a receive-data-full interrupt (RDFI) request is sent to the interrupt controller (INTC) and the DMA controller (DMAC). When the flag is cleared, this interrupt request signal is not generated. When SIRD R is read by the DMAC, the RDRF flag is cleared automatically. SIRD R is initialized to H'0000 by a reset.

16.2.3 Transmit Shift Register (SITSR)

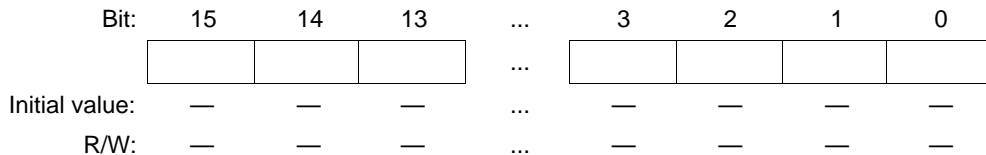

SITSR is a 16-bit register used to transmit serial data. The contents of this register are shifted in MSB-first order in synchronization with the rising edge of the serial transmit clock (STCK), and output from the STxD pin. The transfer data length is set by the transmit/receive data length select bit (DL) in the serial control register (SICTR). When the DL bit is cleared to 0 (8-bit data length), the lower 8 bits of SITDR are output. When the serial transmission synchronization signal (STS) goes high, or the last data transmission ends without the synchronization enable (SE) bit being set in SICTR, the contents of the transmit data register (SITDR) are transferred to SITSR, and if TDRE is 0, TDRE is then set. If output of the next data begins before TDRE is cleared, an overrun error occurs, the transmit overrun error flag (TERR) is set in SISTR, and a transmit overrun error interrupt request is sent to the INTC.

16.2.4 Transmit Data Register (SITDR)

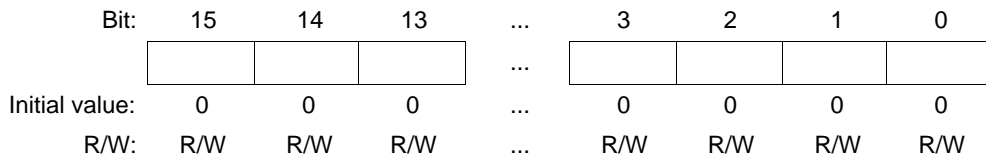

SITDR is a 16-bit register that stores serial transmit data. Data should be written to SITDR when the transmit data register empty flag (TDRE) is set to 1 in SISTR. If data is written to SITDR when TDRE is 0, the previous data will be overwritten. When STS goes high or data output from transmit shift register SITSR ends with the SE bit cleared to 0 in SICTR, the data in SITDR is automatically transferred to SITSR, and if TDRE is 0, TDRE is then set. If the transmit interrupt enable flag (TIE) is set, a transmit-data-empty interrupt (TDEI) request is sent to the INTC and DMAC. When TIE is cleared, this interrupt request is not generated. When the DMAC writes to SITDR, the TDRE flag is cleared automatically. The TDRE flag is set only by hardware. SITDR is initialized to H'0000 by a reset.

16.2.5 Serial Control Register (SICTR)

Bit:	15	14	13	12	11	10	9	8
	—	—	—	—	—	—	—	—
Initial value:	0	0	0	0	0	0	0	0
R/W:	R	R	R	R	R	R	R	R
Bit:	7	6	5	4	3	2	1	0
	—	TM	SE	DL	TIE	RIE	TE	RE
Initial value:	0	0	0	0	0	0	0	0
R/W:	R	R/W	R/W	R/W	R/W	R/W	R/W	R/W

SICTR is a 16-bit register used to set parameters for serial port control. SICTR is initialized to H'0000 by a reset.

When modifying bit 4, 5, or 6 (TM, SE, or DL), TE and RE should be cleared to 0 beforehand.

Bits 15 to 7—Reserved: These bits are always read as 0. The write value should always be 0.

Bit 6—Transfer Mode Control (TM): Specifies whether the transmission synchronization signal is to be input from an external source or generated internally by the chip. When this flag is cleared, the transmission synchronization signal is STS pin input. When this flag is set, the transmission synchronization signal is generated by the chip, and is output to an external device from the STS pin. This bit does not affect reception.

Bit 6: TM	Description
0	External signal input from STS pin is used as transmission start indication (Initial value)
1	Internal signal output from STS pin is used as transmission start indication

Bit 5—Synchronization Signal Enable (SE): Specifies whether the synchronization signals are to be used for all serial data transfers, or only for the first transfer.

When this bit is cleared to 0, the synchronization signals (SRS and STS) are necessary only for the first data transfer, and are not required for subsequent transfers. When this bit is set to 1, the synchronization signals are necessary for all data transfers.

Bit 5: SE	Description
0	Continuous mode: SRS and STS are used only for the first data transfer (Initial value)
1	Interval mode: SRS and STS are used for all data transfers

Bit 4—Transmit/Receive Data Length Select (DL): Specifies the serial I/O module’s transfer data length. The initial value of this bit is 0, indicating an 8-bit data length. When an 8-bit data length is specified, the lower 8 bits of each I/O register are used.

Bit 4: DL	Description
0	8-bit transfer data length (Initial value)
1	16-bit transfer data length

Bit 3—Transmit Interrupt Enable (TIE): Enables the transmit-data-empty interrupt. The initial value of this bit is 0.

Bit 3: TIE	Description
0	Transmit interrupt disabled (Initial value)
1	Transmit interrupt enabled

Bit 2—Receive Interrupt Enable (RIE): Enables the receive-data-full interrupt. The initial value of this bit is 0.

Bit 2: RIE	Description
0	Receive interrupt disabled (Initial value)
1	Receive interrupt enabled

Bit 1—Transmit Enable (TE): Enables data transmission. When this flag is cleared, the STxD, STCK, and STS pins go to the high-impedance state.

Bit 1: TE	Description
0	Transmission disabled: STxD, STCK, and STS pins go to high-impedance state (Initial value)
1	Transmission enabled

Bit 0—Receive Enable (RE): Enables data reception. When this flag is cleared, the SRxD, SRCK, and SRS pins go to the high-impedance state.

Bit 0: RE	Description
0	Reception disabled: SRxD, SRCK, and SRS pins go to high-impedance state (Initial value)
1	Reception enabled

16.2.6 Serial Status Register (SISTR)

Bit:	15	14	...	4	3	2	1	0
	—	—	...	—	TERR	RERR	TDRE	RDRF
Initial value:	0	0	...	0	0	0	1	0
R/W:	R	R	...	R	R/(W)*	R/(W)*	R/(W)*	R/(W)*

Note: * Only 0 should be written, to clear the flag.

SISTR is a 16-bit register that indicates the status of the serial I/O module. SISTR is initialized to H'0002 by a reset.

Bits 15 to 4—Reserved: These bits are always read as 0. The write value should always be 0.

Bit 3—Transmit Underrun Error (TERR): Flag that indicates the occurrence of a transmit underrun.

Bit 3: TERR	Description
0	Transmission is in progress, or has ended normally (Initial value) [Clearing conditions] <ul style="list-style-type: none"> When 0 is written to the TERR bit after reading TERR = 1 When the processor enters the reset state
1	A transmit underrun error has occurred TERR is set to 1 if data transmission is started while TDRE = 1

Bit 2—Receive Overrun Error (RERR): Flag that indicates the occurrence of a receive overrun.

Bit 2: RERR	Description
0	Reception is in progress, or has ended normally (Initial value) [Clearing conditions] <ul style="list-style-type: none"> When 0 is written to the RERR bit after reading RERR = 1 When the processor enters the reset state
1	A receive overrun error has occurred RERR is set to 1 if data reception ends while RDRF = 1

Bit 1—Transmit Data Register Empty (TDRE): Flag that indicates that the SITDR register is empty and the next data can be written.

Bit 1: TDRE	Description
0	SITDR transmit data is valid [Clearing conditions] <ul style="list-style-type: none">• When 0 is written to the TDRE bit after reading TDRE = 1• When the DMAC writes data to SITDR
1	SITDR transmit data is invalid (Initial value) TDRE is set to 1 in the following cases: <ul style="list-style-type: none">• When data is transferred from SITDR to SITSR• When the TE bit is cleared to 0 in the serial control register (SICTR)• When the processor enters the reset state

Bit 0—Receive Data Register Full (RDRF): Flag that indicates that SIRDR receive data is waiting.

Bit 0: RDRF	Description
0	SIRDR receive data is invalid (Initial value) [Clearing conditions] <ul style="list-style-type: none">• When the DMAC reads data from SIRDR• When 1 is read from RDRF and 0 is written• When the RE bit is cleared to 0 in the serial control register (SICTR)• When the processor enters the reset state
1	SIRDR receive data is valid RDRF is set to 1 when serial data reception ends normally and the data is transferred from SIRSRS to SIRDR

16.3 Operation

16.3.1 Input

Figure 16.2 shows interval transfer mode (SE set to 1 in SICTR), and figure 16.3 shows continuous transfer mode (SE cleared to 0 in SICTR).

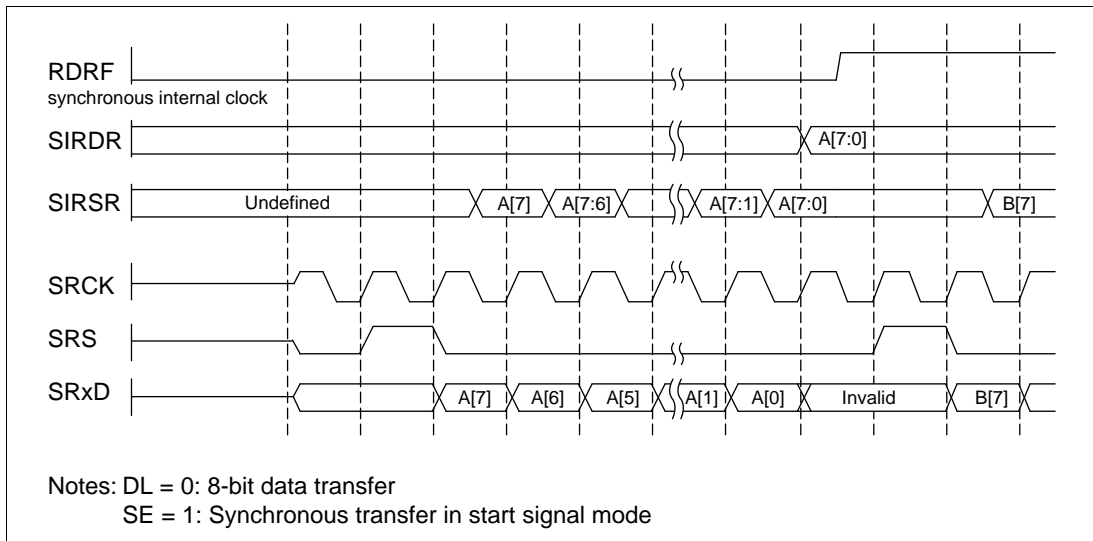

Figure 16.2 Reception: Interval Transfer Mode

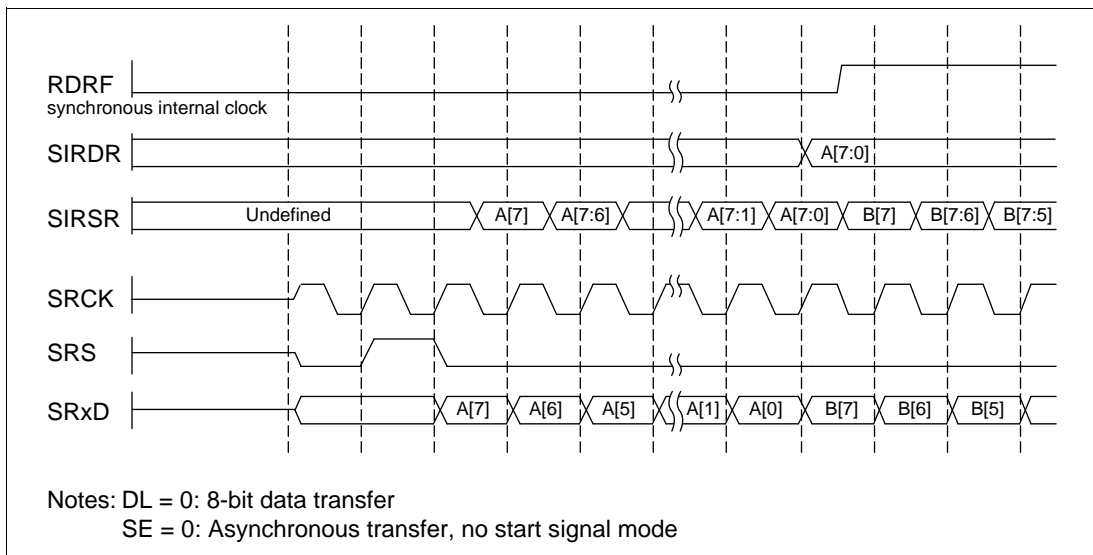

Figure 16.3 Reception: Continuous Transfer Mode

16.3.2 Output

Figure 16.4 shows interval transfer mode (SE set to 1 in SICTR) when TM is cleared to 0 in SICTR.

Figure 16.5 shows continuous transfer mode (SE cleared to 0 in SICTR) when TM is cleared to 0 in SICTR.

Figure 16.6 shows interval transfer mode (SE set to 1 in SICTR) when TM is set to 1 in SICTR.

Figure 16.7 shows continuous transfer mode (SE cleared to 0 in SICTR) when TM is set to 1 in SICTR.

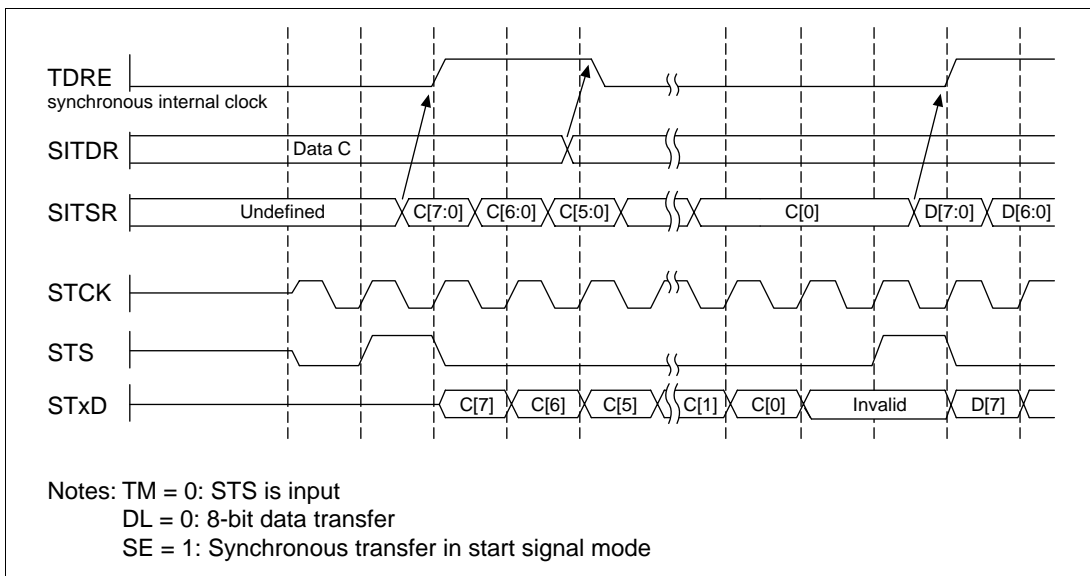
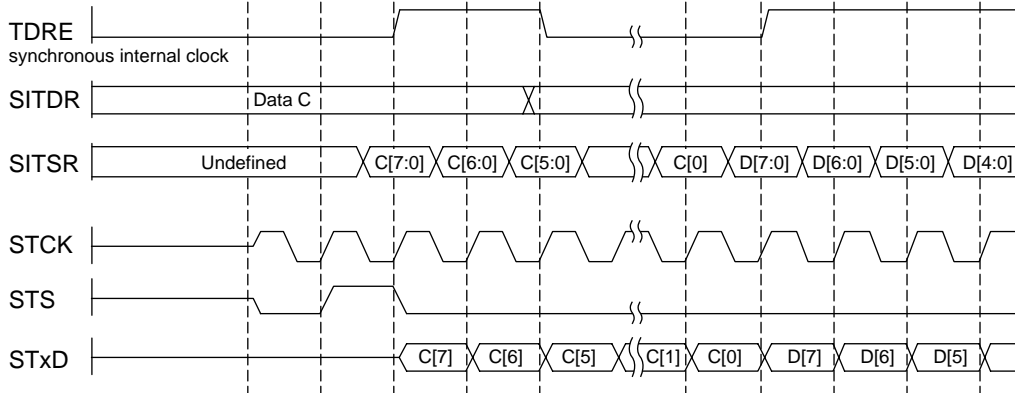
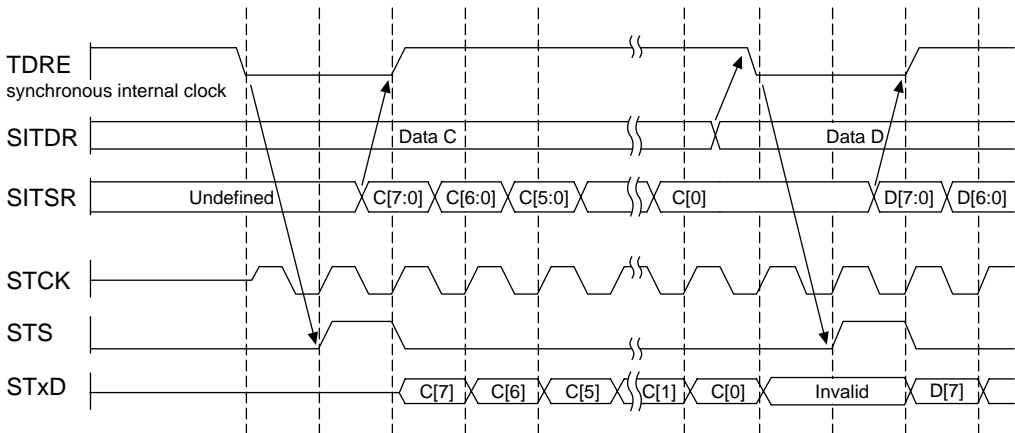

Figure 16.4 Transmission: Interval Transfer Mode (TM = 0 Mode)



Notes: TM = 0: STS is input
 DL = 0: 8-bit data transfer
 SE = 0: Asynchronous transfer, no start signal mode

Figure 16.5 Transmission: Continuous Transfer Mode (TM = 0 Mode)



Notes: TM = 1: STS is output
 DL = 0: 8-bit data transfer
 SE = 1: Synchronous transfer in start signal mode

Figure 16.6 Transmission: Interval Transfer Mode (TM = 1 Mode)

16.4 SIO Interrupt Sources and DMAC

Each SIO channel has four interrupt sources: the receive-overflow-error interrupt (RERI) request, transmit-underrun-error interrupt (TERI) request, receive-data-full interrupt (RDFI) request, and transmit-data-empty interrupt (TDEI) request. Table 16.3 shows the interrupt sources and their relative priorities. The RDFI and TDEI interrupts are enabled by the RIE and TIE bits, respectively, in SICTR. The RERI and TERI interrupts cannot be disabled.

An RDFI interrupt request is generated when the RDRF bit is set to 1 in SISTR. RDFI can activate the DMAC controller (DMAC) to read the data in SIRDR. RDRF is cleared to 0 automatically when the DMAC reads data from SIRDR.

A TDEI interrupt request is generated when the TDRE bit is set to 1 in SISTR. TDEI can activate the DMAC to write the next data to SITDR. TDRE is cleared to 0 automatically when the DMAC writes data to SITDR.

When TDEI and RDFI interrupt requests are handled by the DMAC, and not by the interrupt controller, a low priority level should be given to interrupts from the SIO to prevent the interrupt controller from operating.

When the RERR bit is set to 1 in SISTR, an RERI interrupt request is generated.

When the TERR bit is set to 1 in SISTR, a TERI interrupt request is generated.

Channel interrupt priority levels are set by means of the IRPE register, as described in section 5, Interrupt Controller (INTC).

Table 16.3 SIO Interrupt Sources

Interrupt Source	Description	DMAC Activation	Priority
RERI	Receive overrun error (RERR)	Not possible	High
TERI	Transmit underrun error (TERR)	Not possible	↑
RDFI	Receive data register full (RDRF)	Possible	↓
TDEI	Transmit data register empty (TDRE)	Possible	Low

Section 17 16-Bit Timer Pulse Unit (TPU)

17.1 Overview

An on-chip 16-bit timer pulse unit (TPU) is provided that comprises three 16-bit timer channels.

17.1.1 Features

The TPU has the following features:

- Maximum 8-pulse input/output
- A total of eight timer general registers (TGRs) are provided (four for channel 0 and two each for channels 1, and 2).
 - Each register can be set independently as an output compare/input capture register.
 - TGRC and TGRD for channel 0 can be used as buffer registers
- Choice of seven or eight counter input clocks for each channel
- The following operations can be set for each channel:
 - Waveform output by compare match: Selection of 0, 1, or toggle output
 - Input capture function: Choice of rising edge, falling edge, or both edge detection
 - Counter clear operation: Counter clearing possible by compare match or input capture
 - Synchronous operation: Multiple timer counters (TCNT) can be written to simultaneously simultaneous clearing by compare match and input capture possible register simultaneous input/output possible by counter synchronous operation
 - PWM mode: Any PWM output duty can be set maximum of 7-phase PWM output possible by combination with synchronous operation
- Buffer operation settable for channel 0
 - Input capture register double-buffering possible
 - Automatic rewriting of output compare register possible
- Phase counting mode settable independently for each of channels 1, and 2
 - Two-phase encoder pulse up/down-count possible
- Fast access via internal 16-bit bus
 - Fast access is possible via a 16-bit bus interface
- 13 interrupt sources
 - For channel 0 four compare match/input capture dual-function interrupts and one overflow interrupt can be requested independently
 - For channels 1, and 2, two compare match/input capture dual-function interrupts, one overflow interrupt, and one underflow interrupt can be requested independently

- Automatic transfer of register data
 - Block transfer, 1-word data transfer, and 1-byte data transfer possible by direct memory access controller (DMAC) activation

Table 17.1 lists the functions of the TPU.

Table 17.1 TPU Functions

Item	Channel 0	Channel 1	Channel 2
Count clock	P ϕ /1 P ϕ /4 P ϕ /16 P ϕ /64 TCLKA TCLKB TCLKC TCLKD	P ϕ /1 P ϕ /4 P ϕ /16 P ϕ /64 P ϕ /256 TCLKA TCLKB	P ϕ /1 P ϕ /4 P ϕ /16 P ϕ /64 P ϕ /1024 TCLKA TCLKB TCLKC
General registers	TGR0A TGR0B	TGR1A TGR1B	TGR2A TGR2B
General registers/ buffer registers	TGR0C TGR0D	—	—
I/O pins	TIOCA0 TIOCB0 TIOCC0 TIOCD0	TIOCA1 TIOCB1	TIOCA2 TIOCB2
Counter clear function	TGR compare match or input capture	TGR compare match or input capture	TGR compare match or input capture
Compare match output	0 output	O	O
	1 output	O	O
	Toggle output	O	O
Input capture function	O	O	O
Synchronous operation	O	O	O
PWM mode	O	O	O
Phase counting mode	—	O	O
Buffer operation	O	—	—

Notes: O : Possible

— : Not possible

Table 17.1 TPU Functions (cont)

Item	Channel 0	Channel 1	Channel 2
DMAC activation	TGR compare match or input capture	—	—
Interrupt sources	5 sources <ul style="list-style-type: none">• Compare match or input capture 0A• Compare match or input capture 0B• Compare match or input capture 0C• Compare match or input capture 0D• Overflow	4 sources <ul style="list-style-type: none">• Compare match or input capture 1A• Compare match or input capture 1B• Overflow• Underflow	4 sources <ul style="list-style-type: none">• Compare match or input capture 2A• Compare match or input capture 2B• Overflow• Underflow

Note: — : Not possible

17.1.2 Block Diagram

Figure 17.1 shows a block diagram of the TPU.

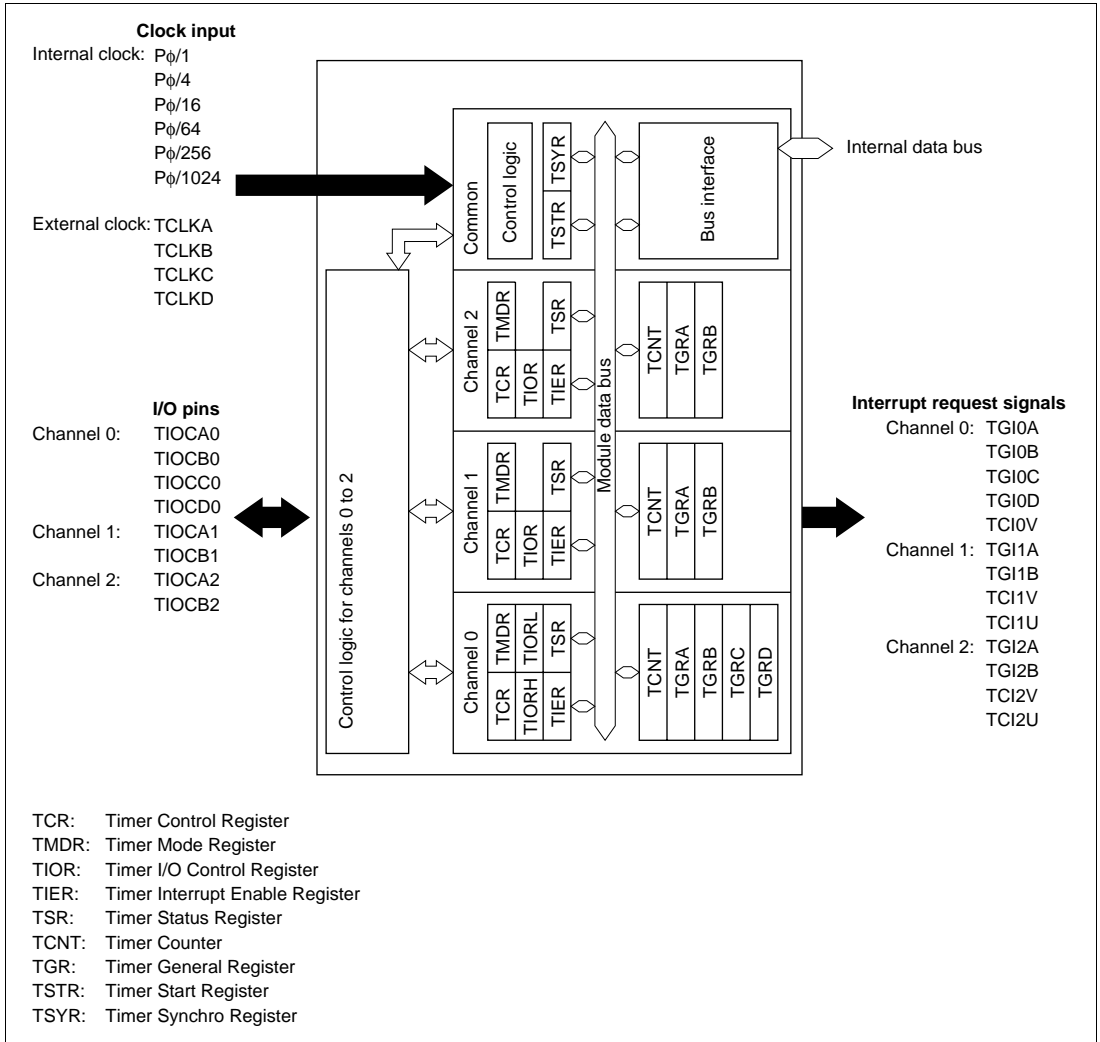

Figure 17.1 TPU Block Diagram

17.1.3 Pin Configuration

Table 17.2 shows the pin configuration of the TPU.

Table 17.2 Pin Configuration

Channel	Name	Abbreviation	I/O	Function
All	Clock input A	TCLKA	Input	External clock A input pin (Channel 1 phase counting mode A phase input)
	Clock input B	TCLKB	Input	External clock B input pin (Channel 1 phase counting mode B phase input)
	Clock input C	TCLKC	Input	External clock C input pin (Channel 2 phase counting mode A phase input)
	Clock input D	TCLKD	Input	External clock D input pin (Channel 2 phase counting mode B phase input)
0	Input capture/output compare match A0	TIOCA0	I/O	TGR0A input capture input/output compare output/PWM output pin
	Input capture/output compare match B0	TIOCB0	I/O	TGR0B input capture input/output compare output/PWM output pin
	Input capture/output compare match C0	TIOCC0	I/O	TGR0C input capture input/output compare output/PWM output pin
	Input capture/output compare match D0	TIOCD0	I/O	TGR0D input capture input/output compare output/PWM output pin
1	Input capture/output compare match A1	TIOCA1	I/O	TGR1A input capture input/output compare output/PWM output pin
	Input capture/output compare match B1	TIOCB1	I/O	TGR1B input capture input/output compare output/PWM output pin
2	Input capture/output compare match A2	TIOCA2	I/O	TGR2A input capture input/output compare output/PWM output pin
	Input capture/output compare match B2	TIOCB2	I/O	TGR2B input capture input/output compare output/PWM output pin

17.1.4 Register Configuration

Table 17.3 shows the register configuration of the TPU.

Table 17.3 Register Configuration

Channel	Name	Abbreviation	R/W	Initial Value	Address	Access size (Bits)
0	Timer control register 0	TCR0	R/W	H'00	H'FFFFFFC50	8,16
	Timer mode register 0	TMDR0	R/W	H'C0	H'FFFFFFC51	8,16
	Timer I/O control register 0H	TIOR0H	R/W	H'00	H'FFFFFFC52	8,16
	Timer I/O control register 0L	TIOR0L	R/W	H'00	H'FFFFFFC53	8,16
	Timer interrupt enable register 0	TIER0	R/W	H'40	H'FFFFFFC54	8,16
	Timer status register 0	TSR0	R/(W)*	H'C0	H'FFFFFFC55	8,16
	Timer counter 0	TCNT0	R/W	H'0000	H'FFFFFFC56	16
	Timer general register 0A	TGR0A	R/W	H'FFFF	H'FFFFFFC58	16
	Timer general register 0B	TGR0B	R/W	H'FFFF	H'FFFFFFC5A	16
	Timer general register 0C	TGR0C	R/W	H'FFFF	H'FFFFFFC5C	16
	Timer general register 0D	TGR0D	R/W	H'FFFF	H'FFFFFFC5E	16
1	Timer control register 1	TCR1	R/W	H'00	H'FFFFFFC60	8,16
	Timer mode register 1	TMDR1	R/W	H'C0	H'FFFFFFC61	8,16
	Timer I/O control register 1	TIOR1	R/W	H'00	H'FFFFFFC62	8,16
	Timer interrupt enable register 1	TIER1	R/W	H'40	H'FFFFFFC64	8,16
	Timer status register 1	TSR1	R/(W)*	H'C0	H'FFFFFFC65	8,16
	Timer counter 1	TCNT1	R/W	H'0000	H'FFFFFFC66	16
	Timer general register 1A	TGR1A	R/W	H'FFFF	H'FFFFFFC68	16
	Timer general register 1B	TGR1B	R/W	H'FFFF	H'FFFFFFC6A	16

Table 17.3 Register Configuration (cont)

Channel	Name	Abbreviation	R/W	Initial Value	Address	Access size (Bits)
2	Timer control register 2	TCR2	R/W	H'00	H'FFFFFFC70	8, 16
	Timer mode register 2	TMDR2	R/W	H'C0	H'FFFFFFC71	8, 16
	Timer I/O control register 2	TIOR2	R/W	H'00	H'FFFFFFC72	8, 16
	Timer interrupt enable register 2	TIER2	R/W	H'40	H'FFFFFFC74	8, 16
	Timer status register 2	TSR2	R/(W)*	H'C0	H'FFFFFFC75	8, 16
	Timer counter 2	TCNT2	R/W	H'0000	H'FFFFFFC76	16
	Timer general register 2A	TGR2A	R/W	H'FFFF	H'FFFFFFC78	16
	Timer general register 2B	TGR2B	R/W	H'FFFF	H'FFFFFFC7A	16
All	Timer start register	TSTR	R/W	H'00	H'FFFFFFC40	8, 16
	Timer synchro register	TSYR	R/W	H'00	H'FFFFFFC41	8, 16

Note: * Only 0 can be written, to clear the flags.

17.2 Register Descriptions

17.2.1 Timer Control Register (TCR)

Channel 0: TCR0

Bit:	7	6	5	4	3	2	1	0
	CCLR2	CCLR1	CCLR0	CKEG1	CKEG0	TPSC2	TPSC1	TPSC0
Initial value:	0	0	0	0	0	0	0	0
R/W:	R/W	R/W	R/W	R/W	R/W	R/W	R/W	R/W

Channel 1: TCR1

Channel 2: TCR2

Bit:	7	6	5	4	3	2	1	0
	—	CCLR1	CCLR0	CKEG1	CKEG0	TPSC2	TPSC1	TPSC0
Initial value:	0	0	0	0	0	0	0	0
R/W:	R	R/W	R/W	R/W	R/W	R/W	R/W	R/W

The TCR registers are 8-bit registers that control the TCNT channels. The TPU has three TCR registers, one for each of channels 0 to 2. The TCR registers are initialized to H'00 by a reset.

TCNT operation should be stopped when making TCR settings.

Bits 7 to 5—Counter Clear 2 to 0 (CCLR2 to CCLR0): These bits select the TCNT counter clearing source.

Channel	Bit 7: CCLR2	Bit 6: CCLR1	Bit 5: CCLR0	Description
0	0	0	0	TCNT clearing disabled (Initial value)
			1	TCNT cleared by TGRA compare match/input capture
			0	TCNT cleared by TGRB compare match/input capture
			1	TCNT cleared by counter clearing for another channel performing synchronous clearing/synchronous operation * ¹
1	1	0	0	TCNT clearing disabled
			1	TCNT cleared by TGRC compare match/input capture * ²
			0	TCNT cleared by TGRD compare match/input capture * ²
			1	TCNT cleared by counter clearing for another channel performing synchronous clearing/synchronous operation * ¹

Channel	Bit 7: Reserved* ³	Bit 6: CCLR1	Bit 5: CCLR0	Description
1, 2	0	0	0	TCNT clearing disabled (Initial value)
			1	TCNT cleared by TGRA compare match/input capture
			0	TCNT cleared by TGRB compare match/input capture
			1	TCNT cleared by counter clearing for another channel performing synchronous clearing/synchronous operation * ¹

Notes: *¹ Synchronous operation setting is performed by setting the SYNC bit in TSYR to 1.

*² When TGRC or TGRD is used as a buffer register, TCNT is not cleared because the buffer register setting has priority, and compare match/input capture does not occur.

*³ Bit 7 is reserved in channels 1 and 2. It is always read as 0. The write value should always be 0.

Bits 4 and 3—Clock Edge 1 and 0 (CKEG1, CKEG0): These bits select the input clock edge. When a both-edges count is selected, a clock divided by two from the input clock can be selected. (e.g. $P\phi/4$ both edges = $P\phi/2$ rising edge). If phase counting mode is used on channels 1, and 2, this setting is ignored and the phase counting mode setting has priority.

Bit 4: CKEG1	Bit 3: CKEG0	Description
0	0	Count at rising edge (Initial value)
	1	Count at falling edge
1	—	Count at both edges

Note: Internal clock edge selection is valid when the input clock is $P\phi/4$ or slower. If $P\phi/1$ is selected for the input clock, this setting is ignored and a rising-edge count is selected.

Bits 2 to 0—Time Prescaler 2 to 0 (TPSC2 to TPSC0): These bits select the TCNT counter clock. The clock source can be selected independently for each channel. Table 17.4 shows the clock sources that can be set for each channel.

Table 17.4 TPU Clock Sources

Channel	Internal Clock						External Clock			
	$P\phi/1$	$P\phi/4$	$P\phi/16$	$P\phi/64$	$P\phi/256$	$P\phi/1024$	TCLKA	TCLKB	TCLKC	TCLKD
0	○	○	○	○			○	○	○	○
1	○	○	○	○	○		○	○		
2	○	○	○	○		○	○	○	○	

Notes: ○: Setting

Blank: No setting

Channel	Bit 2: TPSC2	Bit 1: TPSC1	Bit 0: TPSC0	Description	
0	0	0	0	Internal clock: counts on P ϕ /1 (Initial value)	
			1	Internal clock: counts on P ϕ /4	
			1	0	Internal clock: counts on P ϕ /16
				1	Internal clock: counts on P ϕ /64
	1	0	0	External clock: counts on TCLKA pin input	
			1	External clock: counts on TCLKB pin input	
			1	0	External clock: counts on TCLKC pin input
				1	External clock: counts on TCLKD pin input

Channel	Bit 2: TPSC2	Bit 1: TPSC1	Bit 0: TPSC0	Description	
1	0	0	0	Internal clock: counts on P ϕ /1 (Initial value)	
			1	Internal clock: counts on P ϕ /4	
			1	0	Internal clock: counts on P ϕ /16
				1	Internal clock: counts on P ϕ /64
	1	0	0	External clock: counts on TCLKA pin input	
			1	External clock: counts on TCLKB pin input	
			1	0	Internal clock: counts on P ϕ /256
				1	Setting prohibited

Note: This setting is ignored when channel 1 is in phase counting mode.

Channel	Bit 2: TPSC2	Bit 1: TPSC1	Bit 0: TPSC0	Description	
2	0	0	0	Internal clock: counts on P ϕ /1 (Initial value)	
			1	Internal clock: counts on P ϕ /4	
			1	0	Internal clock: counts on P ϕ /16
				1	Internal clock: counts on P ϕ /64
	1	0	0	External clock: counts on TCLKA pin input	
			1	External clock: counts on TCLKB pin input	
			1	0	External clock: counts on TCLKC pin input
				1	Internal clock: counts on P ϕ /1024

Note: This setting is ignored when channel 2 is in phase counting mode.

17.2.2 Timer Mode Register (TMDR)

Channel 0: TMDR0

Bit:	7	6	5	4	3	2	1	0
	—	—	BFB	BFA	MD3	MD2	MD1	MD0
Initial value:	1	1	0	0	0	0	0	0
R/W:	R	R	R/W	R/W	R/W	R/W	R/W	R/W

Channel 1: TMDR1

Channel 2: TMDR2

Bit:	7	6	5	4	3	2	1	0
	—	—	—	—	MD3	MD2	MD1	MD0
Initial value:	1	1	0	0	0	0	0	0
R/W:	R	R	R	R	R/W	R/W	R/W	R/W

The TMDR registers are 8-bit readable/writable registers that are used to set the operating mode for each channel. The TPU has three TMDR registers, one for each channel. The TMDR registers are initialized to H'00 by a reset.

TCNT operation should be stopped when making TMDR settings.

Bits 7 and 6—Reserved: These bits are always read as 1. The write value should always be 1.

Bit 5—Buffer Operation B (BFB): Specifies whether TGRB is to operate in the normal way, or TGRB and TGRD are to be used together for buffer operation. When TGRD is used as a buffer register, TGRD input capture/output compare is not generated.

In channels 1 and 2, which have no TGRD, bit 5 is reserved. It is always read as 0 and cannot be modified.

Bit 5: BFB	Description	
0	TGRB operates normally	(Initial value)
1	TGRB and TGRD used together for buffer operation	

Bit 4—Buffer Operation A (BFA): Specifies whether TGRA is to operate in the normal way, or TGRA and TGRC are to be used together for buffer operation. When TGRC is used as a buffer register, TGRC input capture/output compare is not generated.

In channels 1 and 2, which have no TGRC, bit 4 is reserved. It is always read as 0 and cannot be modified.

Bit 4: BFA	Description
0	TGRA operates normally (Initial value)
1	TGRA and TGRC used together for buffer operation

Bits 3 to 0—Modes 3 to 0 (MD3 to MD0): These bits are used to set the timer operating mode.

Bit 3: MD3* ¹	Bit 2: MD2* ²	Bit 1: MD1	Bit 0: MD0	Description
0	0	0	0	Normal operation (Initial value)
			1	Reserved
		1	0	PWM mode 1
			1	PWM mode 2
	1	0	0	Phase counting mode 1
			1	Phase counting mode 2
		1	0	Phase counting mode 3
			1	Phase counting mode 4
1	*	*	*	—

*: Don't care

Notes: *1 MD3 is a reserved bit. In a write, it should always be written with 0.

*2 Phase counting mode cannot be set for channel 0. In this case, 0 should always be written to MD2.

17.2.3 Timer I/O Control Register (TIOR)

Channel 0: TIOR0H

Channel 1: TIOR1

Channel 2: TIOR2

Bit:	7	6	5	4	3	2	1	0
	IOB3	IOB2	IOB1	IOB0	IOA3	IOA2	IOA1	IOA0
Initial value:	0	0	0	0	0	0	0	0
R/W:	R/W	R/W	R/W	R/W	R/W	R/W	R/W	R/W

Channel 0: TIOR0L

Bit:	7	6	5	4	3	2	1	0
	IOD3	IOD2	IOD1	IOD0	IOC3	IOC2	IOC1	IOC0
Initial value:	0	0	0	0	0	0	0	0
R/W:	R/W	R/W	R/W	R/W	R/W	R/W	R/W	R/W

Note: When TGRC or TGRD is designated for buffer operation, this setting is invalid and the register operates as a buffer register.

The TIOR registers are 8-bit registers that control the TGR registers. The TPU has four TIOR registers, two for channel 0 and one each for channels 1, and 2. The TIOR registers are initialized to H'00 by a reset.

Note that TIOR is affected by the TMDR setting.

The initial output specified by TIOR becomes valid when the counter is halted (i.e. when the CST bit is cleared to 0 in TSTR). In PWM mode 2, the output at the point at which the counter is cleared to 0 is specified.

Bits 7 to 4— I/O Control B3 to B0 (IOB3 to IOB0)

I/O Control D3 to D0 (IOD3 to IOD0):

Bits IOB3 to IOB0 specify the function of TGRB.

Bits IOD3 to IOD0 specify the function of TGRD.

TIOR0H

Channel	Bit 7: Bit 6: Bit 5: Bit 4:				Description		
	IOB3	IOB2	IOB1	IOB0			
0	0	0	0	0	TGR0B is Output disabled (Initial value)		
				1	output	Initial output is 0	0 output at compare match
				0	compare register	output	1 output at compare match
				1		Toggle output at compare match	
	1	0	0	0	Output disabled		
				1	Initial output is 1	0 output at compare match	
				0	output	1 output at compare match	
				1		Toggle output at compare match	
1	0	0	0	TGR0B is Capture input			
			1	input source is	Input capture at rising edge		
			*	capture register	TIOCB0 pin	Input capture at falling edge	
			*		Input capture at both edges		
1	*	*	*	Setting prohibited			

*: Don't care

TIOR0L

Channel	Bit 7: Bit 6: Bit 5: Bit 4:				Description
	IOD3	IOD2	IOD1	IOD0	
0	0	0	0	0	TGR0D is Output disabled (Initial value)
				1	output Initial output is 0
				0	0 output at compare match
				1	1 output at compare match
	1	0	0	0	compare register*1
				1	Toggle output at compare match
				0	Output disabled
				1	Initial output is 1
				0	0 output at compare match
				1	1 output at compare match
1	0	0	0	TGR0D is Capture input	
			1	input source is	
			*	TIOCD0 pin	
			*	Input capture at both edges	
			*	Setting prohibited	

*: Don't care

Note: *1 When the BFB bit in TMDR0 is set to 1 and TGR0D is used as a buffer register, this setting is invalid and input capture/output compare is not generated.

TIOR1

Channel	Bit 7:	Bit 6:	Bit 5:	Bit 4:	Description		
	IOB3	IOB2	IOB1	IOB0			
1	0	0	0	0	TGR1B is output compare register	Output disabled	(Initial value)
				1		Initial output is 0	0 output at compare match
				0		output	1 output at compare match
				1		Toggle output at compare match	
	1	0	0	0	TGR1B is output compare register	Output disabled	
				1		Initial output is 1	0 output at compare match
				0		output	1 output at compare match
				1		Toggle output at compare match	
	1	0	0	0	TGR1B is capture register	Capture input source is TIOCB1 pin	Input capture at rising edge
				1		input	Input capture at falling edge
				*		capture register	Input capture at both edges
				*		Setting prohibited	

*: Don't care

TIOR2

Channel	Bit 7:	Bit 6:	Bit 5:	Bit 4:	Description		
	IOB3	IOB2	IOB1	IOB0			
2	0	0	0	0	TGR2B is output compare register	Output disabled	(Initial value)
				1		Initial output is 0	0 output at compare match
				0		output	1 output at compare match
				1		Toggle output at compare match	
	1	0	0	0	TGR2B is output compare register	Output disabled	
				1		Initial output is 1	0 output at compare match
				0		output	1 output at compare match
				1		Toggle output at compare match	
	1	*	0	0	TGR2B is capture register	Capture input source is TIOCB2 pin	Input capture at rising edge
				1		input	Input capture at falling edge
				*		capture register	Input capture at both edges
				*			

*: Don't care

Bits 3 to 0— I/O Control A3 to A0 (IOA3 to IOA0)

I/O Control C3 to C0 (IOC3 to IOC0):

IOA3 to IOA0 specify the function of TGRA.

IOC3 to IOC0 specify the function of TGRC.

TIOR0H

Channel	Bit 3: Bit 2: Bit 1: Bit 0:				Description
	IOA3	IOA2	IOA1	IOA0	
0	0	0	0	0	TGRA0 is Output disabled (Initial value)
				1	output
				0	Initial output is 0
				1	output at compare match
	1	0	1	0	compare register
				1	output
				0	1 output at compare match
				1	Toggle output at compare match
1	0	0	0	Output disabled	
			1	Initial output is 1	
			0	output	
			1	0 output at compare match	
1	0	1	0	1 output at compare match	
			1	Toggle output at compare match	
			0	TGRA0 is Capture input	
			1	input source is	
1	0	0	*	TIOCA0 pin	
			*	Input capture at rising edge	
			*	Input capture at falling edge	
			*	Input capture at both edges	
1	1	*	*	Setting prohibited	

*: Don't care

TIOR0L

Channel	Bit 3: Bit 2: Bit 1: Bit 0:				Description
	IOC3	IOC2	IOC1	IOC0	
0	0	0	0	0	TGR0C is Output disabled (Initial value)
				1	output Initial output is 0 0 output at compare match
				0	compare output 1 output at compare match
				1	register* ¹ Toggle output at compare match
	1	0	0	0	Output disabled
				1	Initial output is 1 0 output at compare match
				0	output 1 output at compare match
				1	Toggle output at compare match
1	0	0	0	TGR0C is Capture input Input capture at rising edge	
			1	input source is Input capture at falling edge	
			*	capture TIOCC0 pin Input capture at both edges	
			*	register* ¹ Setting prohibited	

*: Don't care

Note: *¹ When the BFA bit in TMDR0 is set to 1 and TGR0C is used as a buffer register, this setting is invalid and input capture/output compare is not generated.

TIOR1

Channel	Bit 3: Bit 2: Bit 1: Bit 0:				Description
	IOA3	IOA2	IOA1	IOA0	
1	0	0	0	0	TGR1A is Output disabled (Initial value)
				1	output Initial output is 0
				0	compare 0 output at compare match
				1	register 1 output at compare match
	1	0	0	0	Output disabled
				1	Initial output is 1
				0	output 0 output at compare match
				1	1 output at compare match
	1	0	0	0	TGR1A is Capture input
				1	input source is
				*	capture TIOCA1 pin
				*	register Input capture at both edges
1	*	*	*	Setting prohibited	

*: Don't care

TIOR2

Channel	Bit 3: Bit 2: Bit 1: Bit 0:				Description
	IOA3	IOA2	IOA1	IOA0	
2	0	0	0	0	TGR2A is Output disabled (Initial value)
				1	output Initial output is 0
				0	compare 0 output at compare match
				1	register 1 output at compare match
	1	0	0	0	Output disabled
				1	Initial output is 1
				0	output 0 output at compare match
				1	1 output at compare match
	1	*	0	0	TGR2A is Capture input
				1	input source is
				*	capture TIOCA2 pin
				*	register Input capture at both edges

*: Don't care

17.2.4 Timer Interrupt Enable Register (TIER)

Channel 0: TIER0

Bit:	7	6	5	4	3	2	1	0
	—	—	—	TCIEV	TGIED	TGIEC	TGIEB	TGIEA
Initial value:	0	1	0	0	0	0	0	0
R/W:	R	R	R	R/W	R/W	R/W	R/W	R/W

Channel 1: TIER1

Channel 2: TIER2

Bit:	7	6	5	4	3	2	1	0
	—	—	TCIEU	TCIEV	—	—	TGIEB	TGIEA
Initial value:	0	1	0	0	0	0	0	0
R/W:	R	R	R/W	R/W	R	R	R/W	R/W

The TIER registers are 8-bit registers that control enabling or disabling of interrupt requests for each channel. The TPU has three TIER registers, one for each channel. The TIER registers are initialized to H'40 by a reset.

Bit 7—Reserved: This bit is always read as 0. The write value should always be 0.

Bit 6—Reserved: This bit is always read as 1. The write value should always be 1.

Bit 5—Underflow Interrupt Enable (TCIEU): Enables or disables interrupt requests (TCIU) by the TCFU flag when the TCFU flag in TSR is set to 1 in channels 1 and 2.

In channel 0, bit 5 is reserved. It is always read as 0 and cannot be modified.

Bit 5: TCIEU	Description
0	Interrupt requests (TCIU) by TCFU disabled (Initial value)
1	Interrupt requests (TCIU) by TCFU enabled

Bit 4—Overflow Interrupt Enable (TCIEV): Enables or disables interrupt requests (TCIV) by the TCFV flag when the TCFV flag in TSR is set to 1.

Bit 4: TCIEV	Description
0	Interrupt requests (TCIV) by TCFV disabled (Initial value)
1	Interrupt requests (TCIV) by TCFV enabled

Bit 3—TGR Interrupt Enable D (TGIED): Enables or disables interrupt requests (TGID) by the TGFD bit when the TGFD bit in TSR is set to 1 in channel 0.

In channels 1, and 2, bit 3 is reserved. It is always read as 0 and cannot be modified.

Bit 3: TGIED	Description
0	Interrupt requests (TGID) by TGFD bit disabled (Initial value)
1	Interrupt requests (TGID) by TGFD bit enabled

Bit 2—TGR Interrupt Enable C (TGIEC): Enables or disables interrupt requests (TGIC) by the TGFC bit when the TGFC bit in TSR is set to 1 in channel 0.

In channels 1 and 2, bit 2 is reserved. It is always read as 0 and cannot be modified.

Bit 2: TGIEC	Description
0	Interrupt requests (TGIC) by TGFC bit disabled (Initial value)
1	Interrupt requests (TGIC) by TGFC bit enabled

Bit 1—TGR Interrupt Enable B (TGIEB): Enables or disables interrupt requests (TGIB) by the TGFB bit when the TGFB bit in TSR is set to 1.

Bit 1: TGIEB	Description
0	Interrupt requests (TGIB) by TGFB bit disabled (Initial value)
1	Interrupt requests (TGIB) by TGFB bit enabled

Bit 0—TGR Interrupt Enable A (TGIEA): Enables or disables interrupt requests (TGIA) by the TGFA bit when the TGFA bit in TSR is set to 1.

Bit 0: TGIEA	Description
0	Interrupt requests (TGIA) by TGFA bit disabled (Initial value)
1	Interrupt requests (TGIA) by TGFA bit enabled

17.2.5 Timer Status Register (TSR)

Channel 0: TSR0

Bit:	7	6	5	4	3	2	1	0
	—	—	—	TCFV	TGFD	TGFC	TGFB	TGFA
Initial value:	1	1	0	0	0	0	0	0
R/W:	R	R	R	R/(W)*	R/(W)*	R/(W)*	R/(W)*	R/(W)*

Note: * Only 0 can be written, to clear the flags.

Channel 1: TSR1

Channel 2: TSR2

Bit:	7	6	5	4	3	2	1	0
	TCFD	—	TCFU	TCFV	—	—	TGFB	TGFA
Initial value:	1	1	0	0	0	0	0	0
R/W:	R	R	R/(W)*	R/(W)*	R	R	R/(W)*	R/(W)*

Note: * Only 0 can be written, to clear the flags.

The TSR registers are 8-bit registers that indicate the status of each channel. The TPU has three TSR registers, one for each channel. The TSR registers are initialized to H'C0 by a reset.

Bit 7—Count Direction Flag (TCFD): Status flag that shows the direction in which TCNT counts in channels 1, and 2.

In channel 0, bit 7 is reserved. It is always read as 1 and cannot be modified.

Bit 7: TCFD	Description
0	TCNT counts down
1	TCNT counts up (Initial value)

Bit 6—Reserved: This bit is always read as 0. The write value should always be 0.

Bit 5—Underflow Flag (TCFU): Status flag that indicates that TCNT underflow has occurred when channels 1 and 2 are set to phase counting mode.

In channel 0, bit 5 is reserved. It is always read as 0 and cannot be modified.

Bit 5: TCFU	Description
0	[Clearing condition] (Initial value) When 0 is written to TCFU after reading TCFU = 1
1	[Setting condition] When the TCNT value underflows (changes from H'0000 to H'FFFF)

Bit 4—Overflow Flag (TCFV): Status flag that indicates that TCNT overflow has occurred.

Bit 4: TCFV	Description
0	[Clearing condition] (Initial value) When 0 is written to TCFV after reading TCFV = 1
1	[Setting condition] When the TCNT value overflows (changes from H'FFFF to H'0000)

Bit 3—Input Capture/Output Compare Flag D (TGFD): Status flag that indicates the occurrence of TGRD input capture or compare match in channel 0.

In channels 1 and 2, bit 3 is reserved. It is always read as 0 and cannot be modified.

Bit 3: TGFD	Description
0	[Clearing conditions] (Initial value) <ul style="list-style-type: none"> When DMAC is activated by TGID interrupt while DRCR setting in DMAC is TGI0D When 0 is written to TGFD after reading TGFD = 1
1	[Setting conditions] <ul style="list-style-type: none"> When TCNT = TGRD while TGRD is functioning as output compare register When TCNT value is transferred to TGRD by input capture signal while TGRD is functioning as input capture register

Bit 2—Input Capture/Output Compare Flag C (TGFC): Status flag that indicates the occurrence of TGRC input capture or compare match in channel 0.

In channels 1 and 2, bit 2 is reserved. It is always read as 0 and cannot be modified.

Bit 2: TGFC	Description
0	[Clearing conditions] (Initial value) <ul style="list-style-type: none">• When DMAC is activated by TGIC interrupt while DRCCR setting in DMAC is TGI0C• When 0 is written to TGFC after reading TGFC = 1
1	[Setting conditions] <ul style="list-style-type: none">• When TCNT = TGRC while TGRC is functioning as output compare register• When TCNT value is transferred to TGRC by input capture signal while TGRC is functioning as input capture register

Bit 1—Input Capture/Output Compare Flag B (TGFB): Status flag that indicates the occurrence of TGRB input capture or compare match.

Bit 1: TGFB	Description
0	[Clearing conditions] (Initial value) <ul style="list-style-type: none">• When DMAC is activated by TGIB interrupt while DRCCR setting in DMAC is TGI0B• When 0 is written to TGFB after reading TGFB = 1
1	[Setting conditions] <ul style="list-style-type: none">• When TCNT = TGRB while TGRB is functioning as output compare register• When TCNT value is transferred to TGRB by input capture signal while TGRB is functioning as input capture register

Bit 0—Input Capture/Output Compare Flag A (TGFA): Status flag that indicates the occurrence of TGRA input capture or compare match.

Bit 0: TGFA	Description
0	[Clearing conditions] (Initial value) <ul style="list-style-type: none"> When DMAC is activated by TGIA interrupt while DRCCR setting in DMAC is TGIOA When 0 is written to TGFA after reading TGFA = 1
1	[Setting conditions] <ul style="list-style-type: none"> When TCNT = TGRA while TGRA is functioning as output compare register When TCNT value is transferred to TGRA by input capture signal while TGRA is functioning as input capture register

17.2.6 Timer Counter (TCNT)

Channel 0: TCNT0 (up-counter)

Channel 1: TCNT1 (up/down-counter*)

Channel 2: TCNT2 (up/down-counter*)

Bit:	15	14	13	12	11	10	9	8
Initial value:	0	0	0	0	0	0	0	0
R/W:	R/W	R/W	R/W	R/W	R/W	R/W	R/W	R/W
Bit:	7	6	5	4	3	2	1	0
Initial value:	0	0	0	0	0	0	0	0
R/W:	R/W	R/W	R/W	R/W	R/W	R/W	R/W	R/W

Note: * These counters can be used as up/down-counters only in phase counting mode. In other cases they function as up-counters.

The TCNT registers are 16-bit counters. The TPU has three TCNT counters, one for each channel.

The TCNT counters are initialized to H'0000 by a reset.

The TCNT counters cannot be accessed in 8-bit units; they must always be accessed as a 16-bit unit.

17.2.7 Timer General Register (TGR)

Bit:	15	14	13	12	11	10	9	8
Initial value:	1	1	1	1	1	1	1	1
R/W:	R/W	R/W	R/W	R/W	R/W	R/W	R/W	R/W
Bit:	7	6	5	4	3	2	1	0
Initial value:	1	1	1	1	1	1	1	1
R/W:	R/W	R/W	R/W	R/W	R/W	R/W	R/W	R/W

The TGR registers are 16-bit registers with a dual function as output compare and input capture registers. The TPU has 8 TGR registers, four for channel 0 and two each for channels 1, and 2. TGRC and TGRD for channel 0 can also be designated for operation as buffer registers*. The TGR registers are initialized to H'FFFF by a reset.

The TGR registers cannot be accessed in 8-bit units; they must always be accessed as a 16-bit unit.

Note: * TGR buffer register combinations are TGRA–TGRC and TGRB–TGRD.

17.2.8 Timer Start Register (TSTR)

Bit:	7	6	5	4	3	2	1	0
	—	—	—	—	—	CST2	CST1	CST0
Initial value:	0	0	0	0	0	0	0	0
R/W:	R	R	R	R	R	R/W	R/W	R/W

TSTR is an 8-bit readable/writable register that selects operation/stoppage for channels 0 to 2. TSTR is initialized to H'00 by a reset.

TCNT counter operation should be stopped when setting the operating mode in TMDR or the TCNT count clock in TCR.

Bits 7 to 3—Reserved: These bits are always read as 0. The write value should always be 0.

Bits 2 to 0—Counter Start 2 to 0 (CST2 to CST0): These bits select operation or stoppage for TCNT.

Bit n: CSTn	Description
0	TCNTn count operation is stopped (Initial value)
1	TCNTn performs count operation

Note: n = 2 to 0

If 0 is written to the CST bit during operation with the TIOC pin designated for output, the counter stops, but the TIOC pin output compare output level is retained. If TIOR is written to when the CST bit is cleared to 0, the pin output level will be changed to the set initial output value.

17.2.9 Timer Synchronous Register (TSYR)

Bit:	7	6	5	4	3	2	1	0
	—	—	—	—	—	SYNC2	SYNC1	SYNC0
Initial value:	0	0	0	0	0	0	0	0
R/W:	R	R	R	R	R	R/W	R/W	R/W

TSYR is an 8-bit readable/writable register that selects independent operation or synchronous operation for the channel 0 to 2 TCNT counters. A channel performs synchronous operation when the corresponding bit in TSYR is set to 1.

TSYR is initialized to H'00 by a reset.

Bits 7 to 3—Reserved: These bits are always read as 0. The write value should always be 0.

Bits 2 to 0—Timer Synchro 2 to 0 (SYNC2 to SYNC0): These bits select whether operation is independent of or synchronized with other channels.

When synchronous operation is selected, synchronous presetting of multiple channels*¹, and synchronous clearing through counter clearing on another channel*² are possible.

Bit n: SYNCn	Description
0	TCNTn operates independently (Initial value) TCNT presetting/clearing is unrelated to other channels
1	TCNTn performs synchronous operation TCNT synchronous presetting/synchronous clearing is possible

Notes: n = 2 to 0

*¹ To set synchronous operation, the SYNC bits for two channels at least must be set to 1.

*² To set synchronous clearing, in addition to the SYNC bit, the TCNT clearing source must also be set by means of bits CCLR2 to CCLR0 in TCR.

17.3 Interface to Bus Master

17.3.1 16-Bit Registers

TCNT and TGR are 16-bit registers. As the data bus to the bus master is 16 bits wide, these registers can be read and written to in 16-bit units.

These registers cannot be read or written to in 8-bit units; 16-bit access must always be used.

An example of 16-bit register access operation is shown in figure 17.2.

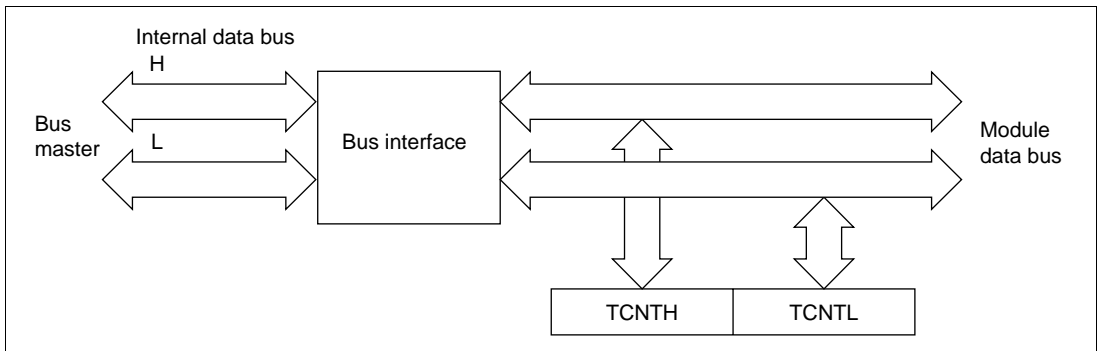

Figure 17.2 16-Bit Register Access Operation [Bus Master ↔ TCNT (16 Bits)]

17.3.2 8-Bit Registers

Registers other than TCNT and TGR are 8-bit. As the data bus to the CPU is 16 bits wide, these registers can be read and written to in 16-bit units. They can also be read and written to in 8-bit units.

Examples of 8-bit register access operation are shown in figures 17.3, 17.4, and 17.5.

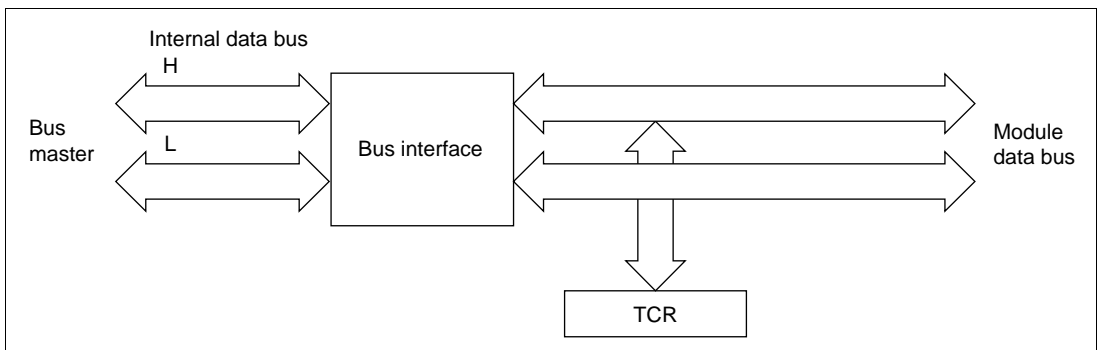

Figure 17.3 8-Bit Register Access Operation [Bus Master ↔ TCR (Upper 8 Bits)]

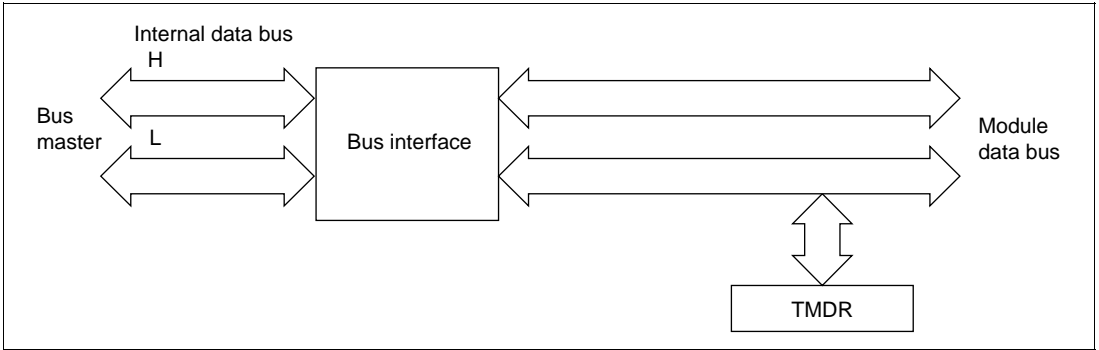

Figure 17.4 8-Bit Register Access Operation [Bus Master ↔ TMDR (Lower 8 Bits)]

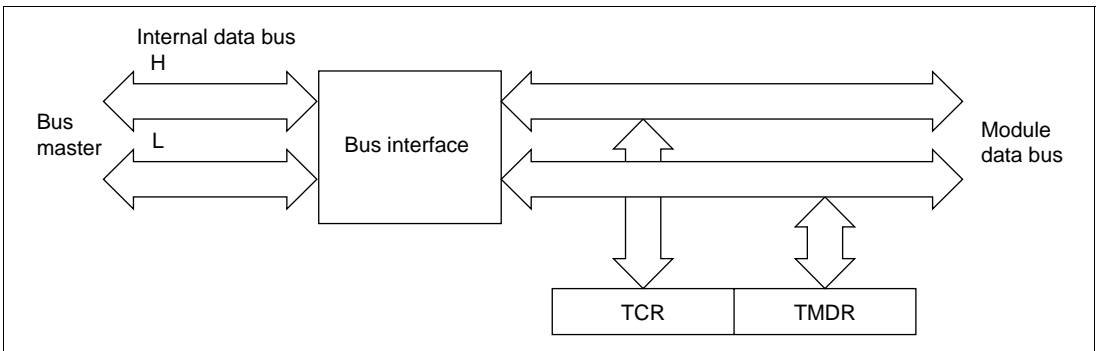

Figure 17.5 8-Bit Register Access Operation [Bus Master ↔ TCR and TMDR (16 Bits)]

17.4 Operation

17.4.1 Overview

Operation in each mode is outlined below.

Normal Operation: Each channel has a TCNT and TGR register. TCNT performs up-counting, and is also capable of free-running operation, synchronous counting, and external event counting.

Each TGR can be used as an input capture register or output compare register.

Synchronous Operation: The TCNT counter for a channel designated for synchronous operation by means of TSYR performs synchronous presetting. That is, when TCNT for a channel designated for synchronous operation is rewritten, the TCNT counters for the other channels are also rewritten at the same time. Synchronous clearing of the TCNT counters is also possible by setting the counter clear bits in TCR for channels designated for synchronous operation.

Buffer Operation

- When TGR is an output compare register
When a compare match occurs, the value in the buffer register for the relevant channel is transferred to TGR.
- When TGR is an input capture register
When input capture occurs, the value in TCNT is transfer to TGR and the value previously held in TGR is transferred to the buffer register.

PWM Mode: In this mode, a PWM waveform is output. The output level can be set by means of TIOR. A PWM waveform with a duty of between 0% and 100% can be output, according to the setting of each TGR register.

Phase Counting Mode: In this mode, TCNT is incremented or decremented by detecting the phases of two clocks input from the external clock input pins in channels 1, and 2. When phase counting mode is set, the corresponding TCLK pin functions as the clock input, and TCNT performs up- or down-counting.

This can be used for two-phase encoder pulse input.

17.4.2 Basic Functions

Counter Operation: When one of bits CST0 to CST2 is set to 1 in TSTR, the TCNT counter for the corresponding channel starts counting. TCNT can operate as a free-running counter, periodic counter, and so on.

- Example of count operation setting procedure

Figure 17.6 shows an example of the count operation setting procedure.

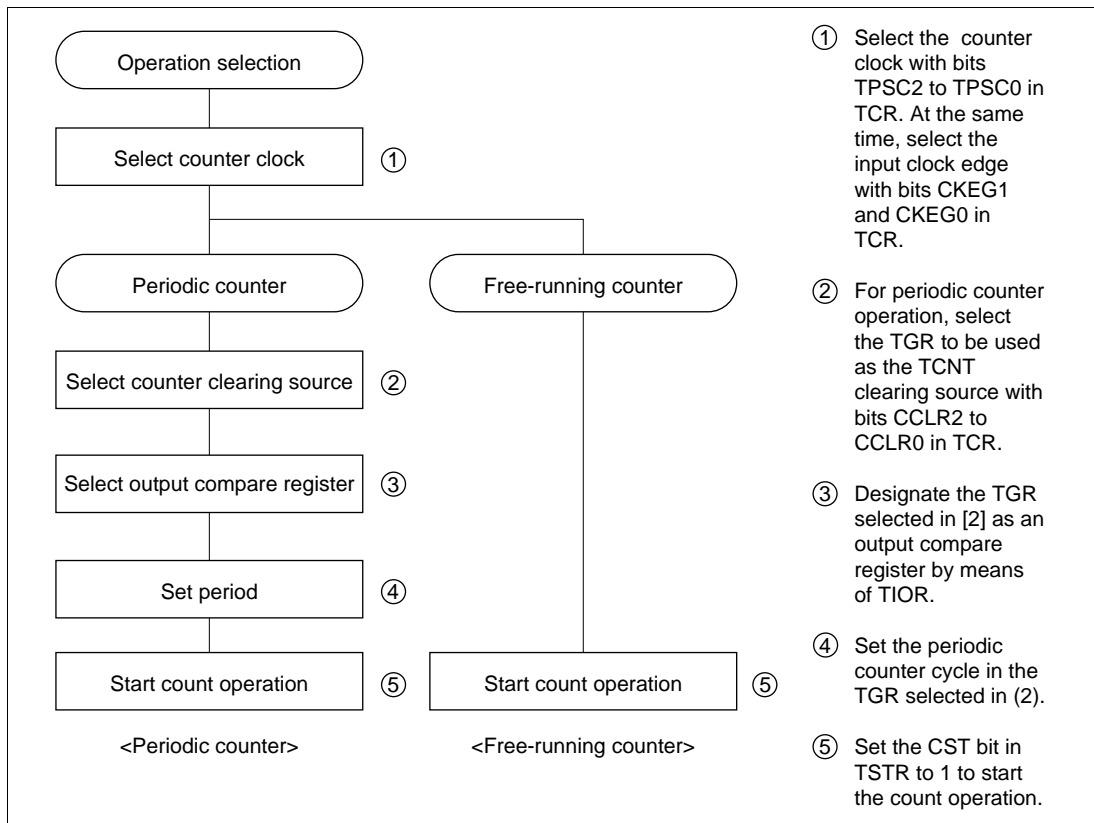

Figure 17.6 Example of Counter Operation Setting Procedure

- Free-running count operation and periodic count operation

Immediately after a reset, the TPU's TCNT counters are all designated as free-running counters. When the relevant bit in TSTR is set to 1 the corresponding TCNT counter starts up-count operation as a free-running counter. When TCNT overflows (from H'FFFF to H'0000), the TCFV bit in TSR is set to 1. If the value of the corresponding TCIEV bit in TIER is 1 at this point, the TPU requests an interrupt. After overflow, TCNT starts counting up again from H'0000.

Figure 17.7 illustrates free-running counter operation.

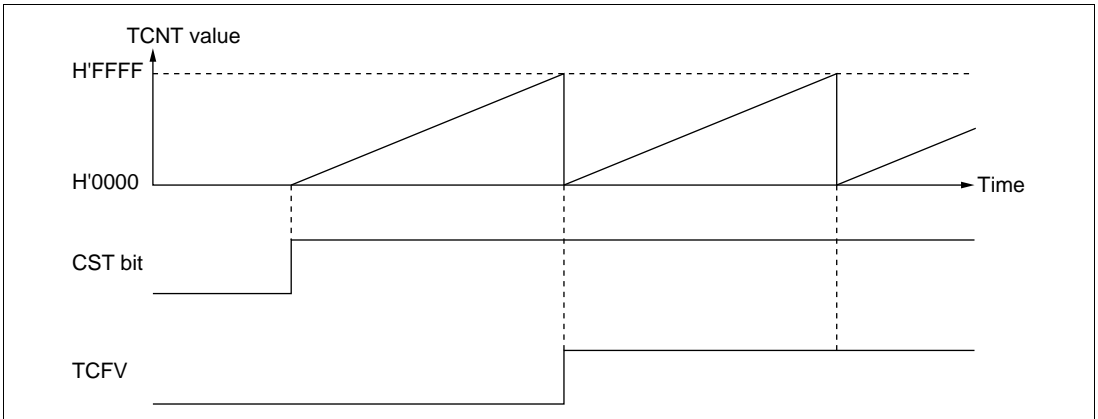

Figure 17.7 Free-Running Counter Operation

When compare match is selected as the TCNT clearing source, the TCNT counter for the relevant channel performs periodic count operation. The TGR register for setting the period is designated as an output compare register, and counter clearing by compare match is selected by means of bits CCLR2 to CCLR0 in TCR. After the settings have been made, TCNT starts up-count operation as periodic counter when the corresponding bit in TSTR is set to 1. When the count value matches the value in TGR, the TGF bit in TSR is set to 1 and TCNT is cleared to H'0000.

If the value of the corresponding TGIE bit in TIER is 1 at this point, the TPU requests an interrupt. After a compare match, TCNT starts counting up again from H'0000.

Figure 17.8 illustrates periodic counter operation.

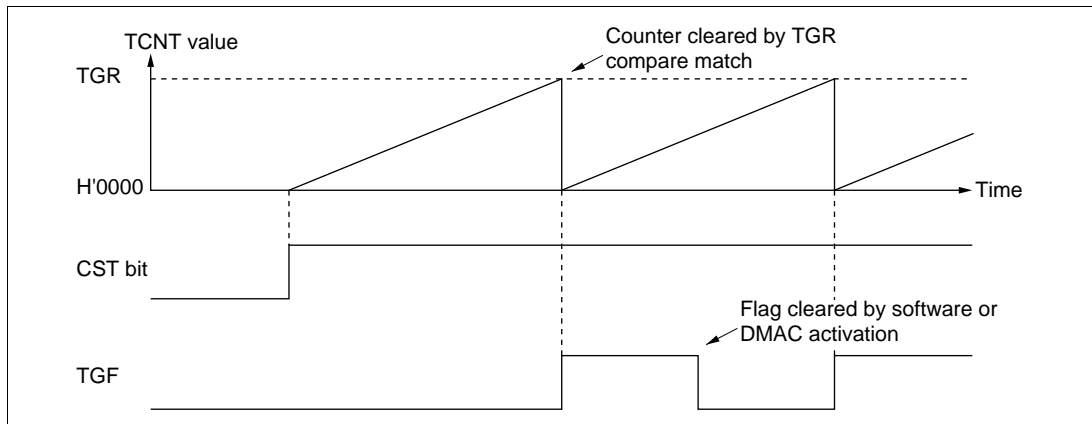

Figure 17.8 Periodic Counter Operation

Waveform Output by Compare Match: The TPU can perform 0, 1, or toggle output from the corresponding output pin using compare match.

- Example of setting procedure for waveform output by compare match

Figure 17.9 shows an example of the setting procedure for waveform output by compare match

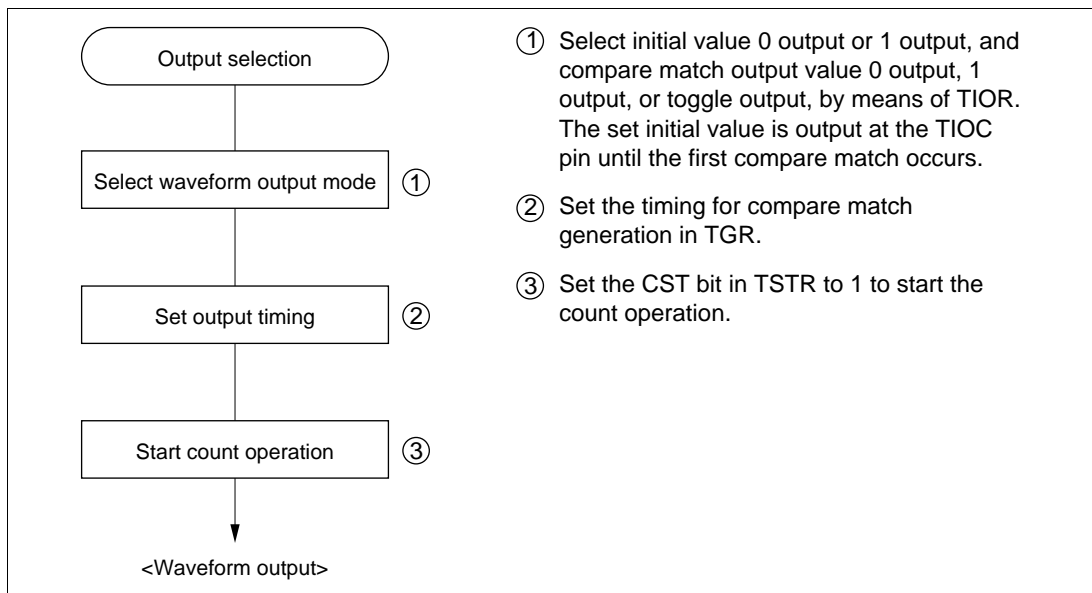

Figure 17.9 Example of Setting Procedure for Waveform Output by Compare Match

- Examples of waveform output operation

Figure 17.10 shows an example of 0 output/1 output.

In this example TCNT has been designated as a free-running counter, and settings have been made so that 1 is output by compare match A, and 0 is output by compare match B. When the set level and the pin level coincide, the pin level does not change.

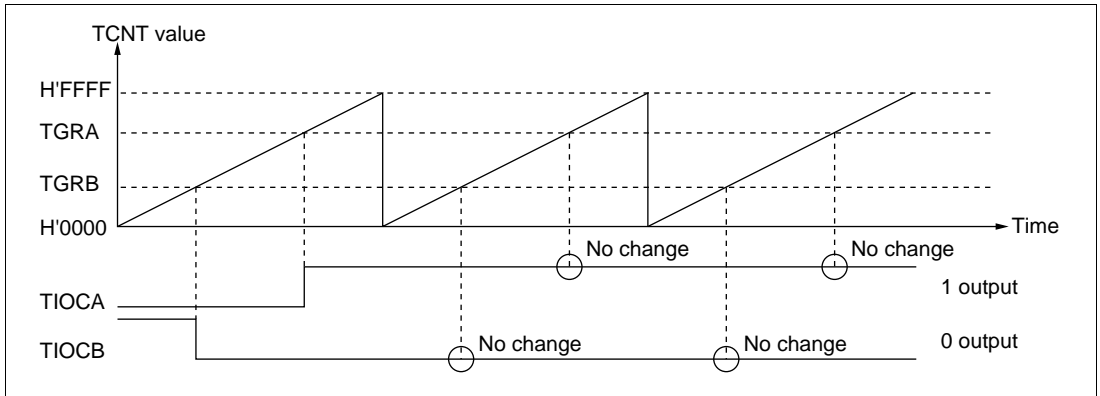

Figure 17.10 Example of 0 Output/1 Output Operation

Figure 17.11 shows an example of toggle output.

In this example TCNT has been designated as a periodic counter (with counter clearing performed by compare match B), and settings have been made so that output is toggled by both compare match A and compare match B.

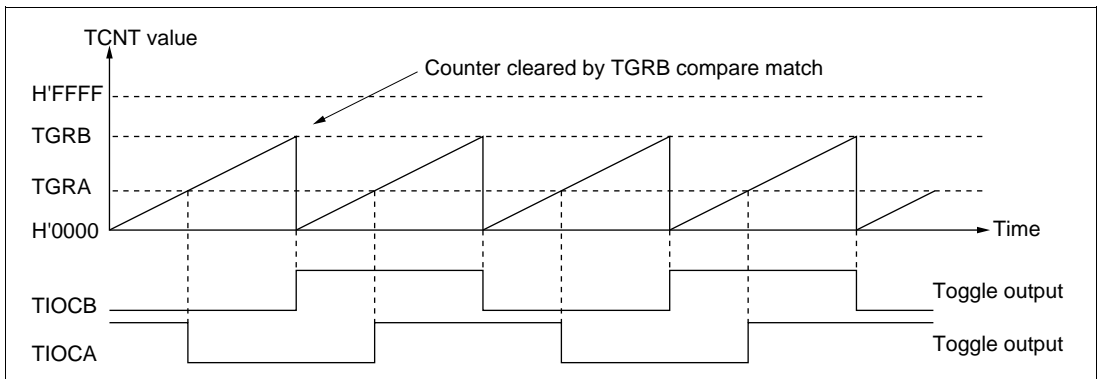

Figure 17.11 Example of Toggle Output Operation

Input Capture Function: The TCNT value can be transferred to TGR on detection of the TIOC pin input edge.

Rising edge, falling edge, or both edges can be selected as the detected edge.

- Example of input capture operation setting procedure

Figure 17.12 shows an example of the input capture operation setting procedure.

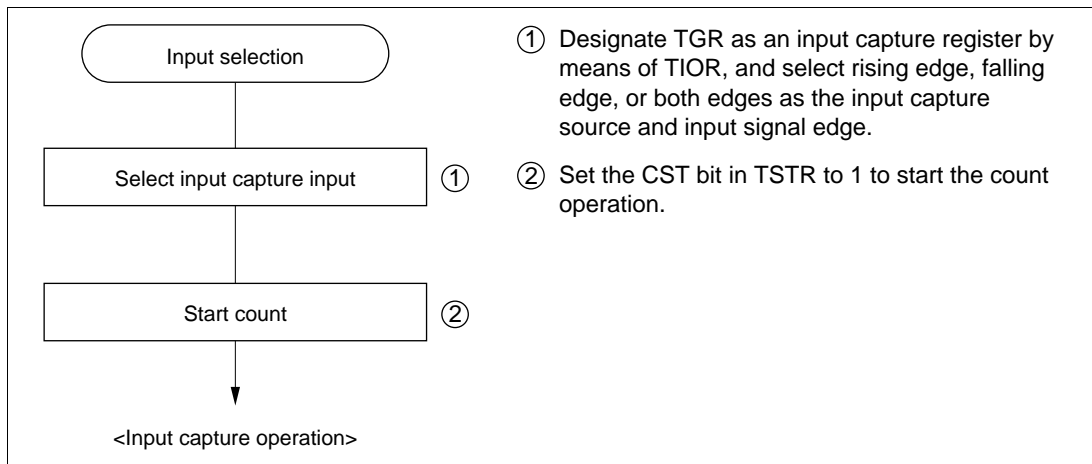

Figure 17.12 Example of Input Capture Operation Setting Procedure

- Example of input capture operation

Figure 17.13 shows an example of input capture operation.

In this example both rising and falling edges have been selected as the TIOCA pin input capture input edge, falling edge has been selected as the TIOCB pin input capture input edge, and counter clearing by TGRB input capture has been designated for TCNT.

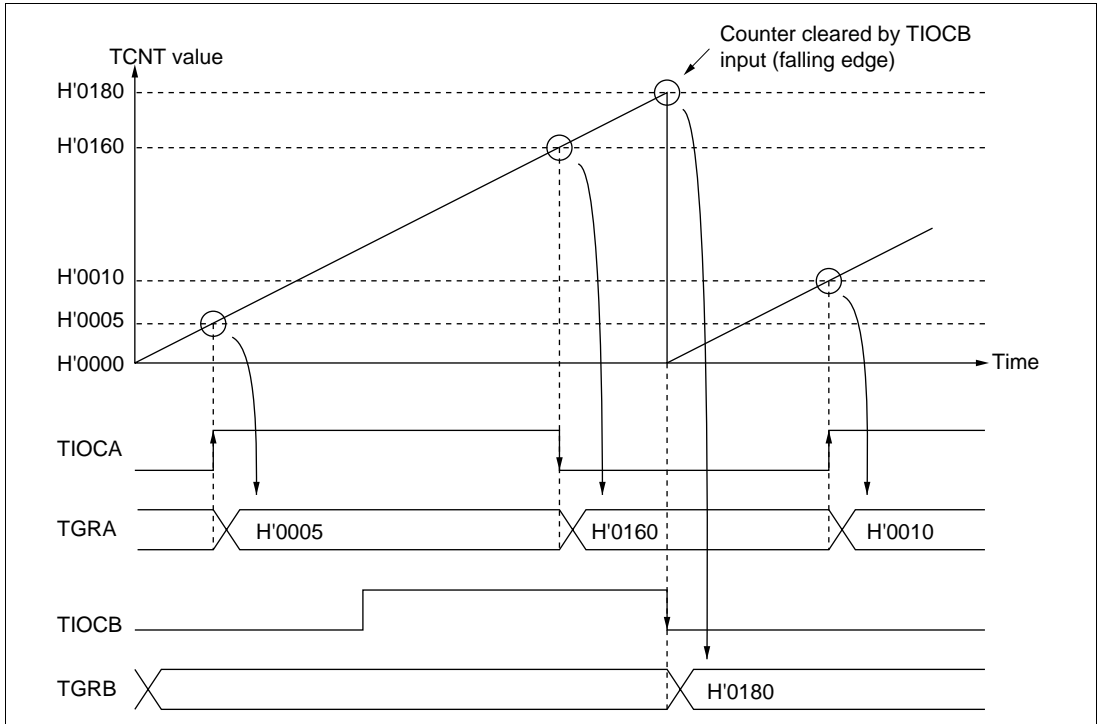

Figure 17.13 Example of Input Capture Operation

17.4.3 Synchronous Operation

In synchronous operation, the values in a number of TCNT counters can be rewritten simultaneously (synchronous presetting). Also, a number of TCNT counters can be cleared simultaneously by making the appropriate setting in TCR (synchronous clearing).

Synchronous operation enables TGR to be incremented with respect to a single time base.

Channels 0 to 2 can all be designated for synchronous operation.

Example of Synchronous Operation Setting Procedure: Figure 17.14 shows an example of the synchronous operation setting procedure.

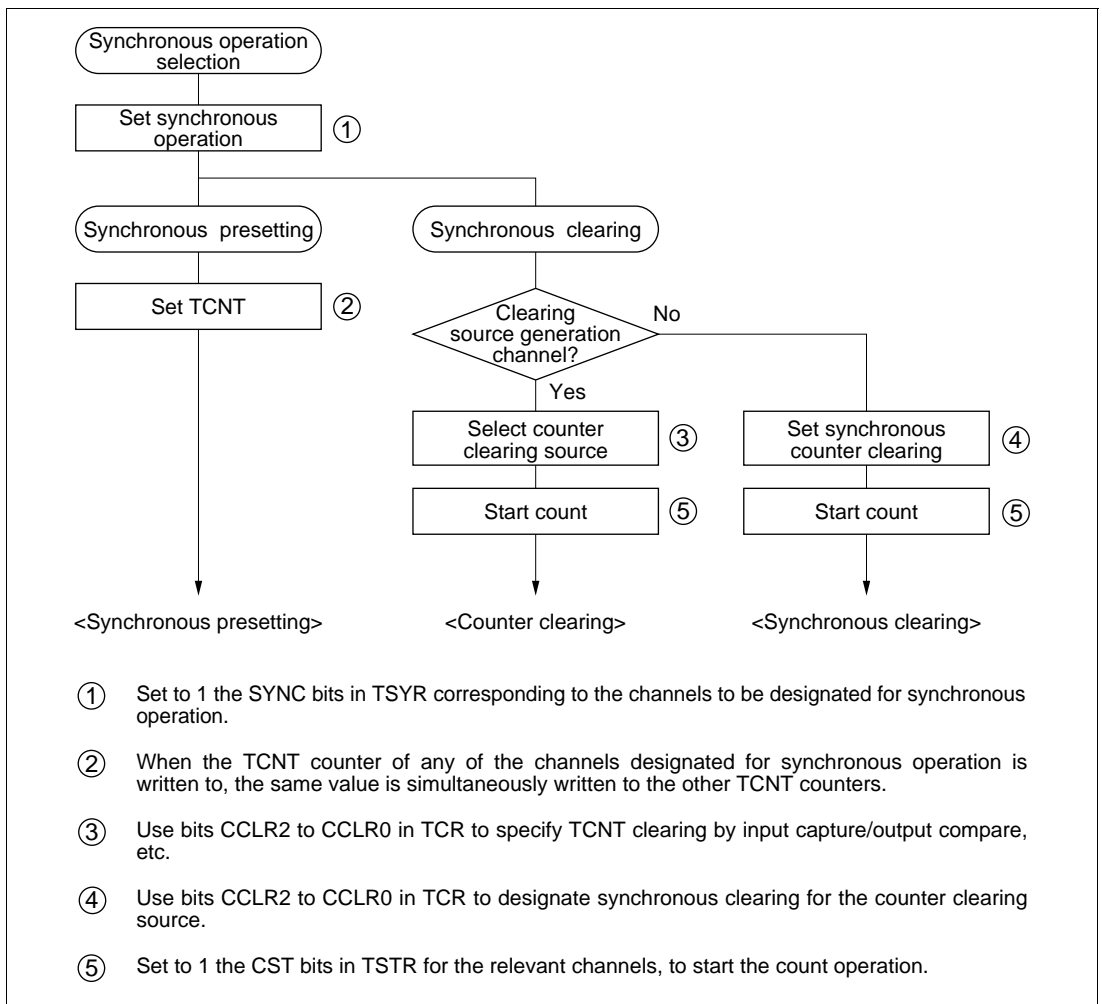

Figure 17.14 Example of Synchronous Operation Setting Procedure

Example of Synchronous Operation: Figure 17.15 shows an example of synchronous operation.

In this example, synchronous operation and PWM mode 1 have been designated for channels 0 to 2, TGR0B compare match has been set as the channel 0 counter clearing source, and synchronous clearing has been set for the channel 1 and 2 counter clearing source.

Three-phase PWM waveforms are output from pins TIOC0A, TIOC1A, and TIOC2A. At this time, synchronous presetting, and synchronous clearing by TGR0B compare match, is performed for channel 0 to 2 TCNT counters, and the data set in TGR0B is used as the PWM cycle.

For details of PWM modes, see section 17.4.5, PWM Modes.

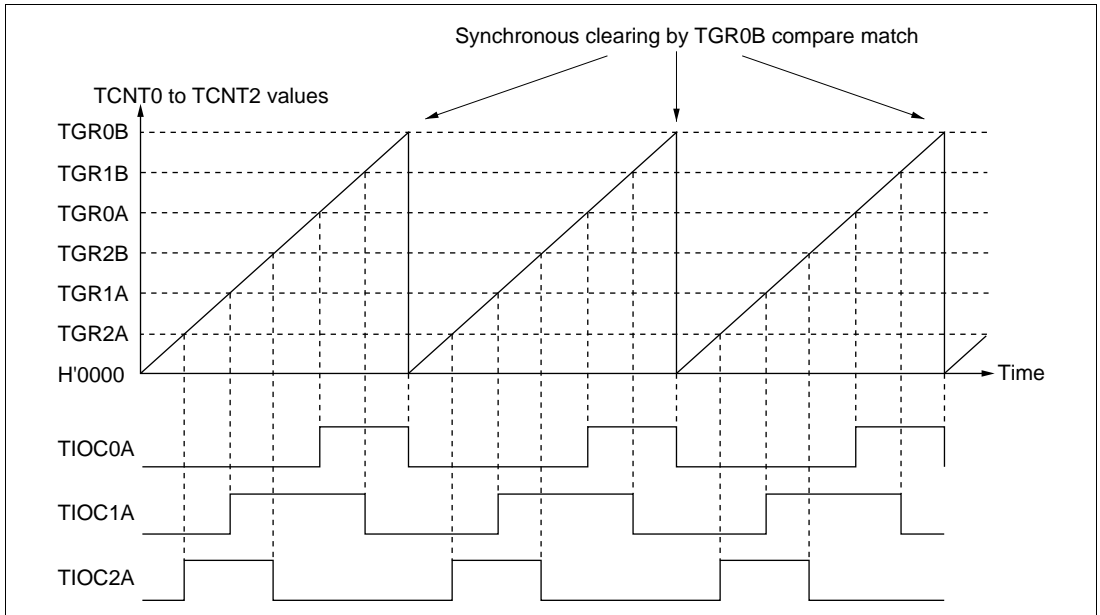

Figure 17.15 Example of Synchronous Operation

17.4.4 Buffer Operation

Buffer operation, provided for channel 0 enables TGRC and TGRD to be used as buffer registers.

Buffer operation differs depending on whether TGR has been designated as an input capture register or as a compare match register.

Table 17.5 shows the register combinations used in buffer operation.

Table 17.5 Register Combinations in Buffer Operation

Channel	Timer General Register	Buffer Register
0	TGR0A	TGR0C
	TGR0B	TGR0D

- When TGR is an output compare register

When a compare match occurs, the value in the buffer register for the corresponding channel is transferred to the timer general register.

This operation is illustrated in figure 17.16.

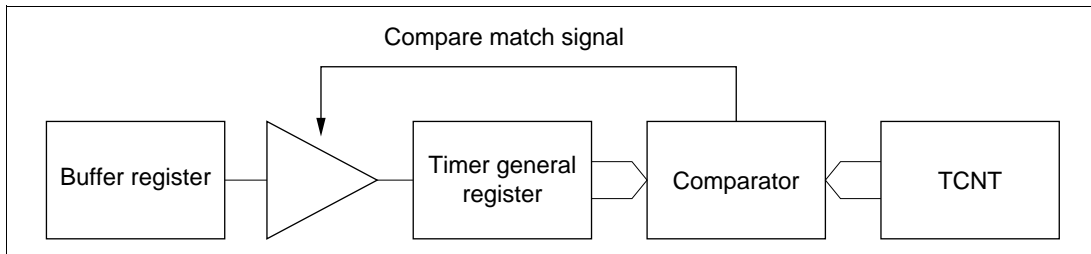

Figure 17.16 Compare Match Buffer Operation

- When TGR is an input capture register

When input capture occurs, the value in TCNT is transferred to TGR and the value previously held in the timer general register is transferred to the buffer register.

This operation is illustrated in figure 17.17.

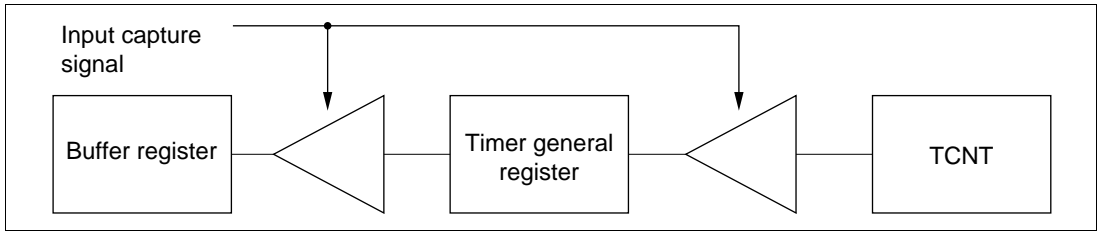

Figure 17.17 Input Capture Buffer Operation

Example of Buffer Operation Setting Procedure: Figure 17.18 shows an example of the buffer operation setting procedure.

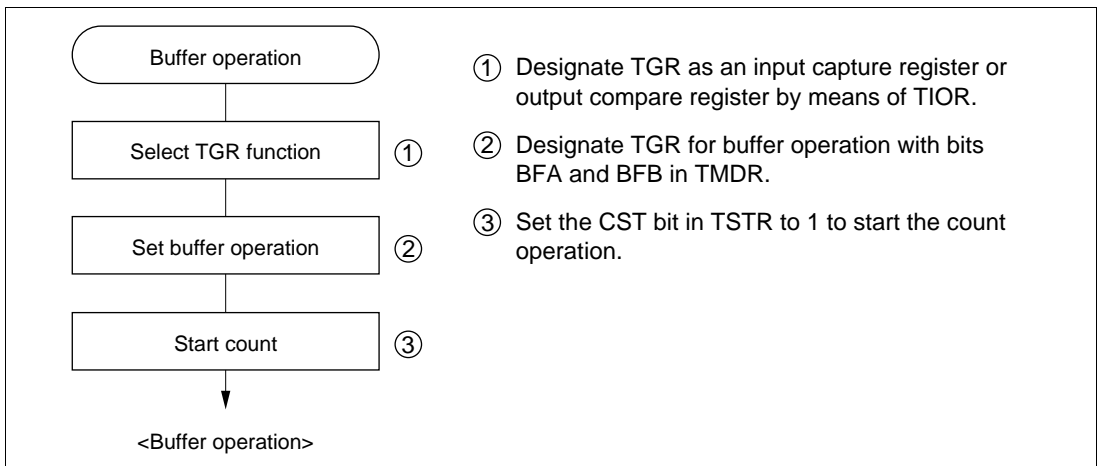

Figure 17.18 Example of Buffer Operation Setting Procedure

Examples of Buffer Operation

- When TGR is an output compare register

Figure 17.19 shows an operation example in which PWM mode 1 has been designated for channel 0, and buffer operation has been designated for TGRA and TGRC. The settings used in this example are TCNT clearing by compare match B, 1 output at compare match A, and 0 output at compare match B.

As buffer operation has been set, when compare match A occurs the output changes and the value in buffer register TGRC is simultaneously transferred to timer general register TGRA. This operation is repeated each time compare match A occurs.

For details of PWM modes, see section 17.4.5, PWM Modes.

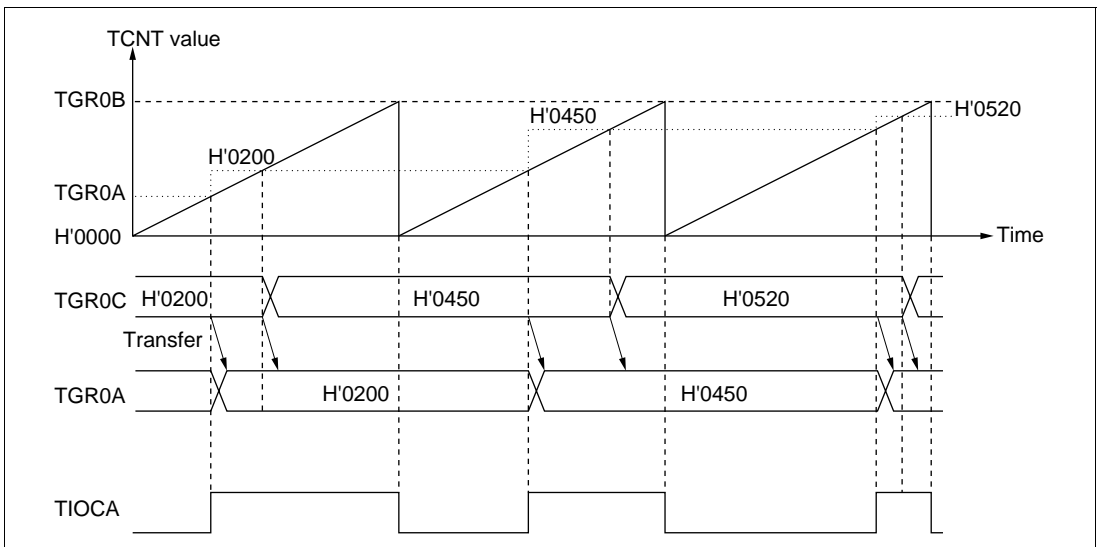

Figure 17.19 Example of Buffer Operation (1)

- When TGR is an input capture register

Figure 17.20 shows an operation example in which TGRA has been designated as an input capture register, and buffer operation has been designated for TGRA and TGRC.

Counter clearing by TGRA input capture has been set for TCNT, and both rising and falling edges have been selected as the TIOCA pin input capture input edge.

As buffer operation has been set, when the TCNT value is stored in TGRA upon occurrence of input capture A, the value previously stored in TGRA is simultaneously transferred to TGRC.

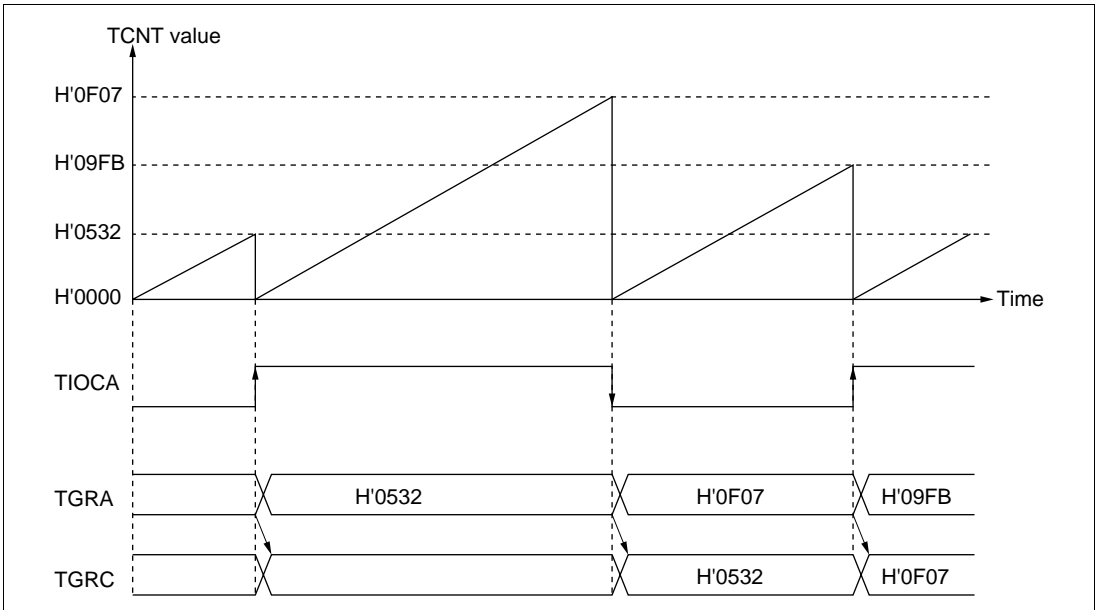

Figure 17.20 Example of Buffer Operation (2)

17.4.5 PWM Modes

In PWM mode, PWM waveforms are output from the output pins. 0, 1, or toggle output can be selected as the output level in response to compare match of each TGR.

Designating TGR compare match as the counter clearing source enables the period to be set in that register. All channels can be designated for PWM mode independently. Synchronous operation is also possible.

There are two PWM modes, as described below.

- PWM mode 1

PWM output is generated by pairing TGRA with TGRB and TGRC with TGRD. The output specified by bits IOA3–IOA0 and IOC3–IOC0 in TIOR is performed in response to compare match A and C, and the output specified by bits IOB3–IOB0 and IOD3–IOD0 in TIOR in response to compare match B and D, from pins TIOCA and TIOCC. The initial output value is the value set in TGRA or TGRC. If the set values of paired TGRs are identical, the output value does not change when a compare match occurs.

In PWM mode 1, a maximum 4-phase PWM output is possible.

- PWM mode 2

PWM output is generated using one TGR as the cycle register and the others as duty registers. The output specified by TIOR is performed in response to a compare match. Also, when the counter is cleared by a synchronization register compare match, pin output values are the initial values set in TIOR. If the set values of the period and duty registers are identical, the output value does not change when a compare match occurs.

In PWM mode 2, a maximum 7-phase PWM output is possible by combined use with synchronous operation.

The correspondence between PWM output pins and registers is shown in table 17.6.

Table 17.6 PWM Output Registers and Output Pins

Channel	Registers	Output Pins	
		PWM Mode 1	PWM Mode 2
0	TGR0A	TIOCA0	TIOCA0
	TGR0B		TIOCB0
	TGR0C	TIOCC0	TIOCC0
	TGR0D		TIOCD0
1	TGR1A	TIOCA1	TIOCA1
	TGR1B		TIOCB1
2	TGR2A	TIOCA2	TIOCA2
	TGR2B		TIOCB2

Note: In PWM mode 2, PWM output is not possible for the TGR register in which the period is set.

Example of PWM Mode Setting Procedure: Figure 17.21 shows an example of the PWM mode setting procedure.

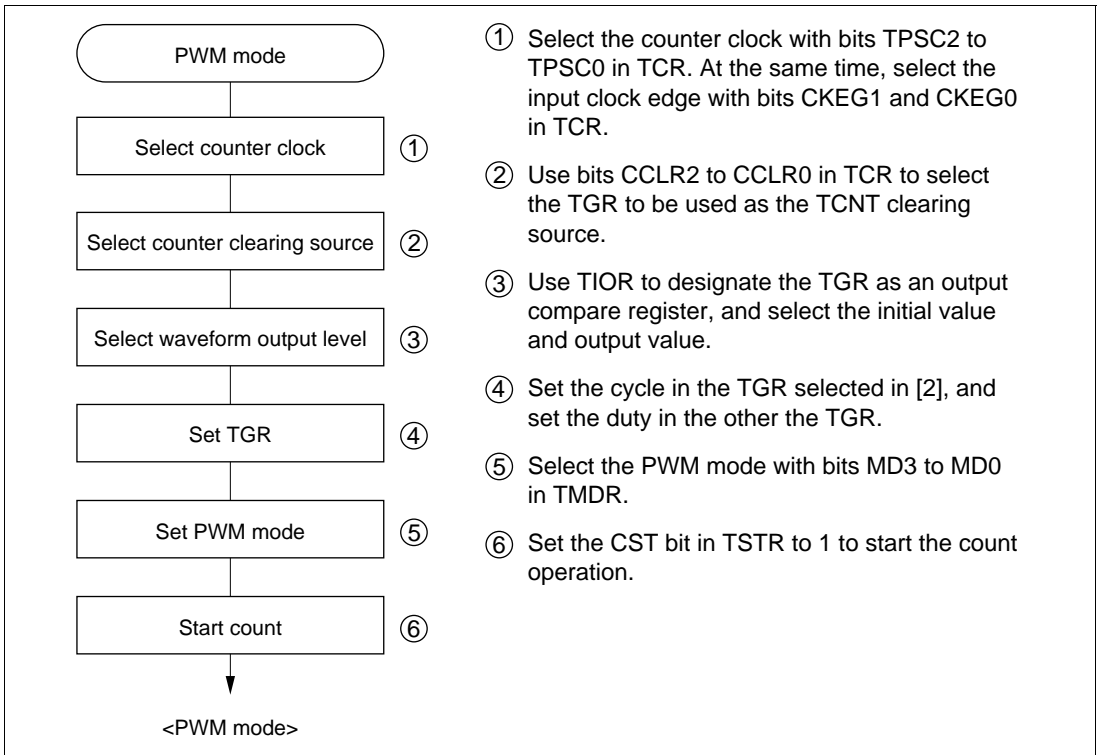

Figure 17.21 Example of PWM Mode Setting Procedure

Examples of PWM Mode Operation: Figure 17.22 shows an example of PWM mode 1 operation.

In this example, TGRA compare match is set as the TCNT clearing source, 0 is set for the TGRA initial output value and output value, and 1 output is set as the TGRB output value.

In this case, the value set in TGRA is used as the period, and the values set in TGRB registers as the duty.

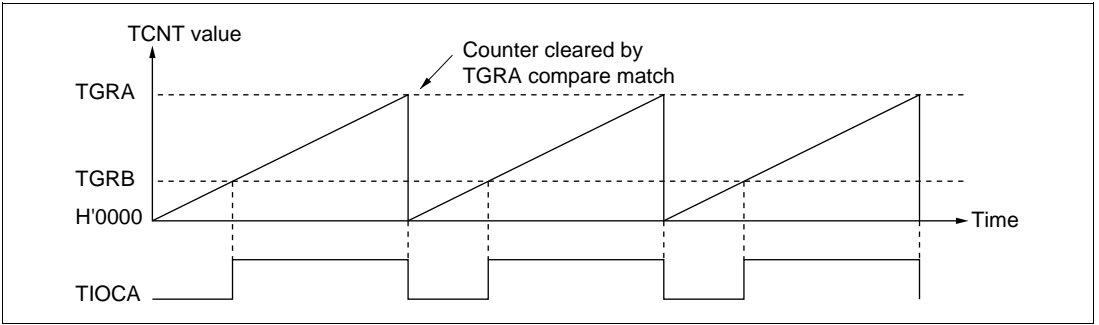

Figure 17.22 Example of PWM Mode Operation (1)

Figure 17.23 shows an example of PWM mode 2 operation.

In this example, synchronous operation is designated for channels 0 and 1, TGR1B compare match is set as the TCNT clearing source, and 0 is set for the initial output value and 1 for the output value of the other TGR registers, to output a 5-phase PWM waveform.

In this case, the value set in TGR1B is used as the cycle, and the values set in the other TGRs as the duty.

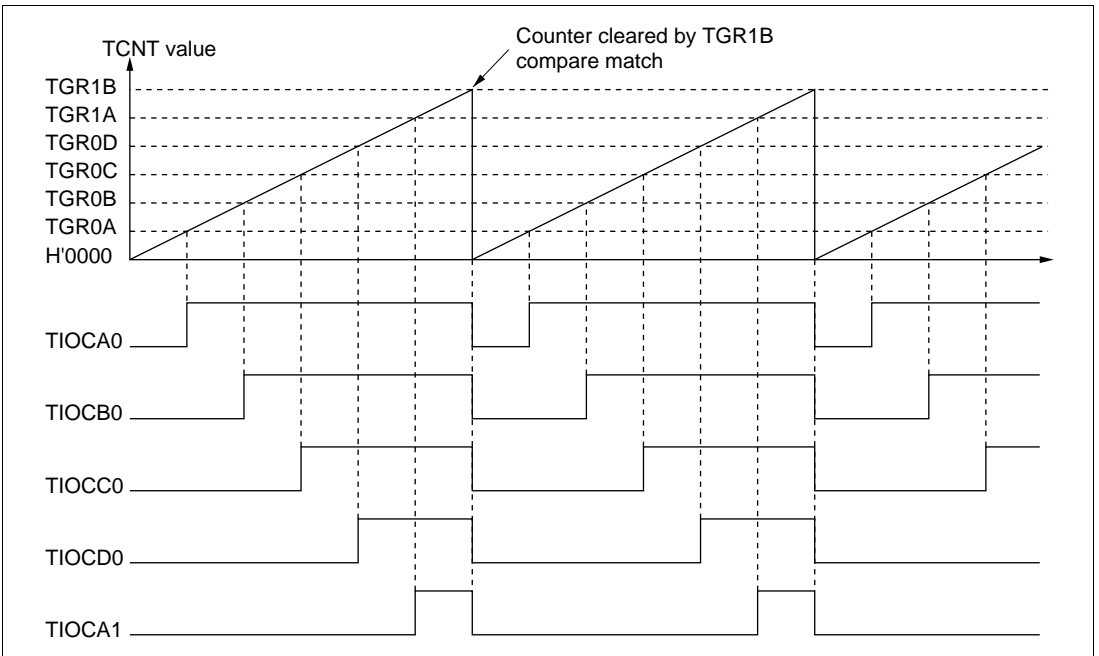

Figure 17.23 Example of PWM Mode Operation (2)

Figure 17.24 shows examples of PWM waveform output with 0% duty and 100% duty in PWM mode.

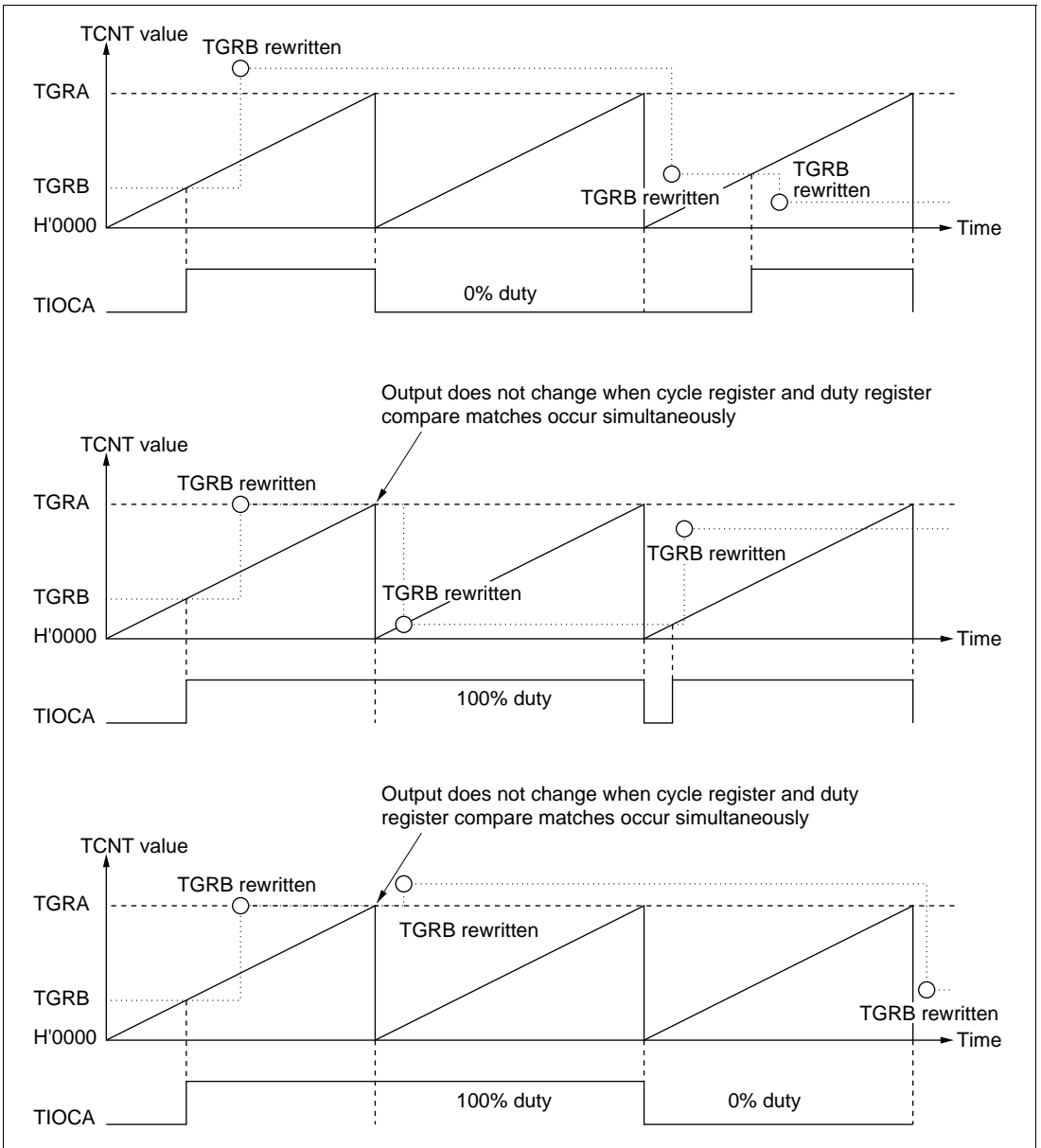

Figure 17.24 Example of PWM Mode Operation (3)

17.4.6 Phase Counting Mode

In phase counting mode, the phase difference between two external clock inputs is detected and TCNT is incremented/decremented accordingly. This mode can be set for channels 1, and 2.

When phase counting mode is set, an external clock is selected as the counter input clock and TCNT operates as an up/down-counter regardless of the setting of bits TPSC2 to TPSC0 and bits CKEG1 and CKEG0 in TCR. However, the functions of bits CCLR1 and CCLR0 in TCR, and of TIOR, TIER, and TGR are valid, and input capture/compare match and interrupt functions can be used.

When overflow occurs while TCNT is counting up, the TCFV flag in TSR is set; when underflow occurs while TCNT is counting down, the TCFU flag is set.

The TCFD bit in TSR is the count direction flag. Reading the TCFD flag provides an indication of whether TCNT is counting up or down.

Table 17.7 shows the correspondence between external clock pins and channels.

Table 17.7 Phase Counting Mode Clock Input Pins

Channels	External Clock Pins	
	A-Phase	B-Phase
When channel 1 is set to phase counting mode	TCLKA	TCLKB
When channel 2 is set to phase counting mode	TCLKC	TCLKD

Example of Phase Counting Mode Setting Procedure: Figure 17.25 shows an example of the phase counting mode setting procedure.

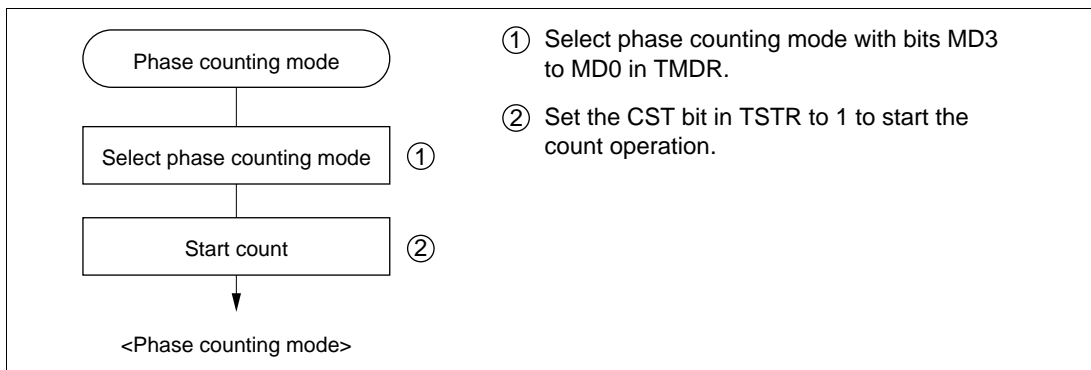

Figure 17.25 Example of Phase Counting Mode Setting Procedure

Examples of Phase Counting Mode Operation: In phase counting mode, TCNT counts up or down according to the phase difference between two external clocks. There are four modes, according to the count conditions.

- Phase counting mode 1

Figure 17.26 shows an example of phase counting mode 1 operation, and table 17.8 summarizes the TCNT up/down-count conditions.

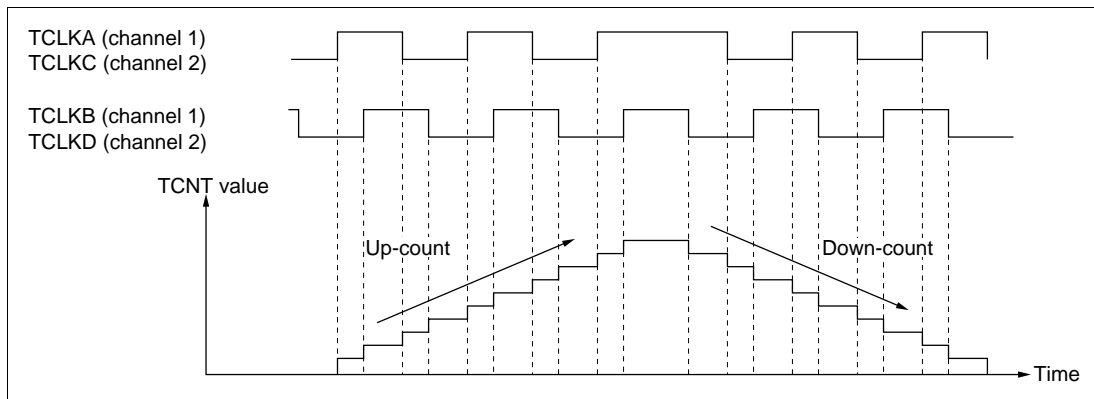

Figure 17.26 Example of Phase Counting Mode 1 Operation

Table 17.8 Up/Down-Count Conditions in Phase Counting Mode 1

TCLKA (Channel 1) TCLKC (Channel 2)	TCLKB (Channel 1) TCLKD (Channel 2)	Operation
High level	\uparrow	Up-count
Low level	\downarrow	
\uparrow	Low level	
\downarrow	High level	
High level	\downarrow	Down-count
Low level	\uparrow	
\uparrow	High level	
\downarrow	Low level	

Notes: \uparrow : Rising edge
 \downarrow : Falling edge

- Phase counting mode 2

Figure 17.27 shows an example of phase counting mode 2 operation, and table 17.9 summarizes the TCNT up/down-count conditions.

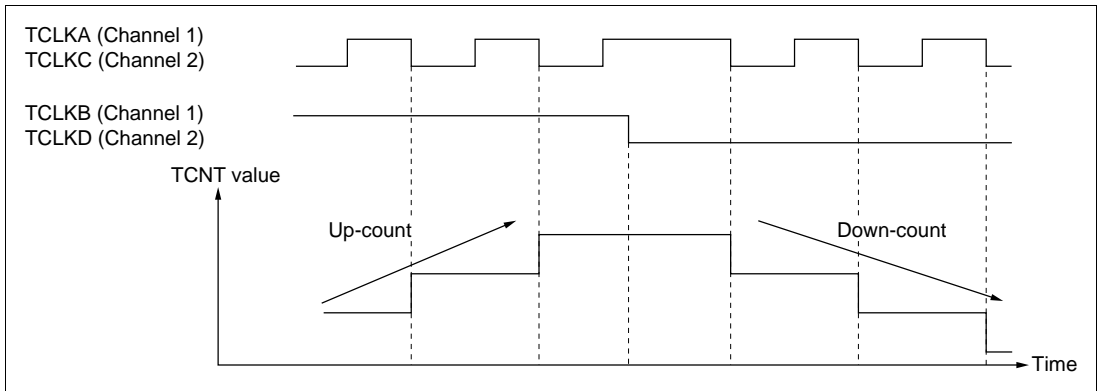

Figure 17.27 Example of Phase Counting Mode 2 Operation

Table 17.9 Up/Down-Count Conditions in Phase Counting Mode 2

TCLKA (Channel 1) TCLKC (Channel 2)	TCLKB (Channel 1) TCLKD (Channel 2)	Operation
High level		Don't care
Low level		Don't care
	Low level	Don't care
	High level	Up-count
High level		Don't care
Low level		Don't care
	High level	Don't care
	Low level	Down-count

Notes: : Rising edge

: Falling edge

- Phase counting mode 3

Figure 17.28 shows an example of phase counting mode 3 operation, and table 17.10 summarizes the TCNT up/down-count conditions.

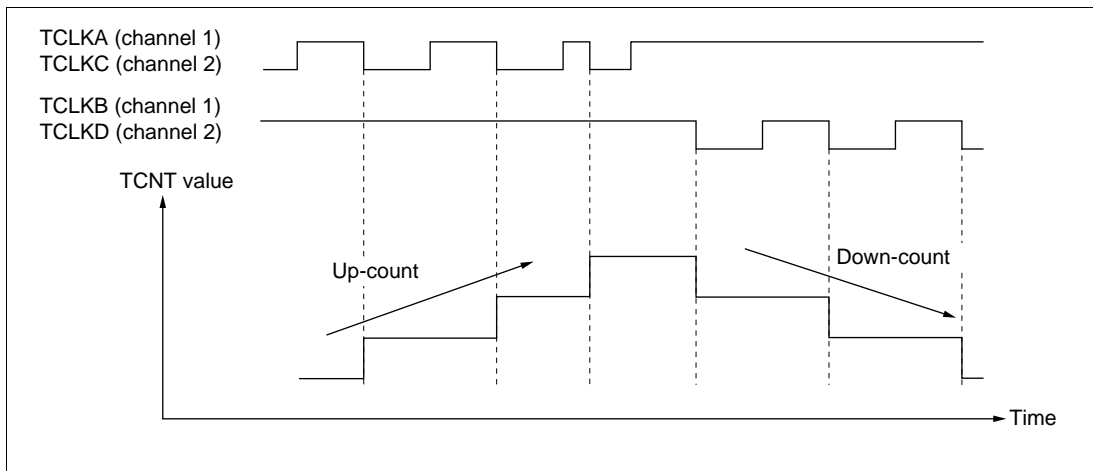

Figure 17.28 Example of Phase Counting Mode 3 Operation

Table 17.10 Up/Down-Count Conditions in Phase Counting Mode 3

TCLKA (Channel 1) TCLKC (Channel 2)	TCLKB (Channel 1) TCLKD (Channel 2)	Operation
High level		Don't care
Low level		Don't care
	Low level	Don't care
	High level	Up-count
High level		Down-count
Low level		Don't care
	High level	Don't care
	Low level	Don't care

Notes: : Rising edge

: Falling edge

- Phase counting mode 4

Figure 17.29 shows an example of phase counting mode 4 operation, and table 17.11 summarizes the TCNT up/down-count conditions.

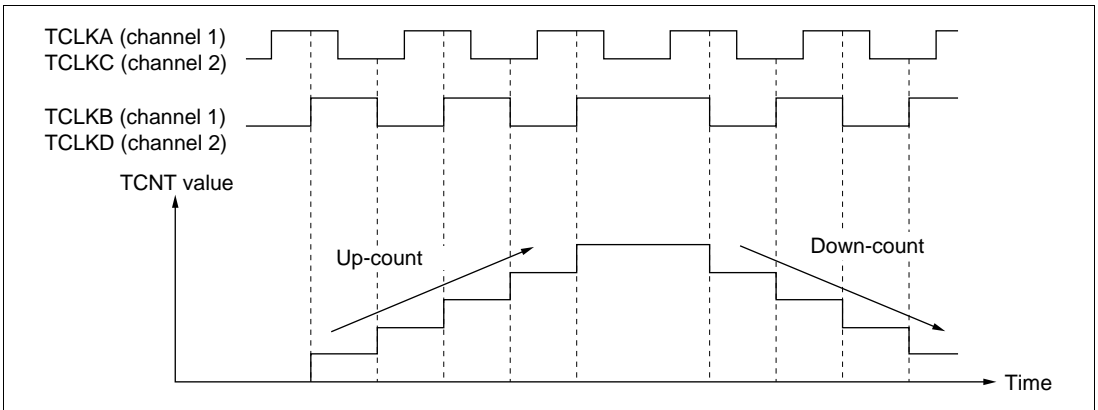

Figure 17.29 Example of Phase Counting Mode 4 Operation

Table 17.11 Up/Down-Count Conditions in Phase Counting Mode 4

TCLKA (Channel 1) TCLKC (Channel 2)	TCLKB (Channel 1) TCLKD (Channel 2)	Operation
High level		Up-count
Low level		Up-count
	Low level	Don't care
	High level	Don't care
High level		Down-count
Low level		Down-count
	High level	Don't care
	Low level	Don't care

Notes: : Rising edge
 : Falling edge

17.5 Interrupts

17.5.1 Interrupt Sources and Priorities

There are three kinds of TPU interrupt source: TGR input capture/compare match, TCNT overflow, and TCNT underflow. Each interrupt source has its own status flag and enable/disable bit, allowing generation of interrupt request signals to be enabled or disabled individually.

When an interrupt request is generated, the corresponding status flag in TSR is set to 1. If the corresponding enable/disable bit in TIER is set to 1 at this time, an interrupt is requested. The interrupt request is cleared by clearing the status flag to 0.

Relative channel priorities can be changed by the interrupt controller, but the priority order within a channel is fixed. For details, see section 5, Interrupt Controller (INTC).

Table 17.12 lists the TPU interrupt sources.

Table 17.12 TPU Interrupts

Channel	Interrupt Source	Description	DMAC Activation	Priority
0	TGI0A	TGR0A input capture/compare match	Possible	High
	TGI0B	TGR0B input capture/compare match	Possible	↑
	TGI0C	TGR0C input capture/compare match	Possible	
	TGI0D	TGR0D input capture/compare match	Possible	
	TCI0V	TCNT0 overflow	Not possible	
1	TGI1A	TGR1A input capture/compare match	Not possible	
	TGI1B	TGR1B input capture/compare match	Not possible	
	TCI1V	TCNT1 overflow	Not possible	
	TCI1U	TCNT1 underflow	Not possible	
2	TGI2A	TGR2A input capture/compare match	Not possible	
	TGI2B	TGR2B input capture/compare match	Not possible	
	TCI2V	TCNT2 overflow	Not possible	↓
	TCI2U	TCNT2 underflow	Not possible	Low

Note: This table shows the initial state immediately after a reset. The relative channel priorities can be changed by the interrupt controller.

Input Capture/Compare Match Interrupt: An interrupt is requested if the TGIE bit in TIER is set to 1 when the TGF flag in TSR is set to 1 by the occurrence of a TGR input capture/compare match on a particular channel. The interrupt request is cleared by clearing the TGF flag to 0. The TPU has 8 input capture/compare match interrupts, four for channel 0, and two each for channels 1, and 2.

Overflow Interrupt: An interrupt is requested if the TCIEV bit in TIER is set to 1 when the TCFV flag in TSR is set to 1 by the occurrence of TCNT overflow on a particular channel. The interrupt request is cleared by clearing the TCFV flag to 0. The TPU has three overflow interrupts, one for each channel.

Underflow Interrupt: An interrupt is requested if the TCIEU bit in TIER is set to 1 when the TCFU flag in TSR is set to 1 by the occurrence of TCNT underflow on channel. The interrupt request is cleared by clearing the TCFU flag to 0. The TPU has two underflow interrupts, one each for channels 1 and 2.

17.5.2 DMAC Activation

The DMAC can be activated by the TGR input capture/compare match interrupt for a channel. For details, see section 11, Direct Memory Access Controller (DMAC).

A total of four TPU input capture/compare match interrupts can be used as DMAC activation sources for channel 0.

17.6 Operation Timing

17.6.1 Input/Output Timing

TCNT Count Timing: Figure 17.30 shows TCNT count timing in internal clock operation, and figure 17.31 shows TCNT count timing in external clock operation.

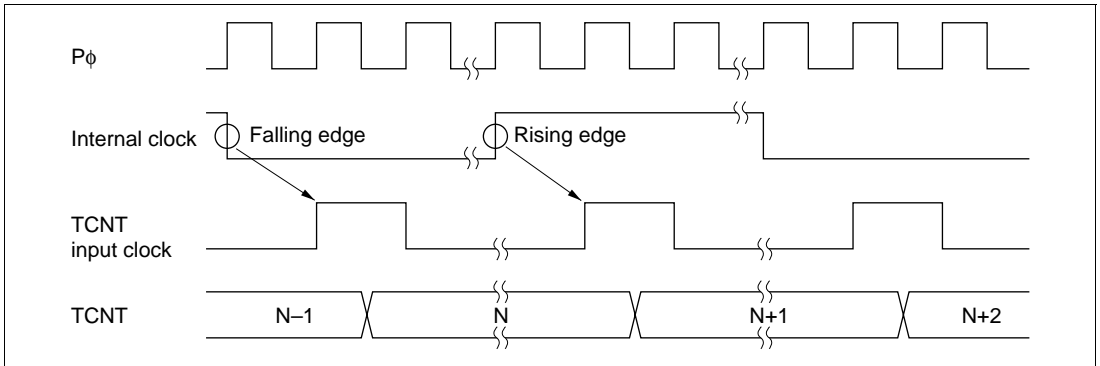

Figure 17.30 Count Timing in Internal Clock Operation

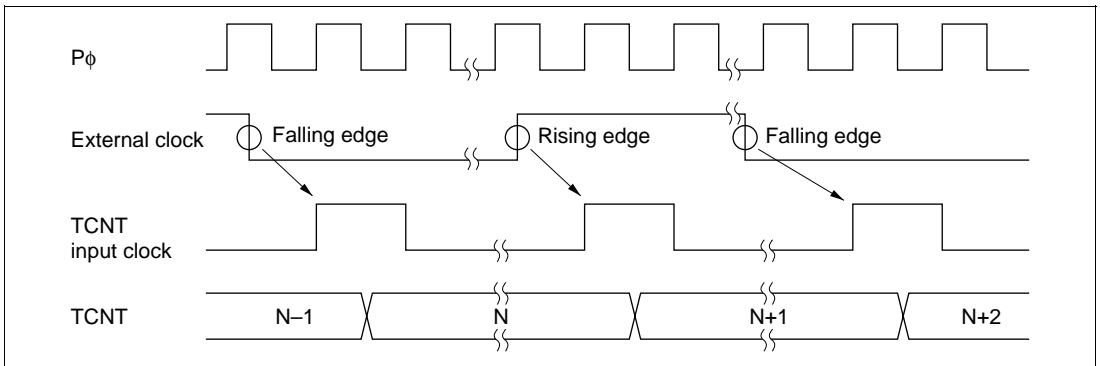

Figure 17.31 Count Timing in External Clock Operation

Output Compare Output Timing: A compare match signal is generated in the final state in which TCNT and TGR match (the point at which the count value matched by TCNT is updated). When a compare match signal is generated, the output value set in TIOR is output at the output compare output pin (TIOC pin). After a match between TCNT and TGR, the compare match signal is not generated until the TCNT input clock is generated.

Figure 17.32 shows output compare output timing.

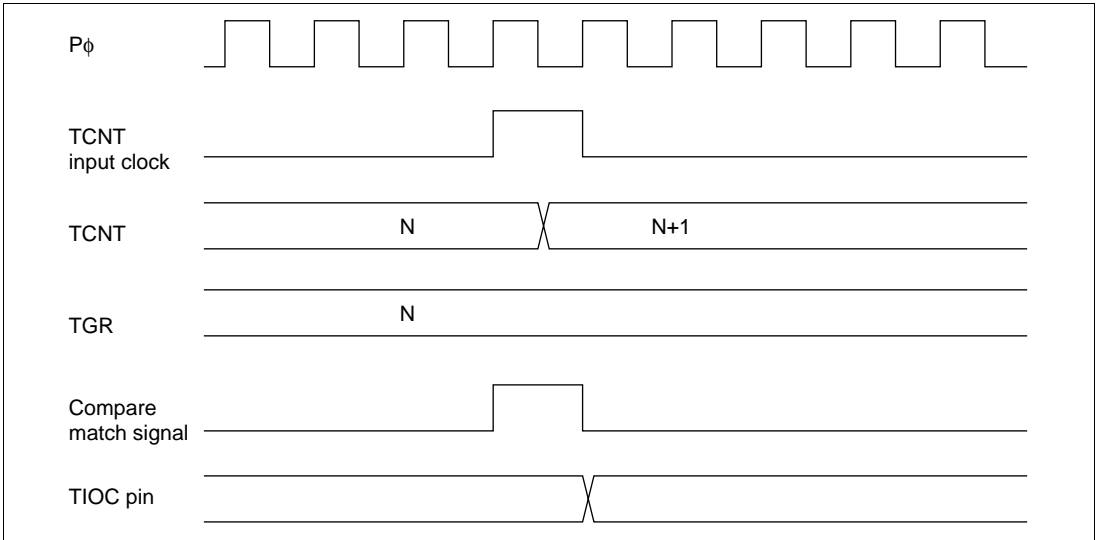

Figure 17.32 Output Compare Output Timing

Input Capture Signal Timing: Figure 17.33 shows input capture signal timing.

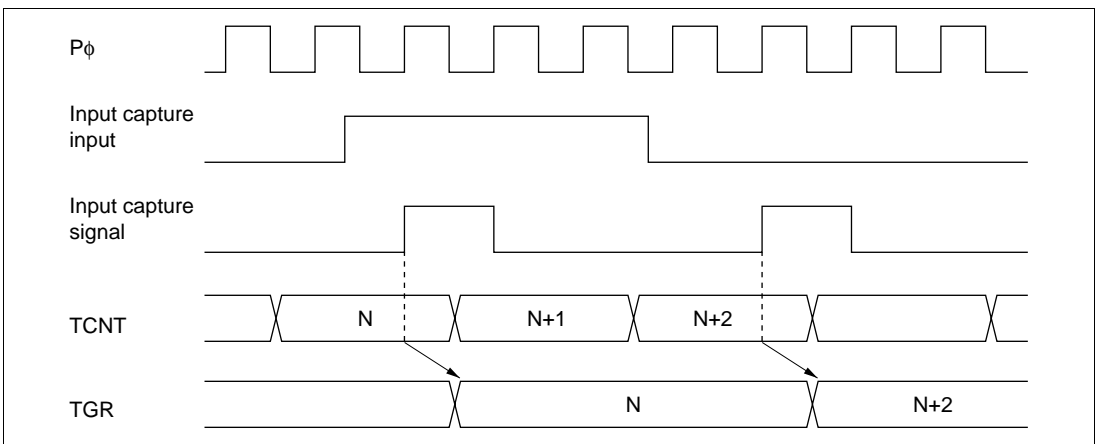

Figure 17.33 Input Capture Input Signal Timing

Timing for Counter Clearing by Compare Match/Input Capture: Figure 17.34 shows the timing when counter clearing by compare match occurrence is specified, and figure 17.35 shows the timing when counter clearing by input capture occurrence is specified.

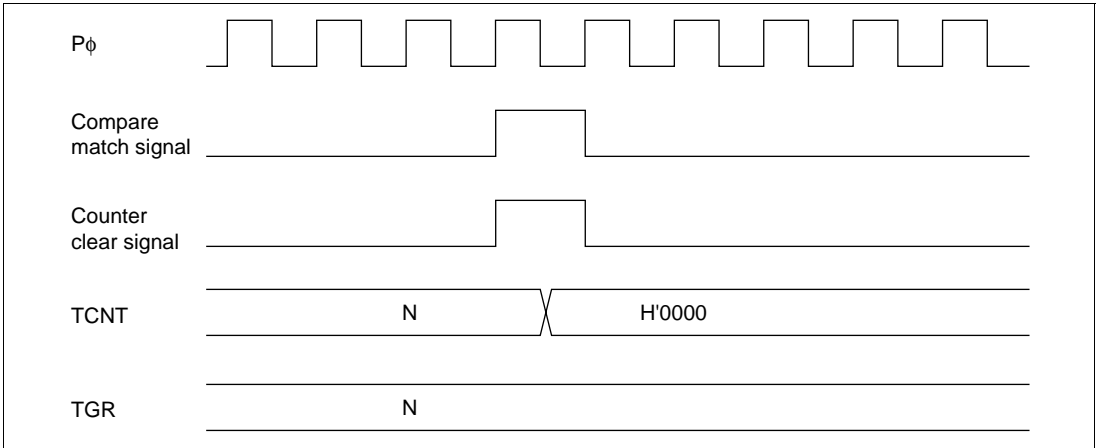

Figure 17.34 Counter Clear Timing (Compare Match)

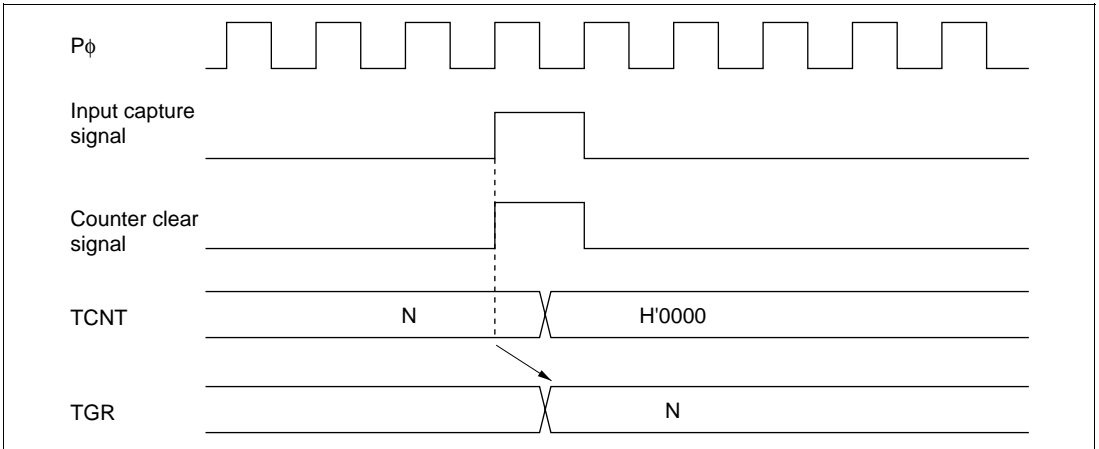

Figure 17.35 Counter Clear Timing (Input Capture)

Buffer Operation Timing: Figures 17.36 and 17.37 show the timing in buffer operation.

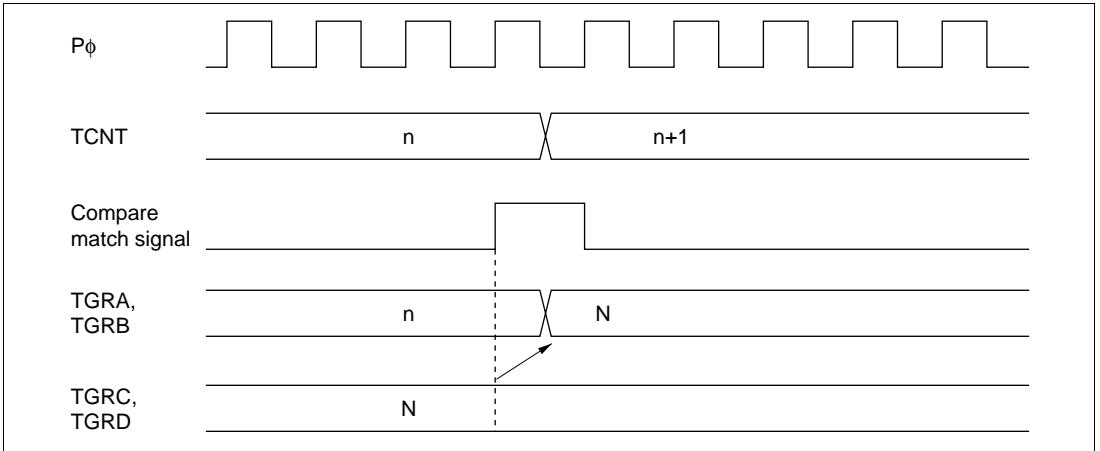

Figure 17.36 Buffer Operation Timing (Compare Match)

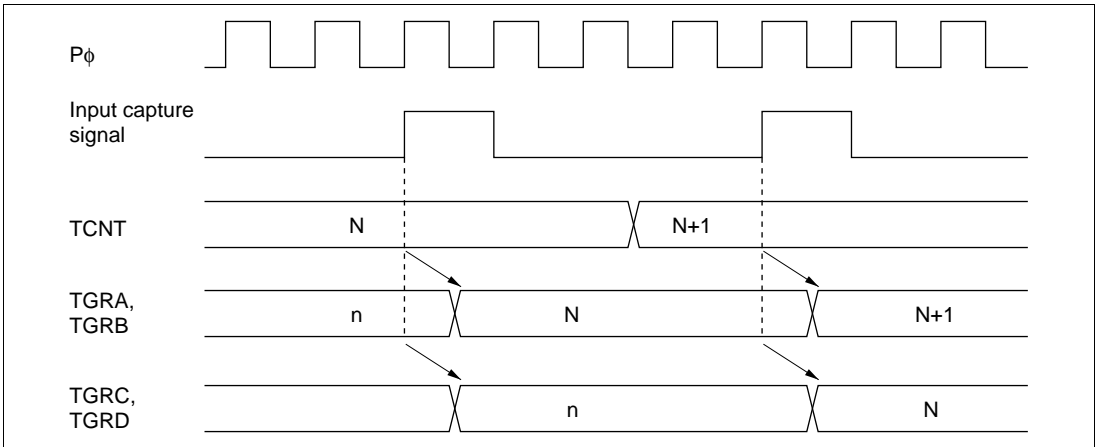

Figure 17.37 Buffer Operation Timing (Input Capture)

17.6.2 Interrupt Signal Timing

TGF Flag Setting Timing in Case of Compare Match: Figure 17.38 shows the timing for setting of the TGF flag in TSR by compare match occurrence, and TGI interrupt request signal timing.

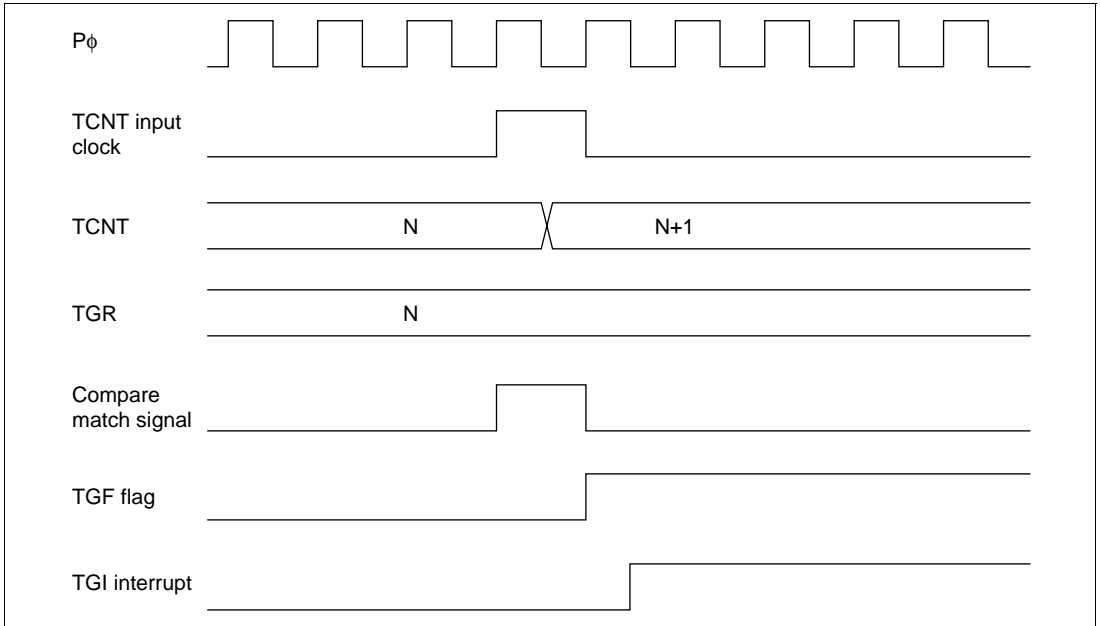

Figure 17.38 TGI Interrupt Timing (Compare Match)

TGF Flag Setting Timing in Case of Input Capture: Figure 17.39 shows the timing for setting of the TGF flag in TSR by input capture occurrence, and TGI interrupt request signal timing.

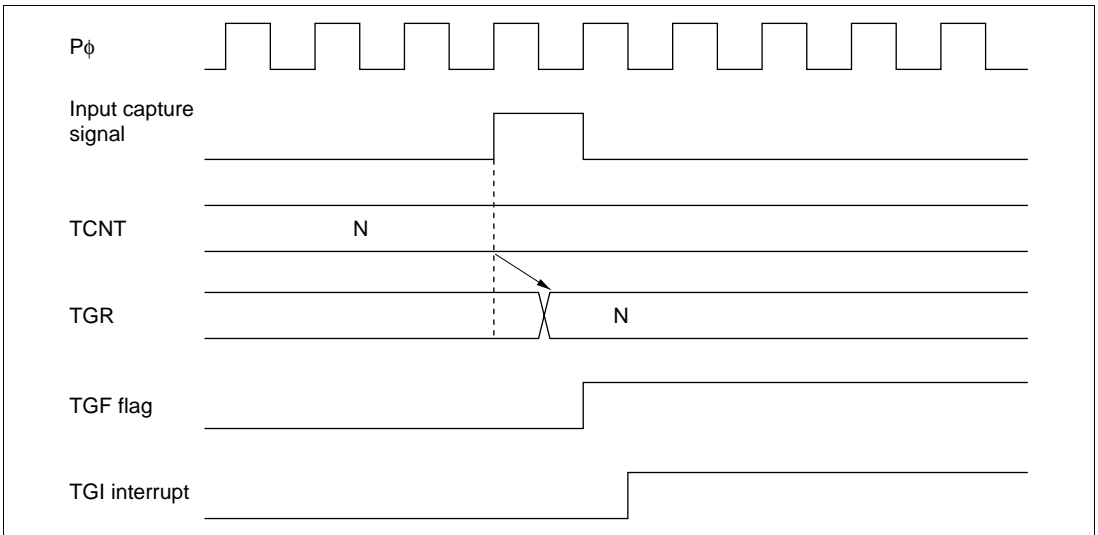

Figure 17.39 TGI Interrupt Timing (Input Capture)

TCFV Flag/TCFU Flag Setting Timing: Figure 17.40 shows the timing for setting of the TCFV flag in TSR by overflow occurrence, and TCIV interrupt request signal timing.

Figure 17.41 shows the timing for setting of the TCFU flag in TSR by underflow occurrence, and TCIU interrupt request signal timing.

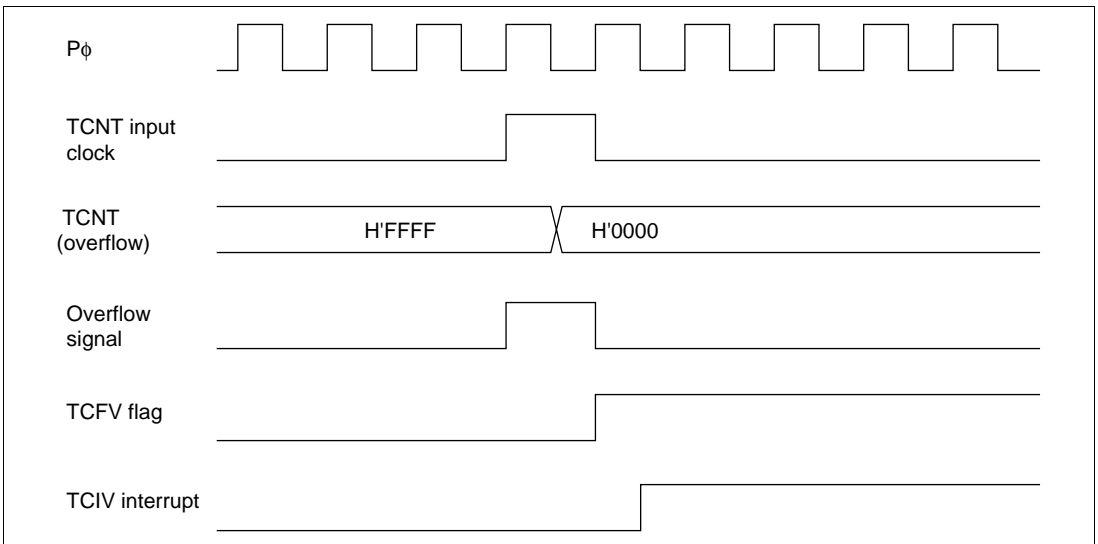

Figure 17.40 TCIV Interrupt Setting Timing

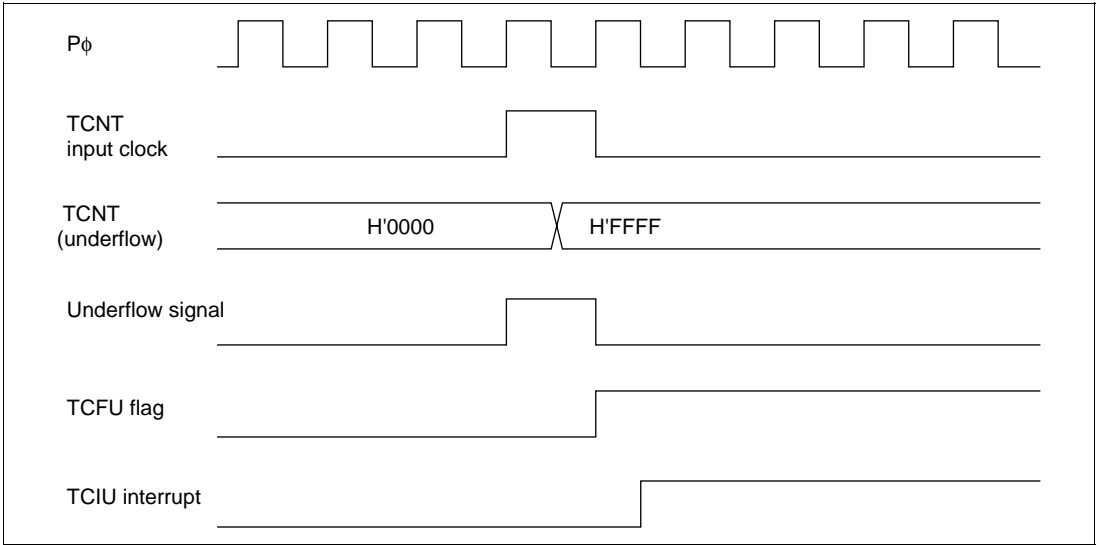

Figure 17.41 TCIU Interrupt Setting Timing

Status Flag Clearing Timing: After a status flag is read as 1 by the CPU, it is cleared by writing 0 to it. When the DMAC is activated, the flag is cleared automatically. Figure 17.42 shows the timing for status flag clearing by the CPU, and figure 17.43 shows the timing for status flag clearing by the DMAC.

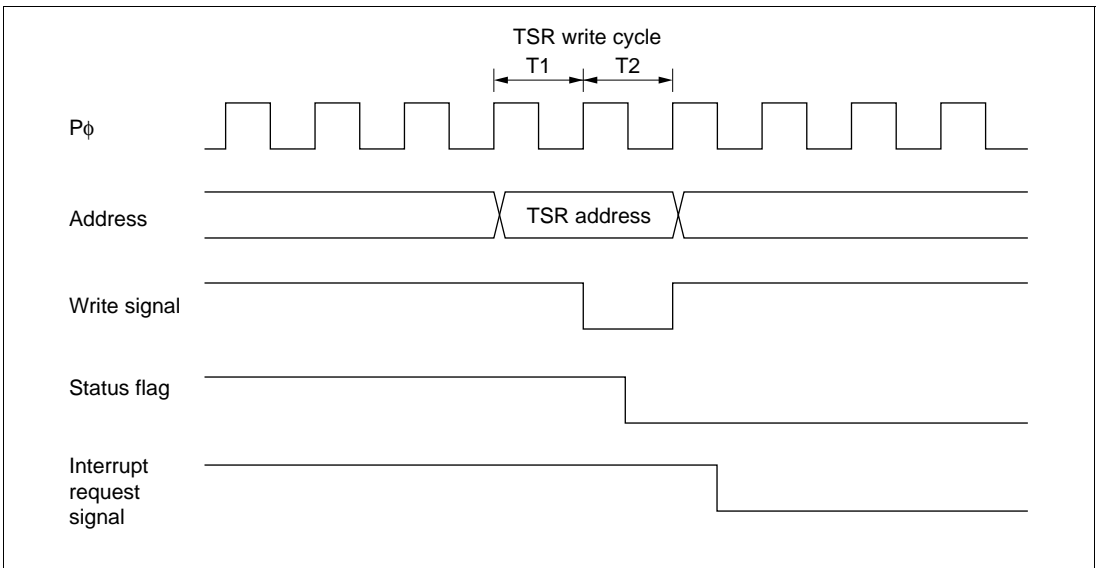

Figure 17.42 Timing for Status Flag Clearing by CPU

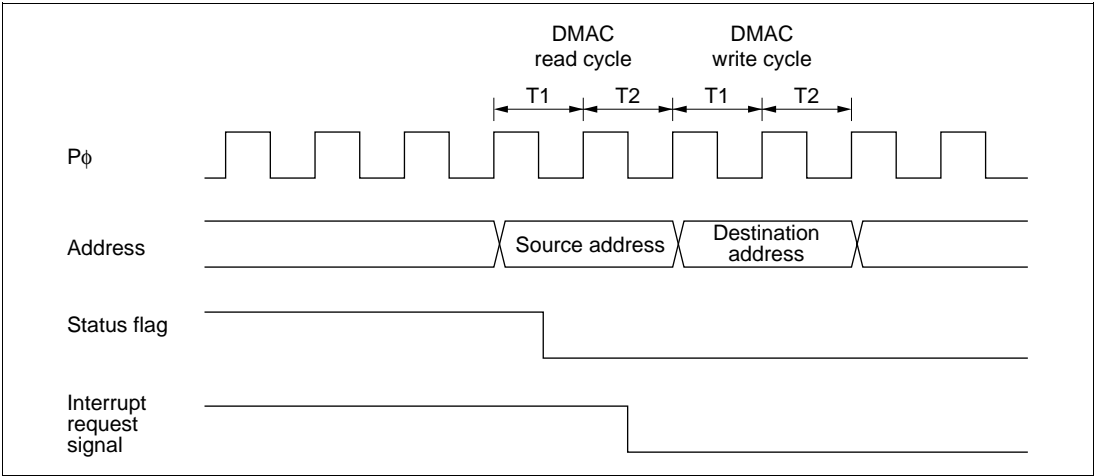

Figure 17.43 Timing for Status Flag Clearing by DMAC Activation

17.7 Usage Notes

Note that the kinds of operation and contention described below occur during TPU operation.

Input Clock Restrictions: The input clock pulse width must be at least 1.5 states in the case of single-edge detection, and at least 2.5 states in the case of both-edge detection. The TPU will not operate properly with a narrower pulse width.

In phase counting mode, the phase difference and overlap between the two input clocks must be at least 1.5 states, and the pulse width must be at least 2.5 states. Figure 17.44 shows the input clock conditions in phase counting mode.

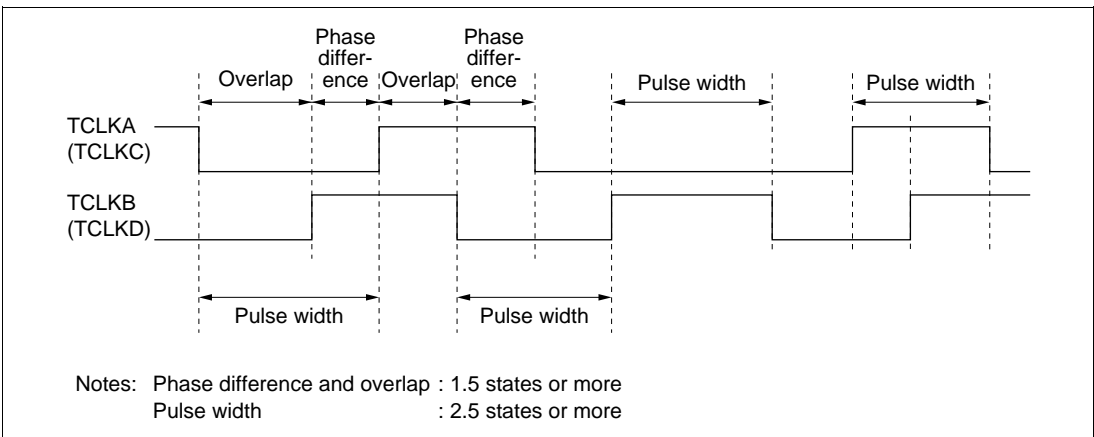

Figure 17.44 Phase Difference, Overlap, and Pulse Width in Phase Counting Mode

Caution on Period Setting: When counter clearing by compare match is set, TCNT is cleared in the final state in which it matches the TGR value (the point at which the count value matched by TCNT is updated). Consequently, the actual counter frequency is given by the following formula:

$$f = \frac{P\phi}{(N + 1)}$$

Where f : Counter frequency
 $P\phi$: Peripheral module clock
 N : TGR set value

Contention between TCNT Write and Clear Operations: If the counter clear signal is generated in the T2 state of a TCNT write cycle, TCNT clearing takes precedence and the TCNT write is not performed.

Figure 17.45 shows the timing in this case.

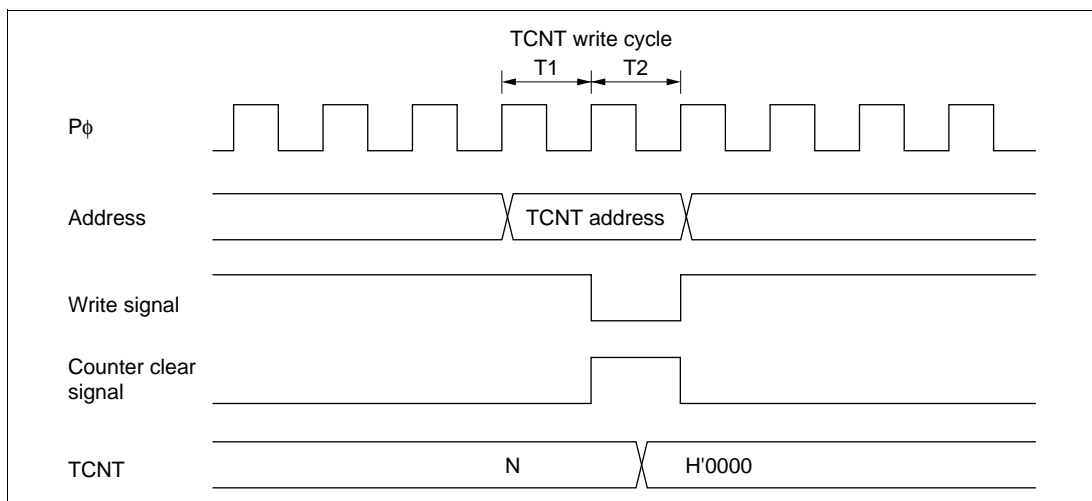

Figure 17.45 Contention between TCNT Write and Clear Operations

Contention between TCNT Write and Increment Operations: If incrementing occurs in the T2 state of a TCNT write cycle, the TCNT write takes precedence and TCNT is not incremented.

Figure 17.46 shows the timing in this case.

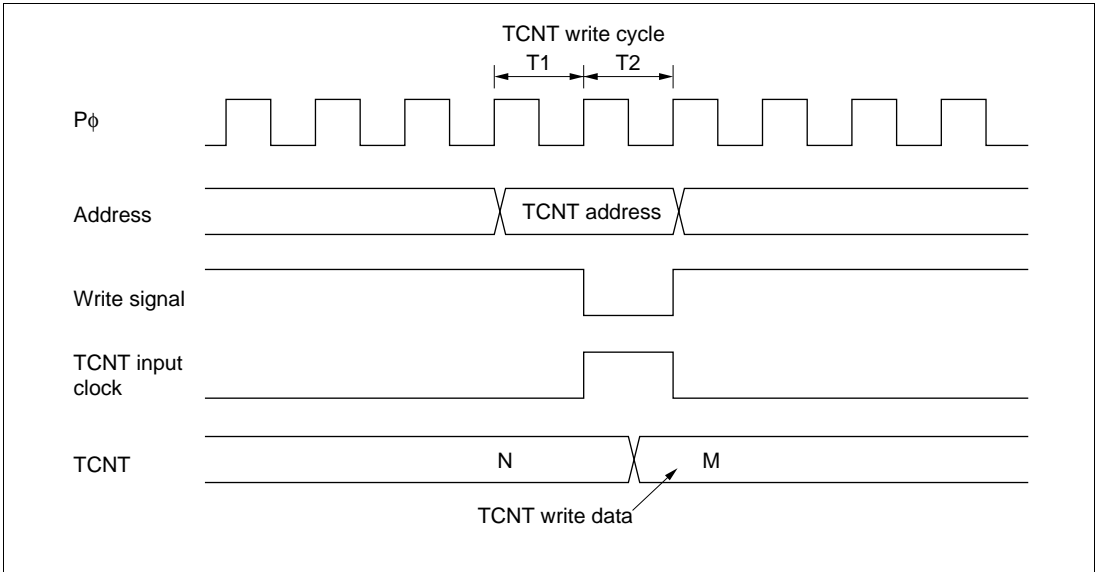

Figure 17.46 Contention between TCNT Write and Increment Operations

Contention between TGR Write and Compare Match: If a compare match occurs in the T2 state of a TGR write cycle, the TGR write takes precedence and the compare match signal is inhibited. A compare match does not occur even if the same value as before is written.

Figure 17.47 shows the timing in this case.

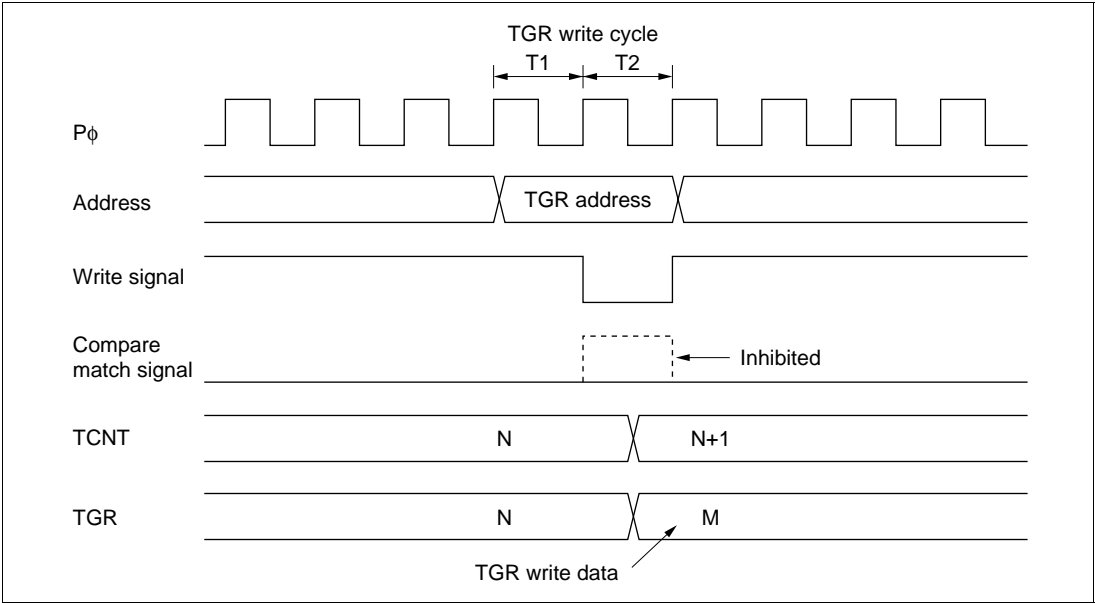

Figure 17.47 Contention between TGR Write and Compare Match

Contention between Buffer Register Write and Compare Match: If a compare match occurs in the T2 state of a TGR write cycle, the data transferred to TGR by the buffer operation will be the write data.

Figure 17.48 shows the timing in this case.

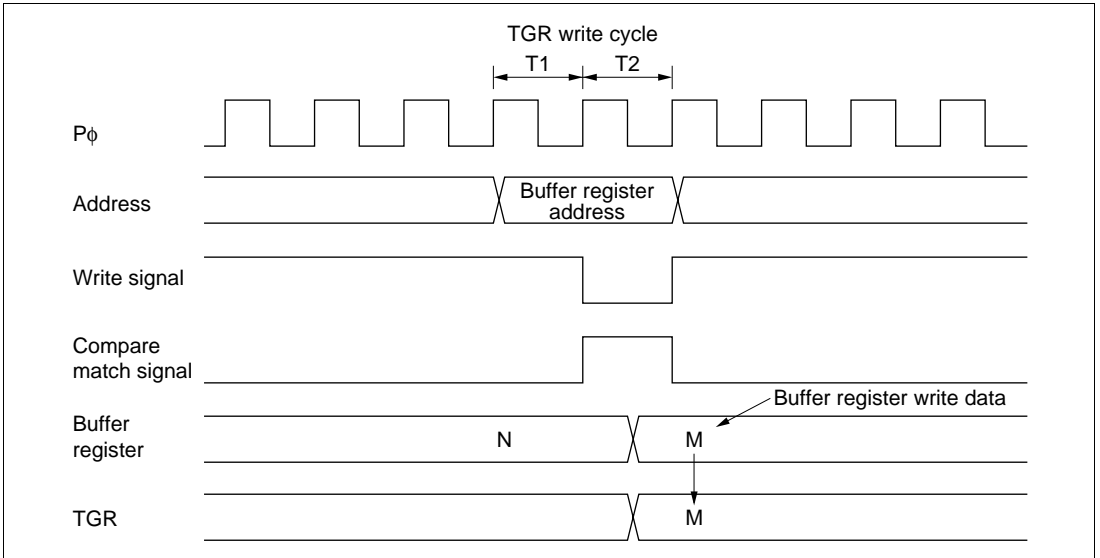

Figure 17.48 Contention between Buffer Register Write and Compare Match

Contention between TGR Read and Input Capture: If the input capture signal is generated in the T1 state of a TGR read cycle, the data that is read will be the data before input capture transfer.

Figure 17.49 shows the timing in this case.

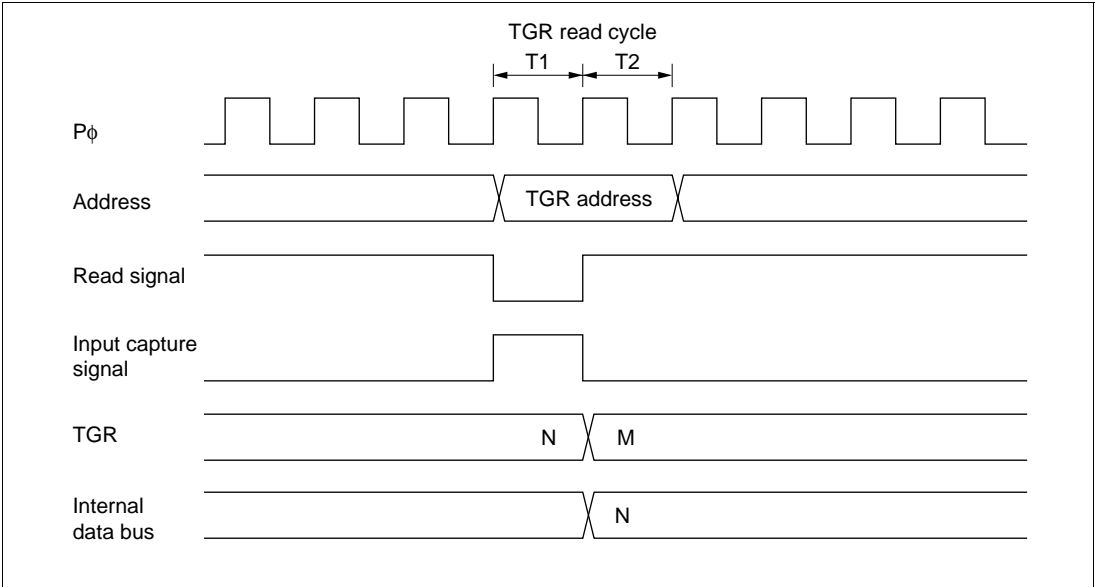

Figure 17.49 Contention between TGR Read and Input Capture

Contention between TGR Write and Input Capture: If the input capture signal is generated in the T2 state of a TGR write cycle, the input capture operation takes precedence and the write to TGR is not performed.

Figure 17.50 shows the timing in this case.

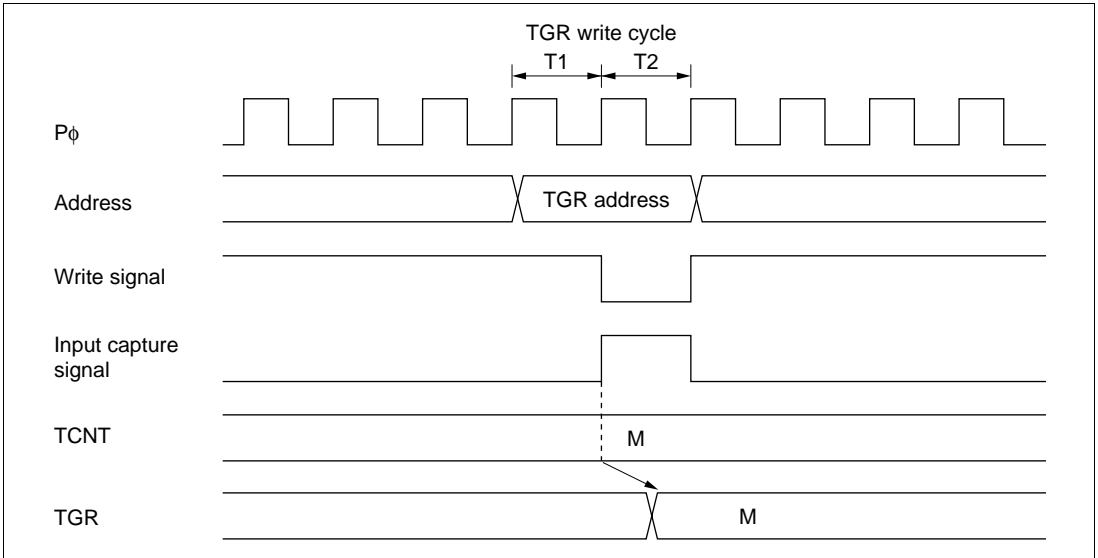

Figure 17.50 Contention between TGR Write and Input Capture

Contention between Buffer Register Write and Input Capture: If the input capture signal is generated in the T2 state of a buffer register write cycle, the buffer operation takes precedence and the write to the buffer register is not performed.

Figure 17.51 shows the timing in this case.

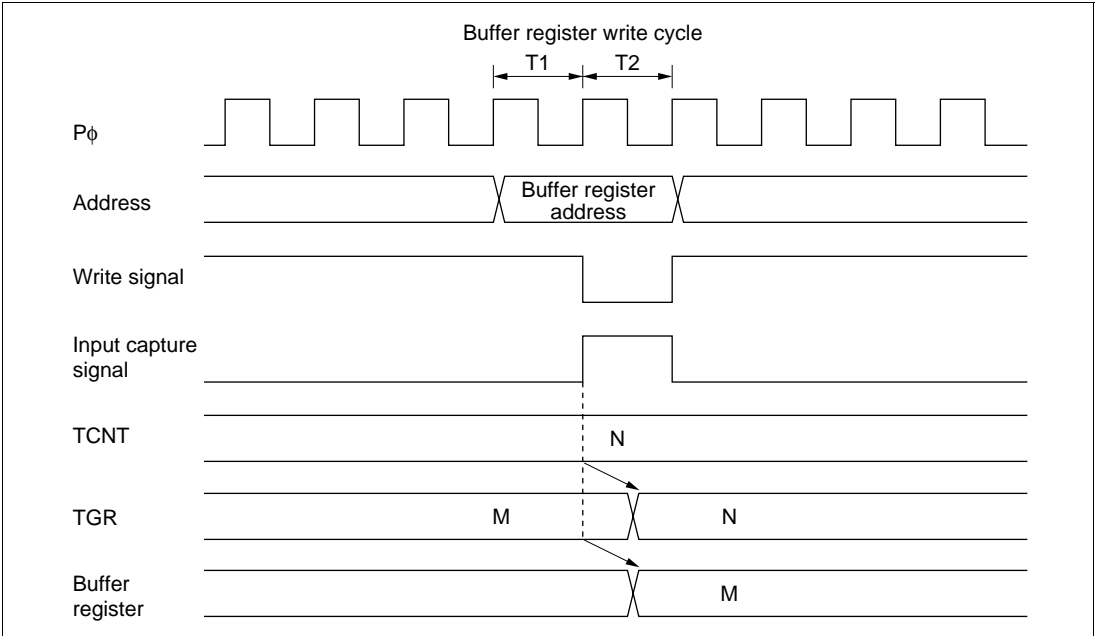

Figure 17.51 Contention between Buffer Register Write and Input Capture

Contention between Overflow/Underflow and Counter Clearing: If overflow/underflow and counter clearing occur simultaneously, the TCFV/TCFU flag in TSR is not set and TCNT clearing takes precedence.

Figure 17.52 shows the operation timing when a TGR compare match is specified as the clearing source, and H'FFFF is set in TGR.

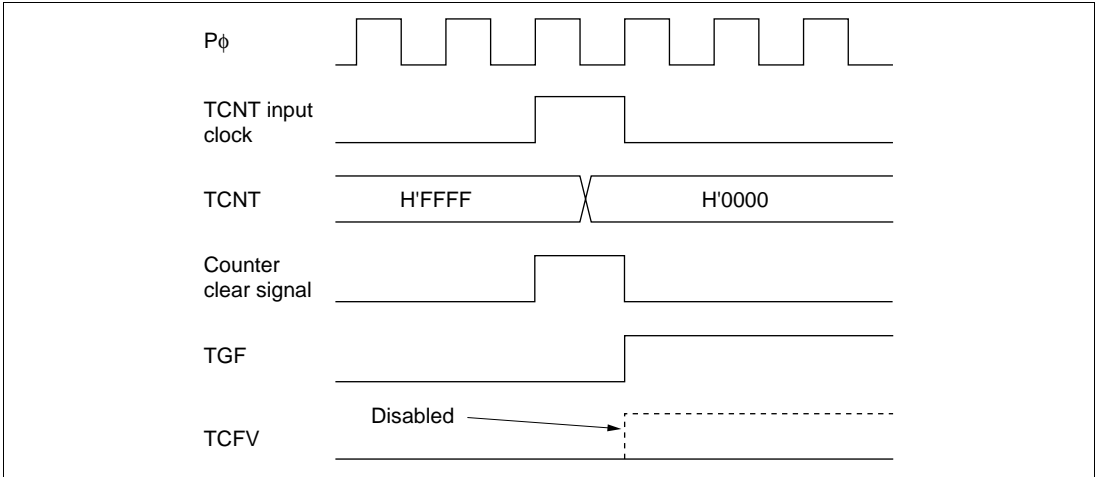

Figure 17.52 Contention between Overflow and Counter Clearing

Contention between TCNT Write and Overflow/Underflow: If there is an up-count or down-count in the T2 state of a TCNT write cycle, and overflow/underflow occurs, the TCNT write takes precedence and the TCFV/TCFU flag in TSR is not set .

Figure 17.53 shows the operation timing in the case of contention between a TCNT write and overflow.

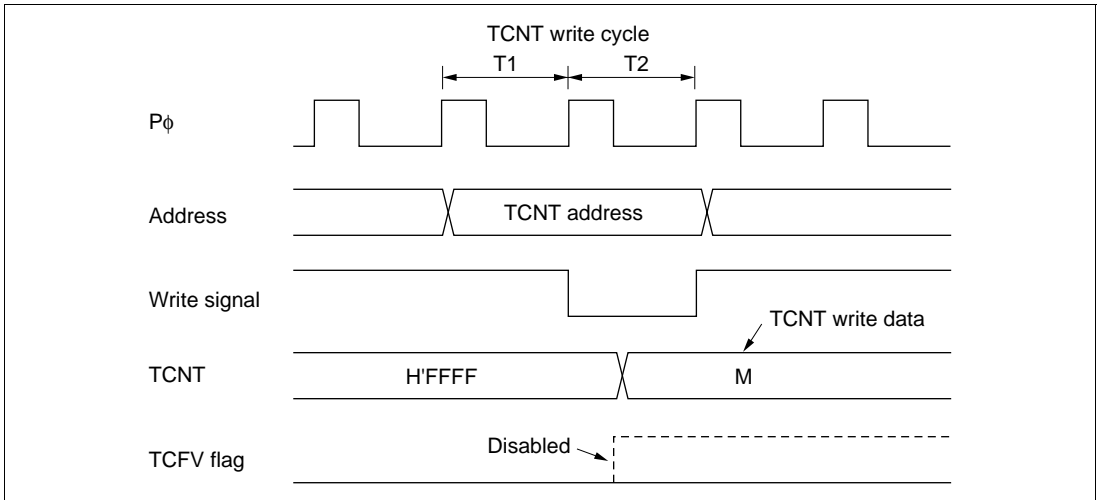

Figure 17.53 Contention between TCNT Write and Overflow

Multiplexing of I/O Pins: In the Chip, the TCLKA input pin is multiplexed with the TIOCC0 I/O pin, the TCLKB input pin with the TIOCD0 I/O pin, the TCLKC input pin with the TIOCB1 I/O pin, and the TCLKD input pin with the TIOCB2 I/O pin. When an external clock is input, compare match output should not be performed from a multiplexed pin.

Interrupts and Module Stop Mode: If module stop mode is entered when an interrupt has been requested, it will not be possible to clear the CPU interrupt source or DMAC activation source. Interrupts should therefore be disabled before entering module stop mode.

17.8 Usage Notes

17.8.1 Clearing Flags in TSR0 to TSR2

When bits TCFV, TGFD, TGFC, TGFB, and TGFA in TSR0, and bits TCFU, TCFV, TGFB, and TGFA in TSR1 and TSR2, are cleared, it may happen that the interrupt request in the internal logic cannot be cleared although the flag is cleared. In this case, if interrupt acceptance is enabled, another interrupt will be generated.

Either of the following measures should therefore be taken when clearing flags in TSR0 to TSR2.

1. Execute clearing while the TPU timer is counting up.
2. If clearing when the TPU timer is stopped, write 0 to the flag again after executing clearing.

17.8.2 DMA Transfer by TPU0

When DMA transfer is performed by means of TPU channel 0 compare match or input capture, internal logic interrupt requests (transfer requests) may not be cleared correctly. Therefore, it may not be possible to execute DMA transfer when a subsequent transfer request is generated by TPU channel 0 compare match or input capture.

Either of the following measures should therefore be taken when performing DMA transfer by means of TPU channel 0 compare match or input capture.

1. Do not set on-chip RAM as the DMA transfer source or destination.
2. When on-chip RAM has not been set as the DMA transfer source or destination, execute the transfer while the TPU channel 0 timer is counting up.

Section 18 Hitachi User Debug Interface (H-UDI)

18.1 Overview

The Hitachi user debug interface (H-UDI) provides data transfer and interrupt request functions. The H-UDI performs serial transfer by means of external signal control.

18.1.1 Features

The H-UDI has the following features conforming to the IEEE 1149.1 standard.

- Five test signals (TCK, TDI, TDO, TMS, and $\overline{\text{TRST}}$)
- TAP controller
- Instruction register
- Data register
- Bypass register
- Boundary scan register

The H-UDI has seven instructions.

- Bypass mode
Test mode conforming to IEEE 1149.1
- EXTEST mode
Test mode corresponding to IEEE1149.1.
- SAMPLE/PRELOAD mode
Test mode corresponding to IEEE1149.1.
- CLAMP mode
Test mode corresponding to IEEE1149.1.
- HIGHZ mode
Test mode corresponding to IEEE1149.1.
- IDCODE mode
Test mode corresponding to IEEE1149.1.
- H-UDI interrupt
H-UDI interrupt request to INTC

This chip does not support test modes other than bypass mode.

18.1.2 H-UDI Block Diagram

Figure 18.1 shows a block diagram of the H-UDI.

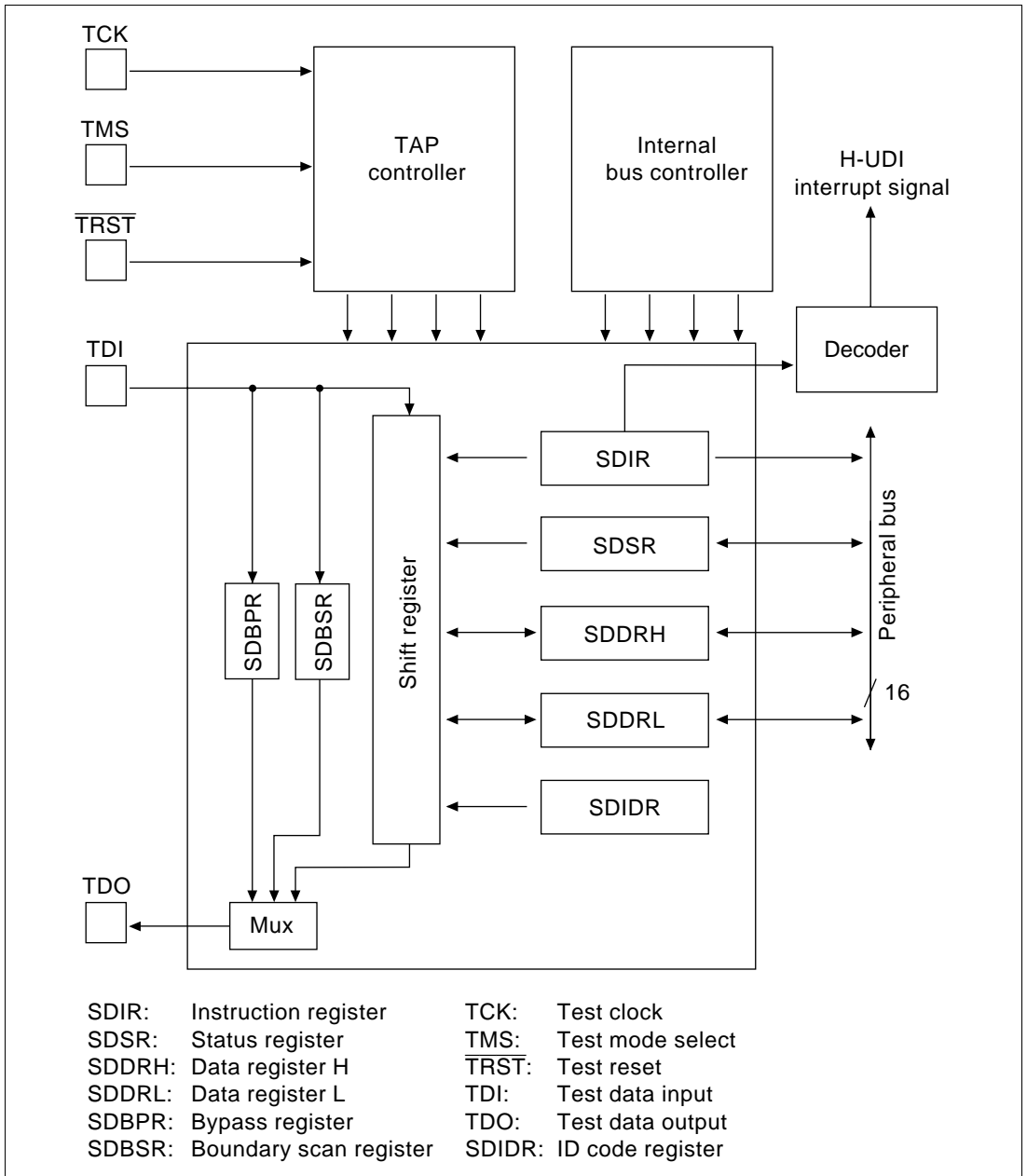

Figure 18.1 H-UDI Block Diagram

18.1.3 Pin Configuration

Table 18.1 shows the H-UDI pin configuration.

Table 18.1 Pin Configuration

Pin Name	Abbreviation	I/O	Function
Test clock	TCK	Input	Test clock input
Test mode select	TMS	Input	Test mode select input signal
Test data input	TDI	Input	Serial data input
Test data output	TDO	Output	Serial data output
Test reset	$\overline{\text{TRST}}$	Input	Test reset input signal

18.1.4 Register Configuration

Table 18.2 shows the H-UDI registers.

Table 18.2 Register Configuration

Register	Abbreviation	R/W* ¹	Initial Value* ²	Address	Access Size (Bits)
Instruction register	SDIR	R	H'E000	H'FFFFFFCB0	8/16/32
Status register	SDSR	R/W	H'0701	H'FFFFFFCB2	8/16/32
Data register H	SDDRH	R/W	Undefined	H'FFFFFFCB4	8/16/32
Data register L	SDDRL	R/W	Undefined	H'FFFFFFCB6	8/16/32
Bypass register	SDBPR	—	—	—	—
Boundary scan register	SDBSR	—	—	—	—
ID code register	SDIDR	—	H'0005200F	—	—

Notes: *1 Indicates whether the register can be read/written to by the CPU.

*2 Initial value when the $\overline{\text{TRST}}$ signal is input. Registers are not initialized by a reset (power-on or manual) or in standby mode.

Instructions and data can be input to the instruction register (SDIR) and data register (SDDR) by serial transfer from the test data input pin (TDI). Data from SDIR, the status register (SDSR), and SDDR can be output via the test data output pin (TDO). The bypass register (SDBPR) is a 1-bit register to which TDI and TDO are connected in bypass mode. The boundary scan register (SDBSR) is a 330-bit register, and is connected to TDI and TDO in the SAMPLE/PRELOAD or EXTTEST mode. The ID code register (SDIDR) is a 32-bit register; a fixed code can be output via

TDO in the IDCODE mode. All registers, except SDBPR, SDBSR, and SDIDR, can be accessed from the CPU.

Table 18.3 shows the kinds of serial transfer possible with each register.

Table 18.3 H-UDI Register Serial Transfer

Register	Serial Input	Serial Output
SDIR	Possible	Possible
SDSR	Impossible	Possible
SDDRH	Possible	Possible
SDDRL	Possible	Possible
SDBPR	Possible	Possible
SDBSR	Possible	Possible
SDIDR	Impossible	Possible

18.2 External Signals

18.2.1 Test Clock (TCK)

The test clock pin (TCK) provides an independent clock supply to the H-UDI. As the clock input to TCK is supplied directly to the H-UDI, a clock waveform with a duty cycle close to 50% should be input (for details, see section 22, Electrical Characteristics). If no clock is input, TCK is fixed at 1 by internal pull-up.

18.2.2 Test Mode Select (TMS)

The test mode select pin (TMS) is sampled on the rise of TCK. TMS controls the internal state of the TAP controller. If no signal is input, TMS is fixed at 1 by internal pull-up.

18.2.3 Test Data Input (TDI)

The test data input pin (TDI) performs serial input of instructions and data for H-UDI registers. TDI is sampled on the rise of TCK. If no signal is input, TDI is fixed at 1 by internal pull-up.

18.2.4 Test Data Output (TDO)

The test data output pin (TDO) performs serial output of instructions and data from H-UDI registers. Transfer is performed in synchronization with TCK. If there is no output, TDO goes to the high-impedance state.

18.2.5 Test Reset ($\overline{\text{TRST}}$)

The test reset pin ($\overline{\text{TRST}}$) initializes the H-UDI asynchronously. If no signal is input, $\overline{\text{TRST}}$ is fixed at 1 by internal pull-up.

18.3 Register Descriptions

18.3.1 Instruction Register (SDIR)

Bit:	15	14	13	12	11	10	9	8
	TS3	TS2	TS1	TS0	—	—	—	—
Initial value:	1	1	1	0	0	0	0	0
R/W:	R	R	R	R	R	R	R	R
Bit:	7	6	5	4	3	2	1	0
	—	—	—	—	—	—	—	—
Initial value:	0	0	0	0	0	0	0	0
R/W:	R	R	R	R	R	R	R	R

The instruction register (SDIR) is a 16-bit register that can only be read by the CPU. H-UDI instructions can be transferred to SDIR by serial input from TDI. SDIR can be initialized by the $\overline{\text{TRST}}$ signal, but is not initialized by a reset or in standby mode.

SDIR defines 4 valid bits for instruction. If an instruction exceeding 4 bits is input, the last 4 bits of the serial data will be stored in SDIR.

Operation is not guaranteed if a reserved instruction is set in this register.

Bits 15 to 12—Test Set Bits (TS3–TS0): Table 18.4 shows the instruction configuration.

Table 18.4 Instruction Configuration

Bit 15: TS3	Bit 14: TS2	Bit 13: TS1	Bit 12: TS0	Description
0	0	0	0	EXTEST mode
			1	Reserved
		1	0	CLAMP mode
			1	HIGHZ mode
	1	0	0	SAMPLE/PRELOAD mode
			1	Reserved
		1	0	Reserved
			1	Reserved
1	0	0	0	Reserved
			1	Reserved
		1	0	H-UDI interrupt
			1	Reserved
	1	0	0	Reserved
			1	Reserved
		1	0	IDCODE mode (Initial value)
			1	BYPASS mode

Bits 11 to 0—Reserved: These bits are always read as 0. The write value should always be 0.

18.3.2 Status Register (SDSR)

Bit:	15	14	13	12	11	10	9	8
	—	—	—	—	—	—	—	—
Initial value:	0	0	0	0	0	1	1	1
R/W:	R	R	R	R	R	R	R	R
Bit:	7	6	5	4	3	2	1	0
	—	—	—	—	—	—	—	SDTRF
Initial value:	0	0	0	0	0	0	0	1
R/W:	R	R	R	R	R	R	R	R/W

The status register (SDSR) is a 16-bit register that can be read and written to by the CPU. Output from TDO is possible for SDSR, but serial data cannot be written to SDSR via TDI. The SDTRF bit is output by means of a 1-bit shift. In the case of a 2-bit shift, the SDTRF bit is first output, followed by a reserved bit.

SDSR is initialized by $\overline{\text{TRST}}$ signal input, but is not initialized by a reset or in standby mode.

Bits 15 to 1—Reserved: Bits 15 to 11 and 7 to 1 are always read as 0, and the write value should always be 0. Bits 10 to 8 are always read as 1, and the write value should always be 1.

Bit 0—Serial Data Transfer Control Flag (SDTRF): Indicates whether H-UDI registers can be accessed by the CPU. The SDTRF bit is reset by the $\overline{\text{TRST}}$ signal, but is not initialized by a reset or in standby mode.

Bit 0: SDTRF	Description
0	Serial transfer to SDDR has ended, and SDDR can be accessed
1	Serial transfer to SDDR in progress (Initial value)

18.3.3 Data Register (SDDR)

The data register (SDDR) comprises data register H (SDDRH) and data register L (SDDRL), each of which has the following configuration.

Bit:	15	14	13	12	11	10	9	8
Initial value:	—	—	—	—	—	—	—	—
R/W:	R/W	R/W	R/W	R/W	R/W	R/W	R/W	R/W
Bit:	7	6	5	4	3	2	1	0
Initial value:	—	—	—	—	—	—	—	—
R/W:	R/W	R/W	R/W	R/W	R/W	R/W	R/W	R/W

SDDRH and SDDRL are 16-bit registers that can be read and written to by the CPU. SDDR is connected to TDO and TDI for serial data transfer to and from an external device.

32-bit data is input and output in serial data transfer. If data exceeding 32 bits is input, only the last 32 bits will be stored in SDDR. Serial data is input starting from the MSB of SDDR (bit 15 of SDDRH), and output starting from the LSB (bit 0 of SDDRL).

This register is not initialized by a reset, in standby mode, or by the $\overline{\text{TRST}}$ signal.

18.3.4 Bypass Register (SDBPR)

The bypass register (SDBPR) is a one-bit shift register. In bypass mode, SDBPR is connected to TDI and TDO, and the chip is excluded from the board test when a boundary scan test is conducted. SDBPR cannot be read or written to by the CPU.

18.3.5 Boundary scan register (SDBSR)

The boundary scan register (SDBSR), a shift register that controls the I/O terminals of this LSI, is provided on the PAD.

Using the EXTEST mode or the SAMPLE/PRELOAD mode, a boundary scan test conforming to the IEEE1149.1 standard can be performed.

For SDBSR, read/write by the CPU cannot be performed.

Table 18.5 shows the relationship between the terminals of the LSI and the boundary scan register.

Table 18.5 Correspondence between Pins and Boundary Scan Register Bits

Pin No.	Pin Name	Input/Output	Bit No.
from TDI			
34	D0	Input	329
		Output	328
		Output enable	327
36	D1	Input	326
		Output	325
		Output enable	324
37	D2	Input	323
		Output	322
		Output enable	321
38	D3	Input	320
		Output	319
		Output enable	318
39	D4	Input	317
		Output	316
		Output enable	315
40	D5	Input	314
		Output	313
		Output enable	312
41	D6	Input	311
		Output	310
		Output enable	309
43	D7	Input	308
		Output	307
		Output enable	306
44	D8	Input	305
		Output	304
		Output enable	303
46	D9	Input	302
		Output	301
		Output enable	300

Table 18.5 Correspondence between Pins and Boundary Scan Register Bits (cont)

Pin No.	Pin Name	Input/Output	Bit No.
47	D10	Input	299
		Output	298
		Output enable	297
48	D11	Input	296
		Output	295
		Output enable	294
49	D12	Input	293
		Output	292
		Output enable	291
51	D13	Input	290
		Output	289
		Output enable	288
53	D14	Input	287
		Output	286
		Output enable	285
54	D15	Input	284
		Output	283
		Output enable	282
55	D16	Input	281
		Output	280
		Output enable	279
56	D17	Input	278
		Output	277
		Output enable	276
57	D18	Input	275
		Output	274
		Output enable	273
59	D19	Input	272
		Output	271
		Output enable	270

Table 18.5 Correspondence between Pins and Boundary Scan Register Bits (cont)

Pin No.	Pin Name	Input/Output	Bit No.
62	D20	Input	269
		Output	268
		Output enable	267
63	D21	Input	266
		Output	265
		Output enable	264
64	D22	Input	263
		Output	262
		Output enable	261
65	D23	Input	260
		Output	259
		Output enable	258
68	D24	Input	257
		Output	256
		Output enable	255
70	D25	Input	254
		Output	253
		Output enable	252
71	D26	Input	251
		Output	250
		Output enable	249
72	D27	Input	248
		Output	247
		Output enable	246
73	D28	Input	245
		Output	244
		Output enable	243
74	D29	Input	242
		Output	241
		Output enable	240

Table 18.5 Correspondence between Pins and Boundary Scan Register Bits (cont)

Pin No.	Pin Name	Input/Output	Bit No.
75	D30	Input	239
		Output	238
		Output enable	237
77	D31	Input	236
		Output	235
		Output enable	234
80	A0	Output	233
		Output enable	232
82	A1	Output	231
		Output enable	230
83	A2	Output	229
		Output enable	228
84	A3	Output	227
		Output enable	226
85	A4	Output	225
		Output enable	224
86	A5	Output	223
		Output enable	222
87	A6	Output	221
		Output enable	220
88	A7	Output	219
		Output enable	218
90	A8	Output	217
		Output enable	216
92	A9	Output	215
		Output enable	214
93	A10	Output	213
		Output enable	212
94	A11	Output	211
		Output enable	210

Table 18.5 Correspondence between Pins and Boundary Scan Register Bits (cont)

Pin No.	Pin Name	Input/Output	Bit No.
95	A12	Output	209
		Output enable	208
96	A13	Output	207
		Output enable	206
97	A14	Output	205
		Output enable	204
98	A15	Output	203
		Output enable	202
100	A16	Output	201
		Output enable	200
102	A17	Output	199
		Output enable	198
103	A18	Output	197
		Output enable	196
104	A19	Output	195
		Output enable	194
105	A20	Output	193
		Output enable	192
106	A21	Output	191
		Output enable	190
107	A22	Output	189
		Output enable	188
108	A23	Output	187
		Output enable	186
111	A24	Output	185
		Output enable	184
115	$\overline{\text{WAIT}}$	Input	183
117	$\overline{\text{RAS}}$	Output	182
		Output enable	181
118	$\overline{\text{CAS}}$	Output	180
		Output enable	179

Table 18.5 Correspondence between Pins and Boundary Scan Register Bits (cont)

Pin No.	Pin Name	Input/Output	Bit No.
119	DQMUU/ $\overline{\text{WE3}}$	Output	178
		Output enable	177
120	DQMUL/ $\overline{\text{WE2}}$	Output	176
		Output enable	175
121	DQMLU/ $\overline{\text{WE1}}$	Output	174
		Output enable	173
122	DQMLL/ $\overline{\text{WE0}}$	Output	172
		Output enable	171
123	$\overline{\text{CAS3}}$	Output	170
		Output enable	169
124	$\overline{\text{CAS2}}$	Output	168
		Output enable	167
125	$\overline{\text{CAS1}}$	Output	166
		Output enable	165
126	$\overline{\text{CAS0}}$	Output	164
		Output enable	163
127	CKE	Output	162
		Output enable	161
128	$\overline{\text{RD}}$	Output	160
		Output enable	159
129	REFOUT	Output	158
		Output enable	157
131	$\overline{\text{BS}}$	Output	156
		Output enable	155
133	RD/ $\overline{\text{WR}}$	Output	154
		Output enable	153
134	$\overline{\text{CS0}}$	Output	152
		Output enable	151
135	$\overline{\text{CS1}}$	Output	150
		Output enable	149

Table 18.5 Correspondence between Pins and Boundary Scan Register Bits (cont)

Pin No.	Pin Name	Input/Output	Bit No.
136	$\overline{\text{CS2}}$	Output	148
		Output enable	147
137	$\overline{\text{CS3}}$	Output	146
		Output enable	145
138	$\overline{\text{CS4}}$	Output	144
		Output enable	143
139	$\overline{\text{BUSHIZ}}$	Input	142
140	$\overline{\text{BH}}$	Output	141
		Output enable	140
141	DREQ1	Input	139
142	DREQ0	Input	138
143	DACK1	Output	137
		Output enable	136
144	DACK0	Output	135
		Output enable	134
145	$\overline{\text{BRLS}}$	Input	133
148	$\overline{\text{BGR}}$	Output	132
		Output enable	131
151	PB15	Input	130
		Output	129
		Output enable	128
152	PB14	Input	127
		Output	126
		Output enable	125
153	PB13	Input	124
		Output	123
		Output enable	122
154	PB12	Input	121
		Output	120
		Output enable	119

Table 18.5 Correspondence between Pins and Boundary Scan Register Bits (cont)

Pin No.	Pin Name	Input/Output	Bit No.
156	PB11	Input	118
		Output	117
		Output enable	116
158	PB10	Input	115
		Output	114
		Output enable	113
159	PB9	Input	112
		Output	111
		Output enable	110
160	PB8	Input	109
		Output	108
		Output enable	107
161	PB7	Input	106
		Output	105
		Output enable	104
162	PB6	Input	103
		Output	102
		Output enable	101
163	PB5	Input	100
		Output	99
		Output enable	98
164	PB4	Input	97
		Output	96
		Output enable	95
165	PB3	Input	94
		Output	93
		Output enable	92
166	PB2	Input	91
		Output	90
		Output enable	89

Table 18.5 Correspondence between Pins and Boundary Scan Register Bits (cont)

Pin No.	Pin Name	Input/Output	Bit No.
168	PB1	Input	88
		Output	87
		Output enable	86
170	PB0	Input	85
		Output	84
		Output enable	83
171	PA13	Input	82
		Output	81
		Output enable	80
172	PA12	Input	79
		Output	78
		Output enable	77
173	PA11	Input	76
		Output	75
		Output enable	74
174	PA10	Input	73
		Output	72
		Output enable	71
175	PA9	Input	70
		Output	69
		Output enable	68
176	PA8	Input	67
		Output	66
		Output enable	65
177	PA7	Input	64
		Output	63
		Output enable	62
178	PA6	Input	61
		Output	60
		Output enable	59

Table 18.5 Correspondence between Pins and Boundary Scan Register Bits (cont)

Pin No.	Pin Name	Input/Output	Bit No.
180	PA5	Input	58
		Output	57
		Output enable	56
182	PA4	Input	55
		Output	54
		Output enable	53
183	CKPO	Output	52
		Output enable	51
184	PA2	Input	50
		Output	49
		Output enable	48
185	PA1	Input	47
		Output	46
		Output enable	45
186	PA0	Input	44
		Output	43
		Output enable	42
187	RX-ER	Input	41
188	RX-DV	Input	40
189	COL	Input	39
190	CRS	Input	38
192	RX-CLK	Input	37
194	ERXD0	Input	36
195	ERXD1	Input	35
196	ERXD2	Input	34
197	ERXD3	Input	33
198	MDIO	Input	32
		Output	31
		Output enable	30
199	MDC	Output	29
		Output enable	28

Table 18.5 Correspondence between Pins and Boundary Scan Register Bits (cont)

Pin No.	Pin Name	Input/Output	Bit No.
201	TX-CLK	Input	27
203	TX-EN	Output	26
		Output enable	25
204	ETXD0	Output	24
		Output enable	23
205	ETXD1	Output	22
		Output enable	21
206	ETXD2	Output	20
		Output enable	19
207	ETXD3	Output	18
		Output enable	17
208	TX-ER	Output	16
		Output enable	15
1	$\overline{\text{IRL3}}$	Input	14
2	$\overline{\text{IRL2}}$	Input	13
3	$\overline{\text{IRL1}}$	Input	12
4	$\overline{\text{IRL0}}$	Input	11
5	NMI	Input	10
13	MD4	Input	9
14	MD3	Input	8
15	MD2	Input	7
16	MD1	Input	6
17	MD0	Input	5
24	$\overline{\text{CKPREQ/CKM}}$	Input	4
25	CKPACK	Output	3
		Output enable	2
27	$\overline{\text{IVECF}}$	Output	1
		Output enable	0

to TDO

Note: The output enable signals are active-low. When an output enable signal is driven low, the corresponding pin is driven. The exception is the output enable signal for the MDIO pin, which is active-high.

18.3.6 ID code register (SDIDR)

The ID code register (SDIDR) is a 32-bit register. In the IDCODE mode, SDIDR can output H'0005200F, which is a fixed code, from TDO. However, no serial data can be written to SDIDR via TDI. For SDIDR, read/write by the CPU cannot be performed.

31	28	27		12	11		1	0	
0000		0001	0000	0101	0010	0000	0000	111	1
Version (4 bits)		Part Number (16 bits)				Manufacture Identify (11 bits)			Fixed Code (1 bit)

18.4 Operation

18.4.1 TAP Controller

Figure 18.2 shows the internal states of TAP controller. State transitions basically conform with the JTAG standard.

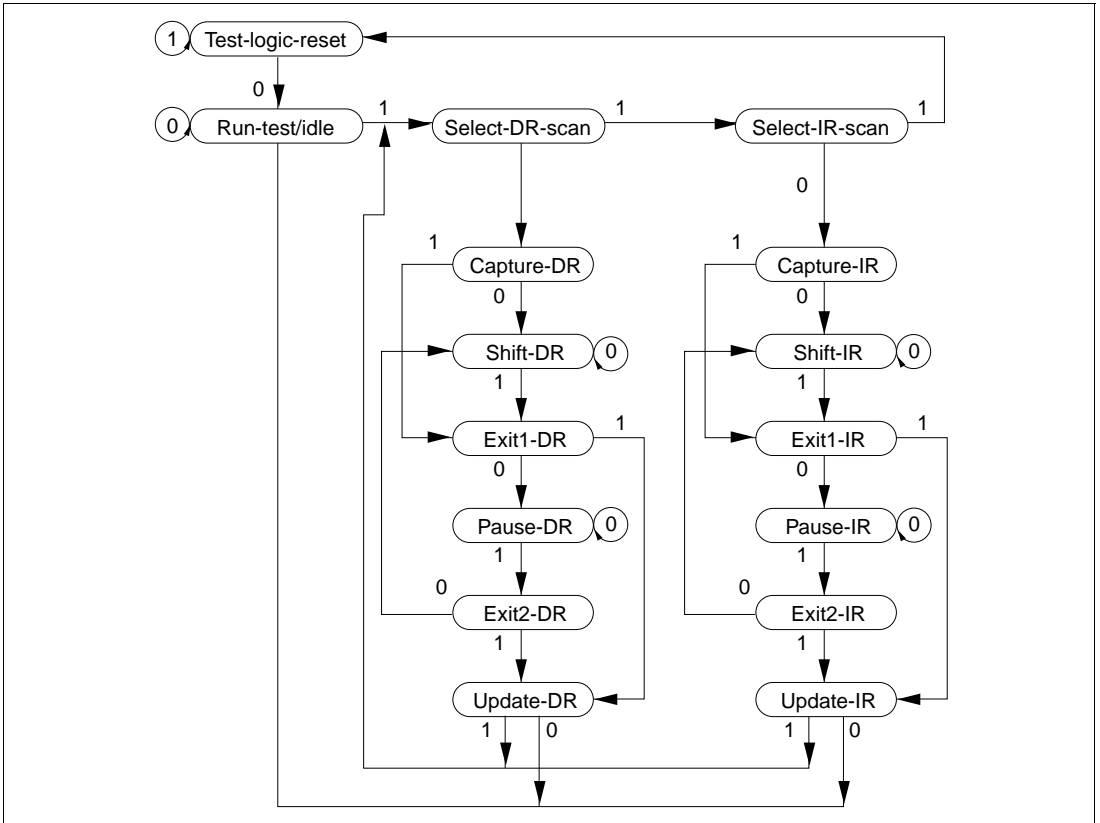

Figure 18.2 TAP Controller State Transitions

18.4.2 H-UDI Interrupt and Serial Transfer

When an H-UDI interrupt instruction is transferred to SDIR via TDI, an interrupt is generated. Data transfer can be controlled by means of the H-UDI interrupt service routine. Transfer can be performed by means of SDDR.

Control of data input/output between an external device and the H-UDI is performed by monitoring the SDTRF bit in SDSR externally and internally. Internal SDTRF bit monitoring is carried out by having SDSR read by the CPU.

The H-UDI interrupt and serial transfer procedure is as follows.

1. An instruction is input to SDIR by serial transfer, and an H-UDI interrupt request is generated.
2. After the H-UDI interrupt request is issued, the SDTRF bit in SDSR is monitored externally. After output of SDTRF = 1 from TDO is observed, serial data is transferred to SDDR.
3. On completion of the serial transfer to SDDR, the SDTRF bit is cleared to 0, and SDDR can be accessed by the CPU. After SDDR has been accessed, SDDR serial transfer is enabled by setting the SDTRF bit to 1 in SDSR.
4. Serial data transfer between an external device and the H-UDI can be carried out by constantly monitoring the SDTRF bit in SDSR externally and internally.

Figures 18.3, 18.4, and 18.5 show the timing of data transfer between an external device and the H-UDI.

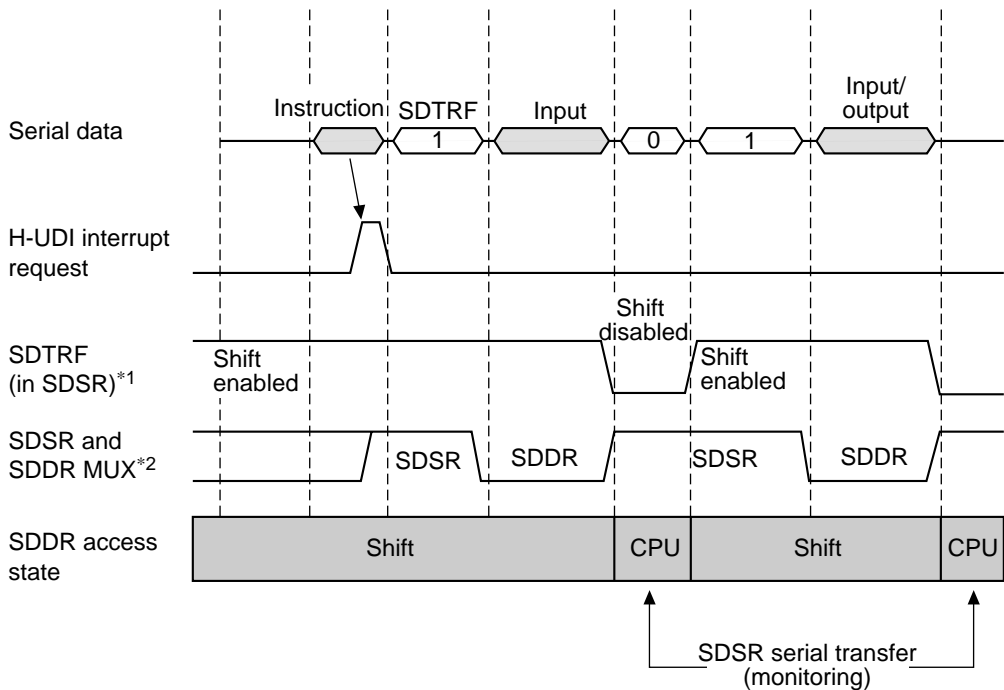

Notes: *1 SDTRF flag (in SDRS): Indicates whether SDDR access by the CPU or serial transfer data input/output to SDDR is possible.

1	SDDR is shift-disabled. SDDR access by the CPU is enabled.
2	SDDR is shift-enabled. Do not access SDDR until SDTRF = 0.

Conditions:

- SDTRF = 1
 - When $\overline{\text{TRST}} = 0$
 - When the CPU writes 1
 - In bypass mode
- SDTRF = 0
 - End of SDDR shift access in serial transfer

*2 SDRS/SDDR (Update-DR state) internal MUX switchover timing

- Switchover from SDRS to SDDR: On completion of serial transfer in which SDTRF = 1 is output from TDO
- Switchover from SDDR to SDRS: On completion of serial transfer to SDDR

Figure 18.3 Data Input/Output Timing Chart (1)

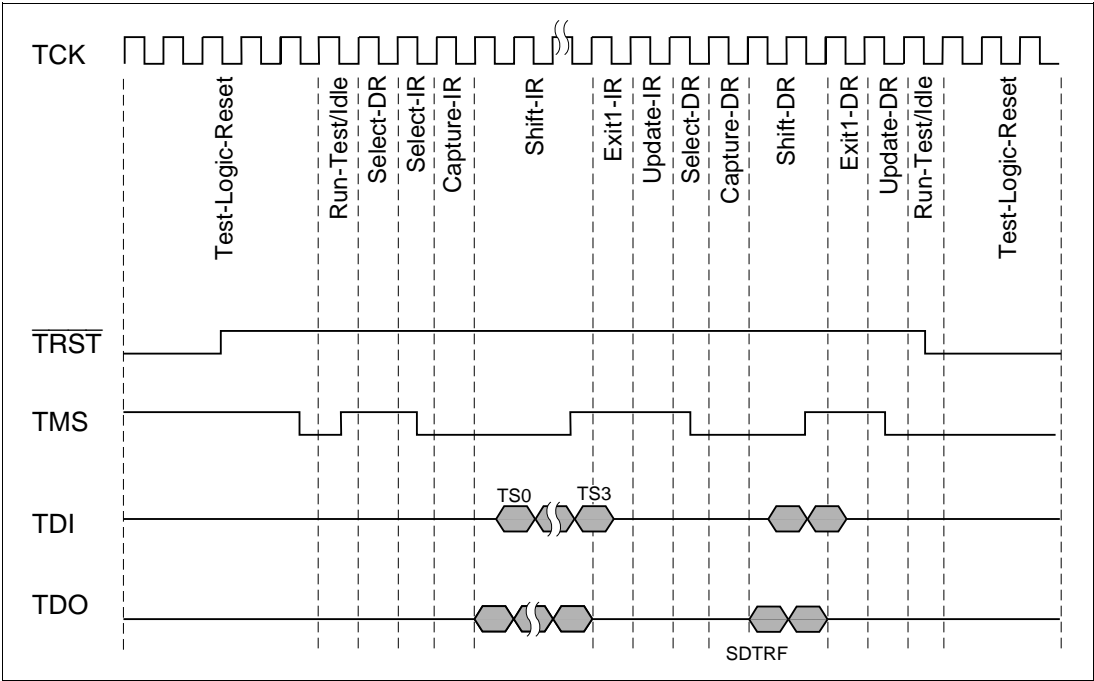

Figure 18.4 Data Input/Output Timing Chart (2)

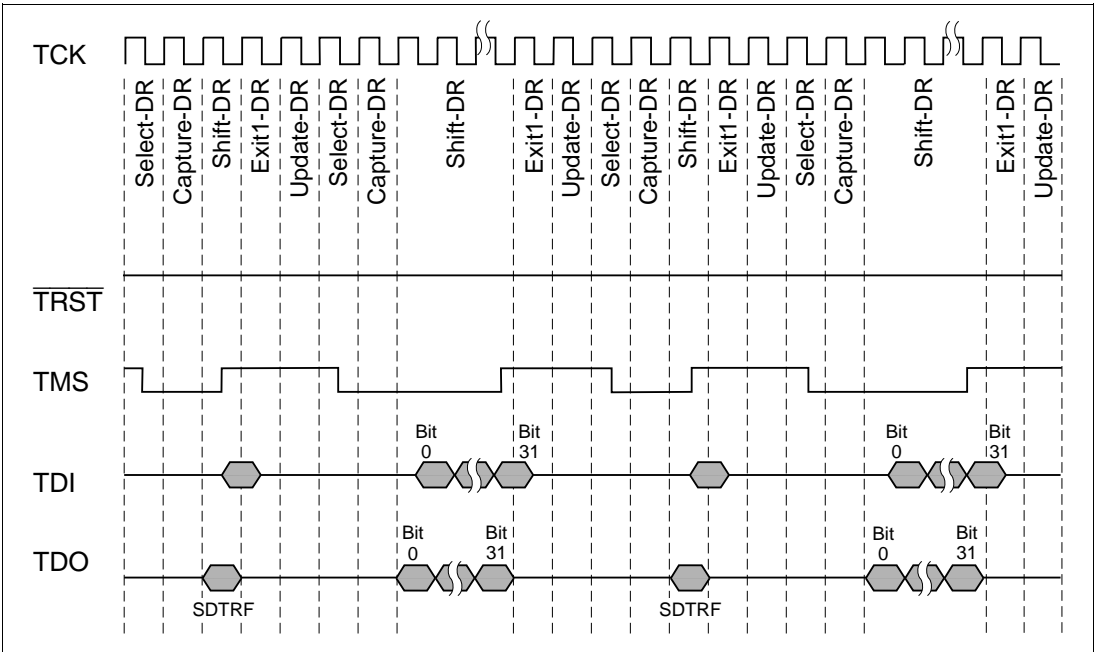

Figure 18.5 Data Input/Output Timing Chart (3)

18.4.3 H-UDI Reset

The H-UDI can be reset in two ways.

- The H-UDI is reset when the $\overline{\text{TRST}}$ signal is held at 0.
- When $\overline{\text{TRST}} = 1$, the H-UDI can be reset by inputting at least five TCK clock cycles while $\text{TMS} = 1$.

18.5 Boundary Scan

The H-UDI pins can be placed in the boundary scan mode stipulated by IEEE1149.1 by setting a command in SDIR.

18.5.1 Supported Instructions

The SH7616 supports the three essential instructions defined in IEEE1149.1 (BYPASS, SAMPLE/PRELOAD, and EXTEST) and optional instructions (CLAMP, HIGHZ, and IDCODE).

BYPASS: The BYPASS instruction is an essential standard instruction that operates the bypass register. This instruction shortens the shift path to speed up serial data transfer involving other chips on the printed circuit board. While this instruction is executing, the test circuit has no effect on the system circuits. The instruction code is 1111.

SAMPLE/PRELOAD: The SAMPLE/PRELOAD instruction inputs values from the SH7616's internal circuitry to the boundary scan register, outputs values from the scan path, and loads data onto the scan path. When this instruction is executing, the SH7616's input pin signals are transmitted directly to the internal circuitry, and internal circuit values are directly output externally from the output pins. The SH7616's system circuits are not affected by execution of this instruction. The instruction code is 0100.

In a SAMPLE operation, a snapshot of a value to be transferred from an input pin to the internal circuitry, or a value to be transferred from the internal circuitry to an output pin, is latched into the boundary scan register and read from the scan path. Snapshot latching is performed in synchronization with the rise of TCK in the Capture-DR state. Snapshot latching does not affect normal operation of the SH7616.

In a PRELOAD operation, an initial value is set in the parallel output latch of the boundary scan register from the scan path prior to the EXTEST instruction. Without a PRELOAD operation, when the EXTEST instruction was executed an undefined value would be output from the output pin until completion of the initial scan sequence (transfer to the output latch) (with the EXTEST instruction, the parallel output latch value is constantly output to the output pin).

EXTEST: This instruction is provided to test external circuitry when the SH7616 is mounted on a printed circuit board. When this instruction is executed, output pins are used to output test data

(previously set by the SAMPLE/PRELOAD instruction) from the boundary scan register to the printed circuit board, and input pins are used to latch test results into the boundary scan register from the printed circuit board. If testing is carried out by using the EXTEST instruction N times, the Nth test data is scanned-in when test data (N-1) is scanned out.

Data loaded into the output pin boundary scan register in the Capture-DR state is not used for external circuit testing (it is replaced by a shift operation).

The instruction code is 0000.

CLAMP: When the CLAMP instruction is enabled, the output pin outputs the value of the boundary scan register that has been set by the SAMPLE/PRELOAD instruction. While the CLAMP instruction is enabled, the state of the boundary scan register maintains the previous state regardless of the state of the TAP controller.

A bypass register is connected between TDI and TDO. The related circuit operates in the same way when the BYPASS instruction is enabled.

The instruction code is 0010.

HIGHZ: When the HIGHZ instruction is enabled, all output pins enter a high-impedance state. While the HIGHZ instruction is enabled, the state of the boundary scan register maintains the previous state regardless of the state of the TAP controller.

A bypass register is connected between TDI and TDO. The related circuit operates in the same way when the BYPASS instruction is enabled.

The instruction code is 0010.

IDCODE: When the IDCODE instruction is enabled, the value of the ID code register is output from TDO with LSB first when the TAP controller is in the Shift-DR state. While this instruction is being executed, the test circuit does not affect the system circuit.

When the TAP controller is in the Test-Logic-Reset state, the instruction register is initialized to the IDCODE instruction.

The instruction code is 0010.

18.5.2 Notes on Use

1. Boundary scan mode does not cover clock-related signals (EXTAL, XTAL, CKIO, CAP1, CAP2).
2. Boundary scan mode does not cover reset-related signals ($\overline{\text{RES}}$, ASEMODE).
3. Boundary scan mode does not cover H-UDI-related signals (TCK, TDI, TDO, TMS, $\overline{\text{TRST}}$).
4. Fix the ASEMODE pin high.

18.6 Usage Notes

- A reset must always be executed by driving the $\overline{\text{TRST}}$ signal to 0, regardless of whether or not the H-UDI is to be activated. $\overline{\text{TRST}}$ must be held low for 20 TCK clock cycles. For details, see section 22, Electrical Characteristics.
- The registers are not initialized in standby mode. If $\overline{\text{TRST}}$ is set to 0 in standby mode, bypass mode will be entered.
- The frequency of TCK must be lower than that of the peripheral module clock (P ϕ). For details, see section 22, Electrical Characteristics.
- In data transfer, data input/output starts with the LSB. Figure 18.6 shows serial data input/output.
- When data that exceeds the number of bits of the register connected between TDI and TDO is serially transferred, the serial data that exceeds the number of register bits and output from TDO is the same as that input from TDI.
- If the H-UDI serial transfer sequence is disrupted, a $\overline{\text{TRST}}$ reset must be executed. Transfer should then be retried, regardless of the transfer operation.
- TDO is output at the falling edge of TCK when one of six instructions defined in IEEE1149.1 is selected. Otherwise, it is output at the rising edge of TCK.

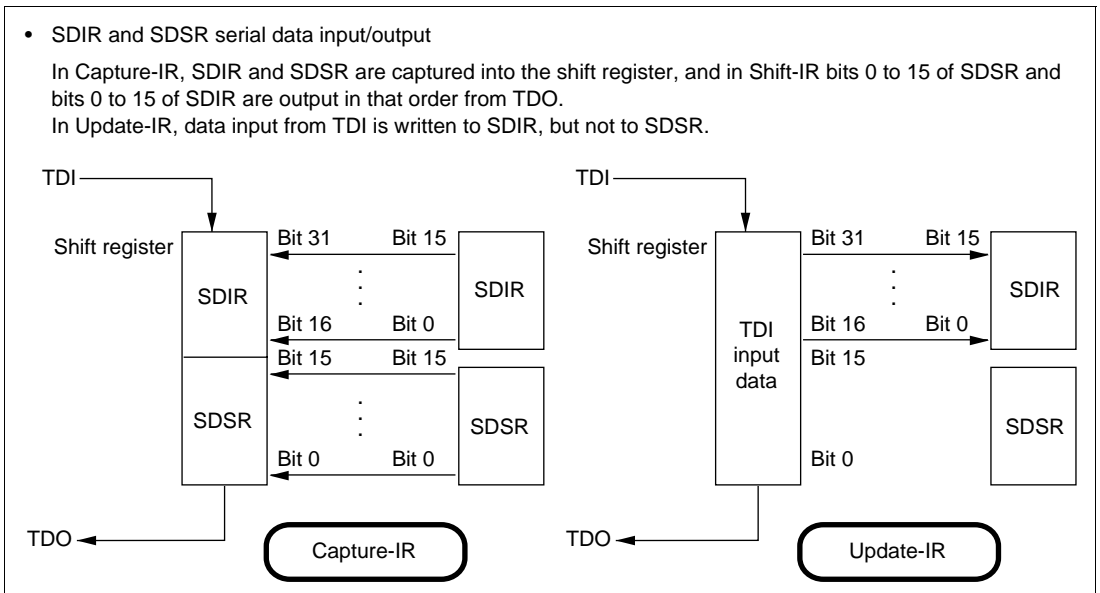
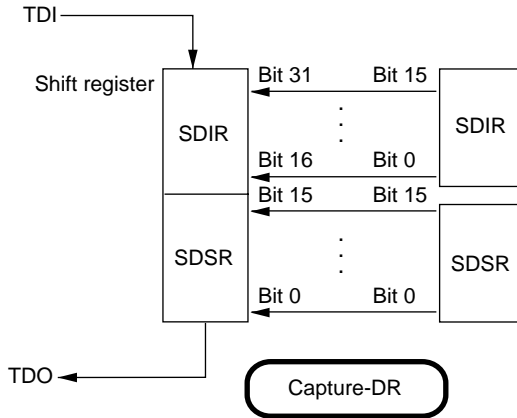

Figure 18.6 Serial Data Input/Output (1)

- SDDRH and SDDRL serial data input/output

- (1) In H-UDI interrupt mode, before $SDTRF = 1$ is read from TDO when an H-UDI interrupt is generated, SDCSR and SDIR are captured into the shift register in Capture-DR, and in Shift-DR bits 0 to 15 of SDCSR and bits 0 to 15 of SDIR are output in that order from TDO. In Update-DR, TDI input data is not written to any register.



- (2) In H-UDI interrupt mode, after $SDTRF = 1$ is read from TDO when an H-UDI interrupt is generated, SDDRH and SDDRL are captured into the shift register in Capture-DR, and in Shift-DR bits 0 to 15 of SDDRL and bits 0 to 15 of SDDRH are output in that order from TDO. Data input from TDI is written to SDDRH and SDDRL in Update-DR.

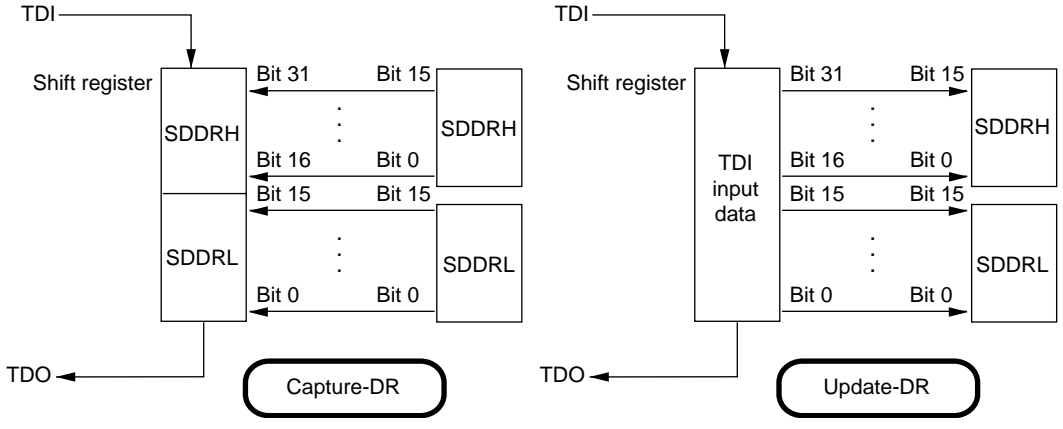

Figure 18.6 Serial Data Input/Output (2)

- SDIDR serial data input/output

In IDCODE mode, SDIDR is captured into the shift register in Capture-DR, and in Shift-DR bits 0 to 31 of SDIDR are output in that order from TDO.

In Update-DR, data input from TDI is not written to any register.

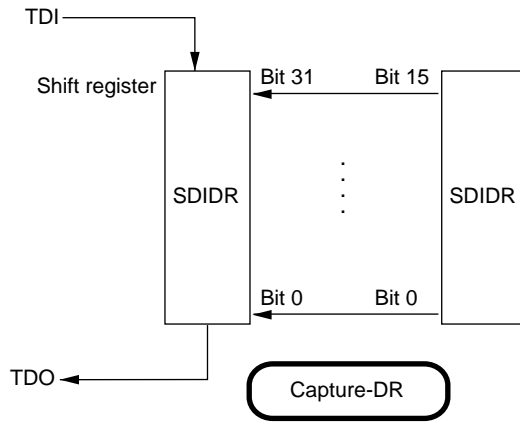

Figure 18.6 Serial Data Input/Output (3)

Section 19 Pin Function Controller (PFC)

19.1 Overview

The pin function controller (PFC) consists of registers to select multiplexed pin functions and input/output direction. The pin function and input/output direction can be selected for individual pins regardless of the operating mode of the chip. Table 19.1 shows the chip's multiplex pins.

Table 19.1 Multiplex Pins

Port	Function 1 [00]*			Function 2 [01]*			Function 3 [10]*			Function 4 [11]*		
	Signal Name	I/O	Related Module	Signal Name	I/O	Related Module	Signal Name	I/O	Related Module	Signal Name	I/O	Related Module
A	PA13	I/O	Port	SRCK0	I	SIO0	—	—	—	—	—	—
A	PA12	I/O	Port	SRS0	I	SIO0	—	—	—	—	—	—
A	PA11	I/O	Port	SRXD0	I	SIO0	—	—	—	—	—	—
A	PA10	I/O	Port	STCK0	I	SIO0	—	—	—	—	—	—
A	PA9	I/O	Port	STS0	I/O	SIO0	—	—	—	—	—	—
A	PA8	I/O	Port	STXD0	O	SIO0	—	—	—	—	—	—
A	WDTOV \overline{F}	O	WDT	PA7	I/O	Port	—	—	—	—	—	—
A	PA6	I/O	Port	FTCI	I	FRT	—	—	—	—	—	—
A	PA5	I/O	Port	FTI	I	FRT	—	—	—	—	—	—
A	PA4	I/O	Port	FTOA	O	FRT	—	—	—	—	—	—
A	CKPO	O	Port	FTOB	O	FRT	—	—	—	—	—	—
A	PA2	I/O	Port	LNKSTA	I	EtherC	—	—	—	—	—	—
A	PA1	I/O	Port	EXOUT	O	EtherC	—	—	—	—	—	—
A	PA0	I/O	Port	CAMSEN	I	EtherC	—	—	—	—	—	—
B	PB15	I/O	Port	—	—	—	SCK1	I/O	SCIF1	—	—	—
B	PB14	I/O	Port	—	—	—	RXD1	I	SCIF1	—	—	—
B	PB13	I/O	Port	—	—	—	TXD1	O	SCIF1	—	—	—
B	PB12	I/O	Port	SRCK2	I	SIO2	RTS	O	SCIF1	STATS1	O	BSC
B	PB11	I/O	Port	SRS2	I	SIO2	CTS	I	SCIF1	STATS0	O	BSC
B	PB10	I/O	Port	SRXD2	I	SIO2	TIOCA1	I/O	TPU1	—	—	—
B	PB9	I/O	Port	STCK2	I	SIO2	TIOCB1	I/O	TPU1	—	—	—
B	PB8	I/O	Port	STS2	I/O	SIO2	TIOCA2	I/O	TPU2	—	—	—
B	PB7	I/O	Port	STXD2	O	SIO2	TIOCB2	I/O	TPU2	—	—	—
B	PB6	I/O	Port	SRCK1	I	SIO1	SCK2	I/O	SCIF2	—	—	—
B	PB5	I/O	Port	SRS1	I	SIO1	RXD2	I	SCIF2	—	—	—
B	PB4	I/O	Port	SRXD1	I	SIO1	TXD2	O	SCIF2	—	—	—
B	PB3	I/O	Port	STCK1	I	SIO1	TIOCA0	I/O	TPU2	—	—	—
B	PB2	I/O	Port	STS1	I/O	SIO1	TIOCB0	I/O	TPU2	—	—	—
B	PB1	I/O	Port	STXD1	O	SIO1	TIOCC0	I/O	TPU2	—	—	—
B	PB0	I/O	Port	—	—	—	TIOCD0	I/O	TPU2	WOL	O	EtherC

Notes: In the initial state, function 1 is selected.

* The initial value is "input."

The figures in brackets indicate the settings of the mode bits (MD1, MD0) in the PFC to select multiplexed functions in port A[0:13] and port B[0:15].

19.2 Register Configuration

Table 19.2 shows the PFC registers.

Table 19.2 Register Configuration

Name	Abbreviation	R/W	Initial Value	Address	Access Size
Port A control register	PACR	R/W	H'0000	H'FFFFFFC80	8, 16
Port A I/O register	PAIOR	R/W	H'0000	H'FFFFFFC82	8, 16
Port B control register	PBCR	R/W	H'0000	H'FFFFFFC88	8, 16
Port B I/O register	PBIOR	R/W	H'0000	H'FFFFFFC8A	8, 16
Port B control register 2	PBCR2	R/W	H'0000	H'FFFFFFC8E	8, 16

19.3 Register Descriptions

19.3.1 Port A Control Register (PACR)

Bit:	15	14	13	12	11	10	9	8
	—	—	PA13MD	PA12MD	PA11MD	PA10MD	PA9MD	PA8MD
Initial value:	0	0	0	0	0	0	0	0
R/W:	R	R	R/W	R/W	R/W	R/W	R/W	R/W
Bit:	7	6	5	4	3	2	1	0
	PA7MD	PA6MD	PA5MD	PA4MD	PA3MD	PA2MD	PA1MD	PA0MD
Initial value:	0	0	0	0	0	0	0	0
R/W:	R/W	R/W	R/W	R/W	R/W	R/W	R/W	R/W

The port A control register (PACR) is a 16-bit read/write register that selects the functions of the 14 multiplex pins in port A.

PACR is initialized to H'0000 by a power-on reset. It is not initialized by a manual reset or in standby mode or sleep mode.

Bits 15 and 14—Reserved: These bits are always read as 0. The write value should always be 0.

Bit 13—PA13 Mode Bit (PA13MD): Selects the function of pin PA13/SRCK0.

Bit 13: PA13MD	Description
0	General input/output (PA13) (Initial value)
1	SIOF serial receive clock input (SRCK0)

Bit 12—PA12 Mode Bit (PA12MD): Selects the function of pin PA12/SRS0.

Bit 12: PA12MD	Description
0	General input/output (PA12) (Initial value)
1	SIOF serial receive synchronous input (SRS0)

Bit 11—PA11 Mode Bit (PA11MD): Selects the function of pin PA11/SRXD0.

Bit 11: PA11MD	Description
0	General input/output (PA11) (Initial value)
1	SIOF serial receive data (SRXD0)

Bit 10—PA10 Mode Bit (PA10MD): Selects the function of pin PA10/STCK0.

Bit 10: PA10MD	Description
0	General input/output (PA10) (Initial value)
1	SIOF serial transmit clock (STCK0)

Bit 9—PA9 Mode Bit (PA9MD): Selects the function of pin PA9/STS0.

Bit 9: PA9MD	Description
0	General input/output (PA9) (Initial value)
1	SIOF serial transmit synchronous input/output (STS0)

Bit 8—PA8 Mode Bit (PA8MD): Selects the function of pin PA8/STXD0.

Bit 8: PA8MD	Description
0	General input/output (PA8) (Initial value)
1	SIOF serial transmit data output (STXD0)

Bit 7—PA7 Mode Bit (PA7MD): Selects the function of pin $\overline{\text{WDTOVF}}$ /PA7.

Bit 7: PA7MD	Description
0	WDT overflow signal output ($\overline{\text{WDTOVF}}$)* (Initial value)
1	General input/output (PA7)

Note: * $\overline{\text{WDTOVF}}$ is an output pin after a reset, so care is required when using this pin as a general input port (PA7).

Bit 6—PA6 Mode Bit (PA6MD): Selects the function of pin PA6/FTCI.

Bit 6: PA6MD	Description
0	General input/output (PA6) (Initial value)
1	FRT clock input (FTCI)

Bit 5—PA5 Mode Bit (PA5MD): Selects the function of pin PA5/FTI.

Bit 5: PA5MD	Description
0	General input/output (PA5) (Initial value)
1	FRT input capture input (FTI)

Bit 4—PA4 Mode Bit (PA4MD): Selects the function of pin PA4/FTO4.

Bit 4: PA4MD	Description
0	General input/output (PA4) (Initial value)
1	FRT output compare output (FTOA)

Bit 3—PA3 Mode Bit (PA3MD): Selects the function of pin CKPO/FTOB.

Bit 3: PA3MD	Description
0	Peripheral module clock output (CKPO) (Initial value)
1	FRT output compare output (FTOB)

Bit 2—PA2 Mode Bit (PA2MD): Selects the function of pin PA2/LNKSTA.

Bit 2: PA2MD	Description
0	General input/output (PA2) (Initial value)
1	EtherC link status input (LNKSTA)

Bit 1—PA1 Mode Bit (PA1MD): Selects the function of pin PA1/EXOUT.

Bit 1: PA1MD	Description
0	General input/output (PA1) (Initial value)
1	EtherC general external output (EXOUT)

Bit 0—PA0 Mode Bit (PA0MD): Selects the function of pin PA0.

Bit 0: PA0MD	Description
0	General input/output (PA0) (Initial value)
1	EtherC CAM sense input (CAMSEN)

19.3.2 Port A I/O Register (PAIOR)

Bit:	15	14	13	12	11	10	9	8
	—	—	PA13IOR	PA12IOR	PA11IOR	PA10IOR	PA9IOR	PA8IOR
Initial value:	0	0	0	0	0	0	0	0
R/W:	R	R	R/W	R/W	R/W	R/W	R/W	R/W

Bit:	7	6	5	4	3	2	1	0
	PA7IOR	PA6IOR	PA5IOR	PA4IOR	—	PA2IOR	PA1IOR	PA0IOR
Initial value:	0	0	0	0	0	0	0	0
R/W:	R/W	R/W	R/W	R/W	R	R/W	R/W	R/W

The port A I/O register (PAIOR) is a 16-bit read/write register that selects the input/output direction of the 14 multiplex pins in port A. Bits PA13IOR to PA4IOR and PA2IOR to PA0IOR correspond to individual pins in port A. PAIOR is enabled when port A pins function as general input pins (PA13 to PA4 and PA2 to PA0), and disabled otherwise. When port A pins function as PA13 to PA4 and PA2 to PA0, a pin becomes an output when the corresponding bit in PAIOR is set to 1, and an input when the bit is cleared to 0.

PAIOR is initialized to H'0000 by a power-on reset. It is not initialized by a manual reset or in standby mode or sleep mode.

19.3.3 Port B Control Registers (PBCR, PBCR2)

The port B control registers (PBCR and PBCR2) are 16-bit read/write registers that select the functions of the 16 multiplex pins in port B. PBCR selects the functions of the pins for the upper 8 bits in port B, and PBCR2 selects the functions of the pins for the lower 8 bits in port B.

PBCR and PBCR2 are initialized to H'0000 by a power-on reset. They are not initialized by a manual reset or in standby mode or sleep mode.

Port B Control Register (PBCR)

Bit:	15	14	13	12	11	10	9	8
	PB15 MD1	PB15 MD0	PB14 MD1	PB14 MD0	PB13 MD1	PB13 MD0	PB12 MD1	PB12 MD0
Initial value:	0	0	0	0	0	0	0	0
R/W:	R/W	R/W	R/W	R/W	R/W	R/W	R/W	R/W
Bit:	7	6	5	4	3	2	1	0
	PB11 MD1	PB11 MD0	PB10 MD1	PB10 MD0	PB9 MD1	PB9 MD0	PB8 MD1	PB8 MD0
Initial value:	0	0	0	0	0	0	0	0
R/W:	R/W	R/W	R/W	R/W	R/W	R/W	R/W	R/W

Bits 15 and 14—PB15 Mode Bits 1 and 0 (PB15MD1, PB15MD0): These bits select the function of pin PB15/SCK1.

Bit 15: PB15MD1	Bit 14: PB15MD0	Description
0	0	General input/output (PB15) (Initial value)
	1	Reserved
1	0	SCIF1 serial clock input/output (SCK1)
	1	Reserved

Bits 13 and 12—PB14 Mode Bits 1 and 0 (PB14MD1, PB14MD0): These bits select the function of pin PB14/RXD1.

Bit 13: PB14MD1	Bit 12: PB14MD0	Description
0	0	General input/output (PB14) (Initial value)
	1	Reserved
1	0	SCIF1 serial data input (RXD1)
	1	Reserved

Bits 11 and 10—PB13 Mode Bits 1 and 0 (PB13MD1, PB13MD0): These bits select the function of pin PB13/TXD1.

Bit 11: PB13MD1	Bit 10: PB13MD0	Description
0	0	General input/output (PB13) (Initial value)
	1	Reserved
1	0	SCIF1 serial data output (TXD1)
	1	Reserved

Bits 9 and 8—PB12 Mode Bits 1 and 0 (PB12MD1, PB12MD0): These bits select the function of pin PB12/SRCK2/ $\overline{\text{RTS}}$ /STATS1.

Bit 9: PB12MD1	Bit 8: PB12MD0	Description
0	0	General input/output (PB12) (Initial value)
	1	SIO2 serial receive clock input (SRCK2)
1	0	SCIF1 transmit request ($\overline{\text{RTS}}$)
	1	BSC status 1 output (STATS1)

Bits 7 and 6—PB11 Mode Bits 1 and 0 (PB11MD1, PB11MD0): These bits select the function of pin PB11/SRS2/ $\overline{\text{CTS}}$ /STATS0.

Bit 7: PB11MD1	Bit 6: PB11MD0	Description
0	0	General input/output (PB11) (Initial value)
	1	SIO2 serial receive synchronous input (SRS2)
1	0	SCIF1 transmit permission ($\overline{\text{CTS}}$)
	1	BSC status 0 output (STATS0)

Bits 5 and 4—PB10 Mode Bits 1 and 0 (PB10MD1, PB10MD0): These bits select the function of pin PB10/SRXD2/TIOCA1.

Bit 5: PB10MD1	Bit 4: PB10MD0	Description
0	0	General input/output (PB10) (Initial value)
	1	SIO2 serial receive data input (SRXD2)
1	0	TPU1 input capture input/output compare output (TIOCA1)
	1	Reserved

Bits 3 and 2—PB9 Mode Bits 1 and 0 (PB9MD1, PB9MD0): These bits select the function of pin PB9/STCK2/TIOCB1, TCLKC.

Bit 3: PB9MD1	Bit 2: PB9MD0	Description
0	0	General input/output (PB9) (Initial value)
	1	SIO2 serial transmit clock input (STCK2)
1	0	TPU1 input capture input/output compare output (TIOCB1)*
	1	Reserved

Note: * Timer clock input C (TCLKC) is selected when the TPU phase counting mode is set, or according to the setting of bits TPSC2 to TPSC0 in TCR.

Bits 1 and 0—PB8 Mode Bits 1 and 0 (PB8MD1, PB8MD0): These bits select the function of pin PB8/STS2/TIOCA2.

Bit 1: PB8MD1	Bit 0: PB8MD0	Description
0	0	General input/output (PB8) (Initial value)
	1	SIO2 serial transmit synchronous input/output (STS2)
1	0	TPU2 input capture input/output compare output (TIOCA2)
	1	Reserved

Port B Control Register 2 (PBCR2)

Bit:	15	14	13	12	11	10	9	8
	PB7 MD1	PB7 MD0	PB6 MD1	PB6 MD0	PB5 MD1	PB5 MD0	PB4 MD1	PB4 MD0
Initial value:	0	0	0	0	0	0	0	0
R/W:	R/W	R/W	R/W	R/W	R/W	R/W	R/W	R/W
Bit:	7	6	5	4	3	2	1	0
	PB3 MD1	PB3 MD0	PB2 MD1	PB2 MD0	PB1 MD1	PB1 MD0	PB0 MD1	PB0 MD0
Initial value:	0	0	0	0	0	0	0	0
R/W:	R/W	R/W	R/W	R/W	R/W	R/W	R/W	R/W

Bits 15 and 14—PB7 Mode Bits 1 and 0 (PB7MD1, PB7MD0): These bits select the function of pin PB7/STXD2/TIOCB2, TCLKD.

Bit 15: PB7MD1	Bit 14: PB7MD0	Description
0	0	General input/output (PB7) (Initial value)
	1	SIO2 serial transmit data output (STXD2)
1	0	TPU2 input capture input/output compare output (TIOCB2)*
	1	Reserved

Note: * Timer clock input D (TCLKD) is selected when the TPU phase counting mode is set, or according to the setting of bits TPSC2 to TPSC0 in TCR.

Bits 13 and 12—PB6 Mode Bits 1 and 0 (PB6MD1, PB6MD0): These bits select the function of pin PB6/SRCK1/SCK2.

Bit 13: PB6MD1	Bit 12: PB6MD0	Description
0	0	General input/output (PB6) (Initial value)
	1	SIO1 serial receive clock input (SRCK1)
1	0	SCIF2 serial clock input/output (SCK2)
	1	Reserved

Bits 11 and 10—PB5 Mode Bits 1 and 0 (PB5MD1, PB5MD0): These bits select the function of pin PB5/SRS1/RXD2.

Bit 11: PB5MD1	Bit 10: PB5MD0	Description
0	0	General input/output (PB5) (Initial value)
	1	SIO1 serial receive synchronous input (SRS1)
1	0	SCIF2 serial data input (RXD2)
	1	Reserved

Bits 9 and 8—PB4 Mode Bits 1 and 0 (PB4MD1, PB4MD0): These bits select the function of pin PB4/SRXD1/TXD2.

Bit 9: PB4MD1	Bit 8: PB4MD0	Description
0	0	General input/output (PB4) (Initial value)
	1	SIO1 serial receive data input (SRXD1)
1	0	SCIF2 serial data output (TXD2)
	1	Reserved

Bits 7 and 6—PB3 Mode Bits 1 and 0 (PB3MD1, PB3MD0): These bits select the function of pin PB3/STCK1/TIOCA0.

Bit 7: PB3MD1	Bit 6: PB3MD0	Description
0	0	General input/output (PB3) (Initial value)
	1	SIO1 serial transmit clock input (STCK1)
1	0	TPU0 input capture input/output compare output (TIOCA0)
	1	Reserved

Bits 5 and 4—PB2 Mode Bits 1 and 0 (PB2MD1, PB2MD0): These bits select the function of pin PB2/STS1/TIOCB0.

Bit 5: PB2MD1	Bit 4: PB2MD0	Description
0	0	General input/output (PB2) (Initial value)
	1	SIO1 serial transmit synchronous input/output (STS1)
1	0	TPU0 input capture input/output compare output (TIOCB0)
	1	Reserved

Bits 3 and 2—PB1 Mode Bits 1 and 0 (PB1MD1, PB1MD0): These bits select the function of pin PB1/STXD1/TIOCC0/TCLKA.

Bit 3: PB1MD1	Bit 2: PB1MD0	Description
0	0	General input/output (PB1) (Initial value)
	1	SIO1 serial transmit data output (STXD1)
1	0	TPU0 input capture input/output compare output (TIOCC0)*
	1	Reserved

Note: * Timer clock input A (TCLKA) is selected when the TPU phase counting mode is set, or according to the setting of bits TPSC2 to TPSC0 in TCR.

Bits 1 and 0—PB0 Mode Bits 1 and 0 (PB0MD1, PB0MD0): These bits select the function of pin PB0/TIOCD0/TCLKB.

Bit 1: PB0MD1	Bit 0: PB0MD0	Description
0	0	General input/output (PB0) (Initial value)
	1	Reserved
1	0	TPU0 input capture input/output compare output (TIOCD0)*
	1	EtherC Wake-On-LAN output (WOL)

Note: * Timer clock input B (TCLKB) is selected when the TPU phase counting mode is set, or according to the setting of bits TPSC2 to TPSC0 in TCR.

19.3.4 Port B I/O Register (PBIOR)

Bit:	15	14	13	12	11	10	9	8
	PB15 IOR	PB14 IOR	PB13 IOR	PB12 IOR	PB11 IOR	PB10 IOR	PB9 IOR	PB8 IOR
Initial value:	0	0	0	0	0	0	0	0
R/W:	R/W	R/W	R/W	R/W	R/W	R/W	R/W	R/W
Bit:	7	6	5	4	3	2	1	0
	PB7 IOR	PB6 IOR	PB5 IOR	PB4 IOR	PB3 IOR	PB2 IOR	PB1 IOR	PB0 IOR
Initial value:	0	0	0	0	0	0	0	0
R/W:	R/W	R/W	R/W	R/W	R/W	R/W	R/W	R/W

The port B I/O register (PBIOR) is a 16-bit read/write register that selects the input/output direction of the 16 multiplex pins in port B. Bits PB15IOR to PB0IOR correspond to individual pins in port B. PBIOR is enabled when port B pins function as general input pins (PB15 to PB0), and disabled otherwise. When port B pins function as PB15 to PB0, a pin becomes an output when the corresponding bit in PBIOR is set to 1, and an input when the bit is cleared to 0.

PBIOR is initialized to H'0000 by a power-on reset. It is not initialized by a manual reset or in standby mode or sleep mode.

Section 20 I/O Ports

20.1 Overview

This chip has two ports, designated A and B. Port A is a 14-bit input/output port, and port B is a 16-bit input/output port. The port pins are multiplexed as general input/output and other functions. (The function of multiplexed multiplex pins is selected by means of the pin function controller (PFC).) Ports A and B are each provided with a data register for storing pin data.

20.2 Port A

Port A is an input/output port with the 14 pins shown in figure 20.1. Of the 14 pins, the CKPO pin has no port data register bit, and is multiplexed as an internal clock pin.

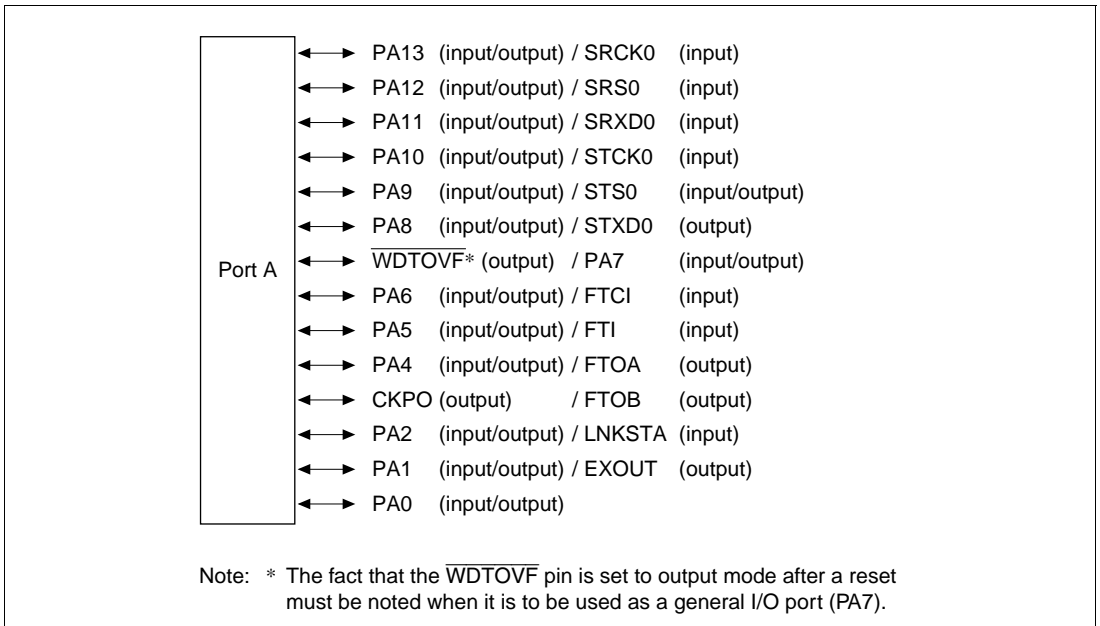

Figure 20.1 Port A

20.2.1 Register Configuration

The port A register is shown in table 20.1.

Table 20.1 Register Configuration

Name	Abbreviation	R/W	Initial Value	Address	Access Size
Port A data register	PADR	R/W	H'0000	H'FFFFFFC84	8, 16

20.2.2 Port A Data Register (PADR)

Bit:	15	14	13	12	11	10	9	8
	—	—	PA13DR	PA12DR	PA11DR	PA10DR	PA9DR	PA8DR
Initial value:	0	0	0	0	0	0	0	0
R/W:	R	R	R/W	R/W	R/W	R/W	R/W	R/W
Bit:	7	6	5	4	3	2	1	0
	PA7DR	PA6DR	PA5DR	PA4DR	—	PA2DR	PA1DR	PA0DR
Initial value:	0	0	0	0	0	0	0	0
R/W:	R/W	R/W	R/W	R/W	R	R/W	R/W	R/W

The port A data register (PADR) is a 16-bit read/write register that stores port A data. Bits 15, 14, and 3 are reserved: they always read 0, and the write value should always be 0. Bits PA13DR to PA0DR correspond to pins PA13 to PA0. When a pin functions as a general output, if a value is written to PADR, that value is output directly from the pin, and if PADR is read, the register value is returned directly regardless of the pin state. When a pin functions as a general input, if PADR is read the pin state, not the register value, is returned directly. If a value is written to PADR, although that value is written into PADR it does not affect the pin state. Table 20.2 summarizes port A data register read/write operations.

PADR is initialized to H'0000 by a power-on reset. It is not initialized by a manual reset or in standby mode or sleep mode.

Table 20.2 Port A Data Register (PADR) Read/Write Operations

PAIOR	Pin Function	Read	Write
0	General input	Pin state	Value is written to PADR, but does not affect pin state
	Other than general input	Pin state	Value is written to PADR, but does not affect pin state
1	General output	PADR value	Write value is output from pin
	Other than general output	PADR value	Value is written to PADR, but does not affect pin state

20.3 Port B

Port B is an input/output port with the 16 pins shown in figure 20.2.

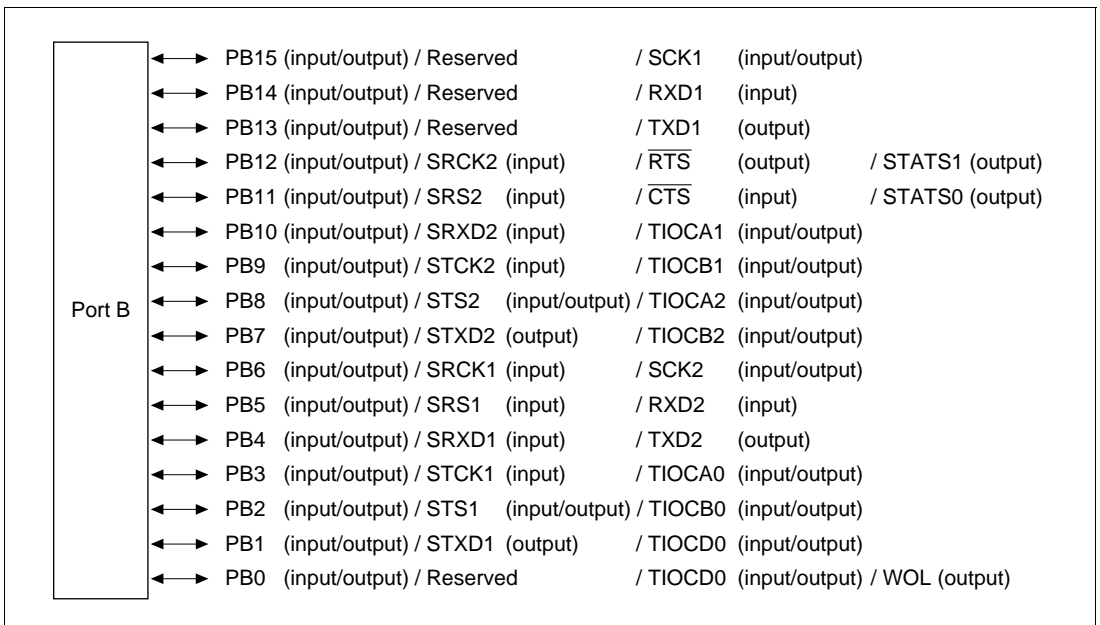

Figure 20.2 Port B

20.3.1 Register Configuration

Table 20.3 shows the port B register.

Table 20.3 Register Configuration

Name	Abbreviation	R/W	Initial Value	Address	Access Size
Port B data register	PBDR	R/W	H'0000	H'FFFFFFC8C	8, 16

20.3.2 Port B Data Register (PBDR)

Bit:	15	14	13	12	11	10	9	8
	PB15DR	PB14DR	PB13DR	PB12DR	PB11DR	PB10DR	PB9DR	PB8DR
Initial value:	0	0	0	0	0	0	0	0
R/W:	R/W	R/W	R/W	R/W	R/W	R/W	R/W	R/W
Bit:	7	6	5	4	3	2	1	0
	PB7DR	PB6DR	PB5DR	PB4DR	PB3DR	PB2DR	PB1DR	PB0DR
Initial value:	0	0	0	0	0	0	0	0
R/W:	R/W	R/W	R/W	R/W	R/W	R/W	R/W	R/W

The port B data register (PBDR) is a 16-bit read/write register that stores port B data. Bits PB15DR to PB0DR correspond to pins PB15 to PB0. When a pin functions as a general output, if a value is written to PBDR, that value is output directly from the pin, and if PBDR is read, the register value is returned directly regardless of the pin state. When a pin functions as a general input, if PBDR is read the pin state, not the register value, is returned directly. If a value is written to PBDR, although that value is written into PBDR it does not affect the pin state. Table 20.4 shows port B data register read/write operations.

PBDR is initialized to H'0000 by a power-on reset. It is not initialized by a manual reset or in standby mode or sleep mode.

Table 20.4 Port B Data Register (PBDR) Read/Write Operations

PBIOR	Pin Function	Read	Write
0	General input	Pin state	Value is written to PBDR, but does not affect pin state
	Other than general input	Pin state	Value is written to PBDR, but does not affect pin state
1	General output	PBDR value	Write value is output from pin
	Other than general output	PBDR value	Value is written to PBDR, but does not affect pin state

Section 21 Power-Down Modes

21.1 Overview

This chip has a module standby function (which reduces power consumption by selectively halting operation of unnecessary modules among the on-chip peripheral modules and the DSP unit), a sleep mode (which halts CPU functions), and a standby mode (which halts all functions).

21.1.1 Power-Down Modes

The following modes and function are provided as power-down modes:

1. Sleep mode
2. Standby mode
3. Module standby function
(UBC, DMAC, DSP, FRT, SCIF1–2, TPU, SIOF, SIO1–2)

Table 21.1 shows the transition conditions for entering the modes from the program execution state, as well as the CPU and peripheral module states in each mode and the procedures for canceling each mode.

Table 21.1 Power-Down Modes

Mode	Transition Condition	State						Canceling Procedure
		On-Chip Oscillation Circuit, E-DMAC, EtherC	CPU, Cache	DSP	BSC	UBC, DMAC, FRT, SCIF1–2, TPU, SIOF, SIO1–2	Pins	
Sleep mode	SLEEP instruction executed with SBY bit set to 0 in SBYCR1	Runs	Halted	Halted	Runs	Runs	Runs	<ol style="list-style-type: none"> 1. Interrupt 2. DMA address error 3. Power-on reset 4. Manual reset
Standby mode	SLEEP instruction executed with SBY bit set to 1 in SBYCR1	Halted	Halted	Halted	Halted, and register values held	UBC: Halted, and register values held Other than UBC: Halted	Held or high impedance	<ol style="list-style-type: none"> 1. NMI interrupt 2. Power-on reset 3. Manual reset
Module standby function	MSTP bit for relevant module is set to 1	Runs	Runs	When MSTP is 1, the clock supply is halted	Runs	When an MSTP bit is 1, the clock supply to the relevant module is halted	FRT, and SCIF1, 2 pins are initialized, and others operate	<ol style="list-style-type: none"> 1. Clear MSTP bit to 0 2. Power-on reset 3. Manual reset

21.1.2 Register

Table 21.2 shows the register configuration.

Table 21.2 Register Configuration

Name	Abbreviation	R/W	Initial Value	Address	Access Size
Standby control register 1	SBYCR1	R/W	H'00	H'FFFFFFE91	8
Standby control register 2	SBYCR2	R/W	H'00	H'FFFFFFE93	8

21.2 Register Descriptions

21.2.1 Standby Control Register 1 (SBYCR1)

Bit:	7	6	5	4	3	2	1	0
	SBY	HIZ	MSTP5 (UBC)	MSTP4 (DMAC)	MSTP3 (DSP)	—	MSTP1 (FRT)	—
Initial value:	0	0	0	0	0	0	0	0
R/W:	R/W	R/W	R/W	R/W	R/W	R	R/W	R

Standby control register 1 (SBYCR1) is an 8-bit read/write register that sets the power-down mode. SBYCR is initialized to H'00 by a reset.

Bit 7—Standby (SBY): Specifies transition to standby mode. To enter the standby mode, halt the WDT (set the TME bit in WTCSR to 0) and set the SBY bit.

Bit 7: SBY Description

0	Executing a SLEEP instruction puts the chip into sleep mode	(Initial value)
1	Executing a SLEEP instruction puts the chip into standby mode	

Bit 6—Port High Impedance (HIZ): Selects whether output pins are set to high impedance or retain the output state in standby mode. When HIZ = 0 (initial state), the specified pin retains its output state. When HIZ = 1, the pin goes to the high-impedance state. See Appendix B.1, Pin States during Resets, Power-Down States and Bus Release State, for which pins are controlled.

Bit 6: HIZ Description

0	Pin state retained in standby mode	(Initial value)
1	Pin goes to high impedance in standby mode	

Bit 5—Module Stop 5 (MSTP5): Specifies halting the clock supply to the user break controller (UBC). When the MSTP5 bit is set to 1, the supply of the clock to the UBC is halted. When the clock halts, the UBC registers retain their pre-halt state. Do not set this bit while the UBC is running.

Bit 5: MSTP5 Description

0	UBC running	(Initial value)
1	Clock supply to UBC halted	

Bit 4—Module Stop 4 (MSTP4): Specifies halting the clock supply to the DMAC. When MSTP4 bit is set to 1, the supply of the clock to the DMAC is halted. When the clock halts, the DMAC retains its pre-halt state. When MSTP4 is cleared to 0 and the DMAC begins running again, it starts operating from its pre-halt state. Set this bit while the DMAC is halted; this bit cannot be set while the DMAC is operating (transferring data).

Bit 4: MSTP4	Description	
0	DMAC running	(Initial value)
1	Clock supply to DMAC halted	

Bit 3—Module Stop 3 (MSTP3): Specifies halting the clock supply to the DSP unit. When the MSTP3 bit is set to 1, the supply of the clock to the DSP unit is halted. When the clock halts, the operation result prior to the halt is retained. This bit should be set when the DSP unit is halted. When the DSP unit is halted, no instructions with a DSP register, MACH, or MACL as an operand can be used.

Bit 3: MSTP3	Description	
0	DSP running	(Initial value)
1	Clock supply to DSP halted	

Bit 2—Reserved: This bit is always read as 0. The write value should always be 0.

Bit 1—Module Stop 1 (MSTP1): Specifies halting the clock supply to the 16-bit free-running timer (FRT). When the MSTP1 bit is set to 1, the supply of the clock to the FRT is halted. When the clock halts, all FRT registers are initialized except the FRT interrupt vector register in INTC, which holds its previous value. When MSTP1 is cleared to 0 and the FRT begins running again, it starts operating from its initial state.

Bit 1: MSTP1	Description	
0	FRT running	(Initial value)
1	Clock supply to FRT halted	

Bit 0—Reserved: This bit is always read as 0. The write value should always be 0.

21.2.2 Standby Control Register 2 (SBYCR2)

Bit:	7	6	5	4	3	2	1	0
	—	—	MSTP11 (TPU)	MSTP10 (SIO2)	MSTP9 (SIO1)	MSTP8 (SIOF)	MSTP7 (SCIF2)	MSTP6 (SCIF1)
Initial value:	0	0	0	0	0	0	0	0
R/W:	R	R	R/W	R/W	R/W	R/W	R/W	R/W

Standby control register 2 (SBYCR2) is an 8-bit read/write register that sets the power-down mode state. SBYCR2 is initialized to H'00 by a reset.

Bits 7 and 6—Reserved: These bits are always read as 0. The write value should always be 0.

Bit 5—Module Stop 11 (MSTP11): Specifies halting the clock supply to the 16-bit timer pulse unit (TPU). When the MSTP11 bit is set to 1, the supply of the clock to the TPU is halted. When the clock halts, the TPU retains its pre-halt state, and the TPU interrupt vector register in the INTC retains its pre-halt value. Therefore, when MSTP11 is cleared to 0 and the clock supply to the TPU is resumed, the TPU starts operating again.

Bit 5: MSTP11 Description

0	TPU running	(Initial value)
1	Clock supply to TPU halted	

Bit 4—Module Stop 10 (MSTP10): Specifies halting the clock supply to SIO channel 2. When the MSTP10 bit is set to 1, the supply of the clock to SIO channel 2 is halted. When the clock halts, SIO channel 2 retains its pre-halt state, and the SIO channel 2 interrupt vector register in the INTC retains its pre-halt value. Therefore, when MSTP10 is cleared to 0 and the clock supply to SIO channel 2 is restarted, operation starts again.

Bit 4: MSTP10 Description

0	SIO channel 2 running	(Initial value)
1	Clock supply to SIO channel 2 halted	

Bit 3—Module Stop 9 (MSTP9): Specifies halting the clock supply to SIO channel 1. When the MSTP9 bit is set to 1, the supply of the clock to SIO channel 1 is halted. When the clock halts, SIO channel 1 retains its pre-halt state, and the SIO channel 1 interrupt vector register in the INTC retains its pre-halt value. Therefore, when MSTP9 is cleared to 0 and the clock supply to SIO channel 1 is restarted, operation starts again.

Bit 3: MSTP9	Description
0	SIO channel 1 running (Initial value)
1	Clock supply to SIO channel 1 halted

Bit 2—Module Stop 8 (MSTP8): Specifies halting the clock supply to SIOF. When the MSTP8 bit is set to 1, the supply of the clock to SIOF is halted. When the clock halts, SIOF retains its pre-halt state, and the SIOF interrupt vector register in the INTC retains its pre-halt value. Therefore, when MSTP8 is cleared to 0 and the clock supply to SIOF is restarted, operation starts again.

Bit 2: MSTP8	Description
0	SIOF running (Initial value)
1	Clock supply to SIOF halted

Bit 1—Module Stop 7 (MSTP7): Specifies halting the clock supply to SCIF2. When the MSTP7 bit is set to 1, the supply of the clock to SCIF2 is halted. When the clock halts, the SCIF2 registers are initialized, but the SCIF2 interrupt vector register in the INTC retains its pre-halt value. Therefore, when MSTP7 is cleared to 0 and SCIF2 begins running again, it starts operating from its initial state.

Bit 1: MSTP7	Description
0	SCIF2 running (Initial value)
1	Clock supply to SCIF2 halted

Bit 0—Module Stop 6 (MSTP6): Specifies halting the clock supply to SCIF1. When the MSTP6 bit is set to 1, the supply of the clock to SCIF1 is halted. When the clock halts, the SCIF1 registers are initialized, but the SCIF1 interrupt vector register in the INTC retains its pre-halt value. Therefore, when MSTP6 is cleared to 0 and SCIF1 begins running again, it starts operating from its initial state.

Bit 0: MSTP6	Description
0	SCIF1 running (Initial value)
1	Clock supply to SCIF1 halted

21.3 Sleep Mode

21.3.1 Transition to Sleep Mode

Executing the SLEEP instruction when the SBY bit in SBYCR1 is 0 causes a transition from the program execution state to sleep mode. Although the CPU halts immediately after executing the SLEEP instruction, the contents of its internal registers remain unchanged. The on-chip peripheral modules continue to run in sleep mode.

21.3.2 Canceling Sleep Mode

Sleep mode is canceled by an interrupt, DMA address error, power-on reset, or manual reset.

Cancellation by an Interrupt: When an interrupt occurs, sleep mode is canceled and interrupt exception handling is executed. Sleep mode is not canceled if the interrupt cannot be accepted because its priority level is equal to or less than the mask level set in the CPU's status register (SR) or if an interrupt by an on-chip peripheral module is disabled at the peripheral module.

Cancellation by a DMA Address Error: If a DMA address error occurs, sleep mode is canceled and DMA address error exception handling is executed.

Cancellation by a Power-On Reset: A power-on reset cancels sleep mode.

Cancellation by a Manual Reset: A manual reset cancels sleep mode.

21.4 Standby Mode

21.4.1 Transition to Standby Mode

To enter standby mode, set the SBY bit to 1 in SBYCR1, then execute the SLEEP instruction. The chip switches from the program execution state to standby mode. The NMI interrupt cannot be accepted when the SLEEP instruction is executed, or for the following five cycles. In standby mode, the clock supply to all on-chip peripheral modules is halted as well as the CPU. CPU register contents are held, and some on-chip peripheral modules are initialized.

Table 21.3 Register States in Standby Mode

Module	Registers Initialized	Registers that Retain Data	Registers with Undefined Contents
Interrupt controller (INTC)	—	All registers	—
User break controller (UBC)	—	All registers	—
Bus state controller (BSC)	—	All registers	—
Direct memory access controller (DMAC)	DMA channel control register 0, 1 DMA operation register	<ul style="list-style-type: none"> • DMA source address registers 0 and 1 • DMA destination address registers 0 and 1 • DMA transfer count registers 0 and 1 • DMA request/response selection control registers 0 and 1 • Vector number setting registers DMA0 and DMA1 	—
Watchdog timer (WDT)	Bits 7–5 of the timer control/status register Reset control/status register	Bits 2–0 of the timer control/status register Timer counter	—
16-bit free-running timer (FRT)	All registers	—	—
Serial communication interface with FIFO (SCIF1–2)	All registers	—	—
Serial I/O with FIFO (SIOF)	—	All registers	—
Serial I/O (SIO1–2)	—	All registers	—
Hitachi user debug interface (H-UDI)	—	All registers	—
16-bit timer pulse unit (TPU)	—	All registers	—
Pin function controller (PFC)	—	All registers	—
Ethernet controller direct memory access controller (E-DMAC)	All registers	—	—
Ethernet controller (EtherC)	All registers	—	—
Others	—	Standby control register 1, 2 Frequency modification register	—

21.4.2 Canceling Standby Mode

Standby mode is canceled by an NMI interrupt, a power-on reset, or a manual reset.

Cancellation by an NMI Interrupt: When a rising edge or falling edge is detected in the NMI signal, after the elapse of the time set in the WDT timer control/status register, clocks are supplied to the entire chip, standby mode is canceled, and NMI exception handling begins. Insure that the interval set for the WDT is at least as long as the oscillation stabilization time. When standby mode is canceled by a falling edge in the NMI signal, insure that the NMI pin goes high when standby mode is entered (when the clock is halted), and goes low on recovering from standby mode (when the clock starts after oscillation has stabilized). The low level at the NMI pin should be held for at least 3 cycles after the start of clock signal output from the CKIO pin. When standby mode is canceled by a rising edge in the NMI signal, insure that the NMI pin goes low when standby mode is entered (when the clock is halted), and goes high on recovering from standby mode (when the clock starts after oscillation has stabilized). The high level at the NMI pin should be held for at least 3 cycles after the start of clock signal output from the CKIO pin.

Cancellation by a Power-On Reset: A power-on reset cancels standby mode.

Cancellation by a Manual Reset: A manual reset cancels standby mode.

21.4.3 Standby Mode Cancellation by NMI Interrupt

The following example describes moving to the standby mode upon the fall of the NMI signal and clearing the standby mode when the NMI signal rises. Figure 21.1 shows the timing.

When the NMI pin level changes from high to low after the NMI edge select bit (NMIE) of the interrupt control register (ICR) has been set to 0 (detect falling edge), an NMI interrupt is accepted. When the NMIE bit is set to 1 (detect rising edge) by the NMI exception service routine, the standby bit (SBY) of the standby control register 1 (SBYCR1) is set to 1 and a SLEEP instruction is executed, the standby mode is entered. The standby mode is cleared the next time the NMI pin level changes from low level to high level. The high level at the NMI pin should be held for at least 3 cycles after the start of clock signal output from the CKIO pin.

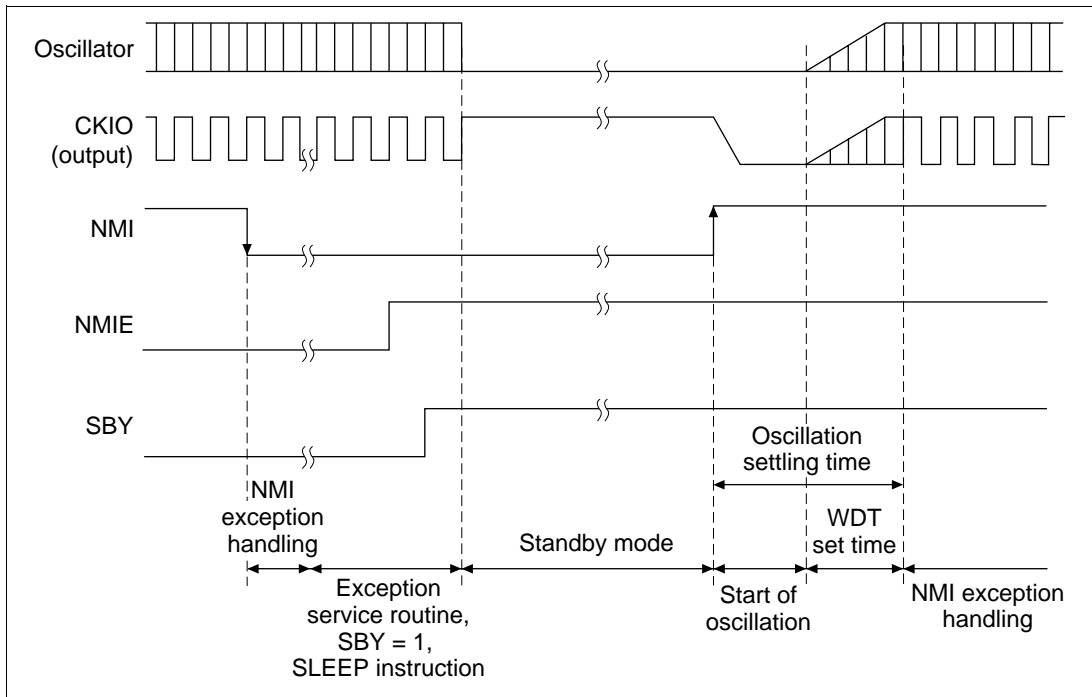

Figure 21.1 Standby Mode Cancellation by NMI Interrupt

21.4.4 Clock Pause Function

When the clock is input from the CKIO pin, the clock frequency can be modified or the clock stopped. The $\overline{\text{CKPREQ/CKM}}$ pin is provided for this purpose. Note that clock pauses are not accepted while the watchdog timer (WDT) is operating (i.e. when the timer enable bit (TME) in the WDT's timer control/status register (WTCSR) is 1). When the clock pause request function is used, the standby bit (SBY) in the standby control register 1 (SBYCR1) must be set to 1 before inputting the request signal. The clock pause function is used as described below.

1. Set the TME bit in the watchdog timer's WTCSR register to 0, and set the SBY bit in SBYCR1 to 1.
2. Apply a low level to the $\overline{\text{CKPREQ/CKM}}$ pin.
3. When the chip enters the standby state internally, a low level is output from the $\overline{\text{CKPACK}}$ pin.
4. After confirming that the $\overline{\text{CKPACK}}$ pin has gone low, perform clock halting or frequency modification.
5. To cancel the clock pause state (standby state), apply a high level to the $\overline{\text{CKPREQ/CKM}}$ pin. (Inside the chip, the standby state is canceled by detecting a rising edge at the $\overline{\text{CKPREQ/CKM}}$ pin.)

6. When PLL circuit 1 is operational, the WDT starts counting up inside the chip. When PLL circuit 1 is halted, the WDT is not activated.
7. When the internal clock stabilizes, the $\overline{\text{CKPACK}}$ pin goes high, giving external notification that the chip can be operated.

The standby state, all on-chip peripheral module states, and all pin states during clock pause are the same as in the normal standby mode. Figure 21.2 shows the timing chart for the clock pause function.

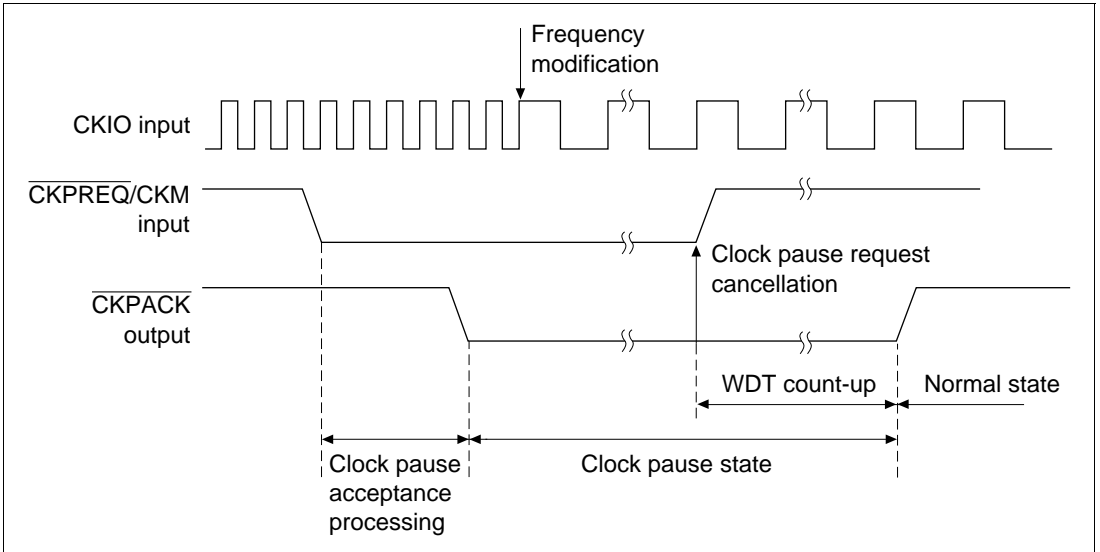

Figure 21.2 Clock Pause Function Timing Chart (PLL Circuit 1 Operating)

Figure 21.3 shows the clock pause function timing chart when the PLL circuit is halted.

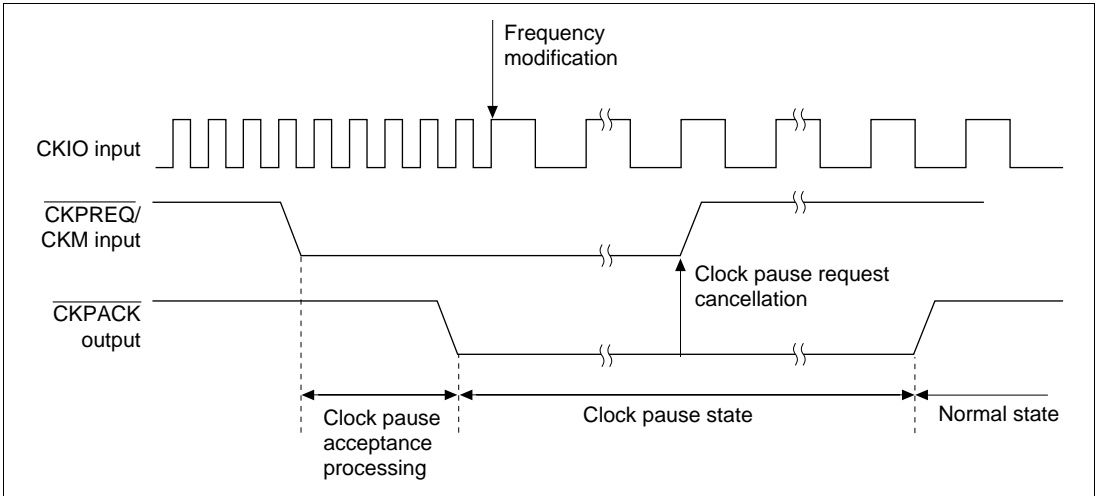

Figure 21.3 Clock Pause Function Timing Chart (PLL Circuit 1 Halted)

The clock pause state can be canceled by means of NMI input, in the same way as the normal standby state. The clock pause request should be canceled within four CKIO clock cycles after NMI input. Figure 21.4 shows the timing chart for clock pause state cancellation by means of NMI input (in the case of rising edge detection).

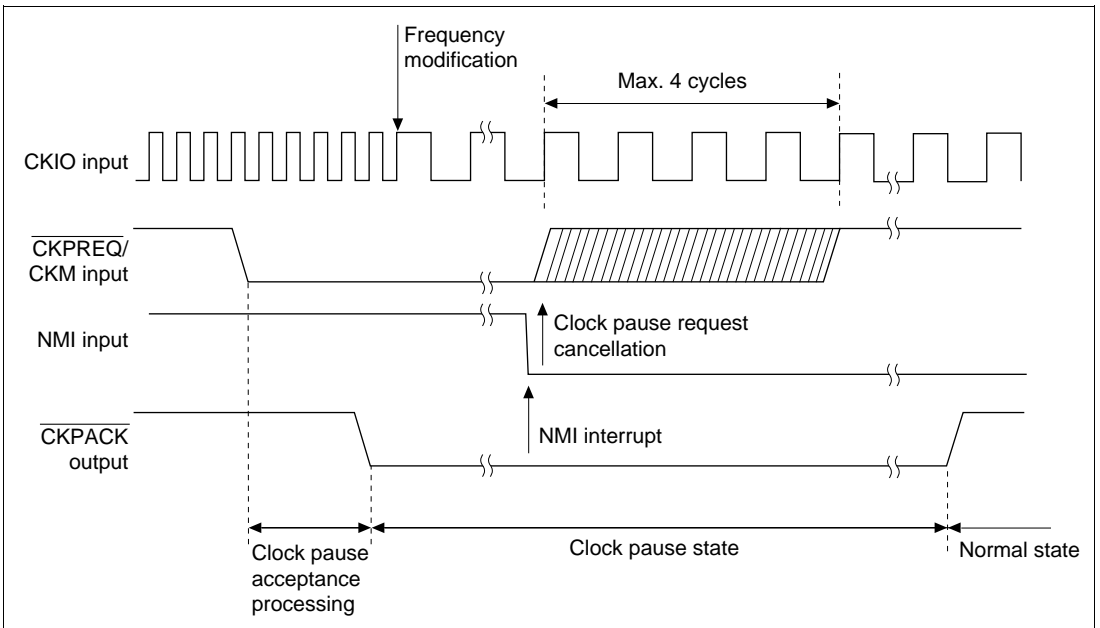

Figure 21.4 Clock Pause Function Timing Chart (Cancellation by NMI Input)

21.4.5 Notes on Standby Mode

1. When the chip enters standby mode during use of the cache, disable the cache before making the mode transition. Initialize the cache beforehand when the cache is used after returning to standby mode. The contents of the on-chip RAM are not retained in standby mode when cache is used as on-chip RAM.
2. If an on-chip peripheral register is written in the 10 clock cycles before the chip transits to standby mode, read the register before executing the SLEEP instruction.
3. When using clock mode 0, 1, or 2, the CKIO pin is the clock output pin. Note the following when standby mode is used in these clock modes. When standby mode is canceled by NMI, an unstable clock is output from the CKIO pin during the oscillation settling time after NMI input. This also applies to clock output in the case of cancellation by a power-on reset or manual reset. Power-on reset and manual reset input should be continued for a period at least equal to for the oscillation settling time.
4. Before entering the standby mode, stop operation of the internal DMAC (E-DMAC or DMAC).

21.5 Module Standby Function

21.5.1 Transition to Module Standby Function

By setting one of bits MSTP11–MSTP3, MSTP1 to 1 in standby control register 1 or 2, the supply of the clock to the corresponding on-chip peripheral module or DSP unit can be halted. This function can be used to reduce the power consumption. Do not perform read/write operations for a module in module standby mode.

With the module standby function, the external pins of the DMAC and SIO0–SIO2 on-chip peripheral modules retain their states prior to halting, as do DMAC, DSP, and SIO0–SIO2 registers. The external pins of the FRT, SCIF1–2, and TPU are reset and all their registers are initialized.

An on-chip peripheral module corresponding to a module standby bit must not be switched to the module standby state while it is running. Also, interrupts from a module placed in the module stop state should be disabled.

21.5.2 Clearing the Module Standby Function

Clear the module standby function by clearing the MSTP11–MSTP3, MSTP1 bits, or by a power-on reset or manual reset.

22.1 Absolute Maximum Ratings

Table 22.1 shows the absolute maximum ratings.

Table 22.1 Absolute Maximum Ratings

Item	Symbol	Value	Unit
Power supply voltage (internal)	V_{CC}	-0.3 to +4.2	V
Power supply voltage (5 V I/O)	PV_{CC}	-0.3 to +7.0	V
Input voltage (excluding 5 V I/O)	V_{in}	-0.3 to $V_{CC} + 0.3$	V
Input voltage (5 V I/O)	V_{in}	-0.3 to $PV_{CC} + 0.3$	V
Operating temperature	T_{opr}	-20 to +75	°C
Storage temperature	T_{stg}	-55 to +125	°C

- Notes:
1. Permanent damage to the chip may result if the maximum ratings are exceeded.
 2. When powering on, turn on the 5 V I/O power supply (PV_{CC}) after, or at the same time as, the internal power supply (V_{CC}). When powering off, cut V_{CC} after, or at the same time as, PV_{CC} .

22.2 DC Characteristics

Tables 22.2 and 22.3 show the DC characteristics.

Table 22.2 DC Characteristics

Conditions: $V_{CC} = PLLV_{CC} = 3.3\text{ V} \pm 0.3\text{ V}$, $PV_{CC} = 5.0\text{ V} \pm 0.5\text{ V}/3.3\text{ V} \pm 0.3\text{ V}$, $PV_{CC} \geq V_{CC}$,
 $V_{SS} = PV_{SS} = PLLV_{SS} = 0\text{ V}$, $T_a = -20\text{ to }+75^\circ\text{C}$

Item	Symbol	Min	Typ	Max	Unit	Test Conditions	
Input high voltage	\overline{RES} , NMI, MD4 to MD0, \overline{TRST} , CKPREQ/CKM	V_{IH}	$V_{CC} \times 0.9$	—	$V_{CC} + 0.3$	V	
	Both 3.3 V and 5 V	2.6	—	$PV_{CC} + 0.3$	V		
	EXTAL, CKIO	$V_{CC} \times 0.9$	—	$V_{CC} + 0.3$	V		
	Other input pins	$V_{CC} \times 0.7$	—	$V_{CC} + 0.3$	V		
Input low voltage	\overline{RES} , NMI, MD4 to MD0, \overline{TRST} , CKPREQ/CKM	V_{IL}	-0.3	—	$V_{CC} \times 0.1$	V	
	Other input pins	-0.3	—	0.8	V		
Schmitt trigger input voltage	PB14/RXD1, PB5/SRS1/RXD2	VT^-	—	—	0.8	V	
		VT^+	4.0	—	—	V	$PV_{CC} = 5\text{ V} \pm 0.5\text{ V}$
		VT^+	2.6	—	—	V	Other than above
		$VT^+ - VT^-$	0.3	—	—	V	
Input leakage current	All input pins	$ I_{in} $	—	—	1.0	μA	$V_{in} = 0.5\text{ to }V_{CC} - 0.5\text{ V}$ $V_{in} = 0.5\text{ to }PV_{CC} - 0.5\text{ V}$
Three-state leakage current	All I/O and output pins (off status)	$ I_{STI} $	—	—	1.0	μA	$V_{in} = 0.5\text{ to }V_{CC} - 0.5\text{ V}$ $V_{in} = 0.5\text{ to }PV_{CC} - 0.5\text{ V}$
Output high voltage	Both 3.3 V and 5 V	V_{OH}	$PV_{CC} - 0.7$	—	—	V	$IOH = -200\text{ }\mu\text{A}$
	Other output pins		$V_{CC} - 0.5$	—	—	V	$IOH = -200\text{ }\mu\text{A}$
			$V_{CC} - 1.0$	—	—	V	$IOH = -1\text{ mA}$
Output low voltage	Both 3.3 V and 5 V	V_{OL}	—	—	0.6	V	$IOL = 1.6\text{ mA}$
	Other output pins		—	—	0.4	V	$IOL = 1.6\text{ mA}$

Table 22.2 DC Characteristics (cont)

Conditions: $V_{CC} = PLLV_{CC} = 3.3 \text{ V} \pm 0.3 \text{ V}$, $PV_{CC} = 5.0 \text{ V} \pm 0.5 \text{ V}/3.3 \text{ V} \pm 0.3 \text{ V}$, $PV_{CC} \geq V_{CC}$,
 $V_{SS} = PV_{SS} = PLLV_{SS} = 0 \text{ V}$, $T_a = -20 \text{ to } +75^\circ\text{C}$

Item	Symbol	Min	Typ	Max	Unit	Test Conditions	
Pin capacitance	CAP1, CAP2	Cin	—	—	40	pF	$T_a = 25^\circ\text{C}$
	Other input pins		—	—	15	pF	
Current dissipation	Normal operation	Icc	—	—	350	mA	3.6 V, CPU operating clock = 62.5 MHz, DMAC used
			—	—	300	mA	3.6 V, CPU operating clock = 62.5 MHz, DMAC not used
	Sleep mode		—	—	250	mA	3.6 V, CPU operating clock = 62.5 MHz, peripheral modules not used
			—	—	990	μA	

Note: Do not leave the PLLVcc and PLLVss pins open when the PLL circuit is not used. Connect the PLLVcc pin to Vcc and the PLLVss pin to Vss.

Table 22.3 Permissible Output Currents

Conditions: $V_{CC} = PLLV_{CC} = 3.3 \text{ V} \pm 0.3 \text{ V}$, $PV_{CC} = 5.0 \text{ V} \pm 0.5 \text{ V}/3.3 \text{ V} \pm 0.3 \text{ V}$, $PV_{CC} \geq V_{CC}$,
 $V_{SS} = PV_{SS} = PLLV_{SS} = 0 \text{ V}$, $T_a = -20 \text{ to } +75^\circ\text{C}$

Item	Symbol	Min	Typ	Max	Unit
Permissible output low current (per pin)	I_{OL}	—	—	2.0	mA
Permissible output low current (total)	$\sum I_{OL}$	—	—	80	mA
Permissible output high current (per pin)	$-I_{OH}$	—	—	2.0	mA
Permissible output high current (total)	$\sum(-I_{OH})$	—	—	25	mA

Note: To protect chip reliability, do not exceed the output current values in table 22.3.

22.3 AC Characteristics

In principle, input is synchronous. Unless specified otherwise, ensure that the setup time and hold times for each input signal are observed.

Table 22.4 Maximum Operating Frequencies

Conditions: $V_{CC} = PLLV_{CC} = 3.3 \text{ V} \pm 0.3 \text{ V}$, $PV_{CC} = 5.0 \text{ V} \pm 0.5 \text{ V}/3.3 \text{ V} \pm 0.3 \text{ V}$, $PV_{CC} \geq V_{CC}$,
 $V_{SS} = PV_{SS} = PLLV_{SS} = 0 \text{ V}$, $T_a = -20 \text{ to } +75^\circ\text{C}$

Item		Symbol	Min	Typ	Max	Unit	Notes
Operating frequency	CPU, DSP	f	1	—	62.5	MHz	$t_{l_{cyc}}$
	External bus (SDRAM not used)		1	—	31.25		$t_{E_{cyc}}$
	External bus (SDRAM used)		1	—	62.5		$t_{E_{cyc}}$
	Peripheral modules		1	—	31.25		$t_{P_{cyc}}$

22.3.1 Clock Timing

Table 22.5 Clock Timing

Conditions: $V_{CC} = PLLV_{CC} = 3.3\text{ V} \pm 0.3\text{ V}$, $PV_{CC} = 5.0\text{ V} \pm 0.5\text{ V}/3.3\text{ V} \pm 0.3\text{ V}$, $PV_{CC} \geq V_{CC}$,
 $V_{SS} = PV_{SS} = PLLV_{SS} = 0\text{ V}$, $T_a = -20\text{ to }+75^\circ\text{C}$

Item	Symbol	Min	Max	Unit	Figure
EXTAL clock input frequency	fEX	1	31.25	MHz	22.1
EXTAL clock input cycle time	tEXcyc	32	1000	ns	
EXTAL clock input low-level pulse width	tEXL	8* ¹ , 12* ²	—	ns	
EXTAL clock input high-level pulse width	tEXH	8* ¹ , 12* ²	—	ns	
EXTAL clock input rise time	tEXR	—	4	ns	
EXTAL clock input fall time	tEXF	—	4	ns	
CKIO clock input frequency	fCKI	1	31.25	MHz	22.2
CKIO clock input cycle time	tCKIcyc	32	1000	ns	
CKIO clock input low-level pulse width	tCKIL	8* ³ , 12* ⁴	—	ns	
CKIO clock input high-level pulse width	tCKIH	8* ³ , 12* ⁴	—	ns	
CKIO clock input rise time	tCKIR	—	4	ns	
CKIO clock input fall time	tCKIF	—	4	ns	
CKIO clock output frequency	fOP	1* ⁵ , 8* ⁶	62.5	MHz	22.3
CKIO clock output cycle time	tcyc	16	1000* ⁵ , 125* ⁶	ns	
CKIO clock output low-level pulse width	tCKOL	3	—	ns	
CKIO clock output high-level pulse width	tCKOH	3	—	ns	
CKIO clock rise time	tCKOR	—	5	ns	
CKIO clock fall time	tCKOF	—	5	ns	
Power-on oscillation stabilization time	tOSC1	10	—	ms	22.4
Standby recovery oscillation stabilization time 1	tOSC2	10	—	ms	22.5
Standby recovery oscillation stabilization time 2	tOSC3	10	—	ms	22.6
PLL synchronization stabilization time	tPLL	1	—	ms	22.7

Notes: *1 When PLL circuit 2 is operating
*2 When PLL circuit 2 is not used
*3 When PLL circuit 1 is operating
*4 When PLL circuit 1 is not used
*5 When PLL circuit 1 and 2 are not used
*6 When PLL circuit 1 or 2 is operating

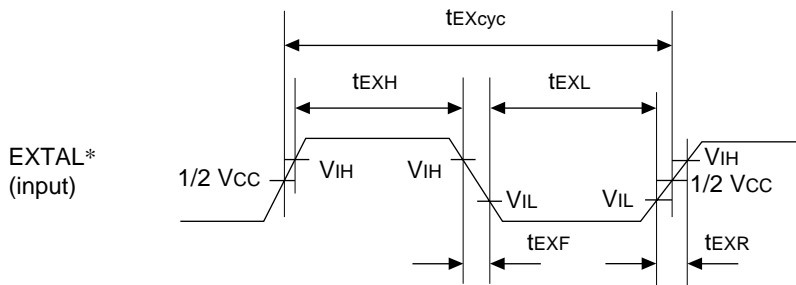

Note: * When clock is input from EXTAL pin

Figure 22.1 EXTAL Clock Input Timing

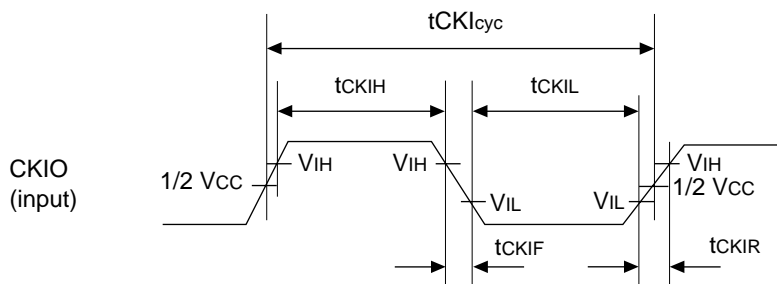

Figure 22.2 CKIO Clock Input Timing

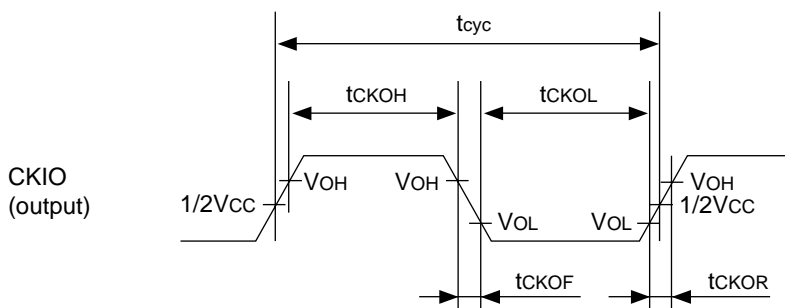
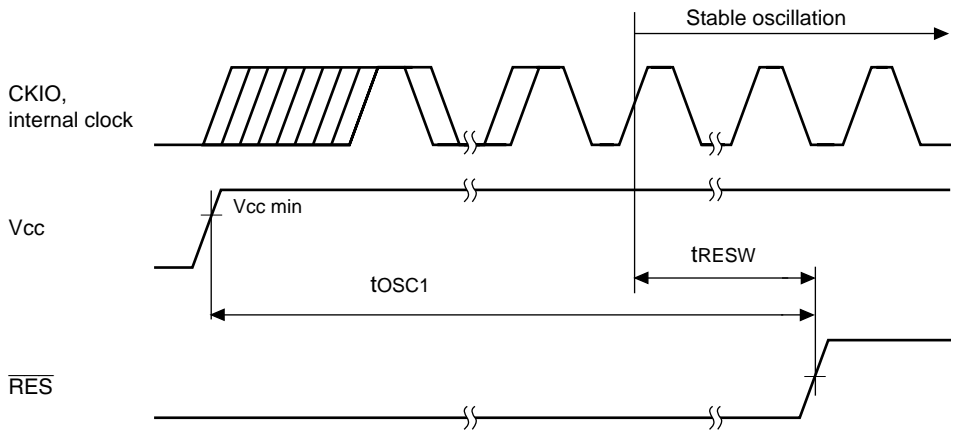
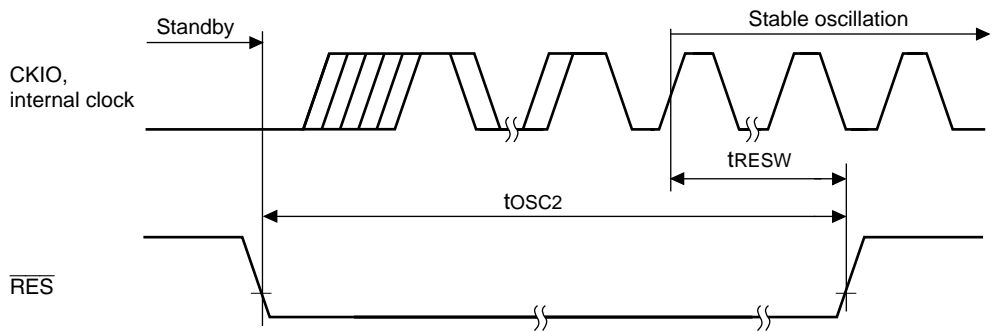

Figure 22.3 CKIO Clock Output Timing



Note: Oscillation stabilization time when using on-chip crystal oscillator

Figure 22.4 Power-On Oscillation Stabilization Time at Power-On



Note: Oscillation stabilization time when using on-chip crystal oscillator

Figure 22.5 Oscillation Stabilization Time after Standby Recovery (Recovery by $\overline{\text{RES}}$)

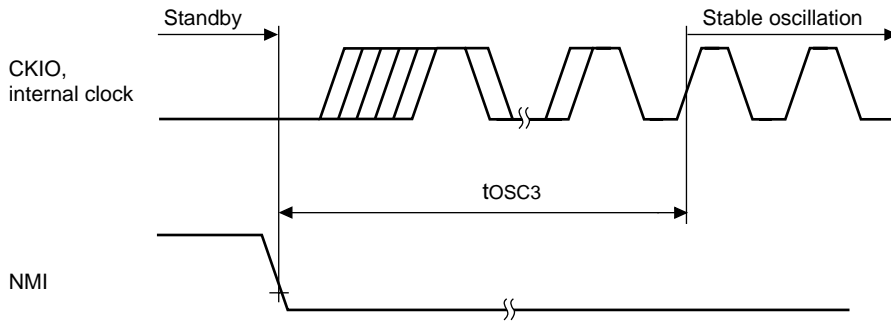

Note: Oscillation stabilization time when using on-chip crystal oscillator

Figure 22.6 Oscillation Stabilization Time after Standby Recovery (Recovery by NMI)

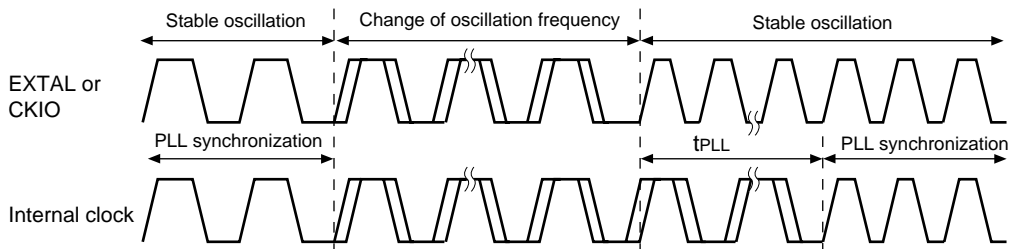

Figure 22.7 PLL Synchronization Stabilization Time

22.3.2 Control Signal Timing

Table 22.6 Control Signal Timing

Conditions: $V_{CC} = PLLV_{CC} = 3.3\text{ V} \pm 0.3\text{ V}$, $PV_{CC} = 5.0\text{ V} \pm 0.5\text{ V}/3.3\text{ V} \pm 0.3\text{ V}$, $PV_{CC} \geq V_{CC}$,
 $V_{SS} = PV_{SS} = PLLV_{SS} = 0\text{ V}$, $T_a = -20\text{ to }+75^\circ\text{C}$

Item	Symbol	Min	Max	Unit	Figure
$\overline{\text{RES}}$ rise and fall time	tRESr, tRESf	—	200	ns	22.8
$\overline{\text{RES}}$ pulse width	tRESW	20	—	tPcyc	
NMI reset setup time	tNMIRS	tPcyc + 10	—	ns	
NMI reset hold time	tNMIRH	tPcyc + 10	—	ns	
NMI rise and fall time	tNMIr, tNMIf	—	200	ns	
$\overline{\text{RES}}$ setup time*	tRESS	3tEcyc + 40	—	ns	22.9
NMI setup time*	tNMIS	40	—	ns	
$\overline{\text{IRL3}}\text{--}\overline{\text{IRL0}}$ setup time*	tIRLS	30	—	ns	
NMI hold time	tNMIH	20	—	ns	
$\overline{\text{IRL3}}\text{--}\overline{\text{IRL0}}$ hold time*	tIRLH	20	—	ns	
$\overline{\text{BRLS}}$ setup time	tBLSS	10	—	ns	22.10
$\overline{\text{BRLS}}$ hold time	tBLSH	5	—	ns	
$\overline{\text{BGR}}$ delay time	tBGRD	—	15	ns	
Bus tri-state delay time	tBOFF	0	35	ns	
Bus buffer on time	tBON	0	35	ns	

Note: * The $\overline{\text{RES}}$, NMI, and $\overline{\text{IRL3}}\text{--}\overline{\text{IRL0}}$ signals are asynchronous inputs. If the setup times shown here are observed, a transition is judged to have occurred at the fall of the clock; if the setup times cannot be observed, recognition may be delayed until the next fall of the clock.

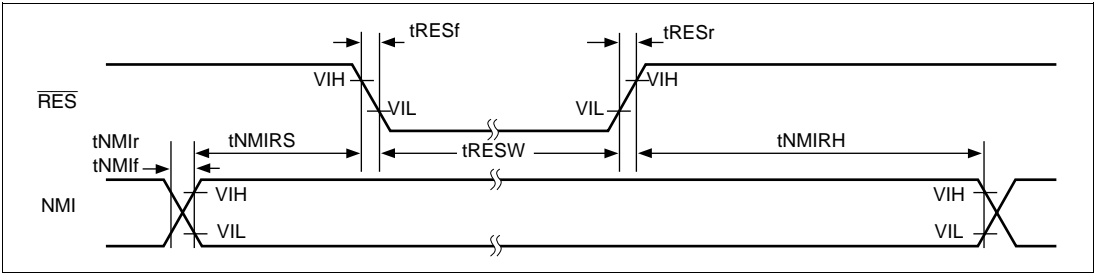

Figure 22.8 Reset Input Timing

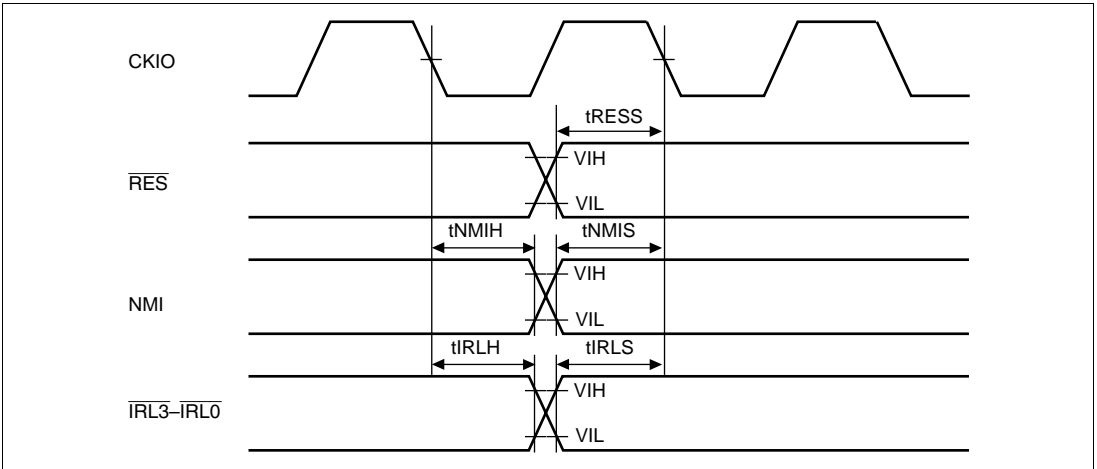

Figure 22.9 Interrupt Signal Input Timing

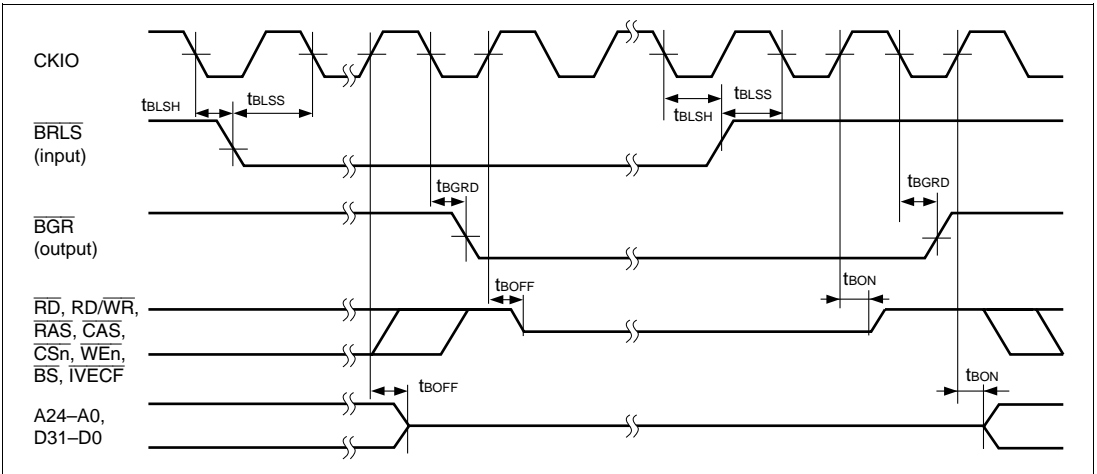

Figure 22.10 Bus Release Timing

22.3.3 Bus Timing

Table 22.7 PLL-On Bus Timing [Modes 0 and 4] (1)

Conditions: $V_{CC} = PLLV_{CC} = 3.3\text{ V} \pm 0.3\text{ V}$, $PV_{CC} = 5.0\text{ V} \pm 0.5\text{ V}/3.3\text{ V} \pm 0.3\text{ V}$, $PV_{CC} \geq V_{CC}$,
 $V_{SS} = PV_{SS} = PLLV_{SS} = 0\text{ V}$, $T_a = -20\text{ to }+75^\circ\text{C}$

Item	Symbol	Min	Max	Unit	Figure
Address delay time	t_{AD}	1	14	ns	22.11, 12, 15, 16, 18, 20, 22, 24 to 28, 30 to 34, 37 to 40, 42 to 44
\overline{BS} delay time	t_{BSD}	—	15	ns	22.11, 12, 15, 16, 18, 20, 22, 24, 25, 28, 30, 31, 33, 34, 39, 42 to 44
\overline{CS} delay time 1	t_{CSD1}	1	14	ns	22.11, 12, 15, 16, 18, 20, 22 to 25, 28, 30 to 34, 39, 41, 42
\overline{CS} delay time 2	t_{CSD2}	—	14	ns	22.11, 12, 33, 34, 39, 42
Read/write delay time	t_{RWD}	1	14	ns	22.11, 12, 15, 16, 18, 20 to 22, 24, 25, 28 to 34, 39, 42 to 44
Read strobe delay time 1	t_{RSD1}	—	14	ns	22.11, 12, 15, 16, 22, 30, 33, 34, 37, 39, 40, 42 to 44
Read data setup time 1	t_{RDS1}	8	—	ns	22.11, 33, 37, 42 to 44
Read data setup time 2 (EDO)	t_{RDS2}	8	—	ns	22.39, 40
Read data setup time 3 (SDRAM)	t_{RDS3}	6.5	—	ns	22.15, 16
Read data hold time 2	t_{RDH2}	0	—	ns	22.11, 42
Read data hold time 4 (SDRAM)	t_{RDH4}	2	—	ns	22.15, 16
Read data hold time 5 (DRAM)	t_{RDH5}	0	—	ns	22.33, 37
Read data hold time 6 (EDO)	t_{RDH6}	3	—	ns	22.39, 40
Read data hold time 7 (EDO)	t_{RDH7}	1	—	ns	22.39
Read data hold time 8 (interrupt vector)	t_{RDH8}	2	—	ns	22.43, 44
Write enable delay time 1	t_{WED1}	—	14	ns	22.11, 12
Write data delay time 1 (except $E\emptyset$: $I\emptyset = 1:1$)	t_{WDD1}	—	22	ns	22.12, 22, 24, 26, 34, 38
Write data delay time 2 ($E\emptyset$: $I\emptyset = 1:1$)	t_{WDD2}	—	12	ns	22.25, 27
Write data hold time 1	t_{WDH1}	2	—	ns	22.12, 22, 24 to 27, 34, 38
Data buffer on time	t_{DON}	—	15	ns	22.12, 22, 24, 25, 34
Data buffer off time	t_{DOF}	—	15	ns	22.12, 22, 24, 25, 34

Table 22.7 PLL-On Bus Timing [Modes 0 and 4] (1) (cont)

Conditions: $V_{CC} = PLLV_{CC} = 3.3\text{ V} \pm 0.3\text{ V}$, $PV_{CC} = 5.0\text{ V} \pm 0.5\text{ V}/3.3\text{ V} \pm 0.3\text{ V}$, $PV_{CC} \geq V_{CC}$,
 $V_{SS} = PV_{SS} = PLLV_{SS} = 0\text{ V}$, $T_a = -20\text{ to }+75^\circ\text{C}$

Item	Symbol	Min	Max	Unit	Figure
DACK delay time 1	t_{DACD1}	—	14	ns	22.11, 12, 15, 18, 20, 22, 24, 25, 28, 33, 34, 37 to 40, 42
DACK delay time 2	t_{DACD2}	—	14	ns	22.11, 12, 33, 34, 37 to 40, 42
WAIT setup time	t_{WTS}	10	—	ns	22.13, 14, 35, 36, 42 to 45
WAIT hold time	t_{WTH}	5	—	ns	22.13, 14, 35, 36, 42 to 45
RAS delay time 1 (SDRAM)	t_{RASD1}	1	14	ns	22.15 to 18, 20 to 25, 28 to 32
RAS delay time 2 (DRAM, EDO)	t_{RASD2}	—	14	ns	22.33, 34, 39, 41
RAS delay time 3 (EDO)	t_{RASD3}	—	14	ns	22.39
CAS delay time 1 (SDRAM)	t_{CASD1}	1	14	ns	22.15, 16, 17, 18, 22 to 28, 30 to 32, 42
CAS delay time 2 (DRAM)	t_{CASD2}	—	14	ns	22.33, 34, 37 to 41
DQM delay time	t_{DQMD}	1	14	ns	22.15, 16, 18 to 20, 22, 24 to 29
CKE delay time	t_{CKED}	1	14	ns	22.32
OE delay time 1	t_{OED1}	—	14	ns	22.39
OE delay time 2	t_{OED2}	—	14	ns	22.39
IVECF delay time	t_{IVD}	—	15	ns	22.43, 44
Row address setup time	t_{ASR}	0	—	ns	22.33, 34, 39
Column address setup time	t_{ASC}	0	—	ns	22.33, 34, 37, 38, 39
Data input setup time	t_{DS}	0	—	ns	22.34, 38
Read/write address setup time	t_{AS}	0	—	ns	22.11, 12
REFOUT delay time	t_{REFOD}	—	15	ns	22.46

Table 22.7 PLL-On Bus Timing [Modes 0 and 4] (2)

Conditions: $V_{CC} = PLLV_{CC} = 3.3\text{ V} \pm 5\%$, $PV_{CC} = 5.0\text{ V} \pm 5\%/3.3\text{ V} \pm 5\%$, $PV_{CC} \geq V_{CC}$,
 $V_{SS} = PV_{SS} = PLLV_{SS} = 0\text{ V}$, $T_a = -5\text{ to }+70^\circ\text{C}$, SDRAM bus cycle

Item	Symbol	Min	Max	Unit	Figure
Read data setup time 3 (SDRAM)	t_{RDS3}	6.5	—	ns	22.15, 16
Read data hold time 4 (SDRAM)	t_{RDH4}	1.5	—	ns	22.15, 16
Write data delay time 2 (E \emptyset : I \emptyset = 1:1)	t_{WDD2}	—	9.5	ns	22.25, 27
Write data hold time 1	t_{WDH1}	2	—	ns	22.25, 27
Address delay time	t_{AD}	4	11	ns	22.15, 16, 18, 20, 22, 24, 25, 26, 27, 28, 30, 31, 32
$\overline{\text{CS}}$ delay time 1	t_{CSD1}	2.5	9.5	ns	22.15, 16, 18, 20, 22, 23, 24, 25, 28, 30, 31, 32
Read/write delay time	t_{RWD}	2.5	9.5	ns	22.15, 16, 18, 20, 21, 22, 24, 25, 28, 29, 30, 31, 32
DQM delay time	t_{DQMD}	2.5	9.5	ns	22.15, 16, 18, 19, 20, 22, 24, 25, 26, 27, 28, 29
$\overline{\text{RAS}}$ delay time 1 (SDRAM)	t_{RASD1}	2.5	9.5	ns	22.15, 16, 17, 20, 21, 22, 23, 24, 25, 28, 29, 30, 31, 32
$\overline{\text{CAS}}$ delay time 1 (SDRAM)	t_{CASD1}	2.5	9.5	ns	22.15, 16, 17, 18, 22, 23, 24, 25, 26, 27, 28, 30, 31, 32
CKE delay time	t_{CKED}	2.5	9.5	ns	22.32

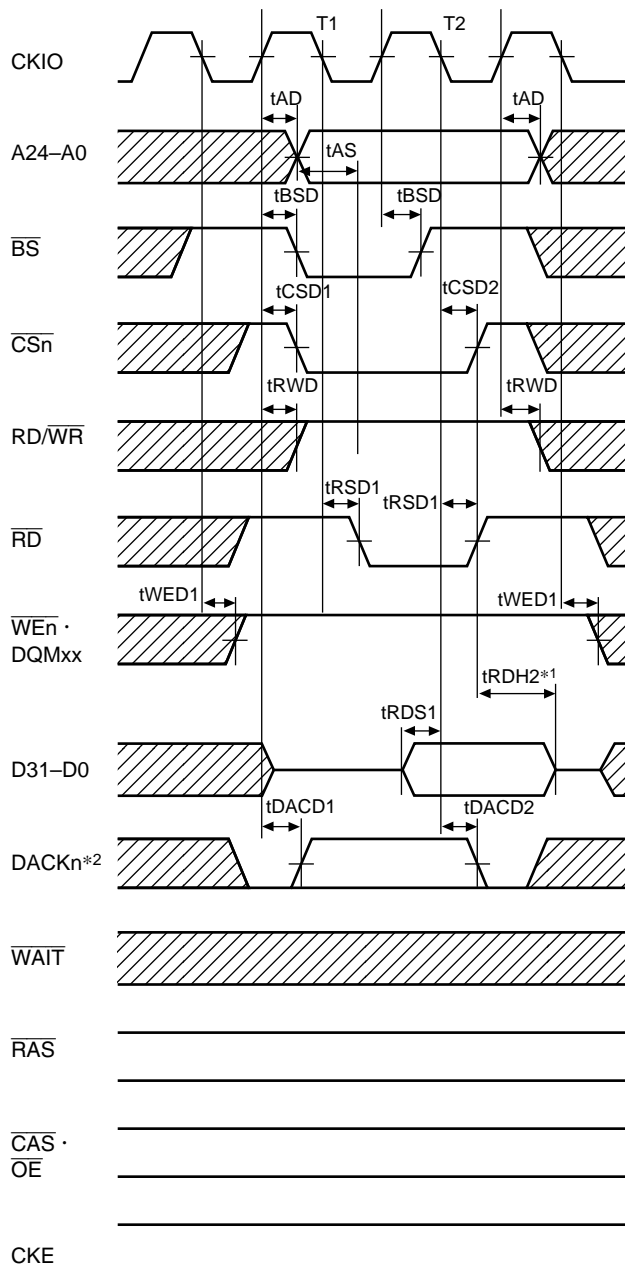

Notes: *1 t_{RDH2} is measured from the rise of \overline{CSn} or \overline{RD} , whichever comes first.
 *2 DACKn waveform when active-high is specified

Figure 22.11 Basic Read Cycle (No Wait)

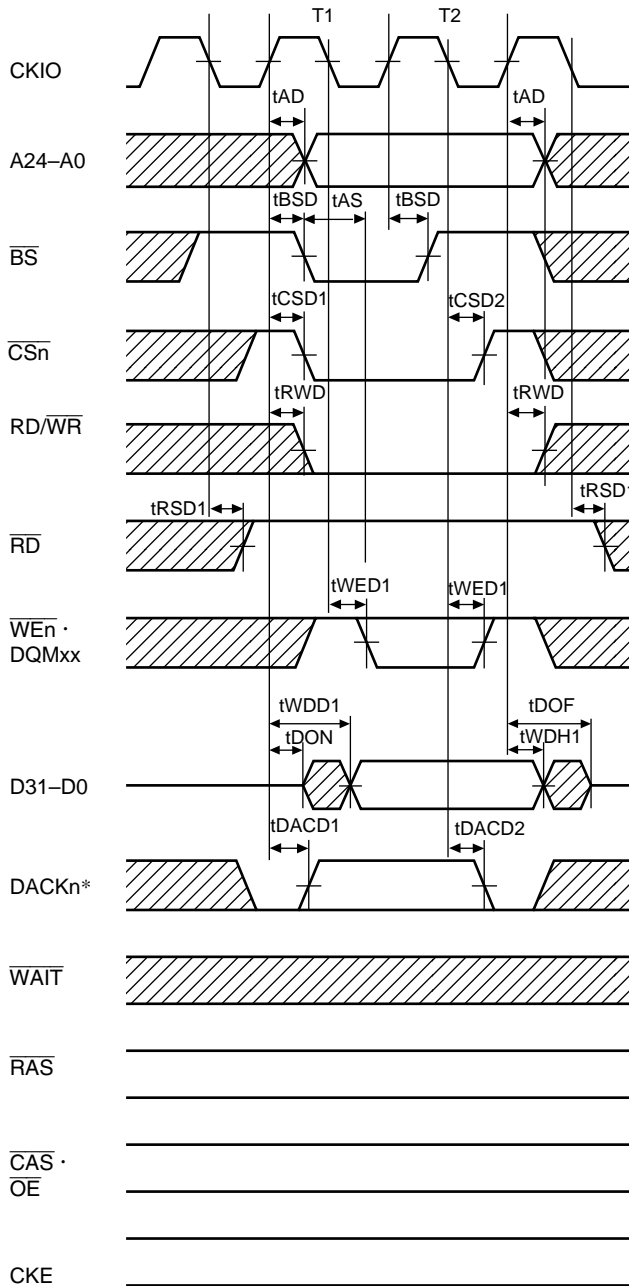

Note: * DACK_n waveform when active-high is specified

Figure 22.12 Basic Write Cycle (No Wait)

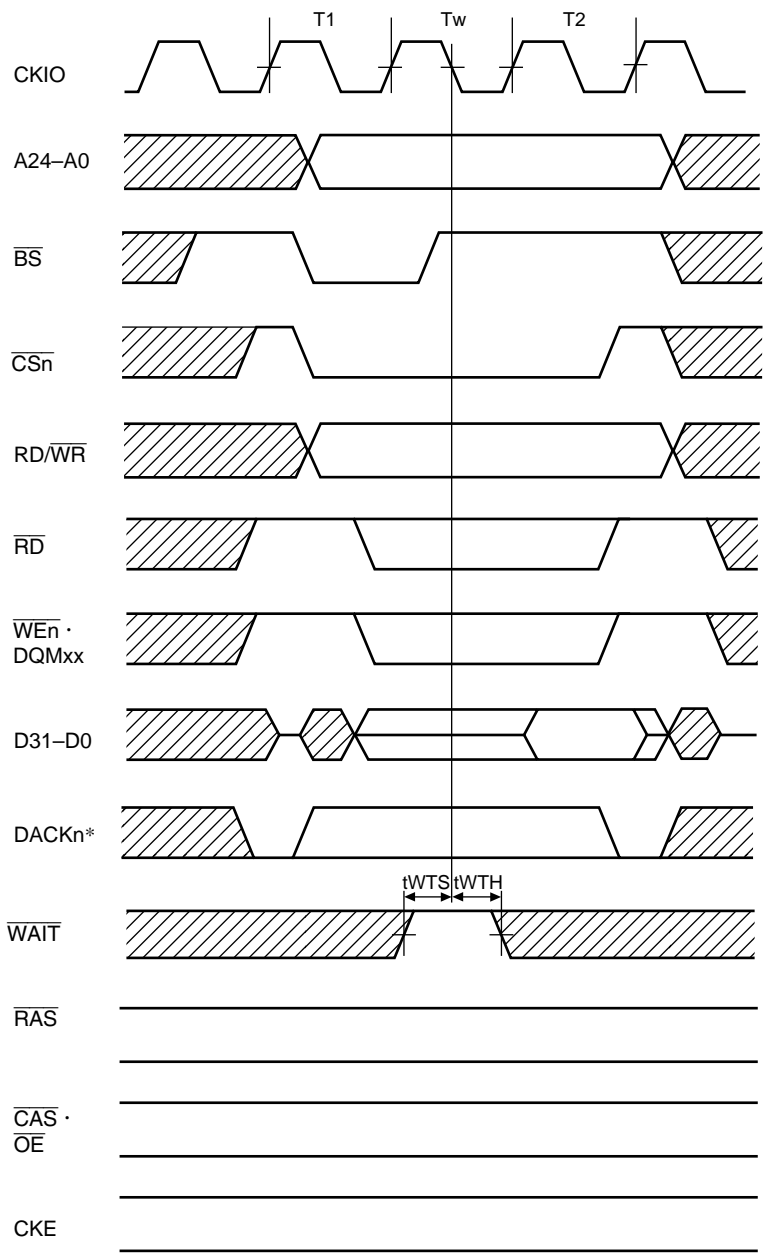

Note: * DACKn waveform when active-high is specified

Figure 22.13 Basic Bus Cycle (1 Wait Cycle)

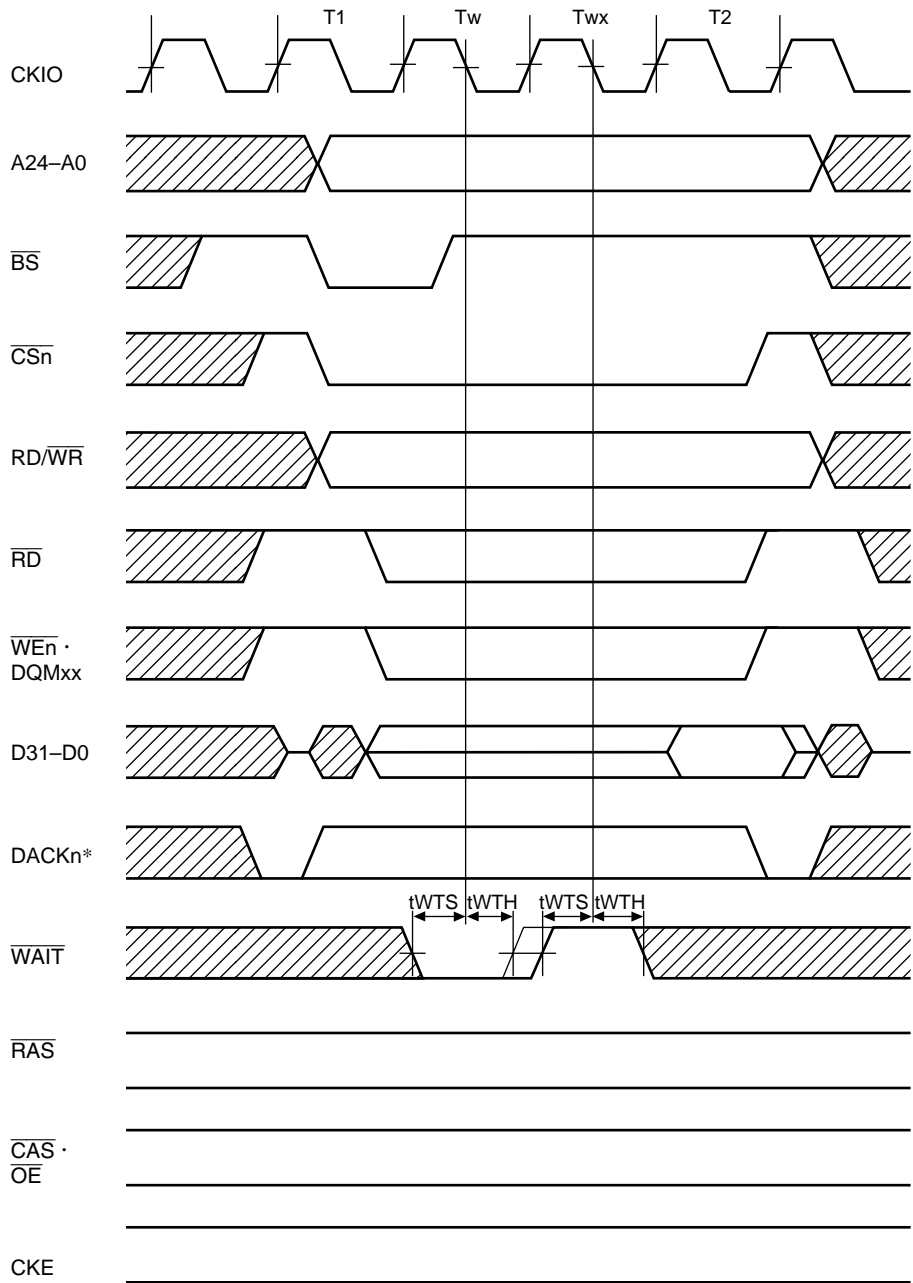

Note: * DACKn waveform when active-high is specified

Figure 22.14 Basic Bus Cycle (External Wait Input)

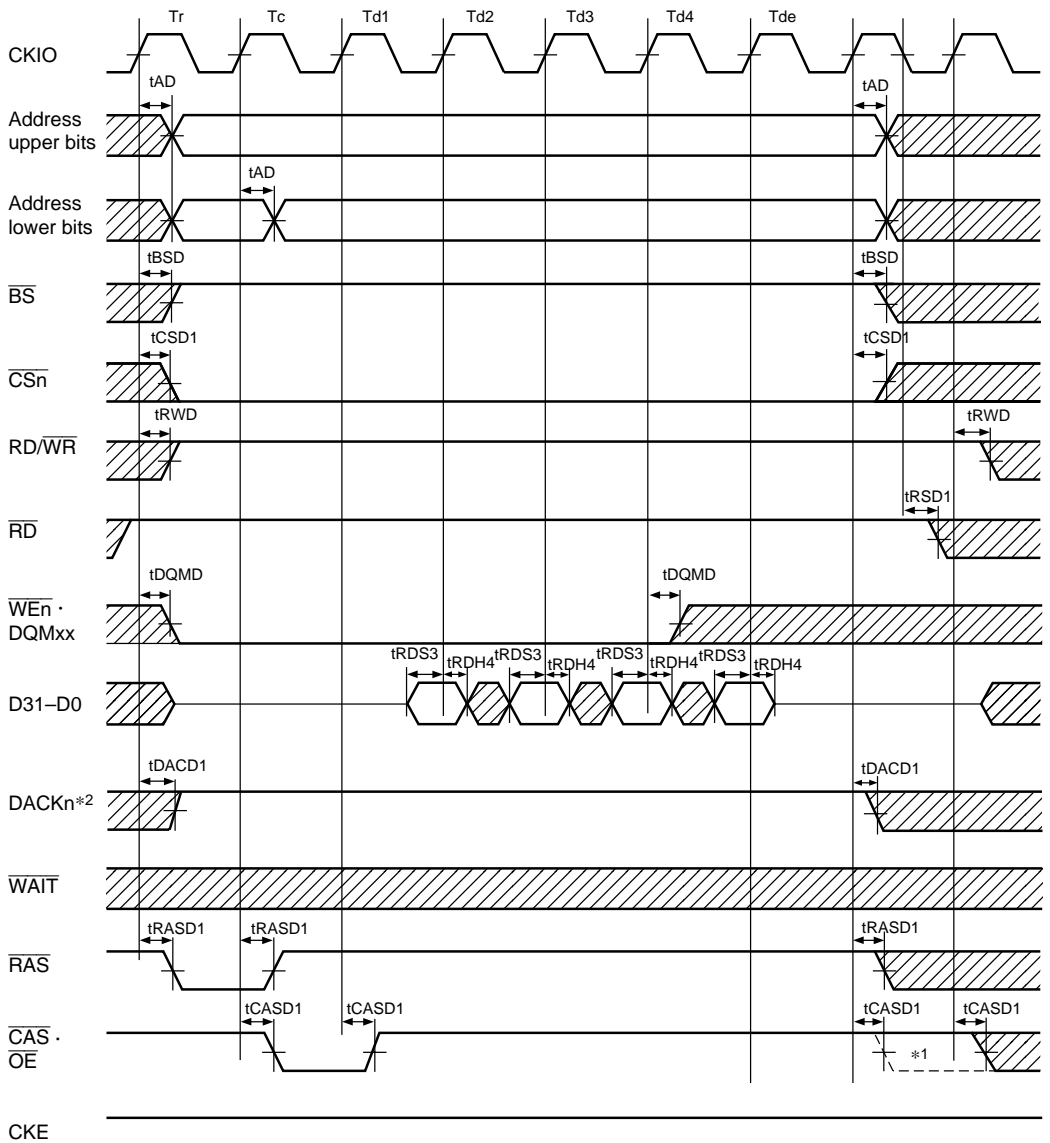

Notes: *1 Dotted line shows the case where synchronous DRAM in a different CS space is accessed.

*2 DACKn waveform when active-high is specified

**Figure 22.15 Synchronous DRAM Read Bus Cycle
(RCD = 1 Cycle, CAS Latency = 1 Cycle, Burst = 4)**

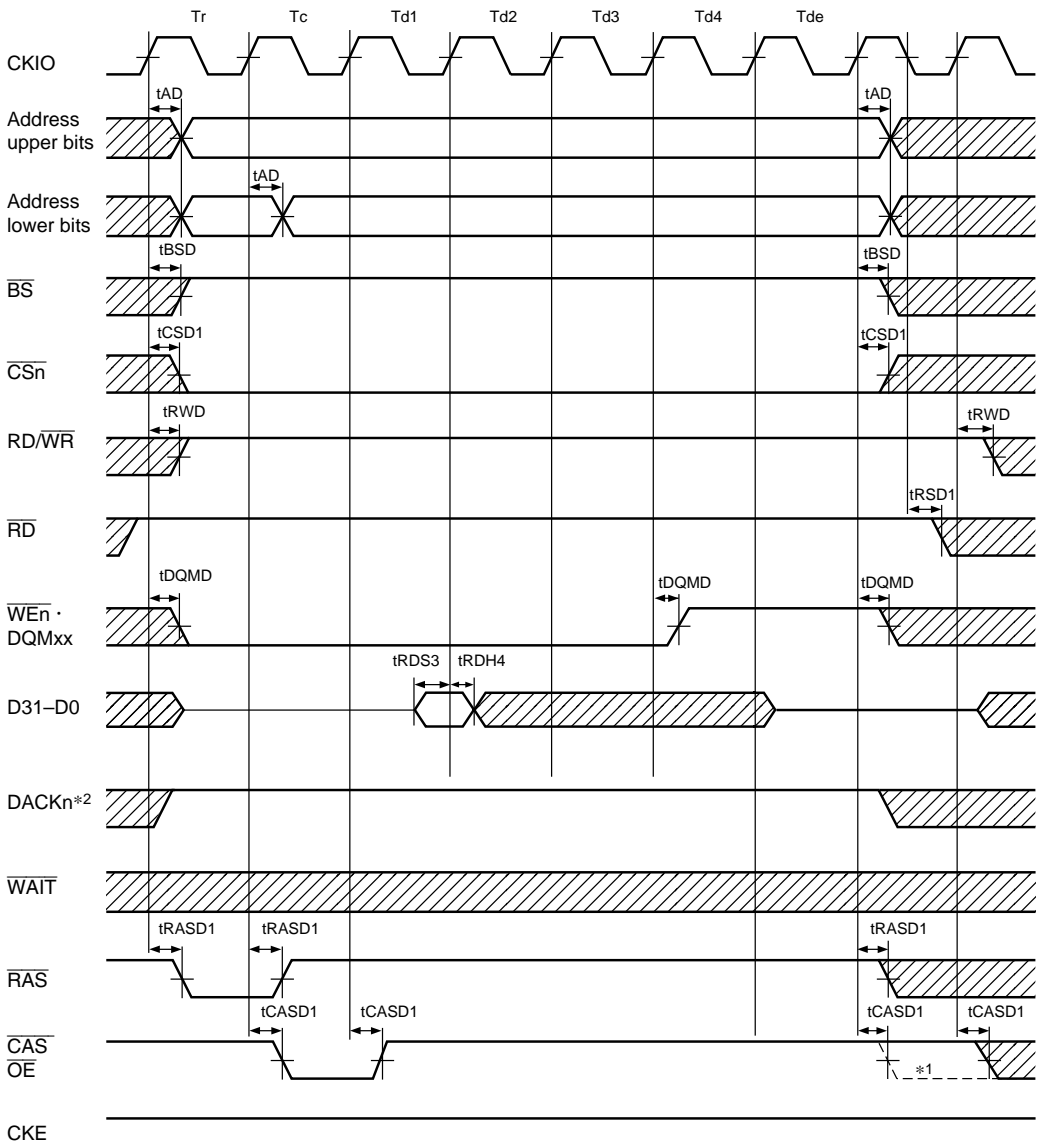

Notes: *1 Dotted line shows the case where synchronous DRAM in a different CS space is accessed.

*2 DACKn waveform when active-high is specified

**Figure 22.16 Synchronous DRAM Single Read Bus Cycle
(RCD = 1 Cycle, CAS Latency = 1 Cycle, Burst = 4)**

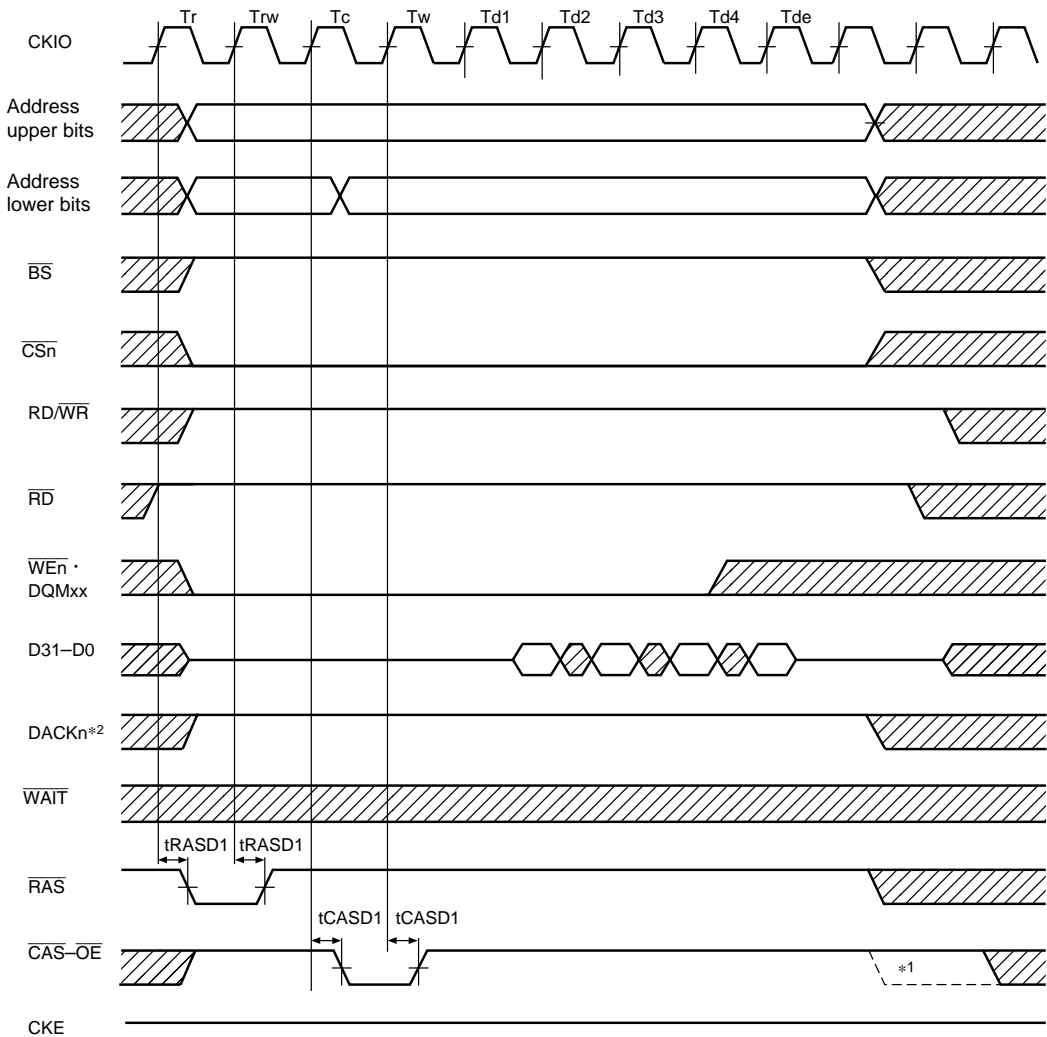

Notes: *1 Dotted line shows the case where synchronous DRAM in a different CS space is accessed.

*2 DACKn waveform when active-high is specified

Figure 22.17 Synchronous DRAM Read Bus Cycle
(RCD = 2 Cycles, CAS Latency = 2 Cycles, Burst = 4)

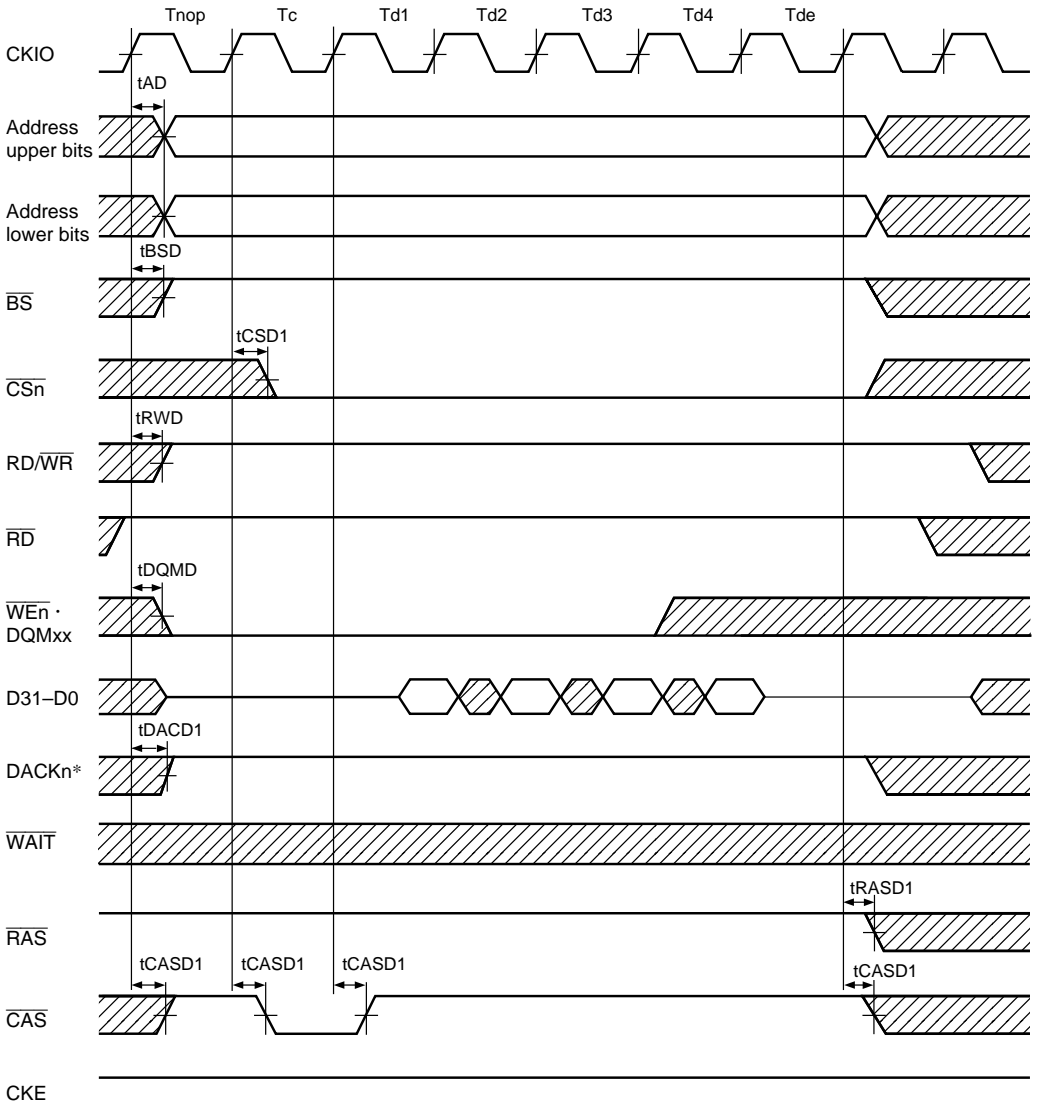

Note: * DACKn waveform when active-high is specified

**Figure 22.18 Synchronous DRAM Read Bus Cycle
(Bank Active, Same Row Access, CAS Latency = 1 Cycle)**

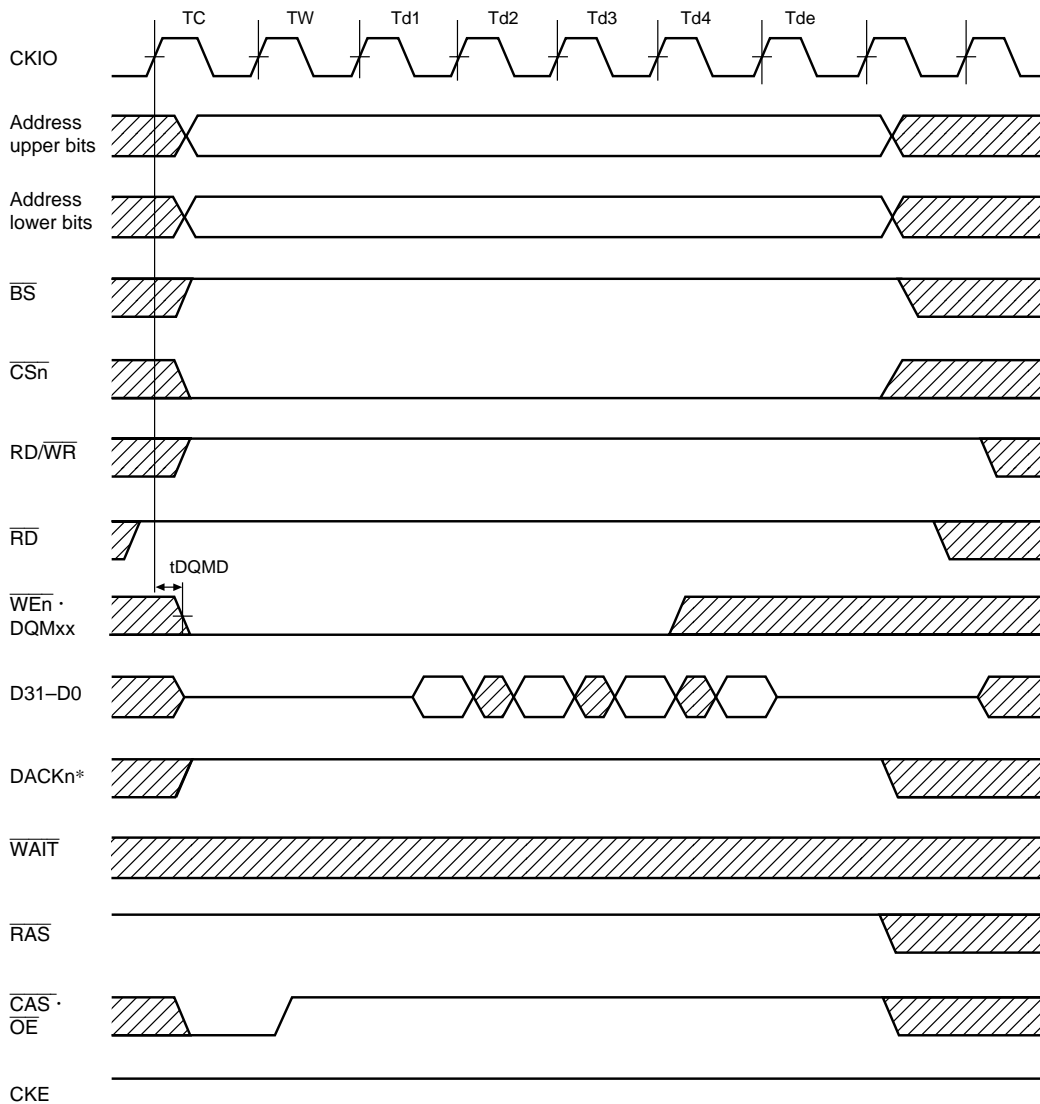

Note: * DACKn waveform when active-high is specified

Figure 22.19 Synchronous DRAM Read Bus Cycle
(Bank Active, Same Row Access, CAS Latency = 2 Cycles)

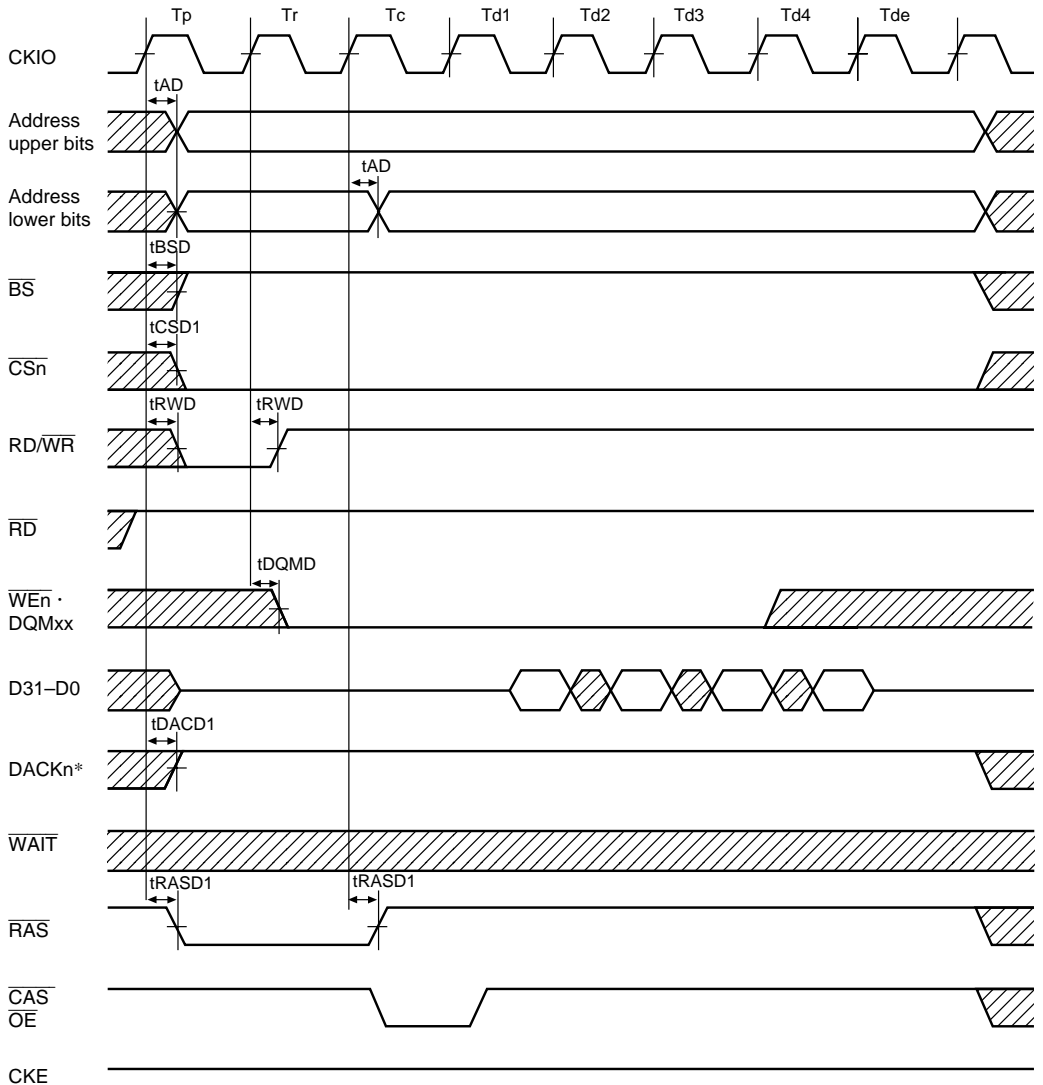

Note: * DACKn waveform when active-high is specified

Figure 22.20 Synchronous DRAM Read Bus Cycle
(Bank Active, Different Row Access, TRP = 1 Cycle, RCD = 1 Cycle, CAS Latency = 1 Cycle)

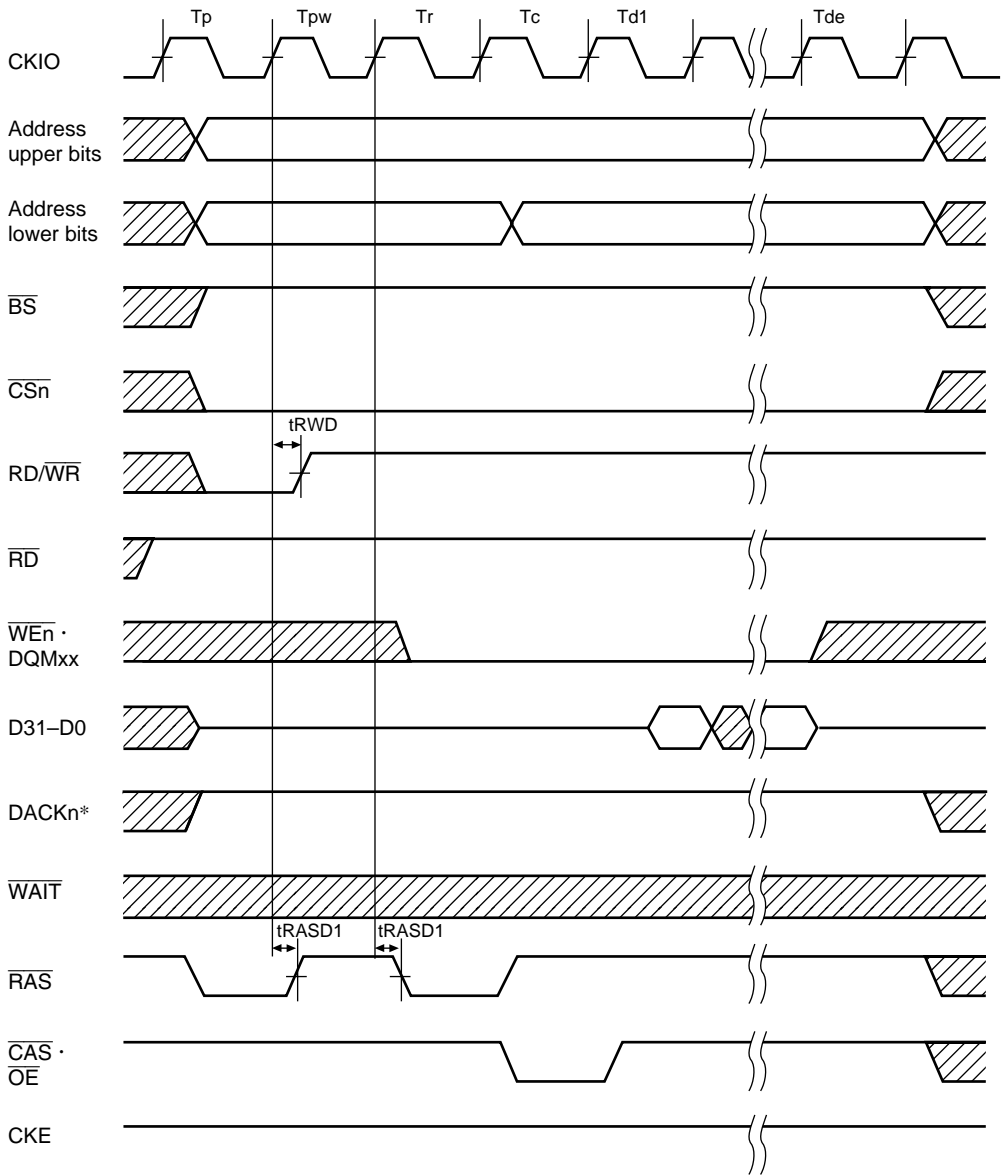
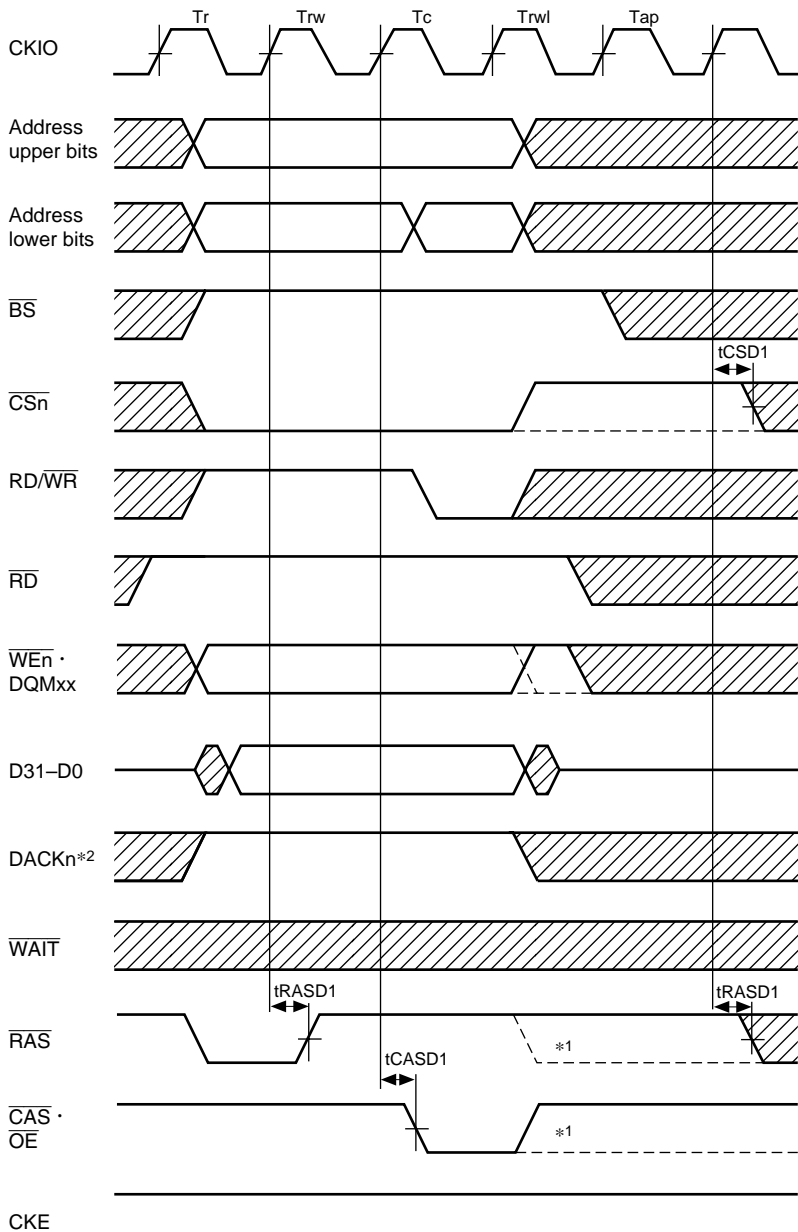

Figure 22.21 Synchronous DRAM Read Bus Cycle (Bank Active, Different Row Access, TRP = 2 Cycles, RCD = 1 Cycle, CAS Latency = 1 Cycle)



Notes: *1 Dotted line shows the case where synchronous DRAM in a different CS space is accessed.

*2 DACKn waveform when active-high is specified

Figure 22.23 Synchronous DRAM Write Bus Cycle
 (RASD = 0, RCD = 2 Cycles, TRWL = 2 Cycles)

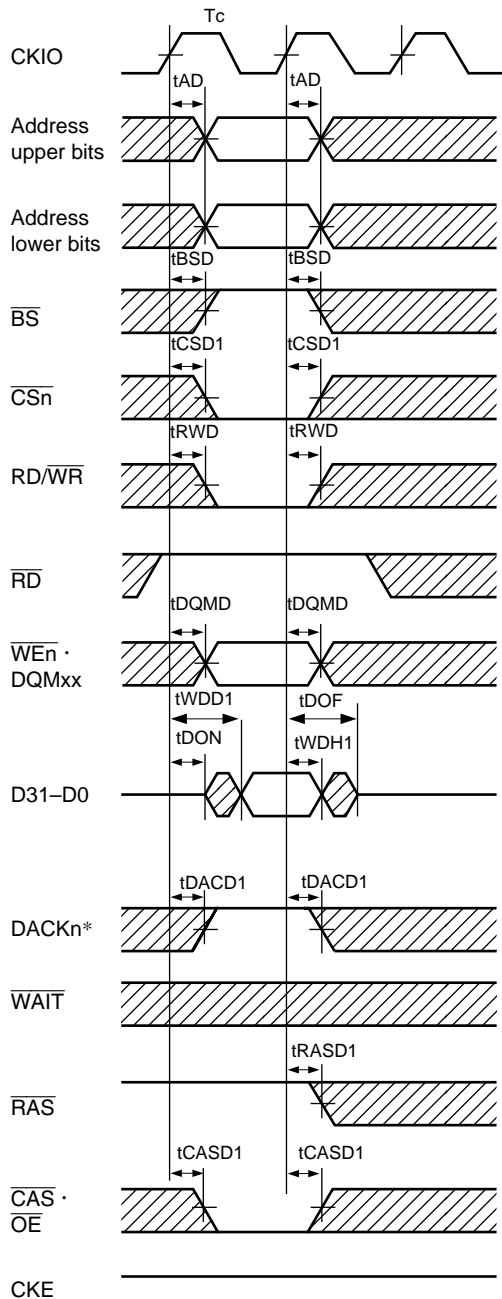

Note: * DACKn waveform when active-high is specified

**Figure 22.24 Synchronous DRAM Write Bus Cycle
(Bank Active, Same Row Access, $I\phi:E\phi$ other than 1:1)**

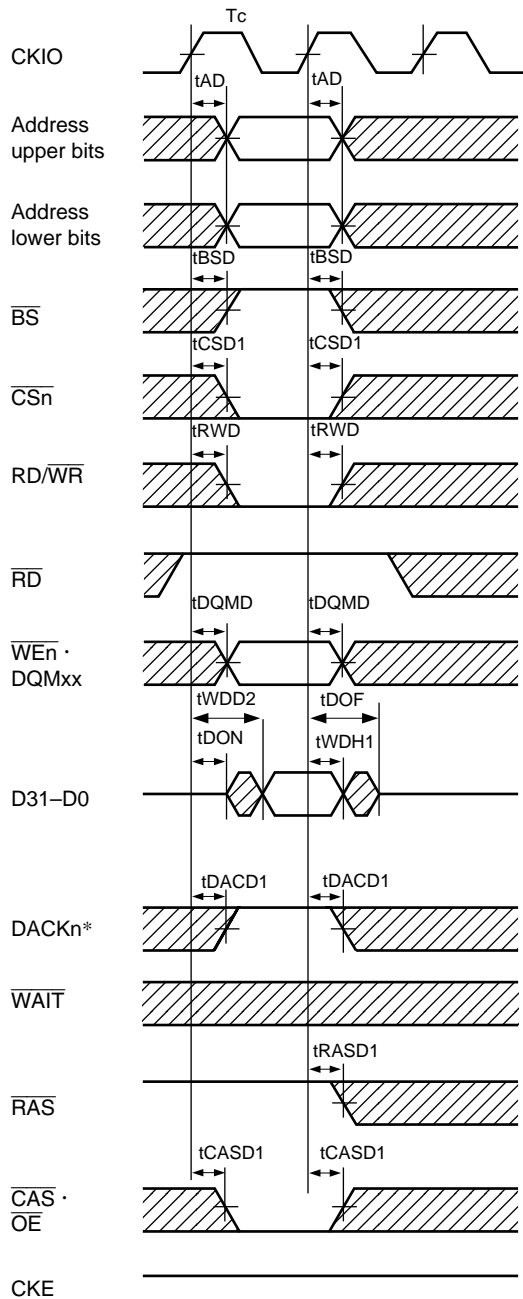

Note: * DACKn waveform when active-high is specified

**Figure 22.25 Synchronous DRAM Write Cycle
(Bank Active, Same Row Access, $I\phi:E\phi = 1:1$)**

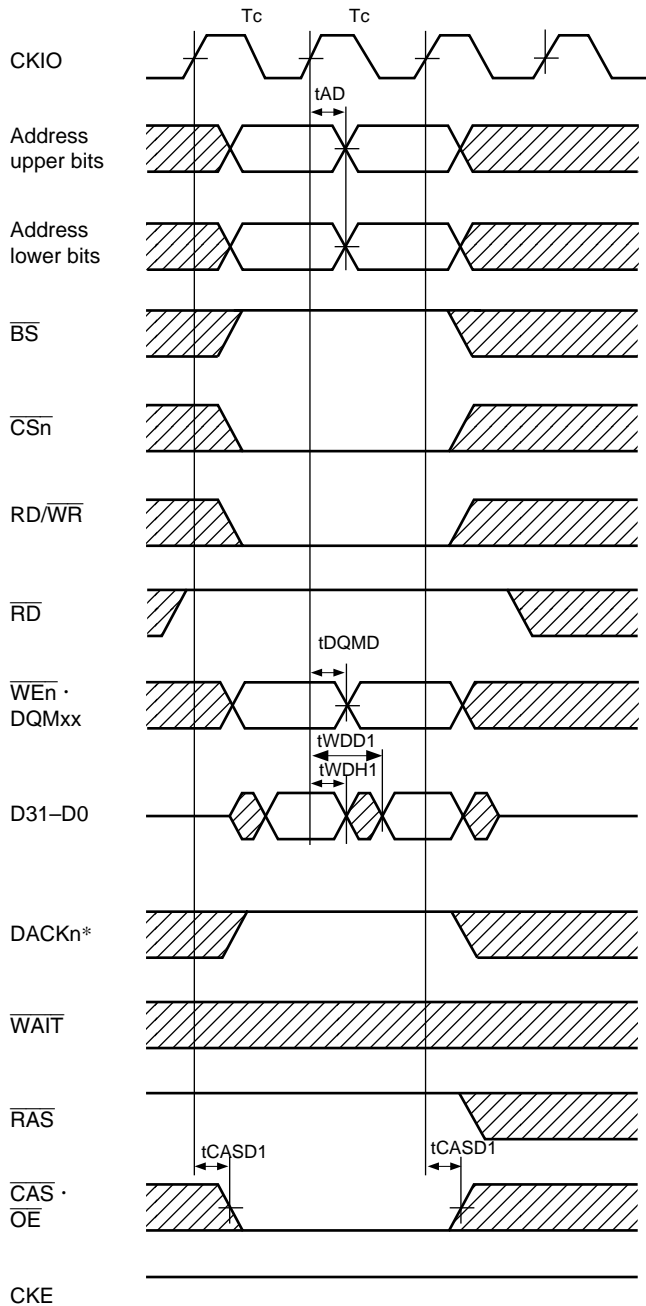

Note: * DACKn waveform when active-high is specified

**Figure 22.26 Synchronous DRAM Continuous Write Cycle
(Bank Active, Same Row Access, I ϕ :E ϕ other than 1:1)**

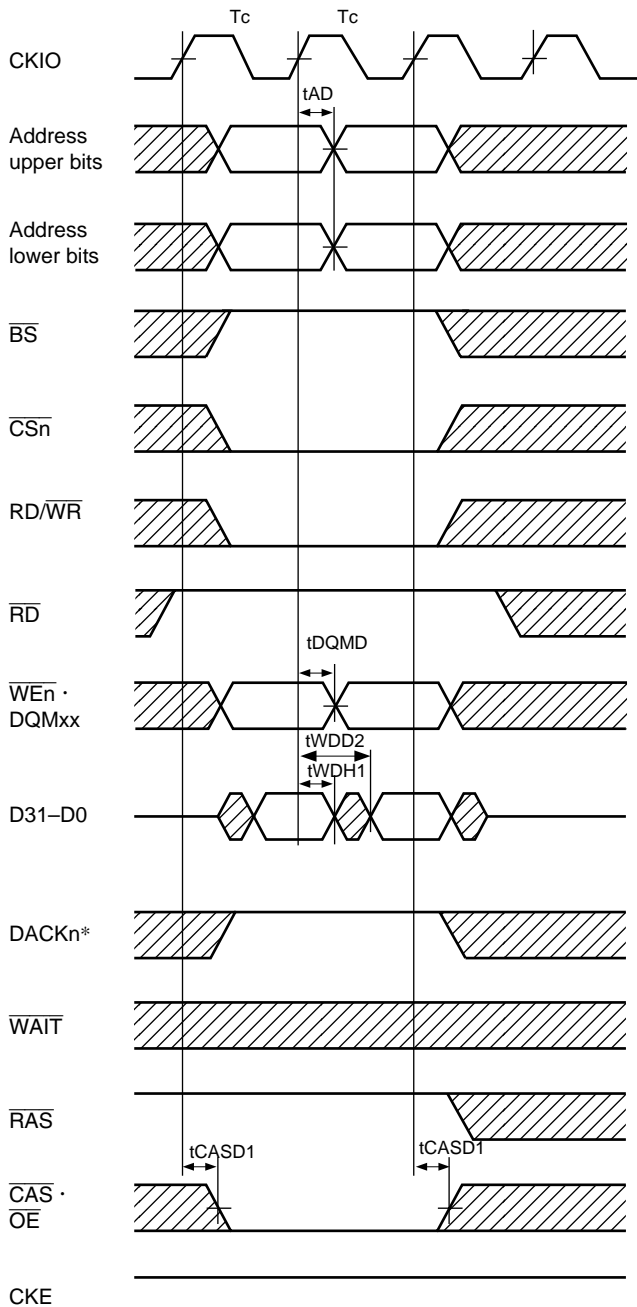

Note: * $DACKn$ waveform when active-high is specified

**Figure 22.27 Synchronous DRAM Continuous Write Cycle
(Bank Active, Same Row Access, $I\phi:E\phi = 1:1$)**

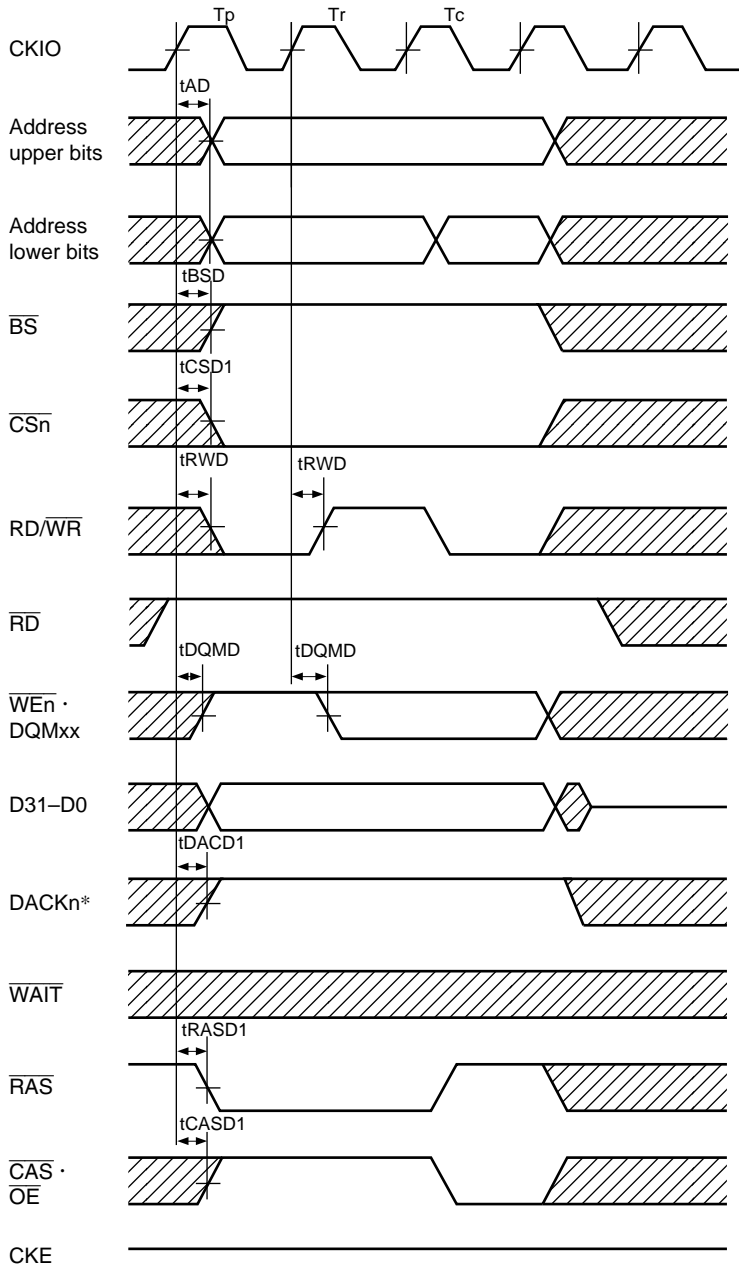

Note: * DACKn waveform when active-high is specified

Figure 22.28 Synchronous DRAM Write Bus Cycle
(Bank Active, Different Row Access, TRP = 1 Cycle, RCD = 1 Cycle)

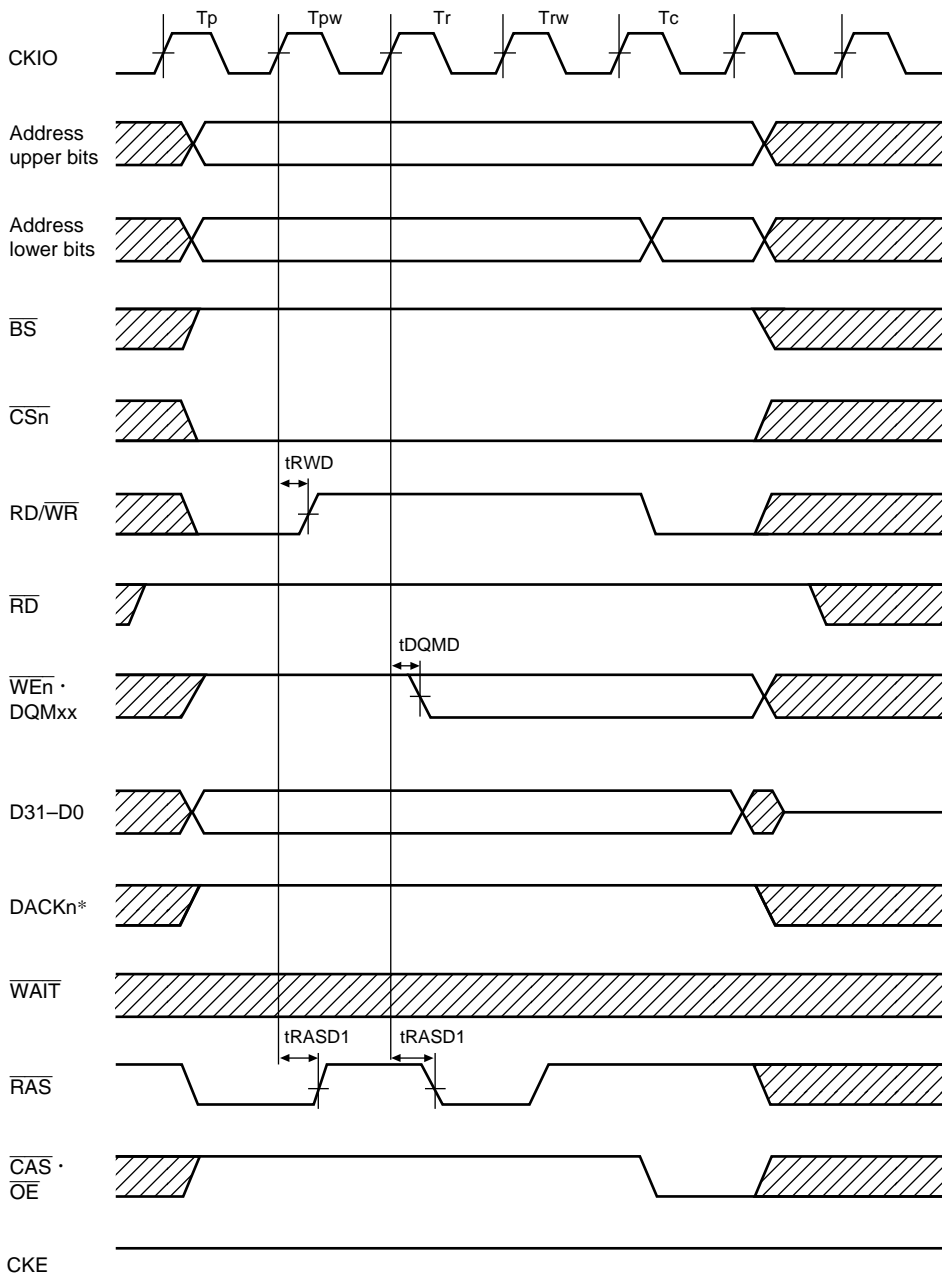

Note: * DACKn waveform when active-high is specified

Figure 22.29 Synchronous DRAM Write Bus Cycle
(Bank Active, Different Row Access, TRP = 2 Cycles, RCD = 2 Cycles)

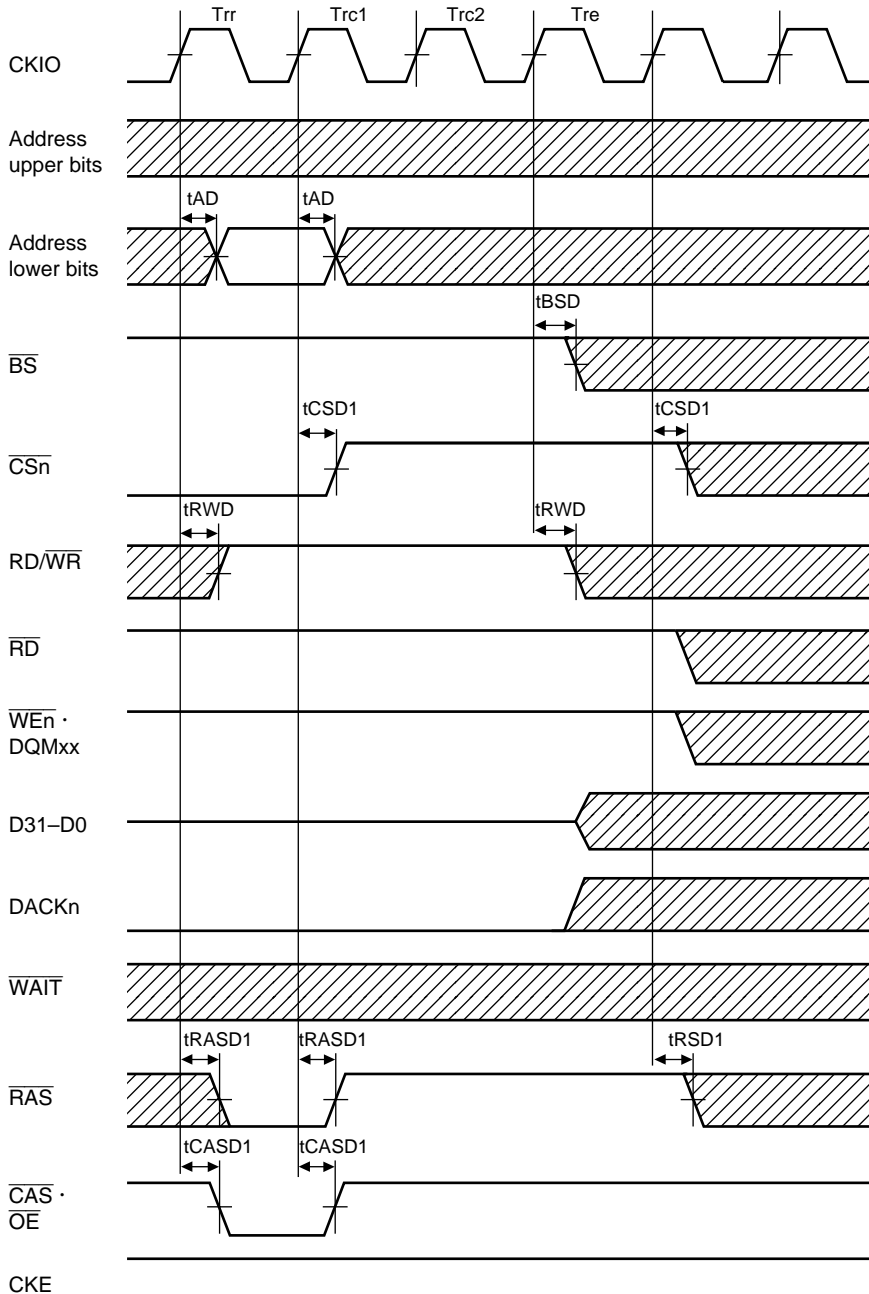

Note: An auto-refresh cycle is always preceded by a precharge cycle. The number of cycles between the two is determined by the number of cycles specified by TRP.

Figure 22.30 Synchronous DRAM Auto-Refresh Cycle
($T_{RAS} = 4$ Cycles)

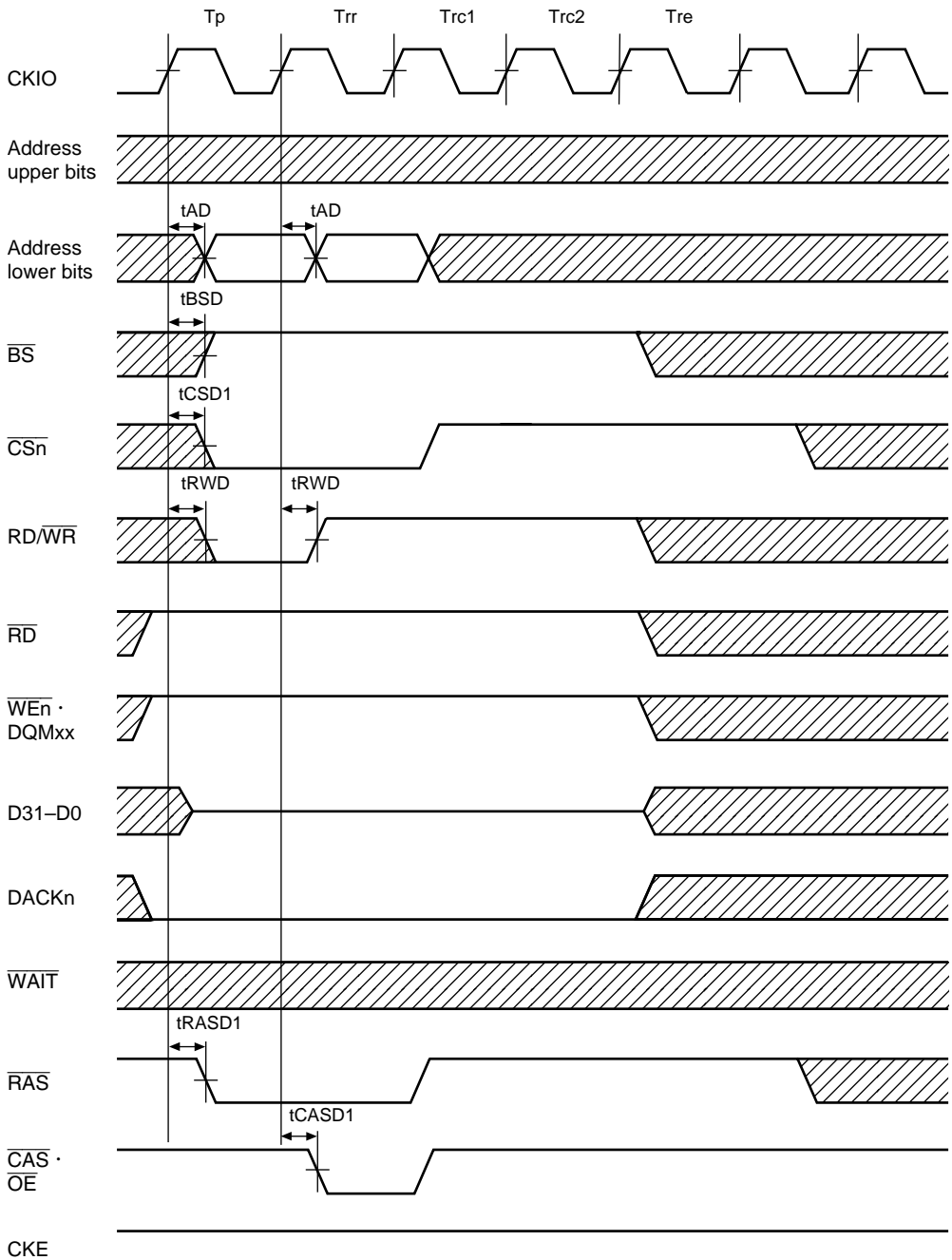
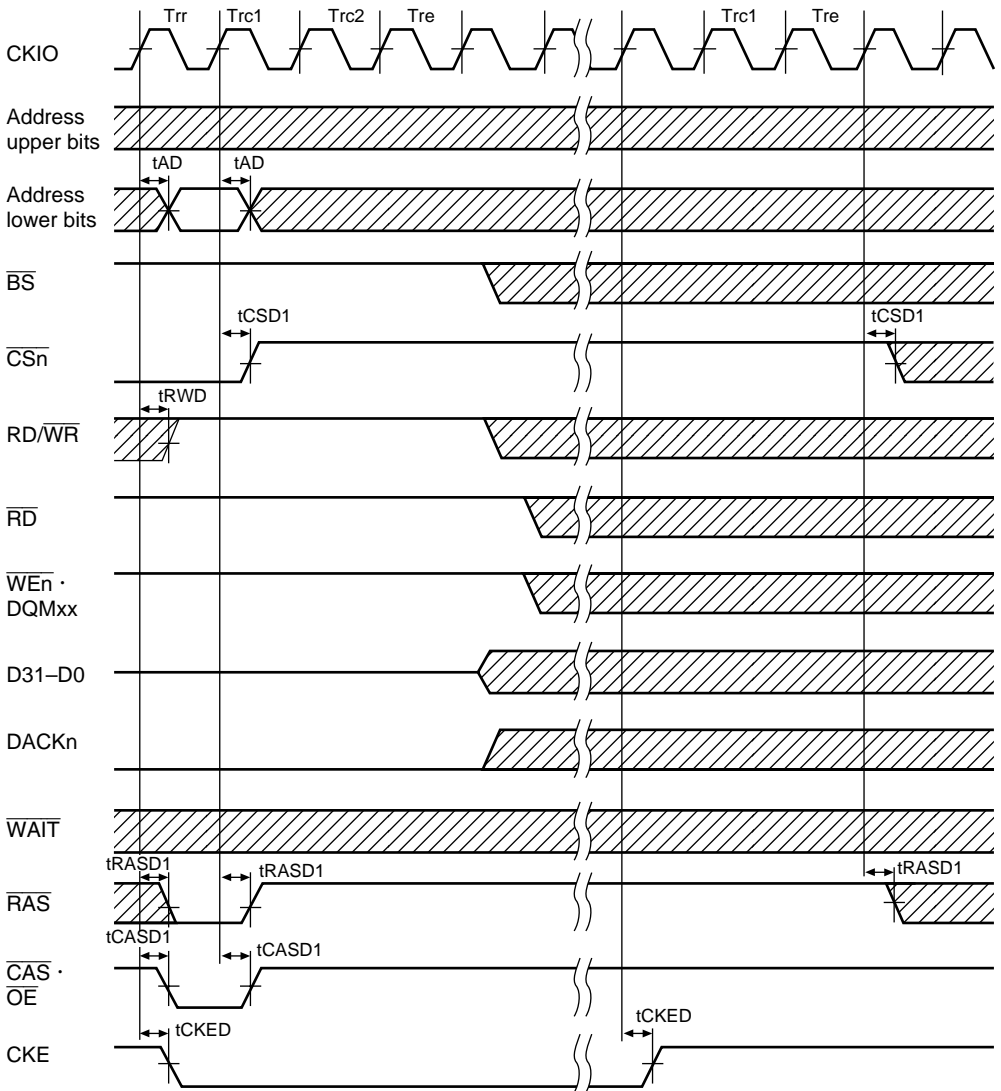
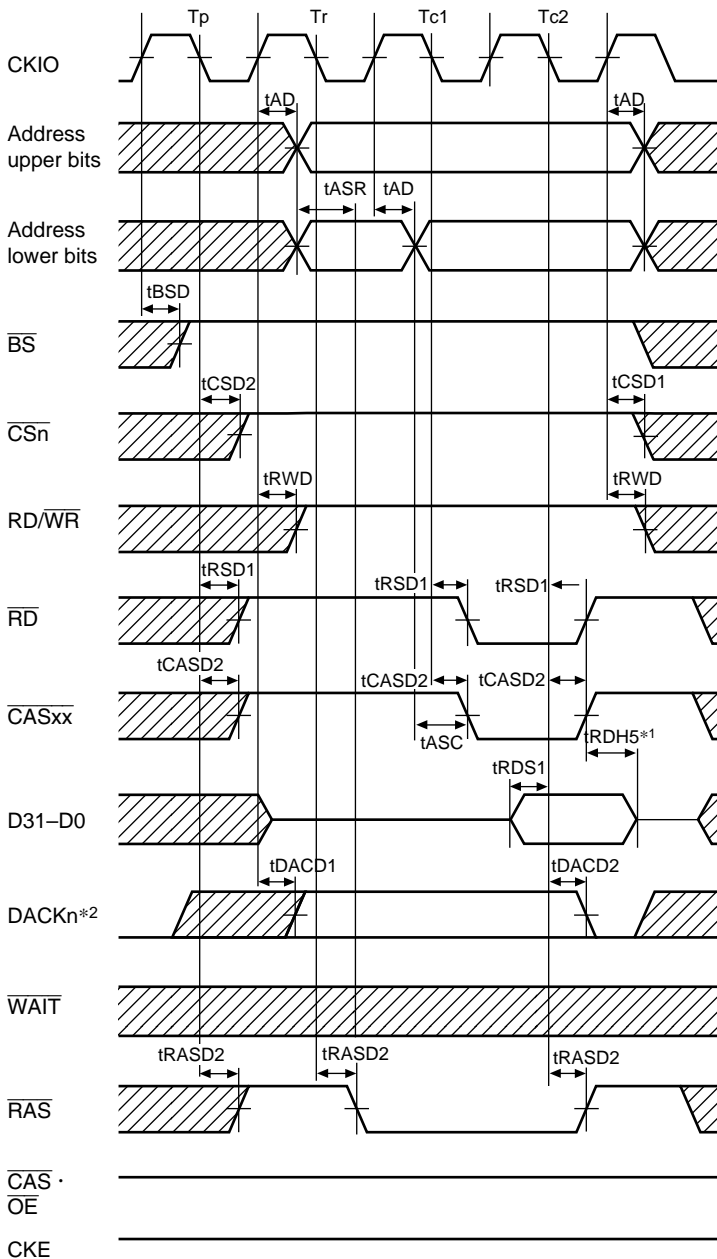

Figure 22.31 Synchronous DRAM Auto-Refresh Cycle
 (Shown from Precharge Cycle, $TRP = 1$ Cycle, $TRAS = 4$ Cycles)



Note: A self-refresh cycle is always preceded by a precharge cycle. The number of cycles between the two is determined by the number of cycles specified by TRP.

Figure 22.32 Synchronous DRAM Self-Refresh Cycle (TRAS = 3)



Notes: *1 t_{RDH5} is measured from the rise of \overline{RD} or \overline{CASxx} , whichever comes first.
 *2 $DACKn$ waveform when active-high is specified

Figure 22.33 DRAM Read Cycle
 (TRP = 1 Cycle, RCD = 1 Cycle, No Wait)

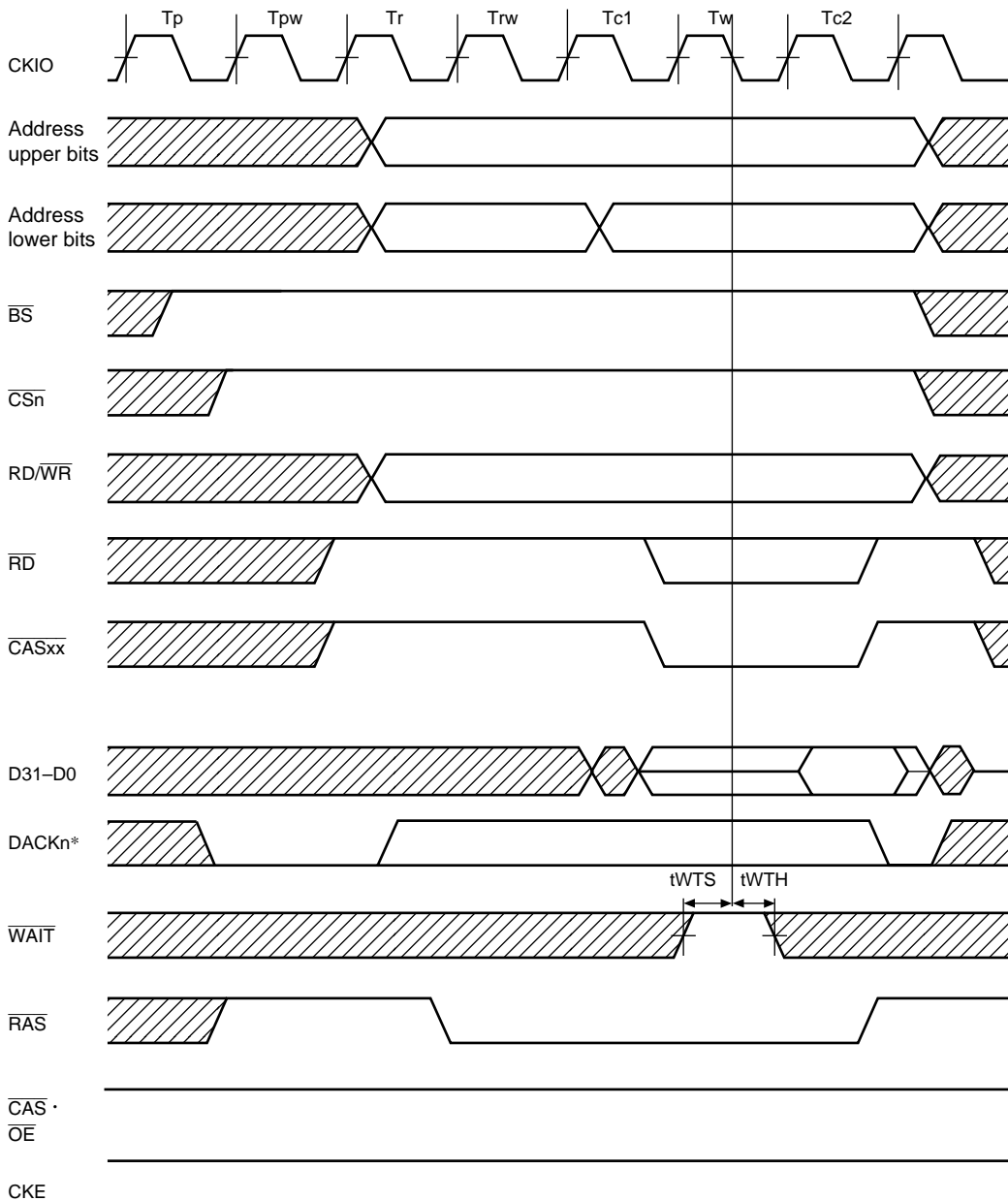

Note: * DACKn waveform when active-high is specified

Figure 22.35 DRAM Bus Cycle
 (TRP = 2 Cycles, RCD = 2 Cycles, 1 Wait)

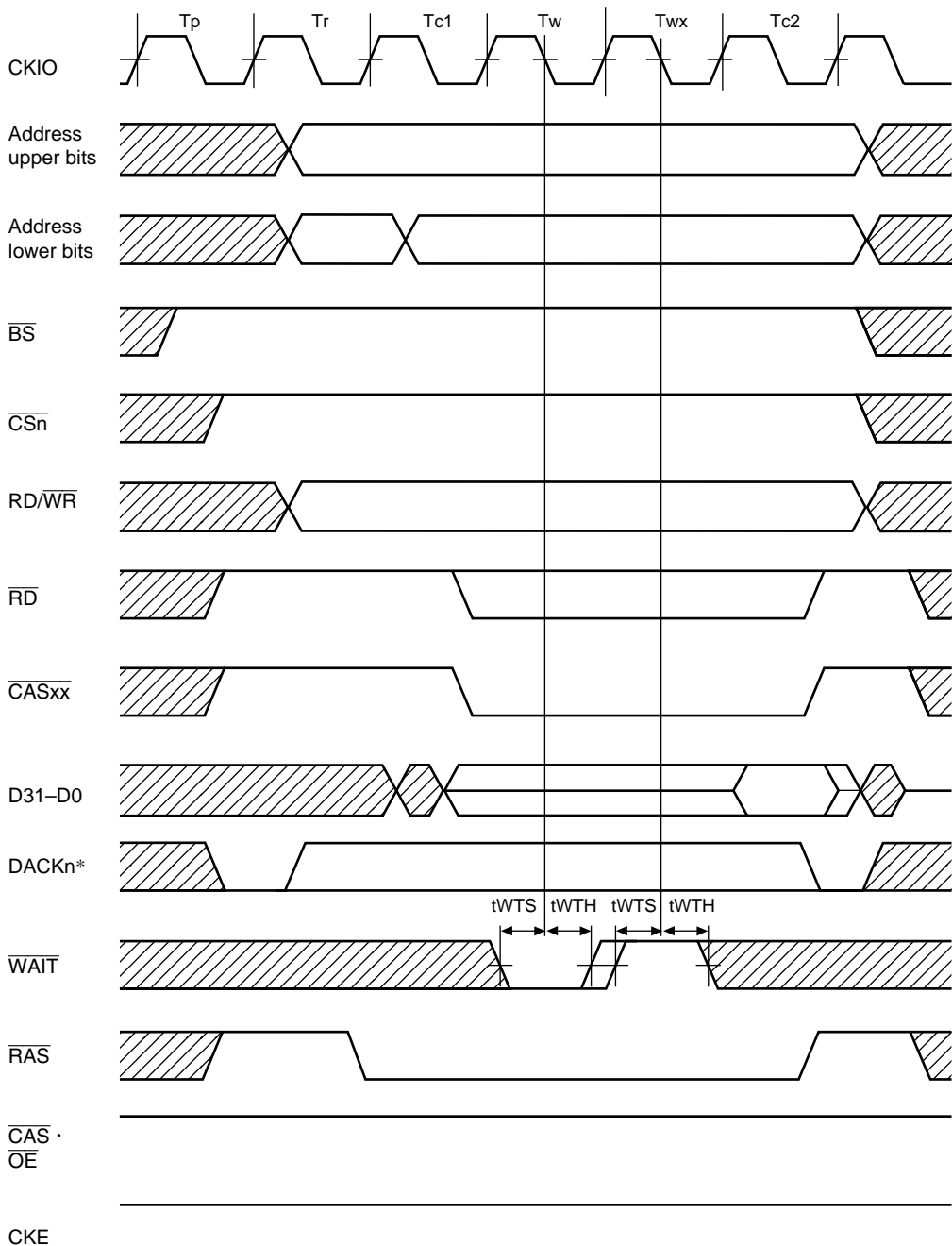

Note: * DACKn waveform when active-high is specified

Figure 22.36 DRAM Bus Cycle
 (TRP = 1 Cycle, RCD = 1 Cycle, External Wait Input)

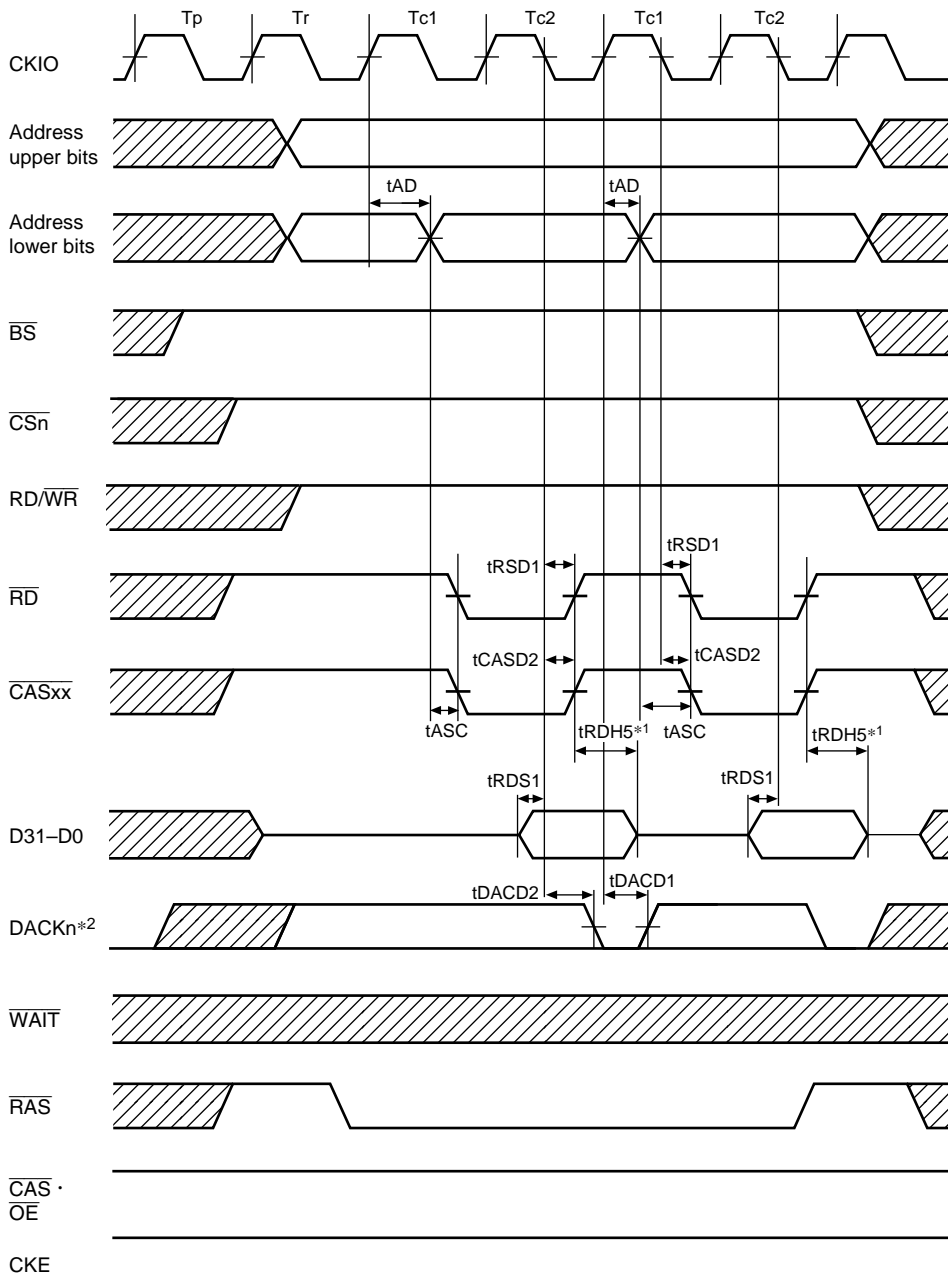

Notes: *1 t_{RDH5} is measured from the rise of \overline{RD} or \overline{CASxx} , whichever comes first.
 *2 DACKn waveform when active-high is specified

Figure 22.37 DRAM Burst Read Cycle
(TRP = 1 Cycle, RCD = 1 Cycle, No Wait)

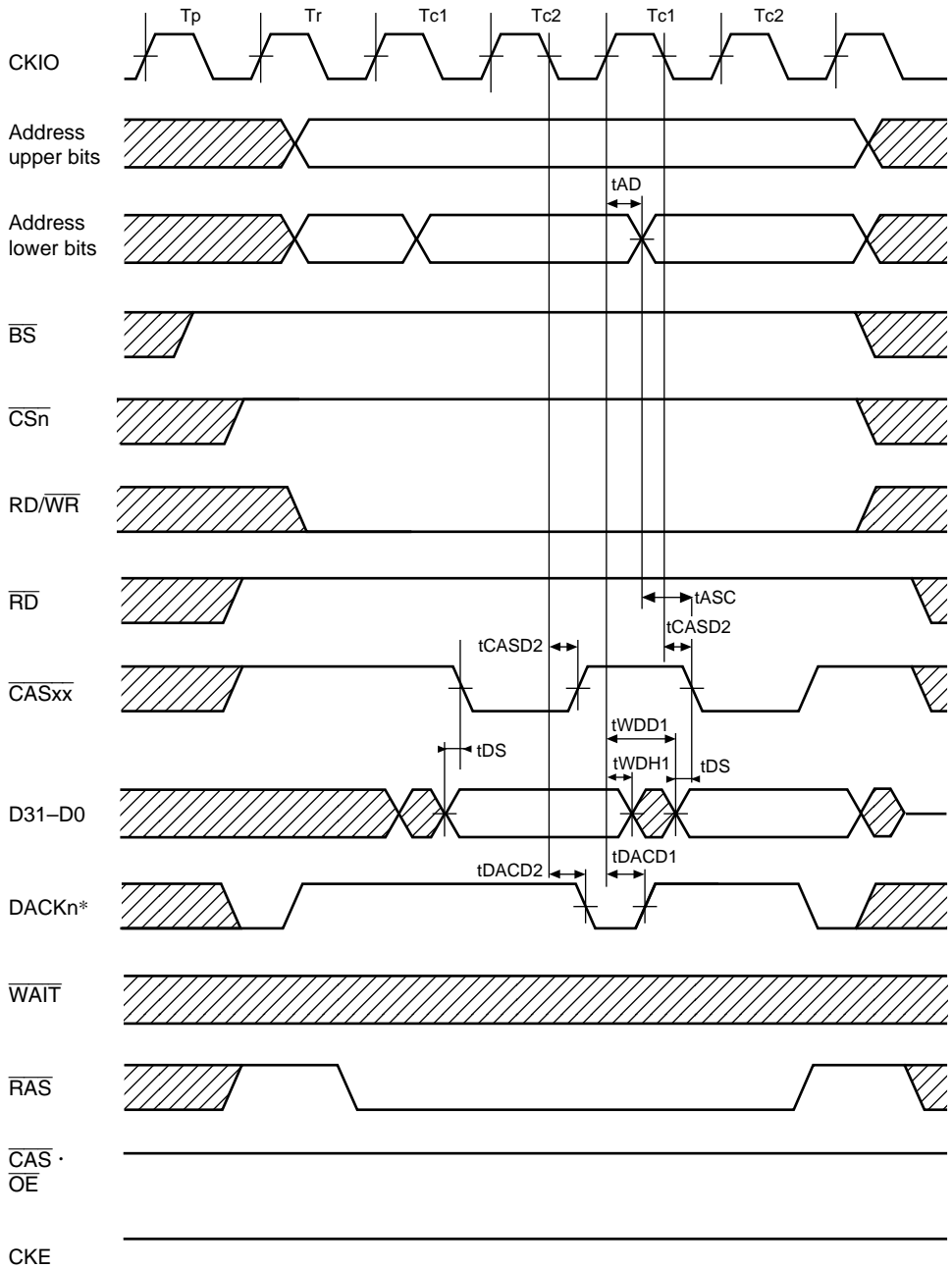

Note: * DACKn waveform when active-high is specified

Figure 22.38 DRAM Burst Write Cycle
(TRP = 1 Cycle, RCD = 1 Cycle, No Wait)

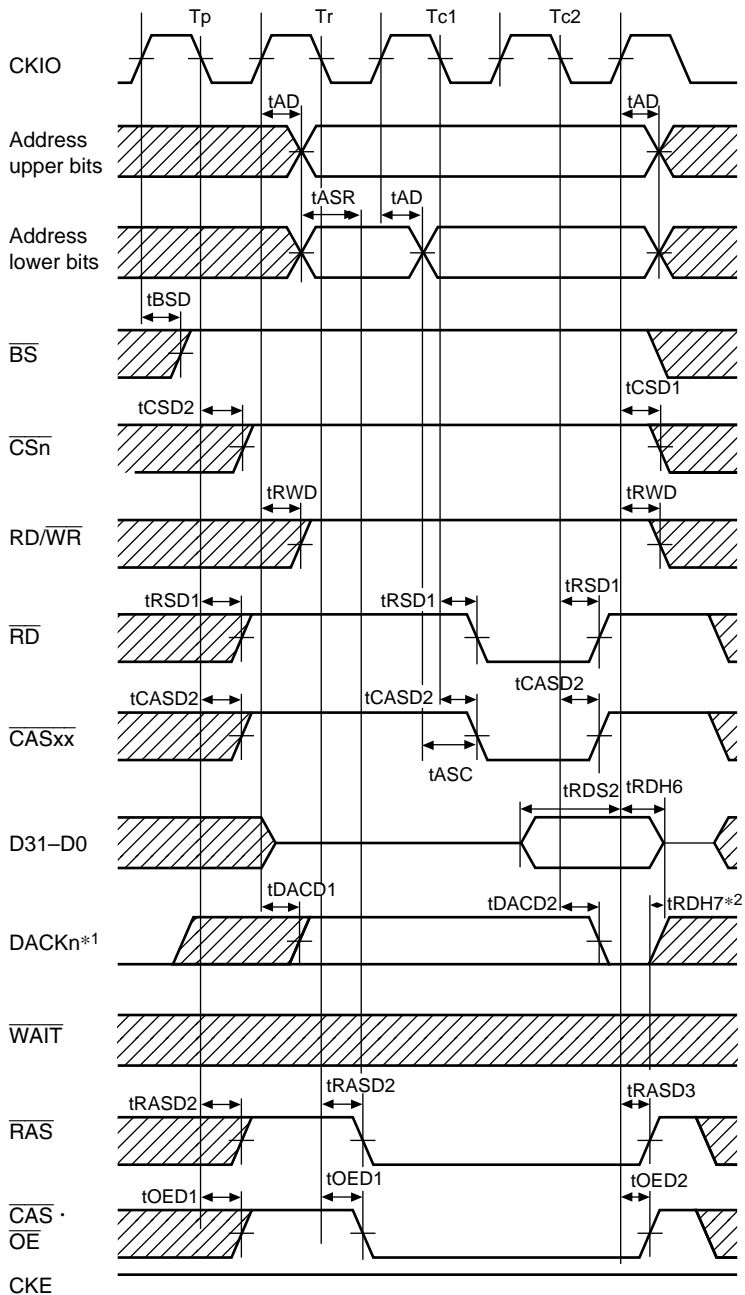

Notes: *1 DACKn waveform when active-high is specified

*2 t_{RDH7} is measured from the rise of RAS or $\overline{CAS} \cdot \overline{OE}$, whichever comes first.

Figure 22.39 EDO Read Cycle
(TRP = 1 Cycle, RCD = 1 Cycle, No Wait)

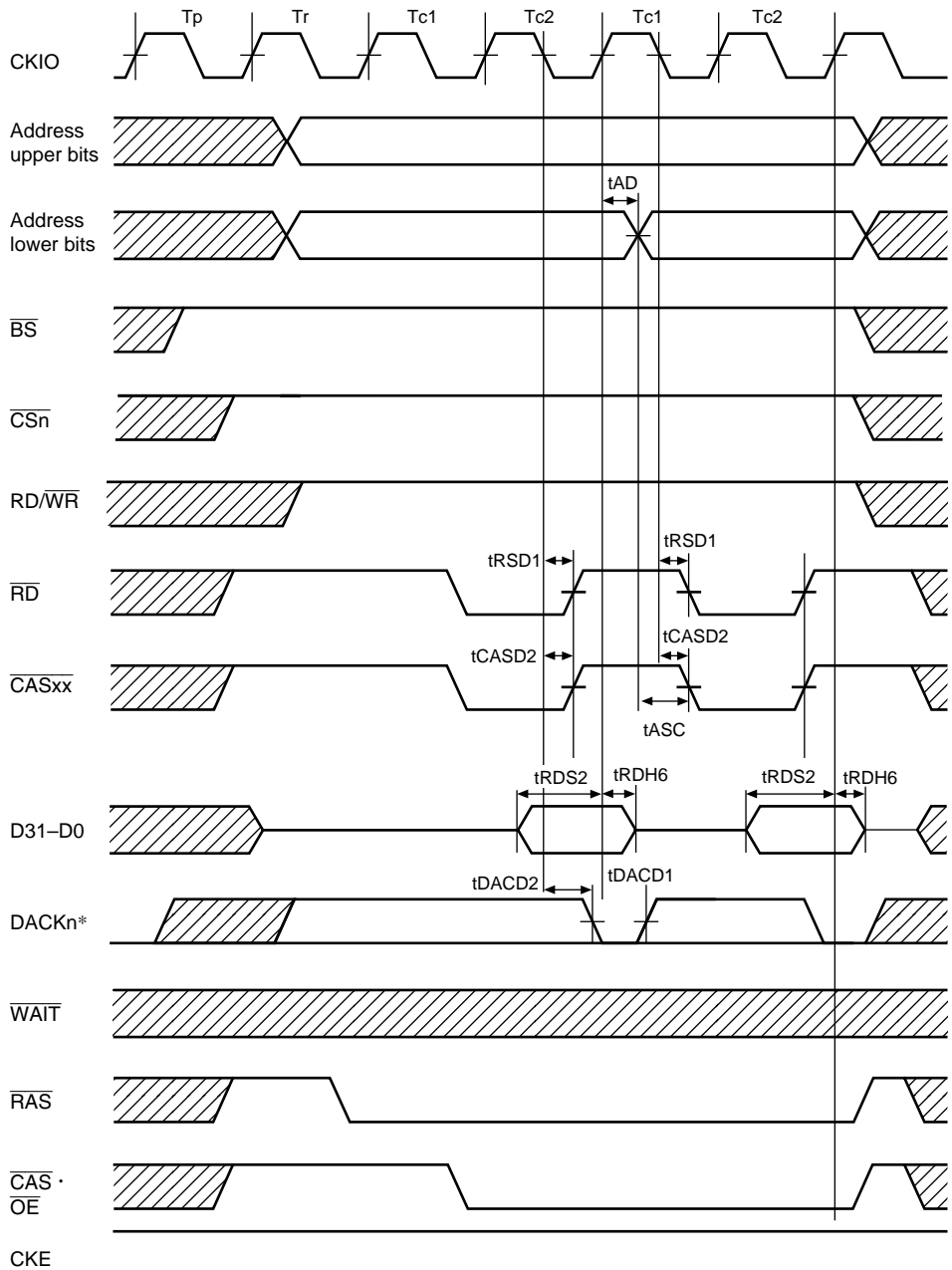

Note: * DACKn waveform when active-high is specified

Figure 22.40 EDO Burst Read Cycle
(TRP = 1 Cycle, RCD = 1 Cycle, No Wait)

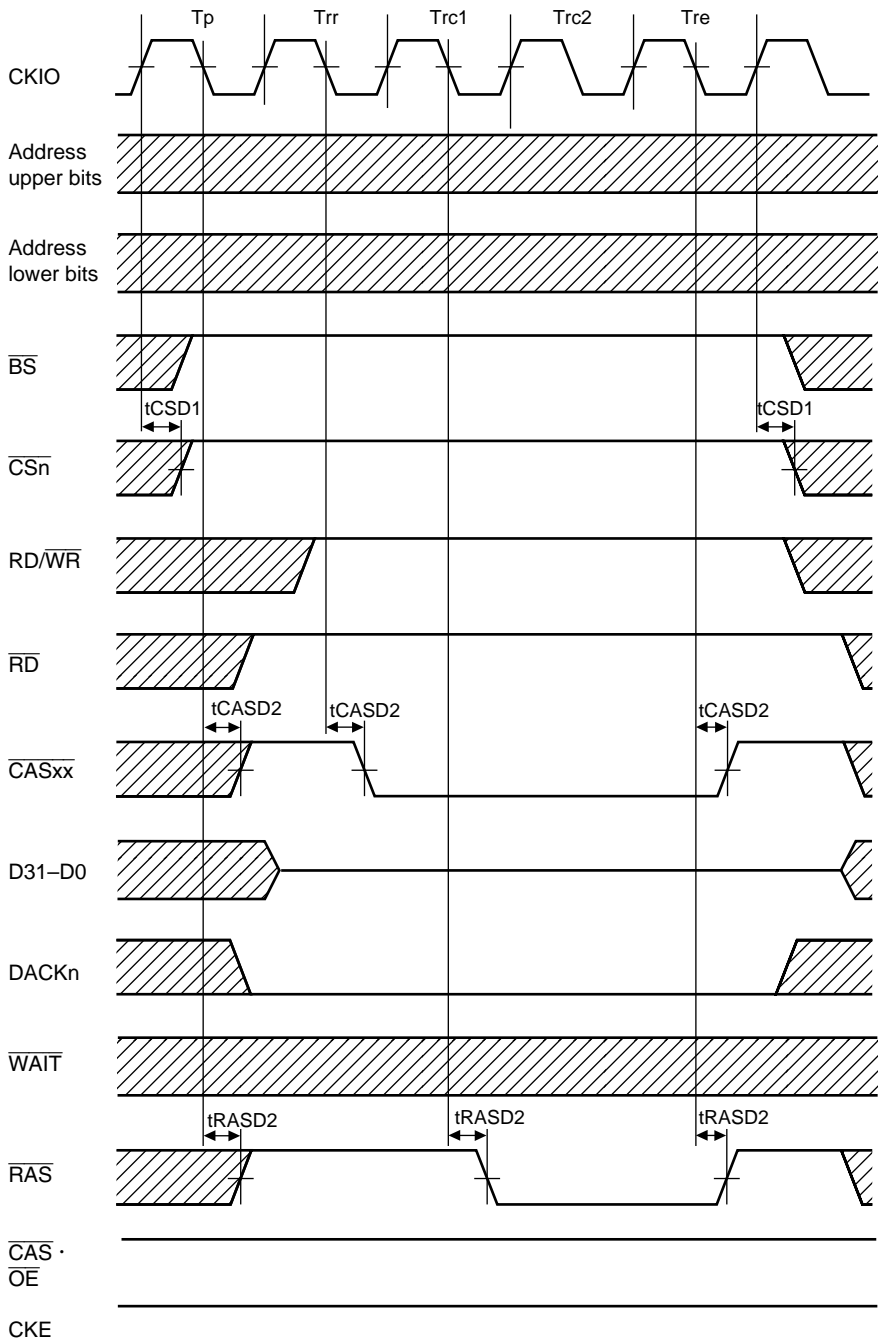

**Figure 22.41 DRAM $\overline{\text{CAS}}$ -Before- $\overline{\text{RAS}}$ Refresh Cycle
(TRP = 1 Cycle, TRAS = 2 Cycles)**

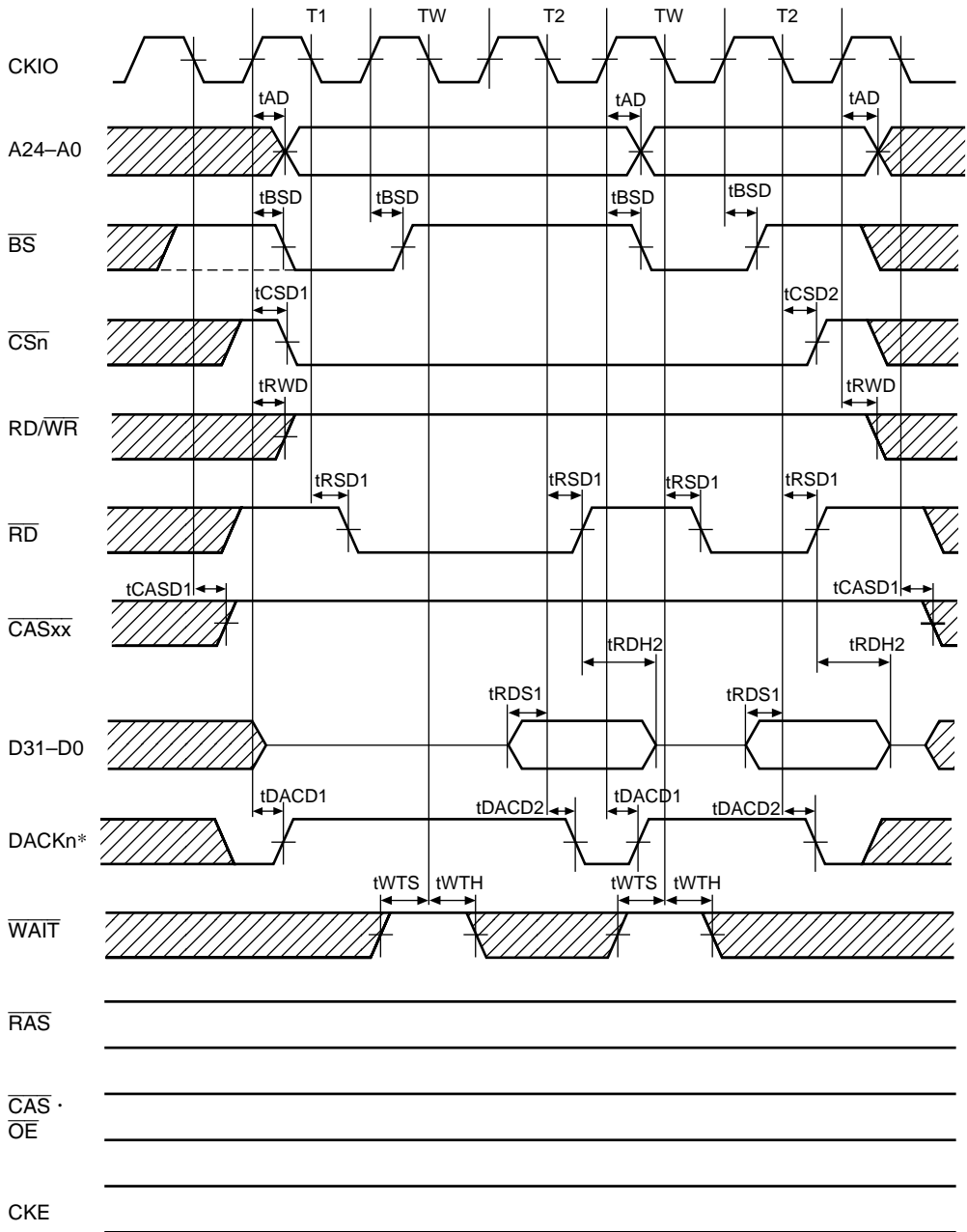

Note: * DACKn waveform when active-high is specified

**Figure 22.42 Burst ROM Read Cycle
(Wait = 1)**

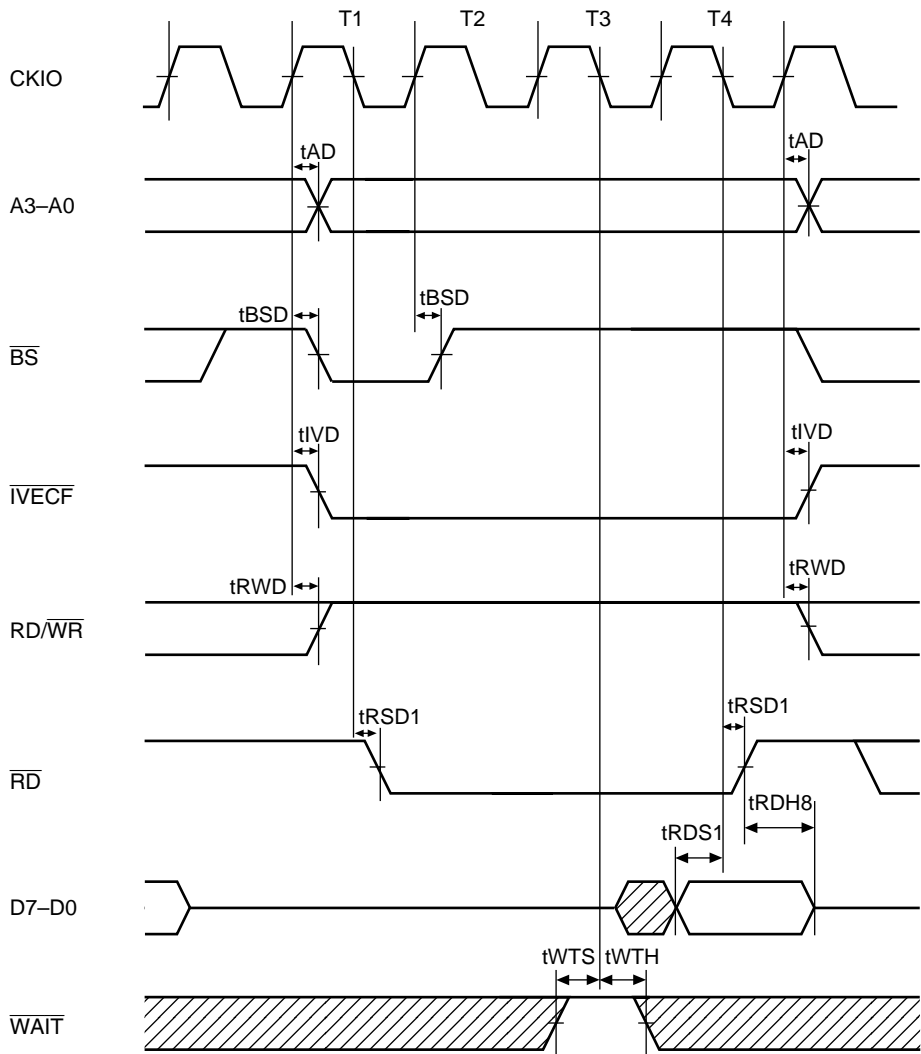
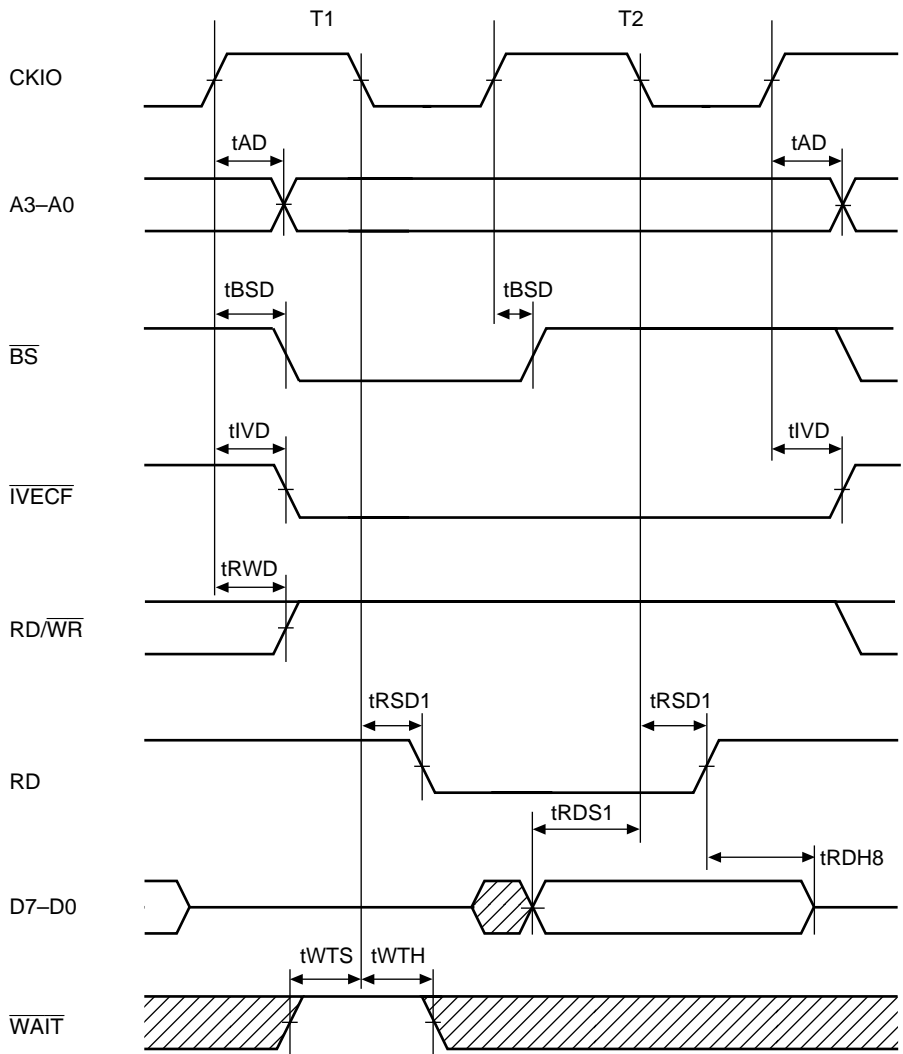
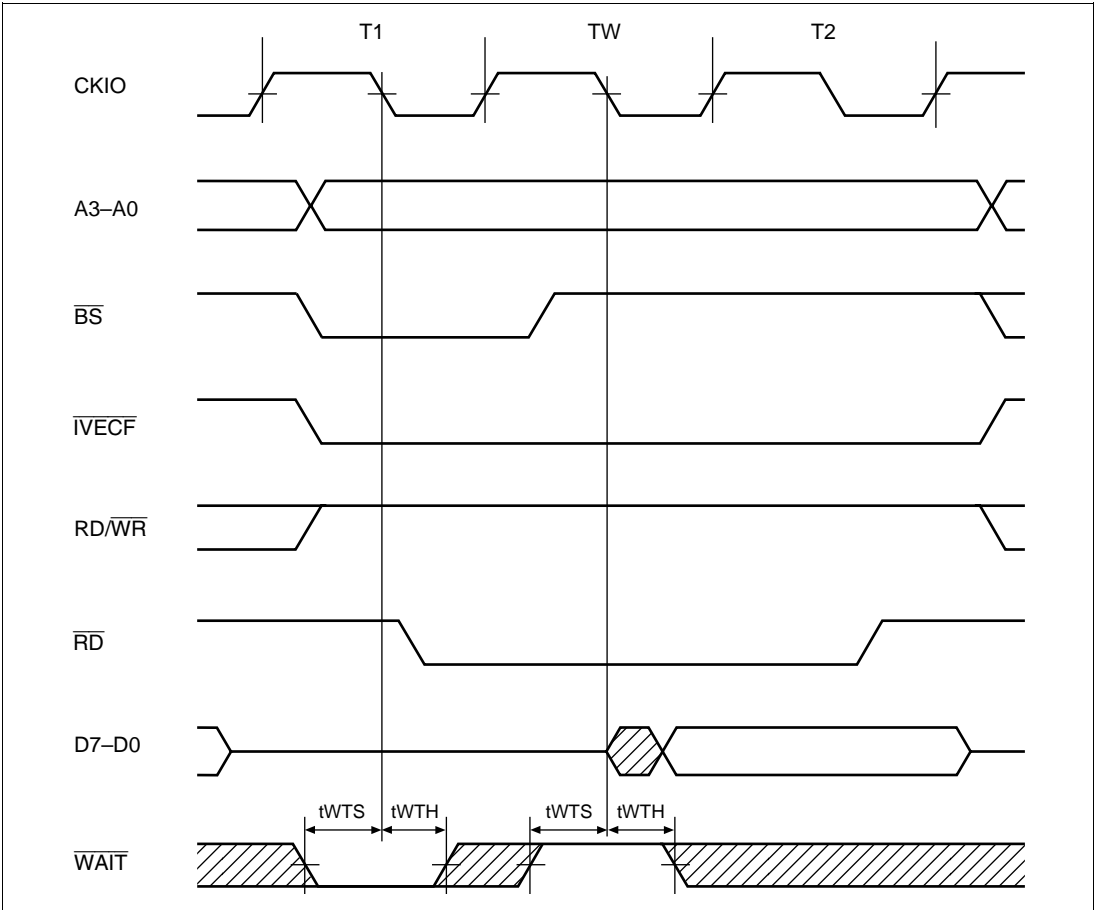

Figure 22.43 Interrupt Vector Fetch Cycle
 (No Wait, $I\phi:E\phi = 1:1$)



**Figure 22.44 Interrupt Vector Fetch Cycle
(No Wait, I ϕ :E ϕ other than 1:1)**



**Figure 22.45 Interrupt Vector Fetch Cycle
(External Wait Input, $I\phi:E\phi$ other than 1:1)**

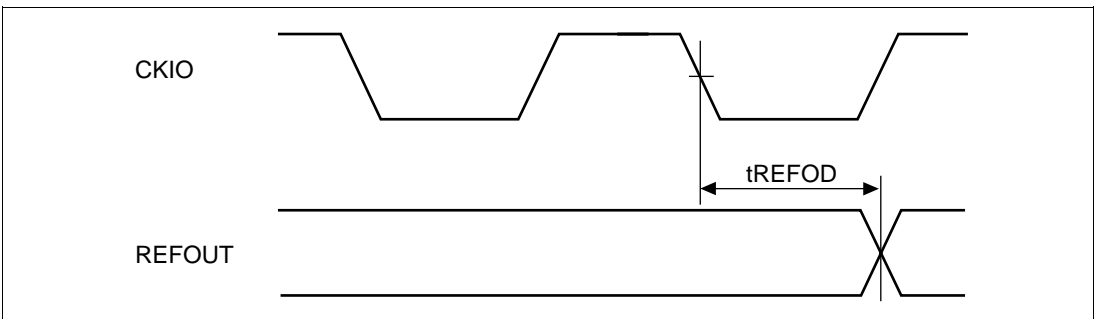

Figure 22.46 REFOUT Delay Time

22.3.4 Direct Memory Access Controller Timing

Table 22.8 Direct Memory Access Controller Timing

Conditions: $V_{CC} = PLLV_{CC} = 3.3\text{ V} \pm 0.3\text{ V}$, $PV_{CC} = 5.0\text{ V} \pm 0.5\text{ V}/3.3\text{ V} \pm 0.3\text{ V}$, $PV_{CC} \geq V_{CC}$,
 $V_{SS} = PV_{SS} = PLLV_{SS} = 0\text{ V}$, $T_a = -20\text{ to }+75^\circ\text{C}$

Item	Symbol	Min	Max	Unit	Figure
DREQ0, DREQ1 setup time	tDRQS	10	—	ns	22.47
DREQ0, DREQ1 hold time	tDRQH	5	—	ns	

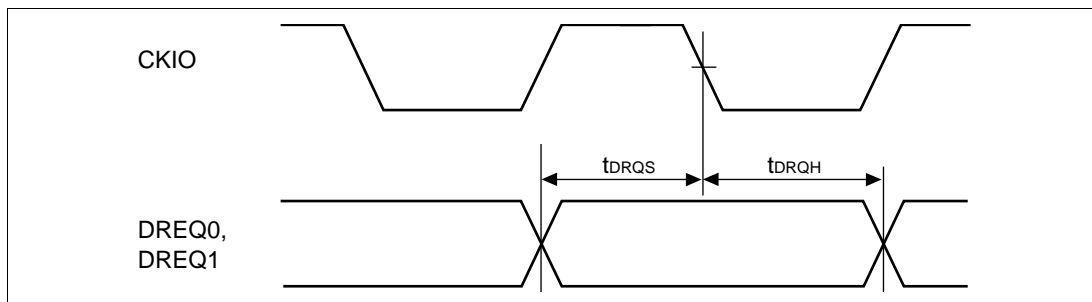

Figure 22.47 DREQ0, DREQ1 Input Timing

22.3.5 Free-Running Timer Timing

Table 22.9 Free-Running Timer Timing

Conditions: $V_{CC} = PLLV_{CC} = 3.3 \text{ V} \pm 0.3 \text{ V}$, $PV_{CC} = 5.0 \text{ V} \pm 0.5 \text{ V} / 3.3 \text{ V} \pm 0.3 \text{ V}$, $PV_{CC} \geq V_{CC}$,
 $V_{SS} = PV_{SS} = PLLV_{SS} = 0 \text{ V}$, $T_a = -20 \text{ to } +75^\circ\text{C}$

Item	Symbol	Min	Max	Unit	Figure
Output compare output delay time	tFOCD	—	100	ns	22.48, 22.49
Input capture input setup time (tE _{cyc} :tP _{cyc} = 1:1)	tFICS	50	—	ns	22.48
Input capture input setup time (tE _{cyc} :tP _{cyc} = 1:2)	tFICS	t _{cyc} + 50	—	ns	22.49
Input capture input setup time (tE _{cyc} :tP _{cyc} = 1:4)	tFICS	3t _{cyc} + 50	—	ns	22.49
Input capture input hold time	tFICH	50	—	ns	22.48, 22.49
Timer clock input setup time (tE _{cyc} :tP _{cyc} = 1:1)	tFCKS	50	—	ns	22.50
Timer clock input setup time (tE _{cyc} :tP _{cyc} = 1:2)	tFCKS	t _{cyc} + 50	—	ns	22.51
Timer clock input setup time (tE _{cyc} :tP _{cyc} = 1:4)	tFCKS	3t _{cyc} + 50	—	ns	22.51
Timer clock pulse width (single edge specified)	tFCKWH	4.5	—	tP _{cyc}	22.50, 22.51
Timer clock pulse width (both edges specified)	tFCKWL	8.5	—	tP _{cyc}	

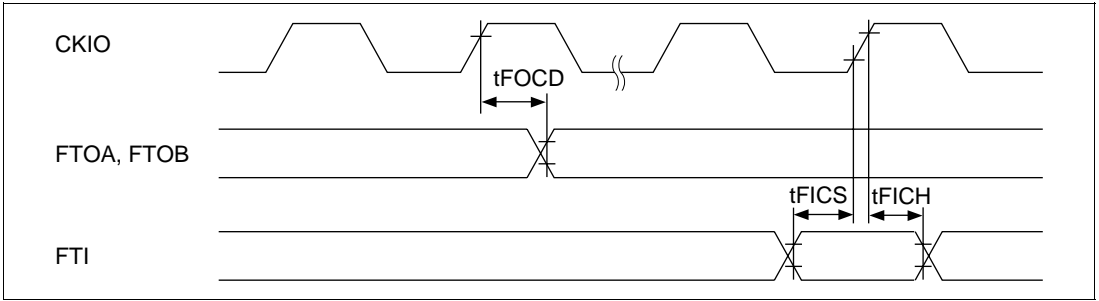

Figure 22.48 FRT Input/Output Timing ($t_{Ecyc}:t_{Pcyc} = 1:1$)

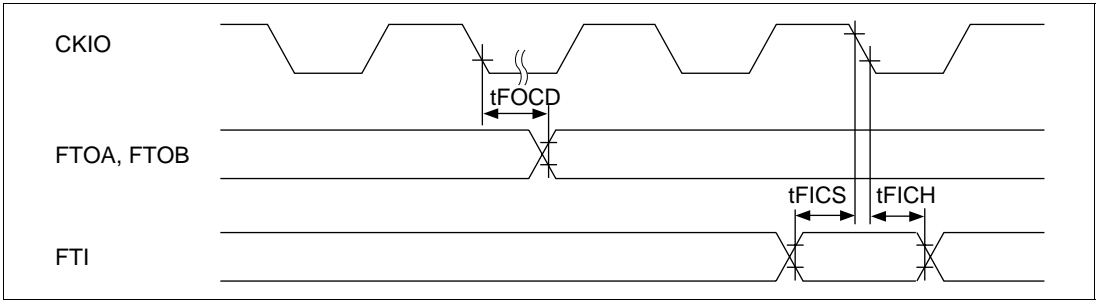

Figure 22.49 FRT Input/Output Timing ($t_{Ecyc}:t_{Pcyc}$ other than 1:1)

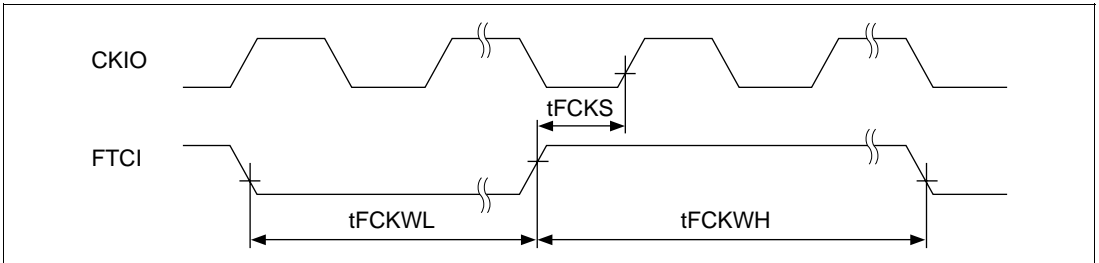

Figure 22.50 FRT Clock Input Timing ($t_{Ecyc}:t_{Pcyc} = 1:1$)

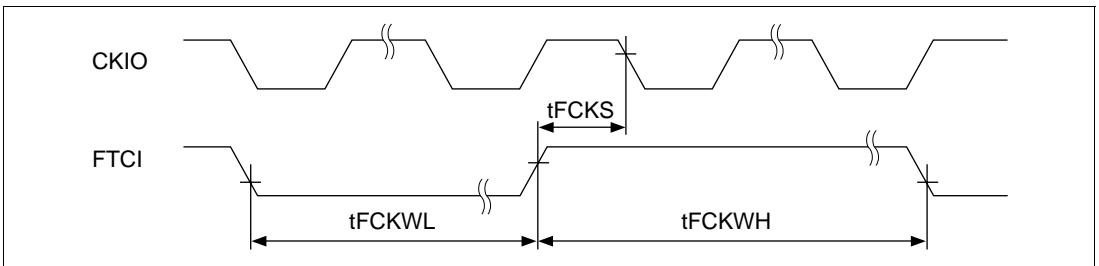

Figure 22.51 FRT Clock Input Timing ($t_{Ecyc}:t_{Pcyc}$ other than 1:1)

22.3.6 Serial Communication Interface Timing

Table 22.10 Serial Communication Interface Timing

Conditions: $V_{CC} = PLLV_{CC} = 3.3\text{ V} \pm 0.3\text{ V}$, $PV_{CC} = 5.0\text{ V} \pm 0.5\text{ V}/3.3\text{ V} \pm 0.3\text{ V}$, $PV_{CC} \geq V_{CC}$,
 $V_{SS} = PV_{SS} = PLLV_{SS} = 0\text{ V}$, $T_a = -20\text{ to }+75^\circ\text{C}$

Item	Symbol	Min	Max	Unit	Figure
Input clock cycle	tscyc	4	—	tPcyc	22.52
Input clock cycle (synchronous mode)	tscyc	6	—	tPcyc	22.53
Input clock pulse width	tSCKW	0.4	0.6	tcscyc	22.52
Transmit data delay time (synchronous mode)	tTXD	—	100	ns	22.53
Receive data setup time (synchronous mode)	tRXS	100	—	ns	
Receive data hold time (synchronous mode)	tRXH	100	—	ns	
$\overline{\text{RTS}}$ delay time	tRTSD	—	100	ns	22.54
$\overline{\text{CTS}}$ setup time (synchronous mode)	tCTSS	100	—	ns	
$\overline{\text{CTS}}$ hold time (synchronous mode)	tCTSH	100	—	ns	

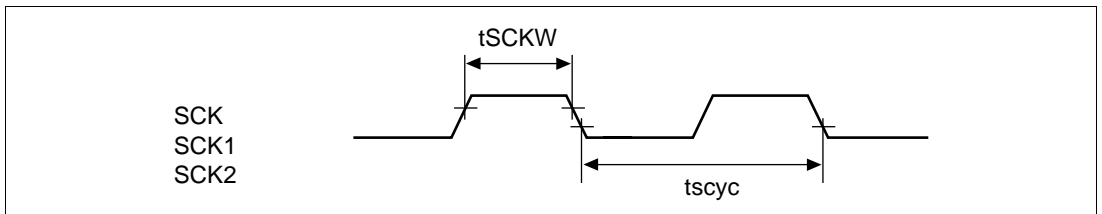

Figure 22.52 Input Clock Input/Output Timing

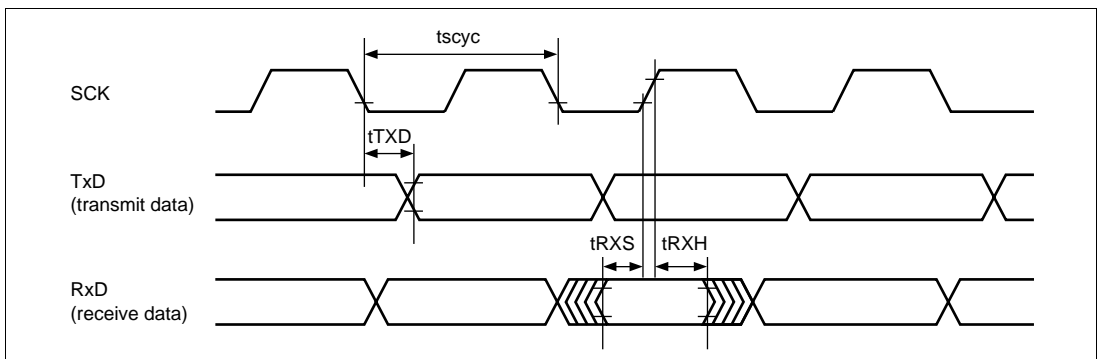

Figure 22.53 SCI Input/Output Timing (Synchronous Mode)

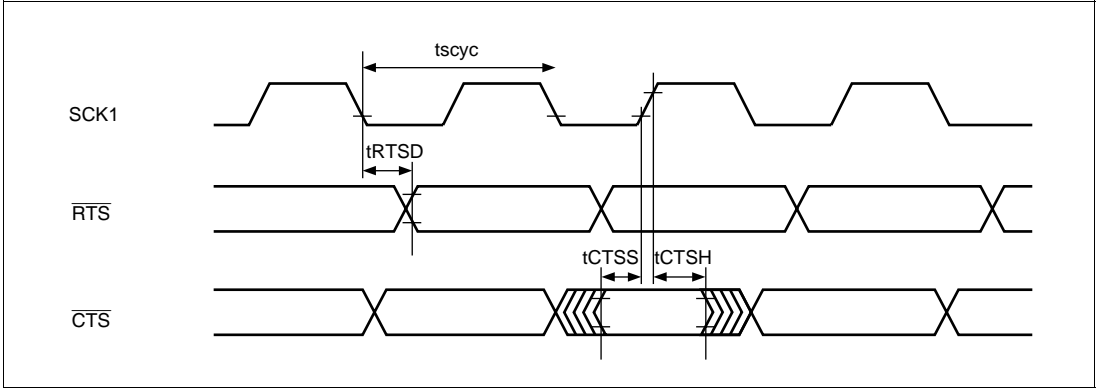

Figure 22.54 $\overline{\text{RTS}}$ and $\overline{\text{CTS}}$ Input/Output Timing

Table 22.11 16-Bit Timer-Pulse Unit

Conditions: $V_{CC} = \text{PLL}V_{CC} = 3.3 \text{ V} \pm 0.3 \text{ V}$, $\text{PV}_{CC} = 5.0 \text{ V} \pm 0.5 \text{ V}/3.3 \text{ V} \pm 0.3 \text{ V}$, $\text{PV}_{CC} \geq V_{CC}$,
 $V_{SS} = \text{PLL}V_{SS} = 0 \text{ V}$, $T_a = -20 \text{ to } +75^\circ\text{C}$

Item		Symbol	Min	Max	Unit	Figure
Timer output delay time		tTOCD	—	100	ns	22.55, 22.56
Timer input setup time (tEcyc:tPcyc = 1:1)		tTICS	50	—	ns	
Timer input setup time (tEcyc:tPcyc = 1:2)		tTICS	tcyc + 50	—	ns	22.55, 22.56
Timer input setup time (tEcyc:tPcyc = 1:4)		tTICS	3tcyc + 50	—	ns	
Timer clock input setup time (tEcyc:tPcyc = 1:1)		tTCKS	50	—	ns	22.57
Timer clock input setup time (tEcyc:tPcyc = 1:2)		tTCKS	tcyc + 50	—	ns	
Timer clock input setup time (tEcyc:tPcyc = 1:4)		tTCKS	3tcyc + 50	—	ns	
Timer clock pulse width	Single edge specified	tTCKWH	1.5	—	tcyc	
	Both edges specified	tTCKWL	2.5	—		

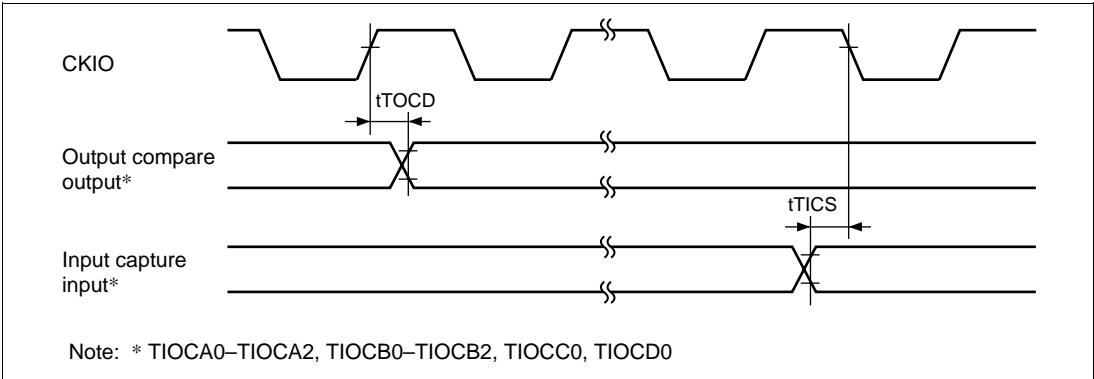

Figure 22.55 TPU Input/Output Timing ($t_{Ecyc}:t_{Pcyc} = 1:1$)

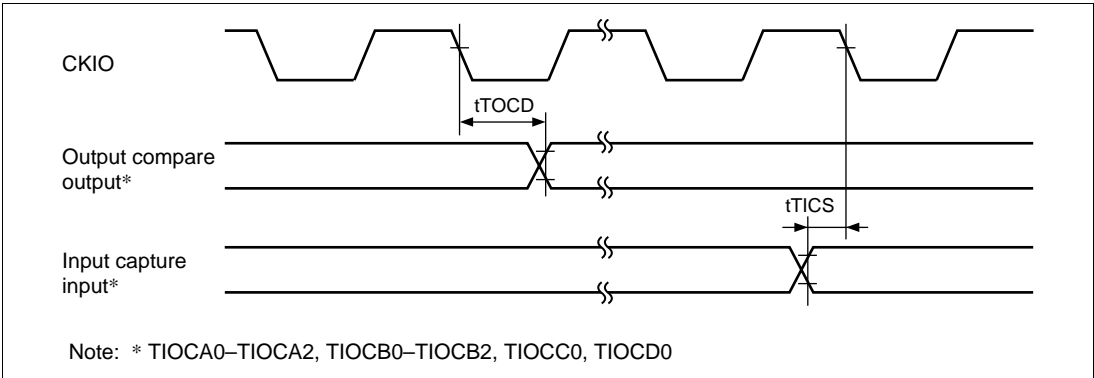

Figure 22.56 TPU Input/Output Timing ($t_{Ecyc}:t_{Pcyc}$ other than 1:1)

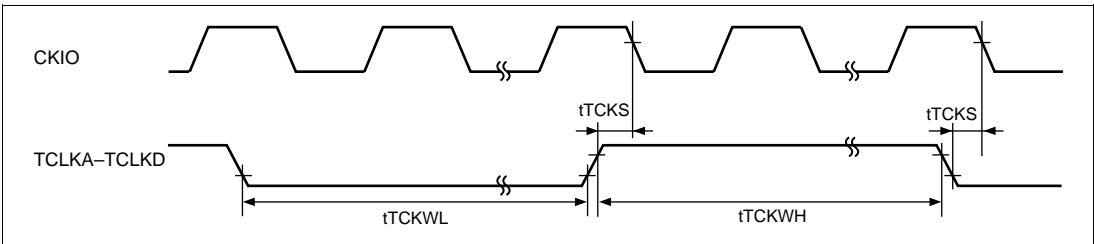

Figure 22.57 TPU Clock Input Timing

22.3.7 Watchdog Timer Timing

Table 22.12 Watchdog Timer Timing

Conditions: $V_{CC} = PLLV_{CC} = 3.3\text{ V} \pm 0.3\text{ V}$, $PV_{CC} = 5.0\text{ V} \pm 0.5\text{ V}/3.3\text{ V} \pm 0.3\text{ V}$, $PV_{CC} \geq V_{CC}$,
 $V_{SS} = PV_{SS} = PLLV_{SS} = 0\text{ V}$, $T_a = -20\text{ to }+75^\circ\text{C}$

Item	Symbol	Min	Max	Unit	Figure
WDTOVF delay time	tWOVD	—	70	ns	22.58, 22.59

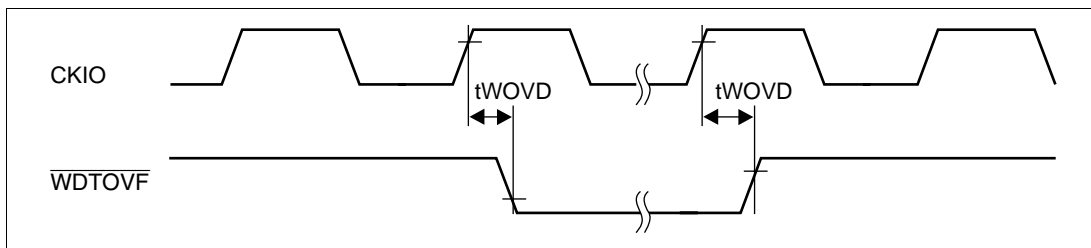

Figure 22.58 Watchdog Timer Output Timing ($t_{Ecy}:t_{Pcyc} = 1:1$)

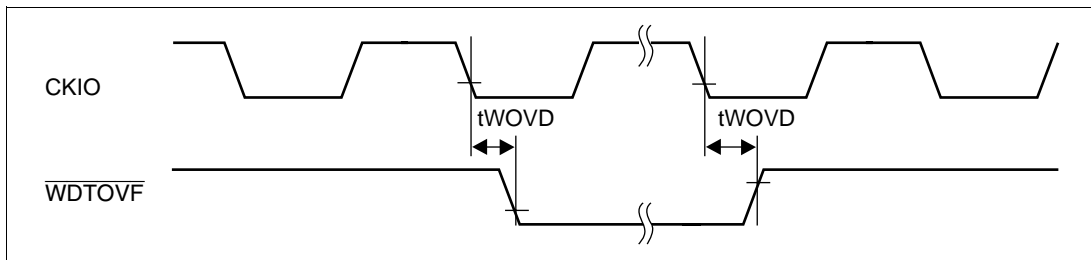

Figure 22.59 Watchdog Timer Output Timing ($t_{Ecy}:t_{Pcyc}$ other than 1:1)

22.3.8 Serial I/O with FIFO / Serial I/O Timing

Table 22.13 Serial I/O with FIFO / Serial I/O Timing

Conditions: $V_{CC} = PLLV_{CC} = 3.3\text{ V} \pm 0.3\text{ V}$, $PV_{CC} = 5.0\text{ V} \pm 0.5\text{ V}/3.3\text{ V} \pm 0.3\text{ V}$, $PV_{CC} \geq V_{CC}$,
 $V_{SS} = PV_{SS} = PLLV_{SS} = 0\text{ V}$, $T_a = -20\text{ to }+75^\circ\text{C}$

Item	Symbol	Min	Max	Unit	Figure
SRCK0, STCK0 clock input cycle time	tSFcyc	—	2	tPcyc	22.60
SRCKn, STCKn clock input cycle time (n = 1 or 2)	tSlcyc	tPcyc or* 66.7	—	ns	
SRCK0, STCK0 clock input low-level width	tSFWL	$0.4 \times \text{tSFcyc}$	—	ns	
SRCKn, STCKn clock input low-level width (n = 1 or 2)	tWL	$0.4 \times \text{tSlcyc}$	—	ns	
SRCK0, STCK0 clock input high-level width	tSFWH	$0.4 \times \text{tSFcyc}$	—	ns	
SRCKn, STCKn clock input high-level width (n = 1 or 2)	tWH	$0.4 \times \text{tSlcyc}$	—	ns	
SRS input setup time	tRSS	15	—	ns	22.61
SRS input hold time	tRSH	10	—	ns	
SRXD input setup time	tSRDS	15	—	ns	
SRXD input hold time	tSRDH	10	—	ns	
STS0 input setup time	tSFTSS	1	—	tPcyc	22.62
STSn input setup time (n = 1 or 2)	tTSS	15	—	ns	
STS input hold time	tTSH	10	—	ns	
STS output delay time	tTSD	0	20	ns	22.63
STXD output delay time	tTDD	0	20	ns	22.62, 22.63

Note: * Specified as tPcyc or 66.7, whichever is greater.

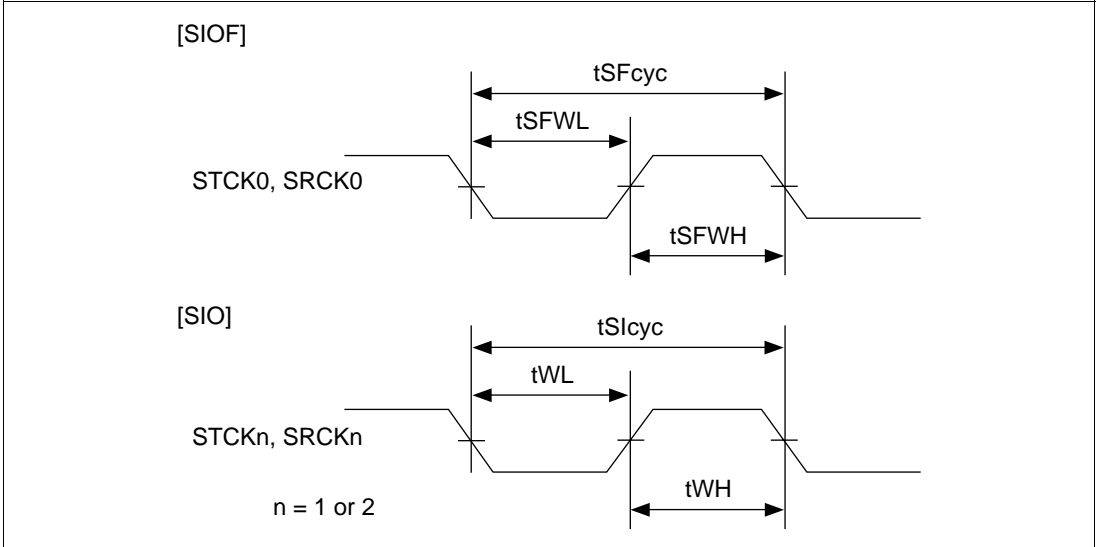

Figure 22.60 SIOF / SIO Input Clock Timing

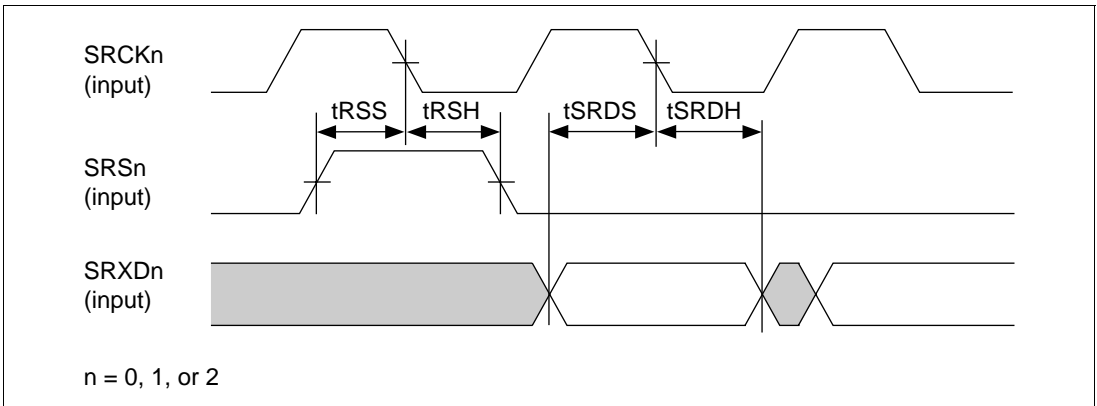

Figure 22.61 SIOF / SIO Receive Timing

[SIOF]

STCK0
(input)

STS0
(input)

STXD0
(output)

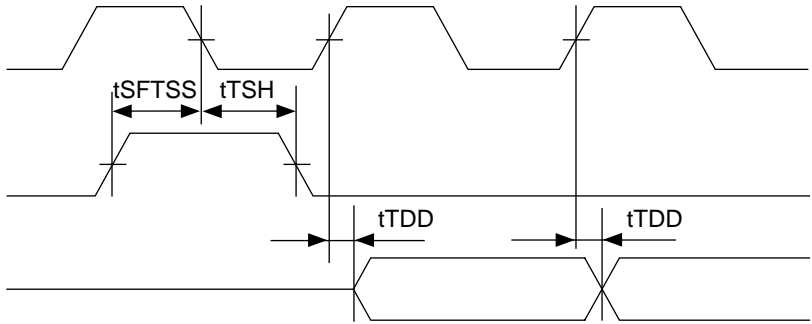

[SIO]

STCKn
(input)

STSn
(input)

STXDn
(output)

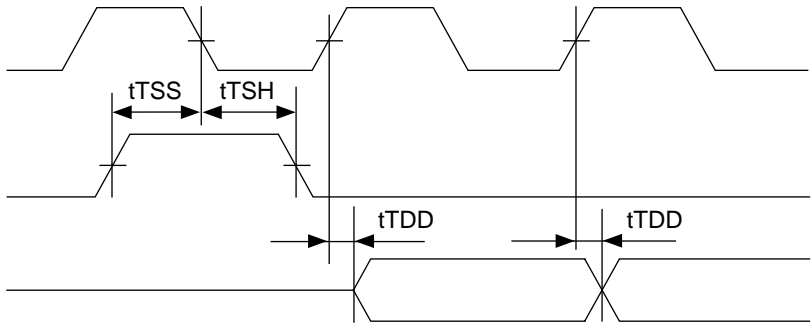

n = 1, or 2

Figure 22.62 SIOF / SIO Transmit Timing (TMn = 0 Mode)

STCKn
(input)

STSn
(output)

STXDn
(output)

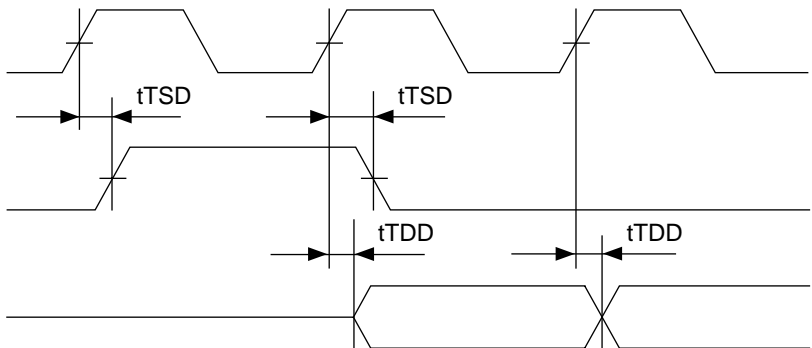

n = 0, 1, or 2

Figure 22.63 SIOF / SIO Transmit Timing (TMn = 1 Mode)

22.3.9 Hitachi User Debug Interface Timing

Table 22.14 Hitachi User Debug Interface Timing

Conditions: $V_{CC} = PLLV_{CC} = 3.3\text{ V} \pm 0.3\text{ V}$, $PV_{CC} = 5.0\text{ V} \pm 0.5\text{ V}/3.3\text{ V} \pm 0.3\text{ V}$, $PV_{CC} \geq V_{CC}$,
 $V_{SS} = PV_{SS} = PLLV_{SS} = 0\text{ V}$, $T_a = -20\text{ to }+75^\circ\text{C}$

Item	Symbol	Min	Max	Unit	Figure
TCK clock input cycle time	ttcyc	tPcyc or* 66.7 ns	—	ns	22.64
TCK clock input high-level width	tTCKH	0.4	0.6	ttcyc	
TCK clock input low-level width	tTCKL	0.4	0.6	ttcyc	
$\overline{\text{TRST}}$ pulse width	tTRSW	20	—	ttcyc	22.65
$\overline{\text{TRST}}$ setup time	tTRSS	40	—	ns	
TMS setup time	tTMSS	30	—	ns	22.66
TMS hold time	tTMSH	10	—	ns	
TDI setup time	tTDIS	30	—	ns	
TDI hold time	tTDIH	10	—	ns	
TDO delay time	tTDOD	0	30	ns	

Note: * Specified as tPcyc or 66.7, whichever is greater.

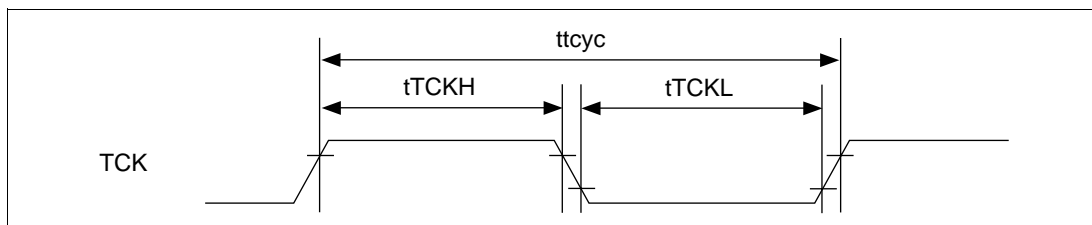

Figure 22.64 H-UDI Clock Timing

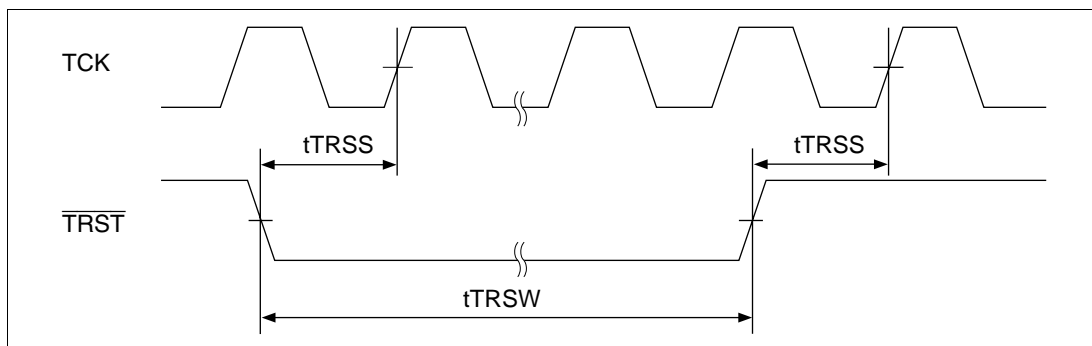

Figure 22.65 H-UDI $\overline{\text{TRST}}$ Timing

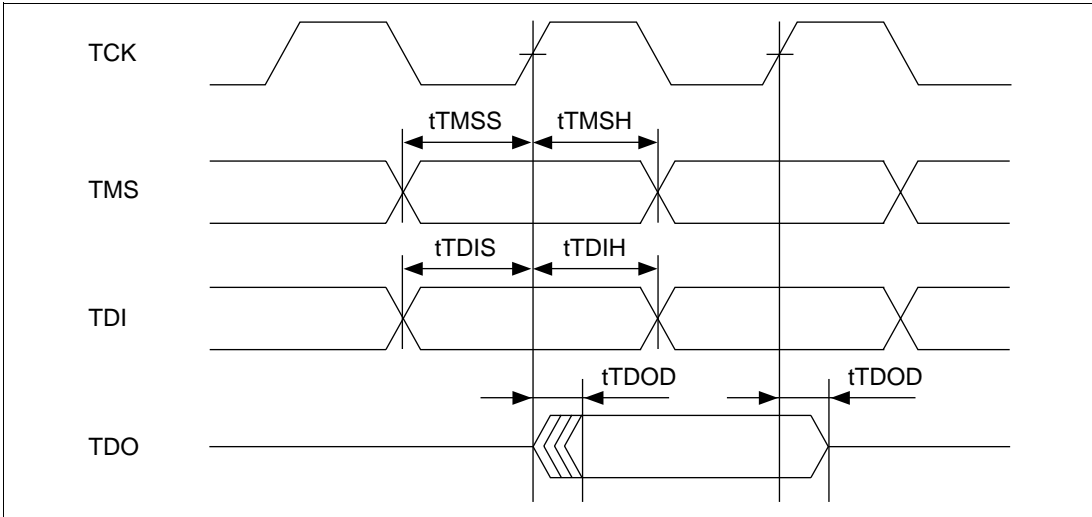

Figure 22.66 H-UDI Input/Output Timing

22.3.10 I/O Port Timing

Table 22.15 I/O Port Timing

Conditions: $V_{CC} = PLLV_{CC} = 3.3\text{ V} \pm 0.3\text{ V}$, $PV_{CC} = 5.0\text{ V} \pm 0.5\text{ V}/3.3\text{ V} \pm 0.3\text{ V}$, $PV_{CC} \geq V_{CC}$,
 $V_{SS} = PV_{SS} = PLLV_{SS} = 0\text{ V}$, $T_a = -20\text{ to }+75^\circ\text{C}$

Item	Symbol	Min	Max	Unit	Figure
Port output data delay time	tPWD	—	50	ns	22.67, 22.68
Port input data setup time (tE _{cyc} :tP _{cyc} = 1:1)	tPRS	50	—	ns	22.67
Port input data setup time (tE _{cyc} :tP _{cyc} = 1:2)	tPRS	t _{cyc} + 50	—	ns	22.68
Port input data setup time (tE _{cyc} :tP _{cyc} = 1:4)	tPRS	3t _{cyc} + 50	—	ns	
Port input data hold time	tPRH	50	—	ns	22.67, 22.68

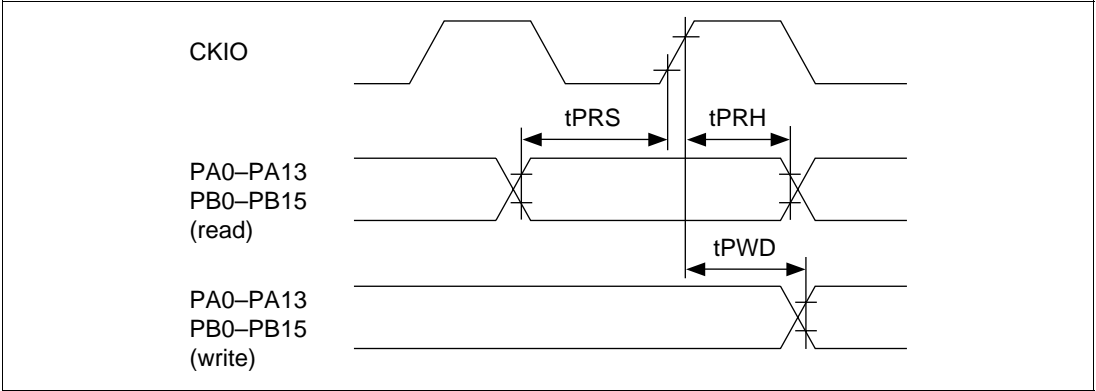

Figure 22.67 I/O Port Input/Output Timing ($t_{EcyC}:t_{PcyC} = 1:1$)

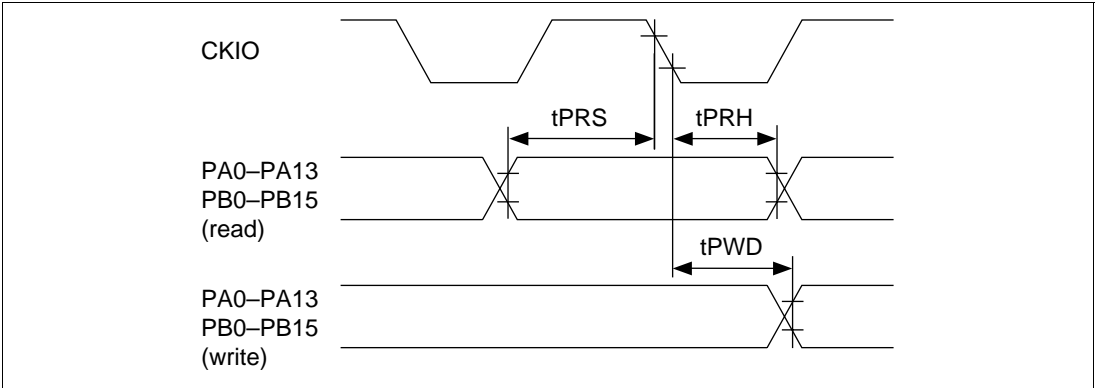

Figure 22.68 I/O Port Input/Output Timing ($t_{EcyC}:t_{PcyC} \neq 1:1$)

22.3.11 Ethernet Controller Timing

Table 22.16 Ethernet Controller Timing

Conditions: $V_{CC} = PLLV_{CC} = 3.3\text{ V} \pm 0.3\text{ V}$, $PV_{CC} = 5.0\text{ V} \pm 0.5\text{ V}/3.3\text{ V} \pm 0.3\text{ V}$, $PV_{CC} \geq V_{CC}$,
 $V_{SS} = PV_{SS} = PLLV_{SS} = 0\text{ V}$, $T_a = -20\text{ to }+75^\circ\text{C}$

Item	Symbol	Min	Typ	Max	Unit	Figure
TX-CLK cycle time	tTcyc	2.4	—	—	tcyc	22.69
TX-EN output delay time	tTENd	3	—	20	ns	
ETXD[3:0] output delay time	tETDd	3	—	20	ns	
CRS setup time	tCRSs	10	—	—	ns	
CRS hold time	tCRSh	10	—	—	ns	
COL setup time	tCOLs	10	—	—	ns	22.70
COL hold time	tCOLh	10	—	—	ns	
RX-CLK cycle time	tRcyc	2.4	—	—	tcyc	22.71
RX-DV setup time	tRDVs	10	—	—	ns	
RX-DV hold time	tRDVh	3	—	—	ns	
ERXD[3:0] setup time	tERDs	10	—	—	ns	
ERXD[3:0] hold time	tERDh	3	—	—	ns	
RX-ER setup time	tRERs	10	—	—	ns	22.72
RX-ER hold time	tRERh	3	—	—	ns	
MDIO setup time	tMDIOs	10	—	—	ns	22.73
MDIO hold time	tMDIOh	10	—	—	ns	
MDIO output data hold time*	tMDIOdh	5	—	18	ns	22.74
WOL output delay time	tWOLd	1	—	18	ns	22.75
EXOUT output delay time	tEXOUTd	1	—	28	ns	22.76
CAMSEN setup time	tCAMs	10	—	—	ns	22.77
CAMSEN hold time	tCAMh	3	—	—	ns	

Note: * The user must ensure that the code satisfies this condition.

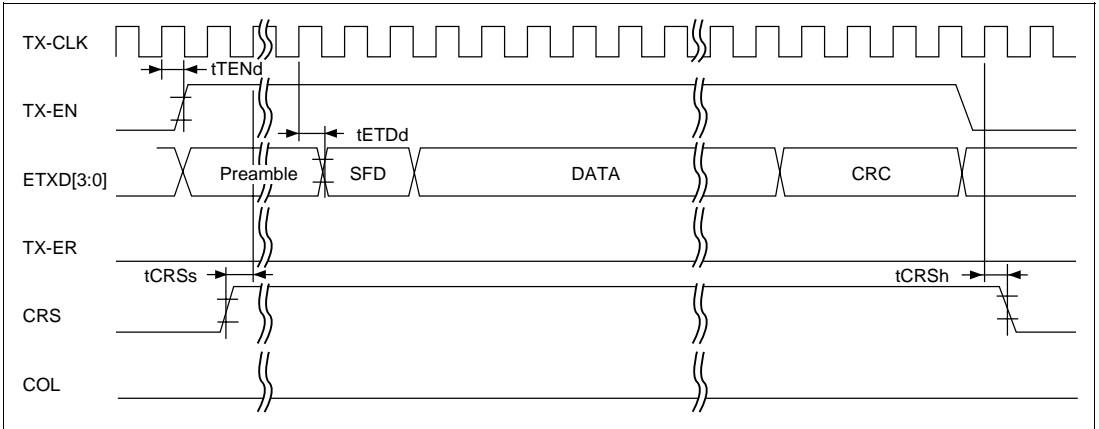

Figure 22.69 MII Send Timing (Normal Operation)

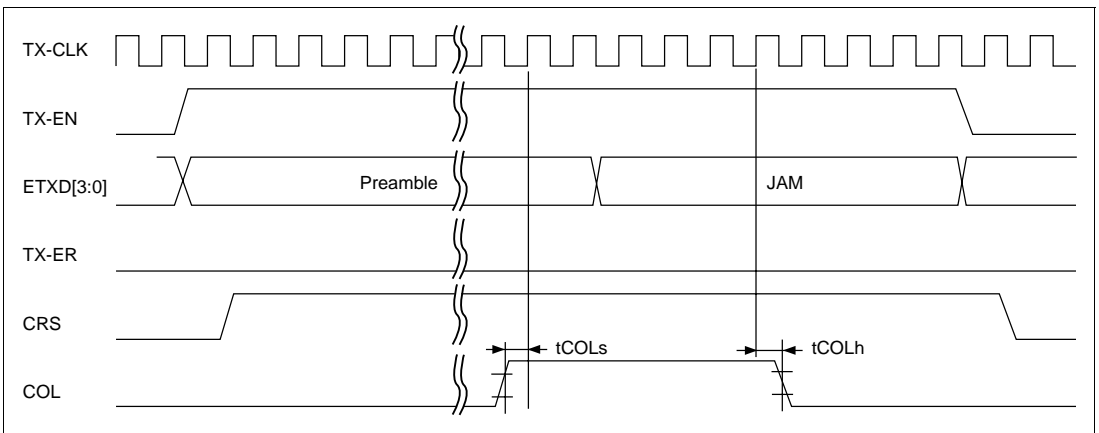

Figure 22.70 MII Send Timing (Case of Conflict)

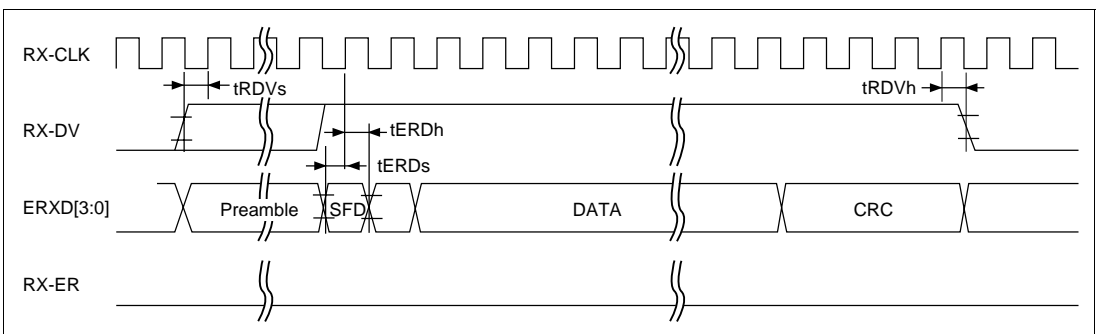

Figure 22.71 MII Receive Timing (Normal Operation)

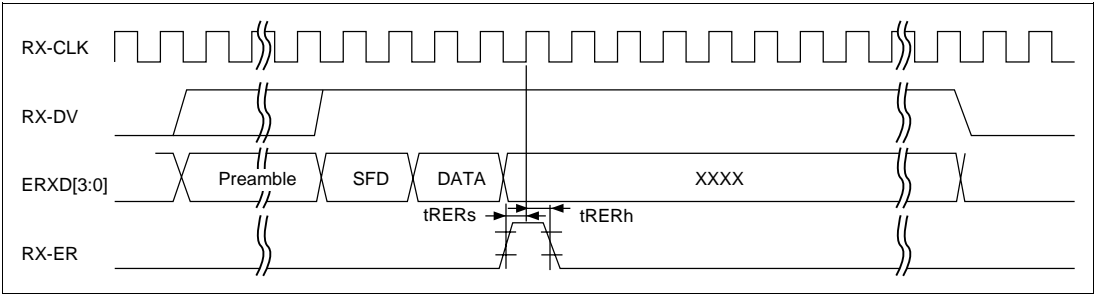

Figure 22.72 MII Receive Timing (Case of Error)

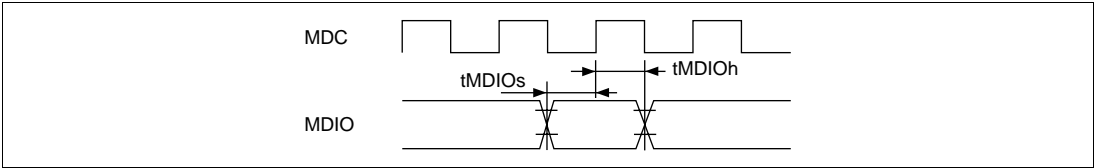

Figure 22.73 MDIO Input Timing

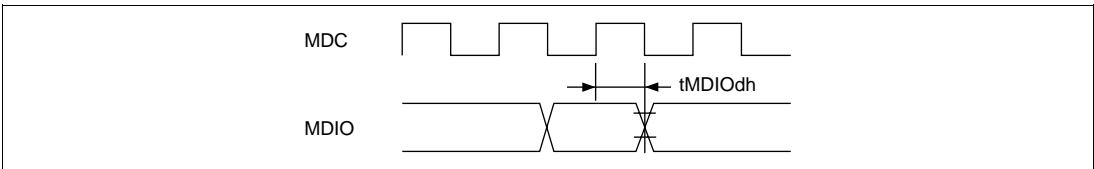

Figure 22.74 MDIO Output Timing

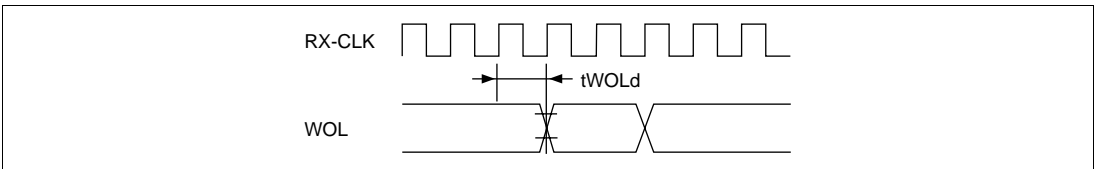

Figure 22.75 WOL Output Timing

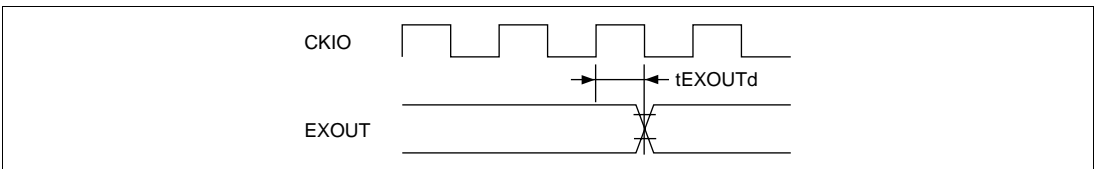

Figure 22.76 EXOUT Output Timing

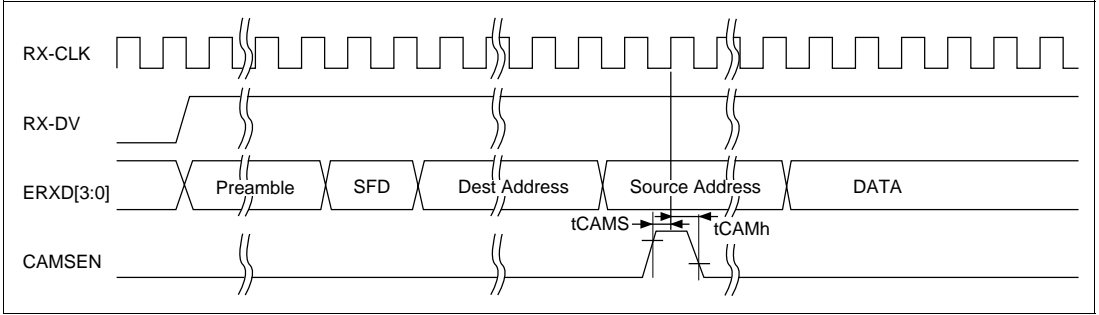

Figure 22.77 CAMSEN Input Timing

22.3.12 STATS, $\overline{\text{BH}}$, and $\overline{\text{BUSHiZ}}$ Signal Timing

Table 22.17 STATS, $\overline{\text{BH}}$, and $\overline{\text{BUSHiZ}}$ Signal Timing

Conditions: $V_{CC} = \text{PLL}V_{CC} = 3.3 \text{ V} \pm 0.3 \text{ V}$, $PV_{CC} = 5.0 \text{ V} \pm 0.5 \text{ V}/3.3 \text{ V} \pm 0.3 \text{ V}$, $PV_{CC} \geq V_{CC}$,
 $V_{SS} = PV_{SS} = \text{PLL}V_{SS} = 0 \text{ V}$, $T_a = -20$ to $+75^\circ\text{C}$

Item	Symbol	Min	Typ	Max	Unit	Figure
STAS1 and STAS0 output delay time	tSTATd	—	—	16	ns	22.77
$\overline{\text{BH}}$ output rising edge delay time	tBHNrd	—	—	16	ns	22.78
$\overline{\text{BH}}$ output falling edge delay time	tBHNfd	—	—	16	ns	
$\overline{\text{BUSHiZ}}$ setup time	tBHIZs	7	—	—	ns	22.79
$\overline{\text{BUSHiZ}}$ hold time	tBHIZh	8	—	—	ns	
Output delay time of target pins	tBHIZd	—	—	16	ns	

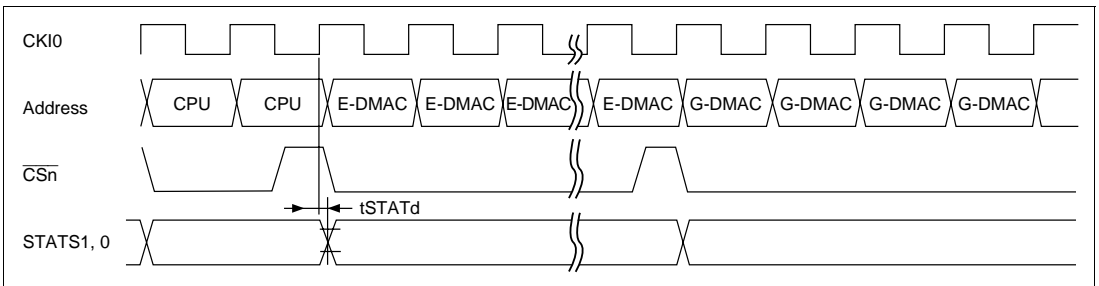

Figure 22.78 STATS Output Timing

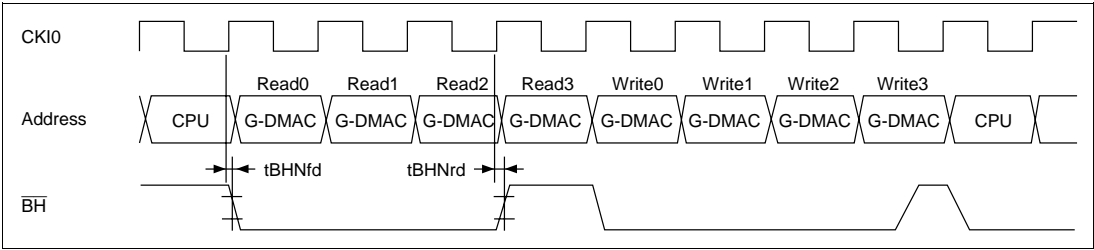

Figure 22.79 \overline{BH} Output Timing

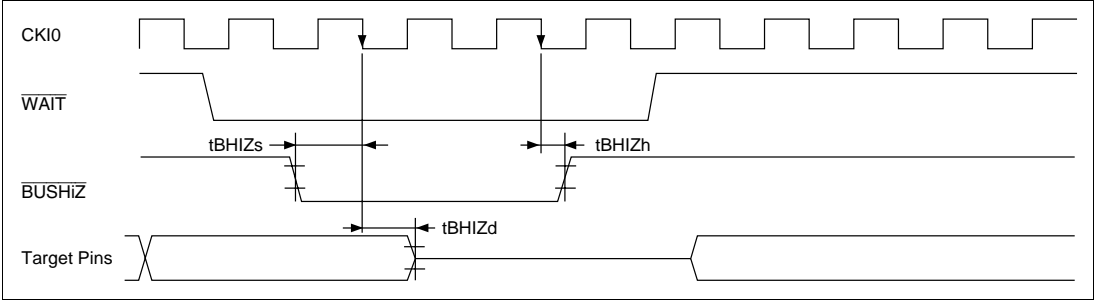

Figure 22.80 \overline{BUSHiZ} Bus Timing

22.4 AC Characteristic Test Conditions

The AC characteristic test conditions are as follows:

- Input/output signal reference level: 1.5 V ($V_{CC} = 3.3$ to 3.6 V)
- Input pulse level: V_{SS} to 3.0 V (V_{SS} to V_{CC} for \overline{RES} , \overline{TRST} , \overline{EXTAL} , CKIO, MD0–MD4, and NMI)
- Input rise/fall time: 1 ns

The output load circuit is shown in figure 22.81.

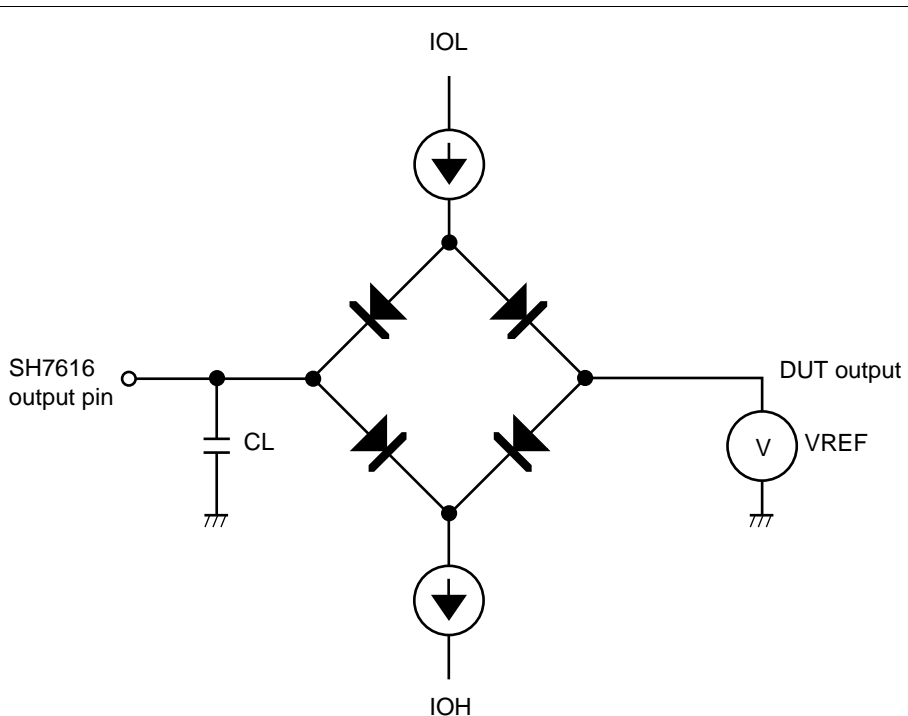

CL is the total value, including the capacitance of the test jig, etc. The capacitance of each pin is as follows:

30 pF: CKIO, A24–A0, D31–D0, \overline{BS} , \overline{RD} , $\overline{CS4}$ – $\overline{CS0}$, $\overline{DQMUU/WE3}$ – $\overline{DQMLL/WE0}$, $\overline{CAS3}$ – $\overline{CAS0}$, \overline{RAS} , $\overline{CAS/OE}$, DACK1, DACK0

50 pF: All other pins

IOL and IOH values are as shown in table 22.3, Permissible Output Currents.

Figure 22.81 Output Load Circuit

Appendix A On-Chip Peripheral Module Registers

A.1 Addresses

On-chip peripheral module register addresses and bit names are shown in the following table. 16-bit registers and 32-bit registers are shown, respectively, in two and four lines of 8 bits.

Address	Register Name	Bit Names								Module
		Bit 7	Bit 6	Bit 5	Bit 4	Bit 3	Bit 2	Bit 1	Bit 0	
H'FFFFFFC00	SIRDR									SIOF
H'FFFFFFC01										
H'FFFFFFC02	SITDR									
H'FFFFFFC03										
H'FFFFFFC04	SICTR	—	—	—	—	—	DMACE	TCIE	RCIE	
H'FFFFFFC05		—	TM	SE	DL	TIE	RIE	TE	RE	
H'FFFFFFC06	SISTR	—	—	—	—	—	—	TCD	RCD	
H'FFFFFFC07		—	—	—	—	TERR	RERR	TDRE	RDRF	
H'FFFFFFC08	SIFCR	—	—	—	—	TRMD	LM	RFRST	TFRST	
H'FFFFFFC09		RFWM3	RFWM2	RFWM1	RFWM0	TFWM3	TFWM2	TFWM1	TFWM0	
H'FFFFFFC0A	SIFDR	—	—	—	R4	R3	R2	R1	R0	
H'FFFFFFC0B		—	—	—	T4	T3	T2	T1	T0	
H'FFFFFFC0C	SIRCDR									
H'FFFFFFC0D										
H'FFFFFFC0E	SITCDR									
H'FFFFFFC0F										
H'FFFFFFC10	SIRDR1									SIO
H'FFFFFFC11										
H'FFFFFFC12	SITDR1									
H'FFFFFFC13										
H'FFFFFFC14	SICTR1	—	—	—	—	—	—	—	—	
H'FFFFFFC15		—	TM	SE	DL	TIE	RIE	TE	RE	
H'FFFFFFC16	SISTR1	—	—	—	—	—	—	—	—	
H'FFFFFFC17		—	—	—	—	TERR	RERR	TDRE	RDRF	
H'FFFFFFC18 to H'FFFFFFC1F	—	—	—	—	—	—	—	—	—	—

Address	Register Name	Bit Names								Module
		Bit 7	Bit 6	Bit 5	Bit 4	Bit 3	Bit 2	Bit 1	Bit 0	
H'FFFFFFC20	SIRDR2									SIO
H'FFFFFFC21										
H'FFFFFFC22	SITDR2									
H'FFFFFFC23										
H'FFFFFFC24	SICTR2	—	—	—	—	—	—	—	—	
H'FFFFFFC25		—	TM	SE	DE	TIE	RIE	TE	RE	
H'FFFFFFC26	SISTR2	—	—	—	—	—	—	—	—	
H'FFFFFFC27		—	—	—	—	TERR	RERR	TDRE	RDRF	
H'FFFFFFC28 to H'FFFFFFC3F	—	—	—	—	—	—	—	—	—	—
H'FFFFFFC40	TSTR	—	—	—	—	—	CST2	CST1	CST0	TPU
H'FFFFFFC41	TSYR	—	—	—	—	—	SYNC2	SYNC1	SYNC0	
H'FFFFFFC42 to H'FFFFFFC4F	—	—	—	—	—	—	—	—	—	—
H'FFFFFFC50	TCR0	CCLR2	CCLR1	CCLR0	CKEG1	CKEG0	TPSC2	TPSC1	TPSC0	TPU
H'FFFFFFC51	TMDR0	—	—	BFB	BFA	MD3	MD2	MD1	MD0	
H'FFFFFFC52	TIOR0H	IOB3	IOB2	IOB1	IOB0	IOA3	IOA2	IOA1	IOA0	
H'FFFFFFC53	TIOR0L	IOD3	IOD2	IOD1	IOD0	IOC3	IOC2	IOC1	IOC0	
H'FFFFFFC54	TIER0	—	—	—	TCIEV	TGIED	TGIEC	TGIEB	TGIEA	
H'FFFFFFC55	TSR0	—	—	—	TCFV	TGFD	TGFC	TGFB	TGFA	
H'FFFFFFC56	TCNT0									
H'FFFFFFC57										
H'FFFFFFC58	TGR0A									
H'FFFFFFC59										
H'FFFFFFC5A	TGR0B									
H'FFFFFFC5B										
H'FFFFFFC5C	TGR0C									
H'FFFFFFC5D										
H'FFFFFFC5E	TGR0D									
H'FFFFFFC5F										
H'FFFFFFC60	TCR1	—	CCLR1	CCLR0	CKEG1	CKEG0	TPSC2	TPSC1	TPSC0	
H'FFFFFFC61	TMDR1	—	—	—	—	MD3	MD2	MD1	MD0	
H'FFFFFFC62	TIOR1	IOB3	IOB2	IOB1	IOB0	IOA3	IOA2	IOA1	IOA0	
H'FFFFFFC63	—	—	—	—	—	—	—	—	—	
H'FFFFFFC64	TIER1	—	—	TCIEU	TCIEV	—	—	TGIEB	TGIEA	
H'FFFFFFC65	TSR1	TCFD	—	TCFU	TCFV	—	—	TGFB	TGFA	

Address	Register Name	Bit Names								Module
		Bit 7	Bit 6	Bit 5	Bit 4	Bit 3	Bit 2	Bit 1	Bit 0	
H'FFFFFFC66	TCNT1									TPU
H'FFFFFFC67										
H'FFFFFFC68	TGR1A									
H'FFFFFFC69										
H'FFFFFFC6A	TGR1B									
H'FFFFFFC6B										
H'FFFFFFC6C to H'FFFFFFC6F	—	—	—	—	—	—	—	—	—	—
H'FFFFFFC70	TCR2	—	CCLR1	CCLR0	CKEG1	CKEG0	TPSC2	TPSC1	TPSC0	TPU
H'FFFFFFC71	TMDR2	—	—	—	—	MD3	MD2	MD1	MD0	
H'FFFFFFC72	TIOR2	IOB3	IOB2	IOB1	IOB0	IOA3	IOA2	IOA1	IOA0	
H'FFFFFFC73	—	—	—	—	—	—	—	—	—	
H'FFFFFFC74	TIER2	—	—	TCIEU	TCIEV	—	—	TGIEB	TGIEA	
H'FFFFFFC75	TSR2	TCFD	—	TCFU	TCFV	—	—	TGFB	TGFA	
H'FFFFFFC76	TCNT2									
H'FFFFFFC77										
H'FFFFFFC78	TGR2A									
H'FFFFFFC79										
H'FFFFFFC7A	TGR2B									
H'FFFFFFC7B										
H'FFFFFFC7C to H'FFFFFFC7F	—	—	—	—	—	—	—	—	—	—
H'FFFFFFC80	PACR	—	—	PA13MD	PA12MD	PA11MD	PA10MD	PA9MD	PA8MD	PFC
H'FFFFFFC81		PA7MD	PA6MD	PA5MD	PA4MD	PA3MD	PA2MD	PA1MD	PA0MD	
H'FFFFFFC82	PAIOR	—	—	PA13IOR	PA12IOR	PA11IOR	PA10IOR	PA9IOR	PA8IOR	
H'FFFFFFC83		PA7IOR	PA6IOR	PA5IOR	PA4IOR	—	PA2IOR	PA1IOR	PA0IOR	
H'FFFFFFC84	PADR	—	—	PA13DR	PA12DR	PA11DR	PA10DR	PA9DR	PA8DR	I/O port
H'FFFFFFC85		PA7DR	PA6DR	PA5DR	PA4DR	—	PA2DR	PA1DR	PA0DR	
H'FFFFFFC86 to H'FFFFFFC87	—	—	—	—	—	—	—	—	—	—
H'FFFFFFC88	PBCR	PB15MD1	PB15MD0	PB14MD1	PB14MD0	PB13MD1	PB13MD0	PB12MD1	PB12MD0	PFC
H'FFFFFFC89		PB11MD1	PB11MD0	PB10MD1	PB10MD0	PB9MD1	PB9MD0	PB8MD1	PB8MD0	
H'FFFFFFC8A	PBIOR	PB15IOR	PB14IOR	PB13IOR	PB12IOR	PB11IOR	PB10IOR	PB9IOR	PB8IOR	
H'FFFFFFC8B		PB7IOR	PB6IOR	PB5IOR	PB4IOR	PB3IOR	PB2IOR	PB1IOR	PB0IOR	
H'FFFFFFC8C	PBDR	PB15DR	PB14DR	PB13DR	PB12DR	PB11DR	PB10DR	PB9DR	PB8DR	I/O port
H'FFFFFFC8D		PB7DR	PB6DR	PB5DR	PB4DR	PB3DR	PB2DR	PB1DR	PB0DR	

Address	Register Name	Bit Names								Module
		Bit 7	Bit 6	Bit 5	Bit 4	Bit 3	Bit 2	Bit 1	Bit 0	
H'FFFFFFC8E	PBCR2	PB7MD1	PB7MD0	PB6MD1	PB6MD0	PB5MD1	PB5MD0	PB4MD1	PB4MD0	PFC
H'FFFFFFC8F		PB3MD1	PB3MD0	PB2MD1	PB2MD0	PB1MD1	PB1MD0	PB0MD1	PB0MD0	
H'FFFFFFC90 to H'FFFFFFCAF	—	—	—	—	—	—	—	—	—	—
H'FFFFFF CB0	SDIR	TS3	TS2	TS1	TS0	—	—	—	—	H-UDI
H'FFFFFF CB1		—	—	—	—	—	—	—	—	
H'FFFFFF CB2	SDSR	—	—	—	—	—	—	—	—	
H'FFFFFF CB3		—	—	—	—	—	—	—	SDTRF	
H'FFFFFF CB4	SDDRH									H-UDI
H'FFFFFF CB5										
H'FFFFFF CB6	SDDRL									
H'FFFFFF CB7										
H'FFFFFF CB8 to H'FFFFFF CBF	—	—	—	—	—	—	—	—	—	—
H'FFFF FCC0	SCBRR1	C/ \bar{A}	CHR/ICK3	PE/ICK1	O/ \bar{E} /ICK1	STOP/ ICK0	MP	CKS1	CKS0	SCIF1
H'FFFF FCC1	—	—	—	—	—	—	—	—	—	
H'FFFF FCC2	SCBRR1									
H'FFFF FCC3	—	—	—	—	—	—	—	—	—	
H'FFFF FCC4	SCSCR1	TIE	RIE	TE	RE	MPIE	—	CKE1	CKE0	
H'FFFF FCC5	—	—	—	—	—	—	—	—	—	
H'FFFF FCC6	SCFTDR1									
H'FFFF FCC7	—	—	—	—	—	—	—	—	—	
H'FFFF FCC8	SC1SSR1	PER3	PER2	PER1	PER0	FER3	FER2	FER1	FER0	
H'FFFF FCC9		ER	TEND	TDFE	BRK	FER	PER	RDF	DR	
H'FFFF FCCA	SC2SSR1	TLM	RLM	N1	N0	MPB	MPBT	EI	ORER	
H'FFFF FCCB	—	—	—	—	—	—	—	—	—	
H'FFFF FCCC	SCFRDR1									
H'FFFF FCCD	—	—	—	—	—	—	—	—	—	
H'FFFF FCCE	SCFCR1	RTRG1	RTRG0	TTRG1	TTRG0	MCE	TFRST	RFRST	LOOP	
H'FFFF FCCF	—	—	—	—	—	—	—	—	—	
H'FFFF FCD0	SCFDR1	—	—	—	T4	T3	T2	T1	T0	SCIF1
H'FFFF FCD1		—	—	—	R4	R3	R2	R1	R0	
H'FFFF FCD2	SCFER1	ED15	ED14	ED13	ED12	ED11	ED10	ED9	ED8	
H'FFFF FCD3		ED7	ED6	ED5	ED4	ED3	ED2	ED1	ED0	
H'FFFF FCD4	SCIMR1	IRMOD	PSEL	RIVS	—	—	—	—	—	

Address	Register Name	Bit Names								Module
		Bit 7	Bit 6	Bit 5	Bit 4	Bit 3	Bit 2	Bit 1	Bit 0	
H'FFFF FCD5 to H'FFFF FCDF	—	—	—	—	—	—	—	—	—	—
H'FFFF FCE0	SCSMR2	C/ \bar{A}	CHR/ICK3	PE/ICK2	O/ \bar{E} /ICK1	STOP/ ICK0	MP	CKS1	CKS0	SCIF2
H'FFFF FCE1	—	—	—	—	—	—	—	—	—	—
H'FFFF FCE2	SCBRR2	—	—	—	—	—	—	—	—	—
H'FFFF FCE3	—	—	—	—	—	—	—	—	—	—
H'FFFF FCE4	SCSCR2	TIE	RIE	TE	RE	MPIE	—	CKE1	CKE0	—
H'FFFF FCE5	—	—	—	—	—	—	—	—	—	—
H'FFFF FCE6	SCFTDR2	—	—	—	—	—	—	—	—	—
H'FFFF FCE7	—	—	—	—	—	—	—	—	—	—
H'FFFF FCE8	SC1SSR2	PER3	PER2	PER1	PER0	FER3	FER2	FER1	FER0	—
H'FFFF FCE9	—	ER	TEND	TDFE	BRK	FER	PER	RDF	DR	—
H'FFFF FCEA	SC2SSR2	TLM	RLM	N1	N0	MPB	MPBT	EI	ORER	—
H'FFFF FCEB	—	—	—	—	—	—	—	—	—	—
H'FFFF FCEC	SCFRDR2	—	—	—	—	—	—	—	—	—
H'FFFF FCEE	SCFCR2	RTRG1	RTRG0	TTRG1	TTRG0	MCE	TFRST	RFRST	LOOP	—
H'FFFF FCEF	—	—	—	—	—	—	—	—	—	—
H'FFFF FCF0	SCFDR2	—	—	—	T4	T3	T2	T1	T0	—
H'FFFF FCF1	—	—	—	—	R4	R3	R2	R1	R0	—
H'FFFF FCF2	SCFER2	ED15	ED14	ED13	ED12	ED11	ED10	ED9	ED8	—
H'FFFF FCF3	—	ED7	ED6	ED5	ED4	ED3	ED2	ED1	ED0	—
H'FFFF FCF4	SCIMR2	IRMOD	PSEL	RIVS	—	—	—	—	—	—
H'FFFF FCF5 to H'FFFF FCFF	—	—	—	—	—	—	—	—	—	—
H'FFFF FD00	EDMR	—	—	—	—	—	—	—	—	E-DMAC
H'FFFF FD01	—	—	—	—	—	—	—	—	—	—
H'FFFF FD02	—	—	—	—	—	—	—	—	—	—
H'FFFF FD03	—	—	—	DL1	DL0	—	—	—	SWR	—
H'FFFF FD04	EDTRR	—	—	—	—	—	—	—	—	—
H'FFFF FD05	—	—	—	—	—	—	—	—	—	—
H'FFFF FD06	—	—	—	—	—	—	—	—	—	—
H'FFFF FD07	—	—	—	—	—	—	—	—	TR	—

Address	Register Name	Bit Names								Module
		Bit 7	Bit 6	Bit 5	Bit 4	Bit 3	Bit 2	Bit 1	Bit 0	
H'FFFF FD08	EDRRR	—	—	—	—	—	—	—	—	E-DMAC
H'FFFF FD09		—	—	—	—	—	—	—	—	
H'FFFF FD0A		—	—	—	—	—	—	—	—	
H'FFFF FD0B		—	—	—	—	—	—	—	RR	
H'FFFF FD0C	TDLAR	TDLA31	TDLA30	TDLA29	TDLA28	TDLA27	TDLA26	TDLA25	TDLA24	
H'FFFF FD0D		TDLA23	TDLA22	TDLA21	TDLA20	TDLA19	TDLA18	TDLA17	TDLA16	
H'FFFF FD0E		TDLA15	TDLA14	TDLA13	TDLA12	TDLA11	TDLA10	TDLA9	TDLA8	
H'FFFF FD0F		TDLA7	TDLA6	TDLA5	TDLA4	TDLA3	TDLA2	TDLA1	TDLA0	
H'FFFF FD10	RDLAR	RDLA31	RDLA30	RDLA29	RDLA28	RDLA27	RDLA26	RDLA25	RDLA24	
H'FFFF FD11		RDLA23	RDLA22	RDLA21	RDLA20	RDLA19	RDLA18	RDLA17	RDLA16	
H'FFFF FD12		RDLA15	RDLA14	RDLA13	RDLA12	RDLA11	RDLA10	RDLA9	RDLA8	
H'FFFF FD13		RDLA7	RDLA6	RDLA5	RDLA4	RDLA3	RDLA2	RDLA1	RDLA0	
H'FFFF FD14	EESR	—	—	—	—	—	—	—	RFCOF	
H'FFFF FD15		—	ECI	TC	TDE	TFUF	FR	RDE	RFOF	
H'FFFF FD16		—	—	—	ITF	CND	DLC	CD	TRO	
H'FFFF FD17		RMAF	—	RFAR	RRF	RTLf	RTSF	PRE	CERF	
H'FFFF FD18	EESIPR	—	—	—	—	—	—	—	RFCOFIP	
H'FFFF FD19		—	ECIIP	TCIP	TDEIP	TFUFIP	FRIP	RDEIP	RFOFIP	
H'FFFF FD1A		—	—	—	ITFIP	CNDIP	DLCIP	CDIP	TROIP	
H'FFFF FD1B		RMAFIP	—	RFARIP	RRFIP	RTLFIp	RTSFIP	PREIP	CERFIP	
H'FFFF FD1C	TRSCER	—	—	—	—	—	—	—	—	
H'FFFF FD1D		—	—	—	—	—	—	—	—	
H'FFFF FD1E		—	—	—	ITFCE	CNDCE	DLCCE	CDCE	TROCE	
H'FFFF FD1F		RMAFCE	—	RFARCE	RRFCE	RTLFCe	RTSFCE	PRECE	CERFCE	
H'FFFF FD20	RMFCR	—	—	—	—	—	—	—	—	
H'FFFF FD21		—	—	—	—	—	—	—	—	
H'FFFF FD22		MFC15	MFC14	MFC13	MFC12	MFC11	MFC10	MFC9	MFC8	
H'FFFF FD23		MFC7	MFC6	MFC5	MFC4	MFC3	MFC2	MFC1	MFC0	
H'FFFF FD24	TFTR	—	—	—	—	—	—	—	—	
H'FFFF FD25		—	—	—	—	—	—	—	—	
H'FFFF FD26		—	—	—	—	—	TFT10	TFT9	TFT8	
H'FFFF FD27		TFT7	TFT6	TFT5	TFT4	TFT3	TFT2	TFT1	TFT0	

Address	Register Name	Bit Names								Module
		Bit 7	Bit 6	Bit 5	Bit 4	Bit 3	Bit 2	Bit 1	Bit 0	
H'FFFF FD28	FDR	—	—	—	—	—	—	—	—	E-DMAC
H'FFFF FD29		—	—	—	—	—	—	—	—	
H'FFFF FD2A		—	—	—	—	—	TFD2	TFD1	TFD0	
H'FFFF FD2B		—	—	—	—	—	RFD2	RFD1	RFD0	
H'FFFF FD2C	RCR	—	—	—	—	—	—	—	—	
H'FFFF FD2D		—	—	—	—	—	—	—	—	
H'FFFF FD2E		—	—	—	—	—	—	—	—	
H'FFFF FD2F		—	—	—	—	—	—	—	RNC	
H'FFFF FD30	EDOCR	—	—	—	—	—	—	—	—	
H'FFFF FD31		—	—	—	—	—	—	—	—	
H'FFFF FD32		—	—	—	—	—	—	—	—	
H'FFFF FD33		—	—	—	—	FEC	AEC	EDH	—	
H'FFFF FD34 to H'FFFF FD3F	—	—	—	—	—	—	—	—	—	
H'FFFF FD40	RBWAR	RBWA31	RBWA30	RBWA29	RBWA28	RBWA27	RBWA26	RBWA25	RBWA24	
H'FFFF FD41		RBWA23	RBWA22	RBWA21	RBWA20	RBWA19	RBWA18	RBWA17	RBWA16	
H'FFFF FD42		RBWA15	RBWA14	RBWA13	RBWA12	RBWA11	RBWA10	RBWA9	RBWA8	
H'FFFF FD43		RBWA7	RBWA6	RBWA5	RBWA4	RBWA3	RBWA2	RBWA1	RBWA0	
H'FFFF FD44	RDFAR	RDFA31	RDFA30	RDFA29	RDFA28	RDFA27	RDFA26	RDFA25	RDFA24	
H'FFFF FD45		RDFA23	RDFA22	RDFA21	RDFA20	RDFA19	RDFA18	RDFA17	RDFA16	
H'FFFF FD46		RDFA15	RDFA14	RDFA13	RDFA12	RDFA11	RDFA10	RDFA9	RDFA8	
H'FFFF FD47		RDFA7	RDFA6	RDFA5	RDFA4	RDFA3	RDFA2	RDFA1	RDFA0	
H'FFFF FD48 to H'FFFF FD4B	—	—	—	—	—	—	—	—	—	
H'FFFF FD4C	TBRAR	TBRA31	TBRA30	TBRA29	TBRA28	TBRA27	TBRA26	TBRA25	TBRA24	
H'FFFF FD4D		TBRA23	TBRA22	TBRA21	TBRA20	TBRA19	TBRA18	TBRA17	TBRA16	
H'FFFF FD4E		TBRA15	TBRA14	TBRA13	TBRA12	TBRA11	TBRA10	TBRA9	TBRA8	
H'FFFF FD4F		TBRA7	TBRA6	TBRA5	TBRA4	TBRA3	TBRA2	TBRA1	TBRA0	
H'FFFF FD50	TDFAR	TDFA31	TDFA30	TDFA29	TDFA28	TDFA27	TDFA26	TDFA25	TDFA24	
H'FFFF FD51		TDFA23	TDFA22	TDFA21	TDFA20	TDFA19	TDFA18	TDFA17	TDFA16	
H'FFFF FD52		TDFA15	TDFA14	TDFA13	TDFA12	TDFA11	TDFA10	TDFA9	TDFA8	
H'FFFF FD53		TDFA7	TDFA6	TDFA5	TDFA4	TDFA3	TDFA2	TDFA1	TDFA0	
H'FFFF FD54 to H'FFFF FD5F	—	—	—	—	—	—	—	—	—	

Address	Register Name	Bit Names								Module
		Bit 7	Bit 6	Bit 5	Bit 4	Bit 3	Bit 2	Bit 1	Bit 0	
H'FFFF FD60	ECMR	—	—	—	—	—	—	—	—	EtherC
H'FFFF FD61		—	—	—	—	—	—	—	—	
H'FFFF FD62		—	—	—	PRCEF	—	—	MPDE	—	
H'FFFF FD63		—	RE	TE	—	ILB	ELB	DM	PRM	
H'FFFF FD64	ECSR	—	—	—	—	—	—	—	—	
H'FFFF FD65		—	—	—	—	—	—	—	—	
H'FFFF FD66		—	—	—	—	—	—	—	—	
H'FFFF FD67		—	—	—	—	—	LCHNG	MPD	ICD	
H'FFFF FD68	ECSIPR	—	—	—	—	—	—	—	—	
H'FFFF FD69		—	—	—	—	—	—	—	—	
H'FFFF FD6A		—	—	—	—	—	—	—	—	
H'FFFF FD6B		—	—	—	—	—	LCHNGIP	MPDIP	ICDIP	
H'FFFF FD6C	PIR	—	—	—	—	—	—	—	—	
H'FFFF FD6D		—	—	—	—	—	—	—	—	
H'FFFF FD6E		—	—	—	—	—	—	—	—	
H'FFFF FD6F		—	—	—	—	MDI	MDO	MMD	MMC	
H'FFFF FD70	MAHR	MA47	MA46	MA45	MA44	MA43	MA42	MA41	MA40	
H'FFFF FD71		MA39	MA38	MA37	MA36	MA35	MA34	MA33	MA32	
H'FFFF FD72		MA31	MA30	MA29	MA28	MA27	MA26	MA25	MA24	
H'FFFF FD73		MA23	MA22	MA21	MA20	MA19	MA18	MA17	MA16	
H'FFFF FD74	MALR	—	—	—	—	—	—	—	—	
H'FFFF FD75		—	—	—	—	—	—	—	—	
H'FFFF FD76		MA15	MA14	MA13	MA12	MA11	MA10	MA9	MA8	
H'FFFF FD77		MA7	MA6	MA5	MA4	MA3	MA2	MA1	MA0	
H'FFFF FD78	RFLR	—	—	—	—	—	—	—	—	
H'FFFF FD79		—	—	—	—	—	—	—	—	
H'FFFF FD7A		—	—	—	—	RFL11	RFL10	RFL9	RFL8	
H'FFFF FD7B		RFL7	RFL6	RFL5	RFL4	RFL3	RFL2	RFL1	RFL0	
H'FFFF FD7C	PSR	—	—	—	—	—	—	—	—	
H'FFFF FD7D		—	—	—	—	—	—	—	—	
H'FFFF FD7E		—	—	—	—	—	—	—	—	
H'FFFF FD7F		—	—	—	—	—	—	—	LMON	

Address	Register Name	Bit Names								Module
		Bit 7	Bit 6	Bit 5	Bit 4	Bit 3	Bit 2	Bit 1	Bit 0	
H'FFFF FD80	TROCR	—	—	—	—	—	—	—	—	EtherC
H'FFFF FD81		—	—	—	—	—	—	—	—	
H'FFFF FD82		TROC15	TROC14	TROC13	TROC12	TROC11	TROC10	TROC9	TROC8	
H'FFFF FD83		TROC7	TROC6	TROC5	TROC4	TROC3	TROC2	TROC1	TROC0	
H'FFFF FD84	CDCR	—	—	—	—	—	—	—	—	
H'FFFF FD85		—	—	—	—	—	—	—	—	
H'FFFF FD86		COLDC15	COLDC14	COLDC13	COLDC12	COLDC11	COLDC10	COLDC9	COLDC8	
H'FFFF FD87		COLDC7	COLDC6	COLDC5	COLDC4	COLDC3	COLDC2	COLDC1	COLDC0	
H'FFFF FD88	LCCR	—	—	—	—	—	—	—	—	
H'FFFF FD89		—	—	—	—	—	—	—	—	
H'FFFF FD8A		LCC15	LCC14	LCC13	LCC12	LCC11	LCC10	LCC9	LCC8	
H'FFFF FD8B		LCC7	LCC6	LCC5	LCC4	LCC3	LCC2	LCC1	LCC0	
H'FFFF FD8C	CNDCR	—	—	—	—	—	—	—	—	
H'FFFF FD8D		—	—	—	—	—	—	—	—	
H'FFFF FD8E		CNDC15	CNDC14	CNDC13	CNDC12	CNDC11	CNDC10	CNDC9	CNDC8	
H'FFFF FD8F		CNDC7	CNDC6	CNDC5	CNDC4	CNDC3	CNDC2	CNDC1	CNDC0	
H'FFFF FD90	IFLCR	—	—	—	—	—	—	—	—	
H'FFFF FD91		—	—	—	—	—	—	—	—	
H'FFFF FD92		IFLC15	IFLC14	IFLC13	IFLC12	IFLC11	IFLC10	IFLC9	IFLC8	
H'FFFF FD93		IFLC7	IFLC6	IFLC5	IFLC4	IFLC3	IFLC2	IFLC1	IFLC0	
H'FFFF FD94	CEFCR	—	—	—	—	—	—	—	—	
H'FFFF FD95		—	—	—	—	—	—	—	—	
H'FFFF FD96		CEFC15	CEFC14	CEFC13	CEFC12	CEFC11	CEFC10	CEFC9	CEFC8	
H'FFFF FD97		CEFC7	CEFC6	CEFC5	CEFC4	CEFC3	CEFC2	CEFC1	CEFC0	
H'FFFF FD98	FRECR	—	—	—	—	—	—	—	—	
H'FFFF FD99		—	—	—	—	—	—	—	—	
H'FFFF FD9A		FREC15	FREC14	FREC13	FREC12	FREC11	FREC10	FREC9	FREC8	
H'FFFF FD9B		FREC7	FREC6	FREC5	FREC4	FREC3	FREC2	FREC1	FREC0	
H'FFFF FD9C	TSFCR	—	—	—	—	—	—	—	—	
H'FFFF FD9D		—	—	—	—	—	—	—	—	
H'FFFF FD9E		TSFC15	TSFC14	TSFC13	TSFC12	TSFC11	TSFC10	TSFC9	TSFC8	
H'FFFF FD9F		TSFC7	TSFC6	TSFC5	TSFC4	TSFC3	TSFC2	TSFC1	TSFC0	

Address	Register		Bit Names							Module
	Name	Bit 7	Bit 6	Bit 5	Bit 4	Bit 3	Bit 2	Bit 1	Bit 0	
H'FFFF FDA0	TLFRCR	—	—	—	—	—	—	—	—	EtherC
H'FFFF FDA1		—	—	—	—	—	—	—	—	
H'FFFF FDA2	TLFCR	TLFC15	TLFC14	TLFC13	TLFC12	TLFC11	TLFC10	TLFC9	TLFC8	
H'FFFF FDA3		TLFC7	TLFC6	TLFC5	TLFC4	TLFC3	TLFC2	TLFC1	TLFC0	
H'FFFF FDA4	RFCR	—	—	—	—	—	—	—	—	
H'FFFF FDA5		—	—	—	—	—	—	—	—	
H'FFFF FDA6	RFCR	RFC15	RFC14	RFC13	RFC12	RFC11	RFC10	RFC9	RFC8	
H'FFFF FDA7		RFC7	RFC6	RFC5	RFC4	RFC3	RFC2	RFC1	RFC0	
H'FFFF FDA8	MAFCR	—	—	—	—	—	—	—	—	
H'FFFF FDA9		—	—	—	—	—	—	—	—	
H'FFFF FDAA	MAFCR	MAFC15	MAFC14	MAFC13	MAFC12	MAFC11	MAFC10	MAFC9	MAFC8	
H'FFFF FDAB		MAFC7	MAFC6	MAFC5	MAFC4	MAFC3	MAFC2	MAFC1	MAFC0	
H'FFFF FDAC to H'FFFF FDB3	—	—	—	—	—	—	—	—	—	—
H'FFFF FDB4	SCDCR	COSDC 31	COSDC 30	COSDC 29	COSDC 28	COSDC 27	COSDC 26	COSDC 25	COSDC 24	EtherC
H'FFFF FDB5		COSDC 23	COSDC 22	COSDC 21	COSDC 20	COSDC 19	COSDC 18	COSDC 17	COSDC 16	
H'FFFF FDB6		COSDC 15	COSDC 14	COSDC 13	COSDC 12	COSDC 11	COSDC 10	COSDC9	COSDC8	
H'FFFF FDB7		COSDC7	COSDC6	COSDC5	COSDC4	COSDC3	COSDC2	COSDC1	COSDC0	
H'FFFF FDB8 to H'FFFF FE0F	—	—	—	—	—	—	—	—	—	—
H'FFFFFFE10	TIER	ICIE	—	—	—	OCIAE	OCIBE	OVIE	—	FRT
H'FFFFFFE11	FTCSR	ICF	—	—	—	OCFA	OCFB	OVF	CCLRA	
H'FFFFFFE12	FRC	H								
H'FFFFFFE13	FRC	L								
H'FFFFFFE14	OCRA	H								
	OCRB	H								
H'FFFFFFE15	OCRA	L								
	OCRB	L								
H'FFFFFFE16	TCR	IEDG	—	—	—	—	—	CKS1	CKS0	
H'FFFFFFE17	TOCR	—	—	—	OCRS	—	—	OLVLA	OLVLB	
H'FFFFFFE18	FICR	H								
H'FFFFFFE19	FICR	L								
H'FFFFFFE1A to H'FFFFFFE3F	—	—	—	—	—	—	—	—	—	—

Address	Register Name	Bit Names								Module
		Bit 7	Bit 6	Bit 5	Bit 4	Bit 3	Bit 2	Bit 1	Bit 0	
H'FFFFFFE40	IPRD	TPU0IP3	TPU0IP2	TPU0IP1	TPU0IP0	TPU1IP3	TPU1IP2	TPU1IP1	TPU1IP0	INTC
H'FFFFFFE41		TPU2IP3	TPU2IP2	TPU2IP1	TPU2IP0	SCF1IP3	SCF1IP2	SCF1IP1	SCF1IP0	
H'FFFFFFE42	VCRE	—	TG0AV6	TG0AV5	TG0AV4	TG0AV3	TG0AV2	TG0AV1	TG0AV0	
H'FFFFFFE43		—	TG0BV6	TG0BV5	TG0BV4	TG0BV3	TG0BV2	TG0BV1	TG0BV0	
H'FFFFFFE44	VCRF	—	TG0CV6	TG0CV5	TG0CV4	TG0CV3	TG0CV2	TG0CV1	TG0CV0	
H'FFFFFFE45		—	TG0DV6	TG0DV5	TG0DV4	TG0DV3	TG0DV2	TG0DV1	TG0DV0	
H'FFFFFFE46	VCRG	—	TC0VV6	TC0VV5	TC0VV4	TC0VV3	TC0VV2	TC0VV1	TC0VV0	
H'FFFFFFE47		—	—	—	—	—	—	—	—	
H'FFFFFFE48	VCRH	—	TG1AV6	TG1AV5	TG1AV4	TG1AV3	TG1AV2	TG1AV1	TG1AV0	
H'FFFFFFE49		—	TG1BV6	TG1BV5	TG1BV4	TG1BV3	TG1BV2	TG1BV1	TG1BV0	
H'FFFFFFE4A	VCRI	—	TC1VV6	TC1VV5	TC1VV4	TC1VV3	TC1VV2	TC1VV1	TC1VV0	
H'FFFFFFE4B		—	TC1UV6	TC1UV5	TC1UV4	TC1UV3	TC1UV2	TC1UV1	TC1UV0	
H'FFFFFFE4C	VCRJ	—	TG2AV6	TG2AV5	TG2AV4	TG2AV3	TG2AV2	TG2AV1	TG2AV0	
H'FFFFFFE4D		—	TG2BV6	TG2BV5	TG2BV4	TG2BV3	TG2BV2	TG2BV1	TG2BV0	
H'FFFFFFE4E	VCRK	—	TC2VV6	TC2VV5	TC2VV4	TC2VV3	TC2VV2	TC2VV1	TC2VV0	
H'FFFFFFE4F		—	TC2UV6	TC2UV5	TC2UV4	TC2UV3	TC2UV2	TC2UV1	TC2UV0	
H'FFFFFFE50	VCRL	—	SER1V6	SER1V5	SER1V4	SER1V3	SER1V2	SER1V1	SER1V0	
H'FFFFFFE51		—	SRX1V6	SRX1V5	SRX1V4	SRX1V3	SRX1V2	SRX1V1	SRX1V0	
H'FFFFFFE52	VCRM	—	SBR1V6	SBR1V5	SBR1V4	SBR1V3	SBR1V2	SBR1V1	SBR1V0	
H'FFFFFFE53		—	STX1V6	STX1V5	STX1V4	STX1V3	STX1V2	STX1V1	STX1V0	
H'FFFFFFE54	VCRN	—	SER2V6	SER2V5	SER2V4	SER2V3	SER2V2	SER2V1	SER2V0	
H'FFFFFFE55		—	SRX2V6	SRX2V5	SRX2V4	SRX2V3	SRX2V2	SRX2V1	SRX2V0	
H'FFFFFFE56	VCRO	—	SBR2V6	SBR2V5	SBR2V4	SBR2V3	SBR2V2	SBR2V1	SBR2V0	
H'FFFFFFE57		—	STX2V6	STX2V5	STX2V4	STX2V3	STX2V2	STX2V1	STX2V0	
H'FFFFFFE58 to H'FFFFFFE5F	—	—	—	—	—	—	—	—	—	
H'FFFFFFE60	IPRB	E-DMACIP3	E-DMACIP2	E-DMACIP1	E-DMACIP0	FRTIP3	FRTIP2	FRTIP1	FRTIP0	INTC
H'FFFFFFE61		—	—	—	—	—	—	—	—	
H'FFFFFFE62	VCRA	—	EINV6	EINV5	EINV4	EINV3	EINV2	EINV1	EINV0	
H'FFFFFFE63		—	—	—	—	—	—	—	—	
H'FFFFFFE64	VCRB	—	—	—	—	—	—	—	—	
H'FFFFFFE65		—	—	—	—	—	—	—	—	
H'FFFFFFE66	VCRC	—	FICV6	FICV5	FICV4	FICV3	FICV2	FICV1	FICV0	
H'FFFFFFE67		—	FOCV6	FOCV5	FOCV4	FOCV3	FOCV2	FOCV1	FOCV0	
H'FFFFFFE68	VCRD	—	FOVV6	FOVV5	FOVV4	FOVV3	FOVV2	FOVV1	FOVV0	
H'FFFFFFE69		—	—	—	—	—	—	—	—	

Address	Register Name	Bit Names								Module
		Bit 7	Bit 6	Bit 5	Bit 4	Bit 3	Bit 2	Bit 1	Bit 0	
H'FFFFFFE6A to H'FFFFFFE70	—	—	—	—	—	—	—	—	—	—
H'FFFFFFE71	DRCR0	—	—	—	RS4	RS3	RS2	RS1	RS0	DMAC
H'FFFFFFE72	DRCR1	—	—	—	RS4	RS3	RS2	RS1	RS0	
H'FFFFFFE73 to H'FFFFFFE7F	—	—	—	—	—	—	—	—	—	—
H'FFFFFFE80	WTCSR	OVF	WT/IT	TME	—	—	CKS2	CKS1	CKS0	WDT
H'FFFFFFE81	WTCNT									
H'FFFFFFE82	—	—	—	—	—	—	—	—	—	
H'FFFFFFE83	RSTCSR	WOVF	RSTE	RSTS	—	—	—	—	—	
H'FFFFFFE84 to H'FFFFFFE8F	—	—	—	—	—	—	—	—	—	—
H'FFFFFFE90	FMR	PLL2ST	PLL1ST	CKIOST	—	FR3	FR2	FR1	FR0	On-chip oscillation circuit
H'FFFFFFE91	SBYCR1	SBY	HIZ	MSTP5	MSTP4	MSTP3	—	MSTP1	—	Power-down state
H'FFFFFFE92	CCR	W1	W0	WB	CP	TW	OD	ID	CE	CACHE
H'FFFFFFE93	SBYCR2	—	—	MSTP11	MSTP10	MSTP9	MSTP8	MSTP7	MSTP6	Power-down state
H'FFFFFFE94 to H'FFFFFFEBF	—	—	—	—	—	—	—	—	—	—
H'FFFFFFEC0	IPRE	SCF2IP3	SCF2IP2	SCF2IP1	SCF2IP0	SIOFIP3	SIOFIP2	SIOFIP1	SIOFIP0	INTC
H'FFFFFFEC1		SIO1IP3	SIO1P2	SIO2P1	SIO1IP0	SIO2IP3	SIO2IP2	SIO2IP1	SIO2IP0	
H'FFFFFFEC2	VCRP	—	RER0V6	RER0V5	RER0V4	RER0V3	RER0V2	RER0V1	RER0V0	
H'FFFFFFEC3		—	TER0V6	TER0V5	TER0V4	TER0V3	TER0V2	TER0V1	TER0V0	
H'FFFFFFEC4	VCRQ	—	RDF0V6	RDF0V5	RDF0V4	RDF0V3	RDF0V2	RDF0V1	RDF0V0	
H'FFFFFFEC5		—	TDE0V6	TDE0V5	TDE0V4	TDE0V3	TDE0V2	TDE0V1	TDE0V0	
H'FFFFFFEC6	VCRR	—	RER1V6	RER1V5	RER1V4	RER1V3	RER1V2	RER1V1	RER1V0	
H'FFFFFFEC7		—	TER1V6	TER1V5	TER1V4	TER1V3	TER1V2	TER1V1	TER1V0	
H'FFFFFFEC8	VCRS	—	RDF1V6	RDF1V5	RDF1V4	RDF1V3	RDF1V2	RDF1V1	RDF1V0	
H'FFFFFFEC9		—	TDE1V6	TDE1V5	TDE1V4	TDE1V3	TDE1V2	TDE1V1	TDE1V0	
H'FFFFFFECA	VCRT	—	RER2V6	RER2V5	RER2V4	RER2V3	RER2V2	RER2V1	RER2V0	
H'FFFFFFECB		—	TER2V6	TER2V5	TER2V4	TER2V3	TER2V2	TER2V1	TER2V0	
H'FFFFFFECC	VCRU	—	RDF2V6	RDF2V5	RDF2V4	RDF2V3	RDF2V2	RDF2V1	RDF2V0	
H'FFFFFFECD		—	TDE2V6	TDE2V5	TDE2V4	TDE2V3	TDE2V2	TDE2V1	TDE2V0	
H'FFFFFFECE to H'FFFFFFEDF	—	—	—	—	—	—	—	—	—	—

Address	Register Name	Bit Names								Module
		Bit 7	Bit 6	Bit 5	Bit 4	Bit 3	Bit 2	Bit 1	Bit 0	
H'FFFFFFE0	ICR	NMIL	—	—	—	—	—	—	NMIE	INTC
H'FFFFFFE1		—	—	—	—	—	—	EXIMD	VECMD	
H'FFFFFFE2	IPRA	—	—	—	—	DMACIP3	DMACIP2	DMACIP1	DMACIP0	
H'FFFFFFE3		WDTIP3	WDTIP2	WDTIP1	WDTIP0	—	—	—	—	
H'FFFFFFE4	VCRWDT	—	WITV6	WITV5	WITV4	WITV3	WITV2	WITV1	WITV0	
H'FFFFFFE5		—	BCMV6	BCMV5	BCMV4	BCMV3	BCMV2	BCMV1	BCMV0	
H'FFFFFFE6	IPRC	IRQ0IP3	IRQ0IP2	IRQ0IP1	IRQ0IP0	IRQ1IP3	IRQ1IP2	IRQ1IP1	IRQ1IP0	
H'FFFFFFE7		IRQ2IP3	IRQ2IP2	IRQ2IP1	IRQ2IP0	IRQ3IP3	IRQ3IP2	IRQ3IP1	IRQ3IP0	
H'FFFFFFE8	IRQCSR	IRQ31S	IRQ30S	IRQ21S	IRQ20S	IRQ11S	IRQ10S	IRQ01S	IRQ00S	
H'FFFFFFE9		IRL3PS	IRL2PS	IRL1PS	IRL0PS	IRQ3F	IRQ2F	IRQ1F	IRQ0F	
H'FFFFFFEA to H'FFFFFFEF	—	—	—	—	—	—	—	—	—	—
H'FFFF FF00	BARAH	BAA31	BAA30	BAA29	BAA28	BAA27	BAA26	BAA25	BAA24	UBC
H'FFFF FF01		BAA23	BAA22	BAA21	BAA20	BAA19	BAA18	BAA17	BAA16	
H'FFFF FF02	BARAL	BAA15	BAA14	BAA13	BAA12	BAA11	BAA10	BAA9	BAA8	
H'FFFF FF03		BAA7	BAA6	BAA5	BAA4	BAA3	BAA2	BAA1	BAA0	
H'FFFF FF04	BAMRAH	BAMA31	BAMA30	BAMA29	BAMA28	BAMA27	BAMA26	BAMA25	BAMA24	
H'FFFF FF05		BAMA23	BAMA22	BAMA21	BAMA20	BAMA19	BAMA18	BAMA17	BAMA16	
H'FFFF FF06	BAMRAL	BAMA15	BAMA14	BAMA13	BAMA12	BAMA11	BAMA10	BAMA9	BAMA8	
H'FFFF FF07		BAMA7	BAMA6	BAMA5	BAMA4	BAMA3	BAMA2	BAMA1	BAMA0	
H'FFFF FF08	BBRA	—	—	—	—	—	—	—	—	
H'FFFF FF09		CPA1	CPA0	IDA1	IDA0	RWA1	RWA0	SZA1	SZA0	
H'FFFF FF0A to H'FFFF FF0F	—	—	—	—	—	—	—	—	—	—
H'FFFF FF10	BRFR	SVF	PID2	PID1	PID0	—	—	—	—	UBC
H'FFFF FF11		DVF	—	—	—	—	—	—	—	
H'FFFF FF12 to H'FFFF FF13	—	—	—	—	—	—	—	—	—	—
H'FFFF FF14	BRSRH	BSA31	BSA30	BSA29	BSA28	BSA27	BSA26	BSA25	BSA24	UBC
H'FFFF FF15		BSA23	BSA22	BSA21	BSA20	BSA19	BSA18	BSA17	BSA16	
H'FFFF FF16	BRSRL	BSA15	BSA14	BSA13	BSA12	BSA11	BSA10	BSA9	BSA8	
H'FFFF FF17		BSA7	BSA6	BSA5	BSA4	BSA3	BSA2	BSA1	BSA0	
H'FFFF FF18	BRDRH	BDA31	BDA30	BDA29	DA28	BDA27	BDA26	BDA25	BDA24	
H'FFFF FF19		BDA23	BDA22	BDA21	BDA20	BDA19	BDA18	BDA17	BDA16	

Address	Register Name	Bit Names								Module
		Bit 7	Bit 6	Bit 5	Bit 4	Bit 3	Bit 2	Bit 1	Bit 0	
H'FFFF FF1A	BRDRL	BDA15	BDA14	BDA13	BDA12	BDA11	BDA10	BDA9	BDA8	UBC
H'FFFF FF1B		BDA7	BDA6	BDA5	BDA4	BDA3	BDA2	BDA1	BDA0	
H'FFFF FF1C to H'FFFF FF1F	—	—	—	—	—	—	—	—	—	—
H'FFFF FF20	BARBH	BAB31	BAB30	BAB29	BAB28	BAB27	BAB26	BAB25	BAB24	UBC
H'FFFF FF21		BAB23	BAB22	BAB21	BAB20	BAB19	BAB18	BAB17	BAB16	
H'FFFF FF22	BARBL	BAB15	BAB14	BAB13	BAB12	BAB11	BAB10	BAB9	BAB8	
H'FFFF FF23		BAB7	BAB6	BAB5	BAB4	BAB3	BAB2	BAB1	BAB0	
H'FFFF FF24	BAMRBH	BAMB31	BAMB30	BAMB29	BAMB28	BAMB27	BAMB26	BAMB25	BAMB24	
H'FFFF FF25		BAMB23	BAMB22	BAMB21	BAMB20	BAMB19	BAMB18	BAMB17	BAMB16	
H'FFFF FF26	BAMRBL	BAMB15	BAMB14	BAMB13	BAMB12	BAMB11	BAMB10	BAMB9	BAMB8	
H'FFFF FF27		BAMB7	BAMB6	BAMB5	BAMB4	BAMB3	BAMB2	BAMB1	BAMB0	
H'FFFF FF28	BBRB	—	—	—	—	—	—	—	—	
H'FFFF FF29		CPB1	CPB0	IDB1	IDB0	RWB1	RWB0	SZB1	SZB0	
H'FFFF FF2A to H'FFFF FF2F	—	—	—	—	—	—	—	—	—	—
H'FFFF FF30	BRCRH	CMFCA	CMFPA	—	—	PCTE	PCBA	—	—	UBC
H'FFFF FF31		CMFCB	CMFPB	—	SEQ1	SEQ0	PCBB	—	—	
H'FFFF FF32	BRCRL	CMFCC	CMFPC	ETBEC	—	DBEC	PCBC	—	—	
H'FFFF FF33		CMFCD	CMFPD	ETBED	—	DBED	PCBD	—	—	
H'FFFF FF34 to H'FFFF FF3F	—	—	—	—	—	—	—	—	—	—
H'FFFFFF40	BARCH	BAC31	BAC30	BAC29	BAC28	BAC27	BAC26	BAC25	BAC24	UBC
H'FFFFFF41		BAC23	BAC22	BAC21	BAC20	BAC19	BAC18	BAC17	BAC16	
H'FFFFFF42	BARCL	BAC15	BAC14	BAC13	BAC12	BAC11	BAC10	BAC9	BAC8	
H'FFFFFF43		BAC7	BAC6	BAC5	BAC4	BAC3	BAC2	BAC1	BAC0	
H'FFFFFF44	BAMRCH	BAMC31	BAMC30	BAMC29	BAMC28	BAMC27	BAMC26	BAMC25	BAMC24	
H'FFFFFF45		BAMC23	BAMC22	BAMC21	BAMC20	BAMC19	BAMC18	BAMC17	BAMC16	
H'FFFFFF46	BAMRCL	BAMC15	BAMC14	BAMC13	BAMC12	BAMC11	BAMC10	BAMC9	BAMC8	
H'FFFFFF47		BAMC7	BAMC6	BAMC5	BAMC4	BAMC3	BAMC2	BAMC1	BAMC0	
H'FFFFFF48	BBRC	—	—	—	—	—	—	—	—	
H'FFFFFF49		CPC1	CPC0	IDC1	IDC0	RWC1	RWC0	SZC1	SZC0	
H'FFFFFF4A to H'FFFFFF4F	—	—	—	—	—	—	—	—	—	—

Address	Register Name	Bit Names								Module
		Bit 7	Bit 6	Bit 5	Bit 4	Bit 3	Bit 2	Bit 1	Bit 0	
H'FFFF FF50	BDRCH	BDC31	BDC30	BDC29	BDC28	BDC27	BDC26	BDC25	BDC24	UBC
H'FFFF FF51		BDC23	BDC22	BDC21	BDC20	BDC19	BDC18	BDC17	BDC16	
H'FFFF FF52	BDRCL	BDC15	BDC14	BDC13	BDC12	BDC11	BDC10	BDC9	BDC8	
H'FFFF FF53		BDC7	BDC6	BDC5	BDC4	BDC3	BDC2	BDC1	BDC0	
H'FFFF FF54	BDMRCH	BDMC31	BDMC30	BDMC29	BDMC28	BDMC27	BDMC26	BDMC25	BDMC24	
H'FFFF FF55		BDMC23	BDMC22	BDMC21	BDMC20	BDMC19	BDMC18	BDMC17	BDMC16	
H'FFFF FF56	BDMRCL	BDMC15	BDMC14	BDMC13	BDMC12	BDMC11	BDMC10	BDMC9	BDMC8	
H'FFFF FF57		BDMC7	BDMC6	BDMC5	BDMC4	BDMC3	BDMC2	BDMC1	BDMC0	
H'FFFF FF58	BETRC	—	—	—	—	ETRC11	ETRC10	ETRC9	ETRC8	
H'FFFF FF59		ETRC7	ETRC6	ETRC5	ETRC4	ETRC3	ETRC2	ETRC1	ETRC0	
H'FFFF FF5A to H'FFFF FF5F	—	—	—	—	—	—	—	—	—	—
H'FFFF FF60	BARDH	BAD31	BAD30	BAD29	BAD28	BAD27	BAD26	BAD25	BAD24	UBC
H'FFFF FF61		BAD23	BAD22	BAD21	BAD20	BAD19	BAD18	BAD17	BAD16	
H'FFFF FF62	BARDL	BAD15	BAD14	BAD13	BAD12	BAD11	BAD10	BAD9	BAD8	
H'FFFF FF63		BAD7	BAD6	BAD5	BAD4	BAD3	BAD2	BAD1	BAD0	
H'FFFF FF64	BAMRDH	BAMD31	BAMD30	BAMD29	BAMD28	BAMD27	BAMD26	BAMD25	BAMD24	
H'FFFF FF65		BAMD23	BAMD22	BAMD21	BAMD20	BAMD19	BAMD18	BAMD17	BAMD16	
H'FFFF FF66	BAMRDL	BAMD15	BAMD14	BAMD13	BAMD12	BAMD11	BAMD10	BAMD9	BAMD8	
H'FFFF FF67		BAMD7	BAMD6	BAMD5	BAMD4	BAMD3	BAMD2	BAMD1	BAMD0	
H'FFFF FF68	BBRD	—	—	—	—	—	—	XYED	XYSD	
H'FFFF FF69		CPD1	CPD0	IDD1	IDD0	RWD1	RWD0	SZD1	SZD0	
H'FFFF FF6A to H'FFFF FF6F	—	—	—	—	—	—	—	—	—	—
H'FFFF FF70	BDRDH	BDD31	BDD30	BDD29	BDD28	BDD27	BDD26	BDD25	BDD24	UBC
H'FFFF FF71		BDD23	BDD22	BDD21	BDD20	BDD19	BDD18	BDD17	BDD16	
H'FFFF FF72	BDRDL	BDD15	BDD14	BDD13	BDD12	BDD11	BDD10	BDD9	BDD8	
H'FFFF FF73		BDD7	BDD6	BDD5	BDD4	BDD3	BDD2	BDD1	BDD0	
H'FFFF FF74	BDMRDH	BDMD31	BDMD30	BDMD29	BDMD28	BDMD27	BDMD26	BDMD25	BDMD24	
H'FFFF FF75		BDMD23	BDMD22	BDMD21	BDMD20	BDMD19	BDMD18	BDMD17	BDMD16	

Address	Register Name	Bit Names								Module	
		Bit 7	Bit 6	Bit 5	Bit 4	Bit 3	Bit 2	Bit 1	Bit 0		
H'FFFF FF76	BDMRDL	BDMD15	BDMD14	BDMD13	BDMD12	BDMD11	BDMD10	BDMD9	BDMD8	USB	
H'FFFF FF77		BDMD7	BDMD6	BDMD5	BDMD4	BDMD3	BDMD2	BDMD1	BDMD0		
H'FFFF FF78	BETRD	—	—	—	—	ETRD11	ETRD10	ETRD9	ETRD8		
H'FFFF FF79		ETRD7	ETRD6	ETRD5	ETRD4	ETRD3	ETRD2	ETRD1	ETRD0		
H'FFFF FF7A to H'FFFF FF7F	—	—	—	—	—	—	—	—	—	—	
H'FFFFFFF80	SAR0									DMAC	
H'FFFFFFF81											
H'FFFFFFF82											
H'FFFFFFF83											
H'FFFFFFF84		DAR0									
H'FFFFFFF85											
H'FFFFFFF86											
H'FFFFFFF87											
H'FFFFFFF88	TCR0	—	—	—	—	—	—	—	—		
H'FFFFFFF89											
H'FFFFFFF8A											
H'FFFFFFF8B											
H'FFFFFFF8C	CHCR0	—	—	—	—	—	—	—	—		
H'FFFFFFF8D		—	—	—	—	—	—	—	—		
H'FFFFFFF8E		DM1	DM0	SM1	SM0	TS1	TS0	AR	AM		
H'FFFFFFF8F		AL	DS	DL	TB	TA	IE	TE	DE		
H'FFFFFFF90	SAR1										
H'FFFFFFF91											
H'FFFFFFF92											
H'FFFFFFF93											
H'FFFFFFF94	DAR1										
H'FFFFFFF95											
H'FFFFFFF96											
H'FFFFFFF97											
H'FFFFFFF98	TCR1	—	—	—	—	—	—	—	—		
H'FFFFFFF99											
H'FFFFFFF9A											
H'FFFFFFF9B											

Address	Register Name	Bit Names								Module
		Bit 7	Bit 6	Bit 5	Bit 4	Bit 3	Bit 2	Bit 1	Bit 0	
H'FFFFFF9C	CHCR1	—	—	—	—	—	—	—	—	DMAC
H'FFFFFF9D		—	—	—	—	—	—	—	—	
H'FFFFFF9E	VCRDMA0	DM1	DM0	SM1	SM0	TS1	TS0	AR	AM	
H'FFFFFF9F		AL	DS	DL	TB	TA	IE	TE	DE	
H'FFFFFFA0		—	—	—	—	—	—	—	—	
H'FFFFFFA1	VCRDMA1	—	—	—	—	—	—	—	—	DMAC
H'FFFFFFA2		—	—	—	—	—	—	—	—	
H'FFFFFFA3		VC7	VC6	VC5	VC4	VC3	VC2	VC1	VC0	
H'FFFFFFA4 to H'FFFFFFA7		—	—	—	—	—	—	—	—	
H'FFFFFFA8	DMAOR	—	—	—	—	—	—	—	—	DMAC
H'FFFFFFA9		—	—	—	—	—	—	—	—	
H'FFFFFFAA		—	—	—	—	—	—	—	—	
H'FFFFFFAB		VC7	VC6	VC5	VC4	VC3	VC2	VC1	VC0	
H'FFFFFFAC to H'FFFFFFAF	WCR2	—	—	—	—	—	—	—	—	BSC
H'FFFFFFB0		—	—	—	—	—	—	—	—	
H'FFFFFFB1		—	—	—	—	—	—	—	—	
H'FFFFFFB2		—	—	—	—	—	—	—	—	
H'FFFFFFB3		—	—	—	—	PR	AE	NMIF	DME	
H'FFFFFFB4 to H'FFFFFFBF	WCR3	—	—	—	—	—	—	—	—	BSC
H'FFFFFFC0		A4WD1	A4WD0	—	A4WM	A3WM	A2WM	A1WM	A0WM	
H'FFFFFFC1		—	—	—	—	IW41	IW40	W41	W40	
H'FFFFFFC2 to H'FFFFFFC3	BCR1	—	—	—	—	—	—	—	—	BSC
H'FFFFFFC4		—	—	A4SW2	A4SW1	A4SW0	—	A4HW1	A4HW0	
H'FFFFFFC5	BCR1	A3SHW1	A3SHW0	A2SHW1	A2SHW0	A1SHW1	A1SHW0	A0SHW1	A0SHW0	BSC
H'FFFFFFC6 to H'FFFFFFDF		—	—	—	—	—	—	—	—	
H'FFFFFFE0		—	—	—	—	—	—	—	—	
H'FFFFFFE1	BCR1	A1LW1	A1LW0	A0LW1	A0LW0	A4ENDIA N	DRAM2	DRAM1	DRAM0	BSC
H'FFFFFFE2 to H'FFFFFFE3		—	—	—	—	—	—	—	—	

Address	Register Name	Bit Names								Module
		Bit 7	Bit 6	Bit 5	Bit 4	Bit 3	Bit 2	Bit 1	Bit 0	
H'FFFFFFE4	BCR2	—	—	—	—	—	—	A4SZ1	A4SZ0	BSC
H'FFFFFFE5		A3SZ1	A3SZ0	A2SZ1	A2SZ0	A1SZ1	A1SZ0	—	—	
H'FFFFFFE6 to H'FFFFFFE7	—	—	—	—	—	—	—	—	—	—
H'FFFFFFE8	WCR1	IW31	IW30	IW21	IW20	IW11	IW10	IW01	IW00	BSC
H'FFFFFFE9		W31	W30	W21	W20	W11	W10	W01	W00	
H'FFFFFFEA to H'FFFFFFEB	—	—	—	—	—	—	—	—	—	—
H'FFFFFFEC	MCR	TRP0	RCD0	TRWL0	TRAS1	TRAS0	BE	RASD	TRWL1	BSC
H'FFFFFFED		AMX2	SZ	AMX1	AMX0	RFSH	RMD	TRP1	RCD1	
H'FFFFFFEE to H'FFFFFFEF	—	—	—	—	—	—	—	—	—	—
H'FFFFFFF0	RTCSR	—	—	—	—	—	—	—	—	BSC
H'FFFFFFF1		CMF	CMIE	CKS2	CKS1	CKS0	RRC2	RRC1	RRC0	
H'FFFFFFF2 to H'FFFFFFF3	—	—	—	—	—	—	—	—	—	—
H'FFFFFFF4	RTCNT	—	—	—	—	—	—	—	—	BSC
H'FFFFFFF5		—	—	—	—	—	—	—	—	
H'FFFFFFF6 to H'FFFFFFF7	—	—	—	—	—	—	—	—	—	—
H'FFFFFFF8	RTCOR	—	—	—	—	—	—	—	—	BSC
H'FFFFFFF9		—	—	—	—	—	—	—	—	
H'FFFFFFFA to H'FFFFFFFB	—	—	—	—	—	—	—	—	—	—
H'FFFFFFFC	BCR3	—	—	—	—	A4LW2	AHLW2	A1LW2	A0LW2	BSC
H'FFFFFFFD		DSWW1	DSWW0	—	—	—	BASEL	EDO	BWE	
H'FFFFFFFE to H'FFFFFFF	—	—	—	—	—	—	—	—	—	—

Appendix B Pin States

B.1 Pin States in Reset, Power-Down State, and Bus-Released State

Pin Type	Pin Name	Pin State						Bus-Released State
		Power-On Reset	Manual Reset		Power-Down State			
			Bus Acquired	Bus Released	Standby Mode (HIZ = 0)	Standby Mode (HIZ = 1)	Sleep Mode	
Bus control	A24–A0	O	O	Z	Z	Z	O	Z
	D31–D0	Z	IO	Z	Z	Z	IO	Z
	$\overline{\text{CS4}}\text{--}\overline{\text{CS0}}$	H	O	Z	H	H	H	Z
	RD/W $\overline{\text{R}}$	H	O	Z	H	H	H	Z
	$\overline{\text{RAS}}$	H	O	Z	H	H	H	Z
	$\overline{\text{CAS/OE}}$	H	O	Z	H	H	H	Z
	$\overline{\text{WAIT}}$	Z	I	Z	Z	Z	I	Ignored
	$\overline{\text{BS}}$	H	O	Z	H	H	H	Z
	$\overline{\text{RD}}$	H	O	Z	H	H	H	Z
	$\overline{\text{BGR}}$	H	O	O	H	H	O	O
	$\overline{\text{BRLS}}$	Z	I	I	Z	Z	I	I
	CKE	H	O	H	O	O	O	H
	$\overline{\text{DQMUU/WE3}}$	H	O	Z	H	H	H	Z
	$\overline{\text{DQMUL/WE2}}$	H	O	Z	H	H	H	Z
	$\overline{\text{DQMLU/WE1}}$	H	O	Z	H	H	H	Z
	$\overline{\text{DQMLL/WE0}}$	H	O	Z	H	H	H	Z
	REFOUT	L	O	O	L	Z	O	O
	$\overline{\text{CAS3}}\text{--}\overline{\text{CAS0}}$	H	O	Z	H	H	H	Z
	$\overline{\text{BH}}$	H	O	Z	H	H	H	Z
	$\overline{\text{BUSHiZ}}$	Z	I	Z	Z	Z	I	Ignored
Interrupt	NMI	I	I	I	I	I	I	I
	$\overline{\text{IRL3}}\text{--}\overline{\text{IRL0}}$	Z	Z	Z	I	I	I	I
	$\overline{\text{IVECF}}$	H	H	H	H	Z	H	H

Pin State

Pin Type	Pin Name	Pin State						
		Power-On Reset	Manual Reset		Power-Down State			Bus-Released State
			Bus Acquired	Bus Released	Standby Mode (HIZ = 0)	Standby Mode (HIZ = 1)	Sleep Mode	
Clock	XTAL	O*	O*	O*	O*	O*	O*	O*
	EXTAL	I*	I*	I*	I*	I*	I*	I*
	CKIO	IO*	IO*	IO*	IO*	IO*	IO*	IO*
	$\overline{\text{CKPACK}}$	H	H	H	H	H	H	H
	$\overline{\text{CKPREQ/CKM}}$	I	I	I	I	I	I	I
	PLLCAP2, PLLCAP1	IO	IO	IO	IO	IO	IO	IO
DMAC	DREQ1, DREQ0	Z	Z	Z	Z	Z	I	I
	DACK1, DACK0	H	H	H	K	Z	O	O
System control	$\overline{\text{RES}}$	I	I	I	I	I	I	I
	MD4–MD0	I	I	I	I	I	I	I
Port,	PB15/SCK1	Z	IO/Z	IO/Z	K	Z	IO	IO
Internal	PB14/RXD1	Z	IO/Z	IO/Z	K	Z	IO/I	IO/I
peripheral	PB13/TXD1	Z	IO/Z	IO/Z	K	Z	IO/O	IO/O
module	PB12/SRCK2/ $\overline{\text{RTS}}$ / STATS1	Z	IO/Z/Z/O	IO/Z/Z/O	K/K/K/O	Z	IO/I/O/O	IO/I/O/O
	PB11/SRS2/ $\overline{\text{CTS}}$ / STATS0	Z	IO/Z/Z/O	IO/Z/Z/O	K/K/K/O	Z	IO/I/I/O	IO/I/I/O
	PB10/SRXD2/TIOCA1	Z	IO/Z/Z	IO/Z/Z	K/K/K	Z	IO/I/O	IO/I/O
	PB9/STCK2/TIOCB1, TCLKC	Z	IO/Z/Z	IO/Z/Z	K/K/K	Z	IO/I/O	IO/I/O
	PB8/STS2/TIOCA2	Z	IO/Z/Z	IO/Z/Z	K/K/K	Z	IO/O/O	IO/O/O
	PB7/STXD2/TIOCB2, TCLKD	Z	IO/Z/Z	IO/Z/Z	K/K/K	Z	IO/O/O	IO/O/O
	PB6/SRCK1/SCK2	Z	IO/Z/Z	IO/Z/Z	K/K/K	Z	IO/I/O	IO/I/O
	PB5/SRS1/RXD2	Z	IO/Z/Z	IO/Z/Z	K/K/K	Z	IO/I/I	IO/I/I
	PB4/SRXD1/TXD2	Z	IO/Z/Z	IO/Z/Z	K/K/K	Z	IO/I/O	IO/I/O
	PB3/STCK1/TIOCA0	Z	IO/Z/Z	IO/Z/Z	K/K/K	Z	IO/I/O	IO/I/O
PB2/STS1/TIOCB0	Z	IO/Z/Z	IO/Z/Z	K/K/K	Z	IO/O/O	IO/O/O	
PB1/STXD1/TIOCC0, TCLKA	Z	IO/Z/Z	IO/Z/Z	K/K/K	Z	IO/O/O	IO/O/O	

Pin State

Pin Type	Pin Name	Pin State						
		Power-On Reset	Manual Reset		Power-Down State			Bus-Released State
			Bus Acquired	Bus Released	Standby Mode (HIZ = 0)	Standby Mode (HIZ = 1)	Sleep Mode	
Port, Internal	PB0/TIOCD0, TCLKB/WOL	Z	IO/Z/O	IO/Z/O	K/K/O	Z	IO/IO/O	IO/IO/O
peripheral module	PA13/SRCK0	Z	IO/Z	IO/Z	K/K	Z	IO/I	IO/I
	PA12/SRS0	Z	IO/Z	IO/Z	K/K	Z	IO/I	IO/I
	PA11/SRXD0	Z	IO/Z	IO/Z	K/K	Z	IO/I	IO/I
	PA10/STCK0	Z	IO/Z	IO/Z	K/K	Z	IO/I	IO/I
	PA9/STS0	Z	IO/Z	IO/Z	K/K	Z	IO/IO	IO/IO
	PA8/STXD0	Z	IO/Z	IO/Z	K/K	Z	IO/O	IO/O
	WDTOVF/PA7	H	H/IO	H/IO	O/K	O/Z	O/IO	O/IO
	PA6/FTCI	Z	IO/Z	IO/Z	K	Z	IO/I	IO/I
	PA5/FTI	Z	IO/Z	IO/Z	K	Z	IO/I	IO/I
	PA4/FTOA	Z	IO/L	IO/L	K	Z	IO/O	IO/O
	CKPO/FTOB	H	H/L	H/L	K	Z	O/O	O/O
	PA2/LNKSTA	Z	IO/I	IO/I	K	Z	IO/I	IO/I
	PA1/EXOUT	Z	IO/O	IO/O	K	Z	IO/O	IO/O
	PA0/CAMSEN	Z	IO/I	IO/I	K	Z	IO/I	IO/I
	HUDI	TRST	I	I	I	I	I	I
TCK		I	I	I	I	I	I	I
TMS		I	I	I	I	I	I	I
TDI		I	I	I	I	I	I	I
TDO		O	O	O	O	O	O	O
ASEMODE		I	I	I	I	I	I	I

Pin Type	Pin Name	Pin State						
		Power-On Reset	Manual Reset		Power-Down State			Bus-Released State
			Bus Acquired	Bus Released	Standby Mode (HIZ = 0)	Standby Mode (HIZ = 1)	Sleep Mode	
EtherC	TX-CLK	I	I	I	I	I	I	I
	TX-EN	O	O	O	O	O	O	O
	TX-ER	O	O	O	O	O	O	O
	ETXD-ETXD0	O	O	O	O	O	O	O
	CRS	I	I	I	I	I	I	I
	COL	I	I	I	I	I	I	I
	MDC	O	O	O	O	O	O	O
	MDIO	IO	IO	IO	IO	IO	IO	IO
	RX-CLK	I	I	I	I	I	I	I
	RX-DV	I	I	I	I	I	I	I
	RX-ER	I	I	I	I	I	I	I
	ERXD-ERXD0	I	I	I	I	I	I	I

I: Input

O: Output

H: High-level output

L: Low-level output

Z: High-impedance state

K: Input pins are in the high-impedance state; output pins maintain their previous state.

Notes: In sleep mode, if the DMAC is operating the address/data bus and bus control signals vary according to the operation of the DMAC. (The same applies when refreshing is performed.)

* Depends on the clock mode (CKPREQ \bar{N} , MD2-MD0 setting).

Appendix C Product Lineup

Table C.1 SH7616 Product Lineup

Abbreviation	Voltage	Operating Frequency	Mark Code	Package
SH7616	3.3 V	62.5 MHz	HD6417616ARF	FP-208C

SH7616 Hardware Manual

Publication Date: 1st Edition, November 2001

Published by: Business Planning Division
Semiconductor & Integrated Circuits
Hitachi, Ltd.

Edited by: Technical Documentation Group
Hitachi Kodaira Semiconductor Co., Ltd.

Copyright © Hitachi, Ltd., 2001. All rights reserved. Printed in Japan.