

HD74AC112/HD74ACT112

Dual JK Negative Edge-Triggered Flip-Flop

HITACHI

ADE-205-364 (Z)
1st. Edition
Sep. 2000

Description

The HD74AC112/HD74ACT112 features individual J, K, Clock and asynchronous Set and Clear inputs to each flip-flop. When the clock goes High, the inputs are enabled and data will be accepted. The logic level of the J and K inputs may change when the clock is High and the bistable will perform according to the Truth Table as long as minimum setup and hold times are observed. Input data is transferred to the outputs on the falling edge of the clock pulse.

Features

- Outputs Source/Sink 24 mA
- HD74ACT112 has TTL-Compatible Inputs

Pin Arrangement

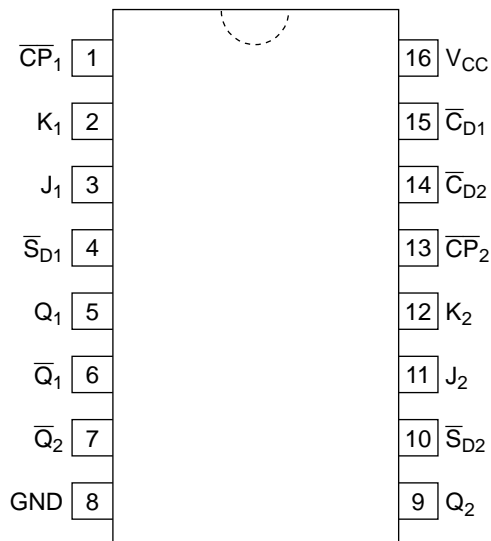

(Top view)

Logic Symbol

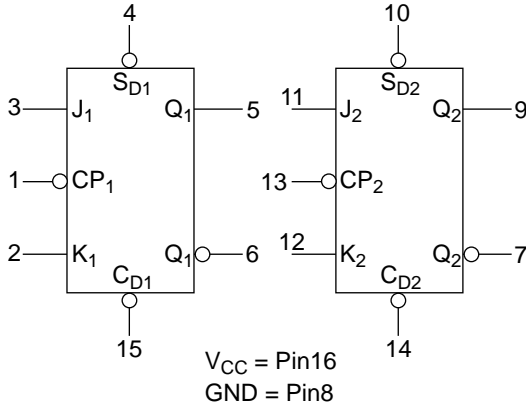

Pin Names

- J_1, J_2, K_1, K_2 Data Inputs
- $\overline{CP}_1, \overline{CP}_2$ Clock Pulse Inputs (Active Falling Edge)
- $\overline{C}_{D1}, \overline{C}_{D2}$ Direct Clear Inputs (Active Low)
- $\overline{S}_{D1}, \overline{S}_{D2}$ Direct Set Inputs (Active Low)
- $Q_1, Q_2, \overline{Q}_1, \overline{Q}_2$ Outputs

Asynchronous Inputs:

- Low input to \overline{S}_D sets Q to High level
- Low input to \overline{C}_D sets Q to Low level
- Clear and Set are independent of clock
- Simultaneous Low on \overline{C}_D and \overline{S}_D makes both Q and \overline{Q} High

Truth Table

Inputs		Outputs
@ t_n		@ t_{n+1}
J	K	Q
L	L	Q _n
L	H	L
H	L	H
H	H	Q _n

t_n : Bit time before clock pulse.

t_{n+1} : Bit time after clock pulse.

H : High Voltage Level

L : Low Voltage Level

Logic Diagram

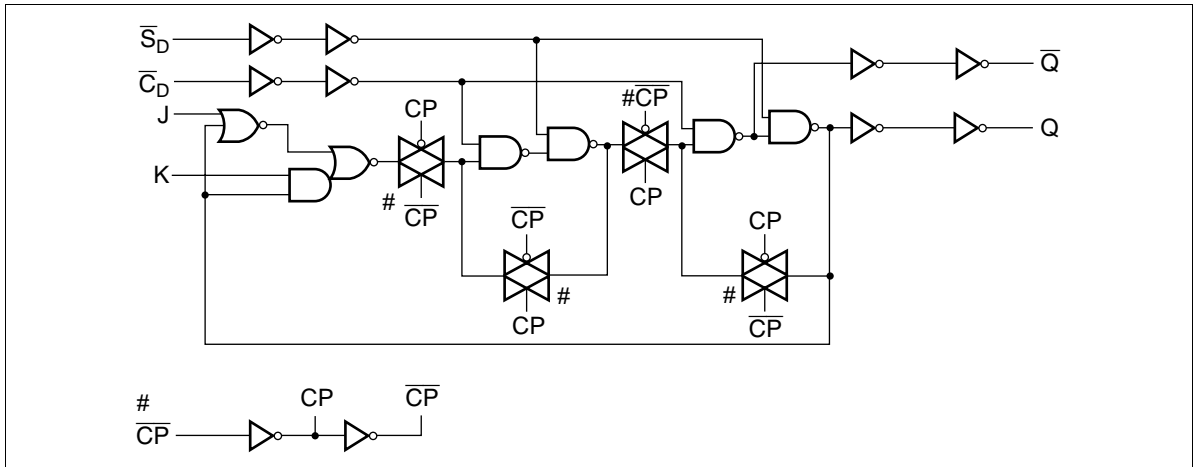

DC Characteristics (unless otherwise specified)

Item	Symbol	Max	Unit	Condition
Maximum quiescent supply current	I_{CC}	40	μA	$V_{IN} = V_{CC}$ or ground, $V_{CC} = 5.5 V$, $T_a = \text{Worst case}$
Maximum quiescent supply current	I_{CC}	4.0	μA	$V_{IN} = V_{CC}$ or ground, $V_{CC} = 5.5 V$, $T_a = 25^\circ C$
Maximum additional I_{CC} /input (HD74ACT112)	I_{CCT}	1.5	mA	$V_{IN} = V_{CC} - 2.1 V$, $V_{CC} = 5.5 V$ $T_a = \text{Worst case}$

HD74AC112/HD74ACT112

AC Characteristics: HD74AC112

Item	Symbol	V_{CC} (V)* ¹	$T_a = +25^\circ\text{C}$ $C_L = 50\text{ pF}$			$T_a = -40^\circ\text{C to } +85^\circ\text{C}$ $C_L = 50\text{ pF}$		Unit
			Min	Typ	Max	Min	Max	
Maximum clock frequency	f_{\max}	3.3	125	—	—	100	—	MHz
		5.0	150	—	—	125	—	
Propagation delay \overline{C}_p to Q or \overline{Q}	t_{PLH}	3.3	1.0	11.0	14.0	1.0	15.0	ns
		5.0	1.0	8.5	11.0	1.0	12.0	
Propagation delay \overline{C}_p to Q or \overline{Q}	t_{PHL}	3.3	1.0	11.0	14.0	1.0	15.0	ns
		5.0	1.0	8.5	11.0	1.0	12.0	
Propagation delay \overline{C}_D , \overline{S}_D to Q or \overline{Q}	t_{PLH}	3.3	1.0	9.5	12.5	1.0	13.5	ns
		5.0	1.0	7.0	9.5	1.0	10.5	
Propagation delay \overline{C}_D , \overline{S}_D to Q or \overline{Q}	t_{PHL}	3.3	1.0	11.5	14.5	1.0	15.5	ns
		5.0	1.0	9.0	11.0	1.0	12.5	

Note: 1. Voltage Range 3.3 is $3.3\text{ V} \pm 0.3\text{ V}$
Voltage Range 5.0 is $5.0\text{ V} \pm 0.5\text{ V}$

AC Operating Requirements: HD74AC112

Item	Symbol	V_{CC} (V)* ¹	$T_a = +25^\circ\text{C}$	$T_a = -40^\circ\text{C to } +85^\circ\text{C}$		Unit
			Typ	Guaranteed Minimum $C_L = 50\text{ pF}$		
Setup time J or K to \overline{C}_p	t_{su}	3.3	3.0	5.5	6.0	ns
		5.0	2.0	4.5	4.5	
Hold time \overline{C}_p to J or K	t_h	3.3	-1.5	0.0	0.0	ns
		5.0	-0.5	0.0	0.0	
Pulse width \overline{C}_p or \overline{C}_D or \overline{S}_D	t_w	3.3	2.0	5.5	7.0	ns
		5.0	2.0	4.5	5.0	
Recovery time \overline{C}_D or \overline{S}_D to \overline{C}_p	t_{rec}	3.3	1.5	3.5	3.5	ns
		5.0	1.0	3.0	3.0	

Note: 1. Voltage Range 3.3 is $3.3\text{ V} \pm 0.3\text{ V}$
Voltage Range 5.0 is $5.0\text{ V} \pm 0.5\text{ V}$

AC Characteristics: HD74ACT112

Item	Symbol	V_{CC} (V)*1	Ta = +25°C CL = 50 pF			Ta = -40°C to +85°C CL = 50 pF		Unit
			Min	Typ	Max	Min	Max	
Maximum clock frequency	f_{max}	5.0	100	—	—	80	—	MHz
Propagation delay \overline{C}_p to Q or \overline{Q}	t_{PLH}	5.0	1.0	10.5	13.0	1.0	14.0	ns
Propagation delay \overline{C}_p to Q or \overline{Q}	t_{PHL}	5.0	1.0	10.5	13.0	1.0	14.0	
Propagation delay $\overline{C}_D, \overline{S}_D$ to Q or \overline{Q}	t_{PLH}	5.0	1.0	8.0	10.0	1.0	11.0	
Propagation delay $\overline{C}_D, \overline{S}_D$ to Q or \overline{Q}	t_{PHL}	5.0	1.0	10.5	12.5	1.0	13.5	

Note: 1. Voltage Range 5.0 is 5.0 V \pm 0.5 V

AC Operating Requirements: HD74ACT112

Item	Symbol	V_{CC} (V)*1	Ta = +25°C CL = 50 pF		Ta = -40°C to +85°C CL = 50 pF		Unit
			Typ	Guaranteed Minimum	Guaranteed Minimum	Guaranteed Minimum	
Setup time J or K to \overline{C}_p	t_{su}	5.0	2.5	7.0	8.0	8.0	ns
Hold time \overline{C}_p to J or K	t_h	5.0	0.0	1.5	1.5	1.5	
Pulse width \overline{C}_p or \overline{C}_D or \overline{S}_D	t_w	5.0	4.5	7.0	7.0	8.0	
Recovery time $\overline{C}_D, \overline{S}_D$ to \overline{C}_p	t_{rec}	5.0	-2.5	3.0	3.0	3.0	

Note: 1. Voltage Range 5.0 is 5.0 V \pm 0.5 V

Capacitance

Item	Symbol	Typ	Unit	Condition
Input capacitance	C_{IN}	4.5	pF	$V_{CC} = 5.5$ V
Power dissipation capacitance	C_{PD}	35.0	pF	$V_{CC} = 5.0$ V

Package Dimensions

Unit: mm

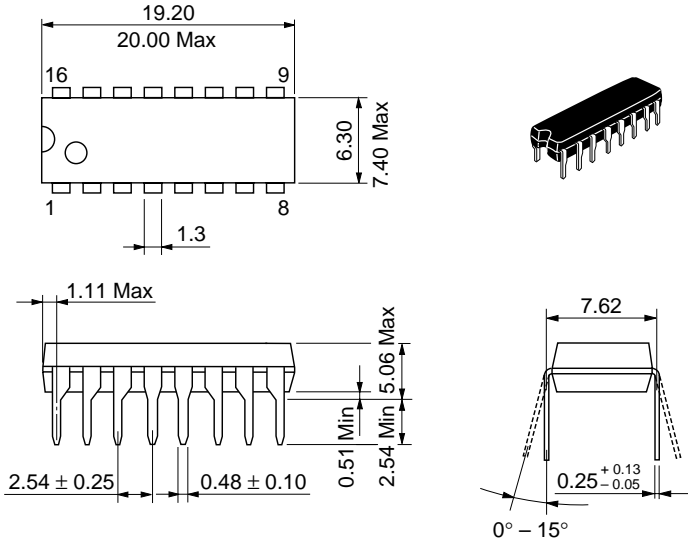

Hitachi Code	DP-16
JEDEC	Conforms
EIAJ	Conforms
Mass (reference value)	1.07 g

Unit: mm

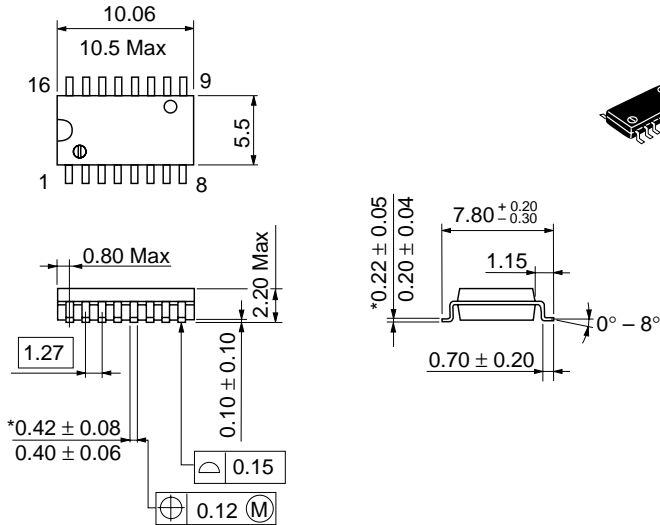

Hitachi Code	FP-16DA
JEDEC	—
EIAJ	Conforms
Mass (reference value)	0.24 g

*Dimension including the plating thickness
Base material dimension

Unit: mm

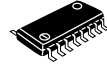
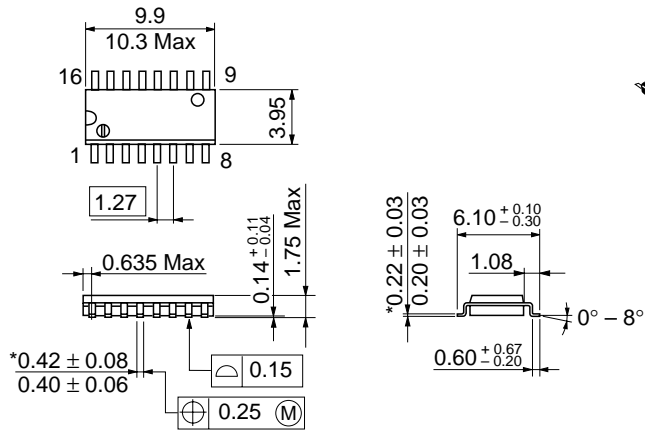

*Dimension including the plating thickness
Base material dimension

Hitachi Code	FP-16DN
JEDEC	Conforms
EIAJ	Conforms
Mass (reference value)	0.15 g

Unit: mm

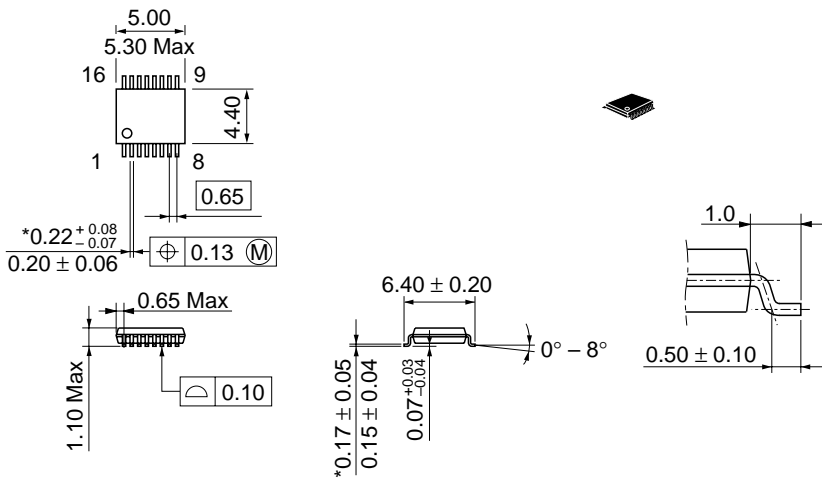

*Dimension including the plating thickness
Base material dimension

Hitachi Code	TTP-16DA
JEDEC	—
EIAJ	—
Mass (reference value)	0.05 g

Cautions

1. Hitachi neither warrants nor grants licenses of any rights of Hitachi's or any third party's patent, copyright, trademark, or other intellectual property rights for information contained in this document. Hitachi bears no responsibility for problems that may arise with third party's rights, including intellectual property rights, in connection with use of the information contained in this document.
2. Products and product specifications may be subject to change without notice. Confirm that you have received the latest product standards or specifications before final design, purchase or use.
3. Hitachi makes every attempt to ensure that its products are of high quality and reliability. However, contact Hitachi's sales office before using the product in an application that demands especially high quality and reliability or where its failure or malfunction may directly threaten human life or cause risk of bodily injury, such as aerospace, aeronautics, nuclear power, combustion control, transportation, traffic, safety equipment or medical equipment for life support.
4. Design your application so that the product is used within the ranges guaranteed by Hitachi particularly for maximum rating, operating supply voltage range, heat radiation characteristics, installation conditions and other characteristics. Hitachi bears no responsibility for failure or damage when used beyond the guaranteed ranges. Even within the guaranteed ranges, consider normally foreseeable failure rates or failure modes in semiconductor devices and employ systemic measures such as fail-safes, so that the equipment incorporating Hitachi product does not cause bodily injury, fire or other consequential damage due to operation of the Hitachi product.
5. This product is not designed to be radiation resistant.
6. No one is permitted to reproduce or duplicate, in any form, the whole or part of this document without written approval from Hitachi.
7. Contact Hitachi's sales office for any questions regarding this document or Hitachi semiconductor products.

HITACHI

Hitachi, Ltd.

Semiconductor & Integrated Circuits.
Nippon Bldg., 2-6-2, Ohte-machi, Chiyoda-ku, Tokyo 100-0004, Japan
Tel: Tokyo (03) 3270-2111 Fax: (03) 3270-5109

URL North America : <http://semiconductor.hitachi.com/>
 Europe : <http://www.hitachi-eu.com/hel/ecg>
 Asia : <http://sicapac.hitachi-asia.com>
 Japan : <http://www.hitachi.co.jp/Sicd/indx.htm>

For further information write to:

Hitachi Semiconductor
(America) Inc.
179 East Tasman Drive,
San Jose, CA 95134
Tel: <1> (408) 433-1990
Fax: <1> (408) 433-0223

Hitachi Europe GmbH
Electronic Components Group
Dornacher StraÙe 3
D-85622 Feldkirchen, Munich
Germany
Tel: <49> (89) 9 9180-0
Fax: <49> (89) 9 29 30 00

Hitachi Europe Ltd.
Electronic Components Group.
Whitebrook Park
Lower Cookham Road
Maidenhead
Berkshire SL6 8YA, United Kingdom
Tel: <44> (1628) 585000
Fax: <44> (1628) 585160

Hitachi Asia Ltd.
Hitachi Tower
16 Collyer Quay #20-00,
Singapore 049318
Tel: <65>-538-6533/538-8577
Fax : <65>-538-6933/538-3877
URL : <http://www.hitachi.com.sg>

Hitachi Asia Ltd.
(Taipei Branch Office)
4/F, No. 167, Tun Hwa North Road,
Hung-Kuo Building,
Taipei (105), Taiwan
Tel: <886>-(2)-2718-3666
Fax : <886>-(2)-2718-8180
Telex : 23222 HAS-TP
URL : <http://www.hitachi.com.tw>

Hitachi Asia (Hong Kong) Ltd.
Group III (Electronic Components)
7/F., North Tower,
World Finance Centre,
Harbour City, Canton Road
Tsim Sha Tsui, Kowloon,
Hong Kong
Tel : <852>-(2)-735-9218
Fax : <852>-(2)-730-0281
URL : <http://www.hitachi.com.hk>

Copyright © Hitachi, Ltd., 2000. All rights reserved. Printed in Japan.
Colophon 2.0

HITACHI