

4,5 TERMINAL LOW DROP VOLTAGE REGULATOR [Low Quiescent Current-Type]

The KIA78R × × × F/PI Series are Low Dropout Voltage Regulator suitable for various electronic equipments. The Regulator has multi function such as over current protection, overheat protection.

FEATURES

- 1.0A Output Low Drop Voltage Regulator.
- Built in ON/OFF Control Terminal. (Active High)
- Built in Over Current Protection, Over Heat Protection Function.
- Low Quiescent Current (Output OFF mode) : 0.5μA(Typ.)
- Low Standby Current : 800μA(Typ.)

LINE UP

ITEM	OUTPUT VOLTAGE (V)	PACKAGE
KIA78R000F/PI	Adjustable (1.25~15V)	F : DPAK-5 PI : TO-220IS-4
KIA78R015F/PI	1.5	
KIA78R018F/PI	1.8	
KIA78R020F/PI	2.0	
KIA78R025F/PI	2.5	
KIA78R030F/PI	3.0	
KIA78R033F/PI	3.3	
KIA78R050F/PI	5.0	

MAXIMUM RATINGS (Ta=25 °C)

CHARACTERISTIC		SYMBOL	RATING	UNIT
Input Voltage		V _{IN}	16	V
ON/OFF Control Voltage		V _C	16	V
Output Current		I _{OUT}	1	A
Power Dissipation 1 (No heatsink)	F	P _{D1}	1.3	W
	PI		1.5	
Power Dissipation 2 (Without heatsink)	F	P _{D2}	13	W
	PI		15	
Junction Temperature		T _j	150	°C
Operating Temperature		T _{opr}	-20~80	°C
Storage Temperature		T _{stg}	-30~150	°C
Soldering Temperature		T _{sol}	260	°C

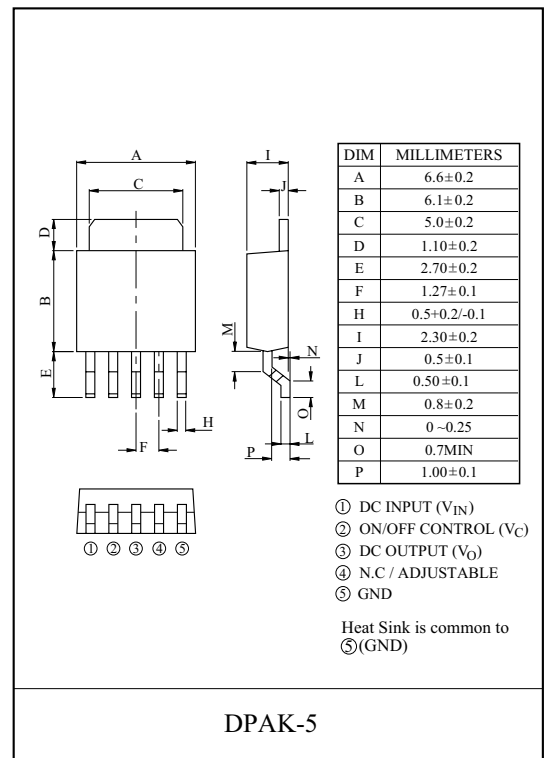
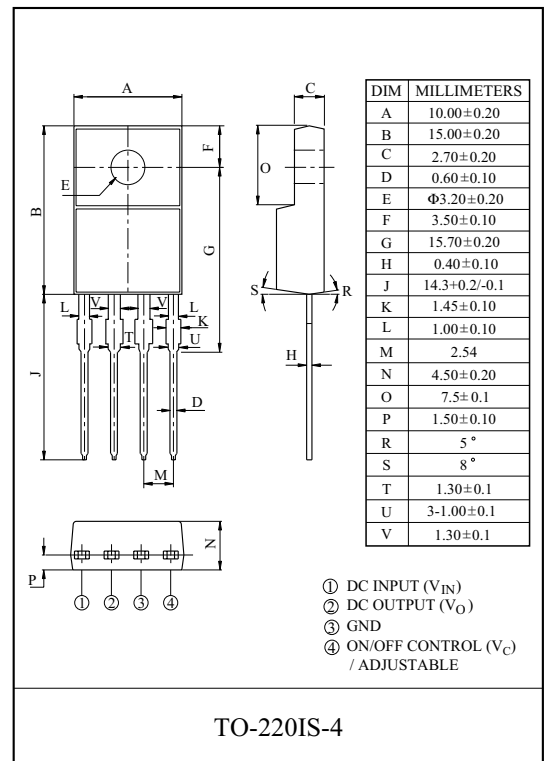

KIA78R000F/PI~KIA78R050F/PI

BLOCK DIAGRAM - 1 (Adjustable-Type)

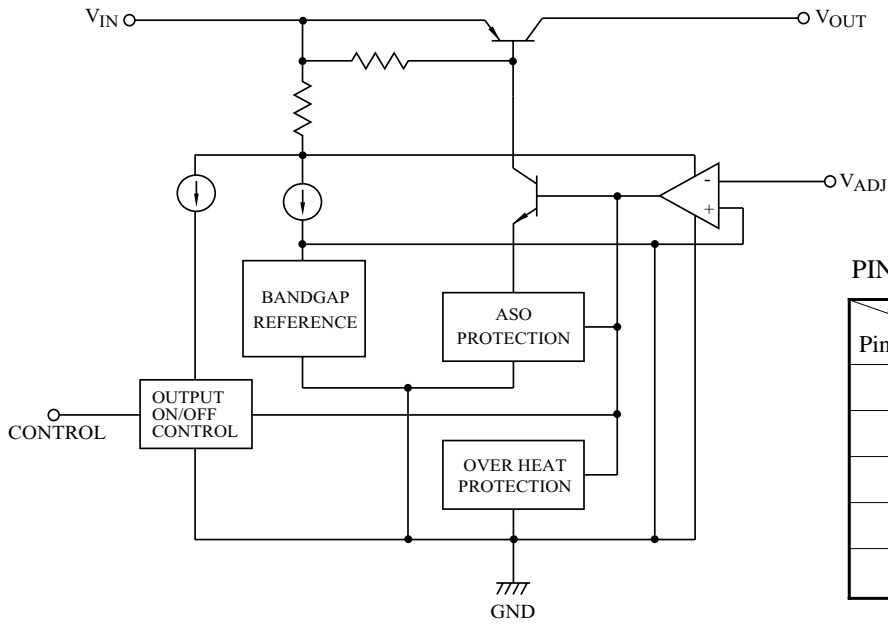

PIN CONNECTION

Pin No.	Item	KIA78R000PI (TO-220IS-4)	KIA78R000F (DPAK-5)
1		V_{IN}	V_{IN}
2		V_{OUT}	V_C
3		GND	V_{OUT}
4		Adj	Adj
5		-	GND

BLOCK DIAGRAM - 2 (Fixed-Type)

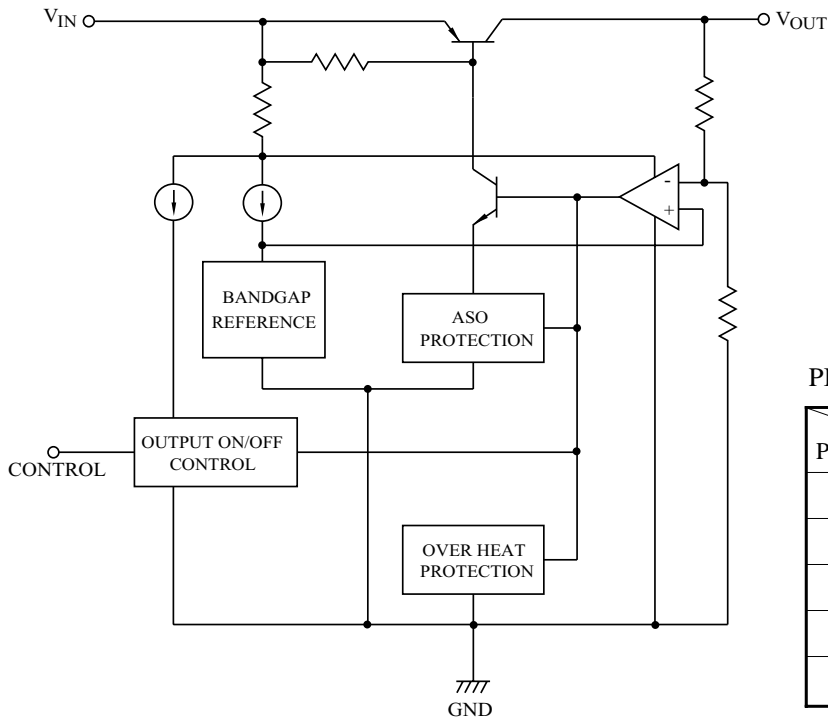

PIN CONNECTION

Pin No.	Item	KIA78R***PI (TO-220IS-4)	KIA78R***F (DPAK-5)
1		V_{IN}	V_{IN}
2		V_{OUT}	V_C
3		GND	V_{OUT}
4		V_C	N.C
5		-	GND

KIA78R000F/PI~KIA78R050F/PI

ELECTRICAL CHARACTERISTICS

KIA78R000F/PI (Unless otherwise specified, $V_{IN}=2.8V$, $T_j=25\text{ }^\circ\text{C}$)

CHARACTERISTIC	SYMBOL	CONDITIONS	MIN.	TYP.	MAX.	UNIT
Input Voltage	V_{IN}	-	2.3	-	15	V
Output Voltage	V_{OUT}	$V_{IN}=2.8V$, $I_{OUT}=0.5A$	1.225	1.25	1.275	V
		$2.8V \leq V_{IN} \leq 12V$, $5mA \leq I_{OUT} \leq 1A$, $0\text{ }^\circ\text{C} \leq T_j \leq 125\text{ }^\circ\text{C}$	1.21	1.25	1.29	
Line Regulation	Reg Line	$2.8V \leq V_{IN} \leq 12V$, $I_{OUT}=0.5A$	-	5	20	mV
Load Regulation	Reg Load	$V_{IN}=2.8V$, $5mA \leq I_{OUT} \leq 1A$,	-	5	20	mV
Quiescent Current	I_B	$2.8V \leq V_{IN} \leq 12V$, $I_{OUT}=0A$	-	0.8	1.8	mA
		$2.8V \leq V_{IN} \leq 12V$, $I_{OUT}=1A$	-	10	20	
Starting Quiescent Current	I_{Bstart}	$V_{IN}=2.1V$, $I_{OUT}=0A$	-	0.7	5	mA
		$V_{IN}=2.5V$, $I_{OUT}=1A$	-	10	30	
Output Noise Voltage	V_{NO}	$V_{IN}=2.8V$, $I_{OUT}=50mA$, $10Hz \leq f \leq 100kHz$	-	110	-	μV_{rms}
Ripple Rejection	$R \cdot R$	$2.8V \leq V_{IN} \leq 12V$, $I_{OUT}=50mA$, $f=120Hz$	53	65	-	dB
Dropout Voltage	V_D	$I_{OUT}=0.5A$	-	0.3	0.5	V
		$I_{OUT}=1A$	-	0.5	-	

ELECTRICAL CHARACTERISTICS

KIA78R015F/PI (Unless otherwise specified, $V_{IN}=3.8V$, $T_j=25\text{ }^\circ\text{C}$)

CHARACTERISTIC	SYMBOL	TEST CONDITIONS	MIN.	TYP.	MAX.	UNIT
Output Voltage	V_{OUT}	$V_{IN}=3.8V$, $I_{OUT}=0.5A$	1.45	1.5	1.55	V
		$2.8V \leq V_{IN} \leq 12V$, $5mA \leq I_{OUT} \leq 1A$, $0\text{ }^\circ\text{C} \leq T_j \leq 125\text{ }^\circ\text{C}$	1.434	1.5	1.566	
Line Regulation	Reg Line	$2.8V \leq V_{IN} \leq 12V$, $I_{OUT}=0.5A$	-	5	20	mV
Load Regulation	Reg Load	$V_{IN}=3.8V$, $5mA \leq I_{OUT} \leq 1A$	-	5	20	mV
Quiescent Current	I_B	$2.8V \leq V_{IN} \leq 12V$, $I_{OUT}=0A$	-	0.8	1.8	mA
		$2.8V \leq V_{IN} \leq 12V$, $I_{OUT}=1A$	-	10	20	
Starting Quiescent Current	I_{Bstart}	$V_{IN}=2.1V$, $I_{OUT}=0A$	-	0.7	5	mA
		$V_{IN}=2.5V$, $I_{OUT}=1A$	-	10	30	
Output Noise Voltage	V_{NO}	$V_{IN}=3.8V$, $I_{OUT}=50mA$, $10Hz \leq f \leq 100kHz$	-	75	-	μV_{rms}
Ripple Rejection	$R \cdot R$	$2.8V \leq V_{IN} \leq 12V$, $I_{OUT}=50mA$, $f=120Hz$	53	65	-	dB
Dropout Voltage	V_D	$I_{OUT}=0.5A$	-	0.5	0.7	V
		$I_{OUT}=1A$	-	0.6	-	
Quiescent Current (OFF mode)	$I_{Q(OFF)}$	$V_C=0.4V$, $2.8V \leq V_{IN} \leq 12V$	-	0.5	5	μA
Output Control Voltage (ON)	$V_{C(ON)}$	$I_{OUT}=0.1A$	2	-	-	V
Output Control Voltage (OFF)	$V_{C(OFF)}$	-	-	-	0.8	V
Output Control Current (ON)	$I_{C(ON)}$	$V_{IN}=V_C=3.8V$, $I_{OUT}=0.1A$	-	20	100	μA
Output Control Current (OFF)	$I_{C(OFF)}$	$V_{IN}=3.8V$, $V_C=0V$	-	0.1	2	μA

KIA78R000F/PI~KIA78R050F/PI

ELECTRICAL CHARACTERISTICS

KIA78R018F/PI (Unless otherwise specified, $V_{IN}=3.8V$, $T_j=25^\circ C$)

CHARACTERISTIC	SYMBOL	TEST CONDITIONS	MIN.	TYP.	MAX.	UNIT
Output Voltage	V_{OUT}	$V_{IN}=3.8V$, $I_{OUT}=0.5A$	1.75	1.8	1.85	V
		$2.8V \leq V_{IN} \leq 12V$, $5mA \leq I_{OUT} \leq 1A$, $0^\circ C \leq T_j \leq 125^\circ C$	1.732	1.8	1.868	
Line Regulation	Reg Line	$2.8V \leq V_{IN} \leq 12V$, $I_{OUT}=0.5A$	-	5	20	mV
Load Regulation	Reg Load	$V_{IN}=3.8V$, $5mA \leq I_{OUT} \leq 1A$	-	5	20	mV
Quiescent Current	I_Q	$2.8V \leq V_{IN} \leq 12V$, $I_{OUT}=0A$	-	0.8	1.8	mA
		$2.8V \leq V_{IN} \leq 12V$, $I_{OUT}=1A$	-	10	20	
Starting Quiescent Current	$I_{Q(start)}$	$V_{IN}=2.1V$, $I_{OUT}=0A$	-	0.7	5	mA
		$V_{IN}=2.5V$, $I_{OUT}=1A$	-	10	30	
Output Noise Voltage	V_{NO}	$V_{IN}=3.8V$, $I_{OUT}=50mA$, $10Hz \leq f \leq 100kHz$	-	75	-	μV_{rms}
Ripple Rejection	$R \cdot R$	$2.8V \leq V_{IN} \leq 12V$, $I_{OUT}=50mA$, $f=120Hz$	53	65	-	dB
Dropout Voltage	V_D	$I_{OUT}=0.5A$	-	0.3	0.5	V
		$I_{OUT}=1A$	-	0.5	-	
Quiescent Current (OFF mode)	$I_{Q(OFF)}$	$V_C=0.4V$, $2.8V \leq V_{IN} \leq 12V$	-	0.5	5	μA
Output Control Voltage (ON)	$V_{C(ON)}$	$I_{OUT}=0.1A$	2	-	-	V
Output Control Voltage (OFF)	$V_{C(OFF)}$	-	-	-	0.8	V
Output Control Current (ON)	$I_{C(ON)}$	$V_{IN}=V_C=3.8V$, $I_{OUT}=0.1A$	-	20	100	μA
Output Control Current (OFF)	$I_{C(OFF)}$	$V_{IN}=3.8V$, $V_C=0V$	-	0.1	2	μA

ELECTRICAL CHARACTERISTICS

KIA78R020F/PI (Unless otherwise specified, $V_{IN}=4V$, $T_j=25^\circ C$)

CHARACTERISTIC	SYMBOL	TEST CONDITIONS	MIN.	TYP.	MAX.	UNIT
Output Voltage	V_{OUT}	$V_{IN}=4V$, $I_{OUT}=0.5A$	1.95	2.0	2.05	V
		$3.0V \leq V_{IN} \leq 12V$, $5mA \leq I_{OUT} \leq 1A$, $0^\circ C \leq T_j \leq 125^\circ C$	1.93	2.0	2.07	
Line Regulation	Reg Line	$3.0V \leq V_{IN} \leq 12V$, $I_{OUT}=0.5A$	-	5	20	mV
Load Regulation	Reg Load	$V_{IN}=4V$, $5mA \leq I_{OUT} \leq 1A$	-	5	20	mV
Quiescent Current	I_Q	$3.0V \leq V_{IN} \leq 12V$, $I_{OUT}=0A$	-	0.8	1.8	mA
		$3.0V \leq V_{IN} \leq 12V$, $I_{OUT}=1A$	-	10	20	
Starting Quiescent Current	$I_{Q(start)}$	$V_{IN}=2.1V$, $I_{OUT}=0A$	-	0.7	5	mA
		$V_{IN}=2.6V$, $I_{OUT}=1A$	-	10	30	
Output Noise Voltage	V_{NO}	$V_{IN}=4V$, $I_{OUT}=50mA$, $10Hz \leq f \leq 100kHz$	-	80	-	μV_{rms}
Ripple Rejection	$R \cdot R$	$3.0V \leq V_{IN} \leq 12V$, $I_{OUT}=50mA$, $f=120Hz$	52	65	-	dB
Dropout Voltage	V_D	$I_{OUT}=0.5A$	-	0.3	0.5	V
		$I_{OUT}=1A$	-	0.5	-	
Quiescent Current (OFF mode)	$I_{Q(OFF)}$	$V_C=0.4V$, $3.0V \leq V_{IN} \leq 12V$	-	0.5	5	μA
Output Control Voltage (ON)	$V_{C(ON)}$	$I_{OUT}=0.1A$	2	-	-	V
Output Control Voltage (OFF)	$V_{C(OFF)}$	-	-	-	0.8	V
Output Control Current (ON)	$I_{C(ON)}$	$V_{IN}=V_C=4V$, $I_{OUT}=0.1A$	-	25	100	μA
Output Control Current (OFF)	$I_{C(OFF)}$	$V_{IN}=4V$, $V_C=0V$	-	0.1	2	μA

KIA78R000F/PI~KIA78R050F/PI

ELECTRICAL CHARACTERISTICS

KIA78R025F/PI (Unless otherwise specified, $V_{IN}=4.5V$, $T_j=25^\circ C$)

CHARACTERISTIC	SYMBOL	TEST CONDITIONS	MIN.	TYP.	MAX.	UNIT
Output Voltage	V_{OUT}	$V_{IN}=4.5V$, $I_{OUT}=0.5A$	2.438	2.5	2.562	V
		$3.5V \leq V_{IN} \leq 12V$, $5mA \leq I_{OUT} \leq 1A$, $0^\circ C \leq T_j \leq 125^\circ C$	2.412	2.5	2.588	
Line Regulation	Reg Line	$3.5V \leq V_{IN} \leq 12V$, $I_{OUT}=0.5A$	-	5	20	mV
Load Regulation	Reg Load	$V_{IN}=4.5V$, $5mA \leq I_{OUT} \leq 1A$	-	5	20	mV
Quiescent Current	I_Q	$3.5V \leq V_{IN} \leq 12V$, $I_{OUT}=0A$	-	0.8	1.8	mA
		$3.5V \leq V_{IN} \leq 12V$, $I_{OUT}=1A$	-	10	20	
Starting Quiescent Current	$I_{Q(start)}$	$V_{IN}=2.1V$, $I_{OUT}=0A$	-	0.9	5	mA
		$V_{IN}=2.7V$, $I_{OUT}=1A$	-	12	30	
Output Noise Voltage	V_{NO}	$V_{IN}=4.5V$, $I_{OUT}=50mA$, $10Hz \leq f \leq 100kHz$	-	95	-	μV_{rms}
Ripple Rejection	$R \cdot R$	$3.5V \leq V_{IN} \leq 12V$, $I_{OUT}=50mA$, $f=120Hz$	53	64	-	dB
Dropout Voltage	V_D	$I_{OUT}=0.5A$	-	0.3	0.5	V
		$I_{OUT}=1A$	-	0.5	-	
Quiescent Current (OFF mode)	$I_{Q(OFF)}$	$V_C=0.4V$, $3.5V \leq V_{IN} \leq 12V$	-	0.5	5	μA
Output Control Voltage (ON)	$V_{C(ON)}$	$I_{OUT}=0.1A$	2	-	-	V
Output Control Voltage (OFF)	$V_{C(OFF)}$	-	-	-	0.8	V
Output Control Current (ON)	$I_{C(ON)}$	$V_{IN}=V_C=4.5V$, $I_{OUT}=0.1A$	-	30	100	μA
Output Control Current (OFF)	$I_{C(OFF)}$	$V_{IN}=4.5V$, $V_C=0V$	-	0.1	2	μA

ELECTRICAL CHARACTERISTICS

KIA78R030F/PI (Unless otherwise specified, $V_{IN}=5V$, $T_j=25^\circ C$)

CHARACTERISTIC	SYMBOL	TEST CONDITIONS	MIN.	TYP.	MAX.	UNIT
Output Voltage	V_{OUT}	$V_{IN}=5.0V$, $I_{OUT}=0.5A$	2.925	3.0	3.075	V
		$4.0V \leq V_{IN} \leq 12V$, $5mA \leq I_{OUT} \leq 1A$, $0^\circ C \leq T_j \leq 125^\circ C$	2.895	3.0	3.105	
Line Regulation	Reg Line	$4.0V \leq V_{IN} \leq 12V$, $I_{OUT}=0.5A$	-	5	20	mV
Load Regulation	Reg Load	$V_{IN}=5.0V$, $5mA \leq I_{OUT} \leq 1A$	-	5	20	mV
Quiescent Current	I_Q	$4.0V \leq V_{IN} \leq 12V$, $I_{OUT}=0A$	-	0.8	1.8	mA
		$4.0V \leq V_{IN} \leq 12V$, $I_{OUT}=1A$	-	10	20	
Starting Quiescent Current	$I_{Q(start)}$	$V_{IN}=2.1V$, $I_{OUT}=0A$	-	1.1	5	mA
		$V_{IN}=2.8V$, $I_{OUT}=1A$	-	13	30	
Output Noise Voltage	V_{NO}	$V_{IN}=5.0V$, $I_{OUT}=50mA$, $10Hz \leq f \leq 100kHz$	-	110	-	μV_{rms}
Ripple Rejection	$R \cdot R$	$4.0V \leq V_{IN} \leq 12V$, $I_{OUT}=50mA$, $f=120Hz$	50	63	-	dB
Dropout Voltage	V_D	$I_{OUT}=0.5A$	-	0.3	0.5	V
		$I_{OUT}=1A$	-	0.5	-	
Quiescent Current (OFF mode)	$I_{Q(OFF)}$	$V_C=0.4V$, $4.0V \leq V_{IN} \leq 12V$	-	0.5	5	μA
Output Control Voltage (ON)	$V_{C(ON)}$	$I_{OUT}=0.1A$	2	-	-	V
Output Control Voltage (OFF)	$V_{C(OFF)}$	-	-	-	0.8	V
Output Control Current (ON)	$I_{C(ON)}$	$V_{IN}=V_C=4.5V$, $I_{OUT}=0.1A$	-	35	100	μA
Output Control Current (OFF)	$I_{C(OFF)}$	$V_{IN}=5.0V$, $V_C=0V$	-	0.1	2	μA

KIA78R000F/PI~KIA78R050F/PI

ELECTRICAL CHARACTERISTICS

KIA78R033F/PI (Unless otherwise specified, $V_{IN}=5.3V$, $T_j=25^\circ C$)

CHARACTERISTIC	SYMBOL	TEST CONDITIONS	MIN.	TYP.	MAX.	UNIT
Output Voltage	V_{OUT}	$V_{IN}=5.3V$, $I_{OUT}=0.5A$	3.218	3.3	3.382	V
		$4.3V \leq V_{IN} \leq 12V$, $5mA \leq I_{OUT} \leq 1A$, $0^\circ C \leq T_j \leq 125^\circ C$	3.184	3.3	3.416	
Line Regulation	Reg Line	$4.3V \leq V_{IN} \leq 12V$, $I_{OUT}=0.5A$	-	5	20	mV
Load Regulation	Reg Load	$V_{IN}=5.3V$, $5mA \leq I_{OUT} \leq 1A$	-	5	20	mV
Quiescent Current	I_Q	$4.3V \leq V_{IN} \leq 12V$, $I_{OUT}=0A$	-	0.8	1.8	mA
		$4.3V \leq V_{IN} \leq 12V$, $I_{OUT}=1A$	-	10	20	
Starting Quiescent Current	$I_{Q(start)}$	$V_{IN}=2.1V$, $I_{OUT}=0A$	-	1.1	5	mA
		$V_{IN}=2.9V$, $I_{OUT}=1A$	-	13	30	
Output Noise Voltage	V_{NO}	$V_{IN}=5.3V$, $I_{OUT}=50mA$, $10Hz \leq f \leq 100kHz$	-	115	-	μV_{rms}
Ripple Rejection	$R \cdot R$	$4.3V \leq V_{IN} \leq 12V$, $I_{OUT}=50mA$, $f=120Hz$	48	61	-	dB
Dropout Voltage	V_D	$I_{OUT}=0.5A$	-	0.3	0.5	V
		$I_{OUT}=1A$	-	0.5	-	
Quiescent Current (OFF mode)	$I_{Q(OFF)}$	$V_C=0.4V$, $4.3V \leq V_{IN} \leq 12V$	-	0.5	5	μA
Output Control Voltage (ON)	$V_{C(ON)}$	$I_{OUT}=0.1A$	2	-	-	V
Output Control Voltage (OFF)	$V_{C(OFF)}$	-	-	-	0.8	V
Output Control Current (ON)	$I_{C(ON)}$	$V_{IN}=V_C=5.3V$, $I_{OUT}=0.1A$	-	35	100	μA
Output Control Current (OFF)	$I_{C(OFF)}$	$V_{IN}=5.3V$, $V_C=0V$	-	0.1	2	μA

ELECTRICAL CHARACTERISTICS

KIA78R050F/PI (Unless otherwise specified, $V_{IN}=7V$, $T_j=25^\circ C$)

CHARACTERISTIC	SYMBOL	TEST CONDITIONS	MIN.	TYP.	MAX.	UNIT
Output Voltage	V_{OUT}	$V_{IN}=7V$, $I_{OUT}=0.5A$	4.88	5.0	5.12	V
		$6.0V \leq V_{IN} \leq 12V$, $5mA \leq I_{OUT} \leq 1A$, $0^\circ C \leq T_j \leq 125^\circ C$	4.83	5.0	5.17	
Line Regulation	Reg Line	$6.0V \leq V_{IN} \leq 12V$, $I_{OUT}=0.5A$	-	5	20	mV
Load Regulation	Reg Load	$V_{IN}=7.0V$, $5mA \leq I_{OUT} \leq 1A$	-	5	20	mV
Quiescent Current	I_Q	$6.0V \leq V_{IN} \leq 12V$, $I_{OUT}=0A$	-	0.8	1.8	mA
		$6.0V \leq V_{IN} \leq 12V$, $I_{OUT}=1A$	-	10	20	
Starting Quiescent Current	$I_{Q(start)}$	$V_{IN}=2.1V$, $I_{OUT}=0A$	-	1.3	5	mA
		$V_{IN}=3.0V$, $I_{OUT}=1A$	-	14	30	
Output Noise Voltage	V_{NO}	$V_{IN}=7.0V$, $I_{OUT}=50mA$, $10Hz \leq f \leq 100kHz$	-	150	-	μV_{rms}
Ripple Rejection	$R \cdot R$	$6.0V \leq V_{IN} \leq 12V$, $I_{OUT}=50mA$, $f=120Hz$	48	60	-	dB
Dropout Voltage	V_D	$I_{OUT}=0.5A$	-	0.3	0.5	V
		$I_{OUT}=1A$	-	0.5	-	
Quiescent Current (OFF mode)	$I_{Q(OFF)}$	$V_C=0.4V$, $6.0V \leq V_{IN} \leq 12V$	-	0.5	5	μA
Output Control Voltage (ON)	$V_{C(ON)}$	$I_{OUT}=0.1A$	2	-	-	V
Output Control Voltage (OFF)	$V_{C(OFF)}$	-	-	-	0.8	V
Output Control Current (ON)	$I_{C(ON)}$	$V_{IN}=V_C=7.0V$, $I_{OUT}=0.1A$	-	50	100	μA
Output Control Current (OFF)	$I_{C(OFF)}$	$V_{IN}=7.0V$, $V_C=0V$	-	0.1	2	μA

KIA78R000F/PI~KIA78R050F/PI

Fig. 1 Standard Test Circuit & Application Circuit (Adjustable-Type)

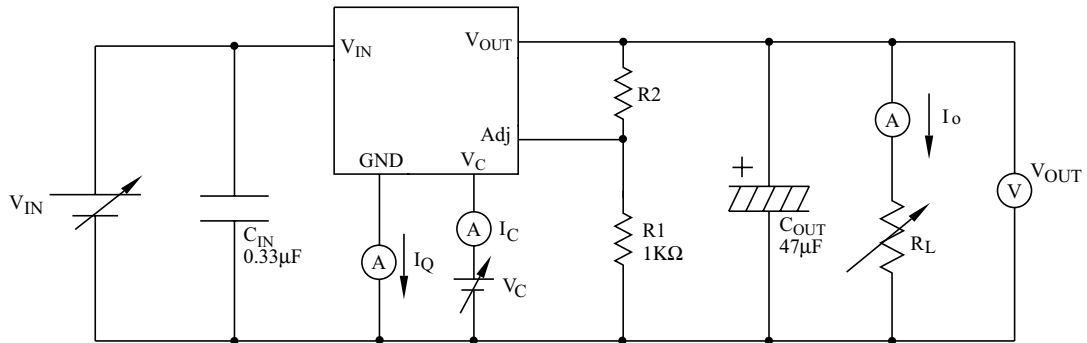

$$V_{OUT} = V_{ref} \times \left(1 + \frac{R2}{R1}\right) = 1.25 \times \left(1 + \frac{R2}{R1}\right)$$

C_{IN} : More than $0.33\mu F$ required if regulator is located an appreciable distance from power supply filter.

You must use to prevent from the parasitic oscillation.

C_{OUT} : More than $47\mu F$. You must use the Low-impedance-type(low ESR) capacitor.

Fig. 2 Standard Test Circuit (Fixed-Type)

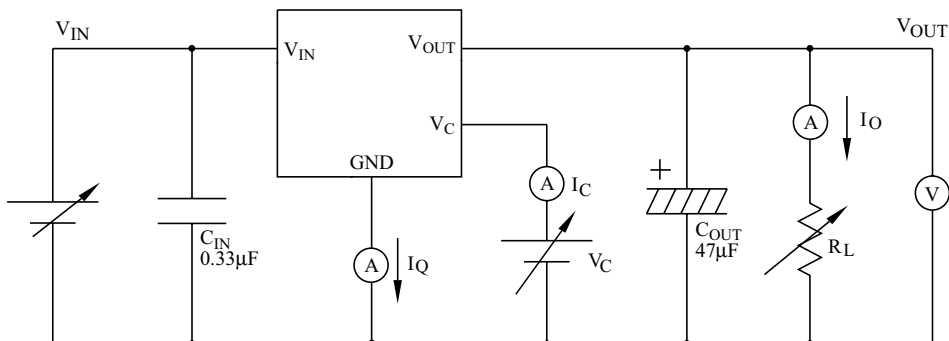

KIA78R000F/PI~KIA78R050F/PI

Fig. 3 Ripple Rejection Test Circuit (Adjustable-Type)

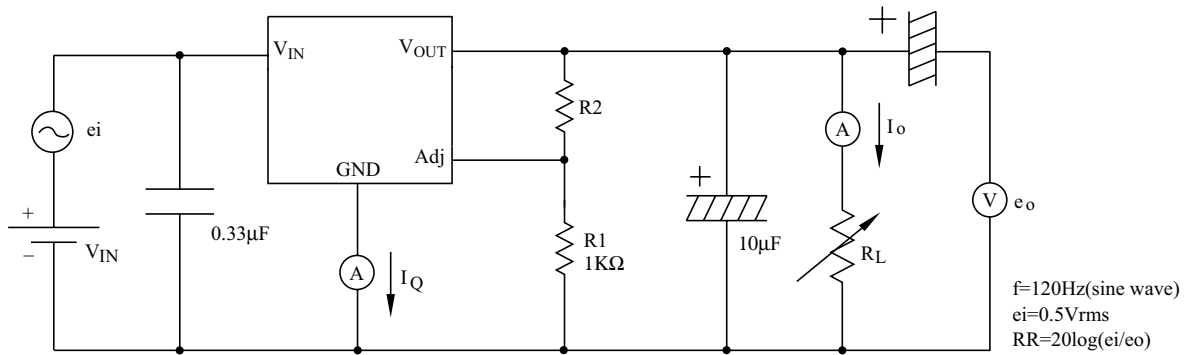

Fig. 4 Ripple Rejection Test Circuit (Fixed-Type)

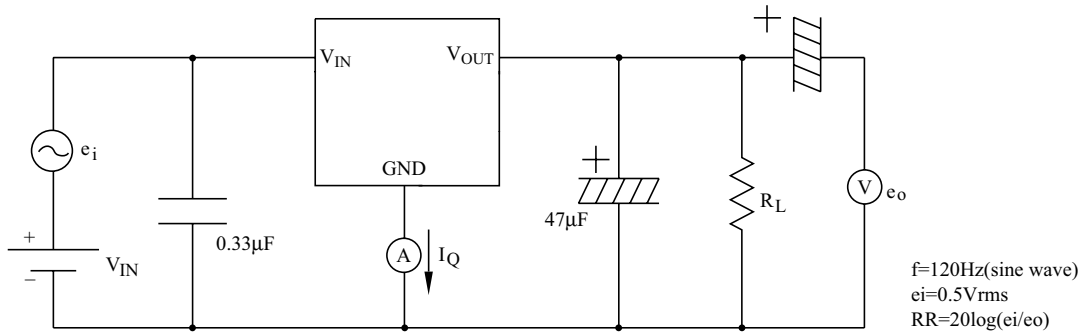
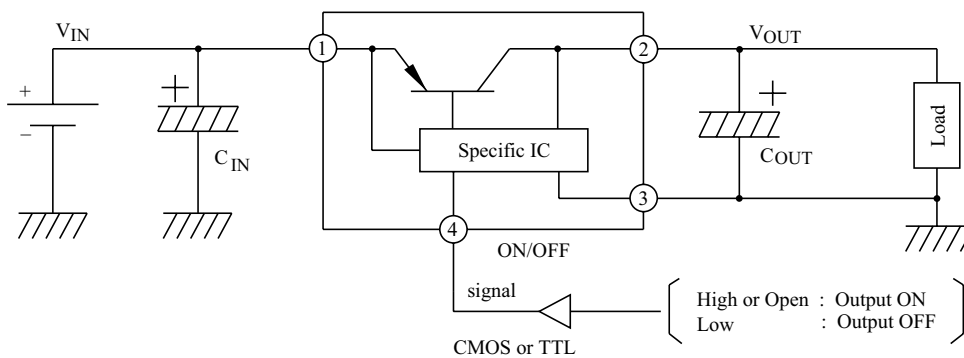

Fig. 5 Application Circuit for Standard (Fixed-Type)



C_{IN} : More than $0.33\mu\text{F}$ required if regulator is located an appreciable distance from power supply filter.

You must use to prevent from the parasitic oscillation.

C_{OUT} : More than $47\mu\text{F}$. You must use the Low-impedance-type(low ESR) capacitor.

KIA78R000F/PI~KIA78R050F/PI

Fig. 6 $V_{OUT} - T_j$

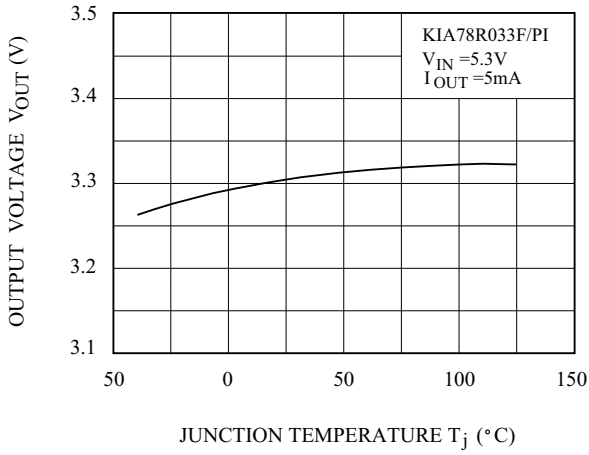

Fig. 7 $V_{OUT} - V_{IN}$

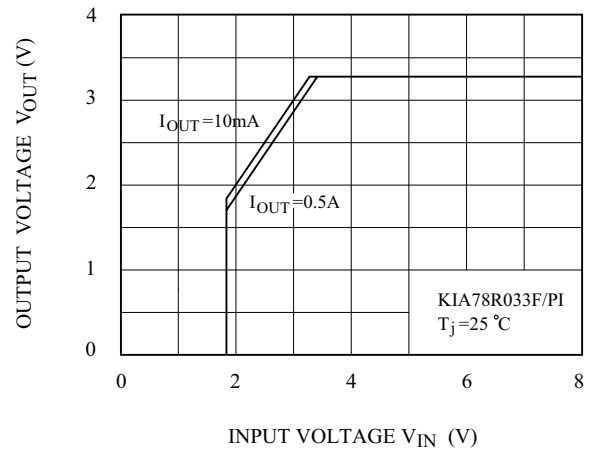

Fig. 8 $I_B - V_{IN}$

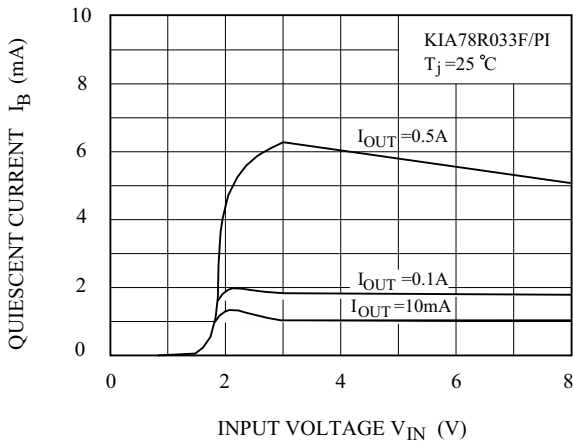

Fig. 9 $I_B - T_j$

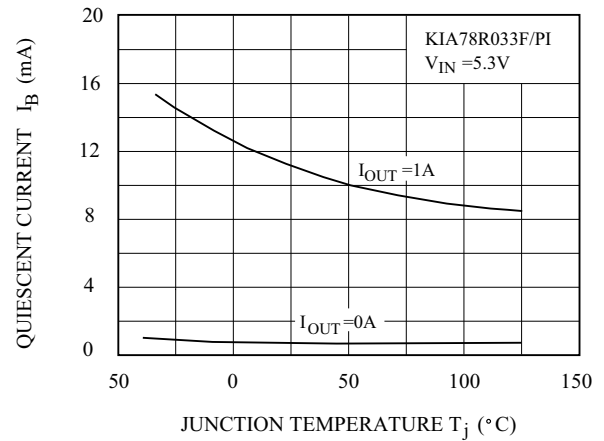

Fig. 10 $I_B - I_{OUT}$

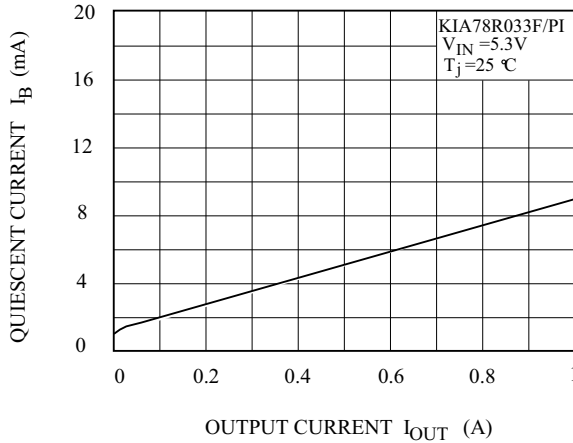
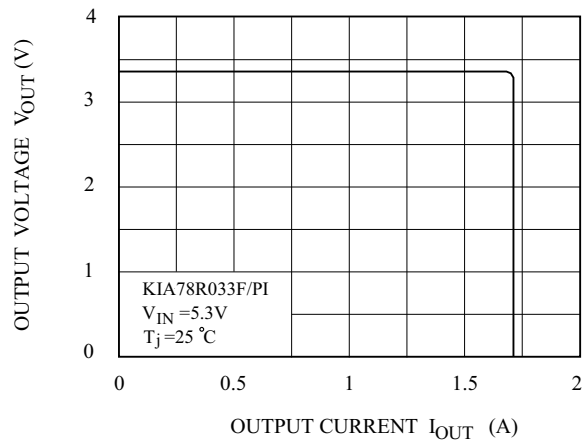

Fig. 11 $V_{OUT} - I_{OUT}$



KIA78R000F/PI~KIA78R050F/PI

Fig.12 $V_D - T_j$

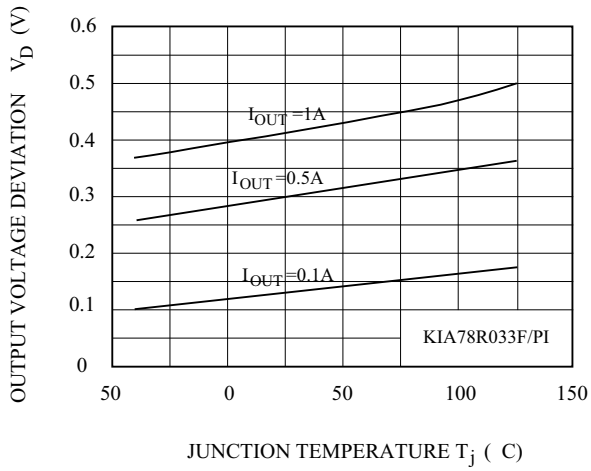

Fig.13 RR-f

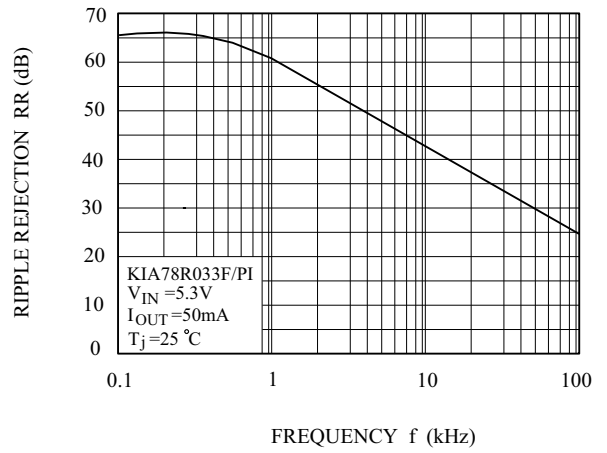

Fig.14 $P_D - T_a$ (F-Type : DPAK-5)

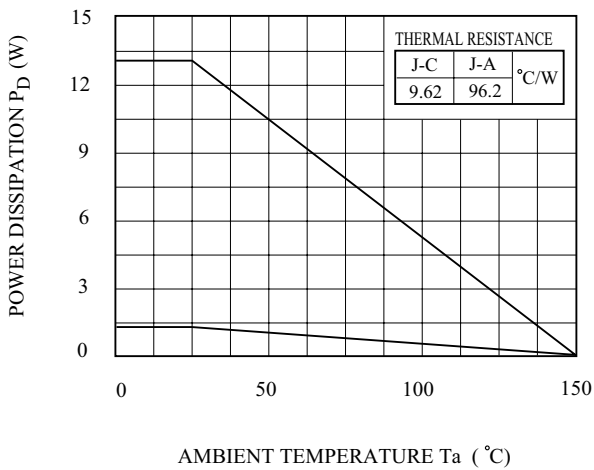

Fig.15 $P_D - T_a$ (PI-Type : TO-220IS-4)

