

OBSOLETE PRODUCT
 See HA-2546
 contact our Technical Support Center at
 1-888-INTERSIL or www.intersil.com/tsc

**100MHz, Two Quadrant,
 Current Output, Analog Multiplier**

The HA-2547 is a monolithic, high speed, two quadrant, analog multiplier constructed in Intersil's Dielectrically Isolated High Frequency Process. The high frequency performance of the HA-2547 rivals the best analog multipliers currently available including hybrids.

The single-ended current output of the HA-2547 has a 100MHz signal bandwidth ($R_L = 50\Omega$) and a 22MHz control input bandwidth. High bandwidth and low distortion make this part an ideal component in video systems. The suitability for precision video applications is demonstrated further by low multiplication error (1.6%), low feedthrough (-50dB), and differential inputs with low bias currents (1.2 μ A). The HA-2547 is also well suited for mixer circuits as well as AGC applications for sonar, radar, and medical imaging equipment.

The current output of the HA-2547 allows it to achieve higher bandwidths than voltage output multipliers. An internal feedback resistor is provided to give an accurate current-to-voltage conversion and is trimmed to give a full scale output voltage of $\pm 5V$. The HA-2547 is not limited to multiplication applications only; frequency doubling and power detection are also possible.

Part Number Information

PART NUMBER	TEMP. RANGE (°C)	PACKAGE	PKG. NO.
HA1-2547-5	0 to 75	16 Ld CERDIP	F16.3
HA1-2547-9	-40 to 85	16 Ld CERDIP	F16.3

Features

- Low Multiplication Error 1.6%
- Input Bias Currents 1.2 μ A
- Signal Input Feedthrough at 5MHz -50dB
- Wide Signal Bandwidth 100MHz
- Wide Control Bandwidth 22MHz

Applications

- Military Avionics
- Missile Guidance Systems
- Medical Imaging Displays
- Video Mixers
- Sonar AGC Processors
- Radar Signal Conditioning
- Voltage Controlled Amplifier
- Vector Generator

Pinout

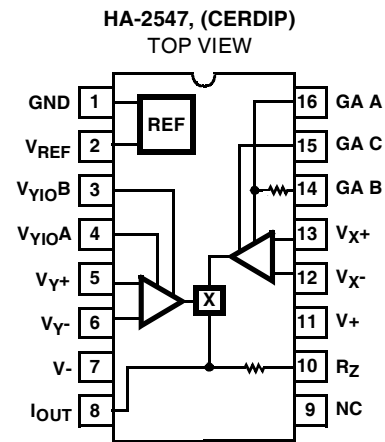

Schematic

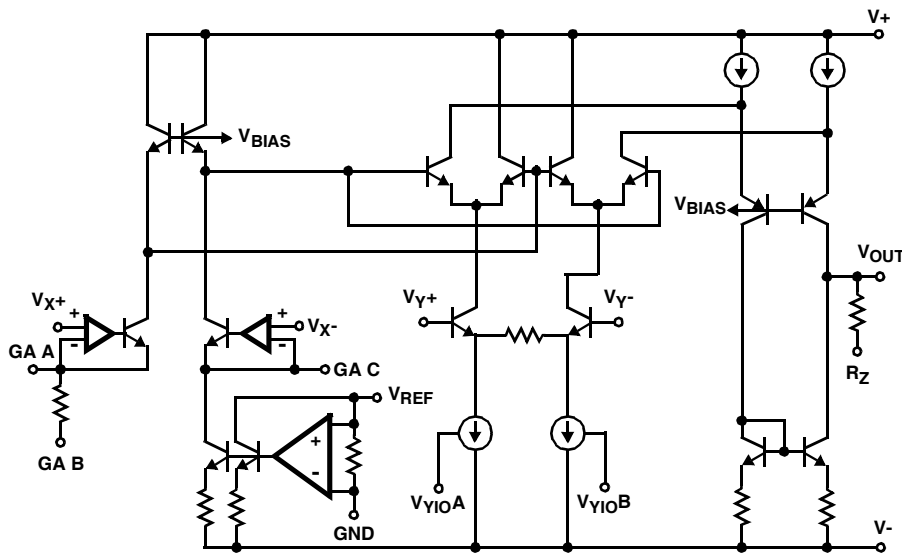

Absolute Maximum Ratings

Voltage Between V+ and V- Terminals 35V
 Differential Input Voltage 6V
 Output Current 3mA

Operating Conditions

Temperature Range
 HA-2547-9 -40°C to 85°C
 HA-2547-5 0°C to 75°C

CAUTION: Stresses above those listed in "Absolute Maximum Ratings" may cause permanent damage to the device. This is a stress only rating and operation of the device at these or any other conditions above those indicated in the operational sections of this specification is not implied.

NOTE:

1. θ_{JA} is measured with the component mounted on an evaluation PC board in free air.

Thermal Information

Thermal Resistance (Typical, Note 1) θ_{JA} (°C/W) θ_{JC} (°C/W)
 CERDIP Package 75 20
 Maximum Junction Temperature 175°C
 Maximum Storage Temperature Range -65°C to 150°C
 Maximum Lead Temperature (Soldering 10s) 300°C

Electrical Specifications $V_{SUPPLY} = \pm 15V$, R_Z (Pin 10) Grounded, Unless Otherwise Specified. Pin 14 Connected to Pin 15 for Scale Factor = 2

PARAMETER	TEST CONDITIONS	TEMP. (°C)	MIN	TYP	MAX	UNITS
MULTIPLIER PERFORMANCE						
Multiplication Error (Note 2)		25	-	1.6	3	%FS
		Full	-	3.0	7	%FS
Multiplication Error Drift		Full	-	0.003	-	%/°C
Scale Factor Error		Full	-	0.7	5	%
THD+N	Note 3	25	-	0.03	-	%
Output Offset Voltage	$V_X = 0V$, $V_Y = 0V$	25	-	6	15	mV
		Full	-	14	20	mV
Average Offset Voltage Drift		Full	-	-	-	$\mu V/°C$
SIGNAL INPUT, V_Y						
Input Offset Voltage		25	-	4	10	mV
		Full	-	8	20	mV
Average Offset Voltage Drift		Full	-	35	-	$\mu V/°C$
Input Bias Current		25	-	7	15	μA
		Full	-	10	15	μA
Input Offset Current		25	-	0.7	2	μA
		Full	-	1.0	3	μA
Input Differential Resistance		25	-	720	-	k Ω
Input Capacitance		25	-	2.5	-	pF
Small Signal Bandwidth (-3dB) (Note 7)	$R_L = 50\Omega$	25	-	100	-	MHz
Feedthrough	Note 10	25	-	-50	-	dB
Differential Input Range		25	± 5	-	-	V
Common Mode Range		25	-	± 9	-	V
CMRR	Note 4	Full	60	78	-	dB
V_Y TRANSIENT RESPONSE						
Rise Time	Note 12	25	-	5	-	ns
Propagation Delay		25	-	3	-	ns

Electrical Specifications $V_{SUPPLY} = \pm 15V$, R_Z (Pin 10) Grounded, Unless Otherwise Specified. Pin 14 Connected to Pin 15 for Scale Factor = 2 **(Continued)**

PARAMETER	TEST CONDITIONS	TEMP. (°C)	MIN	TYP	MAX	UNITS
CONTROL INPUT, V_X						
Input Offset Voltage		25	-	1	2	mV
		Full	-	2	20	mV
Average Offset Voltage Drift		Full	-	12	-	$\mu V/^\circ C$
Input Bias Current		25	-	1.2	2	μA
		Full	-	1.8	5	μA
Input Offset Current		25	-	0.3	2	μA
		Full	-	0.4	3	μA
Input Capacitance		25	-	2.5	-	pF
Input Differential Resistance		25	-	360	-	k Ω
Small Signal Bandwidth (-3dB) (Note 7)	$R_L = 50\Omega$	25	-	22	-	MHz
Feedthrough	Note 11	25	-	-40	-	dB
Input Range (Note 9)		Full	+2	-	-	V
Common Mode Range		25	-	± 9	-	V
CMRR	Note 5	25	-	75	-	dB
V_X TRANSIENT RESPONSE						
Rise Time	Note 13	25	-	15	-	ns
Propagation Delay		25	-	25	-	ns
OUTPUT CHARACTERISTICS						
Full Scale Output Voltage	$V_Y = \pm 5V$, $V_X = 2.5V$	Full	-	± 6.25	-	V
Full Scale Output Current (Note 8)		25	-	2	-	mA
Output Capacitance		25	-	6.5	-	pF
Output Resistance		25	-	4	-	M Ω
POWER SUPPLY						
PSRR	Note 6	Full	58	63	-	dB
I_{CC}		Full	-	20	29	mA

NOTES:

2. Error is percent of full scale, 1% = 50mV.
3. $f = 10kHz$, $V_Y = 1V_{RMS}$, $V_X = 2V$.
4. $V_Y = 0$ to $\pm 5V$, $V_X = 2V$.
5. $V_X = 0$ to $2V$, $V_Y = 5V$.
6. $V_S = \pm 12V$ to $\pm 15V$, $V_Y = 5V$, $V_X = 2V$.
7. Guaranteed by sample test and not 100% tested.
8. Output current tolerance is $\pm 20\%$.
9. Scale Factor = 2. See Applications Information.
10. $f = 5MHz$, $V_X = 0$, $V_Y = 200mV_{RMS}$. Relative to full scale output.
11. $f = 5MHz$, $V_Y = 0$, $V_{X+} = 200mV_{RMS}$, $V_{X-} = -0.5V$. Relative to full scale output.
12. $V_Y = \pm 5V$, $V_X = 2V$, $R_L = 50\Omega$.
13. $V_X = 0$ to $2V$, $V_Y = 5V$, $R_L = 50\Omega$.

Test Circuits and Waveforms

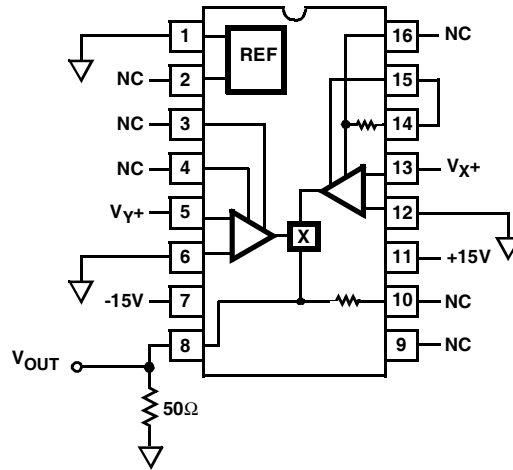
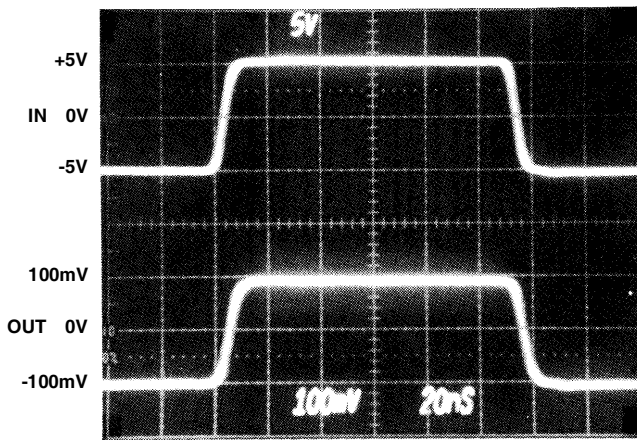
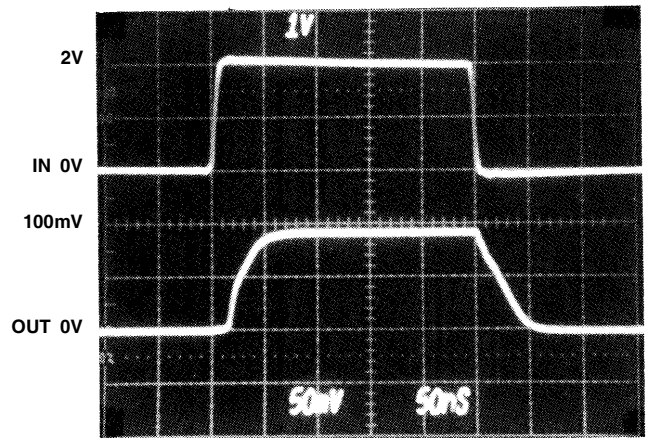

FIGURE 1. AC AND TRANSIENT RESPONSE TEST CIRCUIT



Horizontal Scale: 20ns/Div.

V_Y TRANSIENT RESPONSE



Horizontal Scale: 50ns/Div.

V_X TRANSIENT RESPONSE

Application Information

Theory of Operation

The HA-2547 is a current output, two quadrant multiplier with one differential signal channel, V_{Y+} and V_{Y-} , and one differential control channel, V_{X+} and V_{X-} . Figure 2 shows a detailed functional block diagram of the HA-2547. The differential voltages of channels V_X and V_Y are converted to differential currents. These differential currents are then multiplied in a circuit similar to a Gilbert Cell multiplier, producing a differential current product. The differential product currents are then converted to a single-ended output current which is typically 2mA, $\pm 20\%$ at full scale ($V_X = 2V$, $V_Y = \pm 5V$). A trimmed internal scaling resistor, R_Z , is designed to convert the output current to an accurate voltage by grounding R_Z (pin 10). R_Z is trimmed such that at full scale output current the voltage drop across R_Z will be $\pm 5.0V$.

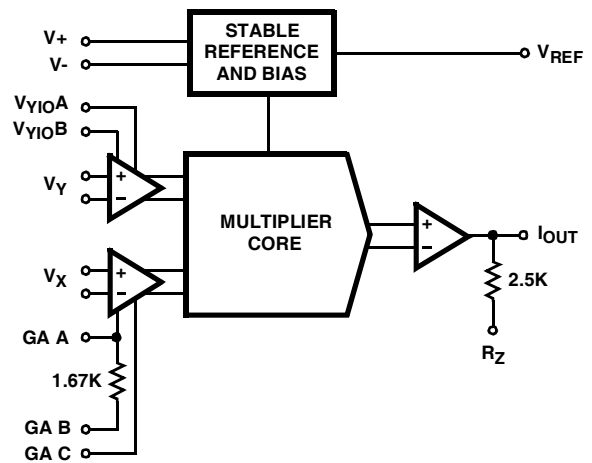

FIGURE 2.

The transfer equation for the HA-2547 is:

$$I_{OUT} = \frac{V_{OUT}}{R_Z} = \frac{(V_{X+} - V_{X-})(V_{Y+} - V_{Y-})}{SF \times R_Z}, \text{ where}$$

SF = Scale Factor

$R_Z = 2.5k\Omega$ (Internal)

V_X, V_Y = Differential Inputs

The scale factor is used to maintain the output of the multiplier within the normal operating range of $\pm 5V$. The scale factor can be defined by the user by way of an optional external resistor, R_{EXT} , and the Gain Adjust pins: Gain Adjust A (GA A), Gain Adjust B (GA B), and Gain Adjust C (GA C). The scale factor is determined as follows:

SF = 2, when GA B is shorted to GA C

$SF \approx (1.2)(R_{EXT})$, when R_{EXT} is connected between GA A and GA C (R_{EXT} is in $k\Omega$)

$SF \approx (1.2)(R_{EXT} + 1.667k\Omega)$, when R_{EXT} is connected to GA B and GA C (R_{EXT} is in $k\Omega$).

The scale factor can be adjusted from 2 to 5. It should be noted that any adjustments to the scale factor will affect the AC performance of the control channel, V_X . The normal input operating range of V_X is equal to the scale factor value.

A typical multiplier configuration is shown in Figure 3. The ideal transfer function for this configuration is shown below, illustrating two quadrant operation:

$$V_{OUT} = \frac{(V_{X+} - V_{X-})(V_{Y+} - V_{Y-})}{2},$$

when $(V_{X+} - V_{X-}) \geq 0$

$$V_{OUT} = 0, \text{ when } (V_{X+} - V_{X-}) < 0$$

The V_{X-} pin is usually connected to ground so that when V_{X+} is negative there is no signal at the output, i.e. two quadrant operation. If the V_X input is a negative going signal the V_{X+} pin maybe grounded and the V_{X-} pin used as the input. The V_{Y-} terminal is usually grounded allowing V_{Y+} to swing $\pm 5V$. R_Z is normally used as a feedback resistor for an external op amp to provide an accurate current-to-voltage conversion. The scale factor is normally set to 2 by connecting GA B to GA C. Therefore, the transfer function becomes:

$$V_{OUT} = \frac{(V_{X+})(V_{Y+})}{2}$$

The multiplication error is trimmed to be minimum at full scale, $V_X = 2V$ and $V_Y = \pm 5V$. When $V_Y = \pm 5V$, the worst case multiplication error occurs when $V_X \approx 0.8V$ (Refer to typical performance curves).

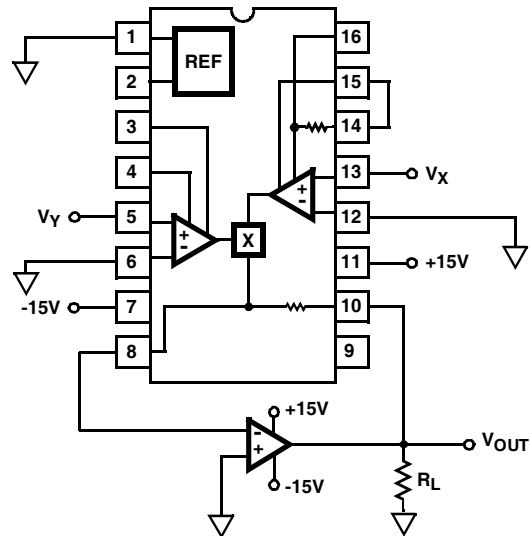

FIGURE 3.

Operation At Various Supply Voltages

The HA-2547 will operate over a range of supply voltages, $\pm 8V$ to $\pm 15V$. Use of supply voltages below $\pm 12V$ will cause degradation of electrical parameters.

Offset Adjustment

The signal channel offset voltage may be nulled by using a 20K potentiometer between V_{Y10} Adjust pins A and B and connecting the wiper to V_- . Reducing the signal channel offset voltage will reduce V_X AC feedthrough and improve the multiplication error.

Typical Performance Curves $V_S = \pm 15V, T_A = 25^\circ C$

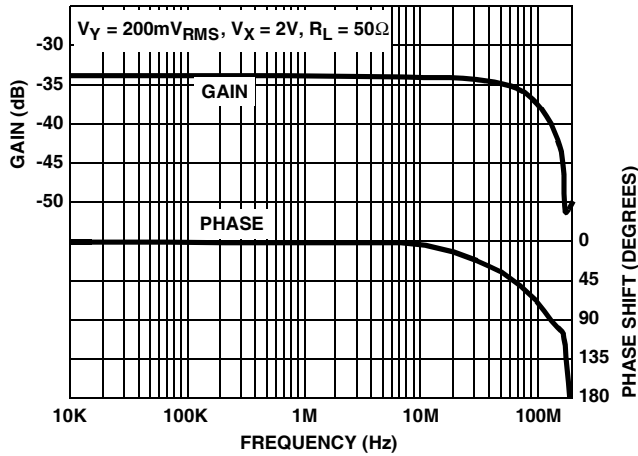

FIGURE 4. V_Y vs FREQUENCY

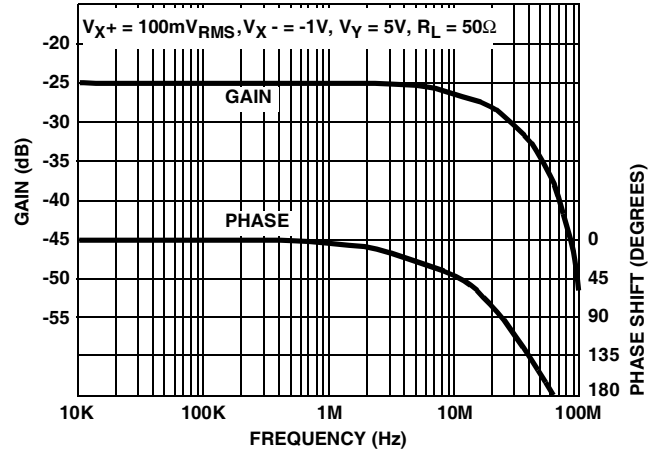

FIGURE 5. V_X vs FREQUENCY

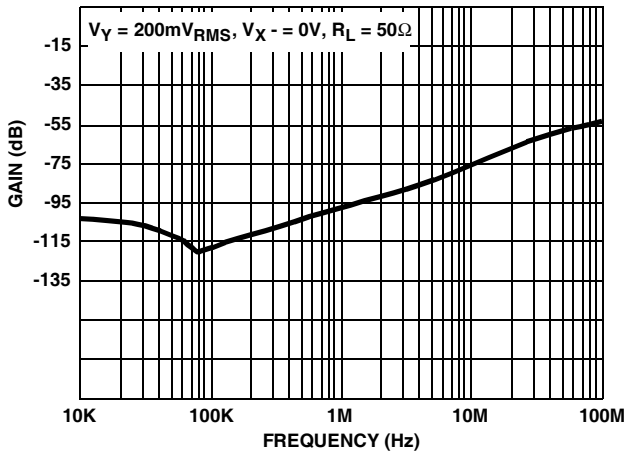

FIGURE 6. V_Y FEEDTHROUGH vs FREQUENCY

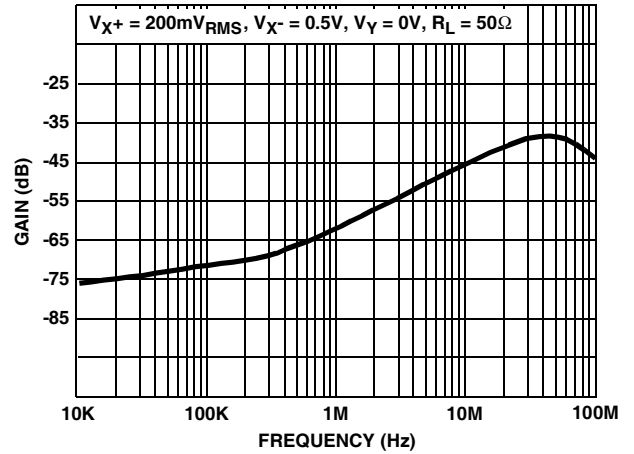

FIGURE 7. V_X FEEDTHROUGH vs FREQUENCY

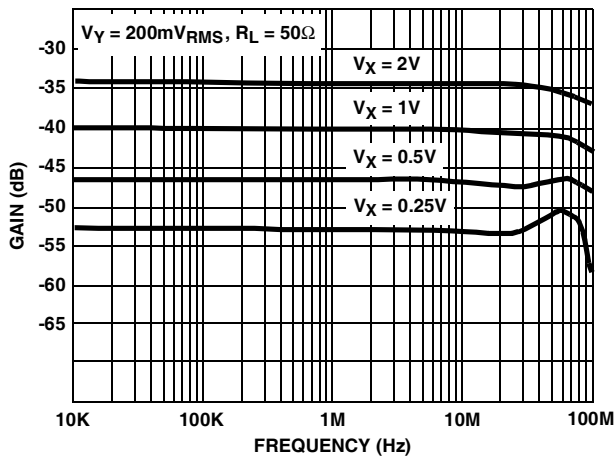

FIGURE 8. VARIOUS V_Y FREQUENCY RESPONSES

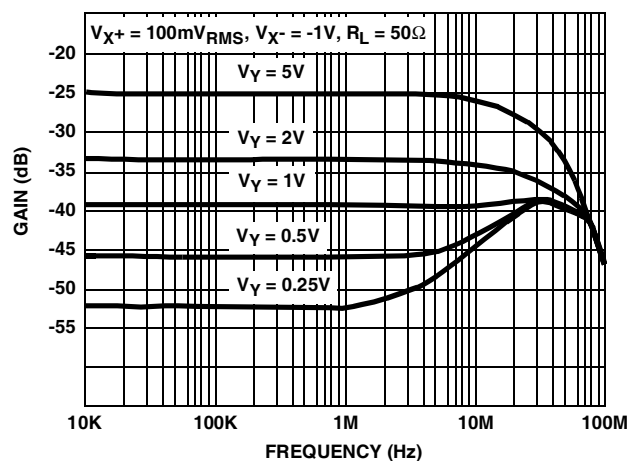

FIGURE 9. VARIOUS V_X FREQUENCY RESPONSES

Typical Performance Curves $V_S = \pm 15V, T_A = 25^\circ C$ (Continued)

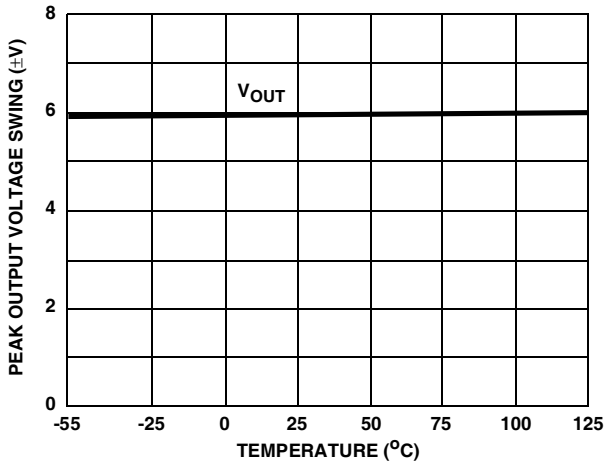

FIGURE 10. OUTPUT VOLTAGE SWING vs TEMPERATURE

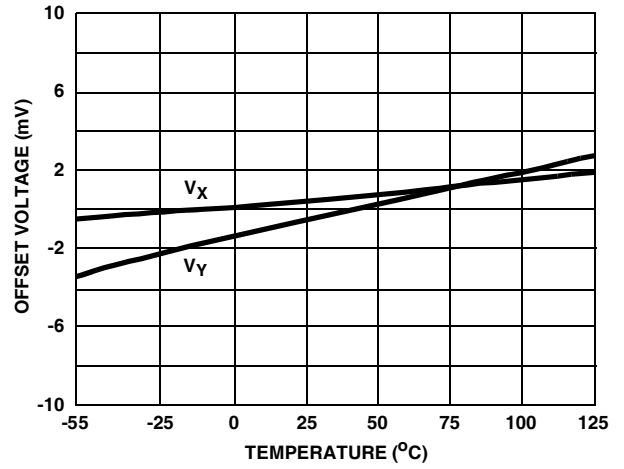

FIGURE 11. OFFSET VOLTAGE vs TEMPERATURE

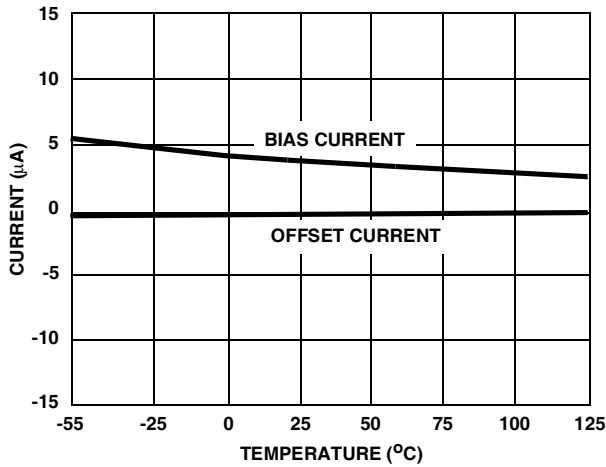

FIGURE 12. V_Y OFFSET/BIAS CURRENT vs TEMPERATURE

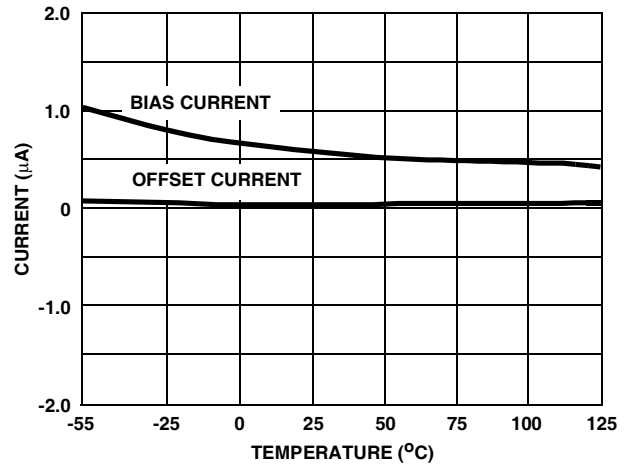

FIGURE 13. V_X OFFSET/BIAS CURRENT vs TEMPERATURE

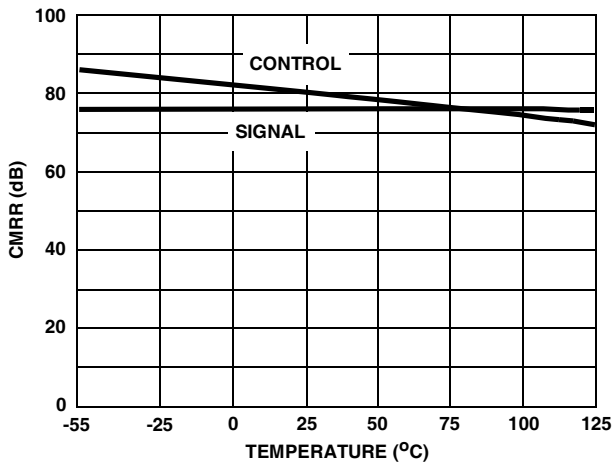

FIGURE 14. SIGNAL/CONTROL CMRR vs TEMPERATURE

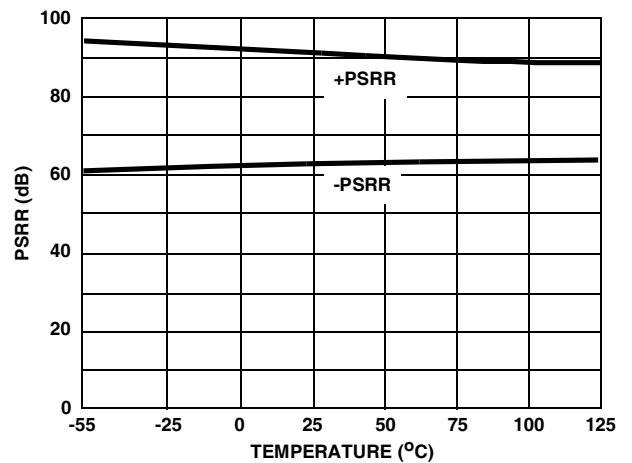

FIGURE 15. PSRR vs TEMPERATURE

Typical Performance Curves $V_S = \pm 15V, T_A = 25^\circ C$ (Continued)

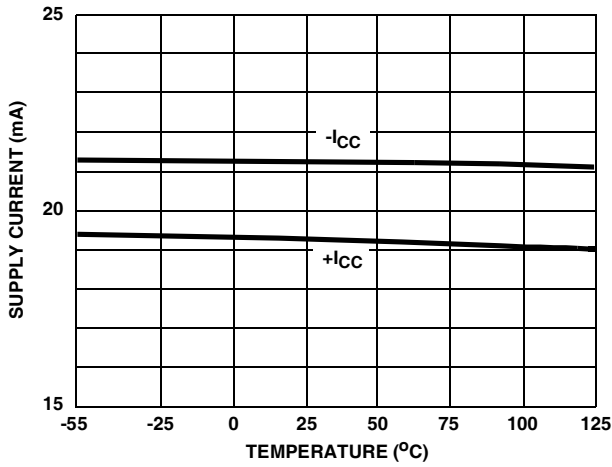

FIGURE 16. I_{CC} vs TEMPERATURE

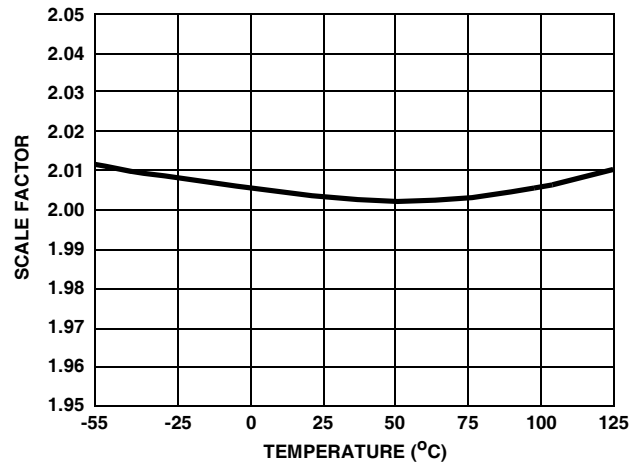

FIGURE 17. SCALE FACTOR vs TEMPERATURE

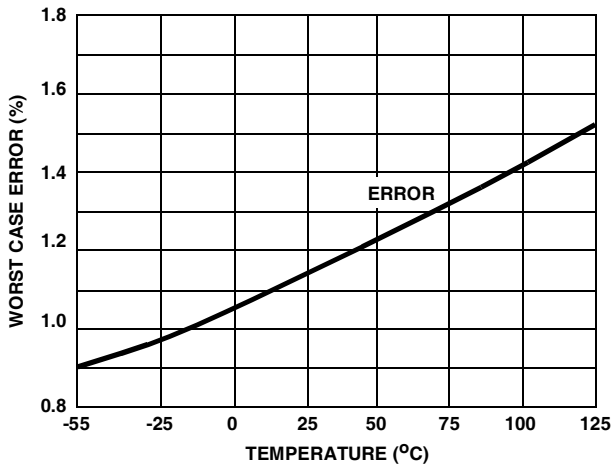

FIGURE 18. WORST CASE MULTIPLICATION ERROR vs TEMPERATURE

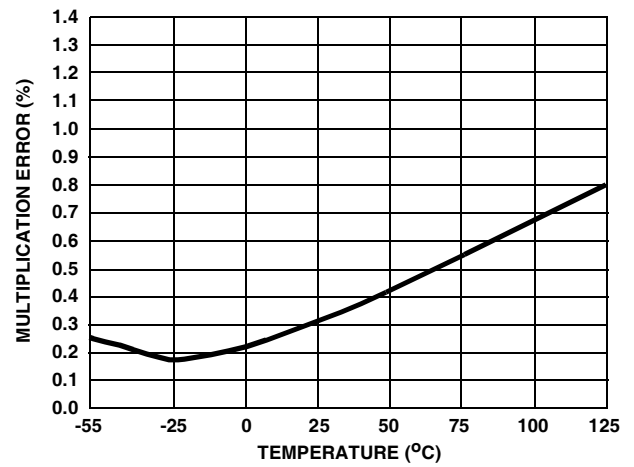

FIGURE 19. MULTIPLICATION ERROR vs TEMPERATURE

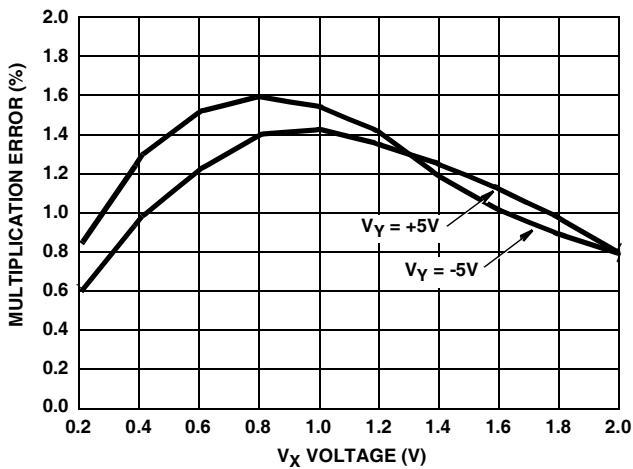

FIGURE 20. MULTIPLICATION ERROR vs V_X

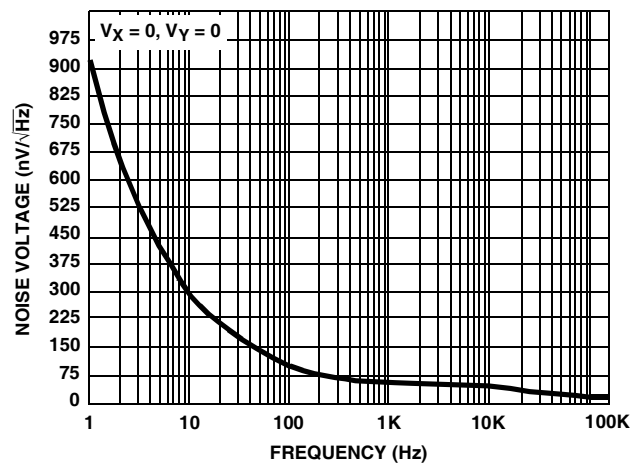

FIGURE 21. VOLTAGE NOISE DENSITY