



Integrated  
Circuit  
Systems, Inc.

**PRELIMINARY**

# ICS844008I-15

## FEMTOCLOCKS™ CRYSTAL-TO-LVDS FREQUENCY SYNTHESIZER

### GENERAL DESCRIPTION



The ICS844008I-15 is an 8 output LVDS Synthesizer optimized to generate PCI Express reference clock frequencies and is a member of the HiPerClocks™ family of high performance clock solutions from ICS. Using a 25MHz parallel resonant crystal, the following frequencies can be generated based on F\_SEL pin: 100MHz or 125MHz. The ICS844008I-15 uses ICS' 3<sup>rd</sup> generation low phase noise VCO technology and can achieve <1ps typical rms phase jitter, easily meeting PCI Express jitter requirements. The ICS844008I-15 is packaged in a 32-pin LQFP package.

### FEATURES

- Eight LVDS outputs
- Crystal oscillator interface
- Supports the following output frequencies: 100MHz or 125MHz
- VCO: 500MHz
- RMS phase jitter @ 125MHz, using a 25MHz crystal (1.875MHz - 20MHz): 0.42ps (typical)
- Full 3.3V supply modes
- -40°C to 85°C ambient operating temperature
- Available in both standard and lead-free RoHS compliant packages

FREQUENCY SELECT FUNCTION TABLE

Input					Output Frequency (MHz)
Input Frequency (MHz)	F_SEL	M Divider Value	N Divider Value	M/N Divider Value	
25MHz	0	20	4	5	125
25MHz	1	20	5	4	100

### PIN ASSIGNMENT

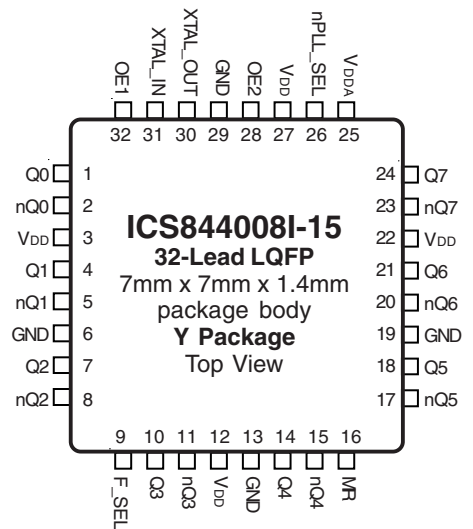

### BLOCK DIAGRAM

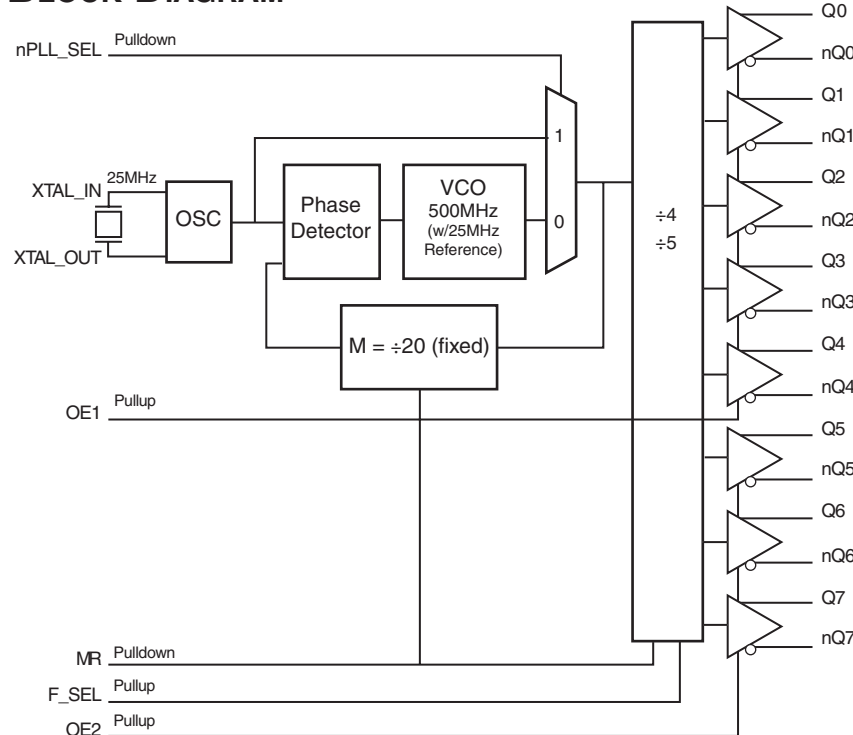

The Preliminary Information presented herein represents a product in prototyping or pre-production. The noted characteristics are based on initial product characterization. Integrated Circuit Systems, Incorporated (ICS) reserves the right to change any circuitry or specifications without notice.



**TABLE 1. PIN DESCRIPTIONS**

Number	Name	Type		Description
1, 2	Q0, nQ0	Output		Differential output pair. LVDS interface levels.
3, 12, 22, 27	V <sub>DD</sub>	Power		Core supply pin.
4, 5	Q1, nQ1	Output		Differential output pair. LVDS interface levels.
6, 13, 19, 29	GND	Power		Power supply ground.
7, 8	Q2, nQ2	Output		Differential output pair. LVDS interface levels.
9	F_SEL	Input	Pullup	Frequency select pin LVCMOS/LVTTL interface levels.
10, 11	Q3, nQ3	Output		Differential output pair. LVDS interface levels.
14, 15	Q4, nQ4	Output		Differential output pair. LVDS interface levels.
16	MR	Input	Pulldown	Active HIGH Master Reset. When logic HIGH, the internal dividers are reset causing the true outputs Qx to go low and the inverted outputs nQx to go high. When logic LOW, the internal dividers and the outputs are enabled. LVCMOS/LVTTL interface levels.
17, 18	nQ5, Q5	Output		Differential output pair. LVDS interface levels.
20, 21	nQ6, Q6	Output		Differential output pair. LVDS interface levels.
23, 24	nQ7, Q7	Output		Differential output pair. LVDS interface levels.
25	V <sub>DDA</sub>	Power		Analog supply pin.
26	nPLL_SEL	Input	Pulldown	Selects between the PLL and REF_CLK as input to the dividers. When LOW, selects PLL (PLL Enable). When HIGH, deselects the reference clock (PLL Bypass). LVCMOS/LVTTL interface levels.
28	OE2	Input	Pullup	Output enable for Q5/nQ5:Q7/nQ7 outputs. LVCMOS/LVTTL interface levels.
30, 31	XTAL_OUT, XTAL_IN	Input		Parallel resonant crystal interface. XTAL_OUT is the output, XTAL_IN is the input.
32	OE1	Input	Pullup	Output enable for Q0/nQ0:Q4/nQ4 outputs. LVCMOS/LVTTL interface levels.

NOTE: *Pullup* refers to internal input resistors. See Table 2, Pin Characteristics, for typical values.

**TABLE 2. PIN CHARACTERISTICS**

Symbol	Parameter	Test Conditions	Minimum	Typical	Maximum	Units
C <sub>IN</sub>	Input Capacitance			4		pF
R <sub>PULLDOWN</sub>	Input Pulldown Resistor			51		kΩ
R <sub>PULLUP</sub>	Input PullUP Resistor			51		kΩ

**TABLE 3A. OE1 FUNCTION TABLE**

Input	Outputs
OE1	Q0:Q4, nQ0:nQ4
0	Places outputs in Hi-Z state
1	Normal operation

**TABLE 3B. OE2 FUNCTION TABLE**

Input	Outputs
OE2	Q5:Q7, nQ5:nQ7
0	Places outputs in Hi-Z state
1	Normal operation



**ABSOLUTE MAXIMUM RATINGS**

Supply Voltage, $V_{DD}$	4.6V
Inputs, $V_i$	-0.5V to $V_{DD} + 0.5V$
Outputs, $I_o$	
Continuous Current	10mA
Surge Current	15mA
Package Thermal Impedance, $\theta_{JA}$	47.9°C/W (0 lfpm)
Storage Temperature, $T_{STG}$	-65°C to 150°C

NOTE: Stresses beyond those listed under Absolute Maximum Ratings may cause permanent damage to the device. These ratings are stress specifications only. Functional operation of product at these conditions or any conditions beyond those listed in the *DC Characteristics* or *AC Characteristics* is not implied. Exposure to absolute maximum rating conditions for extended periods may affect product reliability.

**TABLE 4A. POWER SUPPLY DC CHARACTERISTICS,  $V_{DD} = 3.3V \pm 5\%$ ,  $T_A = -40^\circ C$  TO  $85^\circ C$**

Symbol	Parameter	Test Conditions	Minimum	Typical	Maximum	Units
$V_{DD}$	Core Supply Voltage		3.135	3.3	3.465	V
$V_{DDA}$	Analog Supply Voltage		3.135	3.3	3.465	V
$I_{DD}$	Power Supply Current			122		mA
$I_{DDA}$	Analog Supply Current			11		mA

**TABLE 4B. LVCMOS / LVTTTL DC CHARACTERISTICS,  $V_{DD} = 3.3V \pm 5\%$ ,  $T_A = -40^\circ C$  TO  $85^\circ C$**

Symbol	Parameter	Test Conditions	Minimum	Typical	Maximum	Units
$V_{IH}$	Input High Voltage	$V_{DD} = 3.3V$	2		$V_{DD} + 0.3$	V
$V_{IL}$	Input Low Voltage	$V_{DD} = 3.3V$	-0.3		0.8	V
$I_{IH}$	Input High Current	MR, nPLL_SEL	$V_{DD} = V_{IN} = 3.465$		150	$\mu A$
		OE1, OE2, F_SEL	$V_{DD} = V_{IN} = 3.465$		5	$\mu A$
$I_{IL}$	Input Low Current	MR, nPLL_SEL	$V_{DD} = 3.465V, V_{IN} = 0V$	-5		$\mu A$
		OE1, OE2, F_SEL	$V_{DD} = 3.465V, V_{IN} = 0V$	-150		$\mu A$

**TABLE 4C. LVDS DC CHARACTERISTICS,  $V_{DD} = 3.3V \pm 5\%$ ,  $T_A = -40^\circ C$  TO  $85^\circ C$**

Symbol	Parameter	Test Conditions	Minimum	Typical	Maximum	Units
$V_{OD}$	Differential Output Voltage			350		mV
$\Delta V_{OD}$	$V_{OD}$ Magnitude Change			40		mV
$V_{OS}$	Offset Voltage			1.25		V
$\Delta V_{OS}$	$V_{OS}$ Magnitude Change			50		mV



**TABLE 5. CRYSTAL CHARACTERISTICS**

Parameter	Test Conditions	Minimum	Typical	Maximum	Units
Mode of Oscillation		Fundamental			
Frequency		22.4	25	27.2	MHz
Parts per Million (ppm); NOTE 1				100	ppm
Equivalent Series Resistance (ESR)				50	$\Omega$
Shunt Capacitance				7	pF
Drive Level				100	$\mu$ W

NOTE: Characterized using an 18pF parallel resonant crystal.

NOTE 1: When used with recommended 50ppm crystal and external trim caps adjusted for user PC board.

**TABLE 6. AC CHARACTERISTICS,  $V_{DD} = 3.3V \pm 5\%$ ,  $T_A = -40^\circ C$  TO  $85^\circ C$**

Symbol	Parameter	Test Conditions	Minimum	Typical	Maximum	Units
$f_{OUT}$	Output Frequency	FSEL = 0		125		MHz
		FSEL = 1		100		MHz
$t_{sk(o)}$	Output Skew; NOTE 1, 2			TBD	50	ps
$f_{jit(cc)}$	Cycle-to-Cycle Jitter			25	50	ps
$f_{jit}(\emptyset)$	RMS Phase Jitter (Random); NOTE 3	125MHz, (1.875MHz - 20MHz)		0.42	1	ps
		100MHz, (1.875MHz - 20MHz)		0.46	1	ps
$t_R / t_F$	Output Rise/Fall Time	20% to 80%	200	330	650	ps
odc	Output Duty Cycle		48	50	52	%

Minimum and Maximum values are design target specs.

NOTE 1: Defined as skew between outputs at the same supply voltages and with equal load conditions.

Measured at  $V_{DD}/2$ .

NOTE 2: This parameter is defined in accordance with JEDEC Standard 65.

NOTE 3: Please refer to the Phase Noise Plot.



**TYPICAL PHASE NOISE AT 125MHz AT 3.3V**

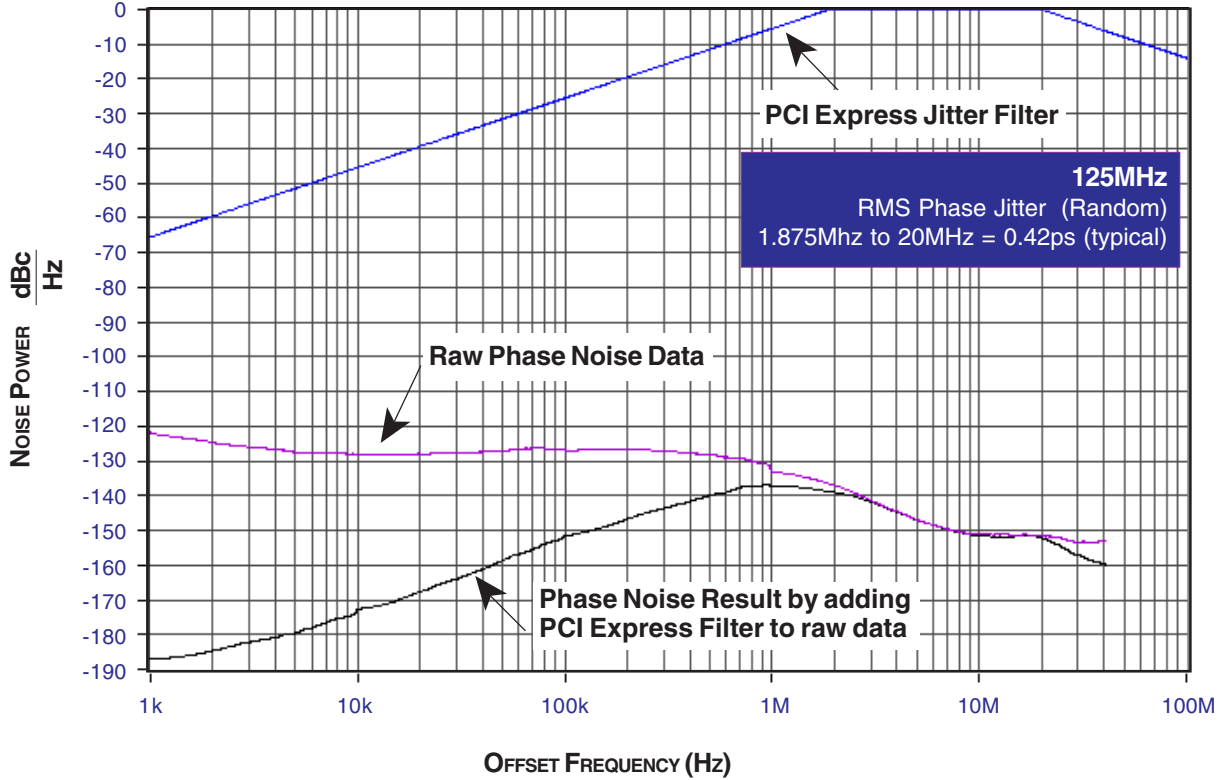



**PARAMETER MEASUREMENT INFORMATION**

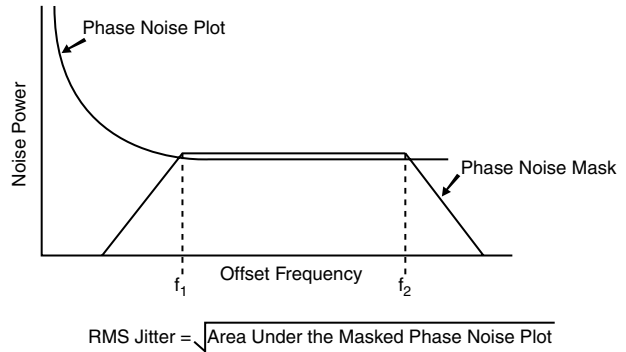
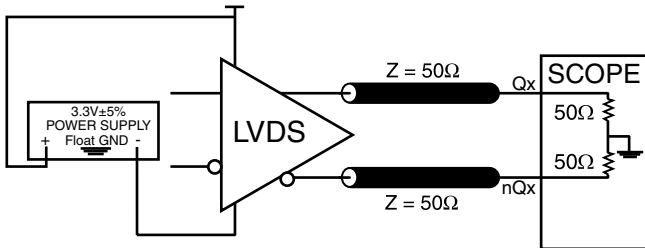

**3.3V CORE/3.3V OUTPUT LOAD AC TEST CIRCUIT**

**RMS PHASE JITTER**

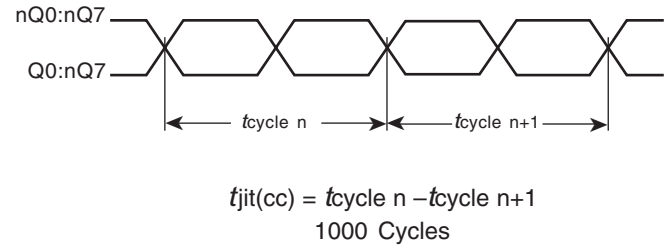
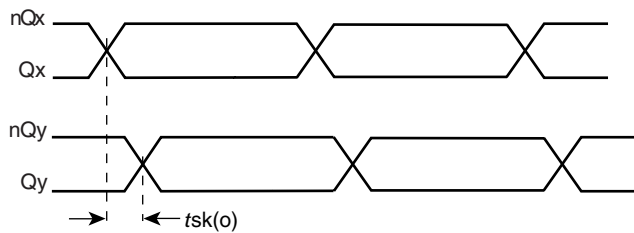

**OUTPUT SKEW**

**CYCLE-TO-CYCLE JITTER**

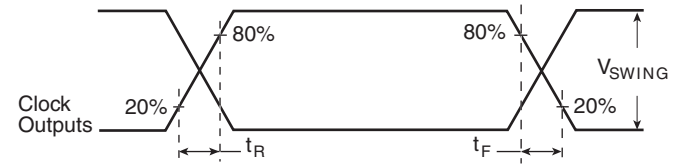
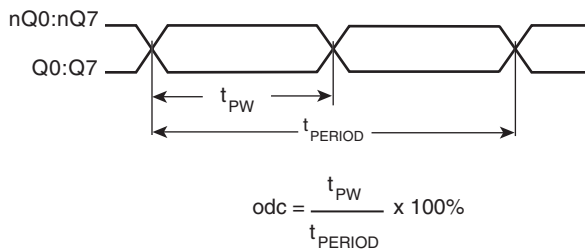

**OUTPUT DUTY CYCLE/PULSE WIDTH/PERIOD**

**OUTPUT RISE/FALL TIME**

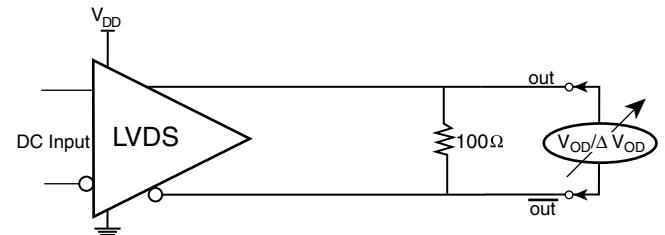
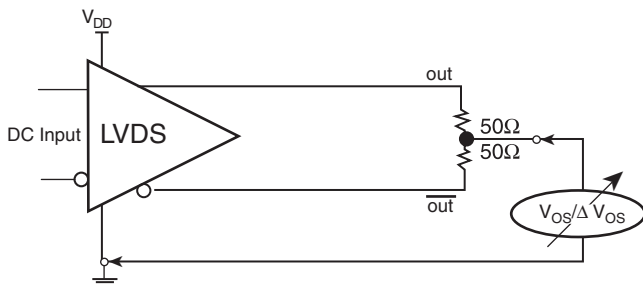

**OFFSET VOLTAGE SETUP**

**DIFFERENTIAL OUTPUT VOLTAGE SETUP**



## APPLICATION INFORMATION

### POWER SUPPLY FILTERING TECHNIQUES

As in any high speed analog circuitry, the power supply pins are vulnerable to random noise. The ICS844008I-15 provides separate power supplies to isolate any high switching noise from the outputs to the internal PLL.  $V_{DD}$  and  $V_{DDA}$  should be individually connected to the power supply plane through vias, and bypass capacitors should be used for each pin. To achieve optimum jitter performance, power supply isolation is required. *Figure 1* illustrates how a  $10\Omega$  resistor along with a  $10\mu\text{F}$  and a  $.01\mu\text{F}$  bypass capacitor should be connected to each  $V_{DDA}$ .

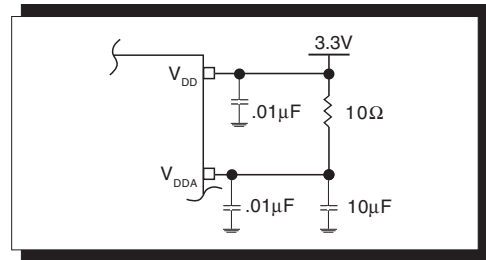
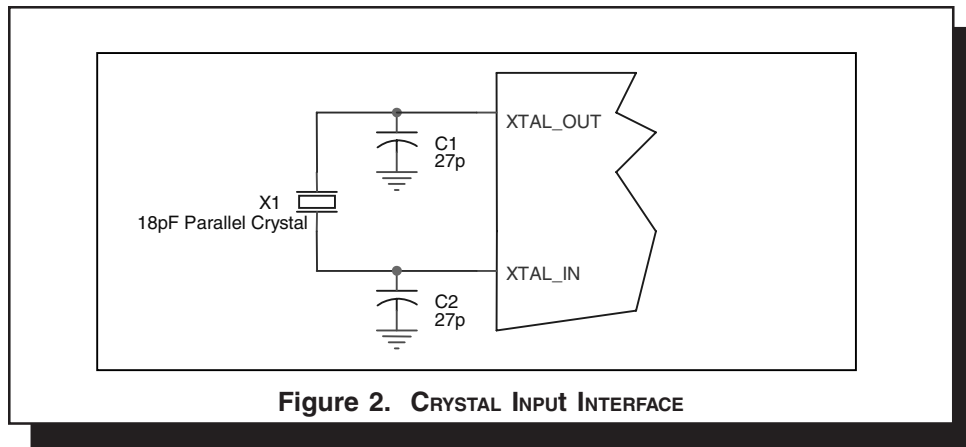

**FIGURE 1. POWER SUPPLY FILTERING**

### CRYSTAL INPUT INTERFACE

The ICS844008I-15 has been characterized with 18pF parallel resonant crystals. The capacitor values shown in

*Figure 2* below were determined using a 25MHz parallel resonant crystal and were chosen to minimize the ppm error.



**Figure 2. CRYSTAL INPUT INTERFACE**



**RECOMMENDATIONS FOR UNUSED INPUT AND OUTPUT PINS**

**INPUTS:**

**LVC MOS CONTROL PINS:**

All control pins have internal pull-ups or pull-downs; additional resistance is not required but can be added for additional protection. A 1kΩ resistor can be used.

**OUTPUTS:**

**LVDS**

All unused LVDS output pairs can be either left floating or terminated with 100Ω across. If they are left floating, we recommend that there is no trace attached.

**3.3V LVDS DRIVER TERMINATION**

A general LVDS interface is shown in *Figure 3*. In a 100Ω differential transmission line environment, LVDS drivers require a matched load termination of 100Ω across near

the receiver input. For a multiple LVDS outputs buffer, if only partial outputs are used, it is recommended to terminate the unused outputs.

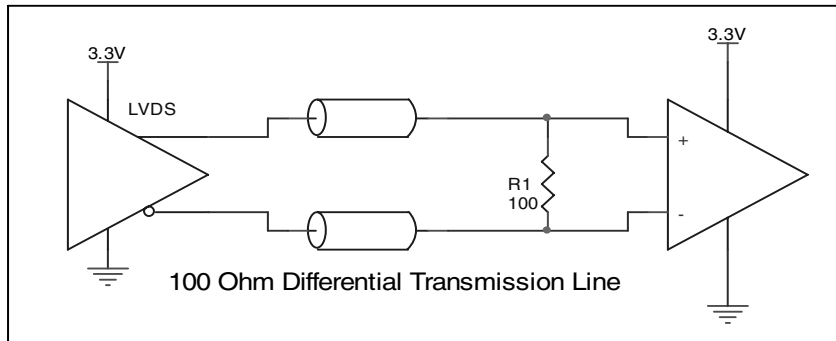

**FIGURE 3. TYPICAL LVDS DRIVER TERMINATION**





## POWER CONSIDERATIONS

This section provides information on power dissipation and junction temperature for the ICS844008I-15. Equations and example calculations are also provided.

### 1. Power Dissipation.

The total power dissipation for the ICS844008I-15 is the sum of the core power plus the power dissipated in the load(s). The following is the power dissipation for  $V_{DD} = 3.3V + 5\% = 3.465V$ , which gives worst case results.

- $\text{Power (core)}_{MAX} = V_{DD\_MAX} * (I_{DD\_MAX} + I_{DDA\_MAX}) = 3.465V * (122mA + 11mA) = \mathbf{460.85mW}$

### 2. Junction Temperature.

Junction temperature,  $T_j$ , is the temperature at the junction of the bond wire and bond pad and directly affects the reliability of the device. The maximum recommended junction temperature for HiPerClockS™ devices is 125°C.

The equation for  $T_j$  is as follows:  $T_j = \theta_{JA} * Pd\_total + T_A$

$T_j$  = Junction Temperature

$\theta_{JA}$  = Junction-to-Ambient Thermal Resistance

$Pd\_total$  = Total Device Power Dissipation (example calculation is in section 1 above)

$T_A$  = Ambient Temperature

In order to calculate junction temperature, the appropriate junction-to-ambient thermal resistance  $\theta_{JA}$  must be used. Assuming a moderate air flow of 200 linear feet per minute and a multi-layer board, the appropriate value is 42.1°C/W per Table 7 below.

Therefore,  $T_j$  for an ambient temperature of 85°C with all outputs switching is:

$$85^\circ\text{C} + 0.461\text{W} * 42.1^\circ\text{C/W} = 104.4^\circ\text{C}. \text{ This is below the limit of } 125^\circ\text{C}.$$

This calculation is only an example.  $T_j$  will obviously vary depending on the number of loaded outputs, supply voltage, air flow, and the type of board (single layer or multi-layer).

**TABLE 7. THERMAL RESISTANCE  $\theta_{JA}$  FOR 32-LEAD LQFP, FORCED CONVECTION**

$\theta_{JA}$ by Velocity (Linear Feet per Minute)			
	0	200	500
Single-Layer PCB, JEDEC Standard Test Boards	67.8°C/W	55.9°C/W	50.1°C/W
Multi-Layer PCB, JEDEC Standard Test Boards	47.9°C/W	42.1°C/W	39.4°C/W

**NOTE:** Most modern PCB designs use multi-layered boards. The data in the second row pertains to most designs.



Integrated  
Circuit  
Systems, Inc.

# PRELIMINARY

**ICS844008I-15**  
FEMTOCLOCKS™ CRYSTAL-TO-  
LVDS FREQUENCY SYNTHESIZER

## RELIABILITY INFORMATION

TABLE 8.  $\theta_{JA}$  vs. AIR FLOW TABLE FOR 32 LEAD LQFP

$\theta_{JA}$ by Velocity (Linear Feet per Minute)			
	0	200	500
Single-Layer PCB, JEDEC Standard Test Boards	67.8°C/W	55.9°C/W	50.1°C/W
Multi-Layer PCB, JEDEC Standard Test Boards	47.9°C/W	42.1°C/W	39.4°C/W

**NOTE:** Most modern PCB designs use multi-layered boards. The data in the second row pertains to most designs.

### TRANSISTOR COUNT

The transistor count for ICS844008I-15 is: TBD



Integrated  
Circuit  
Systems, Inc.

**PRELIMINARY**

**ICS844008I-15**  
FEMTOCLOCKS™ CRYSTAL-TO-  
LVDS FREQUENCY SYNTHESIZER

**PACKAGE OUTLINE - Y SUFFIX FOR 32 LEAD LQFP**

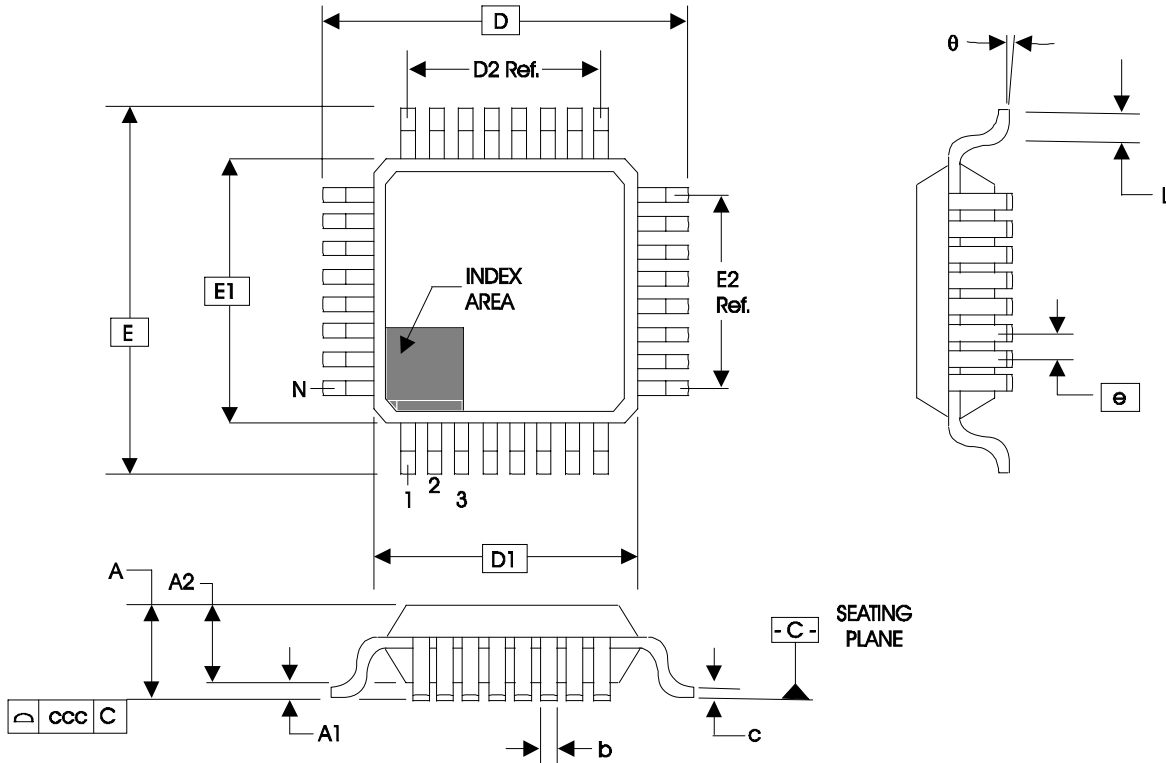

**TABLE 9. PACKAGE DIMENSIONS**

JEDEC VARIATION ALL DIMENSIONS IN MILLIMETERS			
SYMBOL	BBA		
	MINIMUM	NOMINAL	MAXIMUM
N	32		
A	--	--	1.60
A1	0.05	--	0.15
A2	1.35	1.40	1.45
b	0.30	0.37	0.45
c	0.09	--	0.20
D	9.00 BASIC		
D1	7.00 BASIC		
D2	5.60 Ref.		
E	9.00 BASIC		
E1	7.00 BASIC		
E2	5.60 Ref.		
e	0.80 BASIC		
L	0.45	0.60	0.75
theta	0°	--	7°
ccc	--	--	0.10

Reference Document: JEDEC Publication 95, MS-026



Integrated  
Circuit  
Systems, Inc.

**PRELIMINARY**

**ICS844008I-15**  
FEMTOCLOCKS™ CRYSTAL-TO-  
LVDS FREQUENCY SYNTHESIZER

**TABLE 10. ORDERING INFORMATION**

Part/Order Number	Marking	Package	Shipping Packaging	Temperature
ICS844008AYI-15	ICS44008AI15	32 Lead LQFP	tube	-40°C to 85°C
ICS844008AYI-15T	ICS44008AI15	32 Lead LQFP	1000 tape & reel	-40°C to 85°C
ICS844008AYI-15LF	TBD	32 Lead "Lead-Free" LQFP	tube	-40°C to 85°C
ICS844008AYI-15LFT	TBD	32 Lead "Lead-Free" LQFP	1000 tape & reel	-40°C to 85°C

NOTE: Parts that are ordered with an "LF" suffix to the part number are the Pb-Free configuration and are RoHS compliant.

The ICS logo is a registered trademark, and HiPerClockS is a trademark of Integrated Circuit Systems, Inc. All other trademarks are the property of their respective owners and may be registered in certain jurisdictions.

While the information presented herein has been checked for both accuracy and reliability, Integrated Circuit Systems, Incorporated (ICS) assumes no responsibility for either its use or for infringement of any patents or other rights of third parties, which would result from its use. No other circuits, patents, or licenses are implied. This product is intended for use in normal commercial and industrial applications. Any other applications such as those requiring high reliability or other extraordinary environmental requirements are not recommended without additional processing by ICS. ICS reserves the right to change any circuitry or specifications without notice. ICS does not authorize or warrant any ICS product for use in life support devices or critical medical instruments.