

GLASS PASSIVATED RECTIFIERS

VOLTAGE RANGE: 50 --- 1000 V

CURRENT: 3.0 A

FEATURES

- ◇ Glass passivated junction
- ◇ Low leakage
- ◇ Low forward voltage drop
- ◇ High current capability
- ◇ Easily cleaned with alcohol, Isopropanol and similar solvents
- ◇ The plastic material carries U/L recognition 94V-0

MECHANICAL DATA

- ◇ Case: JEDEC DO-27, molded plastic
- ◇ Terminals: Axial lead, solderable per MIL-STD-202, Method 208
- ◇ Polarity: Color band denotes cathode
- ◇ Weight: 0.041 ounces, 1.15 grams
- ◇ Mounting position: Any

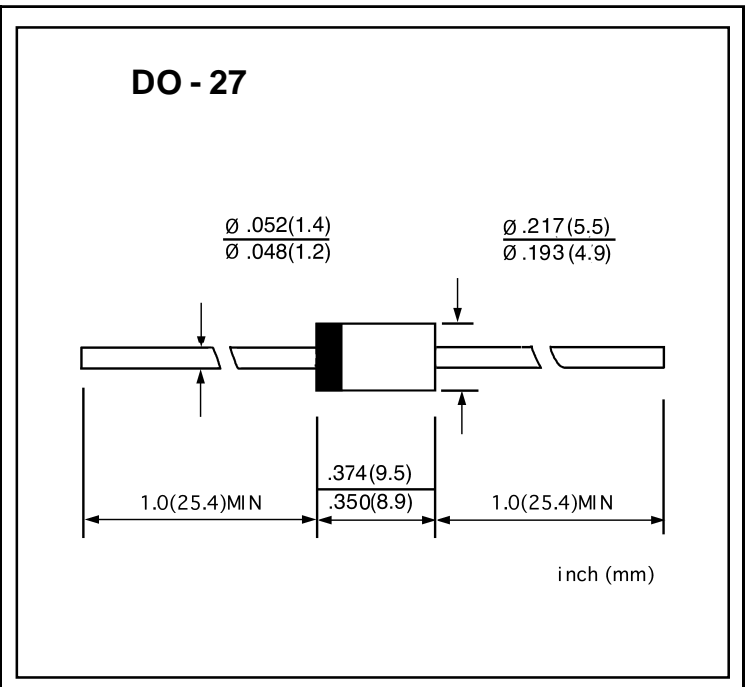

MAXIMUM RATINGS AND ELECTRICAL CHARACTERISTICS

Ratings at 25°C ambient temperature unless otherwise specified.

Single phase, half wave, 60 Hz, resistive or inductive load. For capacitive load, derate by 20%.

		UF 5400G	UF 5401G	UF 5402G	UF 5403G	UF 5404G	UF 5405G	UF 5406G	UF 5407G	UF 5408G	UNITS	
Maximum recurrent peak reverse voltage	V_{RRM}	50	100	200	300	400	500	600	800	1000	V	
Maximum RMS voltage	V_{RMS}	35	70	140	210	280	350	420	560	700	V	
Maximum DC blocking voltage	V_{DC}	50	100	200	300	400	500	600	800	1000	V	
Maximum average forward rectified current 9.5mm lead length, @ $T_A=75^\circ C$	$I_{F(AV)}$	3.0									A	
Peak forward surge current 8.3ms single half-sine-wave superimposed on rated load @ $T_J=125^\circ C$	I_{FSM}	150.0									A	
Maximum instantaneous forward voltage at 3.0 A	V_F	1.0				1.7					V	
Maximum reverse current @ $T_A=25^\circ C$ at rated DC blocking voltage @ $T_A=100^\circ C$	I_R	10.0					100.0					μA
Maximum reverse recovery time (Note1)	t_{rr}	50				75					ns	
Typical junction capacitance (Note2)	C_J	45									pF	
Typical thermal resistance (Note3)	$R_{\theta JA}$	20									$^\circ C/W$	
Operating junction temperature range	T_J	- 55 ---- + 175									$^\circ C$	
Storage temperature range	T_{STG}	- 55 ---- + 175									$^\circ C$	

NOTE: 1. Measured with $I_F=0.5A$, $I_R=1A$, $I_{rr}=0.25A$.

2. Measured at 1.0MHZ and applied reverse voltage of 4.0V DC.

3. Thermal resistance junction to ambient.

www.galaxycn.com

FIG.1 -- TEST CIRCUIT DIAGRAM AND REVERSE RECOVERY TIME CHARACTERISTIC

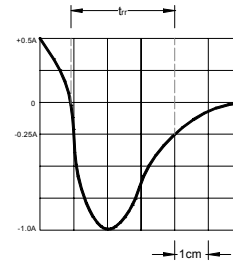
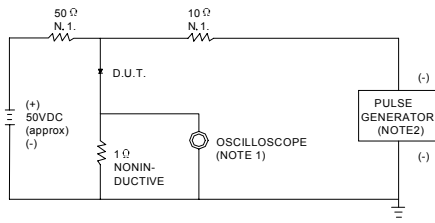

NOTES: 1. RISE TIME = 7ns MAX. INPUT IMPEDANCE = 1MΩ .22pF.
2. RISE TIME = 10ns MAX. SOURCE IMPEDANCE = 50 Ω.

SET TIME BASE FOR 10/20 ns/cm

FIG.2 -- TYPICAL FORWARD CHARACTERISTIC

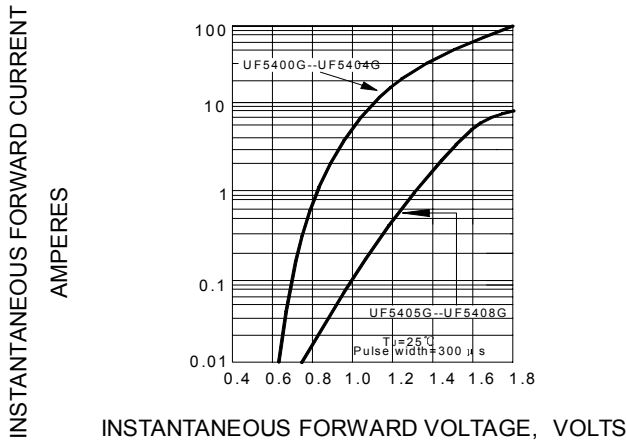

FIG.3 -- FORWARD DERATING CURVE

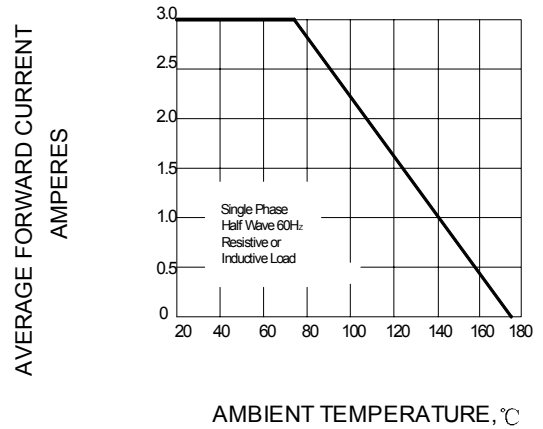

FIG.4 -- TYPICAL JUNCTION CAPACITANCE

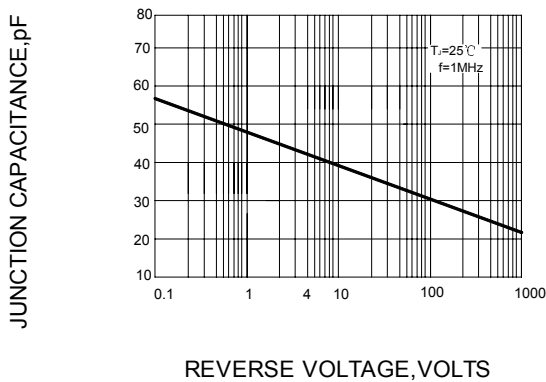

FIG.5 -- PEAK FORWARD SURGE CURRENT

