

**NEW**

# Radiometrix

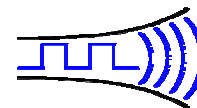

Hartcran House, 231 Kenton Lane, Harrow, HA3 8RP, England

Issue: 1, 28 February 2008

Tel: +44 (0) 20 8909 9595, Fax: +44 (0) 20 8909 2233

**KRX416**

## Code-hopping decoder with 4 outputs

*Key-code Receiver 416 is a single IC solution for decrypting and decoding Radiometrix code-hopping transmitters. The device will retain the identities of up to 16 code-hopping transmitters, even when the power supply is removed. It is specifically designed to be used in RF keyless remote control applications and is available in 18pin SO and DIL packages.*



Figure 1: KRX416 in 18 pin DIL package

### Features

- Operating voltage (temperature):  
4.5V-5.5V (-40°C to +85°C)
- Draws <2mA without external load
- 4 digital outputs (on/off)
- Learn input pin (activate to store a transmitter identity)
- Learn output pin (indication of a Learnt transmitter)
- Mode select pin – choice of two output modes
- Internal non-volatile memory for learning up to 16 different transmitters
- Hop-code decryption ensures that only valid transmissions are acted upon
- Manchester decoding at 1250bps (+25% -50%)
- Suitable for use with Radiometrix FM radio-receiver modules e.g. RX2A
- Internal clock – no external oscillator components needed
- Internal supply monitoring (brown-out = self-reset)
- Minimum external component requirement
- Compatible with Radiometrix code-hopping transmitters, e.g. KTX2

### Applications

- Security and Alarm systems
- Status reporting and monitoring systems
- RF Remote control systems
- Industrial controls
- HVAC controls
- Door entry systems
- Simple On/Off switching

## Typical Application Circuit

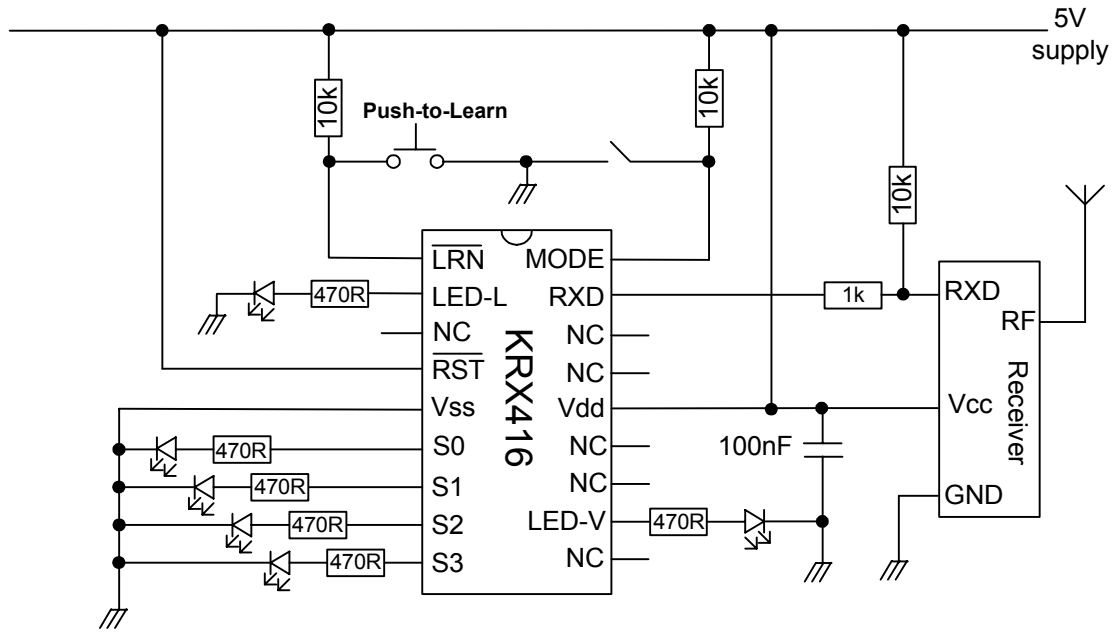

Figure 2: KRX416 Function-Code display - example circuit

Pin	Name	Input/Output	Description
1	LRN	Input	Normally held-high: Momentarily connect to 0V to enter Learn Mode – stays in Learn Mode until a compatible Radiometrix transmitter is successfully learned or time-out occurs in approx. 18s.  Connect to 0V for more than 10s (approx.) to clear NV memory: this removes <b>all</b> learnt transmitters.
2	LED-L	Output <sup>1</sup>	Active high during Learning Phase – A code-hopping transmitter is Learnt during this time by receiving and decoding its transmission. Pin 2 then cycles low-high-low for a short period (flashes the LED) to indicate that a transmitter has been Learned.  If Pin 1 is held low >10s Pin 2 goes low then momentarily high again (when Pin 1 returned high) to indicate NV Memory has been cleared.  Active high (10ms or for as long as S0-S3 are active) when <i>not</i> in Learn Mode to indicate that the IC has decoded a Function Code (S0-S3 state) that was used previously in Learning a Transmitter.
3	NC	-	Do not connect anything to this pin
4	RST	Input	Normally held high. Taken low this pin will Reset the IC. The NV Memory is unaffected.
5	Vss	Supply	Supply Ground
6	S0	Output <sup>1</sup>	Function Code output S0 – active high 10ms pulse <sup>2</sup> or a 350-500ms pulse and held high for repeat messages (see “Mode” description)
7	S1	Output <sup>1</sup>	Function Code output S1 – operation as above
8	S2	Output <sup>1</sup>	Function Code output S2 – operation as above
9	S3	Output <sup>1</sup>	Function Code output S3 – operation as above
10	NC	-	Do not connect anything to this pin
11	LED-V	Output <sup>1</sup>	Active high when the received message indicates that the Transmitter encoder power supply is below 3.8V (approx.)
12, 13	NC	-	Do not connect anything to this pin
14	Vdd	Supply	4.5-5.5V supply (decouple with 0.1µF close to IC)
15, 16	NC	-	Do not connect anything to this pin
17	RXD	Input	Data input from receiver, also connect to Vdd via 10k (no input =1)
18	MODE	Input <sup>3</sup>	Can be held high or low. When high, outputs S0-S3 are active only for a brief period but when Mode is held low a “latency” is effected.

**Notes:**

1. Absolute maximum source/sink current from each S0-S3, LED-L, LED-V pins is 25mA.
2. Output pulse length is between 10 and 12ms
3. Can be held high or low. When high, the outputs S0-S3 will be active only for a brief period (see note 2), even if the same message continues to be received over and over again – this is intended as a control pulse for interfacing to additional logic or a microcontroller and is the most basic and secure way to use the decoder.

When low, the outputs will be active for 350-500ms (approx.) and this long period allows “refreshing” by repeat messages from the same transmitter. In this way, repeated transmissions with the same code (e.g. a user holding down a function-code button at the transmitter) will cause the respective decoder output also to stay active, until the message ceases to be received within the 350-500ms window. The function-code may change (i.e. be added to) but the outputs will not be cleared until reception of the message has ended.

**Data from a code-hopped message**

Transmission format is 1250bps (nominal rate) Manchester encoding. Although the function-code is only 4 bits, total message length is 67 bits. This includes a 28-bit serial number and a 32-bit encrypted hop-code. Note that the serial number and function code data is not encrypted. The correct status of the transmission is used to validate the data. This is achieved through use of the ever changing hop-code (changes for every new message) and by synchronising the KRX416 IC to the transmitter(s) in use. Put another way: the KRX416 “Learns” individual unique transmitters, as required by the user.

The hop-code is encrypted using the serial number of the transmitter plus the manufacturer code (64-bit), which is kept secret and is not transmitted. The function-code (S0-S3) appears twice in the message and forms a part of the hop-code encryption process.

If the KRX416 loses synchronisation with the transmitter (e.g. repeated transmitter activation whilst out of range of the receiver) then the transmitter must be activated twice with valid and sequential hop-codes before KRX416 will allow the control to be processed. The hop-code is only valid if it is within a *forward* window of +32768 activations. This mechanism prevents “code-grabbers” from breaking the security of the system by recording and re-broadcasting old codes. Additionally, in the KRX416 a window exists allowing up to 14 transmissions to occur whilst the transmitter is out of range before two valid sequential transmissions are required to use the system. In practice a user may not notice the latter, since human reaction to the unsuccessful attempt is simply to “press the button again”.

The level of redundancy and encryption in a message mean that, in simple terms, the KRX416 will only output a function-code that has been received from a properly recognised and synchronised transmitter.

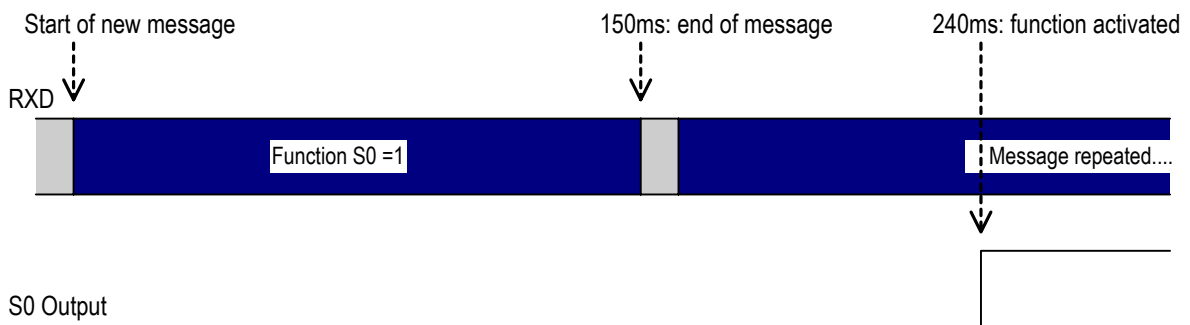

**Figure 3: Timing diagram – showing action upon receiving a message with S0 = 1**

In a typical set-up, the time delay between “button-press” at the transmitter and function activation by the KRX416 IC at the receiver is approx. ¼s.

## Application Modes

Mode	Description
1	Short output pulse – suggested for logic and microcontroller interfacing
0	Long output pulse (& held by repeated message) – simple “output follows input”. Example use: handheld remote controller

KRX416 can be used with wideband or narrowband radio modules.

## Ordering Information

KRX416-000-SS Key-code Decoder 16 transmitter learn capacity - Shrink Small Outline  
KRX416-000-SO Key-code Decoder 16 transmitter learn capacity - Small Outline  
KRX416-000-DIL Key-code Decoder 16 transmitter learn capacity - Plastic Dual In Package

# **Radiometrix Ltd**

**Hartcran House  
231 Kenton Lane  
Harrow, Middlesex  
HA3 8RP  
ENGLAND**

**Tel: +44 (0) 20 8909 9595  
Fax: +44 (0) 20 8909 2233  
sales@radiometrix.com  
www.radiometrix.com**

## **Copyright notice**

*This product data sheet is the original work and copyrighted property of Radiometrix Ltd. Reproduction in whole or in part must give clear acknowledgement to the copyright owner.*

## **Limitation of liability**

*The information furnished by Radiometrix Ltd is believed to be accurate and reliable. Radiometrix Ltd reserves the right to make changes or improvements in the design, specification or manufacture of its subassembly products without notice. Radiometrix Ltd does not assume any liability arising from the application or use of any product or circuit described herein, nor for any infringements of patents or other rights of third parties which may result from the use of its products. This data sheet neither states nor implies warranty of any kind, including fitness for any particular application. These radio devices may be subject to radio interference and may not function as intended if interference is present. We do NOT recommend their use for life critical applications.*

*The Intrastat commodity code for all our modules is: 8542 6000*

## **R&TTE Directive**

*After 7 April 2001 the manufacturer can only place finished product on the market under the provisions of the R&TTE Directive. Equipment within the scope of the R&TTE Directive may demonstrate compliance to the essential requirements specified in Article 3 of the Directive, as appropriate to the particular equipment.*

*Further details are available on The Office of Communications (Ofcom) web site:*

**<http://www.ofcom.org.uk/radiocomms/ifi/>**

*Information Requests  
Ofcom  
Riverside House  
2a Southwark Bridge Road  
London SE1 9HA  
Tel: +44 (0)845 456 3000 or 020 7981 3040  
Fax: +44 (0)20 7783 4033  
information.requests@ofcom.org.uk*

*European Radiocommunications Office (ERO)  
Peblingehus  
Nansensgade 19  
DK 1366 Copenhagen  
Tel. +45 33896300  
Fax +45 33896330  
ero@ero.dk  
www.ero.dk*