

AS5134

360 Step Programmable High Speed Magnetic Rotary Encoder

1 General Description

The AS5134 is a contactless magnetic rotary encoder for accurate angular measurement over a full turn of 360°.

It is a system-on-chip, combining integrated Hall elements, analog front end and digital signal processing in a single device.

To measure the angle, only a simple two-pole magnet, rotating over the center of the chip is required.

The absolute angle measurement provides instant indication of the magnet's angular position with a resolution of 8.5 bit = 360 positions per revolution. This digital data is available as a serial bit stream and as a PWM signal.

In addition to the angle information, the strength of the magnetic field is also available as a 6-bit code.

Data transmission can be configured for 1-wire (PWM), 2-wires (DCLK, DIO) or 3-wires (DCLK, DIO, CS).

A software programmable (OTP) zero position simplifies assembly as the zero position of the magnet does not need to be mechanically aligned.

A Power Down Mode together with fast startup and measurement cycles allows for very low average power consumption.

2 Key Features

- 360° contactless angular position encoding
- Two digital 360 step (8.5 bit) absolute outputs: Serial interface and Pulse width modulated (PWM) output
- User programmable zero position, sensitivity
- High speed: up to 30.000 rpm
- Direct measurement of magnetic field strength allows exact determination of vertical magnet distance
- Incremental Outputs ABI Quadrature: 90 ppr, step direction: 180ppr, fixed pulse width 360ppr
- BLDC Outputs UVW, selectable for 1,2,3,4,5,6 pole pairs
- Daisy-Chain mode for cascading of multiple sensors
- 9-bit multiturn counter
- Low power mode with fast startup
- Wide magnetic field input range: 20 – 80 mT
- Wide temperature range: - 40°C to +140°C
- Small Pb-free package: SSOP 20

3 Applications

The AS5134 is suitable for contactless rotary position sensing, rotary switches (human machine interface), AC/DC motor position control and Brushless DC motor position control.

Figure 1. Block Diagram

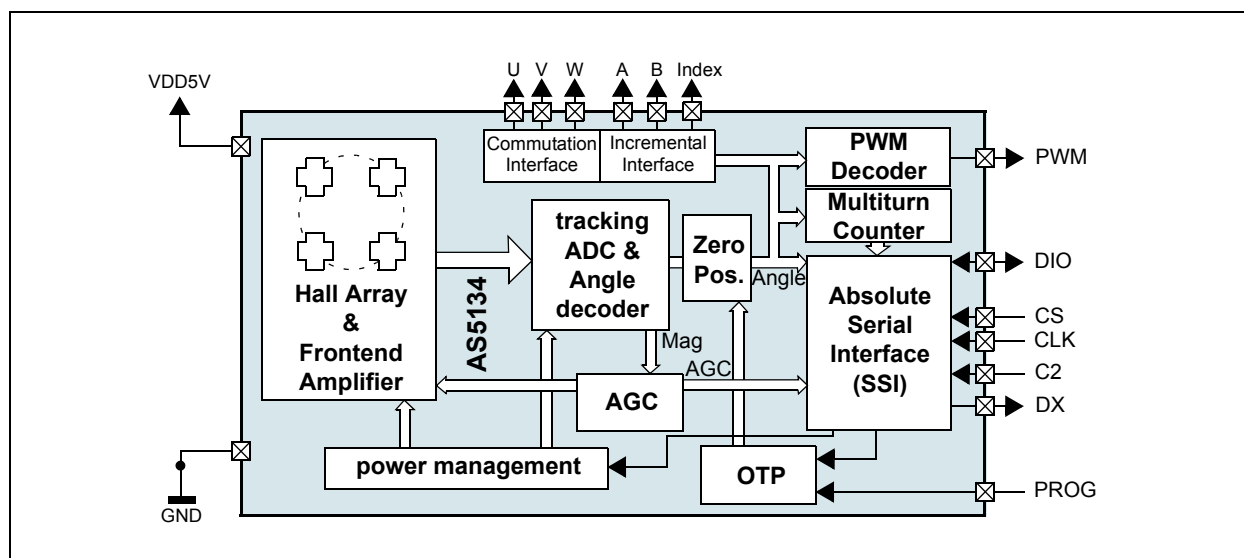

Contents

1	General Description	1
2	Key Features	1
3	Applications	1
4	Pin Assignments	3
	Pin Descriptions	3
5	Absolute Maximum Ratings	4
6	Electrical Characteristics	5
	Timing Characteristics	7
7	Detailed Description	8
	Connecting the AS5134	8
	Serial 3-Wire R/W Connection	8
	Serial 3-Wire Read-only Connection	9
	Serial 2-Wire Connection (R/W Mode)	10
	Serial 2-Wire Differential SSI Connection	11
	1-Wire PWM Connection	12
	Analog Output	12
	Analog Sin/Cos Outputs with External Interpolator	13
	Quadrature A/B/Index Output	13
	Brushless DC Motor Commutation Mode	14
	Serial Synchronous Interface (SSI)	15
	AS5134 Programming	16
	OTP Programming Connection	16
	Programming Verification	16
	AS5134 Status Indicators	17
	C2 Status Bit	17
	Lock Status Bit	17
	Magnetic Field Strength Indicators	18
	Multi Turn Counter	18
	High Speed Operation	19
	Propagation Delay	19
	ADC Sampling Rate	19
	Chip Internal Lowpass Filtering	19
	Digital Readout Rate	20
	Total Propagation Delay of the AS5134	20
	Reduced Power Modes	20
	Low/Mid Power Mode	20
	Power Cycling Mode	21
8	Application Information	23
	Benefits of AS5134	23
9	Package Drawings and Markings	26
	Recommended PCB Footprint	27
10	Ordering Information	28

4 Pin Assignments

Figure 2. Pin Assignments (Top View)

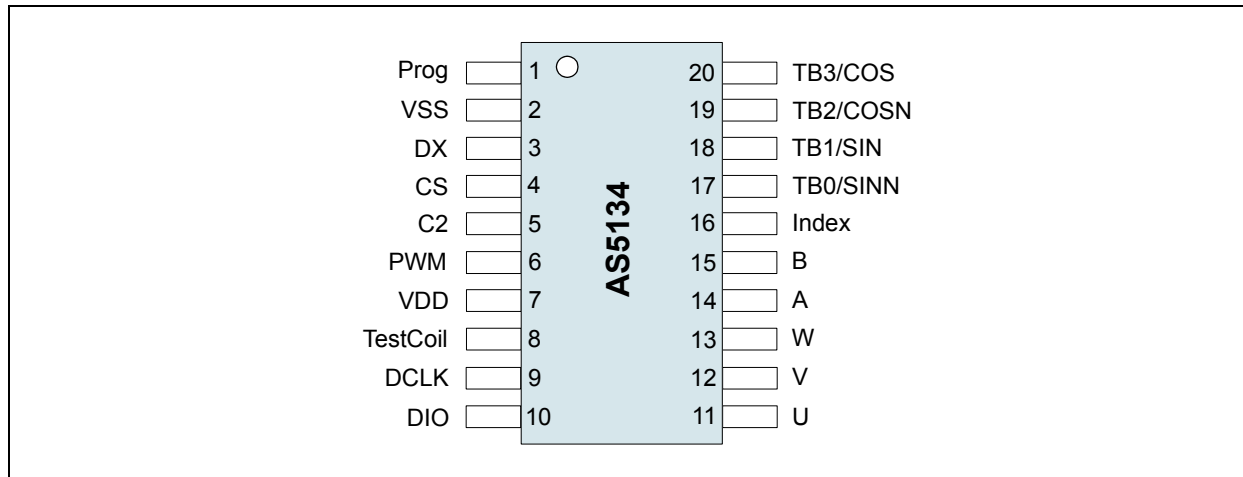

Pin Descriptions

Table 1. Pin Descriptions

Pin Name	Pin Number	Description
Prog	1	Programming voltage input, must be left open in normal operation. Maximum load = 20pF (except during programming).
VSS	2	Supply ground.
DX	3	Chip select output for 2-wire mode and Daisy Chain cascading.
CS	4	Chip select input for 3-wire mode.
C2	5	Select between 2-wire and 3-wire mode (tbd).
PWM	6	PWM output.
VDD	7	Positive supply voltage (double bond to VDD_A and VDD_D).
Test Coil	8	Test pin.
DDCLK	9	Clock input for serial interface.
DIO	10	Data I/O for serial interface.
U	11	Commutation output.
V	12	Commutation output.
W	13	Commutation output.
A	14	Incremental output.
B	15	Incremental output.
Index	16	Incremental output.
TB0/SINN	17	Test pin / inv. sin output.
TB1/SIN	18	Test pin / sin output.
TB2/COSN	19	Test pin / inv. cos output.
TB3/COS	20	Test pin / cos output.

5 Absolute Maximum Ratings

Stresses beyond those listed in [Table 2](#) may cause permanent damage to the device. These are stress ratings only, and functional operation of the device at these or any other conditions beyond those indicated in [Electrical Characteristics on page 5](#) is not implied. Exposure to absolute maximum rating conditions for extended periods may affect device reliability.

Table 2. Absolute Maximum Ratings

Parameter	Min	Max	Units	Comments
Supply voltage	-0.3	7	V	Except during OTP programming
Input Pin Voltage	VSS-0.5	VDD	V	
Input Current (latch up immunity)	-100	100	mA	Norm: EIA/JESD78 ClassII Level A
ESD	±2		kV	Norm: JESD22-A114E
Package Thermal Resistance SL		145	°C/W	Still Air / Single Layer
Package Thermal Resistance ML		90	°C/W	Still Air / Multi Layer
Storage Temperature	-55	140	°C	
Soldering conditions, Body temperature (Pb-free package)		260	°C	T=20 to 40s, Norm: IPC/JEDEC J-Std-020C. Lead finish 100%Sn "matte tin"
Humidity non-condensing	5	85	%	

6 Electrical Characteristics

T_{AMB} = -40 to 140°C, VDD5V = 4.5-5.5V, all voltages referenced to V_{SS}, unless otherwise noted.

Table 3. Electrical Characteristics

Symbol	Parameter	Conditions	Min	Typ	Max	Units
VDD	Positive Supply Voltage		4.5		+5.5	V
I _{DD}	Operating Current	No load on outputs. Supply current can be reduced by using stronger magnets.			15	mA
I _{off}	Power down current	Low Power Mode			120	μA
T _J	Junction Temperature				170	°C
System Parameters						
N	Resolution			8.5		Bit
				1		Deg
T _{PwrUp}	Power Up Time	Startup from zero			≤4100	μs
		Startup from Low/Mid Power mode			≤500	
t _s	Tracking rate	Step rate of tracking ADC; 1 step = 1°	3.0	4	5,2	μs/step
INL _{cm}	Accuracy	Centered Magnet	-2		2	
		Within horizontal displacement radius (4.4)	-3		3	Deg
t _{delay}	Propagation delay			17	22	μs
TN	Transition noise	Peak-Peak			1.41	Deg
Magnet Specifications						
MD	Magnet diameter	Diametrically magnetized		6		mm
MT	Magnet thickness			2.5		mm
B _i	Magnetic Input Range	At chip surface	20		80	
V _i	Magnet rotation speed	To maintain locked state			30.000	
B	Magnetic field low detection		<20		<36	
B	Magnetic field high detection		>44		>80	
	Hall Array radius			1		
	Vertical distance of magnet		0,5	1	1,8	
	Horizontal magnet displacement radius	Max X-Y Offset between defined IC Package center and magnet axis			0.25	mm
		Max X-Y Offset between chip center and magnet axis			0.48	
PWM Output						
N _{PWM}	PWM resolution	1 Step = 1°		8.5		Bit
				2		μs/step
PW _{MIN}	PWM pulse width	Angle = 0° (00H)		16		μs
PW _{MAX}	PWM pulse width	Angle = 360° (FFH)		736		μs
PW _P	PWM period			750		μs
f _{PWM}	PWM frequency	=1 / PWM period		1.43		kHz
Programming Parameters						

Table 3. Electrical Characteristics (Continued)

Symbol	Parameter	Conditions	Min	Typ	Max	Units
V _{PROG}	Programming Voltage	Static voltage at pin Prog	8.0		8.5	V
I _{PROG}	Programming Current				100	mA
T _{ambPROG}	Programming ambient temperature	During programming	0		85	°C
t _{PROG}	Programming time	Timing is internally generated	2		4	µs
V _{R,prog}	Analog readback voltage	During analog readback mode at pin Prog			0.5	V
V _{R,unprog}			2,2		3,5	
Hall Element Sensitivity Options						
sens	Hall Element sensitivity setting	sens = 00 (default; high sensitivity)		1.65		X
		sens = 01		1.88		
		sens = 10		2.11		
		sens = 11 (low sensitivity)		2.35		
DC Characteristics of Digital Inputs and Outputs						
CMOS Inputs: DDCLK, CS, DIO, C1, C2						
V _{IH}	High level input voltage		0.7*V _D			V
V _{IL}	Low level input voltage				0.3	V
I _{LEAK}	Input leakage current				1	µA
CMOS Outputs: DIO, PWM, DX						
V _{OH}	High level output voltage	Source current < 4mA	V _{DD} -0.5			V
V _{OL}	Low level output voltage	Sink current < 4mA			V _{SS} +0.4	V
CL	Capacitive load				35	pF
CMOS Tristate Output: DIO						
I _{OZ}	Tristate leakage current	CS = low			1	µA

Timing Characteristics

Table 4. Timing Characteristics

Symbol	Parameter	Conditions	Min	Typ	Max	Units
2-/3-Wire Data Transmission						
3-Wire Interface						
f _{DCLK}	Clock Frequency	Normal operation	No limit	5	6	MHz
f _{DCLK,P}	Clock Frequency	During OTP programming	200		650	kHz
2-Wire Interface						
f _{DCLK}	Clock Frequency	Normal operation	0.1	5	6	MHz
f _{DCLK,P}	Clock Frequency	During OTP programming	200		500	kHz
General Data Transmission						
t ₀	Rising DCLK to CS		15		-	ns
t ₁	Chip select to positive edge of DCLK		15		-	ns
t ₂	Chip select to drive bus externally		-		-	ns
t ₃	Setup time command bit, Data valid to positive edge of DCLK		30		-	ns
t ₄	Hold time command bit, Data valid after positive edge of DCLK		30			ns
t ₅	Float time, Positive edge of DCLK for last command bit to bus float		30		DCLK/2	ns
t ₆	Bus driving time, Positive edge of DCLK for last command bit to bus drive		DCLK/2 +0		DCLK/2 +30	ns
t ₇	Setup time data bit, Data valid to positive edge of DCLK		DCLK/2 +0		DCLK/2 +30	ns
t ₈	Hold time data bit, Data valid after positive edge of DCLK		DCLK/2 +0		DCLK/2 +30	ns
t ₉	Hold time chip select, Positive edge DCLK to negative edge of chip select		30			ns
t ₁₀	Bus floating time, Negative edge of chip select to float bus		0		30	ns
t _{TO}	Timeout period in 2-wire mode (from rising edge of DCLK)		20		24	µs

7 Detailed Description

Connecting the AS5134

The AS5134 can be connected to an external controller in several ways as listed below:

- Serial 3-wire R/W connection
- Serial 3-wire Read-only connection
- Serial 2-Wire connection (R/W Mode)
- Serial 2-Wire Differential SSI connection
- 1-Wire PWM connection
- Analog output
- Analog Sin/Cos outputs with external interpolator
- Quadrature A/B/Index output
- Brushless DC Motor Commutation Mode

Serial 3-Wire R/W Connection

In this mode, the AS5134 is connected to the external controller via three signals: Chip Select (CS), Clock (DCLK) inputs and bi-directional DIO (Data In/Out) output. The controller sends commands over the DIO pin at the beginning of each data transmission sequence, such as reading the angle or putting the AS5134 in and out of the reduced power modes.

Figure 3. SSI Read/Write Serial Data Transmission

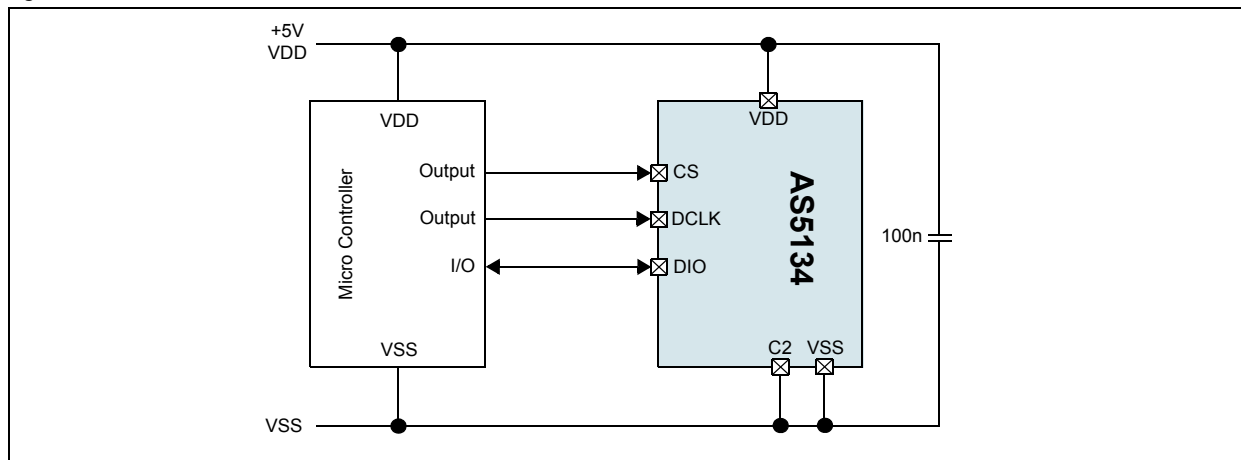

A pull-down resistor (as shown in [Figure 4](#)) is not required. C1 and C2 are hardware configuration inputs. C1 must always be connected to VSS, C2 selects 3-wire mode (C2 = low) or 2-wire mode (C2 = high).

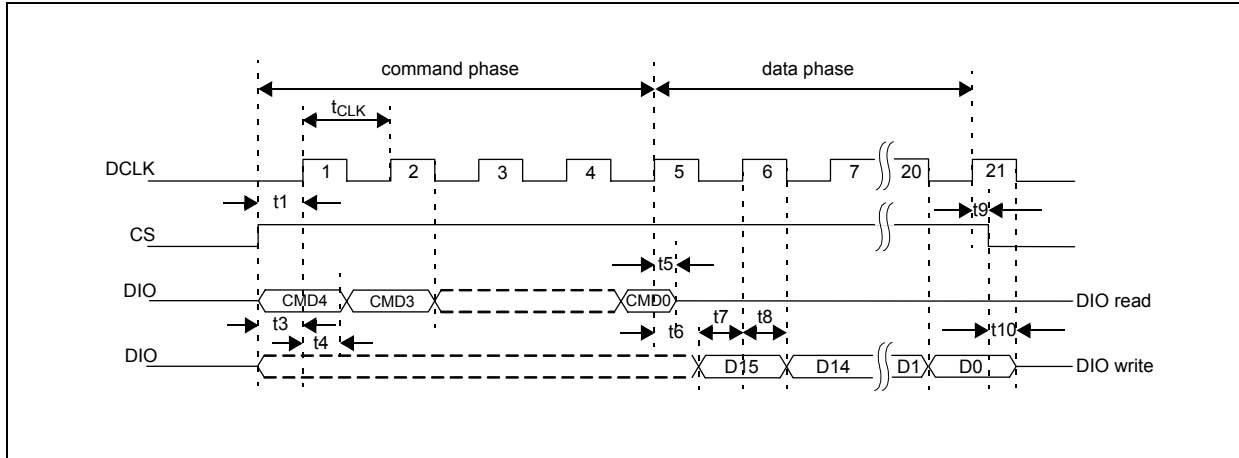

Table 5. Serial Bit Sequence (16bit read/write)

Write Command					Read/Write Data															
C4	C3	C2	C1	C0	D15	D14	D13	D12	D11	D10	D9	D8	D7	D6	D5	D4	D3	D2	D1	D0

Serial 3-Wire Read-only Connection

This simplified connection is possible when the AS5134 is only used to provide the angular data (no power down or OTP access). The Chip Select (CS) and Clock (DCLK) connection is the same as in the R/W mode, but only a digital input pin (not an I/O pin) is required for the DIO connection. As the first 5 bits of the data transmission are command bits sent to the AS5134, both the microcontroller and the AS5134 are configured as digital inputs during this phase. Therefore, a pull-down resistor must be added to make sure that the AS5134 reads “00000” as the first 5 bits, which sets the Read_Angle command.

Note: All further application examples are shown in R/W mode, however read-only mode is also possible unless otherwise noted.

Figure 4. SSI Read-only Serial Data Transmission

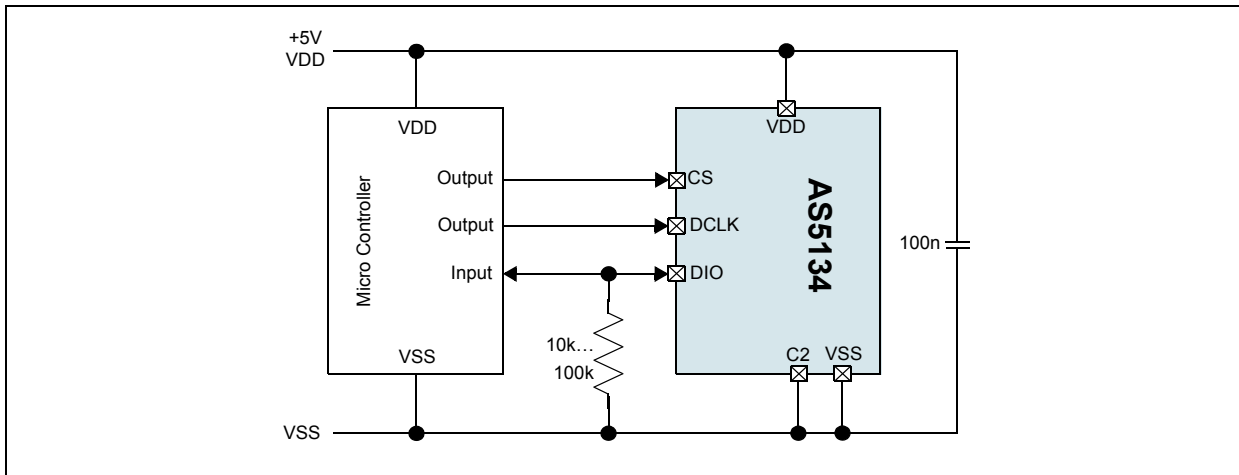

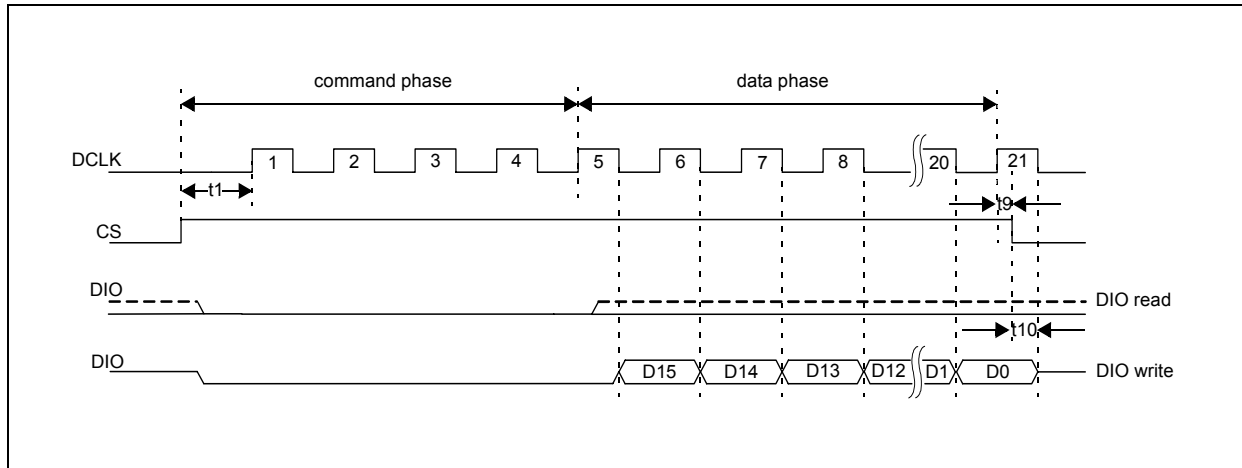

Table 6. 2-or 3-wire Read-only Serial Bit Sequence (21bit read)

Read																				
D20	D19	D18	D17	D16	D15	D14	D13	D12	D11	D10	D9	D8	D7	D6	D5	D4	D3	D2	D1	D0
0	0	0	0	0	C2	lock	AGC					Angle								
							D5	D4	D3	D2	D1	D0	D7	D6	D5	D4	D3	D2	D1	D0

Serial 2-Wire Connection (R/W Mode)

By connecting the configuration input C2 to VDD, the AS5134 is configured to 2-wire data transmission mode. Only Clock (DCLK) and Data (DIO) signals are required. A Chip Select (CS) signal is automatically generated by the DX output, when a time-out of DCLK occurs (typ. 20µs).

Note: Read-only mode is also possible in this configuration.

Figure 5. 2-Wire R/W Mode

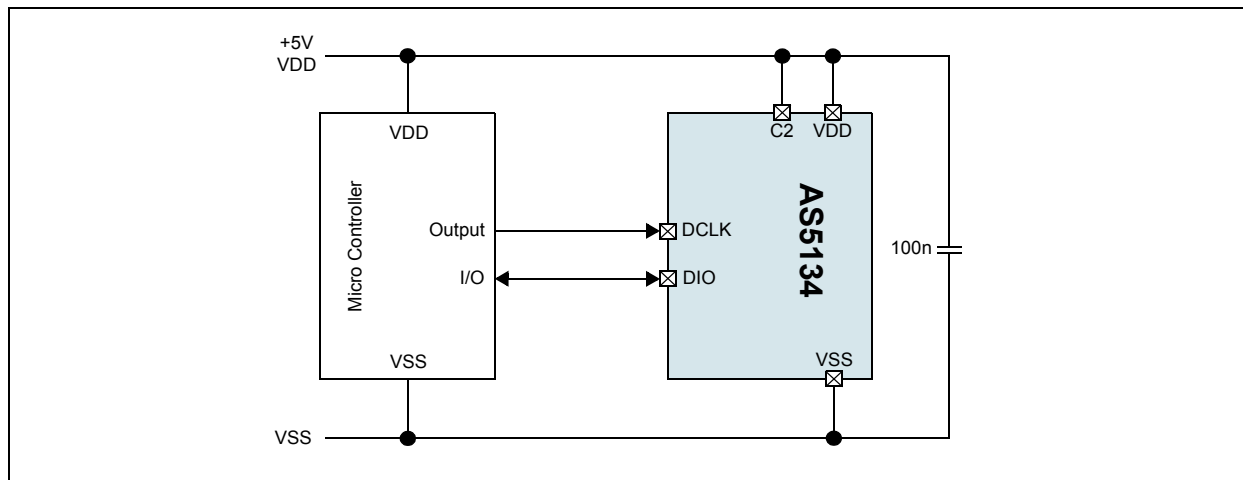

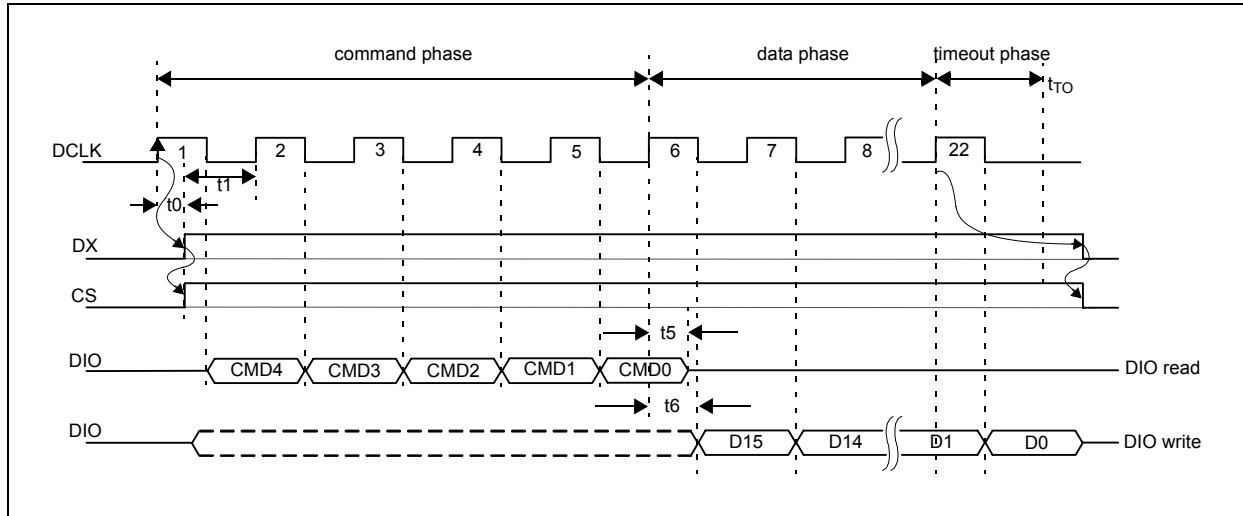

Serial 2-Wire Differential SSI Connection

With the addition of a RS-422 / RS-485 transceiver, a fully differential data transmission, according to the 21-bit SSI interface standard is possible. To be compatible with this standard, the DCLK signal must be inverted. This is done by reversing the Data+ and Data- lines of the transceiver.

Note: This type of transmission is read-only.

Figure 6. 2-Wire SSI Read-only Mode

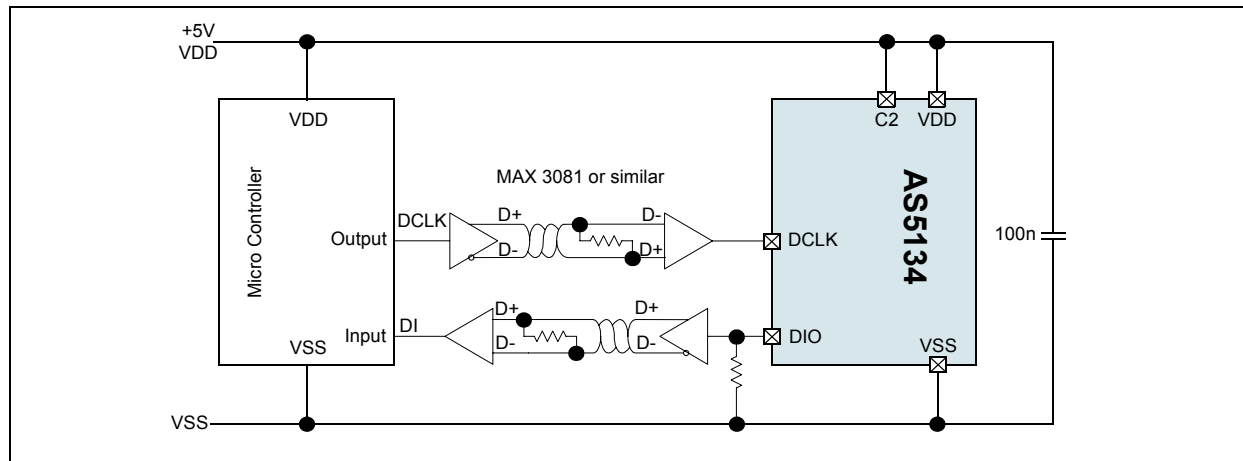

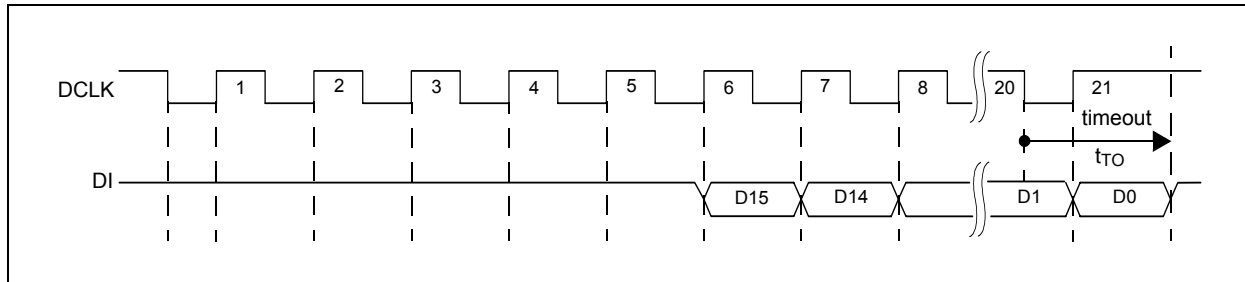

Read																				
D20	D19	D18	D17	D16	D15	D14	D13	D12	D11	D10	D9	D8	D7	D6	D5	D4	D3	D2	D1	D0
0	0	0	0	0	C2	lock	AGC					Angle								
							D5	D4	D3	D2	D1	D0	D7	D6	D5	D4	D3	D2	D1	D0

1-Wire PWM Connection

This configuration uses the least number of wires: only one line (PWM) is used for data, leaving the total number of connection to three, including the supply lines. This type of configuration is especially useful for remote sensors. Ultra Low Power Mode is not possible in this configuration, as there is no bi-directional data transmission. If the AS5134 angular data is invalid, the PWM output will remain at low state. Pins that are not shown may be left open.

Figure 7. Data Transmission with Pulse Width Modulated (PWM) Output

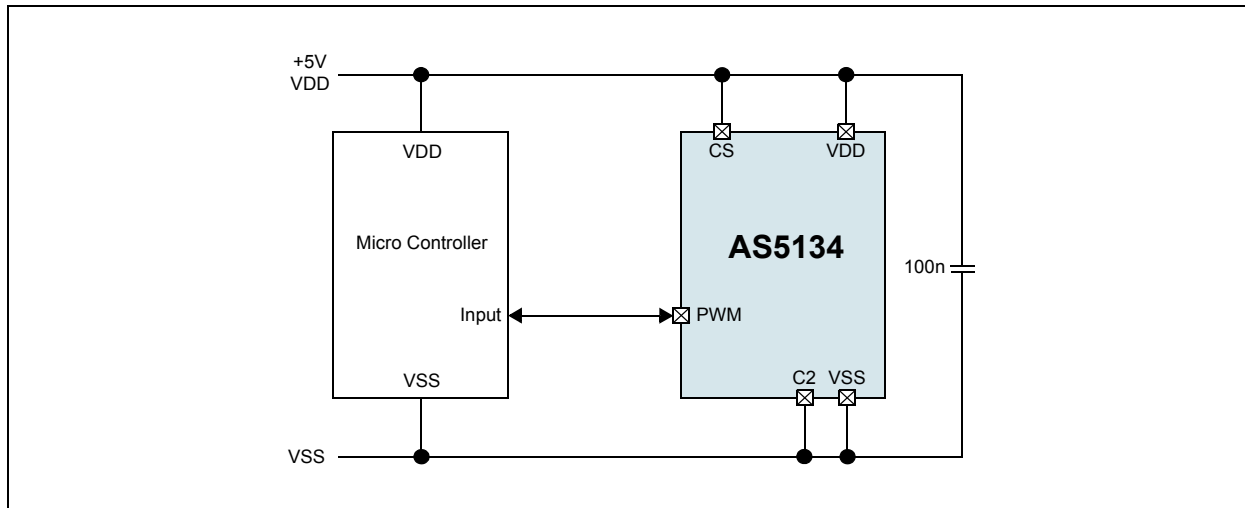

Analog Output

This configuration is similar to the PWM connection (only three lines including supply are required). With the addition of a lowpass filter at the PWM output, this configuration produces an analog voltage that is proportional to the angle. This filter can be either passive (as shown in Figure 8) or active. The lower the bandwidth of the filter, the less ripple of the analog output can be achieved. If the AS5134 angular data is invalid, the PWM output will remain at low state and thus the analog output will be 0V. Pins that are not shown may be left open.

Figure 8. Data Transmission with Pulse Width Modulated (PWM) Output

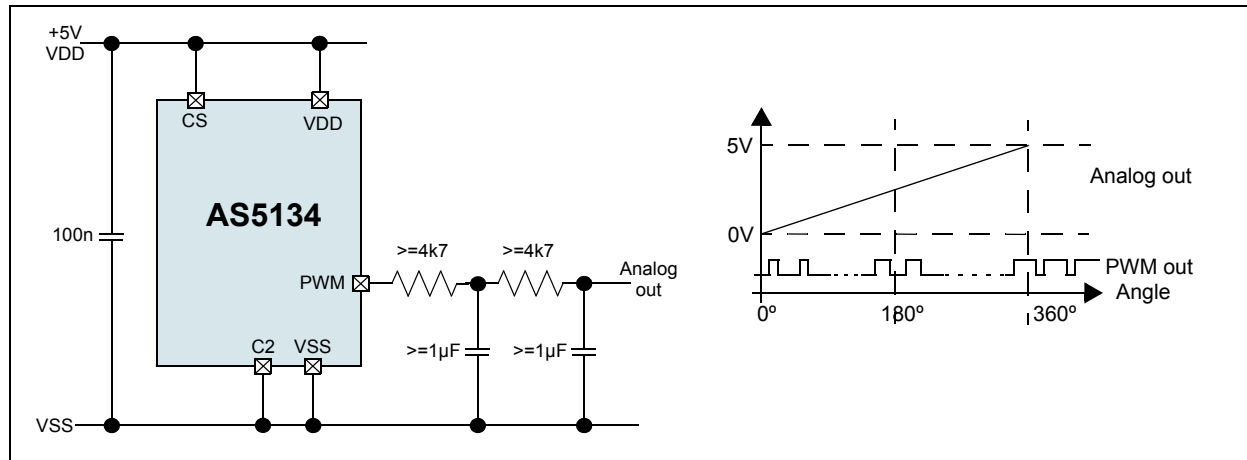

Analog Sin/Cos Outputs with External Interpolator

By connecting C1 to VDD, the AS5134 provides analog Sine and Cosine outputs (Sin, Cos) of the Hall array front-end for test purposes. These outputs allow the user to perform the angle calculation by an external ADC + μC , e.g. to compute the angle with a high resolution. In addition, the inverted Sine and Cosine signals (SINN, COSN; see dotted lines) are available for differential signal transmission.

The input resistance of the receiving amplifier or ADC should be greater than $100\text{k}\Omega$. The signal lines should be kept as short as possible, longer lines should be shielded in order to achieve best noise performance.

The SIN / COS / SINN / COSN signals are amplitude controlled to $\sim 1.3\text{Vpp}$ (differential) by the internal AGC controller. The DC bias voltage is $\sim 2.25\text{V}$.

Note: These outputs are high impedance and not resilient, (Load max. $10\mu\text{A}$).

Figure 9. Sine and Cosine Outputs for External Angle Calculation

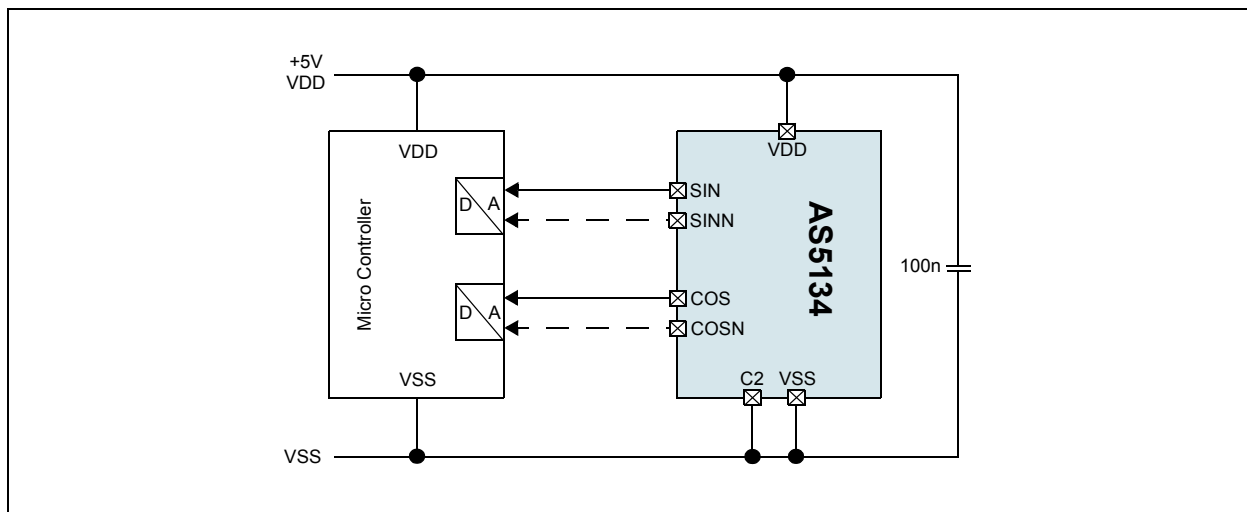

Quadrature A/B/Index Output

The phase shift between channel A and B indicates the direction of the magnet movement. Channel A leads channel B at a clockwise rotation of the magnet (top view) by 90 electrical degrees. Channel B leads channel A at a counter-clockwise rotation.

Figure 10. Incremental Output Modes

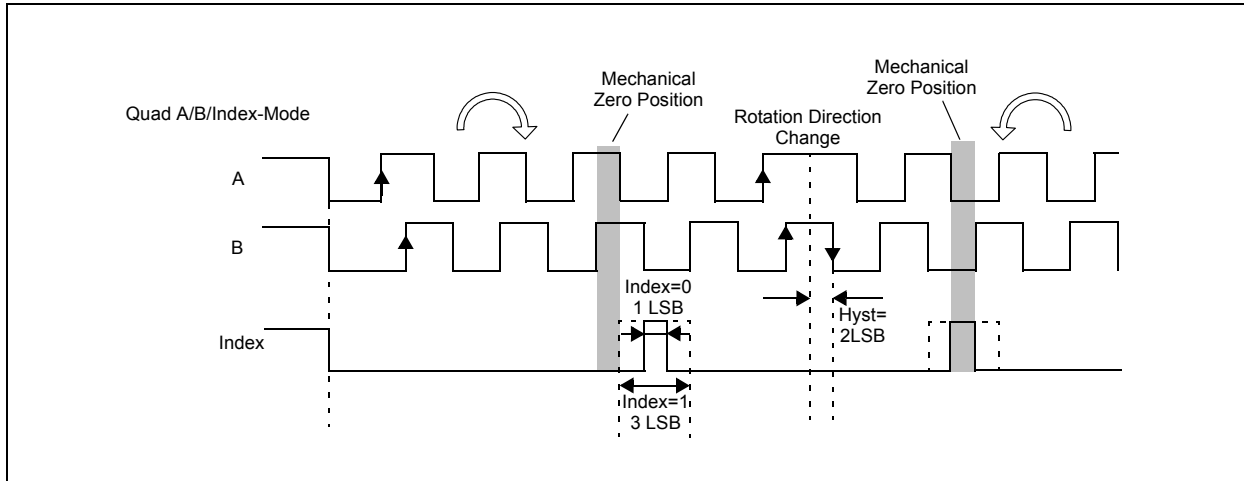

Brushless DC Motor Commutation Mode

The BLDC signals will be used to control the electrical angle information – according to the amount of pole pairs and the actual mechanical angle position. Refer [Figure 11](#) for an example of $n_{pole_pairs}=2$. For the programming, refer to [Serial Synchronous Interface \(SSI\)](#) on page 15.

Figure 11. Commutation Mode

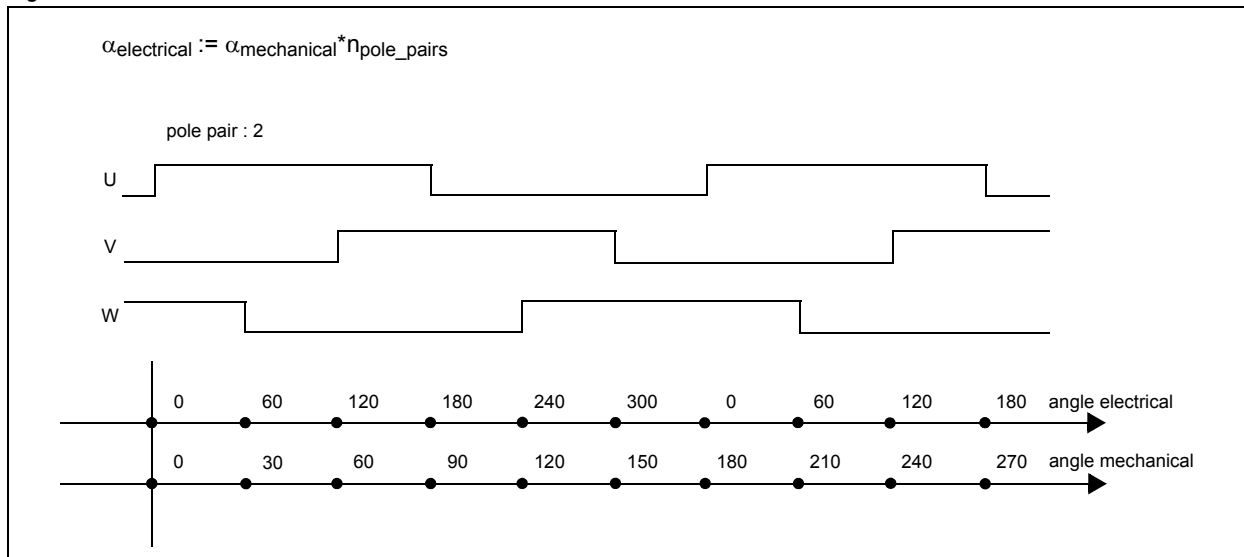

Serial Synchronous Interface (SSI)

Table 7. Commands of the SSI in Normal Mode

Digital interface @ normal mode																						
#	cmd	bin	mode	15	14	13	12	11	10	9	8	7	6	5	4	3	2	1	0			
23	WRITE CONFIG 1	10111	write	LP	gen_rst	MTC2 (*)	MTC1 (*)	Hyst<1:0>		analog Sig	AGC_mux	AGC2 PWM										
20	SET MT COUNTER	10100	write	multi-turn-counter <8:0>																		
19	SET AGC	10011	write	agc_code <2:0>				agc_tst_value <5:0>														
16	EN PROG	10000	write	1	0	0	0	1	1	0	0	1	0	1	0	1	1	1	0			
4	RD MT COUNTER	00100	read	multi-turn-counter <8:0>												ez_error						
0	RD_ANGLE	00000	read	lock_adc	agc <5:0>						angle <8:0>											

Table 8. Commands of the SSI in Extended Mode

Digital interface @ extended mode																				
number of bits				2	18	1	1	4	2	1	4	2	3	1	4	1	2	2	3	9
#	cmd	bin	mode	61..60	59..42	41	40	39..36	35..32	31	30..27	26..25	24..22	21	20..17	16	15..14	13..12	11..9	8..0
31	WRITE OTP	11111	xt write	otp tst	ID	hyst_2x	cfg	off_cos	off_sin	FM	osc	vref	Hall Bias	lock_otp (*)	r_ad_d	r_bit	sensitivity	abi	uvw	zero angle
25	PROG_OTP	11001	xt write	otp tst	ID	hyst_2x	LP	osc	vref	LP	osc	vref	Hall Bias	lock_otp (*)	r_ad_d	r_bit	sensitivity	abi	uvw	zero angle
15	READ_OTP	01111	xt read	otp tst	ID	hyst_2x	LP	osc	vref	LP	osc	vref	Hall Bias	lock_otp (*)	r_ad_d	r_bit	sensitivity	abi	uvw	zero angle
9	READ ANA	01001	xt read	otp tst	ID	hyst_2x	LP	osc	vref	LP	osc	vref	Hall Bias	lock_otp (*)	r_ad_d	r_bit	sensitivity	abi	uvw	zero angle

Notes:

1. Empty fields should be described with "logical 0".
2. The lock_adc signal indicates that the tracking adc is in a locked status – remark, that for valid angle conditions the magnetic field has to be in a certain range which is indicated by the agc_counter value.
3. These bits will be deleted during power down or sleep mode to ensure that the user is able to detect that the read out angle value is computed after the wake up sequence.

EN PROG: Enables the access to the OTP register.

WRITE CONFIG: go2sleep HI activates the sleep mode of the AS5134. The power consumption is significantly reduced. go2sleep LO returns to normal operation mode. During sleep mode, the lock bit in command 0 and command 1 is LO.

RD_MT Counter: Command for read out of multi turn register (multiturn) and AGC value (agc). "Lock" indicates a locked ADC, and "parity" refers to an even parity checksum.

RD_ANGLE: Command for read out of angle value and AGC value (agc). "Lock" indicates a locked ADC, and "parity" refers to an even parity checksum.

WRITE OTP: Writing of the OTP register. The written data is volatile. "Zero Angle" is the angle, which is set for zero position. "Wake enable" enables the polling mode. "Sensitivity" is the gain setting in the signal path. "Redundancy" is the number of bits, which allows the customer to overwrite one of the customer OTP bits <0:11>.

PROG_OTP: Programming of the OTP register. Only Bits <0:15> can be programmed by the customer.

READ_OTP: Read out the content of the OTP register. Data written by WRITE_OTP and PROG_OTP is read out.

READ ANA: Analog read out mode. The analog value of every OTP bit is available at pin 2 (PROG), which allows for a verification of the fuse process. No data is available at the SSI.

AS5134 Programming

The AS5134 offers the following user programmable options:

- **Zero Position Programming**

This programming option allows the user to program any rotation angle of the magnet as the new zero position. This useful feature simplifies the assembly process as the magnet does not need to be mechanically adjusted to the electrical zero position. It can be assembled in any rotation angle and later matched to the mechanical zero position by zero position programming. The 8,5-bit user programmable zero position can be applied both temporarily (command WRITE OTP, #31) or permanently (command PROG OTP, #25).

- **Magnetic Field Optimization**

This programming option allows the user to match the vertical distance of the magnet with the optimum magnetic field range of the AS5134 by setting the sensitivity level. The 2-bit user programmable sensitivity setting can be applied both temporarily (command WRITE OTP, #31) or permanently (command PROG OTP, #25).

- **Low/Mid Power Mode**

Mid Power Mode is a power saving mode with fast start-up. In Mid Power Mode, all internal digital registers are frozen and the power consumption is reduced to max. 1,5 mA. Start-up from this mode to normal operation can be accomplished within 250µs. This mode is recommended for applications, where mid power, but fast start-up and short reading cycle intervals are required.

OTP Programming Connection

Programming of the AS5134 OTP memory does not require a dedicated programming hardware. The programming can be simply accomplished over the serial 3-wire interface (see Figure 12) or the optional 2-wire interface (see Figure 5). For permanent programming (command PROG OTP, #25), a constant DC voltage of 8.0 – 8.5V (=100mA) must be connected to pin 1 (PROG). For temporary OTP write (“soft write”; command WRITE OTP, #31), the programming voltage is not required.

Figure 12. OTP Programming Connection

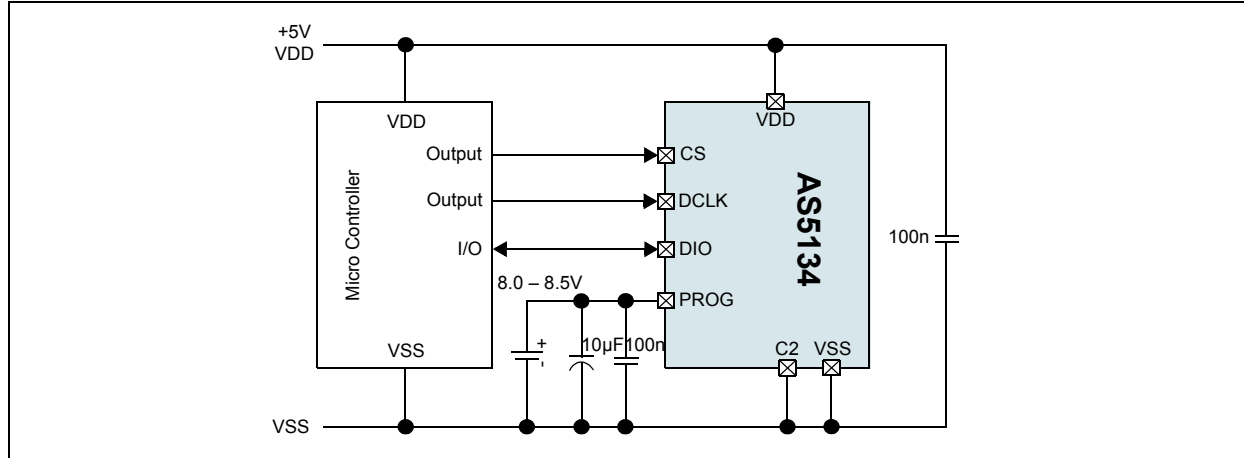

Programming Verification

After programming, the programmed OTP bits may be verified in two ways:

By Digital Verification: This is simply done by sending a READ OTP command (#15). The structure of this register is the same as for the OTP PROG or OTP WRITE commands.

By Analog Verification: By sending an ANALOG OTP READ command (#9), pin PROG becomes an output, sending an analog voltage with each clock, representing a sequence of the bits in the OTP register. A voltage of <500mV indicates a correctly programmed bit (“1”) while a voltage level between 2.2V and 3.5V indicates a correctly unprogrammed bit (“0”). Any voltage level in between indicates improper programming.

Figure 13. Analog OTP Verification

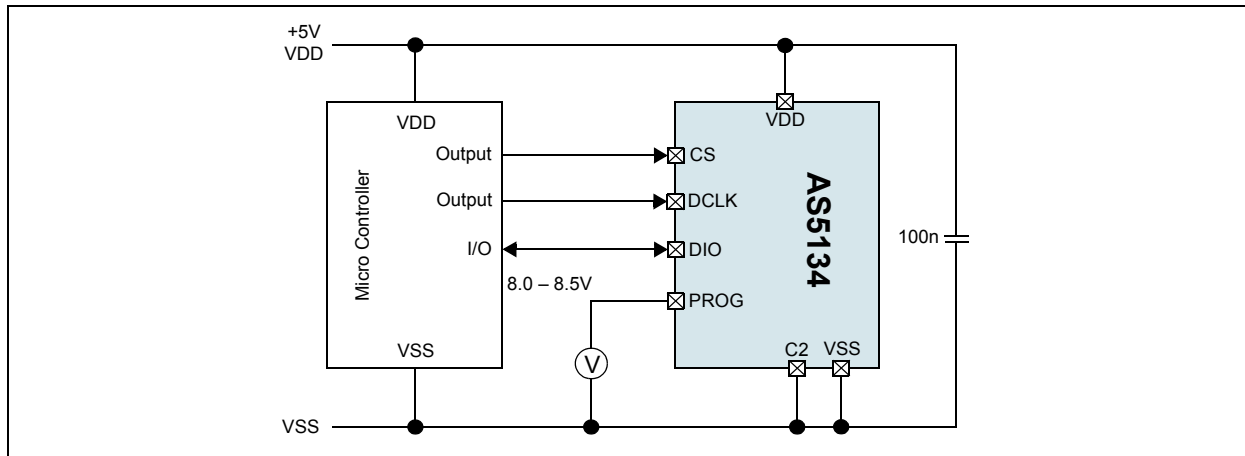
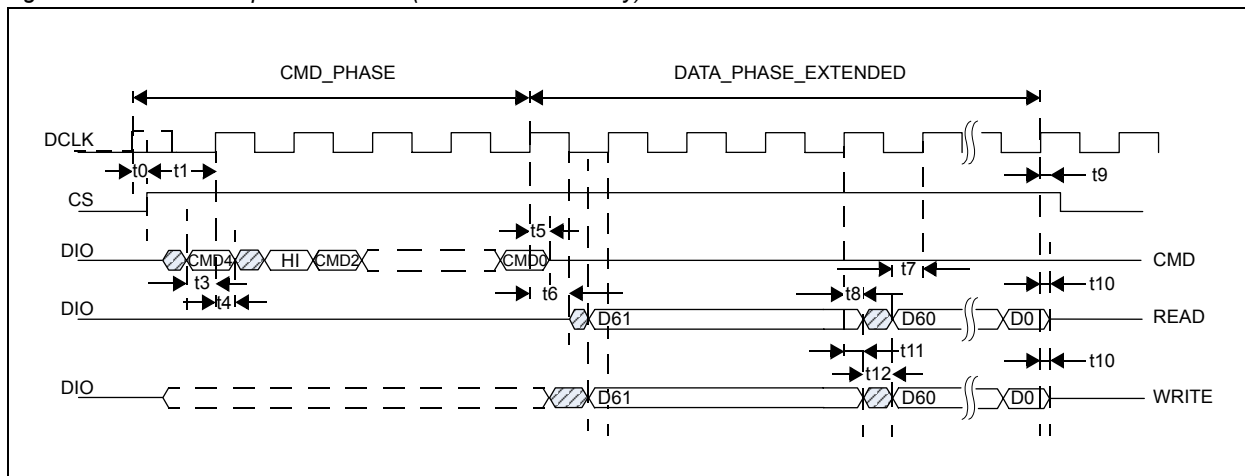

Figure 14. Extended Operation Mode (for OTP access only)



AS5134 Status Indicators

C2 Status Bit

This bit represents the hardware connection of the C2 configuration pin (#15) to determine, which hardware configuration is selected for the AS5134 in question.

- C2 = low: Pin C2 is low, indicating that the AS5134 is in 3-wire mode
- C2 = high: Pin C2 is high, indicating that the AS5134 is in 2-wire

Lock Status Bit

The Lock signal indicates, whether the angle information is valid (ADC locked, Lock = high) or invalid (ADC unlocked, Lock = low). To determine a valid angular signal at best performance, the following indicators should be set:

Lock = 1

AGC = >00H and < 2FH

Note: The angle signal may also be valid (Lock = 1), when the AGC is out of range (00H or 2FH), but the accuracy of the AS5134 may be reduced due to the out of range condition of the magnetic field strength.

Magnetic Field Strength Indicators

The AS5134 is not only able to sense the angle of a rotating magnet, it can also measure the magnetic field strength (and hence the vertical distance) of the magnet. This additional feature can be used for several purposes:

- as a safety feature by constantly monitoring the presence and proper vertical distance of the magnet
- as a state-of-health indicator, e.g. for a power-up self test
- as a pushbutton feature for rotate-and-push types of manual input devices

The magnetic field strength information is available in two forms:

Magnetic Field Strength Software Indicator

The serial data that is obtained by command READ ANGLE contains the 6-bit AGC information. The AGC is an automatic gain control that adjusts the internal signal amplitude obtained from the Hall elements to a constant level. If the magnetic field is weak, e.g. with a large vertical gap between magnet and IC, with a weak magnet or at elevated temperatures of the magnet, the AGC value will be high. Likewise, the AGC value will be lower when the magnet is closer to the IC, when strong magnets are used and at low temperatures.

The best performance of the AS5134 will be achieved when operating within the AGC range. It will still be operational outside the AGC range, but with reduced performance especially with a weak magnetic field due to increased noise.

Factors Influencing the AGC Value

In practical use, the AGC value will depend on several factors:

- **The initial strength of the magnet.** Aging magnets may show a reducing magnetic field over time which results in an increase of the AGC value. The effect of this phenomenon is relatively small and can easily be compensated by the AGC.
- **The vertical distance of the magnet.** Depending on the mechanical setup and assembly tolerances, there will always be some variation of the vertical distance between magnet and IC over the lifetime of the application using the AS5134. Again, vertical distance variations can be compensated by the AGC.
- **The temperature and material of the magnet.** The recommended magnet for the AS5134 is a diametrically magnetized, 5-6mm diameter NdFeB (Neodymium-Iron-Boron) magnet. Other magnets may also be used as long as they can maintain to operate the AS5134 within the AGC range. Every magnet has a temperature dependence of the magnetic field strength. The temperature coefficient of a magnet depends on the used material. At elevated temperatures, the magnetic field strength of a magnet is reduced, resulting in an increase of the AGC value. At low temperatures, the magnetic field strength is increased, resulting in a decrease of the AGC value. The variation of magnetic field strength over temperature is automatically compensated by the AGC.

OTP Sensitivity Adjustment

To obtain best performance and tolerance against temperature or vertical distance fluctuations, the AGC value at normal operating temperature should be in the middle between minimum and maximum, hence it should be around 100000 (20H). To facilitate the "vertical centering" of the magnet+IC assembly, the sensitivity of the AS5134 can be adjusted in the OTP register in 4 steps. A sensitivity adjustment is recommended, when the AGC value at normal operation is close to its lower limit (around 00H). The default sensitivity setting is 00H = high sensitivity. Any value >00H will reduce the sensitivity.

Multi Turn Counter

A 9-bit register is used for counting the magnet's revolutions. With each zero transition in any direction, the output of a special counter is incremented or decremented. The initial value after reset is 0 LSB. The multi turn value is encoded as complement on two. Clockwise rotation gives increasing angle values and positive turn count. Counter clockwise rotation exhibits decreasing angle values and a negative turn count respectively.

Bit Code	Decimal Value
01111111	256
---	---
01111111	127
---	---
00000011	+3

Bit Code	Decimal Value
00000010	+2
00000001	+1
00000000	0
11111111	-1
11111110	-2
11111101	-3
---	---
10000000	-128
---	---
100000000	-255

The counter output can be reset by using command 20 – SET MT Counter. It is immediately reset by the rising clock edge of this bit. Any zero crossing between the clock edge and the next counter readout changes the counter value.

High Speed Operation

The AS5134 is using a fast tracking ADC (TADC) to determine the angle of the magnet. The TADC is tracking the angle of the magnet with cycle time of 4µs. Once the TADC is synchronized with the angle, it sets the LOCK bit in the status register. In worst case, usually at start-up, the TADC requires up to 255 steps (255 * 4µs = 1020µs) to lock. Once it is locked, it requires only one cycle (4µs) to track the moving magnet. The AS5134 can operate in locked mode at rotational speeds up to min. 30,000 rpm.

In Low/Mid Power Mode, the position of the TADC is frozen. It will continue from the frozen position once it is powered up again. If the magnet has moved during the power down phase, several cycles will be required before the TADC is locked again. The tracking time to lock in with the new magnet angle can be roughly calculated as:

$$t_{LOCK} = \frac{4\mu s * |NewAngle - OldAngle|}{1.406} \quad (EQ 1)$$

Where:

t_{LOCK} = Time required to acquire the new angle after power up from one of the reduced power modes [µs]

OldAngle = Angle position when one of the reduced power modes is activated [°]

NewAngle = Angle position after resuming from reduced power mode [°]

Propagation Delay

The Propagation delay is the time required from reading the magnetic field by the Hall sensors to calculating the angle and making it available on the serial or PWM interface. While the propagation delay is usually negligible on low speeds, it is an important parameter at high speeds. The longer the propagation delay, the larger becomes the angle error for a rotating magnet as the magnet is moving while the angle is calculated. The position error increases linearly with speed. The main factors that contribute to the propagation delay are discussed in detail further in this document.

ADC Sampling Rate

For high speed applications, fast ADC's are essential. The ADC sampling rate directly influences the propagation delay. The fast tracking ADC used in the AS5134 with a tracking rate of only 1.4 µs (typ) is a perfect fit for both high speed and high performance.

Chip Internal Lowpass Filtering

A commonplace practice for systems using analog-to-digital converters is to filter the input signal by an anti-aliasing filter. The filter characteristic must be chosen carefully to balance propagation delay and noise. The lowpass filter in the AS5134 has a cutoff frequency of typ. 23.8kHz and the overall propagation delay in the analog signal path is typ. 15.6µs.

Digital Readout Rate

Aside from the chip-internal propagation delay, the time required to read and process the angle data must also be considered. Due to its nature, a PWM signal is not very usable at high speeds, as you get only one reading per PWM period. Increasing the PWM frequency may improve the situation but causes problems for the receiving controller to resolve the PWM steps. The frequency on the AS5134 PWM output is typ. 1.95kHz with a resolution of 2µs/step. A more suitable approach for high speed absolute angle measurement is using the serial interface. With a clock rate of up to 6MHz, a complete set of data (21bits) can be read in >3.5µs.

Total Propagation Delay of the AS5134

The total propagation delay of the AS5134 is the delay in the analog signal path and the tracking rate of the ADC:

$$15.6\mu\text{s} + 1.4\mu\text{s} = 17\mu\text{s} \quad (\text{EQ 2})$$

If only the SIN-/COS-outputs are used, the propagation delay is the analog signal path delay only (typ. 15.6µs).

Position Error Over Speed:

The angle error over speed caused by the propagation delay is calculated as:

$$\Delta\theta_{pd} = \text{rpm} * 6 * 17 * E^{-6} \text{ in degrees} \quad (\text{EQ 3})$$

In addition, the anti-aliasing filter causes an angle error calculated as:

$$\Delta\theta_{pf} = \text{ArcTan} [\text{rpm} / (60 * f_0)] \quad (\text{EQ 4})$$

Table 9. Examples of the Overall Position Error caused by Speed (includes both propagation delay and filter delay)

Speed (rpm)	Total Position Error ($\Delta\theta_{pd} + \Delta\theta_{pf}$)
100	0,0175°
1000	0,175°
10000	1,75°

Reduced Power Modes

The AS5134 can be operated in two reduced power modes. Both these modes have in common that they switch off or freeze parts of the chip during intervals between measurements. In Low Power Mode or Ultra Low Power Mode, the AS5134 is not operational, but due to the fast start-up, an angle measurement can be accomplished very quickly and the chip can be switched to reduced power immediately after a valid measurement has been taken. Depending on the intervals between measurements, very low average power consumption can be achieved using such a strobed measurement mode.

- Low/Mid Power Mode: Reduced current consumption, very fast start-up. Ideal for short sampling intervals (<3ms).
- Power Cycling mode: Zero power consumption (externally switched off) during sampling intervals. Ideal for sampling intervals 200ms.

Low/Mid Power Mode

The AS5134 can be put in Low/Mid Power Mode by simple serial commands, using the regular connection for 2-wire or 3-wire serial data transmission.

Figure 15. Low/Mid Power Mode Connection

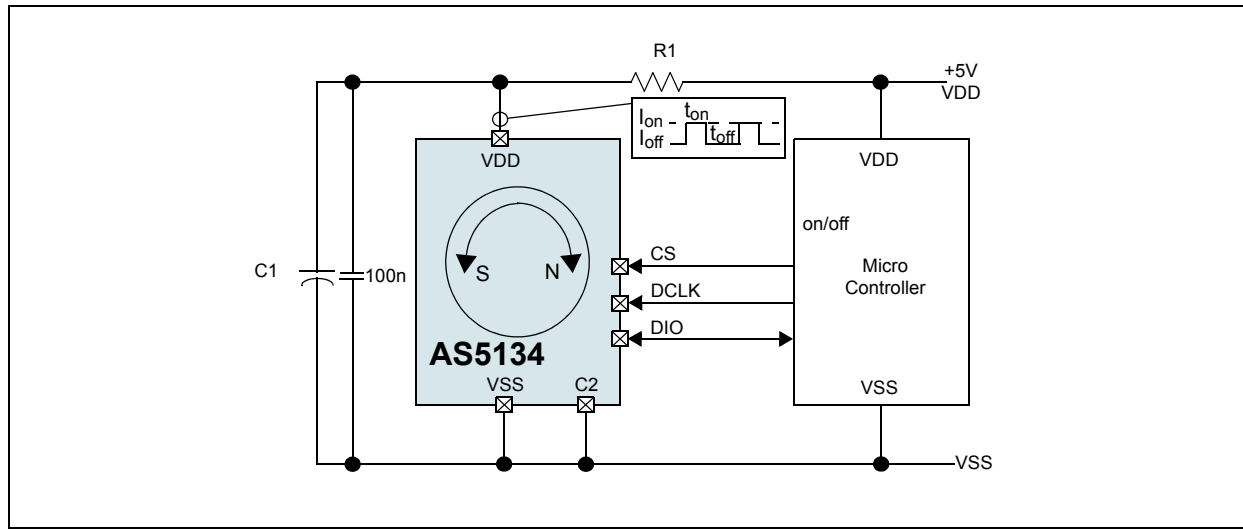

In Low/Mid Power Mode, the AS5134 is inactive. The last state, e.g. the angle, AGC value, etc. is frozen and the chip starts from this frozen state when it resumes active operation. This method provides much faster start-up than a “cold start” from zero. If the AS5134 is cycled between active and reduced current mode, a substantial reduction of the average supply current can be achieved. The minimum dwelling time is <0.5 ms. The actual active time depends on how much the magnet has moved while the AS5134 was in reduced power mode. The angle data is valid, when the status bit LOCK has been set. Once a valid angle has been measured, the AS5134 can be put back to reduced power mode. The average power consumption can be calculated as:

$$I_{avg} = \frac{I_{active} * t_{on} + I_{powerdown} * t_{off}}{t_{on} + t_{off}} \quad \text{sampling interval} = t_{on} + t_{off} \quad (EQ 5)$$

Where:

I_{avg} = Average current consumption

I_{active} = Current consumption in active mode

I_{power_down} = Current consumption in reduced power mode

t_{on} = Time period during which the chip is operated in active mode

t_{off} = Time period during which the chip is in reduced power mode

Reducing Power Supply Peak Currents

An optional RC-filter (R1/C1) may be added to avoid peak currents in the power supply line when the AS5134 is toggled between active and reduced power mode. R1 must be chosen such that it can maintain a VDD voltage of 4.5 – 5.5V under all conditions, especially during long active periods when the charge on C1 has expired. C1 should be chosen such that it can support peak currents during the active operation period. For long active periods, C1 should be large and R1 should be small.

Power Cycling Mode

The power cycling method shown in Figure 16 cycles the AS5134 by switching it on and off, using an external PNP transistor high side switch. This mode provides the least power consumption of all three modes; when the sampling interval is more than 400ms, as the current consumption in off-mode is zero. It also has the longest start-up time of all modes, as the chip must always perform a “cold start” from zero, which takes about 1.3 ms. The optional filter R1/C1 may again be added to reduce peak currents in the 5V power supply line.

Figure 16. Application Example III: Ultra-low Power Encoder

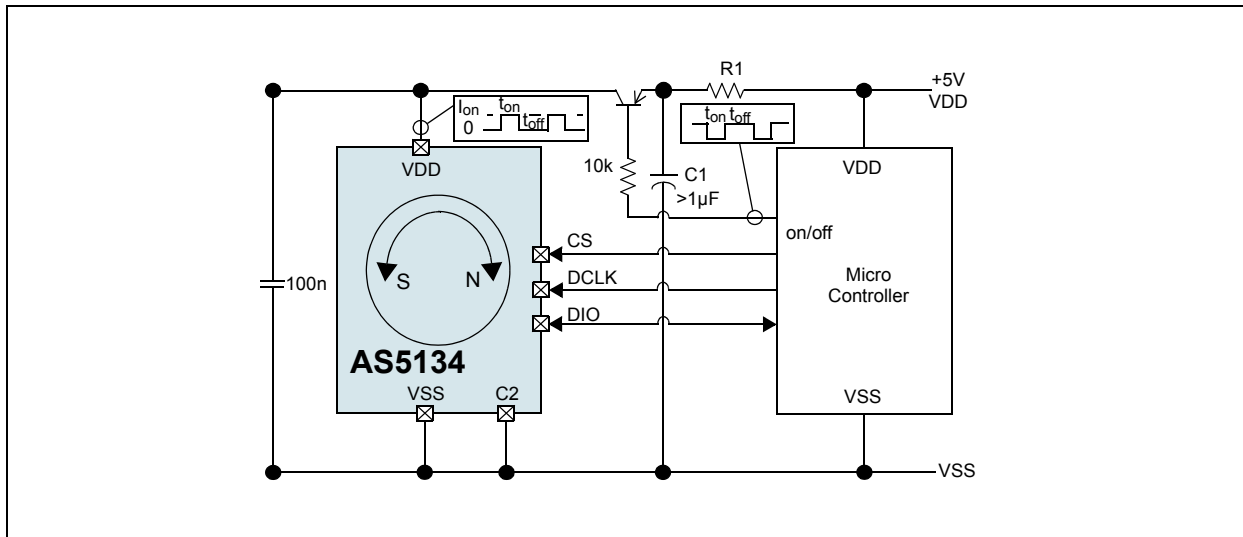

8 Application Information

Benefits of AS5134

- Complete system-on-chip, no angle calibration required
- Flexible system solution provides absolute serial, ABI, UVW and PWM outputs
- Ideal for applications in harsh environments due to magnetic sensing principle
- High reliability due to non-contact sensing
- Robust system, tolerant to horizontal misalignment, airgap variations, temperature variations and external magnetic fields

Figure 17. Typical Arrangement of AS5134 and Magnet

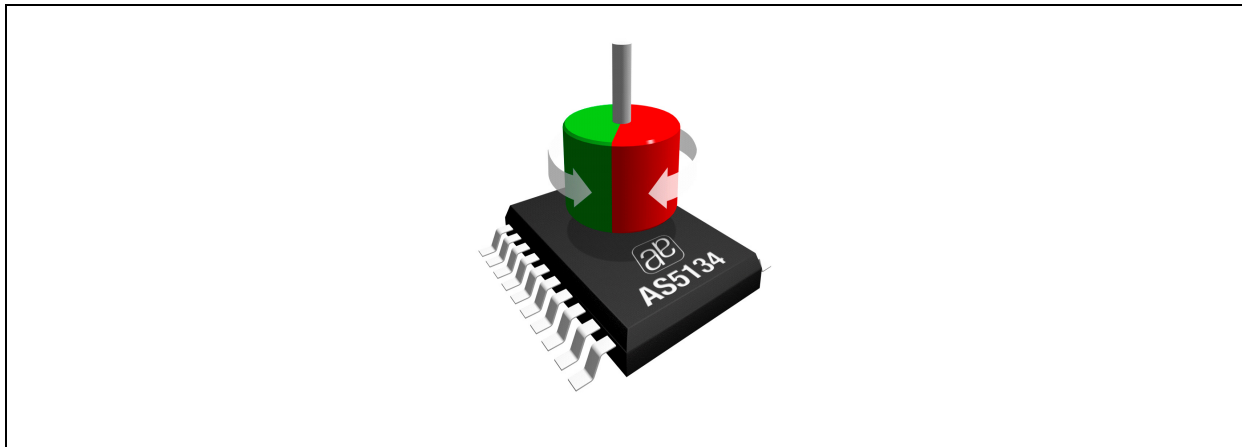

AS5134 Parameter and Features List

Table 10. Parameter and Features List

Parameter	AS5134
Supply Voltage	4.5 to 5.5 V
Resolution	8.5 bit (360 steps, 1° per step)
Incremental outputs (ABI)	ABI quadrature: 90 ppr, (default) step/direction: 180 ppr (OTP option) fixed pulse width: 360ppr (tbd)
BLDC outputs	UVW ; selectable for 1,2,3,4,5,6, pole pairs
Absolute output	Serial 2-wire (DCLK,DIO) with timeout sync Serial 3-wire (DCLK, CS, DIO) PWM output
Daisy Chain mode	Available for 2-wire and 3-wire serial modes
Automotive qualification	AEC Q-100, grade 1
Chip Identifier	18 bit
Ambient temperature	-40 to +140°C
ESD protection	±2kV
Propagation delay (in locked state)	Max 22µs
Transition noise (rms; 1 sigma)	0.24°
Integral Nonlinearity (INL), centered magnet	+/-2°

Table 10. Parameter and Features List

Parameter	AS5134
Multiturn Counter	8-bit (+127/-128 turns). Optional: >8-bit (tbd) Automatically updated during active mode at every 360°/0°-transition in each rotating direction. The multiturn counter can be accessed over the serial interface and is reset with a power-on-reset. It will be frozen at the last valid state in low power mode.
Low power mode	Non-operational. Last status is frozen in Low power mode to allow low power consumption and fast startup from low power mode to operating mode. Serial interface is active in low power mode to allow wakeup over the serial interface. PWM, incremental and BLDC outputs are invalid in low power mode, they remain at their last valid state. Current consumption in low power mode: typ. 30µA
PWM output	2µs / step. 360° angle range in all modes. Minimum pos. pulse width (@0°) = 16µs (8 LSB; tbd) Minimum neg. pulse width (@359°) = 16µs (8 LSB; tbd) Pulse width @0° = 16µs, Pause = 736µs Pulse width @1° = 18µs, Pause = 734µs Pulse width @2° = 20µs, Pause = 732µs Pulse width @359° = 736µs, Pause = 16µs In case of an error (LOCK = Low), the pulse width is 8 µs (4 LSB), pause = 744µs for all angles.
Interface hardware	Incremental ABI interface: 3 pins BLDC UWV interface: 3 pins Absolute interface: 2 or 3 pins All outputs are available at the same time on separate pins
Maximum speed; no missing codes	30,000 rpm
Alignment tolerance	+/- 0.25 mm (reference to package center)
Normal operating Current consumption	Typ 14mA; max 22mA
Power-Up time	≤1.3 ms from cold start (no AGC), ≤4.1ms from cold start (AGC locked) <0.5ms from low power mode
Serial Interface read options	360-step Angle (9-bit), 6-bit AGC, 8-bit Multiturn, ADC Lock, (tbd)
Zero Position Programming	in OTP
Serial interface program options	Incremental mode(quad ABI, step/dir) BLDC pole pairs (1,2,3,4,5,6) Zero Position Hall sensor sensitivity
Serial interface write options (temporary write; will be lost with POR)	Incremental mode(quad ABI, step/dir) BLDC pole pairs (1,2,3,4,5,6) Zero Position Hall sensor sensitivity Multiturn counter reset to 00 Low power mode (on/off)

Table 10. Parameter and Features List

Parameter	AS5134	
IC package	SSOP-20	
magnetic range software indicator	Field strength (AGC) readable through digital interface	
Magnetic input field range [mT]	20 – 80 mT	
BLDC Outputs		
BLDC outputs	3 separate digital outputs: U,V,W	
BLDC pole pair options	Selectable for 1,2,3,4,5,6, pole pairs	
Hysteresis on BLDC outputs	Same as incremental output hysteresis	
Switching positions	Pole pairs	Switching position steps
	1	60°
	2	30°
	3	20°
	4	15°
	5	12°
6	10°	
Incremental Outputs		
Incremental modes	3 modes: Quad AB with Index (2x90 ppr), Step/direction (1x180 ppr) Fixed pulse width (360ppr, pulse width tbd)	
Step size	1°	
Incremental Hysteresis	2LSB (tbd)	
OTP Programming		
OTP programming technology	Zener Zapping	
OTP programming options	Zero position, Hall sensor sensitivity BLDC pole pairs (1,2,3,4,5,6) Incremental mode (quad AB, step/dir) Redundant Address Chip-Identifier	
OTP programming method	Over serial interface and static 8 - 8.5V Programming voltage at Pin PROG	
OTP programming verification	Digital and Analog	

9 Package Drawings and Markings

The device is available in a 20pin SSOP package.

Figure 18. 20-pin SSOP Package Drawings

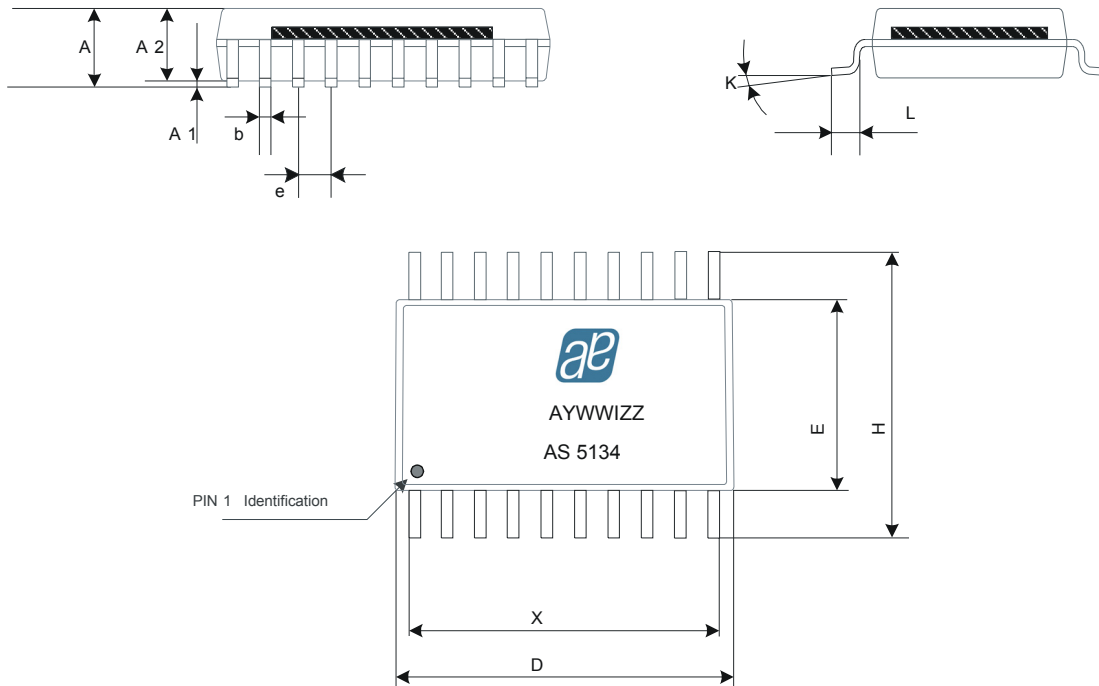

Table 11. 20-pin SSOP Package Dimensions

Symbol	mm			inch		
	Min	Typ	Max	Min	Typ	Max
A	1.73	1.86	1.99	0.068	0.073	0.078
A1	0.05	0.13	0.21	0.002	0.005	0.008
A2	1.68	1.73	1.78	0.066	0.068	0.070
b	0.25	-	0.38	0.010	-	0.015
D	7.07	7.20	7.33	0.278	0.284	0.289
E	5.20	5.30	5.38	0.205	0.209	0.212
e	0.65 BSC			0.0256 BSC		
H	7.65	7.80	7.90	0.301	0.307	0.311
K	0°	4°	8°	0°	4°	8°
L	0.63	0.75	0.95	0.025	0.030	0.037
X	-	$(10-1)*e + b$	-	-	$(10-1)e + b$	-

Recommended PCB Footprint

Figure 19. PCB Footprint

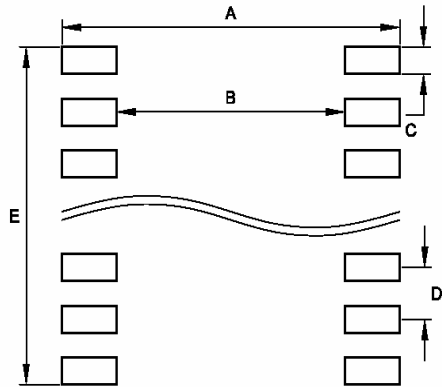

Table 12. Recommended Footprint Data

Symbol	mm	inch
A	9.02	0.355
B	6.16	0.242
C	0.46	0.018
D	0.65	0.025
E	6.31	0.248

10 Ordering Information

The devices are available as the standard products shown in [Table 13](#).

Table 13. Ordering Information

Model	Description	Delivery Form	Package
AS5134ASST	min. order quantity 2000pcs	Tape&Reel	SSOP20

Copyrights

Copyright © 1997-2008, austriamicrosystems AG, Schloss Premstaetten, 8141 Unterpremstaetten, Austria-Europe. Trademarks Registered ®. All rights reserved. The material herein may not be reproduced, adapted, merged, translated, stored, or used without the prior written consent of the copyright owner.

All products and companies mentioned are trademarks or registered trademarks of their respective companies.

Disclaimer

Devices sold by austriamicrosystems AG are covered by the warranty and patent indemnification provisions appearing in its Term of Sale. austriamicrosystems AG makes no warranty, express, statutory, implied, or by description regarding the information set forth herein or regarding the freedom of the described devices from patent infringement. austriamicrosystems AG reserves the right to change specifications and prices at any time and without notice. Therefore, prior to designing this product into a system, it is necessary to check with austriamicrosystems AG for current information. This product is intended for use in normal commercial applications. Applications requiring extended temperature range, unusual environmental requirements, or high reliability applications, such as military, medical life-support or life-sustaining equipment are specifically not recommended without additional processing by austriamicrosystems AG for each application. For shipments of less than 100 parts the manufacturing flow might show deviations from the standard production flow, such as test flow or test location.

The information furnished here by austriamicrosystems AG is believed to be correct and accurate. However, austriamicrosystems AG shall not be liable to recipient or any third party for any damages, including but not limited to personal injury, property damage, loss of profits, loss of use, interruption of business or indirect, special, incidental or consequential damages, of any kind, in connection with or arising out of the furnishing, performance or use of the technical data herein. No obligation or liability to recipient or any third party shall arise or flow out of austriamicrosystems AG rendering of technical or other services.



Contact Information

Headquarters

austriamicrosystems AG
A-8141 Schloss Premstaetten, Austria

Tel: +43 (0) 3136 500 0
Fax: +43 (0) 3136 525 01

For Sales Offices, Distributors and Representatives, please visit:

<http://www.austriamicrosystems.com/contact>