

FEATURES

- High Performance Accelerometer**
- $\pm 70g$, $\pm 250g$ And $\pm 500g$ Wideband Ranges Available**
- 22kHz Resonant Frequency Structure**
- High Linearity (0.2% of Full-scale)**
- Low-Noise ($4 \text{ mg}/\sqrt{\text{Hz}}$)**
- Sensitive Axis in the Plane of the Chip**
- Frequency Response Down To DC**
- Full Differential Signal Processing**
- High Resistance to EMI/RFI**
- Complete Electromechanical Self-test**
- Output Ratiometric to Supply**
- Velocity Preservation During Acceleration Input Overload**
- Low-Power Consumption (2.5mA typ)**
- 5mm LCC Hermetic Ceramic Package**

APPLICATIONS

- Vibration Monitoring**
- Shock Detection**
- Sports Diagnostic Equipment**
- Medical Instrumentation**
- Industrial Monitoring**

GENERAL DESCRIPTION

The ADXL001 is a major advance over previous generations of accelerometers - providing high performance and wide bandwidth. This part is ideal for industrial, medical, and military applications where wide bandwidth, small size, low power, and robust performance are essential.

Utilizing our proprietary 5th Generation iMEMs process enables the ADXL001 to provide the desired dynamic range that extends from $\pm 70g$ to $\pm 500g$ in combination with 22kHz of bandwidth. The accelerometer output channel passes through a wide bandwidth differential to single ended converter, which allows access to the full mechanical performance of the sensor.

The part can operate on voltage supplies from 3.3V to 5V.

The ADXL001 also has a Self-Test (ST) pin that can be asserted to verify the full electromechanical signal chain for the accelerometer channel.

FUNCTIONAL BLOCK DIAGRAM

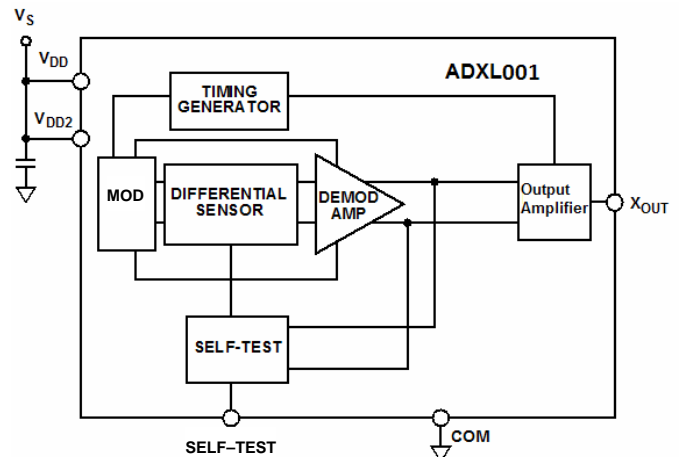

Figure 1. Functional Block Diagram

The ADXL001 is available in industry standard 8 pin LCC and is rated to work over the extended industrial temperature range (-40 to $+125^{\circ}\text{C}$).

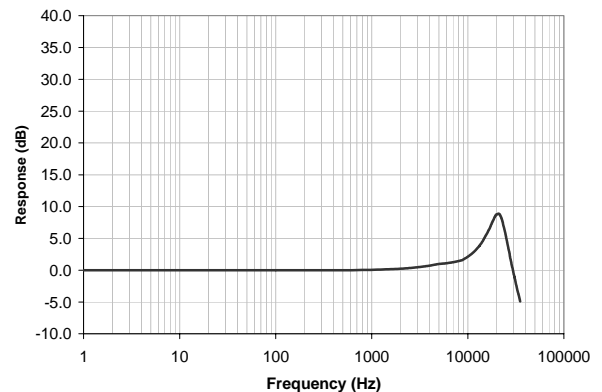

Figure 2. Sensor Frequency Response

This information applies to an ongoing development. Its characteristics and specifications are subject to change without notice. Analog Devices assumes no obligation regarding future manufacturing unless otherwise agreed to in writing. Patents pending.

Rev. PrA

Information furnished by Analog Devices is believed to be accurate and reliable. However, no responsibility is assumed by Analog Devices for its use, nor for any infringements of patents or other rights of third parties that may result from its use. Specifications subject to change without notice. No license is granted by implication or otherwise under any patent or patent rights of Analog Devices. Trademarks and registered trademarks are the property of their respective owners.

TABLE OF CONTENTS

Features	1	Applications.....	8
Applications.....	1	Application Circuit.....	8
GENERAL DESCRIPTION	1	Self-Test	8
Functional Block Diagram	1	Acceleration Sensitive Axis	8
Revision History	2	Operating Voltages Other Than 5V.....	8
Specifications.....	3	Layout, Grounding, and Bypassing Considerations	9
Absolute Maximum Ratings.....	5	Clock Frequency Supply Response	9
ESD Caution.....	5	Power Supply Decoupling	9
Pin Configuration and Function Descriptions.....	6	Electromagnetic Interference	9
Theory of Operation	7	Outline Dimensions	10
Design Principles.....	7	Ordering Guide.....	10
Mechanical Sensor.....	7		

REVISION HISTORY

4/08— Preliminary Technical Data Rev A

SPECIFICATIONS

Table 1. ADXL001 Specifications

 (@ T_A = -40°C to +125°C, V_S = 3.3V ± 5% DC, Acceleration = 0g; unless otherwise noted)

	Conditions	70g			250g			500g			Units
		Min	Typ	Max	Min	Typ	Max	Min	Typ	Max	
SENSOR											
Nonlinearity			0.2	2		0.2	2		0.2	2	%
Alignment error	Die in package		1			1			1		degree
Package resonance			130			130			130		kHz
Cross-axis sensitivity	Includes pkg. Alignment		2%			2%			2%		%
Resonant frequency			22			22			22		kHz
Quality factor			2.5			2.5			2.5		
SENSITIVITY											
	Ratiometric(1)			1			1			1	%
Full scale range	I _{out} ≤ ±100μA	-70		70	-250		250	-500		500	g
Sensitivity	V _S =3.3V, 100Hz		16.0			4.30			2.15		mV/g
Sensitivity	V _S =5V, 100Hz		24.2			6.5			3.26		mV/g
OFFSET											
	Ratiometric(1)										
Zero-g output	V _S =3.3V	1.35	1.65	1.95	TBD	1.65	TBD	TBD	1.65	TBD	V
Zero-g output	V _{out} -V _S /2	-90.9		90.9							mV/V
Noise											
Noise	10Hz-400Hz		100			100			100		mg rms
Noise density	10Hz-400Hz		4			4			4		mg/rt Hz
Frequency Response											
-3dB frequency			22			22			22		kHz
-3dB frequency drift			2			2			2		%
Self Test											
Delta V	V _S =3.3V		400			TBD			TBD		mV
Delta V (cubic vs. V _S)			10			TBD			TBD		mV/V ³
Logic input high	V _S =3.3V	2.1			2.1			2.1			V
Logic input low	V _S =3.3V			0.66			0.66			0.66	V
Input resistance	To Ground	30	50		30	50		30	50		kΩ
Output Amplifier											
Output swing	I _{out} = ±100μA	0.2		V _S -0.2	0.2		V _S -0.2	0.2		V _S -0.2	V
Capacitive load		1000			1000			1000			pF
PSRR/CFSR	DC-1MHz		0.5			0.5			0.5		V/V
Power Supply (V _S)											
Functional Range		3.135		6	3.135		6	3.135		6	V
I _{supply}			2.5	5		2.5	5		2.5	5	mA
Turn-on time			TBD			TBD			TBD		ms

This information applies to an ongoing development. Its characteristics and specifications are subject to change without notice. Analog Devices assumes no obligation regarding future manufacturing unless otherwise agreed to in writing. Patents pending.

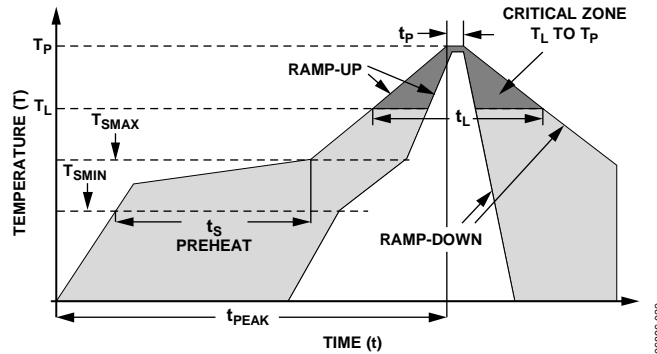

Figure 3. Recommended Soldering Profile

Table 2. Recommended Soldering Profile

Profile Feature	Sn63/Pb37	Pb-Free
Average Ramp Rate (T_L to T_P)	3°C/s maximum	3°C/s maximum
Preheat		
Minimum Temperature (T_{SMIN})	100°C	150°C
Maximum Temperature (T_{SMAX})	150°C	200°C
Time (T_{SMIN} to T_{SMAX}), t_s	60 sec to 120 sec	60 sec to 150 sec
T_{SMAX} to T_L		
Ramp-Up Rate	3°C/s	3°C/s
Time Maintained Above Liquidous (t_L)		
Liquidous Temperature (T_L)	183°C	217°C
Time (t_L)	60 sec to 150 sec	60 sec to 150 sec
Peak Temperature (T_P)	240°C + 0°C/-5°C	260°C + 0°C/-5°C
Time Within 5°C of Actual Peak Temperature (t_p)	10 sec to 30 sec	20 sec to 40 sec
Ramp-Down Rate	6°C/s maximum	6°C/s maximum
Time 25°C to Peak Temperature (t_{PEAK})	6 minute maximum	8 minute maximum

This information applies to an ongoing development. Its characteristics and specifications are subject to change without notice. Analog Devices assumes no obligation regarding future manufacturing unless otherwise agreed to in writing. Patents pending.

ABSOLUTE MAXIMUM RATINGS

Table 3. Absolute Maximum Ratings

Parameter*	Rating
Acceleration (Any Axis, Unpowered and Powered)	4000 <i>g</i>
Supply Voltage <i>V</i> _s	-0.3 to 7.0V
Output Short Circuit Duration (<i>V</i> _{out} , to Ground)	Indefinite
Storage Temperature	-65°C to 150°C
Soldering Temperature Range (Soldering 10 sec)	245°C
Operating Temperature Range	-55°C to 125°C

*Stresses above those listed under Absolute Maximum Ratings may cause permanent damage to the device. This is a stress rating only; functional operation of the device at these or any other conditions above those indicated in the operational section of this specification is not implied. Exposure to absolute maximum rating conditions for extended periods may affect device reliability.

Drops onto hard surfaces can cause shocks of greater than 4000 *g* and can exceed the absolute maximum rating of the device. Exercise care during handling to avoid damage.

ESD CAUTION



ESD (electrostatic discharge) sensitive device. Charged devices and circuit boards can discharge without detection. Although this product features patented or proprietary protection circuitry, damage may occur on devices subjected to high energy ESD. Therefore, proper ESD precautions should be taken to avoid performance degradation or loss of functionality.

PIN CONFIGURATION AND FUNCTION DESCRIPTIONS

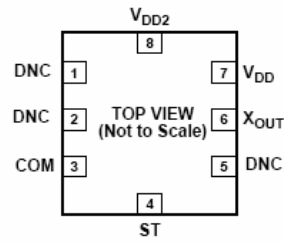

DNC = DO NOT CONNECT

Figure 4. Pin Configuration

Table 4. Pin Function Descriptions

Pin No.	Mnemonic	Description
1	DNC	Do Not Connect
2	DNC	Do Not Connect
3	COM	Common
4	ST	Self Test Control (Logic Input)
5	DNC	Do Not Connect
6	X _{OUT}	X Axis Acceleration Output
7	V _{DD}	3.135 V to 6 V (Should Be Connected Physically To V _{DD2})
8	V _{DD2}	3.135 V to 6 V (Should Be Connected Physically To V _{DD})

THEORY OF OPERATION

DESIGN PRINCIPLES

The ADXL001 accelerometer provides a fully differential sensor structure and circuit path for excellent resistance to EMI/RFI interference.

This latest generation SOIMEMS device takes advantage of mechanically coupled but electrically isolated differential sensing cells. This improves sensor performance and size as a single proof mass generates the fully differential signal. The sensor signal conditioning also uses electrical feedback with zero-force feedback for improved accuracy and stability. This force-feedback cancels out the electrostatic forces contributed by the sensor circuitry.

Figure 5 is a simplified view of one of the differential sensor cell blocks. Each sensor block includes several differential capacitor unit cells. Each cell is composed of fixed plates attached to the device layer and movable plates attached to the sensor frame. Displacement of the sensor frame changes the differential capacitance. On-chip circuitry measures the capacitive change.

MECHANICAL SENSOR

The ADXL001 is built using the Analog Devices, Inc., SOIMEMS sensor process. The sensor device is micromachined in-plane in the SOI device layer. Trench isolation is used to electrically isolate, but mechanically couple, the differential sensing elements. Single-crystal silicon springs suspend the structure over the handle wafer and provide resistance against acceleration forces.

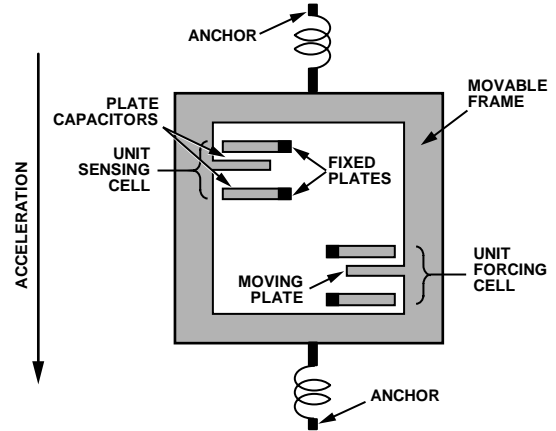

Figure 5. Simplified View of Sensor Under Acceleration

06898E-019

APPLICATIONS

APPLICATION CIRCUIT

Figure 6 shows the standard application circuit for the ADXL001. Note that V_{DD} and V_{DD2} should always be connected. The output is shown connected to a 1000 pF output capacitor for improved EMI performance and can be connected directly to the ADC input of a microcontroller. See the ADC specifications for proper antialiasing filtering, based on the user's sample rate.

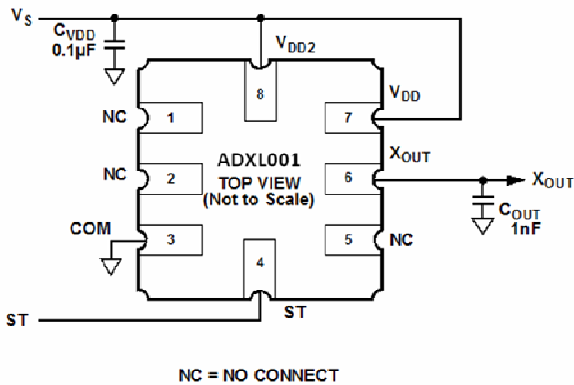

Figure 6. Application Circuit

SELF-TEST

The fixed fingers in the forcing cells are normally kept at the same potential as that of the movable frame. When the user activates the digital self-test input, the ADXL001 changes the voltage on the fixed fingers in these forcing cells on one side of the moving plate. This potential creates an attractive electrostatic force, causing the sensor to move towards those fixed fingers. The entire signal channel is active, so the sensor displacement causes a change in X_{out} . The ADXL001 self-test function verifies proper operation of the sensor, interface electronics, and accelerometer channel electronics.

The ST pin should never be exposed to voltages greater than $V_S + 0.3$ V. If this cannot be guaranteed due to the system design (for instance, if there are multiple supply voltages), then a low V_F clamping diode between ST and V_S is recommended.

ACCELERATION SENSITIVE AXIS

The ADXL001 is an X-Axis acceleration and vibration-sensing device. It produces a positive-going output voltage for vibration toward its Pin 8 marking.

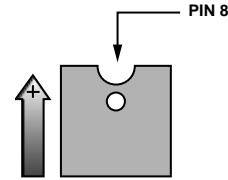

Figure 7. X_{out} Increases with Acceleration in the +X-Axis Direction

OPERATING VOLTAGES OTHER THAN 5V

The ADXL001 is specified at $V_S = 3.3$ V and $V_S = 5$ V. Note that some performance parameters change as the voltage is varied.

In particular, the X_{out} output exhibits ratiometric offset and sensitivity with supply. The output sensitivity (or scale factor) scales proportionally to the supply voltage. At $V_S = 3.3$ V, output sensitivity is typically 16 mV/g. At $V_S = 5$ V, sensitivity is nominally 24.2 mV/g. X_{out} zero g bias is nominally equal to $V_S/2$ at all supply voltages.

Self-test response in g is roughly proportional to the square of the supply voltage. However, when one factors ratiometricity of sensitivity in with supply voltage, the self-test response in voltage is roughly proportional to the cube of the supply voltage. For example, the self-test response for the ADXL001-70 at $V_S = 5$ V is approximately 1.4 V. At $V_S = 3.3$ V, the response is approximately 400 mV.

LAYOUT, GROUNDING, AND BYPASSING CONSIDERATIONS

CLOCK FREQUENCY SUPPLY RESPONSE

In any clocked system, power supply noise near the clock frequency may have consequences at other frequencies. An internal clock typically controls the sensor excitation and the signal demodulator for micromachined accelerometers.

If the power supply contains high frequency spikes, they may be demodulated and interpreted as acceleration signals. A signal appears at the difference between the noise frequency and the demodulator frequency. If the power supply noise is 100 Hz away from the demodulator clock, there will be an output term at 100 Hz. If the power supply clock is at exactly the same frequency as the accelerometer clock, the term will appear as an offset. If the difference frequency is outside the signal bandwidth, the output filter attenuates it. However, both the power supply clock and the accelerometer clock may vary with time or temperature, which can cause the interference signal to appear in the output filter bandwidth.

ADXL001 addresses this issue in two ways. First, the high clock frequency, 125 kHz for the output stage, eases the task of choosing a power supply clock frequency such that the difference between it and the accelerometer clock remains well outside the filter bandwidth. Second, ADXL001 has a fully differential signal path, including a pair of electrically isolated, mechanically coupled sensors. The differential sensors eliminate most of the power supply noise before it reaches the demodulator. Good high frequency supply bypassing, such as a ceramic capacitor close to the supply pins, also minimizes the amount of interference.

Clock frequency supply response (CFSR) is the ratio of the response at the output to the noise on the power supply near the accelerometer clock frequency or its harmonics. A CFSR of 0.5 means that the signal at the output is half the amplitude of the supply noise. This is analogous to power supply rejection ratio (PSRR), except that the stimulus and the response are at different frequencies.

POWER SUPPLY DECOUPLING

For most applications, a single 0.1 μF capacitor, C_{DC} , adequately decouples the accelerometer from noise on the power supply. However, in some cases, particularly where noise is present at the 1 MHz internal clock frequency (or any harmonic thereof), noise on the supply can cause interference on the ADXL001 output. If additional decoupling is needed, a 50 Ω (or smaller) resistor or ferrite bead can be inserted in the supply line. Additionally, a larger bulk bypass capacitor (in the 1 μF to 4.7 μF range) can be added in parallel to C_{DC} .

ELECTROMAGNETIC INTERFERENCE

The ADXL001 can be used in areas and applications with high amounts of EMI or with components susceptible to EMI emissions. The fully differential circuitry of the ADXL001 is designed to be robust to such interference. For improved EMI performance, especially in automotive applications, a 1000 pF output capacitor is recommended on the X_{OUT} output.

OUTLINE DIMENSIONS

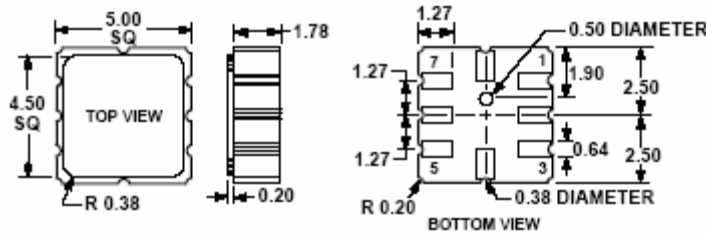

8-Terminal Ceramic Leadless Chip Carrier [LCC]
(E-8)

Dimensions shown in millimeters

Figure 8. Package Dimensions

ORDERING GUIDE

Table 5. Ordering Guide

Model	Branding	Package	Gee Range	Temperature Range
ADXL001-70	TBD	LCC-8	± 70g	-40°C to 125°C
ADXL001-250	TBD	LCC-8	± 250g	-40°C to 125°C
ADXL001-500	TBD	LCC-8	± 500g	-40°C to 125°C